

To our customers,

---

## Old Company Name in Catalogs and Other Documents

---

On April 1<sup>st</sup>, 2010, NEC Electronics Corporation merged with Renesas Technology Corporation, and Renesas Electronics Corporation took over all the business of both companies. Therefore, although the old company name remains in this document, it is a valid Renesas Electronics document. We appreciate your understanding.

Renesas Electronics website: <http://www.renesas.com>

April 1<sup>st</sup>, 2010  
Renesas Electronics Corporation

Issued by: Renesas Electronics Corporation (<http://www.renesas.com>)

Send any inquiries to <http://www.renesas.com/inquiry>.

## Notice

1. All information included in this document is current as of the date this document is issued. Such information, however, is subject to change without any prior notice. Before purchasing or using any Renesas Electronics products listed herein, please confirm the latest product information with a Renesas Electronics sales office. Also, please pay regular and careful attention to additional and different information to be disclosed by Renesas Electronics such as that disclosed through our website.
2. Renesas Electronics does not assume any liability for infringement of patents, copyrights, or other intellectual property rights of third parties by or arising from the use of Renesas Electronics products or technical information described in this document. No license, express, implied or otherwise, is granted hereby under any patents, copyrights or other intellectual property rights of Renesas Electronics or others.
3. You should not alter, modify, copy, or otherwise misappropriate any Renesas Electronics product, whether in whole or in part.
4. Descriptions of circuits, software and other related information in this document are provided only to illustrate the operation of semiconductor products and application examples. You are fully responsible for the incorporation of these circuits, software, and information in the design of your equipment. Renesas Electronics assumes no responsibility for any losses incurred by you or third parties arising from the use of these circuits, software, or information.
5. When exporting the products or technology described in this document, you should comply with the applicable export control laws and regulations and follow the procedures required by such laws and regulations. You should not use Renesas Electronics products or the technology described in this document for any purpose relating to military applications or use by the military, including but not limited to the development of weapons of mass destruction. Renesas Electronics products and technology may not be used for or incorporated into any products or systems whose manufacture, use, or sale is prohibited under any applicable domestic or foreign laws or regulations.
6. Renesas Electronics has used reasonable care in preparing the information included in this document, but Renesas Electronics does not warrant that such information is error free. Renesas Electronics assumes no liability whatsoever for any damages incurred by you resulting from errors in or omissions from the information included herein.
7. Renesas Electronics products are classified according to the following three quality grades: “Standard”, “High Quality”, and “Specific”. The recommended applications for each Renesas Electronics product depends on the product’s quality grade, as indicated below. You must check the quality grade of each Renesas Electronics product before using it in a particular application. You may not use any Renesas Electronics product for any application categorized as “Specific” without the prior written consent of Renesas Electronics. Further, you may not use any Renesas Electronics product for any application for which it is not intended without the prior written consent of Renesas Electronics. Renesas Electronics shall not be in any way liable for any damages or losses incurred by you or third parties arising from the use of any Renesas Electronics product for an application categorized as “Specific” or for which the product is not intended where you have failed to obtain the prior written consent of Renesas Electronics. The quality grade of each Renesas Electronics product is “Standard” unless otherwise expressly specified in a Renesas Electronics data sheets or data books, etc.
  - “Standard”: Computers; office equipment; communications equipment; test and measurement equipment; audio and visual equipment; home electronic appliances; machine tools; personal electronic equipment; and industrial robots.
  - “High Quality”: Transportation equipment (automobiles, trains, ships, etc.); traffic control systems; anti-disaster systems; anti-crime systems; safety equipment; and medical equipment not specifically designed for life support.
  - “Specific”: Aircraft; aerospace equipment; submersible repeaters; nuclear reactor control systems; medical equipment or systems for life support (e.g. artificial life support devices or systems), surgical implantations, or healthcare intervention (e.g. excision, etc.), and any other applications or purposes that pose a direct threat to human life.
8. You should use the Renesas Electronics products described in this document within the range specified by Renesas Electronics, especially with respect to the maximum rating, operating supply voltage range, movement power voltage range, heat radiation characteristics, installation and other product characteristics. Renesas Electronics shall have no liability for malfunctions or damages arising out of the use of Renesas Electronics products beyond such specified ranges.
9. Although Renesas Electronics endeavors to improve the quality and reliability of its products, semiconductor products have specific characteristics such as the occurrence of failure at a certain rate and malfunctions under certain use conditions. Further, Renesas Electronics products are not subject to radiation resistance design. Please be sure to implement safety measures to guard them against the possibility of physical injury, and injury or damage caused by fire in the event of the failure of a Renesas Electronics product, such as safety design for hardware and software including but not limited to redundancy, fire control and malfunction prevention, appropriate treatment for aging degradation or any other appropriate measures. Because the evaluation of microcomputer software alone is very difficult, please evaluate the safety of the final products or system manufactured by you.
10. Please contact a Renesas Electronics sales office for details as to environmental matters such as the environmental compatibility of each Renesas Electronics product. Please use Renesas Electronics products in compliance with all applicable laws and regulations that regulate the inclusion or use of controlled substances, including without limitation, the EU RoHS Directive. Renesas Electronics assumes no liability for damages or losses occurring as a result of your noncompliance with applicable laws and regulations.
11. This document may not be reproduced or duplicated, in any form, in whole or in part, without prior written consent of Renesas Electronics.
12. Please contact a Renesas Electronics sales office if you have any questions regarding the information contained in this document or Renesas Electronics products, or if you have any other inquiries.

(Note 1) “Renesas Electronics” as used in this document means Renesas Electronics Corporation and also includes its majority-owned subsidiaries.

(Note 2) “Renesas Electronics product(s)” means any product developed or manufactured by or for Renesas Electronics.

## User's Manual

# V850E/SJ3-H, V850E/SK3-H

## 32-bit Single-Chip Microcontrollers

### Hardware

---

#### V850E/SJ3-H:

<b><math>\mu</math>PD70F3474</b>	<b><math>\mu</math>PD70F3475</b>	<b><math>\mu</math>PD70F3476</b>
<b><math>\mu</math>PD70F3477</b>	<b><math>\mu</math>PD70F3478</b>	<b><math>\mu</math>PD70F3479</b>
<b><math>\mu</math>PD70F3931</b>	<b><math>\mu</math>PD70F3932</b>	<b><math>\mu</math>PD70F3933</b>
<b><math>\mu</math>PD70F3934</b>	<b><math>\mu</math>PD70F3935</b>	<b><math>\mu</math>PD70F3936</b>
<b><math>\mu</math>PD70F3937</b>	<b><math>\mu</math>PD70F3938</b>	<b><math>\mu</math>PD70F3939</b>

#### V850E/SK3-H:

<b><math>\mu</math>PD70F3480</b>	<b><math>\mu</math>PD70F3481</b>	<b><math>\mu</math>PD70F3482</b>
<b><math>\mu</math>PD70F3486</b>	<b><math>\mu</math>PD70F3487</b>	<b><math>\mu</math>PD70F3488</b>
<b><math>\mu</math>PD70F3925</b>	<b><math>\mu</math>PD70F3926</b>	<b><math>\mu</math>PD70F3927</b>

[MEMO]

## NOTES FOR CMOS DEVICES

- (1) **VOLTAGE APPLICATION WAVEFORM AT INPUT PIN:** Waveform distortion due to input noise or a reflected wave may cause malfunction. If the input of the CMOS device stays in the area between  $V_{IL}$  (MAX) and  $V_{IH}$  (MIN) due to noise, etc., the device may malfunction. Take care to prevent chattering noise from entering the device when the input level is fixed, and also in the transition period when the input level passes through the area between  $V_{IL}$  (MAX) and  $V_{IH}$  (MIN).
- (2) **HANDLING OF UNUSED INPUT PINS:** Unconnected CMOS device inputs can be cause of malfunction. If an input pin is unconnected, it is possible that an internal input level may be generated due to noise, etc., causing malfunction. CMOS devices behave differently than Bipolar or NMOS devices. Input levels of CMOS devices must be fixed high or low by using pull-up or pull-down circuitry. Each unused pin should be connected to VDD or GND via a resistor if there is a possibility that it will be an output pin. All handling related to unused pins must be judged separately for each device and according to related specifications governing the device.
- (3) **PRECAUTION AGAINST ESD:** A strong electric field, when exposed to a MOS device, can cause destruction of the gate oxide and ultimately degrade the device operation. Steps must be taken to stop generation of static electricity as much as possible, and quickly dissipate it when it has occurred. Environmental control must be adequate. When it is dry, a humidifier should be used. It is recommended to avoid using insulators that easily build up static electricity. Semiconductor devices must be stored and transported in an anti-static container, static shielding bag or conductive material. All test and measurement tools including work benches and floors should be grounded. The operator should be grounded using a wrist strap. Semiconductor devices must not be touched with bare hands. Similar precautions need to be taken for PW boards with mounted semiconductor devices.
- (4) **STATUS BEFORE INITIALIZATION:** Power-on does not necessarily define the initial status of a MOS device. Immediately after the power source is turned ON, devices with reset functions have not yet been initialized. Hence, power-on does not guarantee output pin levels, I/O settings or contents of registers. A device is not initialized until the reset signal is received. A reset operation must be executed immediately after power-on for devices with reset functions.
- (5) **POWER ON/OFF SEQUENCE:** In the case of a device that uses different power supplies for the internal operation and external interface, as a rule, switch on the external power supply after switching on the internal power supply. When switching the power supply off, as a rule, switch off the external power supply and then the internal power supply. Use of the reverse power on/off sequences may result in the application of an overvoltage to the internal elements of the device, causing malfunction and degradation of internal elements due to the passage of an abnormal current. The correct power on/off sequence must be judged separately for each device and according to related specifications governing the device.
- (6) **INPUT OF SIGNAL DURING POWER OFF STATE :** Do not input signals or an I/O pull-up power supply while the device is not powered. The current injection that results from input of such a signal or I/O pull-up power supply may cause malfunction and the abnormal current that passes in the device at this time may cause degradation of internal elements. Input of signals during the power off state must be judged separately for each device and according to related specifications governing the device.

Caution: This product uses SuperFlash® technology licensed from Silicon Storage Technology, Inc.

**IECUBE is a registered trademark of NEC Electronics Corporation in Japan and Germany.**

**MINICUBE is a registered trademark of NEC Electronics Corporation in Japan and Germany or a trademark in the United States of America.**

**EEPROM, IEBus, and Inter Equipment Bus are trademarks of NEC Electronics Corporation.**

**Windows and Windows NT are either registered trademarks or trademarks of Microsoft Corporation in the United States and/or other countries.**

**PC/AT is a trademark of International Business Machines Corporation.**

**SPARCstation is a trademark of SPARC International, Inc.**

**Solaris and SunOS are trademarks of Sun Microsystems, Inc.**

**SuperFlash is a registered trademark of Silicon Storage Technology, Inc. in several countries including the United States and Japan.**

- The information in this document is current as of September, 2009. The information is subject to change without notice. For actual design-in, refer to the latest publications of NEC Electronics data sheets or data books, etc., for the most up-to-date specifications of NEC Electronics products. Not all products and/or types are available in every country. Please check with an NEC Electronics sales representative for availability and additional information.
  - No part of this document may be copied or reproduced in any form or by any means without the prior written consent of NEC Electronics. NEC Electronics assumes no responsibility for any errors that may appear in this document.
  - NEC Electronics does not assume any liability for infringement of patents, copyrights or other intellectual property rights of third parties by or arising from the use of NEC Electronics products listed in this document or any other liability arising from the use of such products. No license, express, implied or otherwise, is granted under any patents, copyrights or other intellectual property rights of NEC Electronics or others.
  - Descriptions of circuits, software and other related information in this document are provided for illustrative purposes in semiconductor product operation and application examples. The incorporation of these circuits, software and information in the design of a customer's equipment shall be done under the full responsibility of the customer. NEC Electronics assumes no responsibility for any losses incurred by customers or third parties arising from the use of these circuits, software and information.
  - While NEC Electronics endeavors to enhance the quality, reliability and safety of NEC Electronics products, customers agree and acknowledge that the possibility of defects thereof cannot be eliminated entirely. To minimize risks of damage to property or injury (including death) to persons arising from defects in NEC Electronics products, customers must incorporate sufficient safety measures in their design, such as redundancy, fire-containment and anti-failure features.
  - NEC Electronics products are classified into the following three quality grades: "Standard", "Special" and "Specific". The "Specific" quality grade applies only to NEC Electronics products developed based on a customer-designated "quality assurance program" for a specific application. The recommended applications of an NEC Electronics product depend on its quality grade, as indicated below. Customers must check the quality grade of each NEC Electronics product before using it in a particular application.
    - "Standard": Computers, office equipment, communications equipment, test and measurement equipment, audio and visual equipment, home electronic appliances, machine tools, personal electronic equipment and industrial robots.
    - "Special": Transportation equipment (automobiles, trains, ships, etc.), traffic control systems, anti-disaster systems, anti-crime systems, safety equipment and medical equipment (not specifically designed for life support).
    - "Specific": Aircraft, aerospace equipment, submersible repeaters, nuclear reactor control systems, life support systems and medical equipment for life support, etc.
- The quality grade of NEC Electronics products is "Standard" unless otherwise expressly specified in NEC Electronics data sheets or data books, etc. If customers wish to use NEC Electronics products in applications not intended by NEC Electronics, they must contact an NEC Electronics sales representative in advance to determine NEC Electronics' willingness to support a given application.
- (Note 1) "NEC Electronics" as used in this statement means NEC Electronics Corporation and also includes its majority-owned subsidiaries.
- (Note 2) "NEC Electronics products" means any product developed or manufactured by or for NEC Electronics (as defined above).

(M8E0909)

## PREFACE

**Readers** This manual is intended for users who wish to understand the functions of the V850E/SJ3-H and V850E/SK3-H and design application systems using the V850E/SJ3-H and V850E/SK3-H.

**Purpose** This manual is intended to give users an understanding of the hardware functions of the V850E/SJ3-H and V850E/SK3-H shown in the **Organization** below.

**Organization** The manual of these products is divided into two volumes: Hardware (this volume) and Architecture (**V850E1 Architecture User's Manual**).

Hardware
----------

- Pin functions
- CPU function
- On-chip peripheral functions
- Flash memory programming
- Electrical specifications

Architecture
--------------

- Data types
- Register set
- Instruction format and instruction set
- Interrupts and exceptions
- Pipeline operation

**How to Read This Manual** It is assumed that the readers of this manual have general knowledge in the fields of electrical engineering, logic circuits, and microcontrollers.

**Caution** The application examples in this manual apply to “standard” quality grade products for general electronic systems. When using an example in this manual for an application that requires a “special” quality grade product, thoroughly evaluate the component and circuit to be actually used to see if they satisfy the special quality grade.

To understand the overall functions of the V850E/SJ3-H and V850E/SK3-H  
→Read this manual according to the **CONTENTS**.

To find the details of a register where the name is known  
→Use **APPENDIX B REGISTER INDEX**.

Register format

→The name of the bit whose number is in angle brackets (<>) in the figure of the register format of each register is defined as a reserved word in the device file.

To understand the details of an instruction function

→Refer to the **V850E1 Architecture User's Manual** available separately.

To know the electrical specifications of the V850E/SJ3-H and V850E/SK3-H

→See **CHAPTER 35 ELECTRICAL SPECIFICATIONS**.

The “yyy bit of the xxx register” is described as the “xxx.yyy bit” in this manual. Note with caution that if “xxx.yyy” is described as is in a program, however, the compiler/assembler cannot recognize it correctly.

The mark <R> shows major revised points. The revised points can be easily searched by copying an "<R>" in the PDF file and specifying it in the "Find what." field.

## Conventions

Data significance:	Higher digits on the left and lower digits on the right
Active low representation:	$\overline{xxx}$ (overscore over pin or signal name)
Memory map address:	Higher addresses on the top and lower addresses on the bottom
<b>Note:</b>	Footnote for item marked with <b>Note</b> in the text
<b>Caution:</b>	Information requiring particular attention
<b>Remark:</b>	Supplementary information
Numeric representation:	Binary ... xxxx or xxxxB Decimal ... xxxx Hexadecimal ... xxxxH
Prefix indicating power of 2 (address space, memory capacity):	K (kilo): $2^{10} = 1,024$ M (mega): $2^{20} = 1,024^2$ G (giga): $2^{30} = 1,024^3$



## Related Documents

The related documents indicated in this publication may include preliminary versions. However, preliminary versions are not marked as such.

### Documents related to V850E/SJ3-H, V850E/SK3-H

Document Name	Document No.
V850E1 Architecture User's Manual	U14559E
V850E/SJ3-H, V850E/SK3-H Hardware User's Manual	This manual

### Documents related to development tools

Document Name	Document No.	
IE-V850E1-CD-NW (PCMCIA Card Type On-Chip Debug Emulator)	U16647E	
QB-V850ESX3H (In-Circuit Emulator)	To be prepared	
QB-V850MINI (On-Chip Debug Emulator)	U17638E	
QB-MINI2 (On-Chip Debug Emulator with Programming Function)	U18371E	
QB-Programmer Programming GUI	Operation	U18527E
CA850 Ver. 3.20 C Compiler Package	Operation	U18512E
	C Language	U18513E
	Assembly Language	U18514E
	Link Directives	U18515E
PM+ Ver. 6.30 Project Manager		U18416E
ID850QB Ver. 3.40 Integrated Debugger	Operation	U18604E
TW850 Ver. 2.00 Performance Analysis Tuning Tool		U17241E
RX850 Ver. 3.20 Real-Time OS	Basics	U13430E
	Installation	U17419E
	Technical	U13431E
	Task Debugger	U17420E
RX850 Pro Ver. 3.21 Real-Time OS	Basics	U18165E
	In-Structure	U18164E
	Task Debugger	U17422E
AZ850 Ver. 3.30 System Performance Analyzer		U17423E
PG-FP5 Flash Memory Programmer		U18865E

# CONTENTS

<b>CHAPTER 1 INTRODUCTION .....</b>	<b>22</b>
<b>1.1 General .....</b>	<b>22</b>
<b>1.2 Features .....</b>	<b>25</b>
<b>1.3 Application Fields .....</b>	<b>27</b>
<b>1.4 Ordering Information .....</b>	<b>28</b>
1.4.1 V850E/SJ3-H.....	28
1.4.2 V850E/SK3-H .....	29
<b>1.5 Pin Configuration (Top View).....</b>	<b>29</b>
1.5.1 V850E/SJ3-H.....	29
1.5.2 V850E/SK3-H .....	32
<b>1.6 Function Block Configuration.....</b>	<b>35</b>
1.6.1 Internal block diagram .....	35
1.6.2 Internal units .....	39
<b>CHAPTER 2 PIN FUNCTIONS .....</b>	<b>43</b>
<b>2.1 List of Pin Functions.....</b>	<b>43</b>
<b>2.2 Port Sharing of Alternate Functions .....</b>	<b>60</b>
<b>2.3 Pin States .....</b>	<b>65</b>
<b>2.4 Pin I/O Circuit Types, I/O Buffer Power Supplies and Connection of Unused Pins.....</b>	<b>66</b>
<b>2.5 Cautions .....</b>	<b>73</b>
<b>CHAPTER 3 CPU FUNCTION.....</b>	<b>74</b>
<b>3.1 Features .....</b>	<b>74</b>
<b>3.2 CPU Register Set.....</b>	<b>75</b>
3.2.1 Program register set .....	76
3.2.2 System register set.....	77
<b>3.3 Operation Modes .....</b>	<b>84</b>
3.3.1 Specifying operation mode .....	84
<b>3.4 Address Space .....</b>	<b>85</b>
3.4.1 CPU address space.....	85
3.4.2 Wraparound of CPU address space .....	86
3.4.3 Memory map.....	87
3.4.4 Areas .....	91
3.4.5 Recommended use of address space .....	100
3.4.6 Peripheral I/O registers.....	104
3.4.7 Programmable peripheral I/O registers.....	123
3.4.8 Special registers .....	124
3.4.9 Cautions .....	128
<b>CHAPTER 4 PORT FUNCTIONS .....</b>	<b>133</b>
<b>4.1 Features .....</b>	<b>133</b>
4.1.1 V850E/SJ3-H.....	133
4.1.2 V850E/SK3-H .....	133
<b>4.2 Basic Port Configuration.....</b>	<b>134</b>

4.2.1	V850E/SJ3-H.....	134
4.2.2	V850E/SK3-H.....	135
<b>4.3</b>	<b>Port Configuration .....</b>	<b>136</b>
4.3.1	Port 0.....	141
4.3.2	Port 1.....	145
4.3.3	Port 2 (V850E/SK3-H only) .....	146
4.3.4	Port 3.....	148
4.3.5	Port 4.....	157
4.3.6	Port 5.....	161
4.3.7	Port 6.....	167
4.3.8	Port 7.....	175
4.3.9	Port 8.....	177
4.3.10	Port 9.....	182
4.3.11	Port 13 (V850E/SK3-H only).....	190
4.3.12	Port 14 (V850E/SK3-H only).....	191
4.3.13	Port 15 (V850E/SK3-H only).....	192
4.3.14	Port CD .....	194
4.3.15	Port CM.....	196
4.3.16	Port CS.....	198
4.3.17	Port CT.....	200
4.3.18	Port DH .....	202
4.3.19	Port DL.....	204
<b>4.4</b>	<b>Block Diagrams.....</b>	<b>207</b>
<b>4.5</b>	<b>Port Register Settings When Alternate Function Is Used .....</b>	<b>270</b>
<b>4.6</b>	<b>Cautions.....</b>	<b>284</b>
4.6.1	Cautions on setting port pins.....	284
4.6.2	Cautions on bit manipulation instruction for port n register (Pn) .....	287
4.6.3	Cautions on on-chip debug pins .....	288
4.6.4	Cautions on P05/INTP2/ $\overline{\text{DRST}}$ pin .....	288
4.6.5	Cautions on P53 pin when power is turned on .....	288
4.6.6	Hysteresis characteristics.....	288
4.6.7	Cautions on separate bus mode.....	289
4.6.8	Cautions on reading port n registers (Pn: n = 3 to 5, 8) (V850E/SJ3-H only) .....	289
4.6.9	Cautions on setting port n mode control registers (PMcn: n = 3 to 5, 8) .....	289
<b>CHAPTER 5</b>	<b>BUS CONTROL FUNCTION.....</b>	<b>290</b>
<b>5.1</b>	<b>Features .....</b>	<b>290</b>
<b>5.2</b>	<b>Bus Control Pins.....</b>	<b>291</b>
5.2.1	Pin status when internal ROM, internal RAM, on-chip peripheral I/O, or expanded internal RAM is accessed.....	292
5.2.2	Pin status in each operation mode .....	292
<b>5.3</b>	<b>Memory Block Function .....</b>	<b>293</b>
5.3.1	Chip select control function .....	296
<b>5.4</b>	<b>External Bus Interface Mode Control Function .....</b>	<b>301</b>
<b>5.5</b>	<b>Bus Access.....</b>	<b>302</b>
5.5.1	Number of clocks for access .....	302
5.5.2	Bus size setting function.....	303
5.5.3	Access by bus size.....	304

<b>5.6</b>	<b>Wait Function.....</b>	<b>311</b>
5.6.1	Programmable wait function .....	311
5.6.2	External wait function .....	314
5.6.3	Relationship between programmable wait and external wait .....	315
5.6.4	Programmable address wait function.....	316
<b>5.7</b>	<b>Idle State Insertion Function.....</b>	<b>318</b>
<b>5.8</b>	<b>Bus Hold Function .....</b>	<b>319</b>
5.8.1	Functional outline .....	319
5.8.2	Bus hold procedure .....	320
5.8.3	Operation in power save mode.....	320
<b>5.9</b>	<b>Bus Priority .....</b>	<b>321</b>
<b>5.10</b>	<b>Bus Timing.....</b>	<b>322</b>
<b>CHAPTER 6 CLOCK GENERATION FUNCTION .....</b>		<b>328</b>
<b>6.1</b>	<b>Overview .....</b>	<b>328</b>
<b>6.2</b>	<b>Clock Mode .....</b>	<b>329</b>
6.2.1	Clock mode 1.....	332
6.2.2	Clock mode 2.....	335
6.2.3	Clock mode 3.....	338
6.2.4	Clock mode 4.....	341
6.2.5	Clock mode setting .....	344
<b>6.3</b>	<b>Registers .....</b>	<b>345</b>
<b>6.4</b>	<b>Operation .....</b>	<b>355</b>
6.4.1	Operation of each clock .....	355
6.4.2	Clock output function .....	356
6.4.3	Procedure for setting clock generation function for using clock mode 1 .....	357
6.4.4	Procedure for setting clock generation function for using clock modes 2, 3, and 4.....	360
<b>CHAPTER 7 16-BIT TIMER/EVENT COUNTER P (TMP) .....</b>		<b>364</b>
<b>7.1</b>	<b>Overview .....</b>	<b>364</b>
7.1.1	TMP0 to TMP6 .....	364
7.1.2	TMP7 and TMP8 .....	364
<b>7.2</b>	<b>Functions .....</b>	<b>365</b>
7.2.1	TMP0 to TMP6 .....	365
7.2.2	TMP7 and TMP8 .....	365
<b>7.3</b>	<b>Configuration.....</b>	<b>366</b>
7.3.1	TMP0 to TMP6 .....	366
7.3.2	TMP7 and TMP8 .....	369
<b>7.4</b>	<b>Registers .....</b>	<b>372</b>
<b>7.5</b>	<b>Timer Output Operations.....</b>	<b>394</b>
<b>7.6</b>	<b>Operation .....</b>	<b>395</b>
7.6.1	Interval timer mode (TPnMD2 to TPnMD0 bits = 000).....	404
7.6.2	External event count mode (TPnMD2 to TPnMD0 bits = 001).....	416
7.6.3	External trigger pulse output mode (TPnMD2 to TPnMD0 bits = 010).....	425
7.6.4	One-shot pulse output mode (TPnMD2 to TPnMD0 bits = 011) .....	437
7.6.5	PWM output mode (TPnMD2 to TPnMD0 bits = 100).....	444
7.6.6	Free-running timer mode (TPnMD2 to TPnMD0 bits = 101) .....	453
7.6.7	Pulse width measurement mode (TPnMD2 to TPnMD0 bits = 110) .....	471

7.6.8	Encoder count function (only for TMP7 and TMP8).....	477
7.6.9	Encoder compare mode (TPmMD3 to TPmMD0 bits = 1000) .....	491
<b>7.7</b>	<b>Selector Function.....</b>	<b>499</b>
<b>7.8</b>	<b>Cautions.....</b>	<b>501</b>
<b>CHAPTER 8 16-BIT TIMER/EVENT COUNTER Q (TMQ) .....</b>		<b>502</b>
<b>8.1</b>	<b>Overview .....</b>	<b>502</b>
<b>8.2</b>	<b>Functions .....</b>	<b>502</b>
<b>8.3</b>	<b>Configuration .....</b>	<b>503</b>
<b>8.4</b>	<b>Registers.....</b>	<b>506</b>
<b>8.5</b>	<b>Timer Output Operations .....</b>	<b>521</b>
<b>8.6</b>	<b>Operation .....</b>	<b>522</b>
8.6.1	Interval timer mode (TQ0MD2 to TQ0MD0 bits = 000).....	530
8.6.2	External event count mode (TQ0MD2 to TQ0MD0 bits = 001) .....	541
8.6.3	External trigger pulse output mode (TQ0MD2 to TQ0MD0 bits = 010).....	551
8.6.4	One-shot pulse output mode (TQ0MD2 to TQ0MD0 bits = 011) .....	564
8.6.5	PWM output mode (TQ0MD2 to TQ0MD0 bits = 100).....	573
8.6.6	Free-running timer mode (TQ0MD2 to TQ0MD0 bits = 101) .....	584
8.6.7	Pulse width measurement mode (TQ0MD2 to TQ0MD0 bits = 110) .....	605
<b>8.7</b>	<b>Selector Function.....</b>	<b>610</b>
<b>8.8</b>	<b>Cautions.....</b>	<b>611</b>
<b>CHAPTER 9 16-BIT INTERVAL TIMER M (TMM).....</b>		<b>612</b>
<b>9.1</b>	<b>Overview .....</b>	<b>612</b>
<b>9.2</b>	<b>Configuration .....</b>	<b>613</b>
<b>9.3</b>	<b>Register.....</b>	<b>615</b>
<b>9.4</b>	<b>Operation .....</b>	<b>616</b>
9.4.1	Interval timer mode.....	616
9.4.2	Cautions .....	620
<b>CHAPTER 10 WATCH FUNCTIONS .....</b>		<b>621</b>
<b>10.1</b>	<b>Overview .....</b>	<b>621</b>
<b>10.2</b>	<b>Configuration .....</b>	<b>622</b>
<b>10.3</b>	<b>Prescaler 3.....</b>	<b>623</b>
10.3.1	Function .....	623
10.3.2	Configuration.....	623
10.3.3	Registers .....	624
<b>10.4</b>	<b>Watch Timer Functions .....</b>	<b>626</b>
10.4.1	Functions.....	626
10.4.2	Configuration .....	626
10.4.3	Control Registers.....	628
10.4.4	Operation .....	630
<b>10.5</b>	<b>Real-time Counter (RTC).....</b>	<b>632</b>
10.5.1	Function .....	632
10.5.2	Configuration.....	633
10.5.3	Registers .....	636
10.5.4	Operation .....	649

<b>CHAPTER 11 FUNCTIONS OF WATCHDOG TIMER 2</b> .....	<b>661</b>
11.1 Functions .....	661
11.2 Configuration.....	662
11.3 Registers .....	663
11.4 Operation .....	667
<b>CHAPTER 12 REAL-TIME OUTPUT FUNCTION (RTO)</b> .....	<b>668</b>
12.1 Function .....	668
12.2 Configuration.....	669
12.3 Registers .....	671
12.4 Operation .....	673
12.5 Usage.....	674
12.6 Cautions .....	674
<b>CHAPTER 13 A/D CONVERTER</b> .....	<b>675</b>
13.1 Overview .....	675
13.2 Functions .....	675
13.3 Configuration.....	676
13.4 Registers .....	679
13.5 Operation .....	690
13.5.1 Basic operation.....	690
13.5.2 Conversion operation timing .....	691
13.5.3 Trigger mode .....	692
13.5.4 Operation mode.....	694
13.5.5 Power-fail compare mode.....	698
13.6 Cautions .....	703
13.7 How to Read A/D Converter Characteristics Table .....	708
<b>CHAPTER 14 D/A CONVERTER</b> .....	<b>712</b>
14.1 Functions .....	712
14.2 Configuration.....	712
14.3 Registers .....	713
14.4 Operation .....	715
14.4.1 Operation in normal mode .....	715
14.4.2 Operation in real-time output mode .....	715
14.4.3 Cautions .....	716
<b>CHAPTER 15 ASYNCHRONOUS SERIAL INTERFACE A (UARTA)</b> .....	<b>717</b>
15.1 Port Settings of UARTA0 to UARTA5.....	717
15.1.1 For V850E/SJ3-H .....	717
15.1.2 For V850E/SK3-H.....	719
15.2 Features .....	721
15.3 Configuration.....	722
15.4 Registers .....	725
15.5 Interrupt Request Signals .....	732
15.6 Operation .....	733
15.6.1 Data format.....	733

15.6.2	SBF transmission/reception format .....	735
15.6.3	SBF transmission .....	737
15.6.4	SBF reception.....	738
15.6.5	UART transmission .....	739
15.6.6	Continuous transmission procedure.....	740
15.6.7	UART reception.....	742
15.6.8	Reception errors.....	743
15.6.9	Parity types and operations.....	745
15.6.10	Receive data noise filter .....	746
<b>15.7</b>	<b>Dedicated Baud Rate Generator.....</b>	<b>747</b>
<b>15.8</b>	<b>Cautions.....</b>	<b>757</b>
 <b>CHAPTER 16 ASYNCHRONOUS SERIAL INTERFACE B (UARTB).....</b>		<b>759</b>
<b>16.1</b>	<b>Features .....</b>	<b>759</b>
<b>16.2</b>	<b>Configuration .....</b>	<b>760</b>
<b>16.3</b>	<b>Control Registers .....</b>	<b>764</b>
<b>16.4</b>	<b>Interrupt Request Signals .....</b>	<b>784</b>
<b>16.5</b>	<b>Control Modes .....</b>	<b>787</b>
<b>16.6</b>	<b>Operation .....</b>	<b>791</b>
16.6.1	Data format .....	791
16.6.2	Transmit operation .....	792
16.6.3	Continuous transmission operation .....	795
16.6.4	Receive operation .....	796
16.6.5	Reception error.....	799
16.6.6	Parity types and corresponding operation .....	800
16.6.7	Receive data noise filter .....	801
<b>16.7</b>	<b>Dedicated Baud Rate Generator (BRG).....</b>	<b>803</b>
<b>16.8</b>	<b>Control Flow .....</b>	<b>809</b>
<b>16.9</b>	<b>Cautions.....</b>	<b>818</b>
 <b>CHAPTER 17 3-WIRE VARIABLE-LENGTH SERIAL I/O B (CSIB).....</b>		<b>820</b>
<b>17.1</b>	<b>Port Settings of CSIB0 to CSIB5 .....</b>	<b>820</b>
17.1.1	For V850E/SJ3-H .....	820
17.1.2	For V850E/SK3-H.....	822
<b>17.2</b>	<b>Features .....</b>	<b>824</b>
<b>17.3</b>	<b>Configuration .....</b>	<b>825</b>
<b>17.4</b>	<b>Registers.....</b>	<b>828</b>
<b>17.5</b>	<b>Interrupt Request Signals .....</b>	<b>836</b>
<b>17.6</b>	<b>Operation .....</b>	<b>837</b>
17.6.1	Single transfer mode (master mode, transmission mode) .....	837
17.6.2	Single transfer mode (master mode, reception mode) .....	839
17.6.3	Single transfer mode (master mode, transmission/reception mode) .....	842
17.6.4	Single transfer mode (slave mode, transmission mode).....	845
17.6.5	Single transfer mode (slave mode, reception mode) .....	847
17.6.6	Single transfer mode (slave mode, transmission/reception mode) .....	849
17.6.7	Continuous transfer mode (master mode, transmission mode) .....	851
17.6.8	Continuous transfer mode (master mode, reception mode) .....	854
17.6.9	Continuous transfer mode (master mode, transmission/reception mode) .....	857

17.6.10	Continuous transfer mode (slave mode, transmission mode)	861
17.6.11	Continuous transfer mode (slave mode, reception mode)	863
17.6.12	Continuous transfer mode (slave mode, transmission/reception mode)	866
17.6.13	Reception error	870
17.6.14	Clock timing	871
<b>17.7</b>	<b>Output Pins</b>	<b>873</b>
<b>17.8</b>	<b>Baud Rate Generator</b>	<b>874</b>
17.8.1	Baud rate generation	876
<b>17.9</b>	<b>Cautions</b>	<b>877</b>
<b>CHAPTER 18</b>	<b>3-WIRE VARIABLE-LENGTH SERIAL I/O E (CSIE)</b>	<b>878</b>
<b>18.1</b>	<b>Port Setting of CSIE0 and CSIE1</b>	<b>878</b>
18.1.1	V850E/SJ3-H (other than $\mu$ PD70F3931, 70F3932, 70F3933)	878
18.1.2	V850E/SK3-H	879
<b>18.2</b>	<b>Features</b>	<b>880</b>
<b>18.3</b>	<b>Configuration</b>	<b>881</b>
<b>18.4</b>	<b>Control Registers</b>	<b>885</b>
<b>18.5</b>	<b>Baud Rate Generator n (BRGn)</b>	<b>895</b>
<b>18.6</b>	<b>Operation</b>	<b>897</b>
<b>18.7</b>	<b>How to Use</b>	<b>918</b>
<b>18.8</b>	<b>Cautions</b>	<b>925</b>
<b>CHAPTER 19</b>	<b>I<sup>2</sup>C BUS</b>	<b>926</b>
<b>19.1</b>	<b>Port Settings of I<sup>2</sup>C00 to I<sup>2</sup>C05</b>	<b>927</b>
19.1.1	For V850E/SJ3-H	927
19.1.2	For V850E/SK3-H	929
<b>19.2</b>	<b>Features</b>	<b>931</b>
<b>19.3</b>	<b>Configuration</b>	<b>932</b>
<b>19.4</b>	<b>Registers</b>	<b>936</b>
<b>19.5</b>	<b>I<sup>2</sup>C Bus Mode Functions</b>	<b>954</b>
19.5.1	Pin configuration	954
<b>19.6</b>	<b>I<sup>2</sup>C Bus Definitions and Control Methods</b>	<b>955</b>
19.6.1	Start condition	956
19.6.2	Addresses	957
19.6.3	Transfer direction specification	958
19.6.4	ACK	959
19.6.5	Stop condition	960
19.6.6	Wait state	961
19.6.7	Wait state cancellation method	963
<b>19.7</b>	<b>I<sup>2</sup>C Interrupt Request Signals (INTIICn)</b>	<b>964</b>
19.7.1	Master device operation	965
19.7.2	Slave device operation (when receiving slave address (address match))	968
19.7.3	Slave device operation (when receiving extension code)	972
19.7.4	Operation without communication	976
19.7.5	Arbitration loss operation (operation as slave after arbitration loss)	977
19.7.6	Operation when arbitration loss occurs (no communication after arbitration loss)	979
<b>19.8</b>	<b>Interrupt Request Signal (INTIICn) Generation Timing and Wait Control</b>	<b>986</b>
<b>19.9</b>	<b>Address Match Detection Method</b>	<b>987</b>



<b>19.10 Error Detection</b> .....	<b>987</b>
<b>19.11 Extension Code</b> .....	<b>988</b>
<b>19.12 Arbitration</b> .....	<b>989</b>
<b>19.13 Wakeup Function</b> .....	<b>990</b>
<b>19.14 Communication Reservation</b> .....	<b>991</b>
19.14.1 When communication reservation function is enabled (IICFn.IICRSVn bit = 0) .....	991
19.14.2 When communication reservation function is disabled (IICFn.IICRSVn bit = 1) .....	995
<b>19.15 Cautions</b> .....	<b>996</b>
<b>19.16 Communication Operations</b> .....	<b>998</b>
19.16.1 Master operation in single master system .....	999
19.16.2 Master operation in multimaster system .....	1000
19.16.3 Slave operation .....	1003
<b>19.17 Timing of Data Communication</b> .....	<b>1007</b>
<b>CHAPTER 20 IEBus CONTROLLER</b> .....	<b>1014</b>
<b>20.1 Functions</b> .....	<b>1014</b>
20.1.1 Communication protocol of IEBus .....	1014
20.1.2 Determination of bus mastership (arbitration) .....	1015
20.1.3 Communication mode .....	1015
20.1.4 Communication address .....	1015
20.1.5 Broadcast communication .....	1016
20.1.6 Transfer format of IEBus .....	1016
20.1.7 Transfer data .....	1026
20.1.8 Bit format .....	1028
<b>20.2 Configuration</b> .....	<b>1029</b>
<b>20.3 Registers</b> .....	<b>1031</b>
<b>20.4 Interrupt Operations of IEBus Controller</b> .....	<b>1061</b>
20.4.1 Interrupt control block .....	1061
20.4.2 Example of identifying interrupt .....	1063
20.4.3 Interrupt source list .....	1066
20.4.4 Communication error source processing list .....	1067
<b>20.5 Interrupt Request Signal Generation Timing and Main CPU Processing</b> .....	<b>1069</b>
20.5.1 Master transmission .....	1069
20.5.2 Master reception .....	1071
20.5.3 Slave transmission .....	1073
20.5.4 Slave reception .....	1075
20.5.5 Interval of occurrence of interrupt request signal for IEBus control .....	1077
<b>20.6 Caution</b> .....	<b>1081</b>
<b>CHAPTER 21 CAN CONTROLLER</b> .....	<b>1082</b>
<b>21.1 Overview</b> .....	<b>1082</b>
21.1.1 Features .....	1082
21.1.2 Overview of functions .....	1083
21.1.3 Configuration .....	1084
<b>21.2 CAN Protocol</b> .....	<b>1085</b>
21.2.1 Frame format .....	1085
21.2.2 Frame types .....	1086
21.2.3 Data frame and remote frame .....	1086

21.2.4	Error frame .....	1094
21.2.5	Overload frame.....	1095
<b>21.3</b>	<b>Functions .....</b>	<b>1096</b>
21.3.1	Determining bus priority.....	1096
21.3.2	Bit stuffing.....	1096
21.3.3	Multi masters .....	1096
21.3.4	Multi cast .....	1096
21.3.5	CAN sleep mode/CAN stop mode function.....	1097
21.3.6	Error control function .....	1097
21.3.7	Baud rate control function.....	1104
<b>21.4</b>	<b>Connection with Target System .....</b>	<b>1108</b>
<b>21.5</b>	<b>Internal Registers of CAN Controller .....</b>	<b>1109</b>
21.5.1	CAN controller configuration.....	1109
21.5.2	Register access type .....	1110
21.5.3	Register bit configuration .....	1144
<b>21.6</b>	<b>Registers .....</b>	<b>1148</b>
<b>21.7</b>	<b>Bit Set/Clear Function.....</b>	<b>1184</b>
<b>21.8</b>	<b>CAN Controller Initialization .....</b>	<b>1186</b>
21.8.1	Initialization of CAN module.....	1186
21.8.2	Initialization of message buffer .....	1186
21.8.3	Redefinition of message buffer .....	1186
21.8.4	Transition from initialization mode to operation mode.....	1187
21.8.5	Resetting error counter CnERC of CAN module.....	1188
<b>21.9</b>	<b>Message Reception.....</b>	<b>1189</b>
21.9.1	Message reception .....	1189
21.9.2	Reading reception data.....	1190
21.9.3	Receive history list function .....	1191
21.9.4	Mask function .....	1193
21.9.5	Multi buffer receive block function .....	1195
21.9.6	Remote frame reception .....	1196
<b>21.10</b>	<b>Message Transmission.....</b>	<b>1197</b>
21.10.1	Message transmission.....	1197
21.10.2	Transmit history list function .....	1199
21.10.3	Automatic block transmission (ABT).....	1201
21.10.4	Transmission abort process.....	1203
21.10.5	Remote frame transmission.....	1204
<b>21.11</b>	<b>Power Saving Modes .....</b>	<b>1205</b>
21.11.1	CAN sleep mode .....	1205
21.11.2	CAN stop mode .....	1207
21.11.3	Example of using power saving modes .....	1208
<b>21.12</b>	<b>Interrupt Function .....</b>	<b>1209</b>
<b>21.13</b>	<b>Diagnosis Functions and Special Operational Modes .....</b>	<b>1210</b>
21.13.1	Receive-only mode.....	1210
21.13.2	Single-shot mode.....	1211
21.13.3	Self-test mode .....	1212
21.13.4	Transmission/reception operation in each operation mode .....	1213
<b>21.14</b>	<b>Time Stamp Function.....</b>	<b>1214</b>
21.14.1	Time stamp function .....	1214

<b>21.15 Baud Rate Settings</b> .....	<b>1216</b>
21.15.1 Bit rate setting conditions .....	1216
21.15.2 Representative examples of baud rate settings .....	1220
<b>21.16 Operation of CAN Controller</b> .....	<b>1224</b>
<b>CHAPTER 22 DMA FUNCTION (DMA CONTROLLER)</b> .....	<b>1250</b>
<b>22.1 Features</b> .....	<b>1250</b>
<b>22.2 Configuration</b> .....	<b>1251</b>
<b>22.3 Registers</b> .....	<b>1252</b>
<b>22.4 Transfer Targets</b> .....	<b>1261</b>
<b>22.5 Transfer Modes</b> .....	<b>1261</b>
<b>22.6 Transfer Types</b> .....	<b>1262</b>
<b>22.7 DMA Channel Priorities</b> .....	<b>1263</b>
<b>22.8 Time Related to DMA Transfer</b> .....	<b>1263</b>
<b>22.9 DMA Transfer Start Factors</b> .....	<b>1264</b>
<b>22.10 DMA Abort Factors</b> .....	<b>1265</b>
<b>22.11 End of DMA Transfer</b> .....	<b>1265</b>
<b>22.12 Operation Timing</b> .....	<b>1265</b>
<b>22.13 Cautions</b> .....	<b>1270</b>
<b>CHAPTER 23 CRC FUNCTION</b> .....	<b>1273</b>
<b>23.1 Functions</b> .....	<b>1273</b>
<b>23.2 Configuration</b> .....	<b>1273</b>
<b>23.3 Registers</b> .....	<b>1274</b>
<b>23.4 Operation</b> .....	<b>1275</b>
<b>23.5 Usage Method</b> .....	<b>1276</b>
<b>CHAPTER 24 INTERRUPT/EXCEPTION PROCESSING FUNCTION</b> .....	<b>1278</b>
<b>24.1 Features</b> .....	<b>1278</b>
<b>24.2 Non-Maskable Interrupts</b> .....	<b>1284</b>
24.2.1 Operation .....	1286
24.2.2 Restore .....	1287
24.2.3 NP flag .....	1288
<b>24.3 Maskable Interrupts</b> .....	<b>1289</b>
24.3.1 Operation .....	1289
24.3.2 Restore .....	1291
24.3.3 Priorities of maskable interrupts .....	1292
24.3.4 Interrupt control register (xxICn) .....	1296
24.3.5 Interrupt mask registers 0 to 6, 7L (IMR0 to IMR6, IMR7L) .....	1300
24.3.6 In-service priority register (ISPR) .....	1303
24.3.7 ID flag .....	1304
24.3.8 Watchdog timer mode register 2 (WDTM2) .....	1304
<b>24.4 Software Exception</b> .....	<b>1305</b>
24.4.1 Operation .....	1305
24.4.2 Restore .....	1306
24.4.3 EP flag .....	1307
<b>24.5 Exception Trap</b> .....	<b>1308</b>
24.5.1 Illegal opcode definition .....	1308

24.5.2	Debug trap.....	1310
<b>24.6</b>	<b>External Interrupt Request Input Pins (NMI and INTP0 to INTP9).....</b>	<b>1312</b>
24.6.1	Noise elimination .....	1312
24.6.2	Edge detection.....	1312
<b>24.7</b>	<b>Interrupt Acknowledge Time of CPU.....</b>	<b>1323</b>
<b>24.8</b>	<b>Periods in Which Interrupts Are Not Acknowledged by CPU.....</b>	<b>1325</b>
<b>24.9</b>	<b>Cautions .....</b>	<b>1325</b>
<b>CHAPTER 25 KEY INTERRUPT FUNCTION .....</b>		<b>1326</b>
<b>25.1</b>	<b>Function .....</b>	<b>1326</b>
<b>25.2</b>	<b>Register .....</b>	<b>1327</b>
<b>25.3</b>	<b>Cautions .....</b>	<b>1327</b>
<b>CHAPTER 26 STANDBY FUNCTION .....</b>		<b>1329</b>
<b>26.1</b>	<b>Overview .....</b>	<b>1329</b>
<b>26.2</b>	<b>Registers .....</b>	<b>1330</b>
<b>26.3</b>	<b>HALT Mode .....</b>	<b>1334</b>
26.3.1	Setting and operation status .....	1334
26.3.2	Releasing HALT mode.....	1334
<b>26.4</b>	<b>IDLE1 Mode.....</b>	<b>1336</b>
26.4.1	Setting and operation status .....	1336
26.4.2	Releasing IDLE1 mode.....	1336
<b>26.5</b>	<b>IDLE2 Mode.....</b>	<b>1339</b>
26.5.1	Setting and operation status .....	1339
26.5.2	Releasing IDLE2 mode.....	1340
26.5.3	Securing setup time when releasing IDLE2 mode .....	1342
<b>26.6</b>	<b>STOP Mode .....</b>	<b>1343</b>
26.6.1	Setting and operation status .....	1343
26.6.2	Releasing STOP mode.....	1343
26.6.3	Securing oscillation stabilization time when releasing STOP mode.....	1346
<b>26.7</b>	<b>Subclock Operation Mode.....</b>	<b>1347</b>
26.7.1	Setting and operation status .....	1347
26.7.2	Releasing subclock operation mode .....	1347
<b>26.8</b>	<b>Sub-IDLE Mode.....</b>	<b>1350</b>
26.8.1	Setting and operation status .....	1350
26.8.2	Releasing sub-IDLE mode.....	1351
<b>26.9</b>	<b>Status Transition Diagram .....</b>	<b>1354</b>
<b>CHAPTER 27 RESET FUNCTIONS .....</b>		<b>1358</b>
<b>27.1</b>	<b>Overview .....</b>	<b>1358</b>
<b>27.2</b>	<b>Registers to Check Reset Source .....</b>	<b>1360</b>
<b>27.3</b>	<b>Operation .....</b>	<b>1361</b>
27.3.1	Reset operation via $\overline{\text{RESET}}$ pin .....	1361
27.3.2	Reset operation by watchdog timer 2 (WDT2RES) .....	1363
27.3.3	Reset operation by low-voltage detector (LVIREs) .....	1365
27.3.4	Reset operation by clock monitor (CLMRES) .....	1366
27.3.5	Operation after reset release .....	1368
27.3.6	Reset function operation flow .....	1369

<b>CHAPTER 28 CLOCK MONITOR</b> .....	<b>1370</b>
<b>28.1 Functions</b> .....	<b>1370</b>
<b>28.2 Configuration</b> .....	<b>1370</b>
<b>28.3 Register</b> .....	<b>1371</b>
<b>28.4 Operation</b> .....	<b>1372</b>
<b>CHAPTER 29 LOW-VOLTAGE DETECTOR</b> .....	<b>1375</b>
<b>29.1 Functions</b> .....	<b>1375</b>
<b>29.2 Configuration</b> .....	<b>1375</b>
<b>29.3 Registers</b> .....	<b>1376</b>
<b>29.4 Operation</b> .....	<b>1378</b>
29.4.1 To use for internal reset signal (LVIREs) .....	1378
29.4.2 To use for interrupt (INTLVI) .....	1379
<b>29.5 RAM Retention Voltage Detection Operation</b> .....	<b>1380</b>
<b>29.6 Emulation Function</b> .....	<b>1381</b>
<b>CHAPTER 30 REGULATOR</b> .....	<b>1382</b>
<b>30.1 Overview</b> .....	<b>1382</b>
<b>30.2 Operation</b> .....	<b>1383</b>
<b>CHAPTER 31 ROM CORRECTION FUNCTION</b> .....	<b>1384</b>
<b>31.1 Overview</b> .....	<b>1384</b>
<b>31.2 Registers</b> .....	<b>1385</b>
<b>31.3 ROM Correction Operation and Program Flow</b> .....	<b>1388</b>
<b>31.4 Cautions</b> .....	<b>1390</b>
<b>CHAPTER 32 FLASH MEMORY</b> .....	<b>1391</b>
<b>32.1 Features</b> .....	<b>1391</b>
<b>32.2 Memory Configuration</b> .....	<b>1392</b>
<b>32.3 Functional Outline</b> .....	<b>1394</b>
<b>32.4 Rewriting by Dedicated Flash Memory Programmer</b> .....	<b>1397</b>
32.4.1 Programming environment .....	1397
32.4.2 Communication mode .....	1398
32.4.3 Flash memory control .....	1406
32.4.4 Selection of communication mode .....	1407
32.4.5 Communication commands .....	1408
32.4.6 Pin connection .....	1409
<b>32.5 Rewriting by Self Programming</b> .....	<b>1414</b>
32.5.1 Overview .....	1414
32.5.2 Features .....	1415
32.5.3 Standard self programming flow .....	1418
32.5.4 Flash functions .....	1419
32.5.5 Pin processing .....	1419
32.5.6 Internal resources used .....	1420
<b>CHAPTER 33 OPTION BYTE FUNCTION</b> .....	<b>1421</b>
<b>33.1 Option Byte (0000007AH)</b> .....	<b>1422</b>

	<b>33.2 Option Byte (000007BH)</b> .....	<b>1423</b>
	<b>CHAPTER 34 ON-CHIP DEBUG FUNCTION</b> .....	<b>1425</b>
	<b>34.1 Debugging with DCU</b> .....	<b>1426</b>
	34.1.1 Connection circuit example.....	1426
	34.1.2 Interface signals .....	1427
<R>	34.1.3 Maskable functions.....	1429
	34.1.4 Register .....	1429
	34.1.5 Operation.....	1431
	34.1.6 Cautions .....	1432
<R>	<b>34.2 Debugging Without Using DCU</b> .....	<b>1433</b>
	34.2.1 Circuit connection examples.....	1433
	34.2.2 Maskable functions.....	1435
	34.2.3 Securement of user resources.....	1436
	34.2.4 Cautions .....	1443
	<b>34.3 ROM Security Function</b> .....	<b>1444</b>
	34.3.1 Security ID.....	1444
	34.3.2 Setting .....	1445
	<b>CHAPTER 35 ELECTRICAL SPECIFICATIONS</b> .....	<b>1447</b>
	<b>35.1 Absolute Maximum Ratings</b> .....	<b>1447</b>
	<b>35.2 Capacitance</b> .....	<b>1449</b>
	<b>35.3 Operating Conditions</b> .....	<b>1449</b>
	<b>35.4 Oscillator Characteristics</b> .....	<b>1450</b>
	35.4.1 Main clock oscillator characteristics.....	1450
	35.4.2 Subclock oscillator characteristics .....	1453
	35.4.3 PLL characteristics .....	1454
	35.4.4 SSCG characteristics .....	1454
	35.4.5 Internal oscillator characteristics.....	1454
	<b>35.5 Regulator Characteristics</b> .....	<b>1455</b>
	<b>35.6 DC Characteristics</b> .....	<b>1456</b>
	35.6.1 I/O level .....	1456
	35.6.2 Supply current .....	1458
	<b>35.7 Data Retention Characteristics</b> .....	<b>1459</b>
	<b>35.8 AC Characteristics</b> .....	<b>1460</b>
	35.8.1 CLKOUT output timing .....	1461
	35.8.2 Bus timing.....	1462
	<b>35.9 Basic Operation</b> .....	<b>1475</b>
	<b>35.10 Flash Memory Programming Characteristics</b> .....	<b>1486</b>
	<b>CHAPTER 36 PACKAGE DRAWINGS</b> .....	<b>1488</b>
	<b>CHAPTER 37 RECOMMENDED SOLDERING CONDITIONS</b> .....	<b>1490</b>
	<b>APPENDIX A DEVELOPMENT TOOLS</b> .....	<b>1492</b>
	<b>A.1 Software Package</b> .....	<b>1497</b>
	<b>A.2 Language Processing Software</b> .....	<b>1497</b>

	<b>A.3</b>	<b>Control Software .....</b>	<b>1497</b>
	<b>A.4</b>	<b>Debugging Tools (Hardware).....</b>	<b>1498</b>
	A.4.1	When using IECUBE QB-V850ESX3H.....	1498
	A.4.2	When using on-chip debug emulator IE-V850E1-CD-NW .....	1501
<R>	A.4.3	When using MINICUBE QB-V850MINI.....	1502
	A.4.4	When using MINICUBE2 QB-MINI2 .....	1503
	<b>A.5</b>	<b>Debugging Tools (Software).....</b>	<b>1504</b>
	<b>A.6</b>	<b>Embedded Software .....</b>	<b>1505</b>
	<b>A.7</b>	<b>Flash Memory Writing Tools.....</b>	<b>1506</b>
	<b>APPENDIX B</b>	<b>REGISTER INDEX.....</b>	<b>1507</b>
	<b>APPENDIX C</b>	<b>INSTRUCTION SET LIST.....</b>	<b>1527</b>
	C.1	Conventions .....	1527
	C.2	Instruction Set (in Alphabetical Order).....	1530
	<b>APPENDIX D</b>	<b>LIST OF CAUTIONS.....</b>	<b>1537</b>
	<b>APPENDIX E</b>	<b>REVISION HISTORY .....</b>	<b>1592</b>
	E.1	Major Revisions in This Edition.....	1592
<R>	E.2	Revision History of Previous Editions.....	1596

## CHAPTER 1 INTRODUCTION

The V850E/SJ3-H and V850E/SK3-H are the products in the NEC Electronics V850 single-chip microcontrollers designed for real-time control applications.

### 1.1 General

The V850E/SJ3-H and V850E/SK3-H are 32-bit single-chip microcontrollers that include the V850E1 CPU core and peripheral functions such as ROM/RAM, a timer/counter, serial interfaces, an A/D converter, and a D/A converter. As for automotive LAN, the V850E/SJ3-H and V850E/SK3-H are provided with IEBus™ (Inter Equipment Bus™), and some of the models are also provided with CAN (Controller Area Network).

In addition to high real-time response characteristics and 1-clock-pitch basic instructions, the V850E/SJ3-H and V850E/SK3-H feature multiply instructions, saturated operation instructions, bit manipulation instructions, etc., realized by a hardware multiplier, as optimum instructions for digital servo control applications. Moreover, as a real-time control system, the V850E/SJ3-H and V850E/SK3-H enable extremely high cost performance for automotive-use multimedia equipment such as car audio systems.

Table 1-1 lists the products of the V850E/SJ3-H and V850E/SK3-H.

A model of the V850E/SJ3-H and V850E/SK3-H with reduced I/O, timer/counter, and serial interface functions, V850ES/SJ3, is also available. See **Table 1-2 List of V850ES/SJ3 Products**.



Table 1-1. V850E/SJ3-H and V850E/SK3-H Products (1/2)

(a) V850E/SJ3-H (144-pin plastic LQFP (20 × 20))

Function Part Number	ROM		RAM Size (+ Expanded Internal RAM Size)	Operating Frequency (MAX.)	i°C	Automotive LAN	Maskable Interrupts		Non- Maskable Interrupts		
	Type	Size					External	Internal			
μPD70F3474	Flash memory	1280 KB	60 KB (+ 32 KB)	48 MHz	On-chip	IEBus: 1 ch	10	94	2		
μPD70F3475								98			
μPD70F3476								102			
μPD70F3477								1536 KB		94	
μPD70F3478										98	
μPD70F3479										102	
<R> μPD70F3931		512 KB	60 KB (None)							88	
<R> μPD70F3932										92	
<R> μPD70F3933										96	
<R> μPD70F3934								768 KB		60 KB (+16 KB)	94
<R> μPD70F3935											98
<R> μPD70F3936											102
<R> μPD70F3937	1024 KB	94									
<R> μPD70F3938		98									
<R> μPD70F3939		102									

**Remark** Also read **Caution** and **Remark** on the next page.

Table 1-1. V850E/SJ3-H and V850E/SK3-H Products (2/2)

## (b) V850E/SK3-H (176-pin plastic LQFP (24 × 24))

Function Part Number	ROM		RAM Size (+ Expanded Internal RAM Size)	Operating Frequency (MAX.)	I <sup>2</sup> C	Automotive LAN	Maskable Interrupts		Non- Maskable Interrupts
	Type	Size					External	Internal	
$\mu$ PD70F3480	Flash memory	1536 KB	60 KB (+ 32 KB)	48 MHz	On-chip	IEBus: 1 ch	10	94	2
$\mu$ PD70F3481								98	
$\mu$ PD70F3482								102	
$\mu$ PD70F3486								94	
$\mu$ PD70F3487								98	
$\mu$ PD70F3488								102	
$\mu$ PD70F3925		1024 KB	60 KB (+ 16 KB)	48 MHz	On-chip	IEBus: 1 ch	10	94	
$\mu$ PD70F3926								98	
$\mu$ PD70F3927								102	

<R> **Caution** Note with caution that in addition to the contents of the above table, the  $\mu$ PD70F3931, 70F3932, and 70F3933 also differ from the other products in terms of the following functions.

Part Number	CSIE	I <sup>2</sup> C
$\mu$ PD70F3931, 70F3932, 70F3933	None	4 ch
Other than $\mu$ PD70F3931, 70F3932, and 70F3933	On-chip (2 ch)	6 ch

**Remark** The part numbers of the V850E/SJ3-H and V850E/SK3-H are shown as follows in this manual.

- CAN controller version  
 $\mu$ PD70F3475, 70F3476, 70F3478, 70F3479, 70F3481, 70F3482, 70F3487, 70F3488, 70F3926, 70F3927, 70F3932, 70F3933, 70F3935, 70F3936, 70F3938, and 70F3939
- CAN controller (2-channel) version  
 $\mu$ PD70F3476, 70F3479, 70F3482, 70F3488, 70F3927, 70F3933, 70F3936, and 70F3939
- Expanded internal RAM version  
 $\mu$ PD70F3474, 70F3475, 70F3476, 70F3477, 70F3478, 70F3479, 70F3480, 70F3481, 70F3482, 70F3486, 70F3487, 70F3488, 70F3925, 70F3926, 70F3927, 70F3934, 70F3935, 70F3936, 70F3937, 70F3938, and 70F3939

Table 1-2. V850ES/SJ3 Products

Function Part Number	ROM		RAM Size	Operating Frequency (MAX.)	i°C	Automotive LAN	Maskable Interrupts		Non-Maskable Interrupts
	Type	Size					External	Internal	
$\mu$ PD70F3344	Flash memory	384 KB	32 KB	32 MHz	On-chip	IEBus: 1 ch	9	64	2
$\mu$ PD70F3345		512 KB	40 KB						
$\mu$ PD70F3346		640 KB	48 KB						
$\mu$ PD70F3347		768 KB	60 KB						
$\mu$ PD70F3348		1024 KB	60 KB						
$\mu$ PD70F3354		384 KB	32 KB						
$\mu$ PD70F3355		512 KB	40 KB						
$\mu$ PD70F3356		640 KB	48 KB						
$\mu$ PD70F3357		768 KB	60 KB						
$\mu$ PD70F3358		1024 KB	60 KB						
$\mu$ PD70F3364		384 KB	32 KB			IEBus/CAN: 1 ch, CAN: 1 ch	68		
$\mu$ PD70F3365		512 KB	40 KB						
$\mu$ PD70F3366		640 KB	48 KB						
$\mu$ PD70F3367		768 KB	60 KB						
$\mu$ PD70F3368		1024 KB	60 KB						

## 1.2 Features

- Minimum instruction execution time: 20.8 ns (operating with 48 MHz)
- General-purpose registers: 32 bits  $\times$  32 registers
- CPU features:
  - Signed multiplication (16  $\times$  16  $\rightarrow$  32): 1 or 2 clocks
  - Signed multiplication (32  $\times$  32  $\rightarrow$  64): 1 or 2 clocks
  - Saturated operations (overflow and underflow detection functions included)
  - 32-bit shift instruction: 1 clock
  - Bit manipulation instructions
  - Load/store instructions with long/short format
  - Signed load instruction
- Memory space: 64 MB of linear address space (for programs and data)

&lt;R&gt;

External expansion: Up to approximately 30 MB

- Internal memory:
  - RAM: 60 KB (see **Table 1-1**)
  - Expanded internal RAM: 16/32 KB (see **Table 1-1**)
  - Flash memory: 512/768/1024/1280/1536 KB (see **Table 1-1**)
- External bus interface:
  - Separate bus/multiplexed bus output selectable
  - 8-/16-bit data bus sizing function
  - Wait function
    - Programmable wait function
    - External wait function
  - Idle state function
  - Bus hold function

&lt;R&gt;

- Interrupts and exceptions: Non-maskable interrupts: 2 sources
- <R> Maskable interrupts: 98/102/104/106/108/112 sources (see **Table 1-1**)
- Software exceptions: 32 sources
- Exception trap: 2 sources
- I/O lines: I/O ports: 128 (V850E/SJ3-H)  
156 (V850E/SK3-H)
- Timer function: 16-bit interval timer M (TMM): 3 channels  
16-bit timer/event counter P (TMP): 9 channels  
(TMP7 and TMP8 include the encoder count function)  
16-bit timer/event counter Q (TMQ): 1 channel  
Watch timer: 1 channel  
Real-time counter (RTC): 1 channel  
Watchdog timer: 1 channel
- Real-time output port: 6 bits × 2 channels
- Serial interface:
  - Asynchronous serial interface A (UARTA): 6 channels
  - Asynchronous serial interface B (UARTB): 2 channels
  - 3-wire variable length serial interface B (CSIB): 6 channels
  - 3-wire variable length serial interface E (CSIE):  
2 channels (Other than  $\mu$ PD70F3931 (V850E/SJ3-H), 70F3932 (V850E/SJ3-H), and 70F3933 (V850E/SJ3-H))
  - <R> 0 channels ( $\mu$ PD70F3931 (V850E/SJ3-H), 70F3932 (V850E/SJ3-H), and 70F3933 (V850E/SJ3-H) only)
  - I<sup>2</sup>C bus interface (I<sup>2</sup>C):  
6 channels (Other than  $\mu$ PD70F3931 (V850E/SJ3-H), 70F3932 (V850E/SJ3-H), and 70F3933 (V850E/SJ3-H))
  - <R> 4 channels ( $\mu$ PD70F3931 (V850E/SJ3-H), 70F3932 (V850E/SJ3-H), and 70F3933 (V850E/SJ3-H) only)
  - UARTA: 1 channel
  - UARTB: 2 channels
  - CSIB: 3 channels<sup>Note</sup>
  - CSIE:  
1 channel (Other than  $\mu$ PD70F3931 (V850E/SJ3-H), 70F3932 (V850E/SJ3-H), and 70F3933 (V850E/SJ3-H))
  - <R> 0 channels ( $\mu$ PD70F3931 (V850E/SJ3-H), 70F3932 (V850E/SJ3-H), and 70F3933 (V850E/SJ3-H) only)
  - I<sup>2</sup>C:  
2 channels (Other than  $\mu$ PD70F3931 (V850E/SJ3-H), 70F3932 (V850E/SJ3-H), and 70F3933 (V850E/SJ3-H))
  - <R> 1 channel ( $\mu$ PD70F3931 (V850E/SJ3-H), 70F3932 (V850E/SJ3-H), and 70F3933 (V850E/SJ3-H) only)
  - CSIB/I<sup>2</sup>C: 1 channel
  - UARTA/CSIB: 1 channel
  - UARTA/CSIE:  
1 channel (Other than  $\mu$ PD70F3931 (V850E/SJ3-H), 70F3932 (V850E/SJ3-H), and 70F3933 (V850E/SJ3-H))
  - <R> 0 channels ( $\mu$ PD70F3931 (V850E/SJ3-H), 70F3932 (V850E/SJ3-H), and 70F3933 (V850E/SJ3-H) only)
  - UARTA/ I<sup>2</sup>C: 2 channels<sup>Note</sup>

UARTA/CSIB/I<sup>2</sup>C:

1 channel (Other than  $\mu$ PD70F3931 (V850E/SJ3-H), 70F3932 (V850E/SJ3-H), and 70F3933 (V850E/SJ3-H))

<R> 0 channels ( $\mu$ PD70F3931 (V850E/SJ3-H), 70F3932 (V850E/SJ3-H), and 70F3933 (V850E/SJ3-H) only)

**Note** These channels can also be used in the following combinations.

CSIB: 2 channels

UARTA/I<sup>2</sup>C: 1 ch

CSIB (reception only)/UARTA/I<sup>2</sup>C: 1 channel

**Caution** In the V850E/SK3-H, serial interfaces can also be used in the following combinations.

**UARTA: 5 channels**

**UARTB: 2 channels**

**CSIB: 3 channels**

**CSIE: 2 channels**

**I<sup>2</sup>C: 4 channels**

**CSIB/I<sup>2</sup>C: 2 channels**

**UARTA/CSIB: 1 channel**

- IEBus controller: 1 channel
- CAN controller: 1/2 channels (CAN controller version only)
- A/D converter: 10-bit resolution: 16 channels
- D/A converter: 8-bit resolution: 2 channels
- DMA controller: 4 channels
- CRC function: Generates 16-bit error detection code for data in 8-bit units
- DCU (debug control unit): JTAG interface
- ROM correction: 8 correction addresses specifiable
- Clock generator: During main clock or subclock operation  
7-level CPU clock (f<sub>xx</sub>, f<sub>xx</sub>/2, f<sub>xx</sub>/4, f<sub>xx</sub>/8, f<sub>xx</sub>/16, f<sub>xx</sub>/32, f<sub>XT</sub>)  
Clock-through mode/PLL mode/SSCG mode selectable  
Clock generation function selectable by setting the option byte
- Internal oscillation clock: 220 kHz (TYP.)
- Power-save functions: HALT/IDLE1/IDLE2/STOP/subclock/sub-IDLE mode
- Package: 144-pin plastic LQFP (fine pitch) (20 × 20) (V850E/SJ3-H)  
176-pin plastic LQFP (fine pitch) (24 × 24) (V850E/SK3-H)

### 1.3 Application Fields

Automotive-use multimedia such as car audio systems

## 1.4 Ordering Information

### 1.4.1 V850E/SJ3-H

Part Number	Package	Internal ROM (Flash Memory)	Quality Grade
$\mu$ PD70F3474GJA-GAE-G	144-pin plastic LQFP (fine pitch) (20 × 20)	1280 KB	(A)
$\mu$ PD70F3475GJA-GAE-G			
$\mu$ PD70F3476GJA-GAE-G			
$\mu$ PD70F3477GJA-GAE-G		1536 KB	
$\mu$ PD70F3478GJA-GAE-G			
$\mu$ PD70F3479GJA-GAE-G			
<R> $\mu$ PD70F3931GJA-GAE-G		512 KB	
<R> $\mu$ PD70F3932GJA-GAE-G			
<R> $\mu$ PD70F3933GJA-GAE-G			
<R> $\mu$ PD70F3934GJA-GAE-G		768 KB	
<R> $\mu$ PD70F3935GJA-GAE-G			
<R> $\mu$ PD70F3936GJA-GAE-G			
<R> $\mu$ PD70F3937GJA-GAE-G		1024 KB	
<R> $\mu$ PD70F3938GJA-GAE-G			
<R> $\mu$ PD70F3939GJA-GAE-G			

**Remark** The V850E/SJ3-H microcontrollers are lead-free products.

Please refer to "Quality Grades on NEC Semiconductor Devices" (Document No. C11531E) published by NEC Electronics Corporation to know the specification of quality grade on the devices and its recommended applications.

## 1.4.2 V850E/SK3-H

Part Number	Package	Internal ROM (Flash Memory)	Quality Grade
$\mu$ PD70F3480GMA-GAR-G	176-pin plastic LQFP (fine pitch) (24 × 24)	1536 KB	(A)
$\mu$ PD70F3481GMA-GAR-G			
$\mu$ PD70F3482GMA-GAR-G			
$\mu$ PD70F3486GMA-GAR-G		1280 KB	
$\mu$ PD70F3487GMA-GAR-G			
$\mu$ PD70F3488GMA-GAR-G			
$\mu$ PD70F3925GMA-GAR-G		1024 KB	
$\mu$ PD70F3926GMA-GAR-G			
$\mu$ PD70F3927GMA-GAR-G			

**Remark** The V850E/SK3-H microcontrollers are lead-free products.

Please refer to "Quality Grades on NEC Semiconductor Devices" (Document No. C11531E) published by NEC Electronics Corporation to know the specification of quality grade on the devices and its recommended applications.

## 1.5 Pin Configuration (Top View)

## 1.5.1 V850E/SJ3-H

144-pin plastic LQFP (fine pitch) (20 × 20)

	$\mu$ PD70F3474GJA-GAE-G	$\mu$ PD70F3476GJA-GAE-G	$\mu$ PD70F3478GJA-GAE-G
	$\mu$ PD70F3475GJA-GAE-G	$\mu$ PD70F3477GJA-GAE-G	$\mu$ PD70F3479GJA-GAE-G
<R>	$\mu$ PD70F3931GJA-GAE-G	$\mu$ PD70F3932GJA-GAE-G	$\mu$ PD70F3933GJA-GAE-G
<R>	$\mu$ PD70F3934GJA-GAE-G	$\mu$ PD70F3935GJA-GAE-G	$\mu$ PD70F3936GJA-GAE-G
<R>	$\mu$ PD70F3937GJA-GAE-G	$\mu$ PD70F3938GJA-GAE-G	$\mu$ PD70F3939GJA-GAE-G

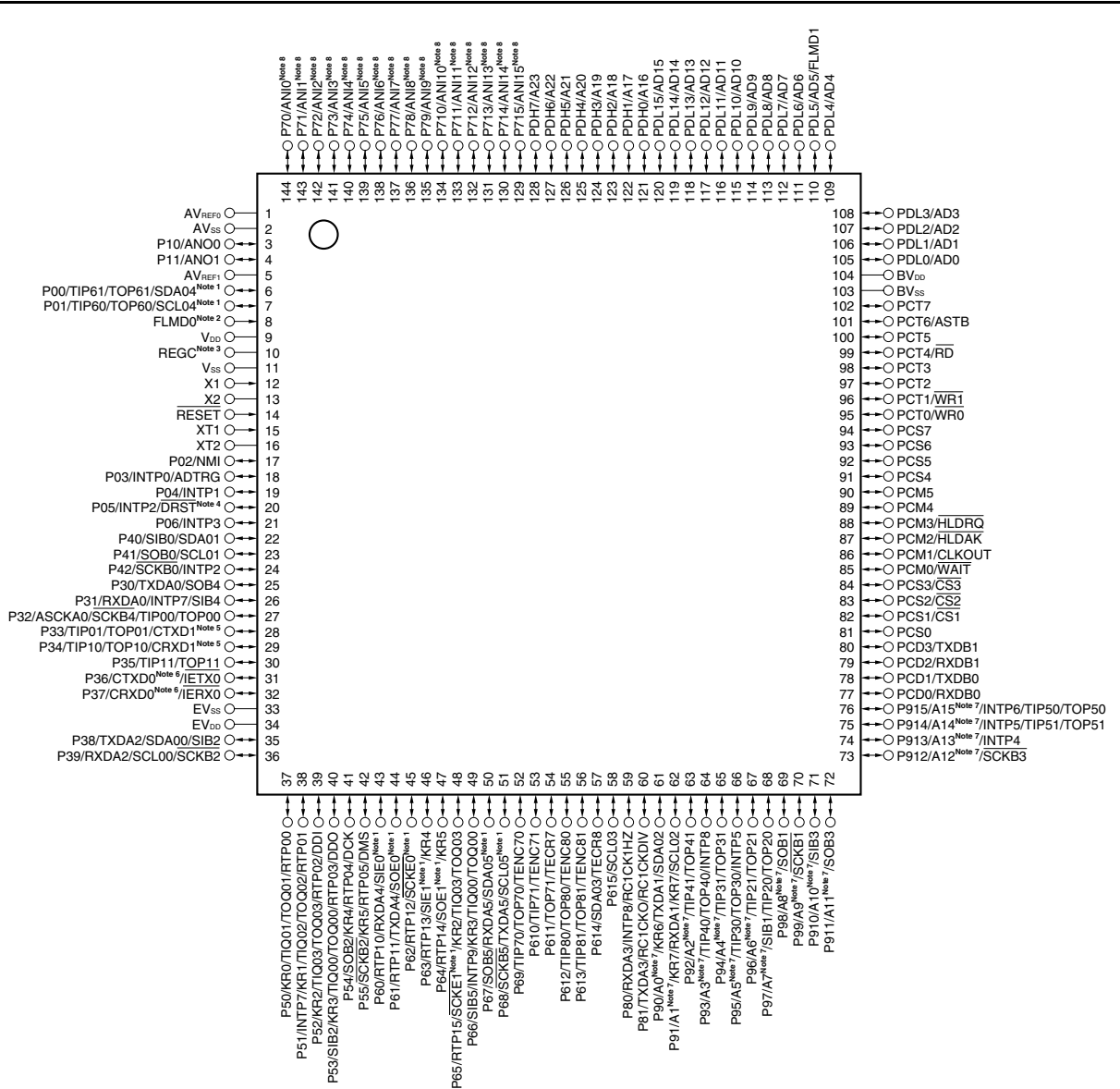

- <R> **Notes**
1. SIE0, SOE0, SCKE0, SIE1, SOE1, SCKE1, SCL04, SDA04, SCL05, and SDA05 are available only in products other than the  $\mu$ PD70F3931 (V850E/SJ3-H), 70F3932 (V850E/SJ3-H), and 70F3933 (V850E/SJ3-H).
  2. Set this pin to low level in the normal operation mode.
  3. Connect the REGC pin to Vss via a 4.7  $\mu$ F capacitor.
  4. Fix this pin to the low level from when the reset status has been released until the OCDM.OCDM0 bit is cleared (0) when the on-chip debug function is not used. For details, see **4.6.3 Cautions on on-chip debug pins**.  
In addition, this pin incorporates a pull-down resistor and it can be disconnected by clearing the OCDM.OCDM0 bit.
  5. CTXD1 and CRXD1 are valid only in the CAN controller (2-channel) version.
  6. CTXD0 and CRXD0 are valid only in the CAN controller version.
  7. Port 9 cannot be used as port pins or other alternate-function pins when the A0 to A15 pins are used in the separate bus mode.
  8. To use port 7 (P70/ANI0 to P715/ANI15) as A/D converter function pins and port I/O pins in mix, be sure to observe usage cautions (see **13.6 (4) Alternate I/O**).



**Pin names**

A0 to A23:	Address bus	$\overline{RD}$ :	Read strobe
AD0 to AD15:	Address/data bus	REGC:	Regulator control
ADTRG:	A/D trigger input	RESET:	Reset
ANI0 to ANI15:	Analog input	RTP00 to RTP05,	
ANO0, ANO1:	Analog output	RTP10 to RTP15:	Real-time output port
ASCKA0:	Asynchronous serial clock	RXDA0 to RXDA5,	
ASTB:	Address strobe	RXDB0, RXDB1:	Receive data
AVREF0, AVREF1:	Analog reference voltage	SCKB0 to SCKB5,	
AVSS:	Analog V <sub>SS</sub>	SCKE0, SCKE1:	Serial clock
BVDD:	Power supply for bus interface	SCL00 to SCL05:	Serial clock
BVSS:	Ground for bus interface	SDA00 to SDA05:	Serial data
CLKOUT:	Clock output	SIB0 to SIB5, SIE0, SIE1:	Serial input
CRXD0, CRXD1:	CAN receive data	SOB0 to SOB5, SOE0, SOE1:	Serial output
$\overline{CS1}$ to $\overline{CS3}$ :	Chip select	TECR7, TECR8:	Timer encoder clear input
CTXD0, CTXD1:	CAN transmit data	TENC70, TENC71,	
DCK:	Debug clock	TENC80, TENC81:	Timer encoder input
DDI:	Debug data input	TIP00, TIP01,	
DDO:	Debug data output	TIP10, TIP11,	
DMS:	Debug mode select	TIP20, TIP21,	
$\overline{DRST}$ :	Debug reset	TIP30, TIP31,	
EVDD:	Power supply for port	TIP40, TIP41,	
EVSS:	Ground for port	TIP50, TIP51,	
FLMD0, FLMD1:	Flash programming mode	TIP60, TIP61,	
$\overline{HLDK}$ :	Hold acknowledge	TIP70, TIP71,	
$\overline{HLDRQ}$ :	Hold request	TIP80, TIP81,	
$\overline{IERX0}$ :	IEBus receive data	TIQ00 to TIQ03:	Timer input
$\overline{IETX0}$ :	IEBus transmit data	TOP00, TOP01,	
INTP0 to INTP9:	External interrupt input	TOP10, TOP11,	
KR0 to KR7:	Key return	TOP20, TOP21,	
NMI:	Non-maskable interrupt request	TOP30, TOP31,	
P00 to P06:	Port 0	TOP40, TOP41,	
P10, P11:	Port 1	TOP50, TOP51,	
P30 to P39:	Port 3	TOP60, TOP61,	
P40 to P42:	Port 4	TOP70, TOP71,	
P50 to P55:	Port 5	TOP80, TOP81,	
P60 to P615:	Port 6	TOQ00 to TOQ03:	Timer output
P70 to P715:	Port 7	TXDA0 to TXDA5,	
P80, P81:	Port 8	TXDB0, TXDB1:	Transmit data
P90 to P915:	Port 9	V <sub>DD</sub> :	Power supply
PCD0 to PCD3:	Port CD	V <sub>SS</sub> :	Ground
PCM0 to PCM5:	Port CM	$\overline{WAIT}$ :	Wait
PCS0 to PCS7:	Port CS	$\overline{WRO}$ :	Lower byte write strobe
PCT0 to PCT7:	Port CT	$\overline{WR1}$ :	Upper byte write strobe
PDH0 to PDH7:	Port DH	X1, X2:	Crystal for main clock
PDL0 to PDL15:	Port DL	XT1, XT2:	Crystal for subclock
RC1CK1HZ,			
RC1CKDIV, RC1CKO:	Real-time counter clock output		

**1.5.2 V850E/SK3-H**

176-pin plastic LQFP (fine pitch) (24 × 24)

 $\mu$ PD70F3480GMA-GAR-G $\mu$ PD70F3481GMA-GAR-G $\mu$ PD70F3482GMA-GAR-G $\mu$ PD70F3486GMA-GAR-G $\mu$ PD70F3487GMA-GAR-G $\mu$ PD70F3488GMA-GAR-G $\mu$ PD70F3925GMA-GAR-G $\mu$ PD70F3926GMA-GAR-G $\mu$ PD70F3927GMA-GAR-G

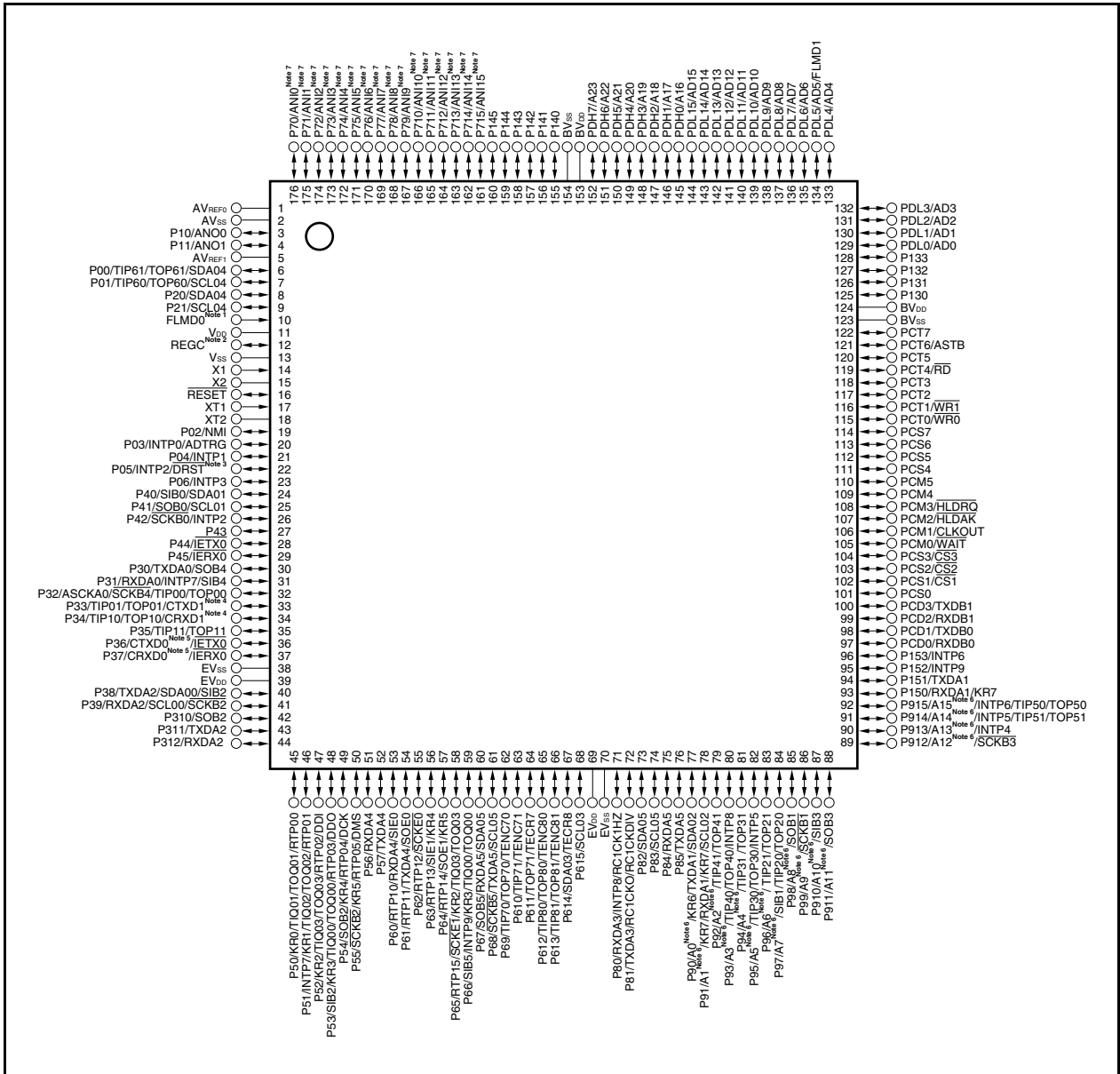

- Notes 1.** Set this pin to low level in the normal operation mode.
- 2.** Connect the REGC pin to Vss via a 4.7  $\mu$ F capacitor.
- 3.** Fix this pin to the low level from when the reset status has been released until the OCDM.OCDM0 bit is cleared (0) when the on-chip debug function is not used. For details, see **4.6.3 Cautions on on-chip debug pins**.  
 In addition, this pin incorporates a pull-down resistor and it can be disconnected by clearing the OCDM.OCDM0 bit.
- 4.** CTXD1 and CRXD1 are valid only in the CAN controller (2-channel) version.
- 5.** CTXD0 and CRXD0 are valid only in the CAN controller version.
- 6.** Port 9 cannot be used as port pins or other alternate-function pins when the A0 to A15 pins are used in the separate bus mode.
- 7.** To use port 7 (P70/ANI0 to P715/ANI15) as A/D converter function pins and port I/O pins in mix, be sure to observe usage cautions (see **13.6 (4) Alternate I/O**).

**Pin names**

A0 to A23:	Address bus	PDL0 to PDL15:	Port DL
AD0 to AD15:	Address/data bus	RC1CK1HZ, RC1CKDIV,	
ADTRG:	A/D trigger input	RC1CKO:	Real-time counter clock output
ANI0 to ANI15:	Analog input	$\overline{\text{RD}}$ :	Read strobe
ANO0, ANO1:	Analog output	REGC:	Regulator control
ASCKA0:	Asynchronous serial clock	$\overline{\text{RESET}}$ :	Reset
ASTB:	Address strobe	RTP00 to RTP05,	
AV <sub>REF0</sub> , AV <sub>REF1</sub> :	Analog reference voltage	RTP10 to RTP15:	Real-time output port
AV <sub>SS</sub> :	Analog V <sub>SS</sub>	RXDA0 to RXDA5,	
BV <sub>DD</sub> :	Power supply for bus interface	RXDB0, RXDB1:	Receive data
BV <sub>SS</sub> :	Ground for bus interface	$\overline{\text{SCKB0}}$ to $\overline{\text{SCKB5}}$ ,	
CLKOUT:	Clock output	$\overline{\text{SCKE0}}$ , $\overline{\text{SCKE1}}$ :	Serial clock
CRXD0, CRXD1:	CAN receive data	SCL00 to SCL05:	Serial clock
$\overline{\text{CS1}}$ to $\overline{\text{CS3}}$ :	Chip select	SDA00 to SDA05:	Serial data
CTXD0, CTXD1:	CAN transmit data	SIB0 to SIB5, SIE0, SIE1:	Serial input
DCK:	Debug clock	SOB0 to SOB5, SOE0, SOE1:	Serial output
DDI:	Debug data input	TECR7, TECR8:	Timer encoder clear input
DDO:	Debug data output	TENC70, TENC71,	
DMS:	Debug mode select	TENC80, TENC81:	Timer encoder input
$\overline{\text{DRST}}$ :	Debug reset	TIP00, TIP01,	
EV <sub>DD</sub> :	Power supply for port	TIP10, TIP11,	
EV <sub>SS</sub> :	Ground for port	TIP20, TIP21,	
FLMD0, FLMD1:	Flash programming mode	TIP30, TIP31,	
$\overline{\text{HLDK}}$ :	Hold acknowledge	TIP40, TIP41,	
$\overline{\text{HLDRQ}}$ :	Hold request	TIP50, TIP51,	
$\overline{\text{IERX0}}$ :	IEBus receive data	TIP60, TIP61,	
$\overline{\text{IETX0}}$ :	IEBus transmit data	TIP70, TIP71,	
INTP0 to INTP9:	External interrupt input	TIP80, TIP81,	
KR0 to KR7:	Key return	TIQ00 to TIQ03:	Timer input
NMI:	Non-maskable interrupt request	TOP00, TOP01,	
P00 to P06:	Port 0	TOP10, TOP11,	
P10, P11:	Port 1	TOP20, TOP21,	
P20, P21:	Port 2	TOP30, TOP31,	
P30 to P312:	Port 3	TOP40, TOP41,	
P40 to P45:	Port 4	TOP50, TOP51,	
P50 to P57:	Port 5	TOP60, TOP61,	
P60 to P615:	Port 6	TOP70, TOP71,	
P70 to P715:	Port 7	TOP80, TOP81,	
P80 to P85:	Port 8	TOQ00 to TOQ03:	Timer output
P90 to P915:	Port 9	TXDA0 to TXDA5,	
P130 to P133:	Port 13	TXDB0, TXDB1:	Transmit data
P140 to P145:	Port 14	V <sub>DD</sub> :	Power supply
P150 to P153:	Port 15	V <sub>SS</sub> :	Ground
PCD0 to PCD3:	Port CD	$\overline{\text{WAIT}}$ :	Wait
PCM0 to PCM5:	Port CM	$\overline{\text{WR0}}$ :	Lower byte write strobe
PCS0 to PCS7:	Port CS	$\overline{\text{WR1}}$ :	Upper byte write strobe
PCT0 to PCT7:	Port CT	X1, X2:	Crystal for main clock
PDH0 to PDH7:	Port DH	XT1, XT2:	Crystal for subclock

## 1.6 Function Block Configuration

### 1.6.1 Internal block diagram

#### (1) V850E/SJ3-H

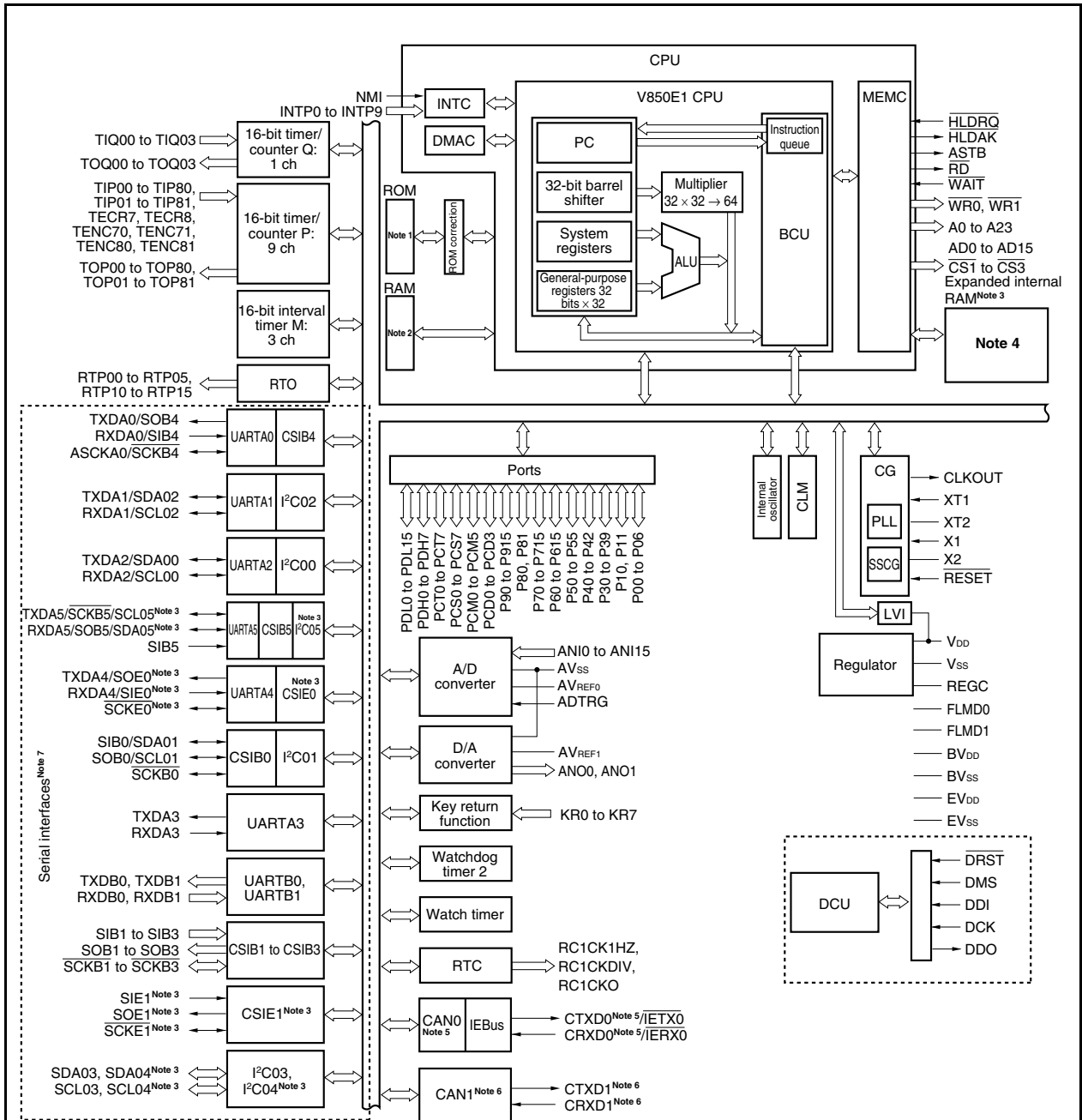

<R>

**Notes 1.** 512/768/1024/1280/1536 KB (flash memory) (see **Table 1-1**)

**2.** 60 KB (see **Table 1-1**)

<R>

**3.** Not available in the  $\mu$ PD70F3931 (V850E/SJ3-H), 70F3932 (V850E/SJ3-H), and 70F3933 (V850E/SJ3-H)

**4.** 16/32 KB (see **Table 1-1**)

**5.** CAN controller version only

**6.** CAN controller (2-channel) version only

**Notes 7.** Another type of the block diagram is available in accordance with the combination of port sharing.

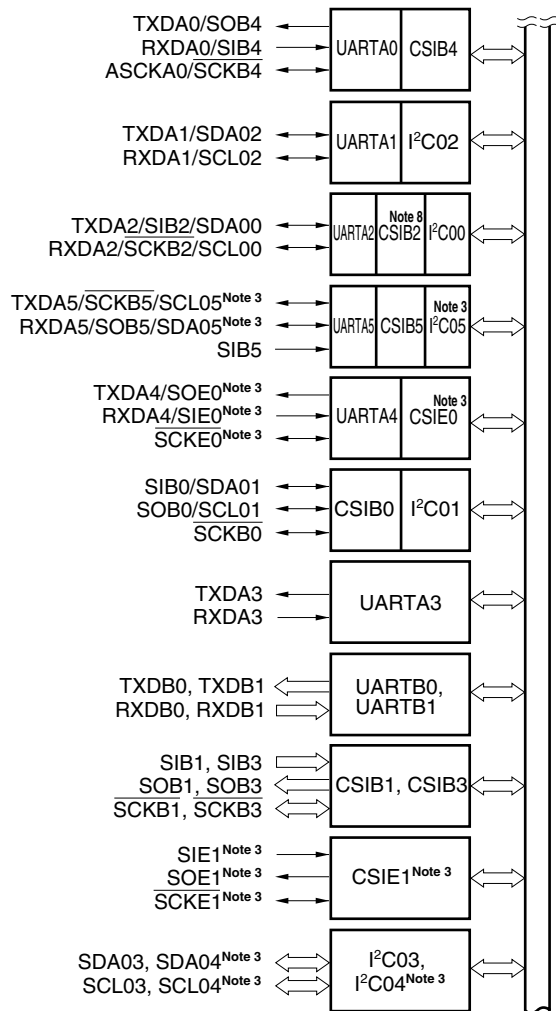

**8.** The serial transmit data output pin (SOB2) is not provided.

(2) V850E/SK3-H

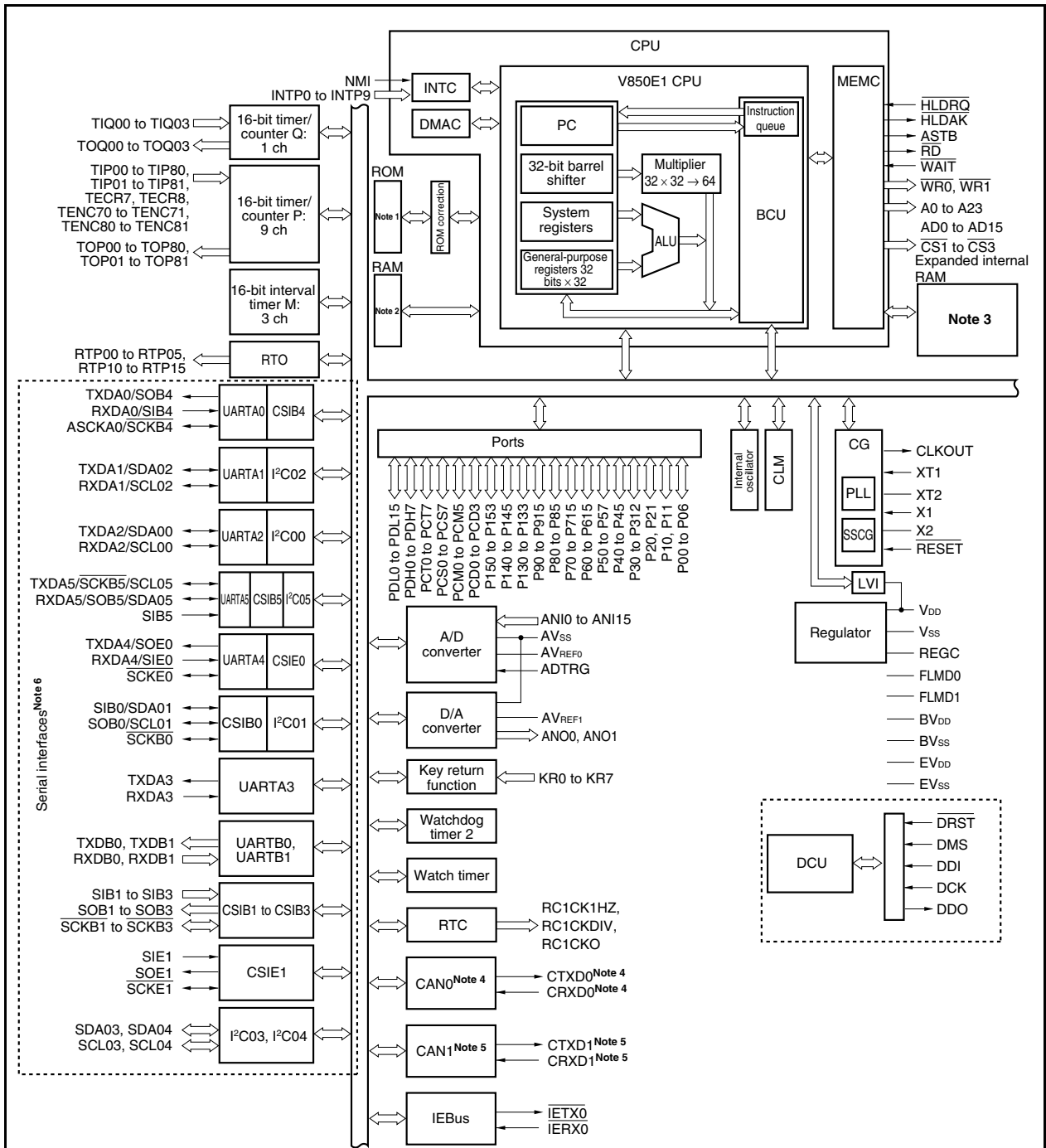

- Notes 1.** 1024/1280/1536 KB (flash memory) (see **Table 1-1**)  
**2.** 60 KB (see **Table 1-1**)  
**3.** 16/32 KB (see **Table 1-1**)  
**4.** CAN controller version only  
**5.** CAN controller (2-channel) version only

**Note 6.** An example of port sharing combinations is shown in the following block diagram.

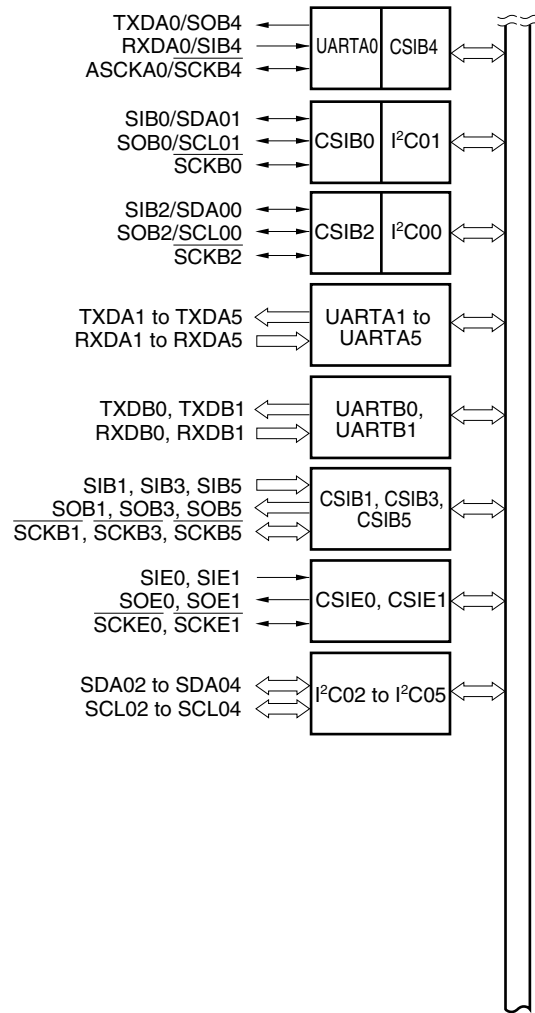



## 1.6.2 Internal units

### (1) CPU

The CPU uses five-stage pipeline control to enable single-clock execution of address calculations, arithmetic logic operations, data transfers, and almost all other instruction processing.

Other dedicated on-chip hardware, such as a multiplier (32 bits × 32 bits → 64 bits) and a barrel shifter (32 bits) contribute to faster complex processing.

### (2) Bus control unit (BCU)

The BCU starts a required external bus cycle based on the physical address obtained by the CPU. When an instruction is fetched from external memory space and the CPU does not send a bus cycle start request, the BCU generates a prefetch address and prefetches the instruction code. The prefetched instruction code is stored in a CPU internal instruction queue.

The BCU controls a memory controller (MEMC) and accesses an external memory and an expanded internal RAM.

#### (a) Memory controller (MEMC)

Controls access to SRAM, external ROM, and external I/O.

<R>

### (3) ROM

This is a 1536/1280/1024/768/512 KB flash memory mapped to addresses 0000000H to 017FFFFH/0000000H to 013FFFFH/0000000H to 00FFFFFH/0000000H to 00BFFFFH/0000000H to 007FFFFH. It can be accessed from the CPU in one clock during instruction fetch.

### (4) RAM

This is a 60 KB RAM mapped to addresses 3FF0000H to 3FFEFFFH. It can be accessed from the CPU in one clock during data access.

### (5) Expanded internal RAM

This is a 32/16 KB RAM mapped to addresses 3FE4000H to 3FEBFFFH/3FE8000H to 3FEBFFFH. The expanded internal RAM can be accessed in 3 bus cycles (min.).

### (6) Interrupt controller (INTC)

This controller handles hardware interrupt requests (NMI, INTPO to INTP9) from on-chip peripheral hardware and external hardware. Eight levels of interrupt priorities can be specified for these interrupt requests, and multiple servicing control can be performed.

<R>

### (7) Clock generator (CG)

A main clock oscillator that generates the main clock oscillation frequency ( $f_x$ ) and a subclock oscillator that generates the subclock oscillation frequency ( $f_{XT}$ ) are available. As the main clock frequency, PLL input clock frequency ( $f_{PLL}$ ) is used as it is in the clock-through mode, is multiplied by eight or divided by 2 after multiplied by eight in the PLL mode, and is multiplied by eight or twelve in the SSCG mode.

The CPU clock frequency ( $f_{CPU}$ ) can be selected from seven types:  $f_{xx}$ ,  $f_{xx}/2$ ,  $f_{xx}/4$ ,  $f_{xx}/8$ ,  $f_{xx}/16$ ,  $f_{xx}/32$ , and  $f_{XT}$ . As the peripheral clock frequency ( $f_{XP}$ ), the main clock frequency ( $f_{xx}$ ) is used in the PLL mode, and the  $f_{PLL}$  multiplied by eight or divided by 2 after multiplied by eight with PLL is used in the SSCG mode.

**(8) Internal oscillator**

An internal oscillator is provided on chip. The oscillation frequency is 220 kHz (TYP.). An internal oscillator supplies the clock for watchdog timer 2 and timer M.

**(9) Timer/counter**

Nine-channel 16-bit timer/event counter P (TMP) (encoder count function is provided for TMP7 and TMP8), one-channel 16-bit timer/event counter Q (TMQ), and three-channel 16-bit interval timer M (TMM) are provided on chip.

**(10) Watch timer**

This timer counts the reference time period (0.5 s or 0.25 s) for counting the clock (the 32.768 kHz from the subclock or the 32.768 kHz  $f_{BRG}$  from prescaler 3). The watch timer can also be used as an interval timer for the main clock.

**(11) Real-time counter (for watch)**

The real-time counter counts the reference time (1 second) from the subclock (32.768 kHz) or main clock for watch counting. This can also be used as the interval timer based on the main clock at the same time. Dedicated hardware counters for year, month, week, day, hour, minute, and second are provided, and the real-time counter can count up to 99 years.

**(12) Watchdog timer 2**

A watchdog timer is provided on chip to detect inadvertent program loops, system abnormalities, etc. Either the internal oscillation clock, the main clock, or the subclock can be selected as the source clock. Watchdog timer 2 generates a non-maskable interrupt request signal (INTWDT2) or a system reset signal (WDT2RES) after an overflow occurs. With the option byte function, the operation mode of watchdog timer 2 can be fixed to the reset mode.

**(13) Serial interface**

The V850E/SJ3-H and V850E/SK3-H include five kinds of serial interfaces: asynchronous serial interface A (UARTA), asynchronous serial interface B (UARTB), 3-wire variable-length serial interface B (CSIB), 3-wire variable-length serial interface E (CSIE), and an I<sup>2</sup>C bus interface (I<sup>2</sup>C).

In the case of UARTA, data is transferred via the TXDA0 to TXDA5 pins and RXDA0 to RXDA5 pins.

In the case of UARTB, data is transferred via the TXDB0 and TXDB1 pins and RXDB0 and RXDB1 pins.

In the case of CSIB, data is transferred via the SOB0 to SOB5 pins, SIB0 to SIB5 pins, and  $\overline{\text{SCKB0}}$  to  $\overline{\text{SCKB5}}$  pins.

<R> In the case of CSIE, data is transferred via the SOE0<sup>Note</sup>, SOE1<sup>Note</sup>, SIE0<sup>Note</sup>, SIE1<sup>Note</sup>,  $\overline{\text{SCKE0}}$ <sup>Note</sup>, and  $\overline{\text{SCKE1}}$ <sup>Note</sup> pins.

<R> In the case of I<sup>2</sup>C, data is transferred via the SDA00 to SDA03, SDA04<sup>Note</sup>, SDA05<sup>Note</sup>, SCL00 to SCL03, SCL04<sup>Note</sup>, and SCL05<sup>Note</sup> pins.

<R> **Note** Not available in the  $\mu$ PD70F3931 (V850E/SJ3-H), and 70F3932 (V850E/SJ3-H), 70F3933 (V850E/SJ3-H).

**(14) IEBus controller**

The IEBus controller is a small-scale digital data transmission system for transferring data between units.

**(15) CAN controller**

The CAN controller is a small-scale digital data transmission system for transferring data between units.

The CAN controller is provided only in the CAN controller version (see **Table 1-1**).

**(16) A/D converter**

This 10-bit A/D converter includes 16 analog input pins. Conversion is performed using the successive approximation method.

**(17) D/A converter**

A two-channel, 8-bit-resolution D/A converter that uses the R-2R ladder method is provided on chip.

**(18) DMA controller**

A 4-channel DMA controller is provided on chip. This controller transfers data between the internal RAM, on-chip peripheral I/O, external memories, and expanded internal RAM in response to interrupt requests sent by on-chip peripheral I/O.

**(19) ROM correction**

A ROM correction function that replaces part of a program in the internal ROM with a program in the internal RAM is provided. Up to eight correction addresses can be specified.

**(20) Key interrupt function**

A key interrupt request signal (INTKR) can be generated by inputting a falling edge to key input pins (8 channels).

**(21) Real-time output function**

The real-time output function transfers preset 6-bit data to output latches upon the occurrence of a timer compare register match signal.

**(22) CRC function**

A CRC operation circuit that generates 16-bit CRC (Cyclic Redundancy Check) code upon setting of 8-bit data is provided on chip.

**(23) DCU (debug control unit)**

An on-chip debug function via an on-chip debug emulator that uses the JTAG (Joint Test Action Group) communication specifications is provided. Switching between the normal port function and on-chip debugging function is done with the control pin input level and the on-chip debug mode register (OCDM).

**(24) Ports**

The general-purpose port functions and control pin functions are listed below.

Port	I/O	Alternate Function
<R> P0	7-bit I/O	Timer I/O, serial interface <sup>Note 2</sup> , NMI, external interrupt, A/D converter trigger, debug reset
P1	2-bit I/O	D/A converter analog output
P2 <sup>Note 1</sup>	2-bit I/O (V850E/SK3-H)	Serial interface
P3	10-bit I/O (V850E/SJ3-H) 13-bit I/O (V850E/SK3-H)	External interrupt, serial interface, timer I/O, CAN data I/O <sup>Note 3</sup> , IEBus data I/O
P4	3-bit I/O (V850E/SJ3-H) 6-bit I/O (V850E/SK3-H)	Serial interface, external interrupt, IEBus data I/O <sup>Note 1</sup>
P5	6-bit I/O (V850E/SJ3-H) 8-bit I/O (V850E/SK3-H)	Timer I/O, real-time output, key interrupt input, external interrupt, serial interface, debug I/O
P6	16-bit I/O	Real-time output, serial interface, timer I/O, encoder input, key interrupt input, external interrupt
P7	16-bit I/O	A/D converter analog input
P8	2-bit I/O (V850E/SJ3-H) 6-bit I/O (V850E/SK3-H)	Serial interface, external interrupt, real-time counter output
P9	16-bit I/O	External address bus, serial interface, key interrupt input, timer I/O, external interrupt
P13 <sup>Note 1</sup>	4-bit I/O (V850E/SK3-H)	–
P14 <sup>Note 1</sup>	6-bit I/O (V850E/SK3-H)	–
P15 <sup>Note 1</sup>	4-bit I/O (V850E/SK3-H)	Serial interface, external interrupt, key interrupt input
PCD	4-bit I/O	Serial interface
PCM	6-bit I/O	External control signal
PCS	8-bit I/O	Chip select output
PCT	8-bit I/O	External control signal
PDH	8-bit I/O	External address bus
PDL	16-bit I/O	External address/data bus, flash memory programming mode input signal

**Notes** 1. V850E/SK3-H only

- <R> 2. Not available in the  $\mu$ PD70F3931 (V850E/SJ3-H), 70F3932 (V850E/SJ3-H), and 70F3933 (V850E/SJ3-H)
3. CAN controller version only

## CHAPTER 2 PIN FUNCTIONS

### 2.1 List of Pin Functions

The names and functions of the pins of the V850E/SJ3-H and V850E/SK3-H are described below.

There are four types of pin I/O buffer power supplies:  $AV_{REF0}$ ,  $AV_{REF1}$ ,  $BV_{DD}$ , and  $EV_{DD}$ . The relationship between these power supplies and the pins is described below.

**Table 2-1. Pin I/O Buffer Power Supplies**

**(a) V850E/SJ3-H**

Power Supply	Corresponding Pins
$AV_{REF0}$	Port 7
$AV_{REF1}$	Port 1
$BV_{DD}$	Ports CD, CM, CS, CT, DH, DL
$EV_{DD}$	$\overline{\text{RESET}}$ , ports 0, 3 to 6, 8, 9

**(b) V850E/SK3-H**

Power Supply	Corresponding Pins
$AV_{REF0}$	Port 7
$AV_{REF1}$	Port 1
$BV_{DD}$	Ports 13, 14, CD, CM, CS, CT, DH, DL
$EV_{DD}$	$\overline{\text{RESET}}$ , ports 0, 2 to 6, 8, 9, 15

## (1) Port pins

(1/6)

	Pin Name	Pin No.		I/O	Function	Alternate Function
		SJ3-H	SK3-H			
		GJ	GM			
<R>	P00	6	6	I/O	Port 0 7-bit I/O port Input/output can be specified in 1-bit units. N-ch open-drain output can be specified in 1-bit units. 5 V tolerant.	TIP61/TOP61/SDA04 <sup>Note 3</sup>
<R>	P01	7	7			TIP60/TOP60/SCL04 <sup>Note 3</sup>
	P02	17	19			NMI
	P03	18	20			INTP0/ADTRG
	P04	19	21			INTP1
	P05 <sup>Note 1</sup>	20	22			INTP2/DRST
	P06	21	23			INTP3
	P10	3	3	I/O	Port 1 2-bit I/O port Input/output can be specified in 1-bit units.	ANO0
	P11	4	4			ANO1
	P20 <sup>Note 2</sup>	–	8	I/O	Port 2 (V850E/SK3-H only) 2-bit I/O port Input/output can be specified in 1-bit units. N-ch open-drain output can be specified in 1-bit units. 5 V tolerant.	SDA04 <sup>Note 2</sup>
	P21 <sup>Note 2</sup>	–	9			SCL04 <sup>Note 2</sup>
	P30	25	30	I/O	Port 3 V850E/SJ3-H: 10-bit I/O port V850E/SK3-H: 13-bit I/O port Input/output can be specified in 1-bit units. N-ch open-drain output can be specified in 1-bit units. 5 V tolerant.	TXDA0/SOB4
	P31	26	31			RXDA0/INTP7/SIB4
	P32	27	32			ASCKA0/SCKB4/TIP00/TOP00
	P33	28	33			TIP01/TOP01/CTXD1 <sup>Note 4</sup>
	P34	29	34			TIP10/TOP10/CRXD1 <sup>Note 4</sup>
	P35	30	35			TIP11/TOP11
	P36	31	36			CTXD0 <sup>Note 5</sup> /IETX0
	P37	32	37			CRXD0 <sup>Note 5</sup> /IERX0
	P38	35	40			TXDA2/SDA00/SIB2
	P39	36	41			RXDA2/SCL00/SCKB2
	P310 <sup>Note 2</sup>	–	42			SOB2 <sup>Note 2</sup>
	P311 <sup>Note 2</sup>	–	43			TXDA2 <sup>Note 2</sup>
	P312 <sup>Note 2</sup>	–	44			RXDA2 <sup>Note 2</sup>

**Notes 1.** Fix this pin to the low level from when the reset status has been released until the OCDM.OCDM0 bit is cleared (0) when the on-chip debug function is not used. For details, see **4.6.3 Cautions on on-chip debug pins**. In addition, this pin incorporates a pull-down resistor and it can be disconnected by clearing the OCDM.OCDM0 bit.

**2.** V850E/SK3-H only

<R> **3.** Not available in the  $\mu$ PD70F3931 (V850E/SJ3-H), 70F3932 (V850E/SJ3-H), and 70F3933 (V850E/SJ3-H)

**4.** CAN controller (2-channel) version only

**5.** CAN controller version only

**Remark** SJ3-H: V850E/SJ3-H

SK3-H: V850E/SK3-H

GJ (V850E/SJ3-H): 144-pin plastic LQFP (fine pitch) (20 × 20)

GM (V850E/SK3-H): 176-pin plastic LQFP (fine pitch) (24 × 24)

Pin Name	Pin No.		I/O	Function	Alternate Function
	SJ3-H	SK3-H			
	GJ	GM			
P40	22	24	I/O	Port 4 V850E/SJ3-H: 3-bit I/O port V850E/SK3-H: 6-bit I/O port Input/output can be specified in 1-bit units. N-ch open-drain output can be specified in 1-bit units. 5 V tolerant.	SIB0/SDA01
P41	23	25			SOB0/SCL01
P42	24	26			SCKB0/INTP2
P43 <sup>Note 1</sup>	–	27			–
P44 <sup>Note 1</sup>	–	28			IETX0 <sup>Note 1</sup>
P45 <sup>Note 1</sup>	–	29			IERX0 <sup>Note 1</sup>
P50	37	45	I/O	Port 5 V850E/SJ3-H: 6-bit I/O port V850E/SK3-H: 8-bit I/O port Input/output can be specified in 1-bit units. N-ch open-drain output can be specified in 1-bit units. 5 V tolerant.	KR0/TIQ01/TOQ01/RTP00
P51	38	46			INTP7/KR1/TIQ02/TOQ02/RTP01
P52	39	47			KR2/TIQ03/TOQ03/RTP02/DDI
P53	40	48			SIB2/KR3/TIQ00/TOQ00/RTP03/DDO
P54	41	49			SOB2/KR4/RTP04/DCK
P55	42	50			SCKB2/KR5/RTP05/DMS
P56 <sup>Note 1</sup>	–	51			RXDA4 <sup>Note 1</sup>
P57 <sup>Note 1</sup>	–	52			TXDA4 <sup>Note 1</sup>
<R> P60	43	53	I/O	Port 6 16-bit I/O port Input/output can be specified in 1-bit units. N-ch open-drain output can be specified in 1-bit units. 5 V tolerant.	RTP10/RXDA4/SIE0 <sup>Note 2</sup>
<R> P61	44	54			RTP11/TXDA4/SOE0 <sup>Note 2</sup>
<R> P62	45	55			RTP12/SCKE0 <sup>Note 2</sup>
<R> P63	46	56			RTP13/SIE1 <sup>Note 2</sup> /KR4
<R> P64	47	57			RTP14/SOE1 <sup>Note 2</sup> /KR5
<R> P65	48	58			RTP15/SCKE1 <sup>Note 2</sup> /KR2/TIQ03/TOQ03
P66	49	59			SIB5/INTP9/KR3/TIQ00/TOQ00
<R> P67	50	60			SOB5/RXDA5/SDA05 <sup>Note 2</sup>
<R> P68	51	61			SCKB5/TXDA5/SCL05 <sup>Note 2</sup>
P69	52	62			TIP70/TOP70/TENC70
P610	53	63			TIP71/TENC71
P611	54	64			TOP71/TECR7
P612	55	65			TIP80/TOP80/TENC80
P613	56	66			TIP81/TOP81/TENC81
P614	57	67			SDA03/TECR8
P615	58	68	SCL03		

**Notes 1.** V850E/SK3-H only

<R> **2.** Not available in the  $\mu$ PD70F3931 (V850E/SJ3-H), 70F3932 (V850E/SJ3-H), and 70F3933 (V850E/SJ3-H)

**Remark** SJ3-H: V850E/SJ3-H

SK3-H: V850E/SK3-H

GJ (V850E/SJ3-H): 144-pin plastic LQFP (fine pitch) (20 × 20)

GM (V850E/SK3-H): 176-pin plastic LQFP (fine pitch) (24 × 24)

Pin Name	Pin No.		I/O	Function	Alternate Function
	SJ3-H	SK3-H			
	GJ	GM			
P70	144	176	I/O	Port 7 16-bit I/O port Input/output can be specified in 1-bit units.	ANI0
P71	143	175			ANI1
P72	142	174			ANI2
P73	141	173			ANI3
P74	140	172			ANI4
P75	139	171			ANI5
P76	138	170			ANI6
P77	137	169			ANI7
P78	136	168			ANI8
P79	135	167			ANI9
P710	134	166			ANI10
P711	133	165			ANI11
P712	132	164			ANI12
P713	131	163			ANI13
P714	130	162			ANI14
P715	129	161	ANI15		
P80	59	71	I/O	Port 8 V850E/SJ3-H: 2-bit I/O port V850E/SK3-H: 6-bit I/O port Input/output can be specified in 1-bit units. N-ch open-drain output can be specified in 1-bit units. 5 V tolerant.	RXDA3/INTP8/RC1CK1HZ
P81	60	72			TXDA3/RC1CKO/RC1CKDIV
P82 <sup>Note</sup>	–	73			SDA05 <sup>Note</sup>
P83 <sup>Note</sup>	–	74			SCL05 <sup>Note</sup>
P84 <sup>Note</sup>	–	75			RXDA5 <sup>Note</sup>
P85 <sup>Note</sup>	–	76	TXDA5 <sup>Note</sup>		

**Note** V850E/SK3-H only

**Remark** SJ3-H: V850E/SJ3-H

SK3-H: V850E/SK3-H

GJ (V850E/SJ3-H): 144-pin plastic LQFP (fine pitch) (20 × 20)

GM (V850E/SK3-H): 176-pin plastic LQFP (fine pitch) (24 × 24)



Pin Name	Pin No.		I/O	Function	Alternate Function
	SJ3-H	SK3-H			
	GJ	GM			
P90	61	77	I/O	Port 9 16-bit I/O port Input/output can be specified in 1-bit units. N-ch open-drain output can be specified in 1-bit units. 5 V tolerant.	A0/KR6/TXDA1/SDA02
P91	62	78			A1/KR7/RXDA1/KR7/SCL02
P92	63	79			A2/TIP41/TOP41
P93	64	80			A3/TIP40/TOP40/INTP8
P94	65	81			A4/TIP31/TOP31
P95	66	82			A5/TIP30/TOP30/INTP5
P96	67	83			A6/TIP21/TOP21
P97	68	84			A7/SIB1/TIP20/TOP20
P98	69	85			A8/SOB1
P99	70	86			A9/SCKB1
P910	71	87			A10/SIB3
P911	72	88			A11/SOB3
P912	73	89			A12/SCKB3
P913	74	90			A13/INTP4
P914	75	91			A14/INTP5/TIP51/TOP51
P915	76	92	A15/INTP6/TIP50/TOP50		
P130 <sup>Note</sup>	–	125	I/O	Port 13 (V850E/SK3-H only) 4-bit I/O port Input/output can be specified in 1-bit units.	–
P131 <sup>Note</sup>	–	126			–
P132 <sup>Note</sup>	–	127			–
P133 <sup>Note</sup>	–	128			–
P140 <sup>Note</sup>	–	155	I/O	Port 14 (V850E/SK3-H only) 6-bit I/O port Input/output can be specified in 1-bit units.	–
P141 <sup>Note</sup>	–	156			–
P142 <sup>Note</sup>	–	157			–
P143 <sup>Note</sup>	–	158			–
P144 <sup>Note</sup>	–	159			–
P145 <sup>Note</sup>	–	160			–
P150 <sup>Note</sup>	–	93	I/O	Port 15 (V850E/SK3-H only) 4-bit I/O port Input/output can be specified in 1-bit units. N-ch open-drain output can be specified in 1-bit units. 5 V tolerant.	RXDA1 <sup>Note</sup> /KR7 <sup>Note</sup>
P151 <sup>Note</sup>	–	94			TXDA1 <sup>Note</sup>
P152 <sup>Note</sup>	–	95			INTP9 <sup>Note</sup>
P153 <sup>Note</sup>	–	96			INTP6 <sup>Note</sup>

**Note** V850E/SK3-H only

**Remark** SJ3-H: V850E/SJ3-H

SK3-H: V850E/SK3-H

GJ (V850E/SJ3-H): 144-pin plastic LQFP (fine pitch) (20 × 20)

GM (V850E/SK3-H): 176-pin plastic LQFP (fine pitch) (24 × 24)

Pin Name	Pin No.		I/O	Function	Alternate Function
	SJ3-H	SK3-H			
	GJ	GM			
PCD0	77	97	I/O	Port CD 4-bit I/O port Input/output can be specified in 1-bit units.	RXDB0
PCD1	78	98			TXDB0
PCD2	79	99			RXDB1
PCD3	80	100			TXDB1
PCM0	85	105	I/O	Port CM 6-bit I/O port Input/output can be specified in 1-bit units.	WAIT
PCM1	86	106			CLKOUT
PCM2	87	107			HLDAK
PCM3	88	108			HLDRQ
PCM4	89	109			–
PCM5	90	110			–
PCS0	81	101	I/O	Port CS 8-bit I/O port Input/output can be specified in 1-bit units.	–
PCS1	82	102			CS1
PCS2	83	103			CS2
PCS3	84	104			CS3
PCS4	91	111			–
PCS5	92	112			–
PCS6	93	113			–
PCS7	94	114			–
PCT0	95	115	I/O	Port CT 8-bit I/O port Input/output can be specified in 1-bit units.	WR0
PCT1	96	116			WR1
PCT2	97	117			–
PCT3	98	118			–
PCT4	99	119			RD
PCT5	100	120			–
PCT6	101	121			ASTB
PCT7	102	122			–
PDH0	121	145	I/O	Port DH 8-bit I/O port Input/output can be specified in 1-bit units.	A16
PDH1	122	146			A17
PDH2	123	147			A18
PDH3	124	148			A19
PDH4	125	149			A20
PDH5	126	150			A21
PDH6	127	151			A22
PDH7	128	152			A23

**Remark** SJ3-H: V850E/SJ3-H  
SK3-H: V850E/SK3-H  
GJ (V850E/SJ3-H): 144-pin plastic LQFP (fine pitch) (20 × 20)  
GM (V850E/SK3-H): 176-pin plastic LQFP (fine pitch) (24 × 24)

Pin Name	Pin No.		I/O	Function	Alternate Function
	SJ3-H	SK3-H			
	GJ	GM			
PDL0	105	129	I/O	Port DH 16-bit I/O port Input/output can be specified in 1-bit units.	AD0
PDL1	106	130			AD1
PDL2	107	131			AD2
PDL3	108	132			AD3
PDL4	109	133			AD4
PDL5	110	134			AD5/FLMD1
PDL6	111	135			AD6
PDL7	112	136			AD7
PDL8	113	137			AD8
PDL9	114	138			AD9
PDL10	115	139			AD10
PDL11	116	140			AD11
PDL12	117	141			AD12
PDL13	118	142			AD13
PDL14	119	143			AD14
PDL15	120	144			AD15

**Remark** SJ3-H: V850E/SJ3-H

SK3-H: V850E/SK3-H

GJ (V850E/SJ3-H): 144-pin plastic LQFP (fine pitch) (20 × 20)

GM (V850E/SK3-H): 176-pin plastic LQFP (fine pitch) (24 × 24)

(2) Non-port pins

(1/10)

Pin Name	Pin No.		I/O	Function	Alternate Function
	SJ3-H	SK3-H			
	GJ	GM			
A0	61	77	Output	Address bus for external memory (when using separate bus) Port 9 cannot be used as port pins or other alternate-function pins when the A0 to A15 pins are used in the separate bus mode. N-ch open-drain output selectable 5 V tolerant.	P90/KR6/TXDA1/SDA02
A1	62	78			P91/KR7/RXDA1/KR7/SCL02
A2	63	79			P92/TIP41/TOP41
A3	64	80			P93/TIP40/TOP40/INTP8
A4	65	81			P94/TIP31 /TOP31
A5	66	82			P95/TIP30/TOP30/INTP5
A6	67	83			P96/TIP21/TOP21
A7	68	84			P97/SIB1/TIP20/TOP20
A8	69	85			P98/SOB1
A9	70	86			P99/SCKB1
A10	71	87			P910/SIB3
A11	72	88			P911/SOB3
A12	73	89			P912/SCKB3
A13	74	90			P913/INTP4
A14	75	91			P914/INTP5/TIP51/TOP51
A15	76	92	P915/INTP6/TIP50/TOP50		
A16	121	145	Output	Address bus for external memory	PDH0
A17	122	146			PDH1
A18	123	147			PDH2
A19	124	148			PDH3
A20	125	149			PDH4
A21	126	150			PDH5
A22	127	151			PDH6
A23	128	152			PDH7

**Remark** SJ3-H: V850E/SJ3-H  
 SK3-H: V850E/SK3-H  
 GJ (V850E/SJ3-H): 144-pin plastic LQFP (fine pitch) (20 × 20)  
 GM (V850E/SK3-H): 176-pin plastic LQFP (fine pitch) (24 × 24)

(2/10)

Pin Name	Pin No.		I/O	Function	Alternate Function
	SJ3-H	SK3-H			
	GJ	GM			
AD0	105	129	I/O	Address/data bus for external memory	PDL0
AD1	106	130			PDL1
AD2	107	131			PDL2
AD3	108	132			PDL3
AD4	109	133			PDL4
AD5	110	134			PDL5/FLMD1
AD6	111	135			PDL6
AD7	112	136			PDL7
AD8	113	137			PDL8
AD9	114	138			PDL9
AD10	115	139			PDL10
AD11	116	140			PDL11
AD12	117	141			PDL12
AD13	118	142			PDL13
AD14	119	143			PDL14
AD15	120	144			PDL15
ADTRG	18	20	Input	A/D converter external trigger input, 5 V tolerant	P03/INTP0
ANI0	144	176	Input	Analog voltage input for A/D converter	P70
ANI1	143	175			P71
ANI2	142	174			P72
ANI3	141	173			P73
ANI4	140	172			P74
ANI5	139	171			P75
ANI6	138	170			P76
ANI7	137	169			P77
ANI8	136	168			P78
ANI9	135	167			P79
ANI10	134	166			P710
ANI11	133	165			P711
ANI12	132	164			P712
ANI13	131	163			P713
ANI14	130	162			P714
ANI15	129	161			P715
ANO0	3	3	Output	Analog voltage output for D/A converter	P10
ANO1	4	4			P11
ASCKA0	27	32	Input	UARTA0 baud rate clock input, 5 V tolerant	P32/SCKB4/TIP00/TOP00
ASTB	101	121	Output	Address strobe signal output for external memory	PCT6

**Remark** SJ3-H: V850E/SJ3-H  
SK3-H: V850E/SK3-H  
GJ (V850E/SJ3-H): 144-pin plastic LQFP (fine pitch) (20 × 20)  
GM (V850E/SK3-H): 176-pin plastic LQFP (fine pitch) (24 × 24)

Pin Name	Pin No.		I/O	Function	Alternate Function
	SJ3-H	SK3-H			
	GJ	GM			
AV <sub>REF0</sub>	1	1	–	Reference voltage input for A/D converter, positive power supply for port 7	–
AV <sub>REF1</sub>	5	5	–	Reference voltage input for D/A converter, positive power supply for port 1	–
AV <sub>SS</sub>	2	2	–	Ground potential for A/D and D/A converters (same potential as V <sub>SS</sub> )	–
BV <sub>DD</sub>	104	124	–	Positive power supply for bus interface and alternate-function ports	–
	–	153			–
BV <sub>SS</sub>	103	123	–	Ground potential for bus interface and alternate-function ports	–
	–	154			–
CLKOUT	86	106	Output	Internal system clock output	PCM1
CRXD0 <sup>Note 1</sup>	32	37	Input	CAN0, CAN1 receive data input 5 V tolerant	P37/I <sub>ERX0</sub>
CRXD1 <sup>Note 2</sup>	29	34			P34/TIP10/TOP10
$\overline{CS1}$	82	102	Output	Chip select output	PCS1
$\overline{CS2}$	83	103			PCS2
$\overline{CS3}$	84	104			PCS3
CTXD0 <sup>Note 1</sup>	31	36	Output	CAN0, CAN1 transmit data output N-ch open-drain output selectable, 5 V tolerant	P36/I <sub>ETX0</sub>
CTXD1 <sup>Note 2</sup>	28	33			P33/TIP01/TOP01
DCK	41	49	Input	Debug clock input, 5 V tolerant	P54/SOB2/KR4/RTP04
DDI	39	47	Input	Debug data input, 5 V tolerant	P52/KR2/TIQ03/TOQ03/RTP02
DDO <sup>Note 3</sup>	40	48	Output	Debug data output N-ch open-drain output selectable, 5 V tolerant	P53/SIB2/KR3/TIQ00/TOQ00/RTP03
DMS	42	50	Input	Debug mode select input, 5 V tolerant	P55/S <sub>CKB2</sub> /KR5/RTP05
$\overline{DRST}$	20	22	Input	Debug reset input, 5 V tolerant	P05/INTP2
EV <sub>DD</sub>	34	39	–	Positive power supply for external (same potential as V <sub>DD</sub> )	–
	–	69			–
EV <sub>SS</sub>	33	38	–	Ground potential for external (same potential as V <sub>SS</sub> )	–
	–	70			–
FLMD0	8	10	Input	Flash memory programming mode setting pin	–
FLMD1	110	134			PDL5/AD5
$\overline{HLDAK}$	87	107	Output	Bus hold acknowledge output	PCM2
$\overline{HLDRQ}$	88	108	Input	Bus hold request input	PCM3
$\overline{IERX0}$	–	29	Input	IEBus receive data input, 5 V tolerant	P45 <sup>Note 4</sup>
	32	37			P37/CRXD0 <sup>Note 1</sup>
$\overline{IETX0}$	–	28	Output	IEBus transmit data output N-ch open-drain output selectable, 5 V tolerant	P44 <sup>Note 4</sup>
	31	36			P36/CTXD0 <sup>Note 1</sup>

- Notes**
1. CAN controller version only
  2. CAN controller (2-channel) version only
  3. In the on-chip debug mode, high-level output is forcibly set.
  4. V850E/SK3-H only

**Remark** SJ3-H: V850E/SJ3-H  
SK3-H: V850E/SK3-H  
GJ (V850E/SJ3-H): 144-pin plastic LQFP (fine pitch) (20 × 20)  
GM (V850E/SK3-H): 176-pin plastic LQFP (fine pitch) (24 × 24)

Pin Name	Pin No.		I/O	Function	Alternate Function
	SJ3-H	SK3-H			
	GJ	GM			
INTP0	18	20	Input	External interrupt request input (maskable, analog noise elimination). Analog noise elimination/digital noise elimination selectable for the INTP3 pin. 5 V tolerant	P03/ADTRG
INTP1	19	21			P04
INTP2	20	22			P05/DRST
	24	26			P42/SCKB0
INTP3	21	23			P06
INTP4	74	90			P913/A13
INTP5	66	82			P95/A5/TIP30/TOP30
	75	91			P914/A14/TIP51/TOP51
INTP6	–	96			P153 <sup>Note 1</sup>
	76	92			P915/A15/TIP50/TOP50
INTP7	26	31			P31/RXDA0/SIB4
	38	46			P51/KR1/TIQ02/TOQ02/RTP01
INTP8 <sup>Note 2</sup>	59	71			P80/RXDA3/RC1CK1HZ
	64	80			P93/A3/TIP40/TOP40
INTP9	49	59			P66/SIB5/KR3/TIQ00/TOQ00
	–	95	P152 <sup>Note 1</sup>		
KR0 <sup>Notes 3, 4</sup>	37	45	Input	Key interrupt input (on-chip analog noise eliminator) 5 V tolerant	P50/TIQ01/TOQ01/RTP00
KR1 <sup>Notes 3, 5</sup>	38	46			P51/INTP7/TIQ02/TOQ02/RTP01
KR2 <sup>Notes 3, 6</sup>	39	47			P52/TIQ03/TOQ03/RTP02/DDI
	48	58			P65/RTP15/SCKET <sup>Note 9</sup> /TIQ03/TOQ03
KR3 <sup>Notes 3, 7</sup>	40	48			P53/SIB2/TIQ00/TOQ00/RTP03/DDO
	49	59	P66/SIB5/INTP9/TIQ00/TOQ00		

**Notes 1.** V850E/SK3-H only

- To use the RXDA3 pin and INTP8 pin at the same time, use the RXDA3 pin at Pin 59 and the INTP8 pin at Pin 64 for the V850E/SJ3-H, and use the RXDA3 pin at Pin 71 and the INTP8 pin at Pin 80 for the V850E/SK3-H. In addition, when using the RXDA3 pin, always invalidate the edge detection function of the INTP8 pin at Pin 59 (V850E/SJ3-H) and Pin 71 (V850E/SK3-H).
- Pull this pin up externally.
- Invalidate the edge detection function of the TIQ01 pin when using the KR0 pin.
- Invalidate the edge detection function of the TIQ02 pin when using the KR1 pin.
- Invalidate the edge detection function of the TIQ03 pin when using the KR2 pin.  
Although the KR2 and TIQ03 pins are assigned to two ports each, the pins cannot be used at the same time at different ports.
- Invalidate the edge detection function of the TIQ00 pin when using the KR3 pin.  
Although the KR3 and TIQ00 pins are assigned to two ports each, the pins cannot be used at the same time at different ports.
- Not available in the  $\mu$ PD70F3931 (V850E/SJ3-H), 70F3932 (V850E/SJ3-H), and 70F3933 (V850E/SJ3-H)

**Remark** SJ3-H: V850E/SJ3-H

SK3-H: V850E/SK3-H

GJ (V850E/SJ3-H): 144-pin plastic LQFP (fine pitch) (20 × 20)

GM (V850E/SK3-H): 176-pin plastic LQFP (fine pitch) (24 × 24)

	Pin Name	Pin No.		I/O	Function	Alternate Function
		SJ3-H	SK3-H			
		GJ	GM			
<R>	KR4 <sup>Note 1</sup>	41	49	Input	Key interrupt input (on-chip analog noise eliminator) 5 V tolerant	P54/SOB2/RTP04/DCK
		46	56			P63/RTP13/SIE1 <sup>Note 4</sup>
<R>	KR5 <sup>Note 1</sup>	42	50			P55/SCKB2/RTP05/DMS
		47	57			P64/RTP14/SOE1 <sup>Note 4</sup>
	KR6 <sup>Note 1</sup>	61	77			P90/A0/TXDA1/SDA02
	KR7 <sup>Notes 1,2</sup>	62	78			P91/A1/RXDA1/KR7/SCL02
		–	93			P150 <sup>Note 5</sup> /RXDA1 <sup>Note 5</sup>
	NMI <sup>Note 3</sup>	17	19	Input	External interrupt input (non-maskable, analog noise elimination) 5 V tolerant	P02
	RC1CK1HZ	59	71	Output	Real-time counter correction clock (1 Hz) output N-ch open-drain output selectable 5 V tolerant	P80/RXDA3/INTP8
	RC1CKDIV	60	72	Output	Real-time counter clock (32 kHz division) output N-ch open-drain output selectable 5 V tolerant	P81/TXDA3/RC1CKO
	RC1CKO	60	72	Output	Real-time counter clock (32 kHz primary oscillation) output N-ch open-drain output selectable 5 V tolerant	P81/TXDA3/RC1CKDIV
	RD	99	119	Output	Read strobe signal output for external memory	PCT4
	REGC	10	12	–	Connection of regulator output stabilization capacitance (4.7 $\mu$ F)	–
	RESET	14	16	Input	System reset input	–
	RTP00	37	45	Output	Real-time output port N-ch open-drain output selectable 5 V tolerant	P50/KR0/TIQ01/TOQ01
	RTP01	38	46			P51/INTP7/KR1/TIQ02/TOQ02
	RTP02	39	47			P52/KR2/TIQ03/TOQ03/DDI
	RTP03	40	48			P53/SIB2/KR3/TIQ00/TOQ00/DDO
	RTP04	41	49			P54/SOB2/KR4/DCK
	RTP05	42	50			P55/SCKB2/KR5/DMS
<R>	RTP10	43	53			P60/RXDA4/SIE0 <sup>Note 4</sup>
<R>	RTP11	44	54			P61/TXDA4/SOE0 <sup>Note 4</sup>
<R>	RTP12	45	55			P62/SCKE0 <sup>Note 4</sup>
<R>	RTP13	46	56			P63/SIE1 <sup>Note 4</sup> /KR4
<R>	RTP14	47	57			P64/SOE1 <sup>Note 4</sup> /KR5
<R>	RTP15	48	58			P65/SCKE1 <sup>Note 4</sup> /KR2/TIQ03/TOQ03

**Notes 1.** Pull this pin up externally.

**2.** Disable the reception operation of UARTA1 when using the KR7 pin. Although the KR7 and RXDA1 pins are assigned to two ports each, the pins cannot be used at the same time at different ports in the V850E/SK3-H.

**3.** The NMI pin alternately functions as the P02 pin. It functions as P02 pin after reset. To enable the NMI pin, set the PMC0.PMC02 bit to 1. The initial setting of the NMI pin is “No edge detected”. Select the NMI pin valid edge using INTF0 and INTR0 registers.

<R> **4.** Not available in the  $\mu$ PD70F3931 (V850E/SJ3-H), 70F3932 (V850E/SJ3-H), and 70F3933 (V850E/SJ3-H)

**5.** V850E/SK3-H only

**Remark** SJ3-H: V850E/SJ3-H

SK3-H: V850E/SK3-H

GJ (V850E/SJ3-H): 144-pin plastic LQFP (fine pitch) (20  $\times$  20)

GM (V850E/SK3-H): 176-pin plastic LQFP (fine pitch) (24  $\times$  24)



Pin Name	Pin No.		I/O	Function	Alternate Function
	SJ3-H	SK3-H			
	GJ	GM			
RXDA0	26	31	Input	Serial receive data input (UARTA0 to UARTA5) 5 V tolerant	P31/INTP7/SIB4
RXDA1 <sup>Note 1</sup>	62	78			P91/A1/KR7/KR7/SCL02
	–	93			P150 <sup>Note 4</sup> /KR7 <sup>Note 4</sup>
RXDA2	36	41			P39/SCL00/SCKB2
	–	44			P312 <sup>Note 4</sup>
RXDA3 <sup>Note 2</sup>	59	71			P80/INTP8/RC1CK1HZ
RXDA4	–	51			P56 <sup>Note 4</sup>
	43	53			P60/RTP10/SIE0 <sup>Note 3</sup>
RXDA5	50	60			P67/SOB5/SDA05 <sup>Note 3</sup>
	–	75			P84 <sup>Note 4</sup>
RXDB0	77	97	Input	Serial receive data input (UARTB0, UARTB1)	PCD0
RXDB1	79	99			PCD2
SCKB0	24	26	I/O	Serial clock I/O (CSIB0 to CSIB5) N-ch open-drain output selectable 5 V tolerant	P42/INTP2
SCKB1	70	86			P99/A9
SCKB2	36	41			P39/RXDA2/SCL00
	42	50			P55/KR5/RTP05/DMS
SCKB3	73	89			P912/A12
SCKB4	27	32			P32/ASCKA0/TIP00/TOP00
SCKB5	51	61			P68/TXDA5/SCL05 <sup>Note 3</sup>
SCKE0 <sup>Note 3</sup>	45	55	I/O	Serial clock I/O (CSIE0, CSIE1) N-ch open-drain output selectable 5 V tolerant	P62/RTP12
SCKE1 <sup>Note 3</sup>	48	58			P65/RTP15/KR2/TIQ03/TOQ03
SCL00	36	41	I/O	Serial clock I/O (I <sup>2</sup> C00 to I <sup>2</sup> C05) N-ch open-drain output selectable 5 V tolerant	P39/RXDA2/SCKB2
SCL01	23	25			P41/SOB0
SCL02	62	78			P91/A1/KR7/RXDA1/KR7
SCL03	58	68			P615
SCL04 <sup>Note 3</sup>	7	7			P01/TIP60/TOP60
	–	9	P21 <sup>Note 4</sup>		

**Notes 1.** Invalidate the key return signal detection function of the KR7 pin when using the RXDA1 pin. Although the RXDA1 and KR7 pins are assigned to two ports each, the pins cannot be used at the same time at different ports in the V850E/SK3-H.

**2.** When using the RXDA3 pin, always invalidate the edge detection function of the INTP8 pin at Pin 59 (V850E/SJ3-H) and Pin 71 (V850E/SK3-H). In this case, use the INTP8 pin at Pin 64 (V850E/SJ3-H) or Pin 80 (V850E/SK3-H).

**3.** Not available in the  $\mu$ PD70F3931 (V850E/SJ3-H), 70F3932 (V850E/SJ3-H), and 70F3933 (V850E/SJ3-H)

**4.** V850E/SK3-H only

**Remark** SJ3-H: V850E/SJ3-H

SK3-H: V850E/SK3-H

GJ (V850E/SJ3-H): 144-pin plastic LQFP (fine pitch) (20 × 20)

GM (V850E/SK3-H): 176-pin plastic LQFP (fine pitch) (24 × 24)

	Pin Name	Pin No.		I/O	Function	Alternate Function		
		SJ3-H	SK3-H					
		GJ	GM					
<R>	SCL05 <sup>Note 1</sup>	51	61	I/O	Serial clock I/O (I <sup>2</sup> C00 to I <sup>2</sup> C05) N-ch open-drain output selectable 5 V tolerant	P68/SCKB5/TXDA5		
		–	74			P83 <sup>Note 2</sup>		
	SDA00	35	40	I/O	Serial transmit/receive data I/O (I <sup>2</sup> C00 to I <sup>2</sup> C05) N-ch open-drain output selectable 5 V tolerant	P38/TXDA2/SIB2		
	SDA01	22	24			P40/SIB0		
	SDA02	61	77			P90/A0/KR6/TXDA1		
	SDA03	57	67			P614/TECR8		
<R>	SDA04 <sup>Note 1</sup>	6	6			P00/TIP61/TOP61		
		–	8			P20 <sup>Note 2</sup>		
<R>	SDA05 <sup>Note 1</sup>	50	60			P67/SOB5/RXDA5		
		–	73			P82 <sup>Note 2</sup>		
	SIB0	22	24			Input	Serial receive data input (CSIB0 to CSIB5) 5 V tolerant	P40/SDA01
	SIB1	68	84					P97/A7/TIP20/TOP20
	SIB2	35	40	P38/TXDA2/SDA00				
		40	48	P53/KR3/TIQ00/TOQ00/RTP03/DDO				
	SIB3	71	87	P910/A10				
	SIB4	26	31	P31/RXDA0/INTP7				
	SIB5	49	59	P66/INTP9/KR3/TIQ00/TOQ00				
<R>	SIE0 <sup>Note 1</sup>	43	53	Input	Serial receive data input (CSIE0, CSIE1) 5 V tolerant	P60/RTP10/RXDA4		
<R>	SIE1 <sup>Note 1</sup>	46	56			P63/RTP13/KR4		
	SOB0	23	25	Output	Serial transmit data output (CSIB0 to CSIB5) N-ch open-drain output selectable 5 V tolerant	P41/SCL01		
	SOB1	69	85			P98/A8		
	SOB2	–	42			P310 <sup>Note 2</sup>		
		41	49			P54/KR4/RTP04/DCK		
	SOB3	72	88			P911/A11		
	SOB4	25	30			P30/TXDA0		
<R>	SOB5	50	60			P67/RXDA5/SDA05 <sup>Note 1</sup>		
<R>	SOE0 <sup>Note 1</sup>	44	54	Output	Serial transmit data output (CSIE0, CSIE1) N-ch open-drain output selectable 5 V tolerant	P61/RTP11/TXDA4		
<R>	SOE1 <sup>Note 1</sup>	47	57			P64/RTP14/KR5		
	TECR7	54	64	Input	Encoder clear input (TMP7, TMP8) 5 V tolerant	P611/TOP71		
	TECR8	57	67			P614/SDA03		
	TENC70	52	62	Input	Encoder input (TMP7, TMP8) 5 V tolerant	P69/TIP70/TOP70		
	TENC71	53	63			P610/TIP71		
	TENC80	55	65			P612/TIP80/TOP80		
	TENC81	56	66			P613/TIP81/TOP81		

<R> **Notes 1.** Not available in the  $\mu$ PD70F3931 (V850E/SJ3-H), 70F3932 (V850E/SJ3-H), and 70F3933 (V850E/SJ3-H)

**2.** V850E/SK3-H only

**Remark** SJ3-H: V850E/SJ3-H

SK3-H: V850E/SK3-H

GJ (V850E/SJ3-H): 144-pin plastic LQFP (fine pitch) (20 × 20)

GM (V850E/SK3-H): 176-pin plastic LQFP (fine pitch) (24 × 24)

Pin Name	Pin No.		I/O	Function	Alternate Function
	SJ3-H	SK3-H			
	GJ	GM			
TIP00	27	32	Input	External event count input/capture trigger input/external trigger input (TMP0) 5 V tolerant	P32/ASCKA0/SCKB4/TOP00
TIP01	28	33		Capture trigger input (TMP0) 5V tolerant	P33/TOP01/CTXD1 <sup>Note 1</sup>
TIP10	29	34		External event count input/capture trigger input/external trigger input (TMP1) 5 V tolerant	P34/TOP10/CRXD1 <sup>Note 1</sup>
TIP11	30	35		Capture trigger input (TMP1) 5V tolerant	P35/TOP11
TIP20	68	84		External event count input/capture trigger input/external trigger input (TMP2) 5 V tolerant	P97/A7/SIB1/TOP20
TIP21	67	83		Capture trigger input (TMP2) 5 V tolerant	P96/A6/TOP21
TIP30	66	82		External event count input/capture trigger input/external trigger input (TMP3) 5 V tolerant	P95/A5/TOP30/INTP5
TIP31	65	81		Capture trigger input (TMP3) 5V tolerant	P94/A4/TOP31
TIP40	64	80		External event count input/capture trigger input/external trigger input (TMP4) 5V tolerant	P93/A3/TOP40/INTP8
TIP41	63	79		Capture trigger input (TMP4) 5V tolerant	P92/A2/TOP41
TIP50	76	92		External event count input/capture trigger input/external trigger input (TMP5) 5 V tolerant	P915/A15/INTP6/TOP50
TIP51	75	91		Capture trigger input (TMP5) 5V tolerant	P914/A14/INTP5/TOP51
<R> TIP60	7	7		External event count input/capture trigger input/external trigger input (TMP6) 5 V tolerant	P01/TOP60/SCL04 <sup>Note 2</sup>
<R> TIP61	6	6		Capture trigger input (TMP6) 5V tolerant	P00/TOP61/SDA04 <sup>Note 2</sup>

**Notes 1.** CAN controller (2-channel) version only

<R> **2.** Not available in the  $\mu$ PD70F3931 (V850E/SJ3-H), 70F3932 (V850E/SJ3-H), and 70F3933 (V850E/SJ3-H)

**Remark** SJ3-H: V850E/SJ3-H

SK3-H: V850E/SK3-H

GJ (V850E/SJ3-H): 144-pin plastic LQFP (fine pitch) (20 × 20)

GM (V850E/SK3-H): 176-pin plastic LQFP (fine pitch) (24 × 24)

Pin Name	Pin No.		I/O	Function	Alternate Function	
	SJ3-H	SK3-H				
	GJ	GM				
TIP70	52	62	Input	External event count input/capture trigger input/external trigger input (TMP7) 5 V tolerant	P69/TOP70/TENC70	
TIP71	53	63		Capture trigger input (TMP7) 5V tolerant	P610/TENC71	
TIP80	55	65		External event count input/capture trigger input/external trigger input (TMP8) 5 V tolerant	P612/TOP80/TENC80	
TIP81	56	66		Capture trigger input (TMP8) 5V tolerant	P613/TOP81/TENC81	
TIQ00 <sup>Note 1</sup>	40	48	Input	External event count input/capture trigger input/external trigger input (TMQ0) 5V tolerant	P53/SIB2/KR3/TOQ00/RTP03/DDO	
	49	59			P66/SIB5/INTP9/KR3/TOQ00	
TIQ01 <sup>Note 2</sup>	37	45		Capture trigger input (TMQ0) 5V tolerant	P50/KR0/TOQ01/RTP00	
TIQ02 <sup>Note 3</sup>	38	46		P51/INTP7/KR1/TOQ02/RTP01		
TIQ03 <sup>Note 4</sup>	39	47			P52/KR2/TOQ03/RTP02/DD1	
	48	58			P65/RTP15/SCKE1/ <sup>Note 5</sup> KR2/TOQ03	
TOP00	27	32		Output	Timer output (TMP0) N-ch open-drain output selectable, 5 V tolerant	P32/ASCKA0/SCKB4/TIP00
TOP01	28	33			P33/TIP01/CTXD1 <sup>Note 6</sup>	
TOP10	29	34	Timer output (TMP1) N-ch open-drain output selectable, 5 V tolerant		P34/TIP10/CRXD1 <sup>Note 6</sup>	
TOP11	30	35	P35/TIP11			
TOP20	68	84	Timer output (TMP2) N-ch open-drain output selectable, 5 V tolerant		P97/A7/SIB1/TIP20	
TOP21	67	83	P96/A6/TIP21			
TOP30	66	82	Timer output (TMP3) N-ch open-drain output selectable, 5 V tolerant		P95/A5/TIP30/INTP5	
TOP31	65	81	P94/A4/TIP31			
TOP40	64	80	Timer output (TMP4) N-ch open-drain output selectable, 5 V tolerant		P93/A3/TIP40/INTP8	
TOP41	63	79	P92/A2/TIP41			

**Notes 1.** Invalidate the key return signal detection function of the KR3 pin when using the TIQ00 pin. Although the TIQ00 and KR3 pins are assigned to two ports each, the pins cannot be used at the same time at different ports.

**2.** Invalidate the key return signal detection function of the KR0 pin when using the TIQ01 pin.

**3.** Invalidate the key return signal detection function of the KR1 pin when using the TIQ02 pin.

**4.** Invalidate the key return signal detection function of the KR2 pin when using the TIQ03 pin.

Although the TIQ03 and KR2 pins are assigned to two ports each, the pins cannot be used at the same time at different ports.

**5.** Not available in the  $\mu$ PD70F3931 (V850E/SJ3-H), 70F3932 (V850E/SJ3-H), and 70F3933 (V850E/SJ3-H)

**6.** CAN controller (2-channel) version only

**Remark** SJ3-H: V850E/SJ3-H

SK3-H: V850E/SK3-H

GJ (V850E/SJ3-H): 144-pin plastic LQFP (fine pitch) (20 × 20)

GM (V850E/SK3-H): 176-pin plastic LQFP (fine pitch) (24 × 24)

Pin Name	Pin No.		I/O	Function	Alternate Function
	SJ3-H	SK3-H			
	GJ	GM			
TOP50	76	92	Output	Timer output (TMP5) N-ch open-drain output selectable, 5 V tolerant	P915/A15/INTP6/TIP50
TOP51	75	91			P914/A14/INTP5/TIP51
TOP60	7	7	Output	Timer output (TMP6) N-ch open-drain output selectable, 5 V tolerant	P01/TIP60/SCL04 <sup>Note 1</sup>
TOP61	6	6			P00/TIP61/SDA04 <sup>Note 1</sup>
TOP70	52	62		Timer output (TMP7) N-ch open-drain output selectable, 5 V tolerant	P69/TIP70/TENC70
TOP71	54	64			P611/TECR7
TOP80	55	65		Timer output (TMP8) N-ch open-drain output selectable, 5 V tolerant	P612/TIP80/TENC80
TOP81	56	66			P613/TIP81/TENC81
TOQ00	40	48		Output	Timer output (TMQ0) N-ch open-drain output selectable, 5 V tolerant
	49	59	P66/SIB5/INTP9/KR3/TIQ00		
TOQ01	37	45	P50/KR0/TIQ01/RTP00		
TOQ02	38	46	P51/INTP7/KR1/TIQ02/RTP01		
TOQ03	39	47	P52/KR2/TIQ03/RTP02/DDI		
	48	58	P65/RTP15/SCKE1 <sup>Note 1</sup> /KR2/TIQ03		
TXDA0	25	30	Output		
TXDA1	61	77		P90/A0/KR6/SDA02	
	–	94		P151 <sup>Note 2</sup>	
TXDA2	35	40		P38/SDA00/SIB2	
	–	43		P311 <sup>Note 2</sup>	
TXDA3	60	72		P81/RC1CKO/RC1CKDIV	
TXDA4	–	52		P57 <sup>Note 2</sup>	
	44	54		P61/RTP11/SOE0 <sup>Note 1</sup>	
TXDA5	51	61		P68/SCKB5/SCL05 <sup>Note 1</sup>	
	–	76		P85 <sup>Note 2</sup>	
TXDB0	78	98	Output	Serial transmit data output (UARTB0, UARTB1)	PCD1
TXDB1	80	100			PCD3
V <sub>DD</sub>	9	11	–	Positive power supply pin for internal	–
V <sub>SS</sub>	11	13	–	Ground potential for internal	–
WAIT	85	105	Input	External wait input	PCM0
WR <sub>0</sub>	95	115	Output	Write strobe for external memory (lower 8 bits)	PCT0
WR <sub>1</sub>	96	116		Write strobe for external memory (higher 8 bits)	PCT1
X1	12	14	Input	Connection of resonator for main clock	–
X2	13	15	–		–
XT1	15	17	Input	Connection of resonator for subclock	–
XT2	16	18	–		–

**Notes 1.** Not available in the  $\mu$ PD70F3931 (V850E/SJ3-H), 70F3932 (V850E/SJ3-H), and 70F3933 (V850E/SJ3-H)

**2.** V850E/SK3-H only

**Remark** SJ3-H: V850E/SJ3-H

SK3-H: V850E/SK3-H

GJ (V850E/SJ3-H): 144-pin plastic LQFP (fine pitch) (20 × 20)

GM (V850E/SK3-H): 176-pin plastic LQFP (fine pitch) (24 × 24)

## 2.2 Port Sharing of Alternate Functions

The V850E/SJ3-H and V850E/SK3-H have the same alternate functions that are assigned to two ports. Which port is used for the alternate function can be selected at the port setup.

**Caution** When using an alternate function that is assigned to two ports, always use the alternate function at only one of the ports.

Table 2-2. Port Sharing of Alternate Functions (1/2)

(a) V850E/SJ3-H

Function	Alternate Function	I/O	Port <1>		Port <2>	
			Pin No.	Port Function	Pin No.	Port Function
External interrupt	INTP2	Input	20	P05	24	P42
	INTP5		75	P914	66	P95
	INTP7		26	P31	38	P51
	INTP8		59	P80	64	P93
CSIB2	SIB2	Input	40	P53	35	P38
	SCKB2	I/O	42	P55	36	P39
Key interrupt	KR4	Input	41	P54	46	P63
	KR5		42	P55	47	P64
TMQ0 (/KR2, /KR3)	TIQ00/KR3 <sup>Note 1</sup>	Input	40	P53	49	P66
	TOQ00	Output	40	P53	49	P66
	TIQ03/KR2 <sup>Note 2</sup>	Input	39	P52	48	P65
	TOQ03	Output	39	P52	48	P65

- Notes 1.** Although the TIQ00 and KR3 pins are assigned to two ports each, the pins cannot be used at the same time at different ports.
- 2.** Although the TIQ03 and KR2 pins are assigned to two ports each, the pins cannot be used at the same time at different ports.

Table 2-2. Port Sharing of Alternate Functions (2/2)

## (b) V850E/SK3-H

Function	Alternate Function	I/O	Port <1>		Port <2>	
			Pin No.	Port Function	Pin No.	Port Function
External interrupt	INTP2	Input	22	P05	26	P42
	INTP5		91	P914	82	P95
	INTP6		92	P915	96	P153
	INTP7		31	P31	46	P51
	INTP8		71	P80	80	P93
	INTP9		59	P66	95	P152
I <sup>2</sup> C04	SCL04	I/O	7	P01	9	P21
	SDA04		6	P00	8	P20
I <sup>2</sup> C05	SCL05		61	P68	74	P83
	SDA05		60	P67	73	P82
CSIB2	SIB2	Input	48	P53	40	P38
	SOB2	Output	49	P54	42	P310
	$\overline{\text{SCKB2}}$	I/O	50	P55	41	P39
UARTA1 (/KR7)	RXDA1/KR7 <sup>Note 1</sup>	Input	78	P91	93	P150
	TXDA1	Output	77	P90	94	P151
UARTA2	RXDA2	Input	41	P39	44	P312
	TXDA2	Output	40	P38	43	P311
UARTA4	RXDA4	Input	53	P60	51	P56
	TXDA4	Output	54	P61	52	P57
UARTA5	RXDA5	Input	60	P67	75	P84
	TXDA5	Output	61	P68	76	P85
IEBus	$\overline{\text{IERX0}}$	Input	37	P37	29	P45
	$\overline{\text{IETX0}}$	Output	36	P36	28	P44
Key interrupt	KR4	Input	49	P54	56	P63
	KR5		50	P55	57	P64
TMQ0 (/KR2, /KR3)	TIQ00/KR3 <sup>Note 2</sup>	Input	48	P53	59	P66
	TOQ00	Output	48	P53	59	P66
	TIQ03/KR2 <sup>Note 3</sup>	Input	47	P52	58	P65
	TOQ03	Output	47	P52	58	P65

**Notes 1.** Although the RXDA1 and KR7 pins are assigned to two ports each, the pins cannot be used at the same time at different ports.

**2.** Although the TIQ00 and KR3 pins are assigned to two ports each, the pins cannot be used at the same time at different ports.

**3.** Although the TIQ03 and KR2 pins are assigned to two ports each, the pins cannot be used at the same time at different ports.



The following shows a port sharing assignment diagram of alternate functions.

**Figure 2-1. Alternate-Function Port Sharing Assignment Diagram for V850E/SJ3-H (144-Pin Plastic LQFP (Fine Pitch) (20 × 20))**

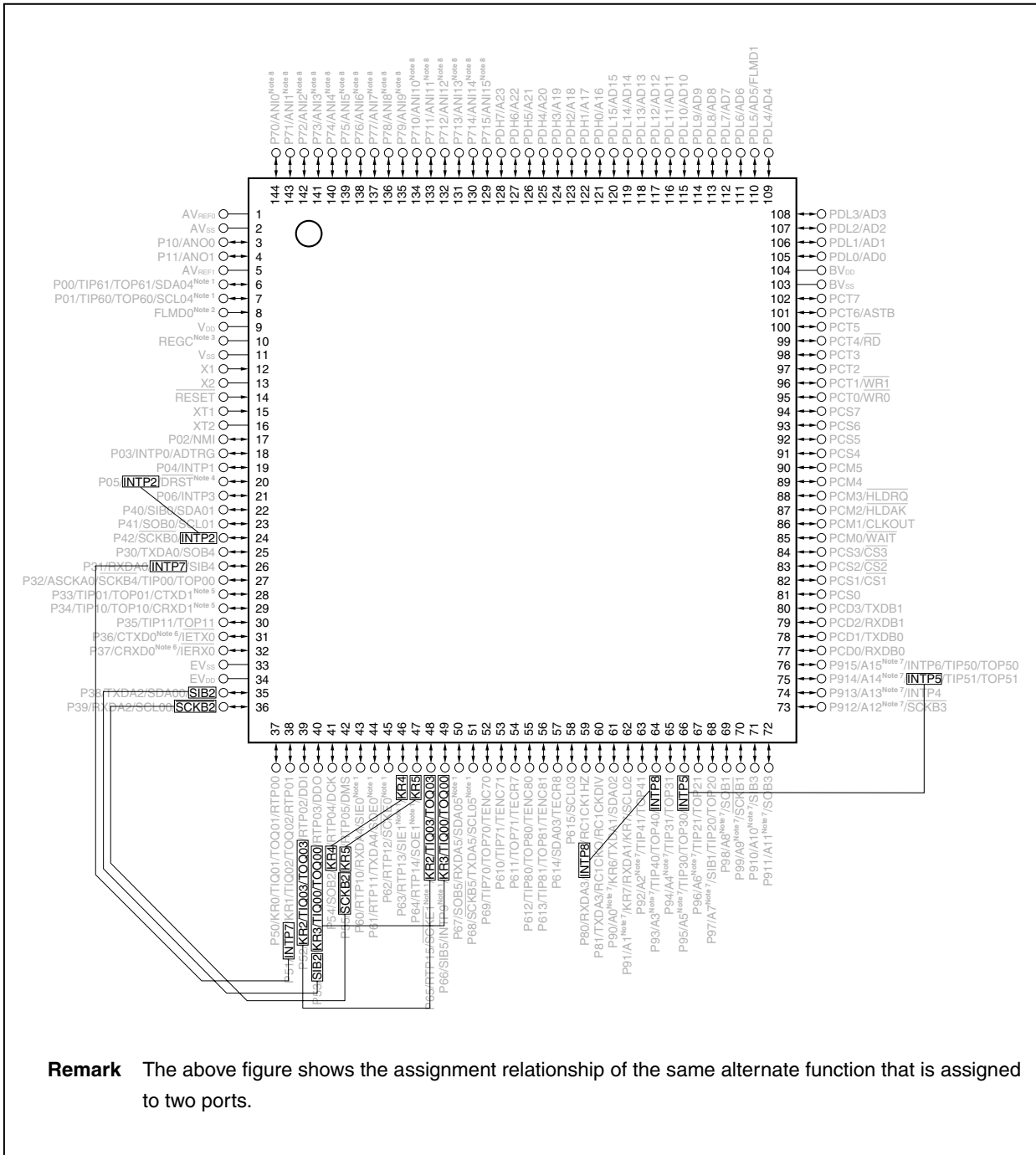
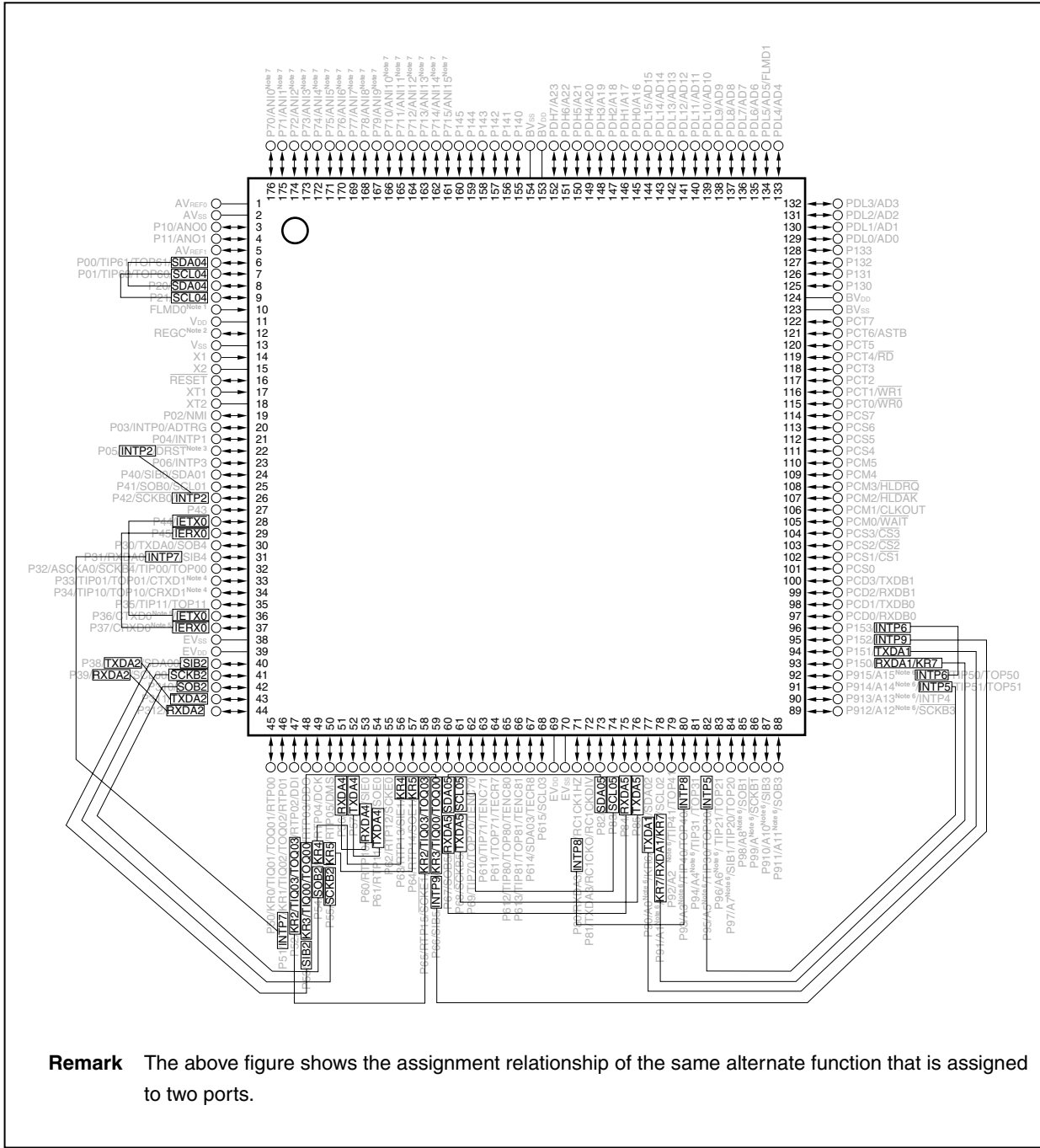

Figure 2-2 Alternate-Function Port Sharing Assignment Diagram for V850E/SK3-H  
(176-Pin Plastic LQFP (Fine Pitch) (24 × 24))



## 2.3 Pin States

The operation states of pins in the various operation modes are described below.

**Table 2-3. Pin Operation States in Various Modes**

Pin Name	During Reset (Immediately After Power Is Turned On)	During Reset (Except Immediately After Power Is Turned On)	HALT Mode <sup>Note 2</sup>	IDLE1, IDLE2, Sub-IDLE Mode <sup>Note 2</sup>	STOP Mode <sup>Note 2</sup>	Idle State <sup>Note 3</sup>	Bus Hold					
P05/ $\overline{DRST}$	Pull down	Pull down <sup>Note 4</sup>	Held	Held	Held	Held	Held					
P10/ANO0, P11/ANO1	Hi-Z	Hi-Z	Held	Held	<b>Note 10</b>	Held	Held					
P53/DDO	Undefined <sup>Note 1</sup>	Hi-Z <sup>Note 5</sup>	Held	Held	Held	Held	Held					
AD0 to AD15	Hi-Z <sup>Note 6</sup>	Hi-Z <sup>Note 6</sup>	<b>Notes 7, 8</b>	Hi-Z	Hi-Z	Held	Hi-Z					
A0 to A15			Undefined <sup>Notes 7,9</sup>									
A16 to A23			Undefined <sup>Note 7</sup>									
$\overline{WAIT}$			–									
CLKOUT			Operating					L	L	Operating	Operating	
$\overline{WR0}$ , $\overline{WR1}$			H <sup>Note 7</sup>					H	H	H	H	Hi-Z
$\overline{RD}$												
ASTB												
$\overline{HLDAK}$												
$\overline{HLDRQ}$			Operating <sup>Note 7</sup>					–	–	–	–	L
$\overline{CS1}$ to $\overline{CS3}$			H <sup>Note 7</sup>					H	H	H	H	Hi-Z
Other port pins			Hi-Z					Hi-Z	Held	Held	Held	Held

**Notes 1.** These pins may momentarily output an undefined level upon power application.

**2.** Operates while alternate functions are operating.

**3.** In separate bus mode, the state of the pins in the idle state inserted after the T2 state is shown. In multiplexed bus mode, the state of the pins in the idle state inserted after the T3 state is shown.

**4.** Pulled down during external reset. During internal reset by the watchdog timer, low-voltage detector, or clock monitor, etc., the state of this pin differs according to the OCDM.OCDM0 bit setting.

**5.** DDO output is specified in the on-chip debug mode.

**6.** The bus control pins function alternately as port pins, so they are initialized to the input mode (port mode).

**7.** Operates even in the HALT mode, during DMA operation.

**8.** In separate bus mode: Hi-Z  
In multiplexed bus mode: Undefined

**9.** In separate bus mode

**10.** In port mode: Held  
When alternate function is used: Hi-Z

**Remark** Hi-Z: High impedance

Held: The state during the immediately preceding external bus cycle is held.

L: Low-level output

H: High-level output

–: Input without sampling (not acknowledged)

## 2.4 Pin I/O Circuit Types, I/O Buffer Power Supplies and Connection of Unused Pins

(1/6)

Pin	Alternate Function	Pin No.		I/O Circuit Type	Recommended Connection
		SJ3-H	SK3-H		
		GJ	GM		
<R> P00	TIP61/TOP61/SDA04 <sup>Note 2</sup>	6	6	10-D	Input: Independently connect to EV <sub>DD</sub> or EV <sub>SS</sub> via a resistor. Output: Leave open.
<R> P01	TIP60/TOP60/SCL04 <sup>Note 2</sup>	7	7		
P02	NMI	17	19		
P03	INTP0/ADTRG	18	20		
P04	INTP1	19	21		
P05	INTP2/ $\overline{DRST}$	20	22	10-N	Input: Independently connect to EV <sub>SS</sub> via a resistor. Fixing to V <sub>DD</sub> level is prohibited. Output: Leave open. Internally pull-down after reset by $\overline{RESET}$ pin.
P06	INTP3	21	23	10-D	Input: Independently connect to EV <sub>DD</sub> or EV <sub>SS</sub> via a resistor. Output: Leave open.
P10	ANO0	3	3	12-D	Input: Independently connect to AV <sub>REF1</sub> or AV <sub>SS</sub> via a resistor. Output: Leave open.
P11	ANO1	4	4		
P20 <sup>Note 1</sup>	SDA04	–	8	10-D	Input: Independently connect to EV <sub>DD</sub> or EV <sub>SS</sub> via a resistor. Output: Leave open.
P21 <sup>Note 1</sup>	SCL04	–	9		
P30	TXDA0/SOB4	25	30	10-G	Input: Independently connect to EV <sub>DD</sub> or EV <sub>SS</sub> via a resistor. Output: Leave open.
P31	RXDA0/INTP7/SIB4	26	31	10-D	
P32	ASCKA0/ $\overline{SCKB4}$ /TIP00/TOP00	27	32	10-D	
P33	TIP01/TOP01/CTXD1 <sup>Note 3</sup>	28	33		
P34	TIP10/TOP10/CRXD1 <sup>Note 3</sup>	29	34		
P35	TIP11/TOP11	30	35		
P36	CTXD0 <sup>Note 4</sup> / $\overline{IETX0}$	31	36	10-G	
P37	CRXD0 <sup>Note 4</sup> / $\overline{IERX0}$	32	37	10-D	
P38	TXDA2/SDA00/SIB2	35	40		
P39	RXDA2/SCL00/ $\overline{SCKB2}$	36	41		
P310 <sup>Note 1</sup>	SOB2 <sup>Note 1</sup>	–	42	10-G	Input: Independently connect to EV <sub>DD</sub> or EV <sub>SS</sub> via a resistor. Output: Leave open.
P311 <sup>Note 1</sup>	TXDA2 <sup>Note 1</sup>	–	43	10-D	
P312 <sup>Note 1</sup>	RXDA2 <sup>Note 1</sup>	–	44		

**Notes 1.** V850E/SK3-H only

- <R> **2.** Not available in the  $\mu$ PD70F3931 (V850E/SJ3-H), 70F3932 (V850E/SJ3-H), and 70F3933 (V850E/SJ3-H)
- 3.** CAN controller (2-channel) version only
- 4.** CAN controller version only

**Remark** SJ3-H: V850E/SJ3-H

SK3-H: V850E/SK3-H

GJ (V850E/SJ3-H): 144-pin plastic LQFP (fine pitch) (20 × 20)

GM (V850E/SK3-H): 176-pin plastic LQFP (fine pitch) (24 × 24)

Pin	Alternate Function	Pin No.		I/O Circuit Type	Recommended Connection
		SJ3-H	SK3-H		
		GJ	GM		
P40	SIB0/SDA01	22	24	10-D	Input: Independently connect to EV <sub>DD</sub> or EV <sub>SS</sub> via a resistor. Output: Leave open.
P41	SOB0/SCL01	23	25		
P42	$\overline{\text{SCKB0}}$ /INTP2	24	26		
P43 <sup>Note 1</sup>	–	–	27	10-G	
P44 <sup>Note 1</sup>	$\overline{\text{IETX0}}$ <sup>Note 1</sup>	–	28		
P45 <sup>Note 1</sup>	$\overline{\text{IERX0}}$ <sup>Note 1</sup>	–	29	10-D	
P50	KR0/TIQ01/TOQ01/RTP00	37	45		
P51	INTP7/KR1/TIQ02/TOQ02/ RTP01	38	46		
P52	KR2/TIQ03/TOQ03/RTP02/ DDI	39	47		
P53	SIB2/KR3/TIQ00/TOQ00/ RTP03/DDO	40	48		
P54	SOB2/KR4/RTP04/DCK	41	49		
P55	$\overline{\text{SCKB2}}$ /KR5/RTP05/DMS	42	50		
P56 <sup>Note 1</sup>	RXDA4 <sup>Note 1</sup>	–	51		
P57 <sup>Note 1</sup>	TXDA4 <sup>Note 1</sup>	–	52		10-G
<R> P60	RTP10/RXDA4/SIE0 <sup>Note 2</sup>	43	53		10-D
<R> P61	RTP11/TXDA4/SOE0 <sup>Note 2</sup>	44	54	10-G	
<R> P62	RTP12/ $\overline{\text{SCKE0}}$ <sup>Note 2</sup>	45	55	10-D	
<R> P63	RTP13/SIE1 <sup>Note 2</sup> /KR4	46	56		
<R> P64	RTP14/SOE1 <sup>Note 2</sup> /KR5	47	57		
<R> P65	RTP15/ $\overline{\text{SCKE1}}$ <sup>Note 2</sup> /KR2/ TIQ03/TOQ03	48	58		
P66	SIB5/INTP9/KR3/TIQ00/ TOQ00	49	59		
<R> P67	SOB5/RXDA5/SDA05 <sup>Note 2</sup>	50	60		
<R> P68	$\overline{\text{SCKB5}}$ /TXDA5/SCL05 <sup>Note 2</sup>	51	61		
P69	TIP70/TOP70/TENC70	52	62		
P610	TIP71/TENC71	53	63		
P611	TOP71/TECR7	54	64		
P612	TIP80/TOP80/TENC80	55	65		
P613	TIP81/TOP81/TENC81	56	66		
P614	SDA03/TECR8	57	67		
P615	SCL03	58	68		

**Notes 1.** V850E/SK3-H only

<R> **2.** Not available in the  $\mu$ PD70F3931 (V850E/SJ3-H), 70F3932 (V850E/SJ3-H), and 70F3933 (V850E/SJ3-H)

**Remark** SJ3-H: V850E/SJ3-H

SK3-H: V850E/SK3-H

GJ (V850E/SJ3-H): 144-pin plastic LQFP (fine pitch) (20 × 20)

GM (V850E/SK3-H): 176-pin plastic LQFP (fine pitch) (24 × 24)

Pin	Alternate Function	Pin No.		I/O Circuit Type	Recommended Connection
		SJ3-H	SK3-H		
		GJ	GM		
P70	ANI0	144	176	11-G	Input: Independently connect to AV <sub>REF0</sub> or AV <sub>SS</sub> via a resistor. Output: Leave open.
P71	ANI1	143	175		
P72	ANI2	142	174		
P73	ANI3	141	173		
P74	ANI4	140	172		
P75	ANI5	139	171		
P76	ANI6	138	170		
P77	ANI7	137	169		
P78	ANI8	136	168		
P79	ANI9	135	167		
P710	ANI10	134	166		
P711	ANI11	133	165		
P712	ANI12	132	164		
P713	ANI13	131	163		
P714	ANI14	130	162		
P715	ANI15	129	161		
P80	RXDA3/INTP8/RC1CK1HZ	59	71	10-D	Input: Independently connect to EV <sub>DD</sub> or EV <sub>SS</sub> via a resistor. Output: Leave open.
P81	TXDA3/RC1CK0/RC1CKDIV	60	72	10-G	
P82 <sup>Note</sup>	SDA05 <sup>Note</sup>	–	73	10-D	
P83 <sup>Note</sup>	SCL05 <sup>Note</sup>	–	74		
P84 <sup>Note</sup>	RXDA5 <sup>Note</sup>	–	75		
P85 <sup>Note</sup>	TXDA5 <sup>Note</sup>	–	76	10-G	
P90	A0/KR6/TXDA1/SDA02	61	77	10-D	
P91	A1/KR7/RXDA1/KR7/SCL02	62	78		
P92	A2/TIP41/TOP41	63	79		
P93	A3/TIP40/TOP40/INTP8	64	80		
P94	A4/TIP31/TOP31	65	81		
P95	A5/TIP30/TOP30/INTP5	66	82		
P96	A6/TIP21/TOP21	67	83		
P97	A7/SIB1/TIP20/TOP20	68	84		
P98	A8/SOB1	69	85		10-G
P99	A9/SCKB1	70	86		10-D
P910	A10/SIB3	71	87	10-G	
P911	A11/SOB3	72	88		

**Note** V850E/SK3-H only

**Remark** SJ3-H: V850E/SJ3-H  
SK3-H: V850E/SK3-H  
GJ (V850E/SJ3-H): 144-pin plastic LQFP (fine pitch) (20 × 20)  
GM (V850E/SK3-H): 176-pin plastic LQFP (fine pitch) (24 × 24)

Pin	Alternate Function	Pin No.		I/O Circuit Type	Recommended Connection
		SJ3-H	SK3-H		
		GJ	GM		
P912	A12/SCKB3	73	89	10-D	Input: Independently connect to EV <sub>DD</sub> or EV <sub>SS</sub> via a resistor. Output: Leave open.
P913	A13/INTP4	74	90		
P914	A14/INTP5/TIP51/TOP51	75	91		
P915	A15/INTP6/TIP50/TOP50	76	92		
P130 <sup>Note</sup>	–	–	125	5	Input: Independently connect to BV <sub>DD</sub> or BV <sub>SS</sub> via a resistor. Output: Leave open.
P131 <sup>Note</sup>	–	–	126		
P132 <sup>Note</sup>	–	–	127		
P133 <sup>Note</sup>	–	–	128		
P140 <sup>Note</sup>	–	–	155		
P141 <sup>Note</sup>	–	–	156		
P142 <sup>Note</sup>	–	–	157		
P143 <sup>Note</sup>	–	–	158		
P144 <sup>Note</sup>	–	–	159		
P145 <sup>Note</sup>	–	–	160		
P150 <sup>Note</sup>	RXDA1 <sup>Note</sup> /KR7 <sup>Note</sup>	–	93		
P151 <sup>Note</sup>	TXDA1 <sup>Note</sup>	–	94	10-G	
P152 <sup>Note</sup>	INTP9 <sup>Note</sup>	–	95	10-D	Input: Independently connect to BV <sub>DD</sub> or BV <sub>SS</sub> via a resistor. Output: Leave open.
P153 <sup>Note</sup>	INTP6 <sup>Note</sup>	–	96		
PCD0	RXDB0	77	97	10-G	Output: Leave open.
PCD1	TXDB0	78	98		
PCD2	RXDB1	79	99		
PCD3	TXDB1	80	100		
PCM0	WAIT	85	105	5	
PCM1	CLKOUT	86	106		
PCM2	HLDAK	87	107		
PCM3	HLDRQ	88	108		
PCM4	–	89	109		
PCM5	–	90	110		
PCS0	–	81	101		
PCS1	CS1	82	102		
PCS2	CS2	83	103		
PCS3	CS3	84	104		
PCS4	–	91	111		
PCS5	–	92	112		
PCS6	–	93	113		
PCS7	–	94	114		

**Note** V850E/SK3-H only

**Remark** SJ3-H: V850E/SJ3-H

SK3-H: V850E/SK3-H

GJ (V850E/SJ3-H): 144-pin plastic LQFP (fine pitch) (20 × 20)

GM (V850E/SK3-H): 176-pin plastic LQFP (fine pitch) (24 × 24)

Pin	Alternate Function	Pin No.		I/O Circuit Type	Recommended Connection
		SJ3-H	SK3-H		
		GJ	GM		
PCT0	$\overline{WR0}$	95	115	5	Input: Independently connect to $BV_{DD}$ or $BV_{SS}$ via a resistor. Output: Leave open.
PCT1	$\overline{WR1}$	96	116		
PCT2	–	97	117		
PCT3	–	98	118		
PCT4	$\overline{RD}$	99	119		
PCT5	–	100	120		
PCT6	ASTB	101	121		
PCT7	–	102	122		
PDH0	A16	121	145		
PDH1	A17	122	146		
PDH2	A18	123	147		
PDH3	A19	124	148		
PDH4	A20	125	149		
PDH5	A21	126	150		
PDH6	A22	127	151		
PDH7	A23	128	152		
PDL0	AD0	105	129		
PDL1	AD1	106	130		
PDL2	AD2	107	131		
PDL3	AD3	108	132		
PDL4	AD4	109	133		
PDL5	AD5/FLMD1	110	134		Independently connect to $BV_{SS}$ via a resistor.
PDL6	AD6	111	135		Input: Independently connect to $BV_{DD}$ or $BV_{SS}$ via a resistor. Output: Leave open.
PDL7	AD7	112	136		
PDL8	AD8	113	137		
PDL9	AD9	114	138		
PDL10	AD10	115	139		
PDL11	AD11	116	140		
PDL12	AD12	117	141		
PDL13	AD13	118	142		
PDL14	AD14	119	143		
PDL15	AD15	120	144		

**Remark** SJ3-H: V850E/SJ3-H  
SK3-H: V850E/SK3-H  
GJ (V850E/SJ3-H): 144-pin plastic LQFP (fine pitch) (20 × 20)  
GM (V850E/SK3-H): 176-pin plastic LQFP (fine pitch) (24 × 24)



Pin	Alternate Function	Pin No.		I/O Circuit Type	Recommended Connection
		SJ3-H	SK3-H		
		GJ	GM		
AV <sub>REF0</sub>	–	1	1	–	Always connect this pin to the power supply (also in the standby mode).
AV <sub>REF1</sub>	–	5	5	–	
AV <sub>SS</sub>	–	2	2	–	Always connect this pin directly to the ground (also in the standby mode).
BV <sub>DD</sub>	–	104	124	–	Always connect this pin to the power supply (also in the standby mode).
	–	–	153		
BV <sub>SS</sub>	–	103	123	–	Always connect this pin directly to the ground (also in the standby mode).
	–	–	154		
EV <sub>DD</sub>	–	34	39	–	Always connect this pin directly to the power supply (also in the standby mode).
	–	–	69		
EV <sub>SS</sub>	–	33	38	–	Always connect this pin directly to the ground (also in the standby mode).
	–	–	70		
FLMDO	–	8	10	–	Connect to V <sub>SS</sub> in a mode other than the flash memory programming mode.
REGC	–	10	12	–	Connect regulator output stabilization capacitance (4.7 $\mu$ F)
$\overline{\text{RESET}}$	–	14	16	2	–
V <sub>DD</sub>	–	9	11	–	Always connect this pin to the power supply (also in the standby mode).
V <sub>SS</sub>	–	11	13	–	Always connect this pin directly to the ground (also in the standby mode).
X1	–	12	14	–	–
X2	–	13	15	–	–
XT1	–	15	17	16-C	Connect to V <sub>SS</sub> .
XT2	–	16	18		Leave open.

**Remark** SJ3-H: V850E/SJ3-H

SK3-H: V850E/SK3-H

GJ (V850E/SJ3-H): 144-pin plastic LQFP (fine pitch) (20 × 20)

GM (V850E/SK3-H): 176-pin plastic LQFP (fine pitch) (24 × 24)

Figure 2-3. Pin I/O Circuits

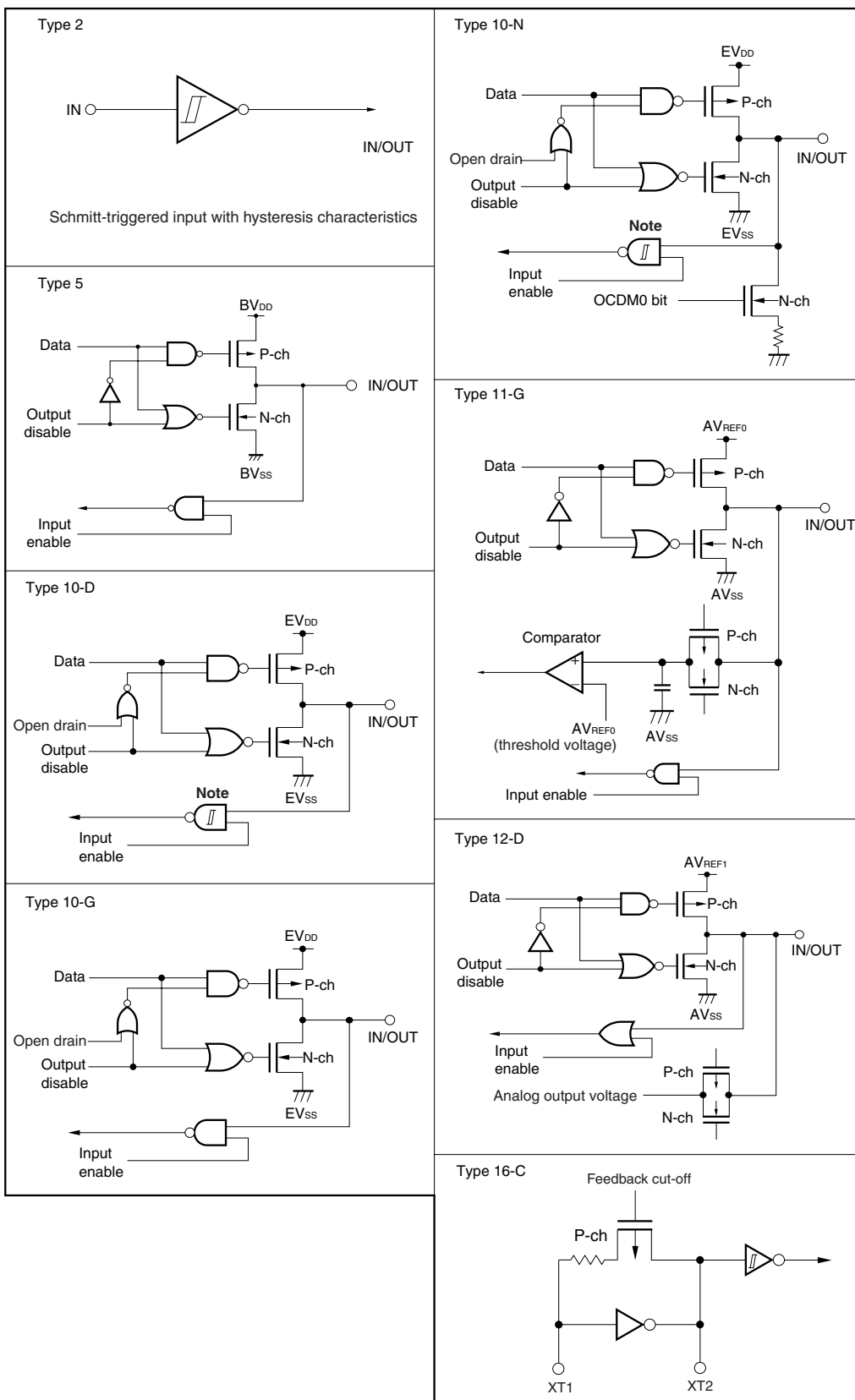

**Note** Hysteresis characteristics are not available in port mode.

## 2.5 Cautions

### (1) Cautions on power application

When the power is turned on, the following pins may momentarily output an undefined level.

- P53/SIB2/KR3/TIQ00/TOQ00/RTP03/DDO pin

## CHAPTER 3 CPU FUNCTION

The CPU of the V850E/SJ3-H and V850E/SK3-H is based on RISC architecture and executes almost all instructions with one clock by using a 5-stage pipeline.

### 3.1 Features

- Minimum instruction execution time: 20.8 ns (operating with 48 MHz)  
30.5  $\mu$ s (operating with subclock ( $f_{\text{CT}}$ ) = 32.768 kHz operation)
- Memory space    Program (physical address) space: 64 MB linear  
                          Data (logical address) space:     4 GB linear
- General-purpose registers: 32 bits  $\times$  32 registers
- Internal 32-bit architecture
- 5-stage pipeline control
- Multiplication/division instruction
- Saturation operation instruction
- 32-bit shift instruction: 1 clock
- Load/store instruction with long/short format
- Four types of bit manipulation instructions
  - SET1
  - CLR1
  - NOT1
  - TST1

### 3.2 CPU Register Set

The registers of the V850E/SJ3-H and V850E/SK3-H can be classified into two types: general-purpose program registers and dedicated system registers. All the registers are 32 bits wide.

For details, refer to the **V850E1 Architecture User's Manual**.

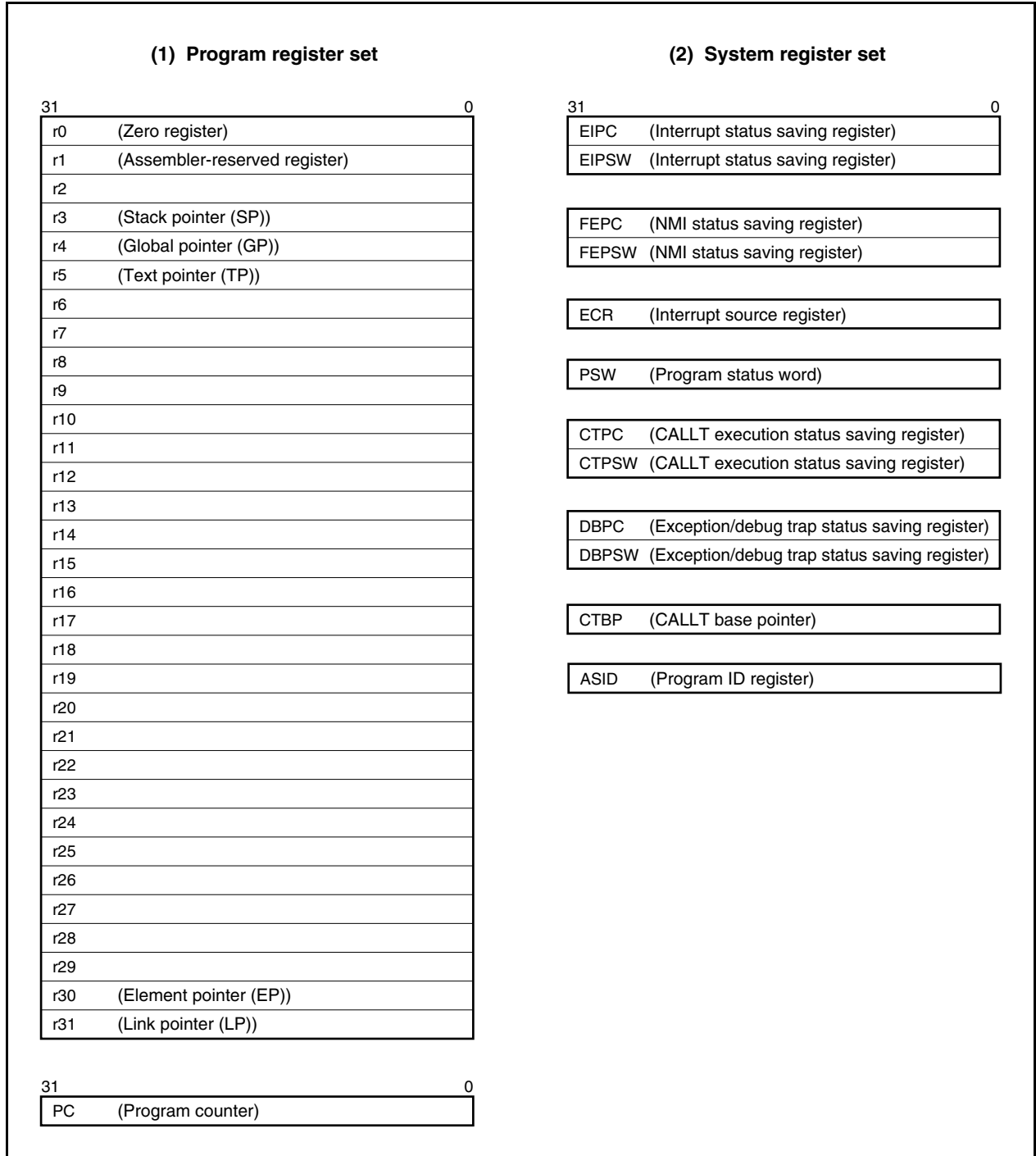

**3.2.1 Program register set**

The program registers include general-purpose registers and a program counter.

**(1) General-purpose registers (r0 to r31)**

Thirty-two general-purpose registers, r0 to r31, are available. Any of these registers can be used to store a data variable or an address variable.

However, r0 and r30 are implicitly used by instructions and care must be exercised when these registers are used. r0 always holds 0 and is used for an operation that uses 0 or addressing of offset 0. r30 is used by the SLD and SST instructions as a base pointer when these instructions access the memory. r1, r3 to r5, and r31 are implicitly used by the assembler and C compiler. When using these registers, save their contents for protection, and then restore the contents after using the registers. r2 is sometimes used by the real-time OS. If the real-time OS does not use r2, it can be used as a register for variables.

**Table 3-1. General-Purpose Registers**

Name	Usage	Operation
r0	Zero register	Always holds 0.
r1	Assembler-reserved register	Used as working register to create 32-bit immediate data
r2	Register for address/data variable (if real-time OS does not use r2)	
r3	Stack pointer	Used to create a stack frame when a function is called
r4	Global pointer	Used to access a global variable in the data area
r5	Text pointer	Used as register that indicates the beginning of a text area (area where program codes are located)
r6 to r29	Register for address/data variable	
r30	Element pointer	Used as base pointer to access memory
r31	Link pointer	Used when the compiler calls a function

**Remark** For further details on the r1, r3 to r5, and r31 that are used in the assembler and C compiler, refer to the **CA850 (C Compiler Package) Assembly Language User's Manual**.

**(2) Program counter (PC)**

The program counter holds the instruction address during program execution. The lower 26 bits of this register are valid. Bits 31 to 26 are fixed to 0. A carry from bit 25 to 26 is ignored even if it occurs.

Bit 0 is fixed to 0. This means that execution cannot branch to an odd address.

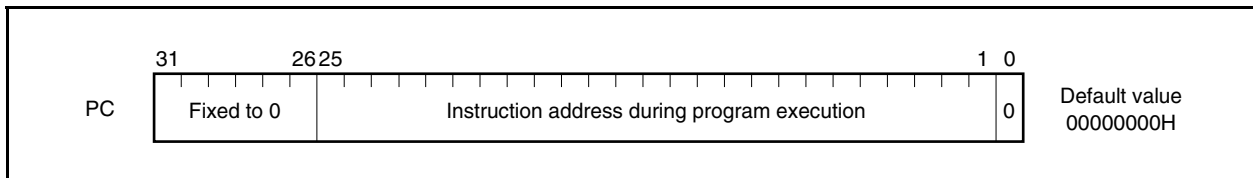

### 3.2.2 System register set

The system registers control the status of the CPU and hold interrupt information.

These registers can be read or written by using system register load/store instructions (LDSR and STSR), using the system register numbers listed below.

**Table 3-2. System Register Numbers**

System Register Number	System Register Name	Operand Specification	
		LDSR Instruction	STSR Instruction
0	Interrupt status saving register (EIPC) <sup>Note 1</sup>	√	√
1	Interrupt status saving register (EIPSW) <sup>Note 1</sup>	√	√
2	NMI status saving register (FEPC) <sup>Note 1</sup>	√	√
3	NMI status saving register (FEPSW) <sup>Note 1</sup>	√	√
4	Interrupt source register (ECR)	×	√
5	Program status word (PSW)	√	√
6 to 15	Reserved for future function expansion (operation is not guaranteed if these registers are accessed)	×	×
16	CALLT execution status saving register (CTPC)	√	√
17	CALLT execution status saving register (CTPSW)	√	√
18	Exception/debug trap status saving register (DBPC)	√ <sup>Note 2</sup>	√ <sup>Note 2</sup>
19	Exception/debug trap status saving register (DBPSW)	√ <sup>Note 2</sup>	√ <sup>Note 2</sup>
20	CALLT base pointer (CTBP)	√	√
21, 22	Reserved for future function expansion (operations that access these register numbers cannot be guaranteed).	×	×
23	Program ID register (ASID)	√	√
24 to 31	Reserved for future function expansion (operations that access these register numbers cannot be guaranteed).	×	×

**Notes 1.** Because only one set of these registers is available, the contents of these registers must be saved by program if multiple interrupts are enabled.

**2.** These registers can be accessed only during the interval between the execution of the DBTRAP instruction or illegal opcode and the DBRET instruction.

**Caution** Even if EIPC or FEPC, or bit 0 of CTPC is set to 1 by the LDSR instruction, bit 0 is ignored when execution is returned to the main routine by the RETI instruction after interrupt servicing (this is because bit 0 of the PC is fixed to 0). Set an even value to EIPC, FEPC, and CTPC (bit 0 = 0).

**Remark** √: Can be accessed  
×: Access prohibited

**(1) Interrupt status saving registers (EIPC and EIPSW)**

EIPC and EIPSW are used to save the status when an interrupt occurs.

If a software exception or a maskable interrupt occurs, the contents of the program counter (PC) are saved to EIPC, and the contents of the program status word (PSW) are saved to EIPSW (these contents are saved to the NMI status saving registers (FEPC and FEPSW) if a non-maskable interrupt occurs).

The address of the instruction next to the instruction under execution, except some instructions (see **24.8 Periods in Which Interrupts Are Not Acknowledged by CPU**), is saved to EIPC when a software exception or a maskable interrupt occurs.

The current contents of the PSW are saved to EIPSW.

Because only one set of interrupt status saving registers is available, the contents of these registers must be saved by program when multiple interrupts are enabled.

Bits 31 to 26 of EIPC and bits 31 to 8 of EIPSW are reserved for future function expansion (these bits are always fixed to 0).

The value of EIPC is restored to the PC and the value of EIPSW to the PSW by the RETI instruction.

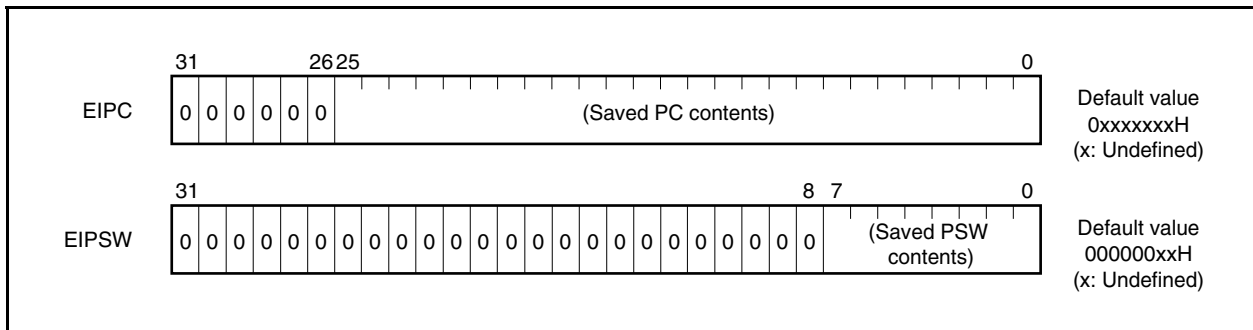



**(2) NMI status saving registers (FEPC and FEPSW)**

FEPC and FEPSW are used to save the status when a non-maskable interrupt (NMI) occurs.

If an NMI occurs, the contents of the program counter (PC) are saved to FEPC, and those of the program status word (PSW) are saved to FEPSW.

The address of the instruction next to the one of the instruction under execution, except some instructions, is saved to FEPC when an NMI occurs.

The current contents of the PSW are saved to FEPSW.

Because only one set of NMI status saving registers is available, the contents of these registers must be saved by program when multiple interrupts are enabled.

Bits 31 to 26 of FEPC and bits 31 to 8 of FEPSW are reserved for future function expansion (these bits are always fixed to 0).

The value of FEPC is restored to the PC and the value of FEPSW to the PSW by the RETI instruction.

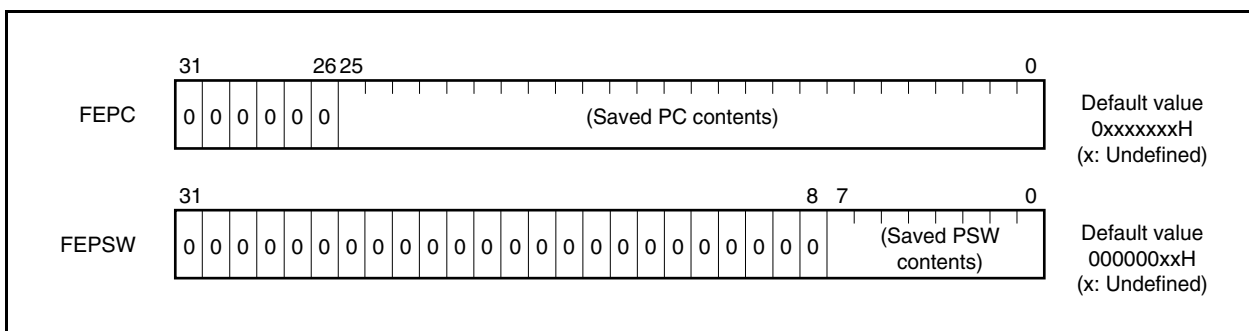

**(3) Interrupt source register (ECR)**

The interrupt source register (ECR) holds the source of an exception or interrupt if an exception or interrupt occurs. This register holds the exception code of each interrupt source. Because this register is a read-only register, data cannot be written to this register using the LDSR instruction.

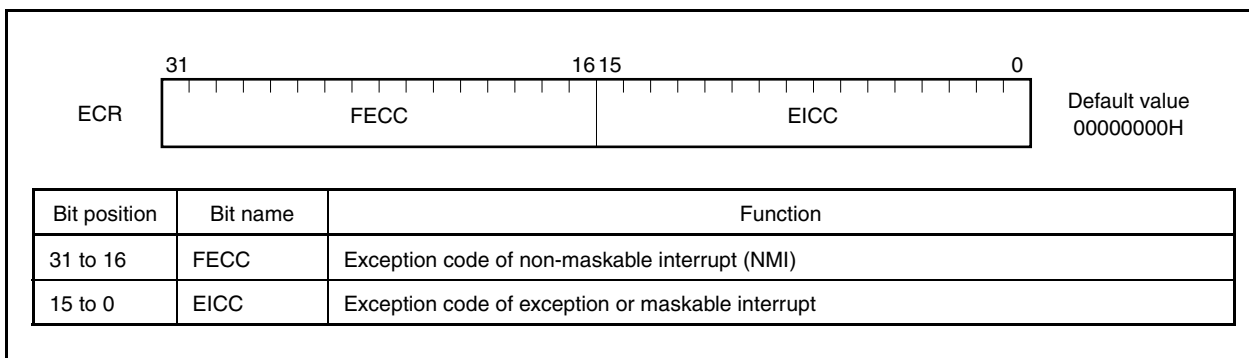

**(4) Program status word (PSW)**

The program status word (PSW) is a collection of flags that indicate the status of the program (result of instruction execution) and the status of the CPU.

If the contents of a bit of this register are changed by using the LDSR instruction, the new contents are validated immediately after completion of LDSR instruction execution. However if the ID flag is set to 1, interrupt requests will not be acknowledged while the LDSR instruction is being executed.

Bits 31 to 8 of this register are reserved for future function expansion (these bits are fixed to 0).

(1/2)



Bit position	Flag name	Function
31 to 8	RFU	Reserved field. Fixed to 0.
7	NP	Indicates that a non-maskable interrupt (NMI) is being serviced. This bit is set to 1 when an NMI request is acknowledged, disabling multiple interrupts. 0: NMI is not being serviced. 1: NMI is being serviced.
6	EP	Indicates that an exception is being processed. This bit is set to 1 when an exception occurs. Even if this bit is set, interrupt requests are acknowledged. 0: Exception is not being processed. 1: Exception is being processed.
5	ID	Indicates whether a maskable interrupt can be acknowledged. 0: Interrupt enabled 1: Interrupt disabled
4	SAT <sup>Note</sup>	Indicates that the result of a saturation operation has overflowed and is saturated. Because this is a cumulative flag, it is set to 1 when the result of a saturation operation instruction is saturated, and is not cleared to 0 even if the subsequent operation result is not saturated. Use the LDSR instruction to clear this bit. This flag is neither set to 1 nor cleared to 0 by execution of an arithmetic operation instruction. 0: Not saturated 1: Saturated
3	CY	Indicates whether a carry or a borrow occurs as a result of an operation. 0: Carry or borrow does not occur. 1: Carry or borrow occurs.
2	OV <sup>Note</sup>	Indicates whether an overflow occurs during operation. 0: Overflow does not occur. 1: Overflow occurs.
1	S <sup>Note</sup>	Indicates whether the result of an operation is negative. 0: The result is positive or 0. 1: The result is negative.
0	Z	Indicates whether the result of an operation is 0. 0: The result is not 0. 1: The result is 0.

**Remark** Also read **Note** on the next page.

**Note** The result of the operation that has performed saturation processing is determined by the contents of the OV and S flags. The SAT flag is set to 1 only when the OV flag is set to 1 when a saturation operation is performed.

Status of operation result	Flag status			Result of operation of saturation processing
	SAT	OV	S	
Maximum positive value is exceeded	1	1	0	7FFFFFFFH
Maximum negative value is exceeded	1	1	1	80000000H
Positive (maximum value is not exceeded)	Holds value before operation	0	0	Operation result itself
Negative (maximum value is not exceeded)			1	

**(5) CALLT execution status saving registers (CTPC and CTPSW)**

CTPC and CTPSW are CALLT execution status saving registers.

When the CALLT instruction is executed, the contents of the program counter (PC) are saved to CTPC, and those of the program status word (PSW) are saved to CTPSW.

The contents saved to CTPC are the address of the instruction next to CALLT.

The current contents of the PSW are saved to CTPSW.

Bits 31 to 26 of CTPC and bits 31 to 8 of CTPSW are reserved for future function expansion (fixed to 0).

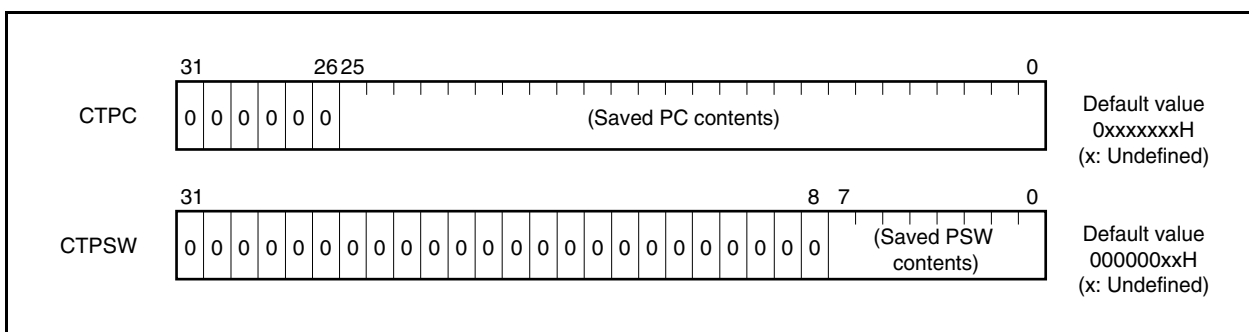

**(6) Exception/debug trap status saving registers (DBPC and DBPSW)**

DBPC and DBPSW are exception/debug trap status registers.

If an exception trap or debug trap occurs, the contents of the program counter (PC) are saved to DBPC, and those of the program status word (PSW) are saved to DBPSW.

The contents to be saved to DBPC are the address of the instruction next to the one that is being executed when an exception trap or debug trap occurs.

The current contents of the PSW are saved to DBPSW.

This register can be read or written only during the interval between the execution of the DBTRAP instruction or illegal opcode and the DBRET instruction.

Bits 31 to 26 of DBPC and bits 31 to 8 of DBPSW are reserved for future function expansion (fixed to 0).

The value of DBPC is restored to the PC and the value of DBPSW to the PSW by the DBRET instruction.

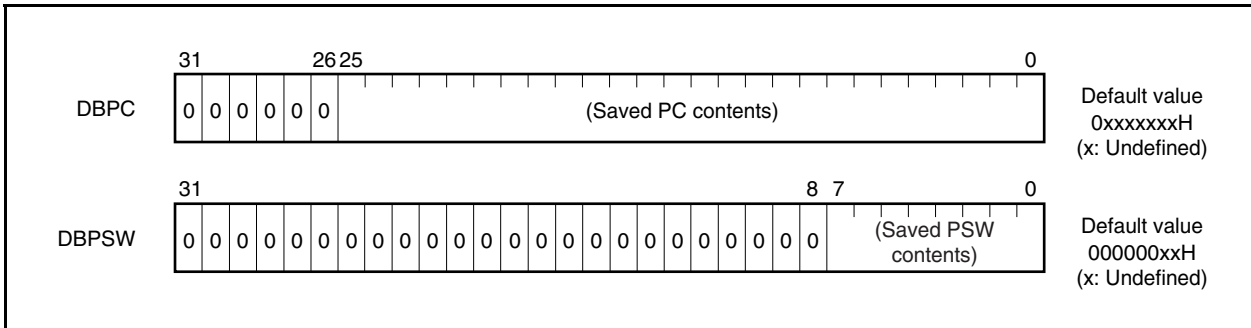

**(7) CALLT base pointer (CTBP)**

The CALLT base pointer (CTBP) is used to specify a table address or generate a target address (bit 0 is fixed to 0).

Bits 31 to 26 of this register are reserved for future function expansion (fixed to 0).

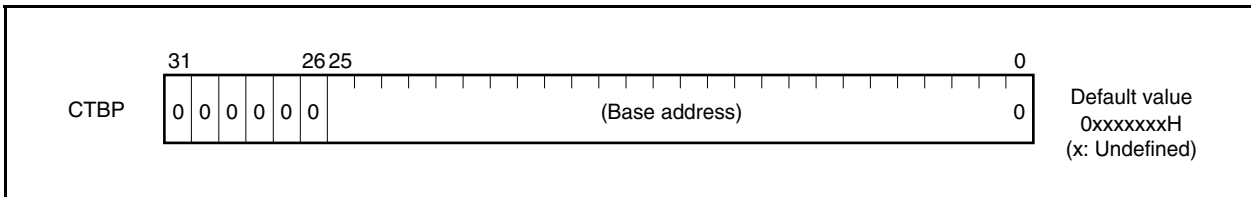

**(8) Program ID register (ASID)**

ASID sets the ID of the program in progress.

Bits 31 to 8 of this register are reserved for future function expansion (fixed to 0).

**Caution** To use the V850E/SJ3-H or V850E/SK3-H, initialize the ASID register to 00H in its initialization routine.

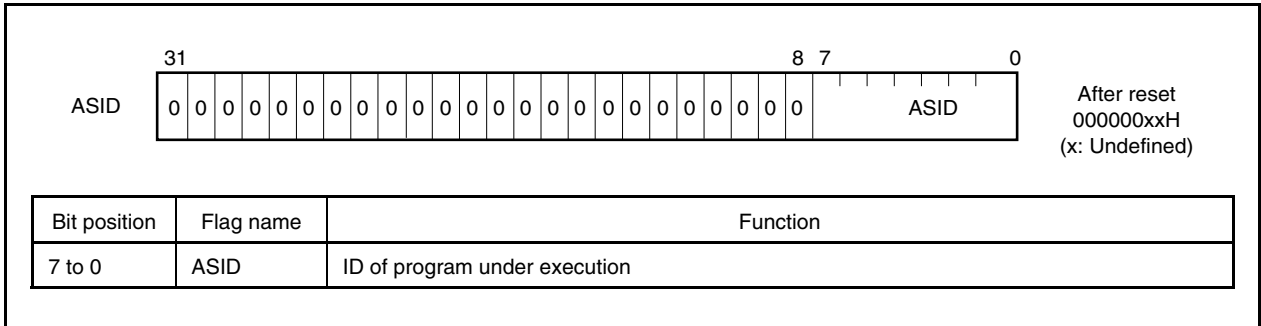

### 3.3 Operation Modes

The V850E/SJ3-H and V850E/SK3-H have the following operation modes.

#### (1) Normal operation mode

In this mode, each pin related to the bus interface is set to the port mode after system reset has been released. Execution branches to the reset entry address of the internal ROM, and then instruction processing is started.

#### (2) Flash memory programming mode

In this mode, the internal flash memory can be programmed by using a flash memory programmer.

#### (3) On-chip debug mode

The V850E/SJ3-H and V850E/SK3-H are provided with an on-chip debug function that employs the JTAG (Joint Test Action Group) communication specifications and that is executed via an on-chip debug emulator.

For details, see **CHAPTER 34 ON-CHIP DEBUG FUNCTION**.

#### 3.3.1 Specifying operation mode

Specify the operation mode by using the FLMD0 and FLMD1 pins.

In the normal mode, input a low level to the FLMD0 pin when reset is released.

In the flash memory programming mode, a high level is input to the FLMD0 pin from the flash memory programmer if a flash memory programmer is connected, but it must be input from an external circuit in the self-programming mode.

Operation When Reset Is Released		Operation Mode After Reset
FLMD0	FLMD1	
L	×	Normal operation mode
H	L	Flash memory programming mode
H	H	Setting prohibited

**Remark** L: Low-level input  
H: High-level input  
×: Don't care

### 3.4 Address Space

#### 3.4.1 CPU address space

For instruction addressing, up to a combined total of 32 MB of external memory area and internal ROM area, plus an internal RAM area, are supported in a linear address space (program space) of up to 64 MB. For operand addressing (data access), up to 4 GB of a linear address space (data space) is supported. The 4 GB address space, however, is viewed as 64 images of a 64 MB physical address space. This means that the same 64 MB physical address space is accessed regardless of the value of bits 31 to 26.

<R>

Figure 3-1. Image on Address Space

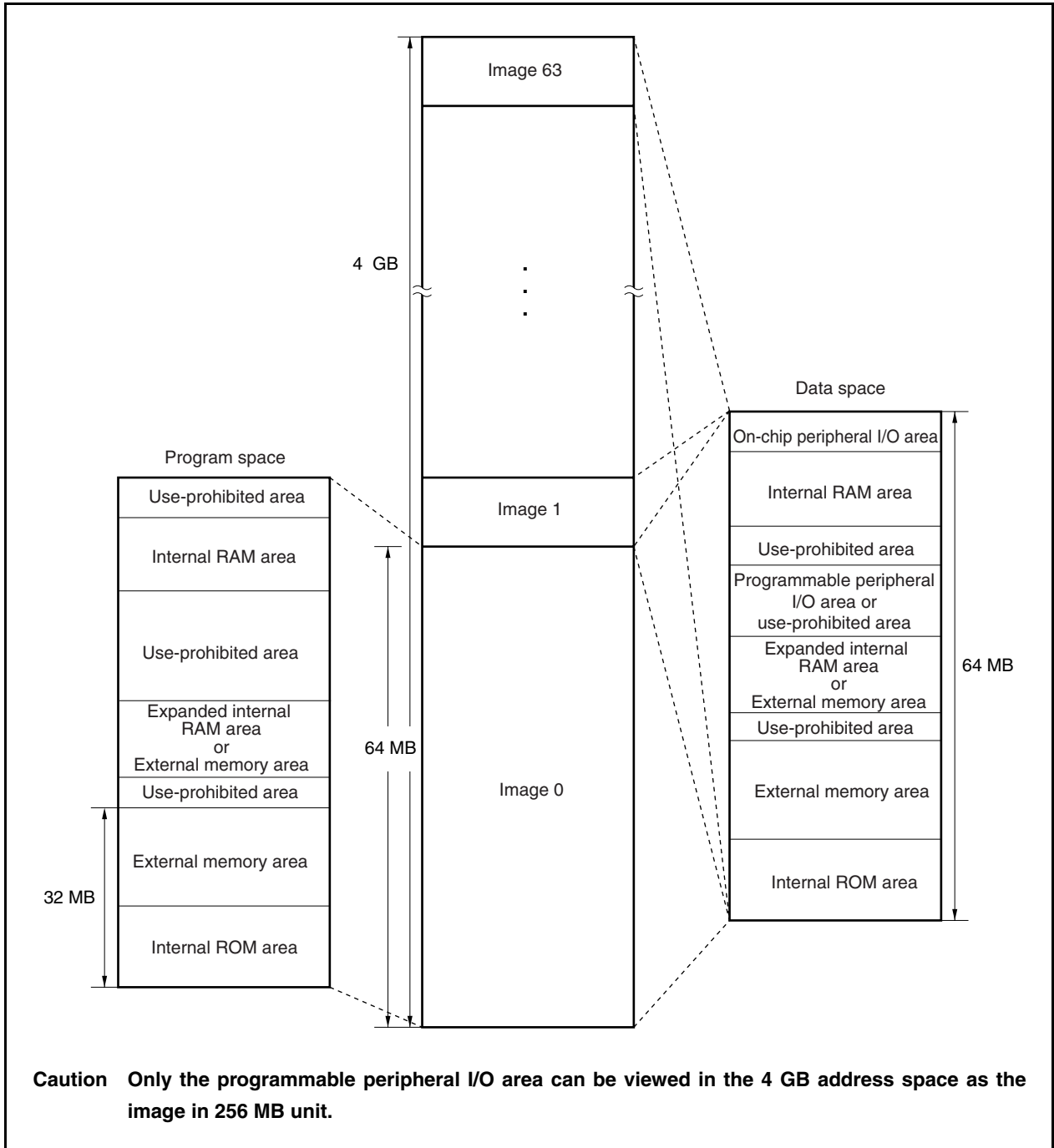

### 3.4.2 Wraparound of CPU address space

#### (1) Program space

Of the 32 bits of the PC (program counter), the higher 6 bits are fixed to 0 and only the lower 26 bits are valid. The higher 6 bits ignore a carry or borrow from bit 25 to 26 during branch address calculation.

Therefore, the highest address of the program space, 03FFFFFFH, and the lowest address, 00000000H, are contiguous addresses. That the highest address and the lowest address of the program space are contiguous in this way is called wraparound.

**Caution** Because the 4 KB area of addresses 03FFF000H to 03FFFFFFH is an on-chip peripheral I/O area, instructions cannot be fetched from this area. Therefore, do not execute an operation in which the result of a branch address calculation affects this area.

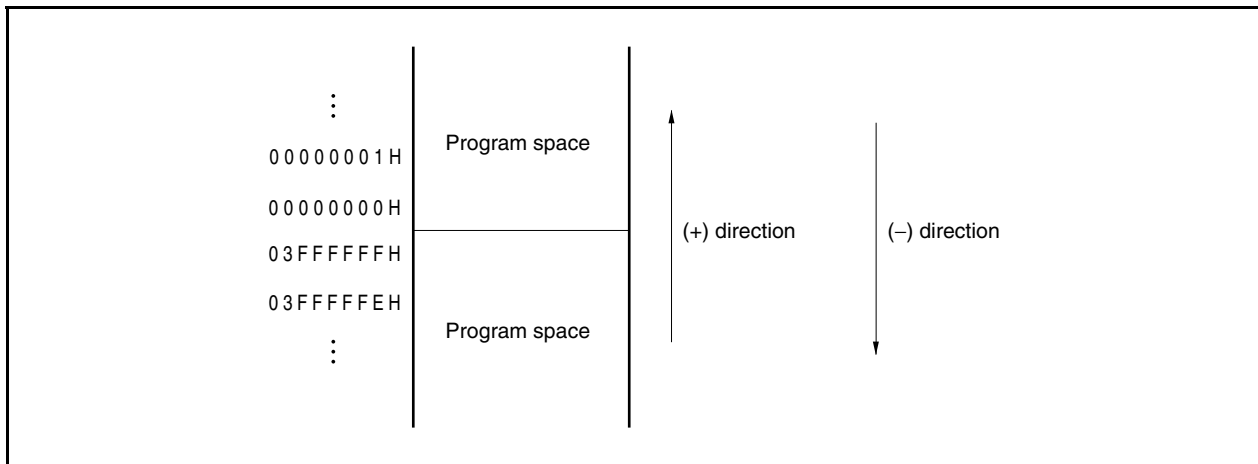

#### (2) Data space

The result of an operand address calculation operation that exceeds 32 bits is ignored.

Therefore, the highest address of the data space, FFFFFFFFH, and the lowest address, 00000000H, are contiguous, and wraparound occurs at the boundary of these addresses.

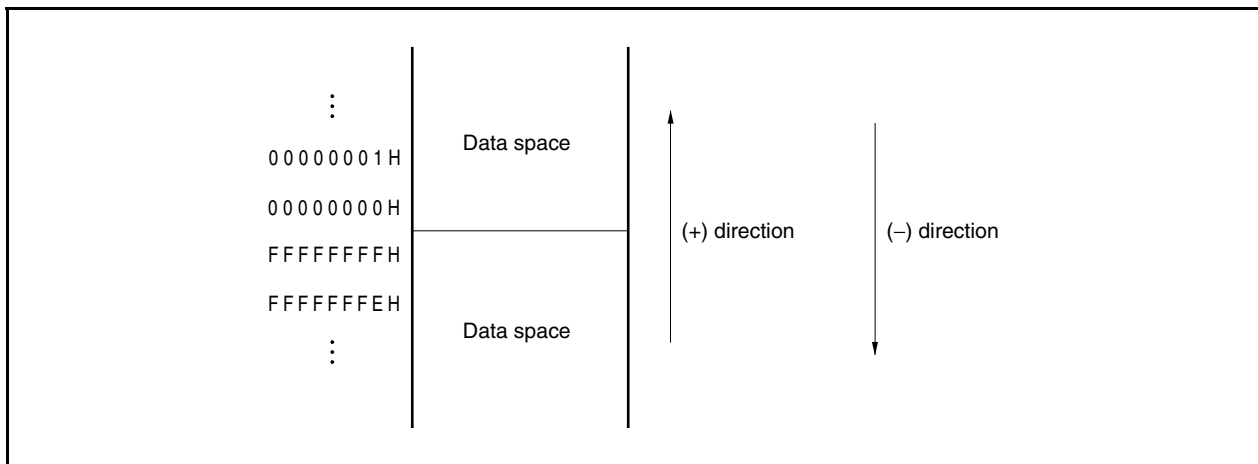



3.4.3 Memory map

The areas shown below are reserved in the V850E/SJ3-H and V850E/SK3-H.

Figure 3-2. Data Memory Map (Physical Addresses) (1/2)

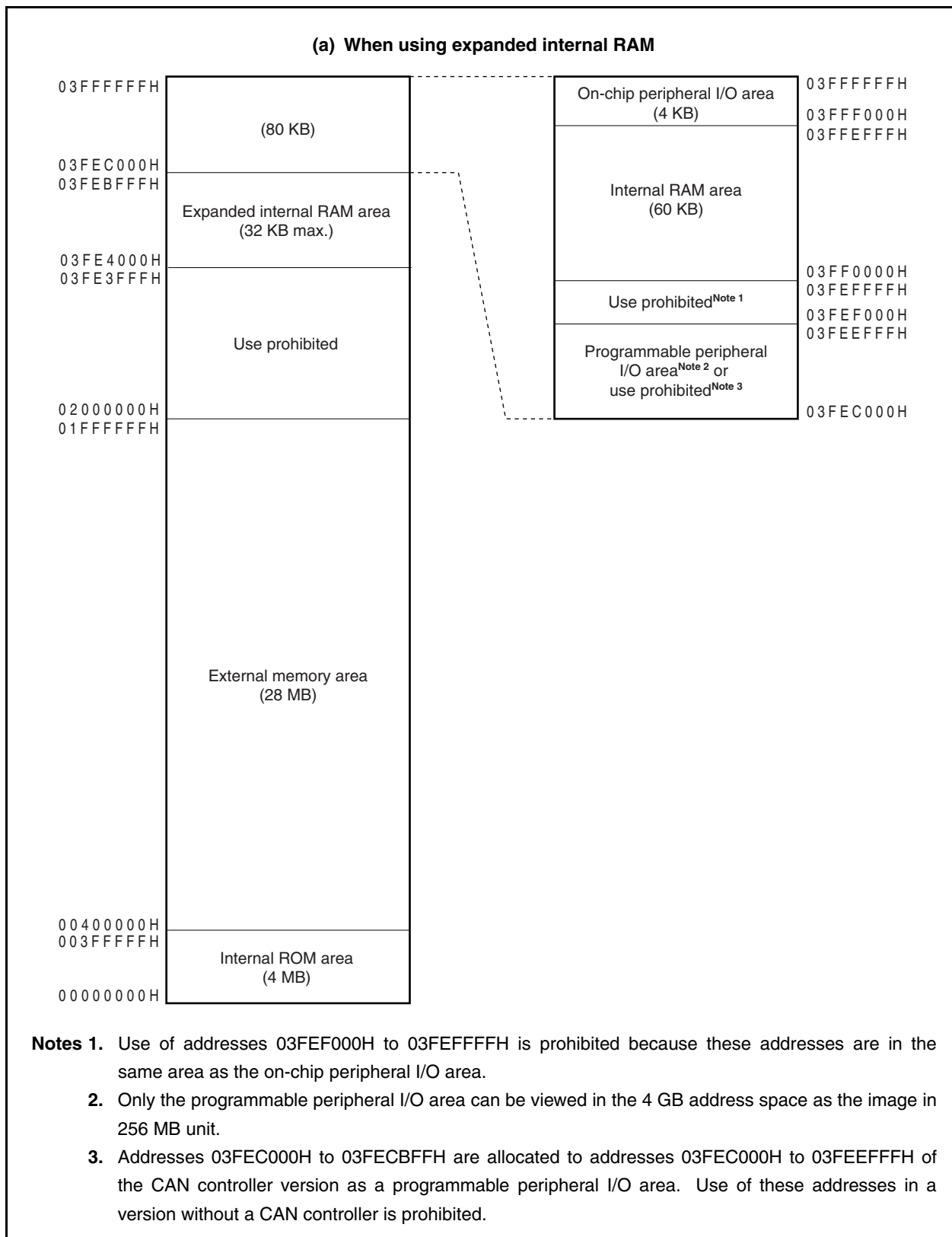
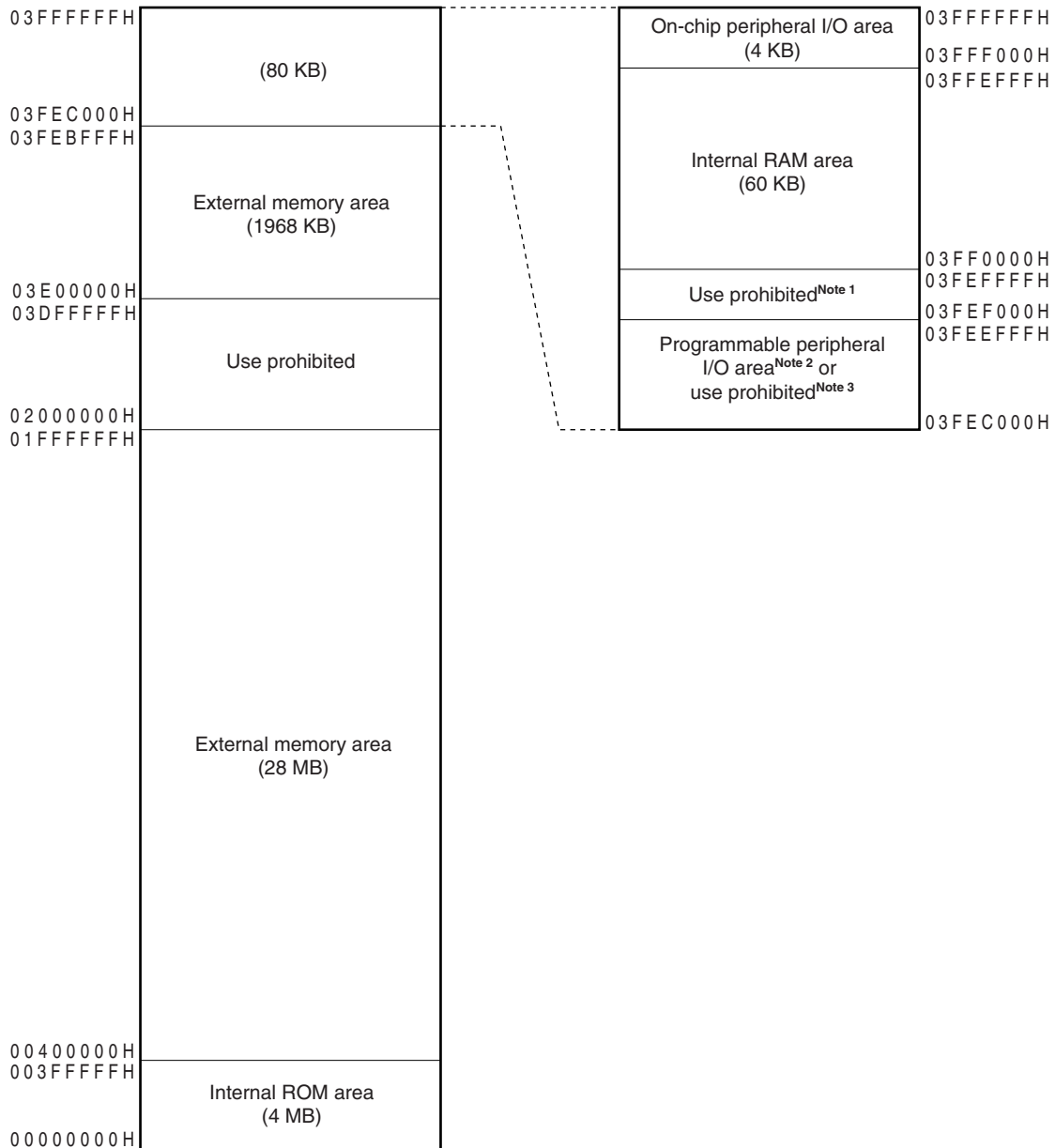

Figure 3-2. Data Memory Map (Physical Addresses) (2/2)

<R>

(b) When not using expanded internal RAM



- Notes 1.** Use of addresses 03FEF000H to 03FEEFFFFH is prohibited because these addresses are in the same area as the on-chip peripheral I/O area.
- 2.** Only the programmable peripheral I/O area can be viewed in the 4 GB address space as the image in 256 MB unit.
- 3.** Addresses 03FEC000H to 03FEEFFFFH are allocated to addresses 03FEC000H to 03FECBFFH of the CAN controller version as a programmable peripheral I/O area. Use of these addresses in a version without a CAN controller is prohibited.

Figure 3-3. Program Memory Map (1/2)

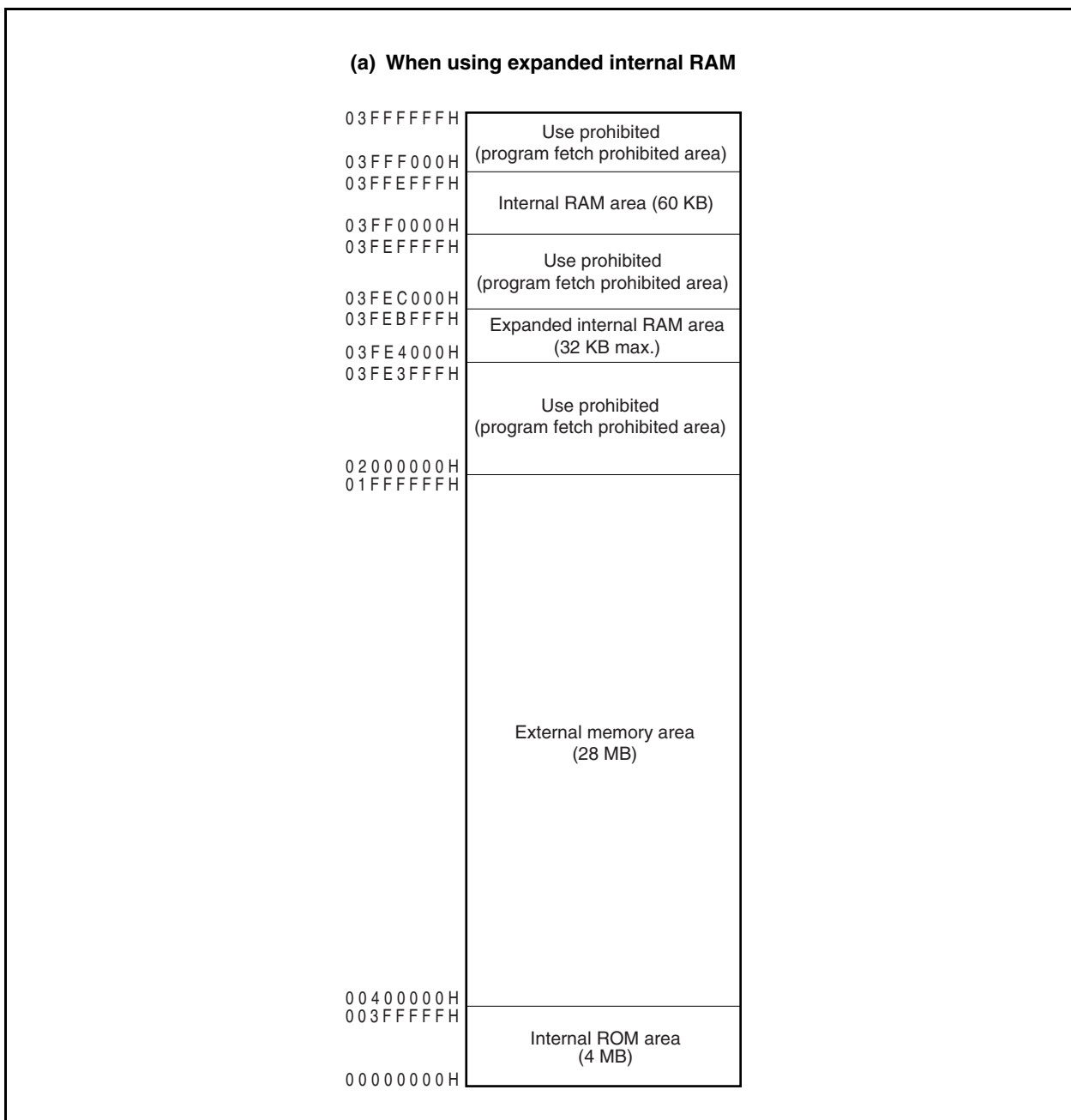

Figure 3-3. Program Memory Map (2/2)

<R>

**(b) When not using expanded internal RAM**

03FFFFFFH	Use prohibited (program fetch prohibited area)
03FFF000H	
03FF0000H	Internal RAM area (60 KB)
03FEFFFFH	
03FEC000H	Use prohibited (program fetch prohibited area)
03FEBFFFFH	
03E00000H	External memory area (1968 KB)
03DFFFFFFH	
02000000H	Use prohibited (program fetch prohibited area)
01FFFFFFH	
	External memory area (28 MB)
00400000H	Internal ROM area (4 MB)
003FFFFFFH	
00000000H	

### 3.4.4 Areas

#### (1) Internal ROM area

Up to 4 MB is reserved as an internal ROM area.

<R>

##### (a) Internal ROM (512 KB)

512 KB are allocated to addresses 00000000H to 0007FFFFH in the following versions.

Accessing addresses 00080000H to 003FFFFFFH is prohibited.

- $\mu$ PD70F3931 (V850E/SJ3-H), 70F3932 (V850E/SJ3-H), 70F3933 (V850E/SJ3-H)

**Figure 3-4. Internal ROM Area (512 KB)**

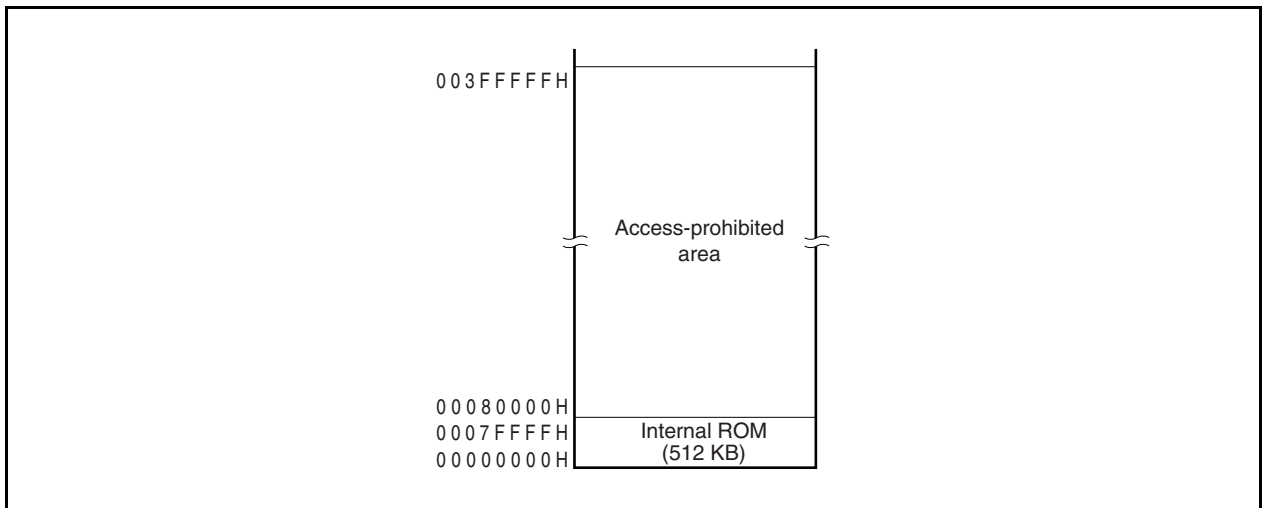

<R>

**(b) Internal ROM (768 KB)**

768 KB are allocated to addresses 00000000H to 000BFFFFH in the following versions.  
 Accessing addresses 000C0000H to 003FFFFFFH is prohibited.

- $\mu$ PD70F3934 (V850E/SJ3-H), 70F3935 (V850E/SJ3-H), 70F3936 (V850E/SJ3-H)

**Figure 3-5. Internal ROM Area (768 KB)**

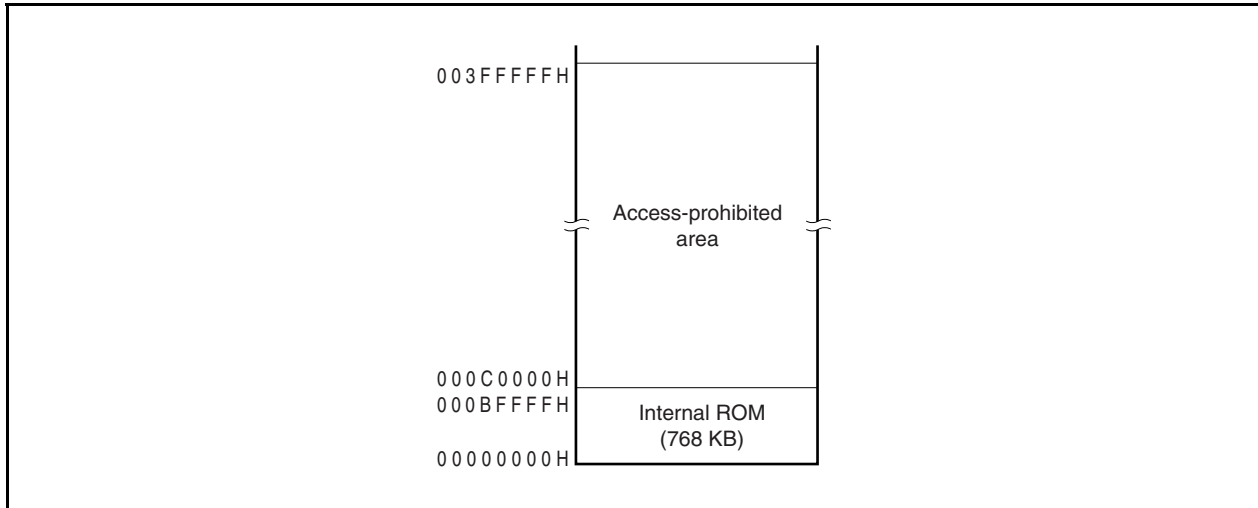

**(c) Internal ROM (1024 KB)**

1024 KB are allocated to addresses 00000000H to 000FFFFFFH in the following versions.  
 Accessing addresses 00100000H to 003FFFFFFH is prohibited.

- $\mu$ PD70F3925 (V850E/SK3-H), 70F3926 (V850E/SK3-H), 70F3927 (V850E/SK3-H),  
 70F3937 (V850E/SJ3-H), 70F3938 (V850E/SJ3-H), 70F3939 (V850E/SJ3-H)

<R>

**Figure 3-6. Internal ROM Area (1024 KB)**

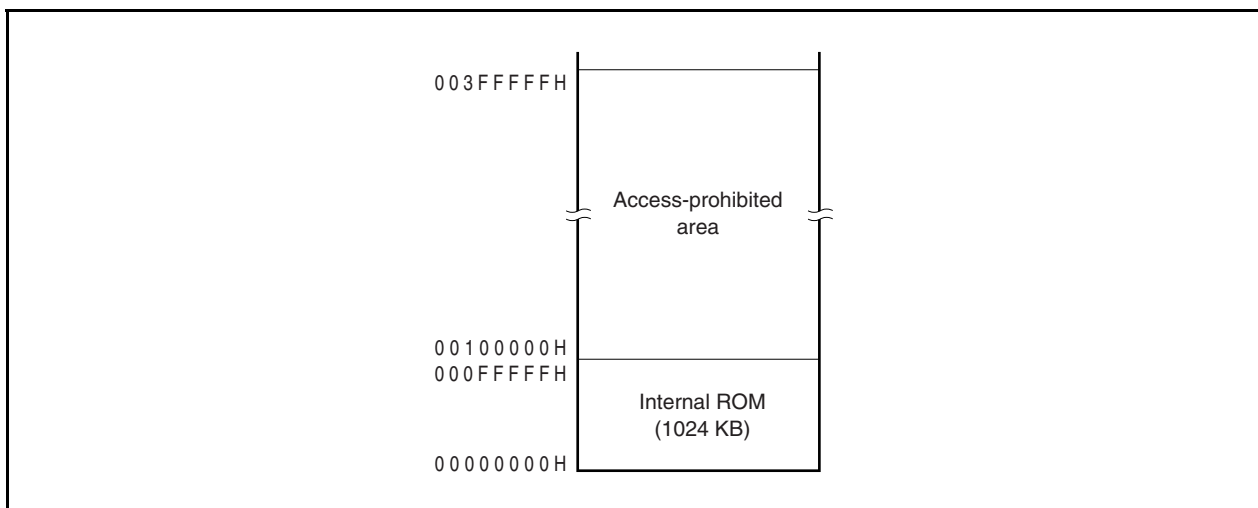

**(d) Internal ROM (1280 KB)**

1280 KB are allocated to addresses 00000000H to 0013FFFFH in the following versions.  
 Accessing addresses 00140000H to 003FFFFFFH is prohibited.

- $\mu$ PD70F3474 (V850E/SJ3-H), 70F3475 (V850E/SJ3-H), 70F3476 (V850E/SJ3-H),  
 70F3486 (V850E/SK3-H), 70F3487 (V850E/SK3-H), 70F3488 (V850E/SK3-H)

**Figure 3-7. Internal ROM Area (1280 KB)**

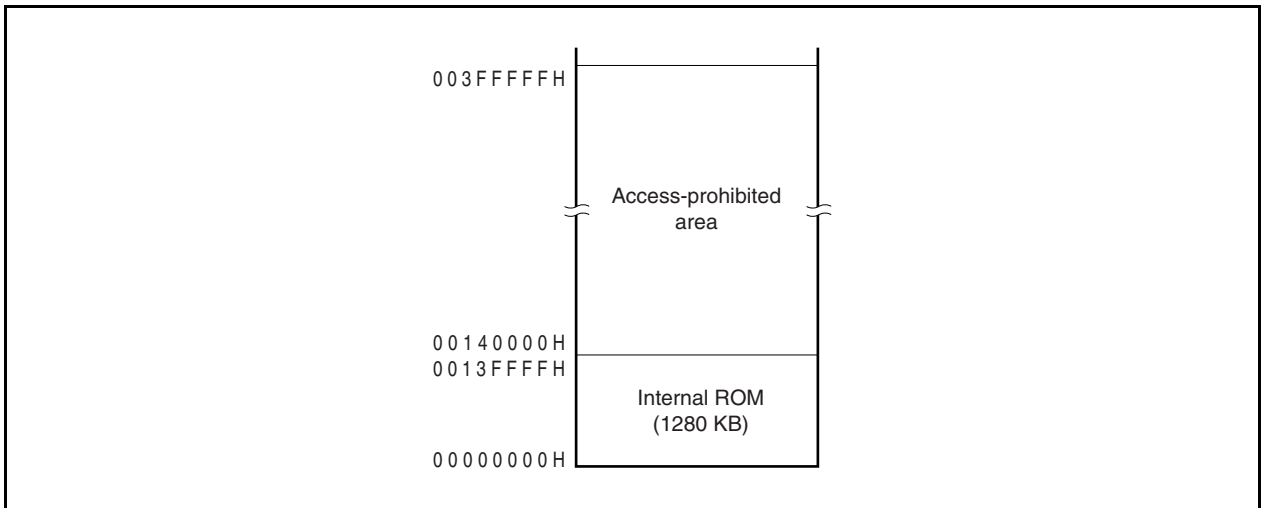

**(e) Internal ROM (1536 KB)**

1536 KB are allocated to addresses 00000000H to 0017FFFFH in the following versions.  
 Accessing addresses 00180000H to 003FFFFFFH is prohibited.

- $\mu$ PD70F3477 (V850E/SJ3-H), 70F3478 (V850E/SJ3-H), 70F3479 (V850E/SJ3-H),  
 70F3480 (V850E/SK3-H), 70F3481 (V850E/SK3-H), 70F3482 (V850E/SK3-H)

**Figure 3-8. Internal ROM Area (1536 KB)**

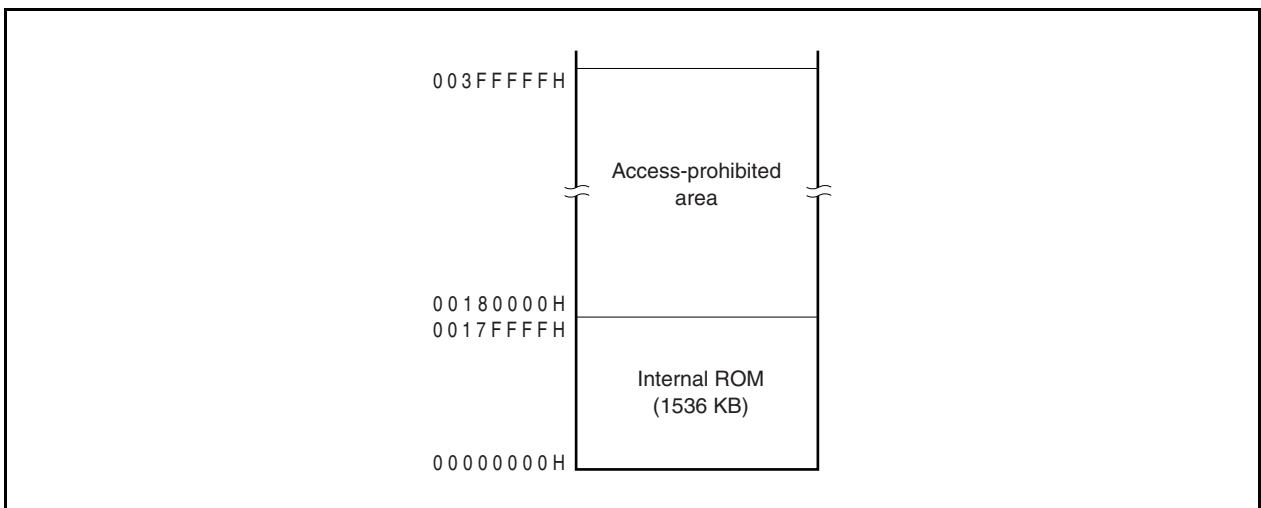

**(2) Internal RAM area**

60 KB are allocated to addresses 03FF0000H to 03FF0000H in the internal RAM area.

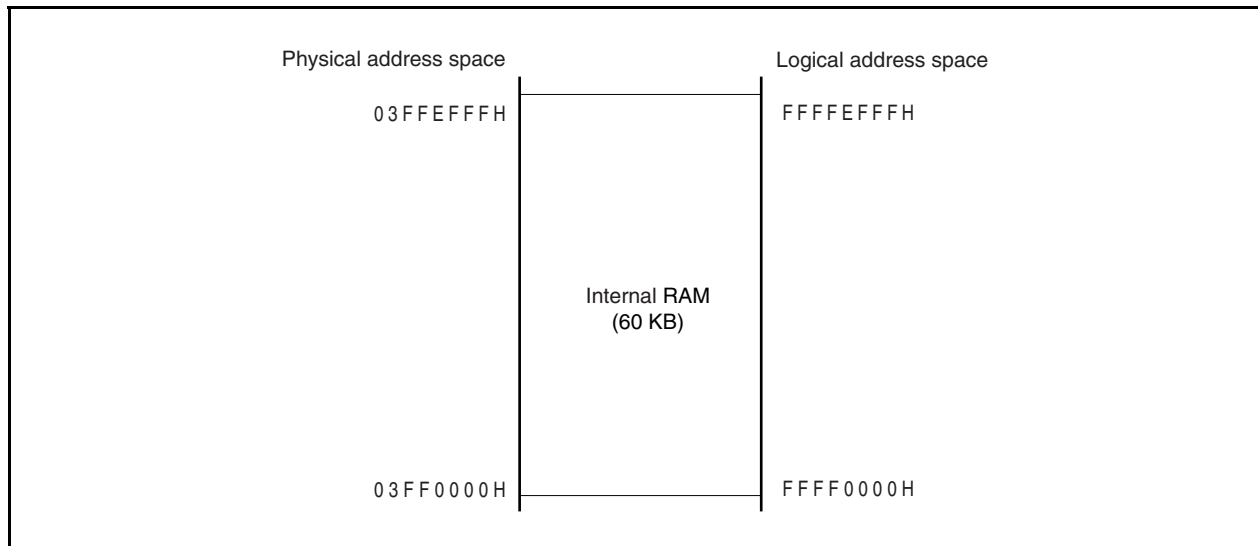
**Figure 3-9. Internal RAM Area (60 KB)**



**(3) On-chip peripheral I/O area**

4 KB of addresses 03FFF000H to 03FFFFFFH are reserved as the on-chip peripheral I/O area.

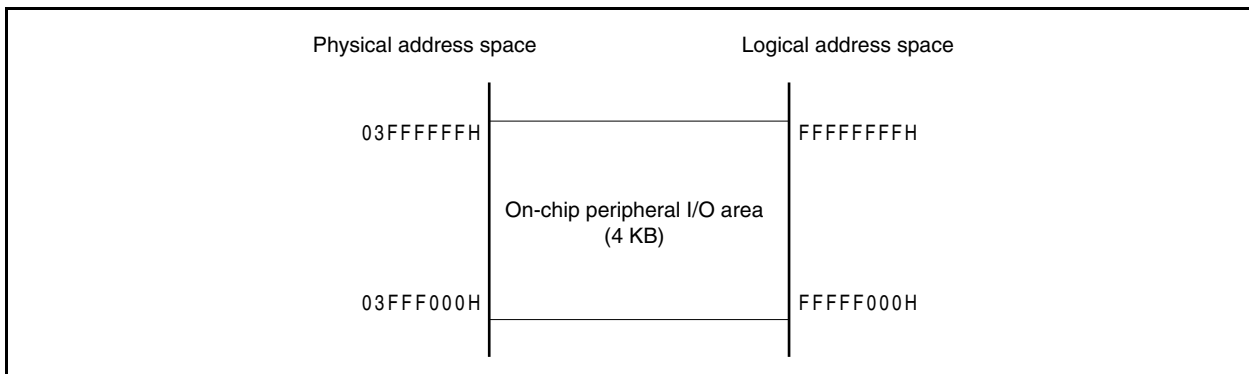
**Figure 3-10. On-Chip Peripheral I/O Area**

Peripheral I/O registers that have functions to specify the operation mode for and monitor the status of the on-chip peripheral I/O are mapped to the on-chip peripheral I/O area. Program cannot be fetched from this area.

- Cautions**
1. When a register is accessed in word units, a word area is accessed twice in halfword units in the order of lower area and higher area, with the lower 2 bits of the address ignored.
  2. If a register that can be accessed in byte units is accessed in halfword units, the higher 8 bits are undefined when the register is read, and data is written to the lower 8 bits.
  3. Addresses not defined as registers are reserved for future expansion. The operation is undefined and not guaranteed when these addresses are accessed.
  4. The internal ROM/RAM area and on-chip peripheral I/O area are assigned to successive addresses. When accessing the internal ROM/RAM area by incrementing or decrementing addresses using pointer operations and such, therefore, be careful not to access the on-chip peripheral I/O area by mistakenly extending over the internal ROM/RAM area boundary.

**(4) Programmable peripheral I/O area**

- Cautions**
1. The programmable peripheral I/O area exists only in the CAN controller versions. This area cannot be used with products that are not equipped with the CAN controller.
  2. Only the programmable peripheral I/O area is seen as images of 256 MB each in the 4 GB address space.

12 KB of addresses 03FEC000H to 03FEEFFFH are reserved as the programmable peripheral I/O area.

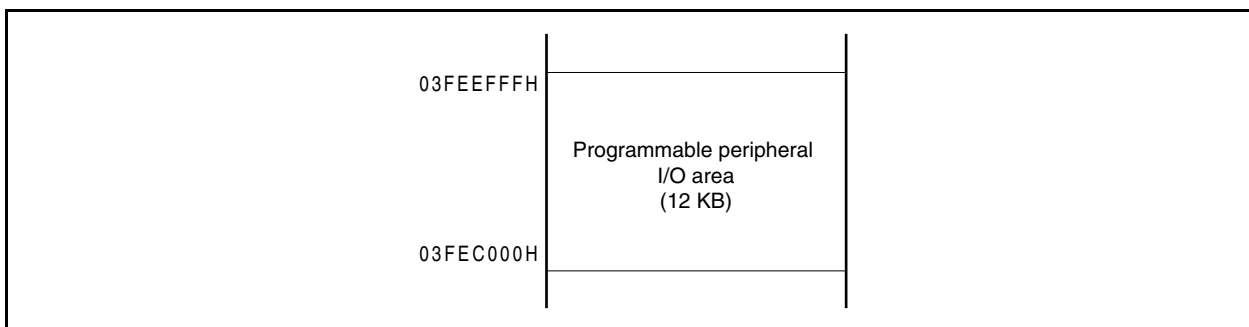
**Figure 3-11. Programmable Peripheral I/O Area**

**(5) External memory area**

<R> Up to 30 MB (00400000H to 01FFFFFFH, 03E00000H to 03FEBFFFH) are allocated as the external memory area. For details, see **CHAPTER 5 BUS CONTROL FUNCTION**.

**(6) Expanded internal RAM area**

The 32 KB area from addresses 03FE4000H to 03FEBFFFH is reserved as an expanded internal RAM area. The expanded internal RAM area is accessed via the external bus interface. Before accessing the expanded internal RAM area, be sure to set the registers related to the external bus interface (initialization of the expanded internal RAM).

- <R> **Remarks** 1. The following products are not provided with expanded internal RAM.
- $\mu$ PD70F3931 (V850E/SJ3-H), 70F3932 (V850E/SJ3-H), 70F3933 (V850E/SJ3-H)
- <R> 2. Expanded internal RAM area can be used as external memory area. For details, see **CHAPTER 5 BUS CONTROL FUNCTION**.

- Cautions** 1. When using the external memory and expanded internal RAM simultaneously, set the external bus interface and expanded internal RAM at the same time.
2. When accessing the expanded internal RAM, all the external bus interface control signals except the CS<sub>n</sub> signal become active (n = 1 to 3). Therefore, when using the expanded internal RAM and external memory at the same time, be sure to control access to the external memory by using the CS<sub>n</sub> signal output from the chip.
3. If an external wait is inserted via the WAIT pin, an external wait will also be inserted into expanded internal RAM access.
4. Be sure to specify the initial settings for the expanded internal RAM before using it.

**(a) Expanded internal RAM (16 KB)**

16 KB are allocated to addresses 03FE8000H to 03FEBFFFH in the following versions. Accessing addresses 03FE4000H to 03FE7FFFH is prohibited.

- $\mu$ PD70F3925 (V850E/SK3-H), 70F3926 (V850E/SK3-H), 70F3927 (V850E/SK3-H), 70F3934 (V850E/SJ3-H), 70F3935 (V850E/SJ3-H), 70F3936 (V850E/SJ3-H), 70F3937 (V850E/SJ3-H), 70F3938 (V850E/SJ3-H), 70F3939 (V850E/SJ3-H)

**Figure 3-12. Expanded Internal RAM Area (16 KB)**

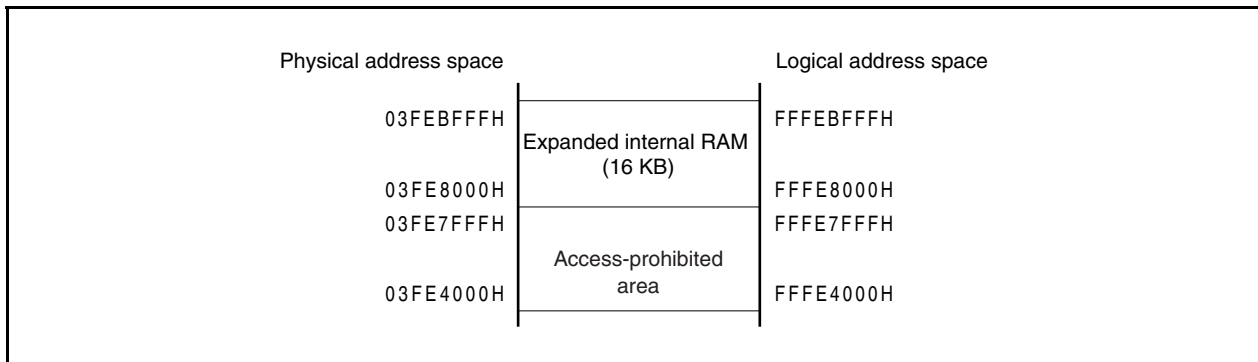

**(b) Expanded internal RAM (32 KB)**

32 KB are allocated to addresses 03FE4000H to 03FEBFFFH in the following versions.

- $\mu$ PD70F3474 (V850E/SJ3-H), 70F3475 (V850E/SJ3-H), 70F3476 (V850E/SJ3-H), 70F3477 (V850E/SJ3-H), 70F3478 (V850E/SJ3-H), 70F3479 (V850E/SJ3-H), 70F3480 (V850E/SK3-H), 70F3481 (V850E/SK3-H), 70F3482 (V850E/SK3-H), 70F3486 (V850E/SK3-H), 70F3487 (V850E/SK3-H), 70F3488 (V850E/SK3-H)

**Figure 3-13. Expanded Internal RAM Area (32 KB)**

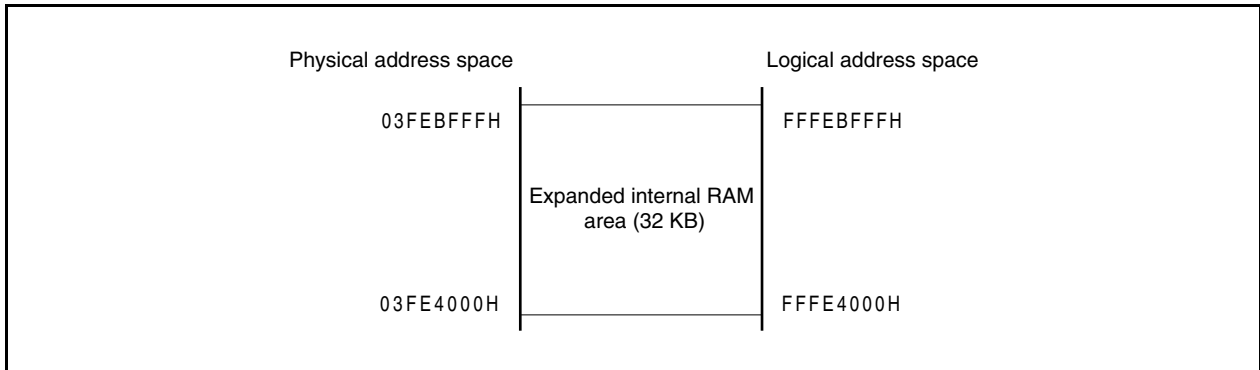
**(c) Features of expanded internal RAM**

- Can be accessed in as few as three bus cycles
- 32-bit data bus
- Misaligned access possible

**(d) Initial settings for expanded internal RAM**

The initial settings for the expanded internal RAM are shown below.

**Caution** If the expanded internal RAM is used with any but the following initial settings, operation is not guaranteed.

- BSC register setting  
Bits 15 to 8 must be set to 10010101.
- DWC1 register setting  
Set the values of the DWC1 register as follows, in accordance with the setting of the EXIMC register.

EXIMC Register Setting	DWC1 Register Setting
00H (Multiplexed bus mode)	0777H
01H (Separate bus mode)	1777H

- AWC register setting  
Bits 15 to 8 must be set to 00111111.
- BCC register setting  
Bits 15 to 8 must be set to 00101010.

**(7) Product selection register (PRDSEL)**

The PRDSEL register is a register to identify the product name and the internal RAM area.

This register is used divided into two 16-bit registers, PRDSELH and PRDSELL.

This register is read-only, in 16-bit units.

After reset: Depends on product    R    Address: PRDSELL FFFFCC8H, PRDSELH FFFFCCA8H

	15	14	13	12	11	10	9	8	7	6	5	4	3	2	1	0
PRDSELH	x	x	x	x	x	x	x	x	x	x	x	x	RAM3	RAM2	RAM1	RAM0

	15	14	13	12	11	10	9	8	7	6	5	4	3	2	1	0
PRDSELL	Product name (Last 3 digits)												x	x	x	x

RAM3 to RAM0	RAM Start Address
1010 <sup>Note 1</sup>	03FF0000H
1011 <sup>Note 2</sup>	

<R>

<R>

**Notes 1.**  $\mu$ PD70F3931 (V850E/SJ3-H), 70F3932 (V850E/SJ3-H), and 70F3933 (V850E/SJ3-H) only  
**2.** Other than  $\mu$ PD70F3931 (V850E/SJ3-H), 70F3932 (V850E/SJ3-H), and 70F3933 (V850E/SJ3-H)

**Caution** This register cannot be read by the in-circuit emulator (QB-V850ESX3H) (an undefined value is read).

**Remarks 1.** See Table 3-3 for product name setting examples.  
**2.** X: Undefined value

**Table 3-3. Product Name Setting Examples (1/2)**

Product Name	PRDSELL Register											
	Bit 15	Bit 14	Bit 13	Bit 12	Bit 11	Bit 10	Bit 9	Bit 8	Bit 7	Bit 6	Bit 5	Bit 4
$\mu$ PD70F3474	0	1	0	0	0	1	1	1	0	1	0	0
$\mu$ PD70F3475	0	1	0	0	0	1	1	1	0	1	0	1
$\mu$ PD70F3476	0	1	0	0	0	1	1	1	0	1	1	0
$\mu$ PD70F3477	0	1	0	0	0	1	1	1	0	1	1	1
$\mu$ PD70F3478	0	1	0	0	0	1	1	1	1	0	0	0
$\mu$ PD70F3479	0	1	0	0	0	1	1	1	1	0	0	1
$\mu$ PD70F3480	0	1	0	0	1	0	0	0	0	0	0	0
$\mu$ PD70F3481	0	1	0	0	1	0	0	0	0	0	0	1
$\mu$ PD70F3482	0	1	0	0	1	0	0	0	0	0	1	0
$\mu$ PD70F3486	0	1	0	0	1	0	0	0	0	1	1	0
$\mu$ PD70F3487	0	1	0	0	1	0	0	0	0	1	1	1
$\mu$ PD70F3488	0	1	0	0	1	0	0	0	1	0	0	0
$\mu$ PD70F3925	1	0	0	1	0	0	1	0	0	1	0	1
$\mu$ PD70F3926	1	0	0	1	0	0	1	0	0	1	1	0
$\mu$ PD70F3927	1	0	0	1	0	0	1	0	0	1	1	1

Table 3-3. Product Name Setting Examples (2/2)

Product Name	PRDSELL Register											
	Bit 15	Bit 14	Bit 13	Bit 12	Bit 11	Bit 10	Bit 9	Bit 8	Bit 7	Bit 6	Bit 5	Bit 4
<R> $\mu$ PD70F3 <u>931</u>	1	0	0	1	0	0	1	1	0	0	0	1
<R> $\mu$ PD70F3 <u>932</u>	1	0	0	1	0	0	1	1	0	0	1	0
<R> $\mu$ PD70F3 <u>933</u>	1	0	0	1	0	0	1	1	0	0	1	1
<R> $\mu$ PD70F3 <u>934</u>	1	0	0	1	0	0	1	1	0	1	0	0
<R> $\mu$ PD70F3 <u>935</u>	1	0	0	1	0	0	1	1	0	1	0	1
<R> $\mu$ PD70F3 <u>936</u>	1	0	0	1	0	0	1	1	0	1	1	0
<R> $\mu$ PD70F3 <u>937</u>	1	0	0	1	0	0	1	1	0	1	1	1
<R> $\mu$ PD70F3 <u>938</u>	1	0	0	1	0	0	1	1	1	0	0	0
<R> $\mu$ PD70F3 <u>939</u>	1	0	0	1	0	0	1	1	1	0	0	1

### 3.4.5 Recommended use of address space

The architecture of the V850E/SJ3-H and V850E/SK3-H requires that a register that serves as a pointer be secured for address generation when operand data in the data space is accessed. The address stored in this pointer  $\pm 32$  KB can be directly accessed by an instruction for operand data. Because the number of general-purpose registers that can be used as a pointer is limited, however, by keeping the performance from dropping during address calculation when a pointer value is changed, as many general-purpose registers as possible can be secured for variables, and the program size can be reduced.

#### (1) Program space

Of the 32 bits of the PC (program counter), the higher 6 bits are fixed to 0, and only the lower 26 bits are valid. Regarding the program space, therefore, a 64 MB space of contiguous addresses starting from 00000000H unconditionally corresponds to the memory map.

To use the internal RAM area as the program space, access the addresses 03FF0000H to 03FFEFFFH.

**Caution** If a branch instruction is at the upper limit of the internal RAM area, a prefetch operation (invalid fetch) straddling the on-chip peripheral I/O area does not occur.

**(2) Data space**

With the V850E/SJ3-H and V850E/SK3-H, it seems that there are sixty-four 64 MB address spaces on the 4 GB CPU address space. Therefore, the least significant bit (bit 25) of a 26-bit address is sign-extended to 32 bits and allocated as an address.

**(a) Application example of wraparound**

If R = r0 (zero register) is specified for the LD/ST disp16 [R] instruction, a range of addresses 00000000H  $\pm$ 32 KB can be addressed by sign-extended disp16. All the resources, including the internal hardware, can be addressed by one pointer.

The zero register (r0) is a register fixed to 0 by hardware, and practically eliminates the need for registers dedicated to pointers.

**Example:**  $\mu$ PD70F3474 (V850E/SJ3-H), 70F3475 (V850E/SJ3-H), 70F3476 (V850E/SJ3-H)

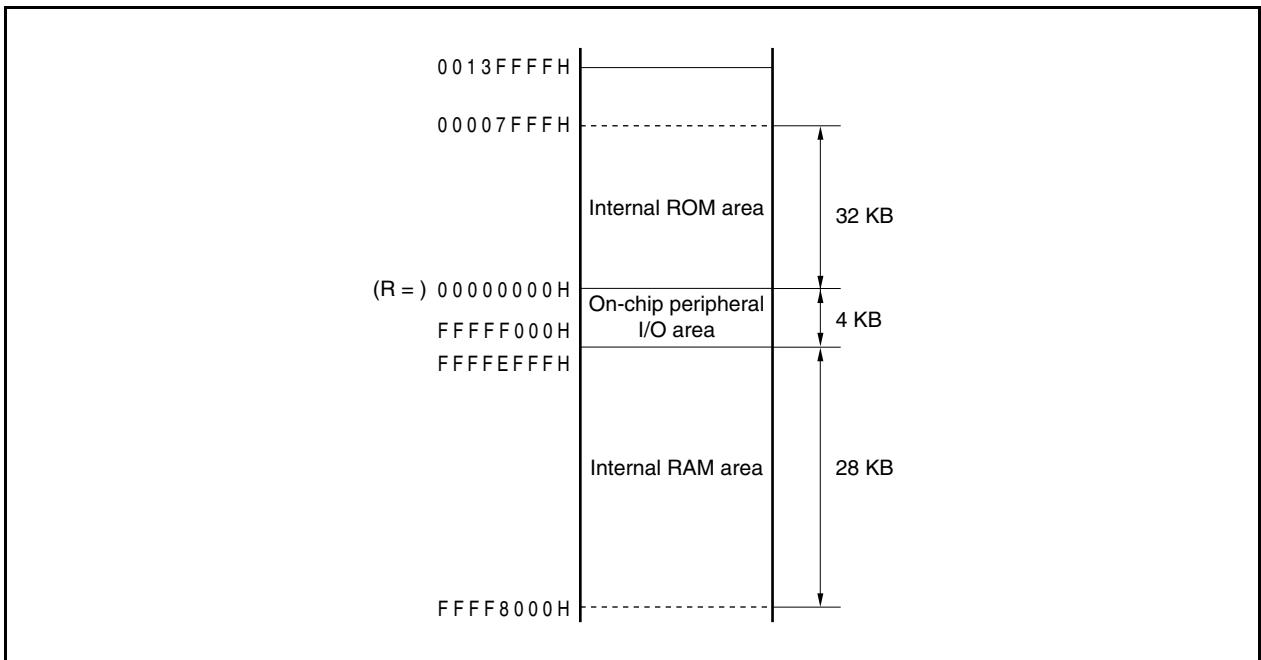
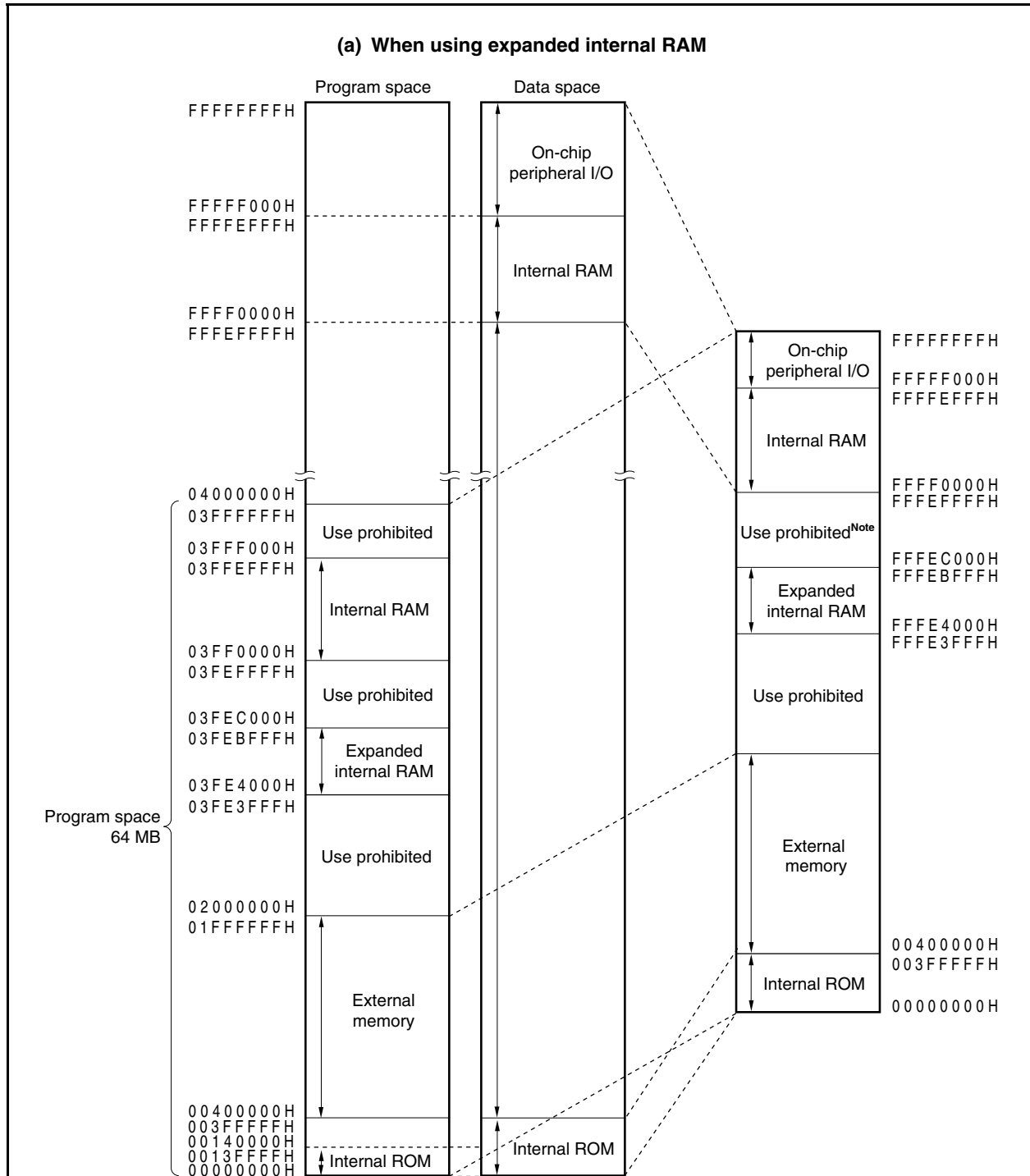

Figure 3-14. Recommended Memory Map (1/2)



**Note** In the CAN controller version, the data space of addresses 03FEC000H to 03FEEFFFH is assigned as the programmable peripheral I/O area. Only the programmable peripheral I/O area is seen as images of 256 MB each in the 4 GB address space.

- Remarks**
1. † indicates the recommended area.
  2. This figure is the recommended memory map when the expanded internal RAM of the  $\mu$ PD70F3474 (V850E/SJ3-H) is used (see 5.3.1 Chip select control function).



Figure 3-14. Recommended Memory Map (2/2)

<R>

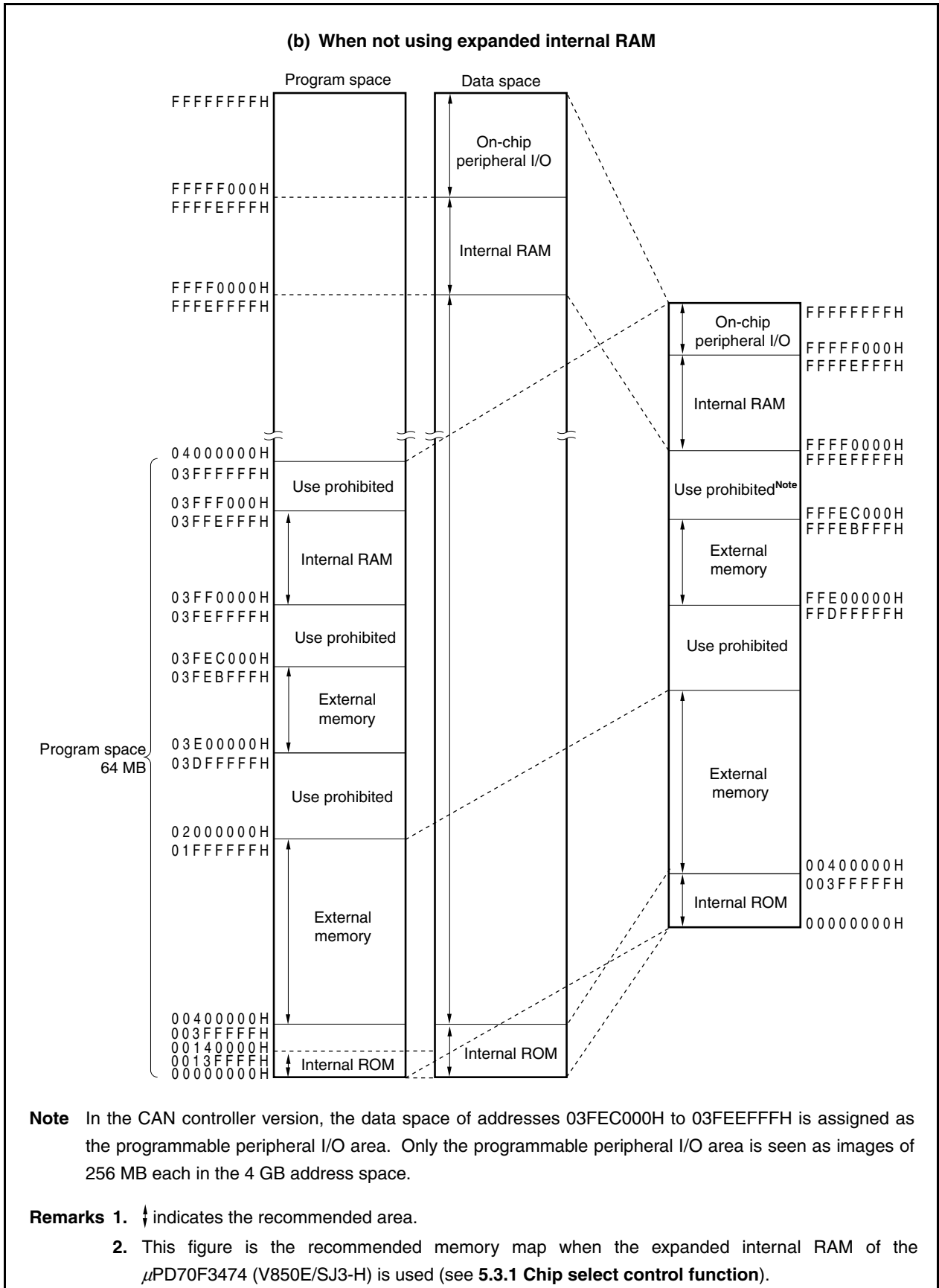

## 3.4.6 Peripheral I/O registers

(1/19)

Address	Function Register Name	Symbol	R/W	Manipulatable Bits			Default Value
				1	8	16	
FFFFF004H	Port DL register	PDL	R/W			√	0000H <sup>Note 1</sup>
FFFFF004H	Port DLL register	PDLL		√	√		00H <sup>Note 1</sup>
FFFFF005H	Port DLH register	PDLH		√	√		00H <sup>Note 1</sup>
FFFFF006H	Port DH register	PDH		√	√		00H <sup>Note 1</sup>
FFFFF008H	Port CS register	PCS		√	√		00H <sup>Note 1</sup>
FFFFF00AH	Port CT register	PCT		√	√		00H <sup>Note 1</sup>
FFFFF00CH	Port CM register	PCM		√	√		00H <sup>Note 1</sup>
FFFFF00EH	Port CD register	PCD		√	√		00H <sup>Note 1</sup>
FFFFF024H	Port DL mode register	PMDL				√	FFFFH
FFFFF024H	Port DL mode register L	PMDLL		√	√		FFH
FFFFF025H	Port DL mode register H	PMDLH		√	√		FFH
FFFFF026H	Port DH mode register	PMDH		√	√		FFH
FFFFF028H	Port CS mode register	PMCS		√	√		FFH
FFFFF02AH	Port CT mode register	PMCT		√	√		FFH
FFFFF02CH	Port CM mode register	PMCM		√	√		FFH
FFFFF02EH	Port CD mode register	PMCD		√	√		FFH
FFFFF044H	Port DL mode control register	PMCDL				√	0000H
FFFFF044H	Port DL mode control register L	PMCDLL		√	√		00H
FFFFF045H	Port DL mode control register H	PMCDLH		√	√		00H
FFFFF046H	Port DH mode control register	PMCDH		√	√		00H
FFFFF048H	Port CS mode control register	PMCCS		√	√		00H
FFFFF04AH	Port CT mode control register	PMCCT		√	√		00H
FFFFF04CH	Port CM mode control register	PMCCM		√	√		00H
FFFFF04EH	Port CD mode control register	PMCCD		√	√		00H
FFFFF04FH	Port CD function control register	PFCCD	√	√		00H	
FFFFF060H	Chip area select control register 0	CSC0			√	2C11H	
FFFFF062H	Chip area select control register 1	CSC1			√	2C11H	
FFFFF064H	Peripheral I/O area select control register	BPC <sup>Note 2</sup>			√	0000H	
FFFFF066H	Bus size configuration register	BSC			√	5555H	
FFFFF06EH	System wait control register	VSWC		√		77H	
FFFFF080H	DMA source address register 0L	DSA0L			√	Undefined	
FFFFF082H	DMA source address register 0H	DSA0H			√	Undefined	
FFFFF084H	DMA destination address register 0L	DDA0L			√	Undefined	
FFFFF086H	DMA destination address register 0H	DDA0H			√	Undefined	
FFFFF088H	DMA source address register 1L	DSA1L			√	Undefined	
FFFFF08AH	DMA source address register 1H	DSA1H			√	Undefined	
FFFFF08CH	DMA destination address register 1L	DDA1L			√	Undefined	
FFFFF08EH	DMA destination address register 1H	DDA1H			√	Undefined	
FFFFF090H	DMA source address register 2L	DSA2L			√	Undefined	
FFFFF092H	DMA source address register 2H	DSA2H			√	Undefined	

&lt;R&gt;

**Notes** 1. The value of the output latch is 00H or 0000H. The status of the pin is read during input.

2. CAN controller version only

Address	Function Register Name	Symbol	R/W	Manipulatable Bits			Default Value
				1	8	16	
FFFFF094H	DMA destination address register 2L	DDA2L	R/W			√	Undefined
FFFFF096H	DMA destination address register 2H	DDA2H				√	Undefined
FFFFF098H	DMA source address register 3L	DSA3L				√	Undefined
FFFFF09AH	DMA source address register 3H	DSA3H				√	Undefined
FFFFF09CH	DMA destination address register 3L	DDA3L				√	Undefined
FFFFF09EH	DMA destination address register 3H	DDA3H				√	Undefined
FFFFF0C0H	DMA transfer count register 0	DBC0				√	Undefined
FFFFF0C2H	DMA transfer count register 1	DBC1				√	Undefined
FFFFF0C4H	DMA transfer count register 2	DBC2				√	Undefined
FFFFF0C6H	DMA transfer count register 3	DBC3				√	Undefined
FFFFF0D0H	DMA addressing control register 0	DADC0				√	0000H
FFFFF0D2H	DMA addressing control register 1	DADC1				√	0000H
FFFFF0D4H	DMA addressing control register 2	DADC2				√	0000H
FFFFF0D6H	DMA addressing control register 3	DADC3				√	0000H
FFFFF0E0H	DMA channel control register 0	DCHC0		√	√		00H
FFFFF0E2H	DMA channel control register 1	DCHC1		√	√		00H
FFFFF0E4H	DMA channel control register 2	DCHC2		√	√		00H
FFFFF0E6H	DMA channel control register 3	DCHC3		√	√		00H
FFFFF100H	Interrupt mask register 0	IMR0				√	FFFFH
FFFFF100H	Interrupt mask register 0L	IMR0L		√	√		FFH
FFFFF101H	Interrupt mask register 0H	IMR0H	√	√		FFH	
FFFFF102H	Interrupt mask register 1	IMR1			√	FFFFH	
FFFFF102H	Interrupt mask register 1L	IMR1L	√	√		FFH	
FFFFF103H	Interrupt mask register 1H	IMR1H	√	√		FFH	
FFFFF104H	Interrupt mask register 2	IMR2			√	FFFFH	
FFFFF104H	Interrupt mask register 2L	IMR2L	√	√		FFH	
FFFFF105H	Interrupt mask register 2H	IMR2H	√	√		FFH	
FFFFF106H	Interrupt mask register 3	IMR3			√	FFFFH	
FFFFF106H	Interrupt mask register 3L	IMR3L	√	√		FFH	
FFFFF107H	Interrupt mask register 3H	IMR3H	√	√		FFH	
FFFFF108H	Interrupt mask register 4	IMR4			√	FFFFH	
FFFFF108H	Interrupt mask register 4L	IMR4L	√	√		FFH	
FFFFF109H	Interrupt mask register 4H	IMR4H	√	√		FFH	
FFFFF10AH	Interrupt mask register 5	IMR5			√	FFFFH	
FFFFF10AH	Interrupt mask register 5L	IMR5L	√	√		FFH	
FFFFF10BH	Interrupt mask register 5H	IMR5H	√	√		FFH	
FFFFF10CH	Interrupt mask register 6	IMR6			√	FFFFH	
FFFFF10CH	Interrupt mask register 6L	IMR6L	√	√		FFH	
FFFFF10DH	Interrupt mask register 6H	IMR6H	√	√		FFH	
FFFFF10EH	Interrupt mask register 7L	IMR7L	√	√		1FH	
FFFFF110H	Interrupt control register	LVIIC	√	√		47H	
FFFFF112H	Interrupt control register	PIC0	√	√		47H	

Address	Function Register Name	Symbol	R/W	Manipulatable Bits			Default Value
				1	8	16	
FFFFF114H	Interrupt control register	PIC1	R/W	√	√		47H
FFFFF116H	Interrupt control register	PIC2		√	√		47H
FFFFF118H	Interrupt control register	PIC3		√	√		47H
FFFFF11AH	Interrupt control register	PIC4		√	√		47H
FFFFF11CH	Interrupt control register	PIC5		√	√		47H
FFFFF11EH	Interrupt control register	PIC6		√	√		47H
FFFFF120H	Interrupt control register	PIC7		√	√		47H
FFFFF122H	Interrupt control register	TQ0OVIC		√	√		47H
FFFFF124H	Interrupt control register	TQ0CCIC0		√	√		47H
FFFFF126H	Interrupt control register	TQ0CCIC1		√	√		47H
FFFFF128H	Interrupt control register	TQ0CCIC2		√	√		47H
FFFFF12AH	Interrupt control register	TQ0CCIC3		√	√		47H
FFFFF12CH	Interrupt control register	TP0OVIC		√	√		47H
FFFFF12EH	Interrupt control register	TP0CCIC0		√	√		47H
FFFFF130H	Interrupt control register	TP0CCIC1		√	√		47H
FFFFF132H	Interrupt control register	TP1OVIC		√	√		47H
FFFFF134H	Interrupt control register	TP1CCIC0		√	√		47H
FFFFF136H	Interrupt control register	TP1CCIC1		√	√		47H
FFFFF138H	Interrupt control register	TP2OVIC		√	√		47H
FFFFF13AH	Interrupt control register	TP2CCIC0		√	√		47H
FFFFF13CH	Interrupt control register	TP2CCIC1		√	√		47H
FFFFF13EH	Interrupt control register	TP3OVIC		√	√		47H
FFFFF140H	Interrupt control register	TP3CCIC0		√	√		47H
FFFFF142H	Interrupt control register	TP3CCIC1		√	√		47H
FFFFF144H	Interrupt control register	TP4OVIC		√	√		47H
FFFFF146H	Interrupt control register	TP4CCIC0		√	√		47H
FFFFF148H	Interrupt control register	TP4CCIC1		√	√		47H
FFFFF14AH	Interrupt control register	TP5OVIC		√	√		47H
FFFFF14CH	Interrupt control register	TP5CCIC0		√	√		47H
FFFFF14EH	Interrupt control register	TP5CCIC1		√	√		47H
FFFFF150H	Interrupt control register	TM0EQIC0		√	√		47H
FFFFF152H	Interrupt control register	CB0RIC/IICIC1		√	√		47H
FFFFF154H	Interrupt control register	CB0TIC	√	√		47H	
FFFFF156H	Interrupt control register	CB1RIC	√	√		47H	
FFFFF158H	Interrupt control register	CB1TIC	√	√		47H	
FFFFF15AH	Interrupt control register	CB2RIC	√	√		47H	
FFFFF15CH	Interrupt control register	CB2TIC	√	√		47H	
FFFFF15EH	Interrupt control register	CB3RIC	√	√		47H	
FFFFF160H	Interrupt control register	CB3TIC	√	√		47H	
FFFFF162H	Interrupt control register	UA0RIC/CB4RIC	√	√		47H	
FFFFF164H	Interrupt control register	UA0TIC/CB4TIC	√	√		47H	
FFFFF166H	Interrupt control register	UA1RIC	√	√		47H	

Address	Function Register Name	Symbol	R/W	Manipulatable Bits			Default Value
				1	8	16	
FFFFF168H	Interrupt control register	UA1TIC	R/W	√	√		47H
FFFFF16AH	Interrupt control register	UA2RIC		√	√		47H
FFFFF16CH	Interrupt control register	UA2TIC		√	√		47H
FFFFF16EH	Interrupt control register	ADIC		√	√		47H
FFFFF170H	Interrupt control register	DMAIC0		√	√		47H
FFFFF172H	Interrupt control register	DMAIC1		√	√		47H
FFFFF174H	Interrupt control register	DMAIC2		√	√		47H
FFFFF176H	Interrupt control register	DMAIC3		√	√		47H
FFFFF178H	Interrupt control register	KRIC		√	√		47H
FFFFF17AH	Interrupt control register	WTIIC		√	√		47H
FFFFF17CH	Interrupt control register	WTIC		√	√		47H
FFFFF17EH	Interrupt control register	ERRIC0 <sup>Note 1</sup>		√	√		47H
FFFFF180H	Interrupt control register	WUPIC0 <sup>Note 1</sup>		√	√		47H
FFFFF182H	Interrupt control register	RECIC0 <sup>Note 1</sup>		√	√		47H
FFFFF184H	Interrupt control register	TRXIC0 <sup>Note 1</sup>		√	√		47H
FFFFF186H	Interrupt control register	ERRIC1 <sup>Note 2</sup>		√	√		47H
FFFFF188H	Interrupt control register	WUPIC1 <sup>Note 2</sup>		√	√		47H
FFFFF18AH	Interrupt control register	RECIC1 <sup>Note 2</sup>		√	√		47H
FFFFF18CH	Interrupt control register	TRXIC1 <sup>Note 2</sup>		√	√		47H
FFFFF18EH	Interrupt control register	PIC8		√	√		47H
FFFFF190H	Interrupt control register	TP6OVIC		√	√		47H
FFFFF192H	Interrupt control register	TP6CCIC0		√	√		47H
FFFFF194H	Interrupt control register	TP6CCIC1		√	√		47H
FFFFF196H	Interrupt control register	TP7OVIC		√	√		47H
FFFFF198H	Interrupt control register	TP7CCIC0		√	√		47H
FFFFF19AH	Interrupt control register	TP7CCIC1		√	√		47H
FFFFF19CH	Interrupt control register	TP8OVIC		√	√		47H
FFFFF19EH	Interrupt control register	TP8CCIC0		√	√		47H
FFFFF1A0H	Interrupt control register	TP8CCIC1		√	√		47H
FFFFF1A2H	Interrupt control register	CB5RIC		√	√		47H
FFFFF1A4H	Interrupt control register	CB5TIC		√	√		47H
FFFFF1A6H	Interrupt control register	UA3RIC		√	√		47H
FFFFF1A8H	Interrupt control register	UA3TIC	√	√		47H	
FFFFF1B0H	Interrupt control register	UA4RIC	√	√		47H	
FFFFF1B2H	Interrupt control register	UA4TIC	√	√		47H	
FFFFF1B4H	Interrupt control register	IICIC3	√	√		47H	
FFFFF1B6H	Interrupt control register	IICIC0	√	√		47H	
FFFFF1B8H	Interrupt control register	IICIC2	√	√		47H	
FFFFF1BAH	Interrupt control register	IICIC4 <sup>Note 3</sup>	√	√		47H	
FFFFF1BCH	Interrupt control register	IICIC5 <sup>Note 3</sup>	√	√		47H	

**Notes** 1. CAN controller version only

2. CAN controller (2-channel) version only

3. Not available in the  $\mu$ PD70F3931 (V850E/SJ3-H), 70F3932 (V850E/SJ3-H), and 70F3933 (V850E/SJ3-H)

Address	Function Register Name	Symbol	R/W	Manipulatable Bits			Default Value	
				1	8	16		
FFFFF1BEH	Interrupt control register	PIC9	R/W	√	√		47H	
FFFFF1C0H	Interrupt control register	TP7IECIC		√	√		47H	
FFFFF1C2H	Interrupt control register	TP8IECIC		√	√		47H	
FFFFF1C4H	Interrupt control register	TM1EQIC0		√	√		47H	
FFFFF1C6H	Interrupt control register	TM2EQIC0		√	√		47H	
<R> FFFFF1C8H	Interrupt control register	CE0TIC <sup>Note</sup>		√	√		47H	
<R> FFFFF1CAH	Interrupt control register	CE0TIOFIC <sup>Note</sup>		√	√		47H	
<R> FFFFF1CCH	Interrupt control register	CE1TIC <sup>Note</sup>		√	√		47H	
<R> FFFFF1CEH	Interrupt control register	CE1TIOFIC <sup>Note</sup>		√	√		47H	
FFFFF1D0H	Interrupt control register	UB0TIRIC		√	√		47H	
FFFFF1D2H	Interrupt control register	UB0TITIC		√	√		47H	
FFFFF1D4H	Interrupt control register	UB0TIFIC		√	√		47H	
FFFFF1D6H	Interrupt control register	UB0TIREIC		√	√		47H	
FFFFF1D8H	Interrupt control register	UB0TIOIC		√	√		47H	
FFFFF1DAH	Interrupt control register	UB1TIRIC		√	√		47H	
FFFFF1DCH	Interrupt control register	UB1TITIC		√	√		47H	
FFFFF1DEH	Interrupt control register	UB1TIFIC		√	√		47H	
FFFFF1E0H	Interrupt control register	UB1TIREIC		√	√		47H	
FFFFF1E2H	Interrupt control register	UB1TIOIC		√	√		47H	
FFFFF1E4H	Interrupt control register	UA5RIC		√	√		47H	
FFFFF1E6H	Interrupt control register	UA5TIC		√	√		47H	
FFFFF1E8H	Interrupt control register	ERRIC		√	√		47H	
FFFFF1EAH	Interrupt control register	STAIC		√	√		47H	
FFFFF1ECH	Interrupt control register	IEIC1		√	√		47H	
FFFFF1EEH	Interrupt control register	IEIC2		√	√		47H	
FFFFF1F0H	Interrupt control register	RTC0IC		√	√		47H	
FFFFF1F2H	Interrupt control register	RTC1IC		√	√		47H	
FFFFF1F4H	Interrupt control register	RTC2IC	√	√		47H		
FFFFF1FAH	In-service priority register	ISPR	R	√	√		00H	
FFFFF1FCH	Command register	PRCMD	W		√		Undefined	
FFFFF1FEH	Power save control register	PSC	R/W	√	√		00H	
FFFFF200H	A/D converter mode register 0	ADA0M0		√	√		00H	
FFFFF201H	A/D converter mode register 1	ADA0M1		√	√		00H	
FFFFF202H	A/D converter channel specification register	ADA0S		√	√		00H	
FFFFF203H	A/D converter mode register 2	ADA0M2		√	√		00H	
FFFFF204H	Power-fail compare mode register	ADA0PFM		√	√		00H	
FFFFF205H	Power-fail compare threshold value register	ADA0PFT		√	√		00H	
FFFFF210H	A/D conversion result register 0	ADA0CR0		R			√	Undefined
FFFFF211H	A/D conversion result register 0H	ADA0CR0H				√		Undefined
FFFFF212H	A/D conversion result register 1	ADA0CR1				√	Undefined	
FFFFF213H	A/D conversion result register 1H	ADA0CR1H			√		Undefined	

<R> **Note** Not available in the  $\mu$ PD70F3931 (V850E/SJ3-H), 70F3932 (V850E/SJ3-H), and 70F3933 (V850E/SJ3-H)

Address	Function Register Name	Symbol	R/W	Manipulatable Bits			Default Value	
				1	8	16		
FFFFF214H	A/D conversion result register 2	ADA0CR2	R			√	Undefined	
FFFFF215H	A/D conversion result register 2H	ADA0CR2H			√		Undefined	
FFFFF216H	A/D conversion result register 3	ADA0CR3				√	Undefined	
FFFFF217H	A/D conversion result register 3H	ADA0CR3H			√		Undefined	
FFFFF218H	A/D conversion result register 4	ADA0CR4				√	Undefined	
FFFFF219H	A/D conversion result register 4H	ADA0CR4H			√		Undefined	
FFFFF21AH	A/D conversion result register 5	ADA0CR5				√	Undefined	
FFFFF21BH	A/D conversion result register 5H	ADA0CR5H			√		Undefined	
FFFFF21CH	A/D conversion result register 6	ADA0CR6				√	Undefined	
FFFFF21DH	A/D conversion result register 6H	ADA0CR6H			√		Undefined	
FFFFF21EH	A/D conversion result register 7	ADA0CR7				√	Undefined	
FFFFF21FH	A/D conversion result register 7H	ADA0CR7H			√		Undefined	
FFFFF220H	A/D conversion result register 8	ADA0CR8				√	Undefined	
FFFFF221H	A/D conversion result register 8H	ADA0CR8H			√		Undefined	
FFFFF222H	A/D conversion result register 9	ADA0CR9				√	Undefined	
FFFFF223H	A/D conversion result register 9H	ADA0CR9H			√		Undefined	
FFFFF224H	A/D conversion result register 10	ADA0CR10				√	Undefined	
FFFFF225H	A/D conversion result register 10H	ADA0CR10H			√		Undefined	
FFFFF226H	A/D conversion result register 11	ADA0CR11				√	Undefined	
FFFFF227H	A/D conversion result register 11H	ADA0CR11H			√		Undefined	
FFFFF228H	A/D conversion result register 12	ADA0CR12				√	Undefined	
FFFFF229H	A/D conversion result register 12H	ADA0CR12H			√		Undefined	
FFFFF22AH	A/D conversion result register 13	ADA0CR13				√	Undefined	
FFFFF22BH	A/D conversion result register 13H	ADA0CR13H			√		Undefined	
FFFFF22CH	A/D conversion result register 14	ADA0CR14				√	Undefined	
FFFFF22DH	A/D conversion result register 14H	ADA0CR14H			√		Undefined	
FFFFF22EH	A/D conversion result register 15	ADA0CR15				√	Undefined	
FFFFF22FH	A/D conversion result register 15H	ADA0CR15H			√		Undefined	
FFFFF280H	D/A converter conversion value setting register 0	DA0CS0		R/W		√		00H
FFFFF281H	D/A converter conversion value setting register 1	DA0CS1				√		00H
FFFFF282H	D/A converter mode register	DA0M	√		√		00H	
FFFFF300H	Key return mode register	KRM	√		√		00H	
FFFFF308H	Selector operation control register 0	SELCNT0	√		√		00H	
FFFFF310H	CRC input register	CRCIN			√		00H	
FFFFF312H	CRC data register	CRCD				√	0000H	
FFFFF318H	Noise elimination control register	NFC			√		00H	
FFFFF31CH	TMP7 noise elimination control register	EN0NFC			√		00H	
FFFFF31EH	TMP8 noise elimination control register	EN1NFC			√		00H	
FFFFF320H	BRG1 prescaler mode register	PRSM1	√		√		00H	
FFFFF321H	BRG1 prescaler compare register	PRSCM1			√		00H	
FFFFF324H	BRG2 prescaler mode register	PRSM2	√		√		00H	
FFFFF325H	BRG2 prescaler compare register	PRSCM2			√		00H	

Address	Function Register Name	Symbol	R/W	Manipulatable Bits			Default Value
				1	8	16	
FFFFF328H	BRG3 prescaler mode register	PRSM3	R/W	√	√		00H
FFFFF329H	BRG3 prescaler compare register	PRSCM3			√		00H
FFFFF340H	IIC division clock select register 0	OCKS0			√		00H
FFFFF344H	IIC division clock select register 1	OCKS1			√		00H
FFFFF348H	IEBus clock select register	OCKS2			√		00H
<R> FFFFF34CH	IIC division clock select register 3	OCKS3 <sup>Note 1</sup>			√		00H
FFFFF360H	IEBus control register	BCR		√	√		00H
FFFFF361H	IEBus power save register	PSR		√	√		00H
FFFFF362H	IEBus slave status register	SSR	R	√	√		81H
FFFFF363H	IEBus unit status register	USR		√	√		00H
FFFFF364H	IEBus interrupt status register	ISR	R/W	√	√		00H
FFFFF365H	IEBus error status register	ESR		√	√		00H
FFFFF366H	IEBus unit address register	UAR				√	0000H
FFFFF368H	IEBus slave address register	SAR				√	0000H
FFFFF36AH	IEBus partner address register	PAR	R			√	0000H
FFFFF36CH	IEBus receive slave address register	RSA				√	0000H
FFFFF36EH	IEBus control data register	CDR	R/W		√		00H
FFFFF36FH	IEBus telegraph length register	DLR			√		01H
FFFFF370H	IEBus data register	DR			√		00H
FFFFF371H	IEBus field status register	FSR	R		√		00H
FFFFF372H	IEBus success count register	SCR			√		01H
FFFFF373H	IEBus communication count register	CCR			√		20H
FFFFF3F0H	SSCG control register	SSCGCTL	R/W	√	√		00H
FFFFF3F1H	SSCG frequency control register 0	SFC0			√		00H
FFFFF3F2H	SSCG frequency control register 1	SFC1			√		00H
FFFFF400H	Port 0 register	P0		√	√		00H <sup>Note 2</sup>
FFFFF402H	Port 1 register	P1		√	√		00H <sup>Note 2</sup>
FFFFF404H	Port 2 register	P2		√	√		00H <sup>Note 2</sup>
FFFFF406H	Port 3 register	P3				√	0000H <sup>Note 2</sup>
FFFFF406H	Port 3L register	P3L		√	√		00H <sup>Note 2</sup>
FFFFF407H	Port 3H register	P3H		√	√		00H <sup>Note 2</sup>
FFFFF408H	Port 4 register	P4		√	√		00H <sup>Note 2</sup>
FFFFF40AH	Port 5 register	P5		√	√		00H <sup>Note 2</sup>
FFFFF40CH	Port 6 register	P6				√	0000H <sup>Note 2</sup>
FFFFF40CH	Port 6L register	P6L		√	√		00H <sup>Note 2</sup>
FFFFF40DH	Port 6H register	P6H		√	√		00H <sup>Note 2</sup>
FFFFF40EH	Port 7L register	P7L		√	√		00H <sup>Note 2</sup>
FFFFF40FH	Port 7H register	P7H		√	√		00H <sup>Note 2</sup>
FFFFF410H	Port 8 register	P8		√	√		00H <sup>Note 2</sup>

- <R> **Notes** 1. Not available in the  $\mu$ PD70F3931 (V850E/SJ3-H), 70F3932 (V850E/SJ3-H), and 70F3933 (V850E/SJ3-H)  
 2. The value of the output latch is 00H or 0000H. The status of the pin is read during input.



Address	Function Register Name	Symbol	R/W	Manipulatable Bits			Default Value
				1	8	16	
FFFFF412H	Port 9 register	P9	R/W			√	0000H <sup>Note 1</sup>
FFFFF412H	Port 9L register	P9L		√	√		00H <sup>Note 1</sup>
FFFFF413H	Port 9H register	P9H		√	√		00H <sup>Note 1</sup>
FFFFF41AH	Port 13 register	P13 <sup>Note 2</sup>		√	√		00H <sup>Note 1</sup>
FFFFF41CH	Port 14 register	P14 <sup>Note 2</sup>		√	√		00H <sup>Note 1</sup>
FFFFF41EH	Port 15 register	P15 <sup>Note 2</sup>		√	√		00H <sup>Note 1</sup>
FFFFF420H	Port 0 mode register	PM0		√	√		FFH
FFFFF422H	Port 1 mode register	PM1		√	√		FFH
FFFFF424H	Port 2 mode register	PM2 <sup>Note</sup>		√	√		FFH
FFFFF426H	Port 3 mode register	PM3				√	FFFFH
FFFFF426H	Port 3 mode register L	PM3L		√	√		FFH
FFFFF427H	Port 3 mode register H	PM3H		√	√		FFH
FFFFF428H	Port 4 mode register	PM4		√	√		FFH
FFFFF42AH	Port 5 mode register	PM5		√	√		FFH
FFFFF42CH	Port 6 mode register	PM6				√	FFFFH
FFFFF42CH	Port 6 mode register L	PM6L		√	√		FFH
FFFFF42DH	Port 6 mode register H	PM6H		√	√		FFH
FFFFF42EH	Port 7 mode register L	PM7L		√	√		FFH
FFFFF42FH	Port 7 mode register H	PM7H		√	√		FFH
FFFFF430H	Port 8 mode register	PM8		√	√		FFH
FFFFF432H	Port 9 mode register	PM9				√	FFFFH
FFFFF432H	Port 9 mode register L	PM9L		√	√		FFH
FFFFF433H	Port 9 mode register H	PM9H		√	√		FFH
FFFFF43AH	Port 13 mode register	PM13 <sup>Note 2</sup>		√	√		FFH
FFFFF43CH	Port 14 mode register	PM14 <sup>Note 2</sup>		√	√		FFH
FFFFF43EH	Port 15 mode register	PM15 <sup>Note 2</sup>		√	√		FFH
FFFFF440H	Port 0 mode control register	PMC0		√	√		00H
FFFFF444H	Port 2 mode control register	PMC2 <sup>Note 2</sup>	√	√		00H	
FFFFF446H	Port 3 mode control register	PMC3			√	0000H	
FFFFF446H	Port 3 mode control register L	PMC3L	√	√		00H	
FFFFF447H	Port 3 mode control register H	PMC3H	√	√		00H	
FFFFF448H	Port 4 mode control register	PMC4	√	√		00H	
FFFFF44AH	Port 5 mode control register	PMC5	√	√		00H	
FFFFF44CH	Port 6 mode control register	PMC6			√	0000H	
FFFFF44CH	Port 6 mode control register L	PMC6L	√	√		00H	
FFFFF44DH	Port 6 mode control register H	PMC6H	√	√		00H	
FFFFF450H	Port 8 mode control register	PMC8	√	√		00H	
FFFFF452H	Port 9 mode control register	PMC9			√	0000H	
FFFFF452H	Port 9 mode control register L	PMC9L	√	√		00H	
FFFFF453H	Port 9 mode control register H	PMC9H	√	√		00H	

**Notes** 1. The value of the output latch is 00H or 0000H. The status of the pin is read during input.

2. V850E/SK3-H only

Address	Function Register Name	Symbol	R/W	Manipulatable Bits			Default Value
				1	8	16	
FFFFF45EH	Port 15 mode control register	PMC15 <sup>Note</sup>	R/W	√	√		00H
FFFFF460H	Port 0 function control register	PFC0		√	√		00H
FFFFF466H	Port 3 function control register	PFC3				√	0000H
FFFFF466H	Port 3 function control register L	PFC3L		√	√		00H
FFFFF467H	Port 3 function control register H	PFC3H		√	√		00H
FFFFF468H	Port 4 function control register	PFC4		√	√		00H
FFFFF46AH	Port 5 function control register	PFC5		√	√		00H
FFFFF46CH	Port 6 function control register	PFC6				√	0000H
FFFFF46CH	Port 6 function control register L	PFC6L		√	√		00H
FFFFF46DH	Port 6 function control register H	PFC6H		√	√		00H
FFFFF470H	Port 8 function control register	PFC8		√	√		00H
FFFFF472H	Port 9 function control register	PFC9				√	0000H
FFFFF472H	Port 9 function control register L	PFC9L		√	√		00H
FFFFF473H	Port 9 function control register H	PFC9H		√	√		00H
FFFFF484H	Data wait control register 0	DWC0				√	7777H
FFFFF486H	Data wait control register 1	DWC1				√	7777H
FFFFF488H	Address wait control register	AWC				√	FFFFH
FFFFF48AH	Bus cycle control register	BCC				√	AAAAH
FFFFF540H	TMQ0 control register 0	TQ0CTL0		√	√		00H
FFFFF541H	TMQ0 control register 1	TQ0CTL1		√	√		00H
FFFFF542H	TMQ0 I/O control register 0	TQ0IOC0		√	√		00H
FFFFF543H	TMQ0 I/O control register 1	TQ0IOC1		√	√		00H
FFFFF544H	TMQ0 I/O control register 2	TQ0IOC2		√	√		00H
FFFFF545H	TMQ0 option register 0	TQ0OPT0		√	√		00H
FFFFF546H	TMQ0 capture/compare register 0	TQ0CCR0				√	0000H
FFFFF548H	TMQ0 capture/compare register 1	TQ0CCR1				√	0000H
FFFFF54AH	TMQ0 capture/compare register 2	TQ0CCR2				√	0000H
FFFFF54CH	TMQ0 capture/compare register 3	TQ0CCR3				√	0000H
FFFFF54EH	TMQ0 counter read buffer register	TQ0CNT	R			√	0000H
FFFFF590H	TMP0 control register 0	TP0CTL0	R/W	√	√		00H
FFFFF591H	TMP0 control register 1	TP0CTL1		√	√		00H
FFFFF592H	TMP0 I/O control register 0	TP0IOC0		√	√		00H
FFFFF593H	TMP0 I/O control register 1	TP0IOC1		√	√		00H
FFFFF594H	TMP0 I/O control register 2	TP0IOC2		√	√		00H
FFFFF595H	TMP0 option register 0	TP0OPT0		√	√		00H
FFFFF596H	TMP0 capture/compare register 0	TP0CCR0				√	0000H
FFFFF598H	TMP0 capture/compare register 1	TP0CCR1				√	0000H
FFFFF59AH	TMP0 counter read buffer register	TP0CNT	R			√	0000H
FFFFF5A0H	TMP1 control register 0	TP1CTL0	R/W	√	√		00H
FFFFF5A1H	TMP1 control register 1	TP1CTL1		√	√		00H
FFFFF5A2H	TMP1 I/O control register 0	TP1IOC0		√	√		00H

**Note** V850E/SK3-H only

Address	Function Register Name	Symbol	R/W	Manipulatable Bits			Default Value	
				1	8	16		
FFFFF5A3H	TMP1 I/O control register 1	TP1IOC1	R/W	√	√		00H	
FFFFF5A4H	TMP1 I/O control register 2	TP1IOC2		√	√		00H	
FFFFF5A5H	TMP1 option register 0	TP1OPT0		√	√		00H	
FFFFF5A6H	TMP1 capture/compare register 0	TP1CCR0				√	0000H	
FFFFF5A8H	TMP1 capture/compare register 1	TP1CCR1				√	0000H	
FFFFF5AAH	TMP1 counter read buffer register	TP1CNT	R			√	0000H	
FFFFF5B0H	TMP2 control register 0	TP2CTL0	R/W	√	√		00H	
FFFFF5B1H	TMP2 control register 1	TP2CTL1		√	√		00H	
FFFFF5B2H	TMP2 I/O control register 0	TP2IOC0		√	√		00H	
FFFFF5B3H	TMP2 I/O control register 1	TP2IOC1		√	√		00H	
FFFFF5B4H	TMP2 I/O control register 2	TP2IOC2		√	√		00H	
FFFFF5B5H	TMP2 option register 0	TP2OPT0		√	√		00H	
FFFFF5B6H	TMP2 capture/compare register 0	TP2CCR0				√	0000H	
FFFFF5B8H	TMP2 capture/compare register 1	TP2CCR1				√	0000H	
FFFFF5BAH	TMP2 counter read buffer register	TP2CNT		R			√	0000H
FFFFF5C0H	TMP3 control register 0	TP3CTL0		R/W	√	√		00H
FFFFF5C1H	TMP3 control register 1	TP3CTL1	√		√		00H	
FFFFF5C2H	TMP3 I/O control register 0	TP3IOC0	√		√		00H	
FFFFF5C3H	TMP3 I/O control register 1	TP3IOC1	√		√		00H	
FFFFF5C4H	TMP3 I/O control register 2	TP3IOC2	√		√		00H	
FFFFF5C5H	TMP3 option register 0	TP3OPT0	R/W	√	√		00H	
FFFFF5C6H	TMP3 capture/compare register 0	TP3CCR0				√	0000H	
FFFFF5C8H	TMP3 capture/compare register 1	TP3CCR1				√	0000H	
FFFFF5CAH	TMP3 counter read buffer register	TP3CNT	R			√	0000H	
FFFFF5D0H	TMP4 control register 0	TP4CTL0	R/W	√	√		00H	
FFFFF5D1H	TMP4 control register 1	TP4CTL1		√	√		00H	
FFFFF5D2H	TMP4 I/O control register 0	TP4IOC0		√	√		00H	
FFFFF5D3H	TMP4 I/O control register 1	TP4IOC1		√	√		00H	
FFFFF5D4H	TMP4 I/O control register 2	TP4IOC2		√	√		00H	
FFFFF5D5H	TMP4 option register 0	TP4OPT0		√	√		00H	
FFFFF5D6H	TMP4 capture/compare register 0	TP4CCR0				√	0000H	
FFFFF5D8H	TMP4 capture/compare register 1	TP4CCR1				√	0000H	
FFFFF5DAH	TMP4 counter read buffer register	TP4CNT		R			√	0000H
FFFFF5E0H	TMP5 control register 0	TP5CTL0		R/W	√	√		00H
FFFFF5E1H	TMP5 control register 1	TP5CTL1	√		√		00H	
FFFFF5E2H	TMP5 I/O control register 0	TP5IOC0	√		√		00H	
FFFFF5E3H	TMP5 I/O control register 1	TP5IOC1	√		√		00H	
FFFFF5E4H	TMP5 I/O control register 2	TP5IOC2	√		√		00H	
FFFFF5E5H	TMP5 option register 0	TP5OPT0	√		√		00H	
FFFFF5E6H	TMP5 capture/compare register 0	TP5CCR0				√	0000H	
FFFFF5E8H	TMP5 capture/compare register 1	TP5CCR1	R/W			√	0000H	
FFFFF5EAH	TMP5 counter read buffer register	TP5CNT	R			√	0000H	

Address	Function Register Name	Symbol	R/W	Manipulatable Bits			Default Value	
				1	8	16		
FFFFF5F0H	TMP6 control register 0	TP6CTL0	R/W	√	√		00H	
FFFFF5F1H	TMP6 control register 1	TP6CTL1		√	√		00H	
FFFFF5F2H	TMP6 I/O control register 0	TP6IOC0		√	√		00H	
FFFFF5F3H	TMP6 I/O control register 1	TP6IOC1		√	√		00H	
FFFFF5F4H	TMP6 I/O control register 2	TP6IOC2		√	√		00H	
FFFFF5F5H	TMP6 option register 0	TP6OPT0		√	√		00H	
FFFFF5F6H	TMP6 capture/compare register 0	TP6CCR0				√	0000H	
FFFFF5F8H	TMP6 capture/compare register 1	TP6CCR1				√	0000H	
FFFFF5FAH	TMP6 counter read buffer register	TP6CNT	R			√	0000H	
FFFFF640H	TMP7 control register 0	TP7CTL0	R/W	√	√		00H	
FFFFF641H	TMP7 control register 1	TP7CTL1		√	√		00H	
FFFFF642H	TMP7 control register 2	TP7CTL2		√	√		00H	
FFFFF643H	TMP7 I/O control register 0	TP7IOC0		√	√		00H	
FFFFF644H	TMP7 I/O control register 1	TP7IOC1		√	√		00H	
FFFFF645H	TMP7 I/O control register 2	TP7IOC2		√	√		00H	
FFFFF646H	TMP7 I/O control register 3	TP7IOC3		√	√		00H	
FFFFF647H	TMP7 option register 0	TP7OPT0		√	√		00H	
FFFFF648H	TMP7 option register 1	TP7OPT1		√	√		00H	
FFFFF64AH	TMP7 capture/compare register 0	TP7CCR0				√	0000H	
FFFFF64CH	TMP7 capture/compare register 1	TP7CCR1				√	0000H	
FFFFF64EH	TMP7 counter read buffer register	TP7CNT		R			√	0000H
FFFFF650H	TMP7 counter write register	TP7TCW		R/W			√	0000H
FFFFF660H	TMP8 control register 0	TP8CTL0		R/W	√	√		00H
FFFFF661H	TMP8 control register 1	TP8CTL1			√	√		00H
FFFFF662H	TMP8 control register 2	TP8CTL2			√	√		00H
FFFFF663H	TMP8 I/O control register 0	TP8IOC0	√		√		00H	
FFFFF664H	TMP8 I/O control register 1	TP8IOC1	√		√		00H	
FFFFF665H	TMP8 I/O control register 2	TP8IOC2	√		√		00H	
FFFFF666H	TMP8 I/O control register 3	TP8IOC3	√		√		00H	
FFFFF667H	TMP8 option register 0	TP8OPT0	√		√		00H	
FFFFF668H	TMP8 option register 1	TP8OPT1	√		√		00H	
FFFFF66AH	TMP8 capture/compare register 0	TP8CCR0				√	0000H	
FFFFF66CH	TMP8 capture/compare register 1	TP8CCR1				√	0000H	
FFFFF66EH	TMP8 counter read buffer register	TP8CNT	R				√	0000H
FFFFF670H	TMP8 counter write register	TP8TCW	R/W				√	0000H
FFFFF680H	Watch timer operation mode register	WTM			√	√		00H
FFFFF690H	TMM0 control register 0	TM0CTL0			√	√		00H
FFFFF694H	TMM0 compare register 0	TM0CMP0				√	0000H	
FFFFF6A0H	TMM1 control register 0	TM1CTL0		√	√		00H	
FFFFF6A4H	TMM1 compare register 0	TM1CMP0			√	0000H		
FFFFF6B0H	TMM2 control register 0	TM2CTL0		√	√		00H	
FFFFF6B4H	TMM2 compare register 0	TM2CMP0			√	0000H		

Address	Function Register Name	Symbol	R/W	Manipulatable Bits				Default Value
				1	8	16	32	
FFFFF6C0H	Oscillation stabilization time select register	OSTS	R/W		√			06H
FFFFF6C1H	PLL lockup time specification register	PLLS			√			03H
FFFFF6D0H	Watchdog timer mode register 2	WDTM2			√			67H
FFFFF6D1H	Watchdog timer enable register	WDTE			√			9AH
FFFFF6E0H	Real-time output buffer register 0L	RTBL0		√	√			00H
FFFFF6E2H	Real-time output buffer register 0H	RTBH0		√	√			00H
FFFFF6E4H	Real-time output port mode register 0	RTPM0		√	√			00H
FFFFF6E5H	Real-time output port control register 0	RTPC0		√	√			00H
FFFFF6F0H	Real-time output buffer register 1L	RTBL1		√	√			00H
FFFFF6F2H	Real-time output buffer register 1H	RTBH1		√	√			00H
FFFFF6F4H	Real-time output port mode register 1	RTPM1		√	√			00H
FFFFF6F5H	Real-time output port control register 1	RTPC1		√	√			00H
FFFFF700H	Port 0 function control expansion register	PFCE0 <sup>Note</sup>		√	√			00H
FFFFF706H	Port 3 function control expansion register	PFCE3				√		0000H
FFFFF706H	Port 3 function control expansion register L	PFCE3L	√	√			00H	
FFFFF707H	Port 3 function control expansion register H	PFCE3H	√	√			00H	
FFFFF70AH	Port 5 function control expansion register	PFCE5	√				00H	
FFFFF70CH	Port 6 function control expansion register	PFCE6			√		0000H	
FFFFF70CH	Port 6 function control expansion register L	PFCE6L	√	√			00H	
FFFFF70DH	Port 6 function control expansion register H	PFCE6H	√	√			00H	
FFFFF710H	Port 8 function control expansion register	PFCE8	√	√			00H	
FFFFF712H	Port 9 function control expansion register	PFCE9			√		0000H	
FFFFF712H	Port 9 function control expansion register L	PFCE9L	√	√			00H	
FFFFF713H	Port 9 function control expansion register H	PFCE9H	√	√			00H	
FFFFF802H	System status register	SYS	√	√			00H	
FFFFF80CH	Internal oscillation mode register	RCM	√	√			00H	
FFFFF810H	DMA trigger factor register 0	DTFR0	√	√			00H	
FFFFF812H	DMA trigger factor register 1	DTFR1	√	√			00H	
FFFFF814H	DMA trigger factor register 2	DTFR2	√	√			00H	
FFFFF816H	DMA trigger factor register 3	DTFR3	√	√			00H	
FFFFF820H	Power save mode register	PSMR	√	√			00H	
FFFFF822H	Clock control register	CKC	√	√			0AH	
FFFFF824H	Lock register	LOCKR	R	√	√		00H	
FFFFF828H	Processor clock control register	PCC	R/W	√	√		03H	
FFFFF82CH	PLL control register	PLLCTL		√	√		01H	
FFFFF82EH	CPU operation clock status register	CCLS	R	√	√		00H	
FFFFF840H	Correction address register 0	CORAD0	R/W			√	0000000H	
FFFFF840H	Correction address register 0L	CORAD0L				√	0000H	
FFFFF842H	Correction address register 0H	CORAD0H				√	0000H	
FFFFF844H	Correction address register 1	CORAD1				√	0000000H	
FFFFF844H	Correction address register 1L	CORAD1L				√	0000H	
FFFFF846H	Correction address register 1H	CORAD1H				√	0000H	

&lt;R&gt;

&lt;R&gt;

**Note** Not available in the  $\mu$ PD70F3931 (V850E/SJ3-H), 70F3932 (V850E/SJ3-H), and 70F3933 (V850E/SJ3-H)

Address	Function Register Name	Symbol	R/W	Manipulatable Bits				Default Value
				1	8	16	32	
FFFFF848H	Correction address register 2	CORAD2	R/W				√	0000000H
FFFFF848H	Correction address register 2L	CORAD2L				√		0000H
FFFFF84AH	Correction address register 2H	CORAD2H				√		0000H
FFFFF84CH	Correction address register 3	CORAD3	R/W				√	0000000H
FFFFF84CH	Correction address register 3L	CORAD3L				√		0000H
FFFFF84EH	Correction address register 3H	CORAD3H				√		0000H
FFFFF850H	Correction address register 4	CORAD4	R/W				√	0000000H
FFFFF850H	Correction address register 4L	CORAD4L				√		0000H
FFFFF852H	Correction address register 4H	CORAD4H				√		0000H
FFFFF854H	Correction address register 5	CORAD5	R/W				√	0000000H
FFFFF854H	Correction address register 5L	CORAD5L				√		0000H
FFFFF856H	Correction address register 5H	CORAD5H				√		0000H
FFFFF858H	Correction address register 6	CORAD6	R/W				√	0000000H
FFFFF858H	Correction address register 6L	CORAD6L				√		0000H
FFFFF85AH	Correction address register 6H	CORAD6H				√		0000H
FFFFF85CH	Correction address register 7	CORAD7	R/W				√	0000000H
FFFFF85CH	Correction address register 7L	CORAD7L				√		0000H
FFFFF85EH	Correction address register 7H	CORAD7H				√		0000H
FFFFF870H	Clock monitor mode register	CLM	R/W	√	√			00H
FFFFF880H	Correction control register	CORCN	R/W	√	√			00H
FFFFF888H	Reset source flag register	RESF	R/W	√	√			00H
FFFFF890H	Low-voltage detection register	LVIM	R/W	√	√			00H
FFFFF891H	Low-voltage detection level select register	LVIS	R/W		√			00H
FFFFF892H	Internal RAM data status register	RAMS	R/W	√	√			01H <sup>Note 1</sup>
FFFFF8B0H	Prescaler mode register 0	PRSM0	R/W	√	√			00H
FFFFF8B1H	Prescaler compare register 0	PRSCM0	R/W		√			00H
<R> FFFFF900H	CSIE0 control register 0	CE0CTL0 <sup>Note 2</sup>	R/W	√	√			00H
<R> FFFFF901H	CSIE0 control register 1	CE0CTL1 <sup>Note 2</sup>	R/W	√	√			07H
<R> FFFFF902H	CSIE0 receive data buffer register	CE0RX0 <sup>Note 2</sup>	R			√		0000H
<R> FFFFF902H	CSIE0 receive data buffer register L	CE0RX0L <sup>Note 2</sup>	R		√			00H
<R> FFFFF903H	CSIE0 receive data buffer register H	CE0RX0H <sup>Note 2</sup>	R		√			00H
<R> FFFFF906H	CSIE0 transmit data buffer register	CE0TX0 <sup>Note 2</sup>	R/W			√		0000H
<R> FFFFF906H	CSIE0 transmit data buffer register L	CE0TX0L <sup>Note 2</sup>	R/W		√			00H
<R> FFFFF907H	CSIE0 transmit data buffer register H	CE0TX0H <sup>Note 2</sup>	R/W		√			00H
<R> FFFFF908H	CSIE0 status register	CE0STR <sup>Note 2</sup>	R/W	√	√			20H
<R> FFFFF909H	CSIE0 control register 2	CE0CTL2 <sup>Note 2</sup>	R/W	√	√			00H
<R> FFFFF90CH	CSIE0 control register 3	CE0CTL3 <sup>Note 2</sup>	R/W	√	√			00H
<R> FFFFF940H	CSIE1 control register 0	CE1CTL0 <sup>Note 2</sup>	R/W	√	√			00H
<R> FFFFF941H	CSIE1 control register 1	CE1CTL1 <sup>Note 2</sup>	R/W	√	√			07H

**Notes** 1. The default value indicates the value after the power is turned on.

The status before a reset is retained after the reset.

<R> 2. Not available in the  $\mu$ PD70F3931 (V850E/SJ3-H), 70F3932 (V850E/SJ3-H), and 70F3933 (V850E/SJ3-H)

	Address	Function Register Name	Symbol	R/W	Manipulatable Bits			Default Value
					1	8	16	
<R>	FFFFF942H	CSIE1 receive data buffer register	CE1RX0 <sup>Note 1</sup>	R			√	0000H
<R>	FFFFF942H	CSIE1 receive data buffer register L	CE1RX0L <sup>Note 1</sup>			√		00H
<R>	FFFFF943H	CSIE1 receive data buffer register H	CE1RX0H <sup>Note 1</sup>			√		00H
<R>	FFFFF946H	CSIE1 transmit data buffer register	CE1TX0 <sup>Note 1</sup>				√	0000H
<R>	FFFFF946H	CSIE1 transmit data buffer register L	CE1TX0L <sup>Note 1</sup>			√		00H
<R>	FFFFF947H	CSIE1 transmit data buffer register H	CE1TX0H <sup>Note 1</sup>			√		00H
<R>	FFFFF948H	CSIE1 status register	CE1STR <sup>Note 1</sup>		√	√		20H
<R>	FFFFF949H	CSIE1 control register 2	CE1CTL2 <sup>Note 1</sup>		√	√		00H
<R>	FFFFF94CH	CSIE1 control register 3	CE1CTL3 <sup>Note 1</sup>		√	√		00H
	FFFFF9FCH	On-chip debug mode register	OCDM		√	√		01H
	FFFFF9FEH	Peripheral emulation register 1	PEMU1 <sup>Note 2</sup>		√	√		00H
	FFFFFA00H	UARTA0 control register 0	UA0CTL0		√	√		10H
	FFFFFA01H	UARTA0 control register 1	UA0CTL1			√		00H
	FFFFFA02H	UARTA0 control register 2	UA0CTL2			√		FFH
	FFFFFA03H	UARTA0 option control register 0	UA0OPT0		√	√		14H
	FFFFFA04H	UARTA0 status register	UA0STR		√	√		00H
	FFFFFA06H	UARTA0 receive data register	UA0RX	R		√		FFH
	FFFFFA07H	UARTA0 transmit data register	UA0TX	R/W		√		FFH
	FFFFFA10H	UARTA1 control register 0	UA1CTL0		√	√		10H
	FFFFFA11H	UARTA1 control register 1	UA1CTL1			√		00H
	FFFFFA12H	UARTA1 control register 2	UA1CTL2			√		FFH
	FFFFFA13H	UARTA1 option control register 0	UA1OPT0		√	√		14H
	FFFFFA14H	UARTA1 status register	UA1STR		√	√		00H
	FFFFFA16H	UARTA1 receive data register	UA1RX	R		√		FFH
	FFFFFA17H	UARTA1 transmit data register	UA1TX	R/W		√		FFH
	FFFFFA20H	UARTA2 control register 0	UA2CTL0		√	√		10H
	FFFFFA21H	UARTA2 control register 1	UA2CTL1			√		00H
	FFFFFA22H	UARTA2 control register 2	UA2CTL2			√		FFH
	FFFFFA23H	UARTA2 option control register 0	UA2OPT0		√	√		14H
	FFFFFA24H	UARTA2 status register	UA2STR		√	√		00H
	FFFFFA26H	UARTA2 receive data register	UA2RX	R		√		FFH
	FFFFFA27H	UARTA2 transmit data register	UA2TX	R/W		√		FFH
	FFFFFA30H	UARTA3 control register 0	UA3CTL0		√	√		10H
	FFFFFA31H	UARTA3 control register 1	UA3CTL1			√		00H
	FFFFFA32H	UARTA3 control register 2	UA3CTL2			√		FFH
	FFFFFA33H	UARTA3 option control register 0	UA3OPT0	R/W	√	√		14H
	FFFFFA34H	UARTA3 status register	UA3STR		√	√		00H
	FFFFFA36H	UARTA3 receive data register	UA3RX	R		√		FFH
	FFFFFA37H	UARTA3 transmit data register	UA3TX	R/W		√		FFH
	FFFFFA40H	UARTA4 control register 0	UA4CTL0		√	√		10H

<R> **Notes** 1. Not available in the  $\mu$ PD70F3931 (V850E/SJ3-H), 70F3932 (V850E/SJ3-H), and 70F3933 (V850E/SJ3-H)  
2. Only during emulation

Address	Function Register Name	Symbol	R/W	Manipulatable Bits			Default Value
				1	8	16	
FFFFFFA41H	UARTA4 control register 1	UA4CTL1	R/W		√		00H
FFFFFFA42H	UARTA4 control register 2	UA4CTL2			√		FFH
FFFFFFA43H	UARTA4 option control register 0	UA4OPT0		√	√		14H
FFFFFFA44H	UARTA4 status register	UA4STR		√	√		00H
FFFFFFA46H	UARTA4 receive data register	UA4RX	R		√		FFH
FFFFFFA47H	UARTA4 transmit data register	UA4TX	R/W		√		FFH
FFFFFFA50H	UARTA5 control register 0	UA5CTL0		√	√		10H
FFFFFFA51H	UARTA5 control register 1	UA5CTL1			√		00H
FFFFFFA52H	UARTA5 control register 2	UA5CTL2			√		FFH
FFFFFFA53H	UARTA5 option control register 0	UA5OPT0		√	√		14H
FFFFFFA54H	UARTA5 status register	UA5STR		√	√		00H
FFFFFFA56H	UARTA5 receive data register	UA5RX	R		√		FFH
FFFFFFA57H	UARTA5 transmit data register	UA5TX	R/W		√		FFH
FFFFFFA80H	UARTB0 control register 0	UB0CTL0		√	√		10H
FFFFFFA82H	UARTB0 control register 2	UB0CTL2				√	FFFFH
FFFFFFA84H	UARTB0 status register	UB0STR		√	√		00H
FFFFFFA86H	UARTB0 receive data register AP	UB0RXAP	R			√	00FFH
FFFFFFA86H	UARTB0 receive data register	UB0RX			√		FFH
FFFFFFA88H	UARTB0 transmit data register	UB0TX	W		√		FFH
FFFFFFA8AH	UARTB0 FIFO control register 0	UB0FIC0	R/W	√	√		00H
FFFFFFA8BH	UARTB0 FIFO control register 1	UB0FIC1		√	√		00H
FFFFFFA8CH	UARTB0 FIFO control register 2	UB0FIC2				√	0000H
FFFFFFA8CH	UARTB0 FIFO control register 2L	UB0FIC2L			√		00H
FFFFFFA8DH	UARTB0 FIFO control register 2H	UB0FIC2H		√		00H	
FFFFFFA8EH	UARTB0 FIFO status register 0	UB0FIS0	R		√		00H
FFFFFFA8FH	UARTB0 FIFO status register 1	UB0FIS1			√		10H
FFFFFFAA0H	UARTB1 control register 0	UB1CTL0	R/W	√	√		10H
FFFFFFAA2H	UARTB1 control register 2	UB1CTL2				√	FFFFH
FFFFFFAA4H	UARTB1 status register	UB1STR		√	√		00H
FFFFFFAA6H	UARTB1 receive data register AP	UB1RXAP	R			√	00FFH
FFFFFFAA6H	UARTB1 receive data register	UB1RX			√		FFH
FFFFFFAA8H	UARTB1 transmit data register	UB1TX	W		√		FFH
FFFFFFAAAH	UARTB1 FIFO control register 0	UB1FIC0	R/W	√	√		00H
FFFFFFAABH	UARTB1 FIFO control register 1	UB1FIC1		√	√		00H
FFFFFFAACH	UARTB1 FIFO control register 2	UB1FIC2				√	0000H
FFFFFFAACH	UARTB1 FIFO control register 2L	UB1FIC2L			√		00H
FFFFFFAADH	UARTB1 FIFO control register 2H	UB1FIC2H		√		00H	
FFFFFFAAEH	UARTB1 FIFO status register 0	UB1FIS0	R		√		00H
FFFFFFAAFH	UARTB1 FIFO status register 1	UB1FIS1			√		10H
FFFFFFAD0H	Subcount register	RC1SUBC			√	0000H	
FFFFFFAD2H	Second count register	RC1SEC	R/W		√		00H
FFFFFFAD3H	Minute count register	RC1MIN			√		00H



Address	Function Register Name	Symbol	R/W	Manipulatable Bits			Default Value
				1	8	16	
FFFFFAD4H	Hour count register	RC1HOUR	R/W		√		12H
FFFFFAD5H	Week count register	RC1WEEK			√		00H
FFFFFAD6H	Day count register	RC1DAY			√		01H
FFFFFAD7H	Month count register	RC1MONTH			√		01H
FFFFFAD8H	Year count register	RC1YEAR			√		00H
FFFFFAD9H	Watch error correct register	RC1SUBU		√	√		00H
FFFFFADAH	Alarm minute setting register	RC1ALM			√		00H
FFFFFADBH	Alarm hour setting register	RC1ALH			√		12H
FFFFFADCH	Alarm week setting register	RC1ALW			√		00H
FFFFFADDH	Real-time counter control register 0	RC1CC0		√	√		00H
FFFFFADEH	Real-time counter control register 1	RC1CC1		√	√		00H
FFFFFADFH	Real-time counter control register 2	RC1CC2		√	√		00H
FFFFFAE0H	Real-time counter control register 3	RC1CC3		√	√		00H
FFFFFC00H	External interrupt falling edge specification register 0	INTF0		√	√		00H
FFFFFC06H	External interrupt falling edge specification register 3	INTF3		√	√		00H
FFFFFC08H	External interrupt falling edge specification register 4	INTF4		√	√		00H
FFFFFC0AH	External interrupt falling edge specification register 5	INTF5		√	√		00H
FFFFFC0CH	External interrupt falling edge specification register 6	INTF6		√	√		00H
FFFFFC10H	External interrupt falling edge specification register 8	INTF8		√	√		00H
FFFFFC12H	External interrupt falling edge specification register 9	INTF9				√	0000H
FFFFFC12H	External interrupt falling edge specification register 9L	INTF9L	√	√		00H	
FFFFFC13H	External interrupt falling edge specification register 9H	INTF9H	√	√		00H	
FFFFFC1EH	External interrupt falling edge specification register 15	INTF15 <sup>Note</sup>	√	√		00H	
FFFFFC20H	External interrupt rising edge specification register 0	INTR0	√	√		00H	
FFFFFC26H	External interrupt rising edge specification register 3	INTR3	√	√		00H	
FFFFFC28H	External interrupt rising edge specification register 4	INTR4	√	√		00H	
FFFFFC2AH	External interrupt rising edge specification register 5	INTR5	√	√		00H	
FFFFFC2CH	External interrupt rising edge specification register 6	INTR6	√	√		00H	
FFFFFC30H	External interrupt rising edge specification register 8	INTR8	√	√		00H	
FFFFFC32H	External interrupt rising edge specification register 9	INTR9			√	0000H	
FFFFFC32H	External interrupt rising edge specification register 9L	INTR9L	√	√		00H	
FFFFFC33H	External interrupt rising edge specification register 9H	INTR9H	√	√		00H	
FFFFFC3EH	External interrupt rising edge specification register 15	INTR15 <sup>Note</sup>	√	√		00H	
FFFFFC60H	Port 0 function register	PF0	√	√		00H	
FFFFFC64H	Port 2 function register	PF2 <sup>Note</sup>	√	√		00H	
FFFFFC66H	Port 3 function register	PF3			√	0000H	
FFFFFC66H	Port 3 function register L	PF3L	√	√		00H	
FFFFFC67H	Port 3 function register H	PF3H	√	√		00H	
FFFFFC68H	Port 4 function register	PF4	√	√		00H	
FFFFFC6AH	Port 5 function register	PF5	√	√		00H	

**Note** V850E/SK3-H only

Address	Function Register Name	Symbol	R/W	Manipulatable Bits			Default Value
				1	8	16	
FFFFFC6CH	Port 6 function register	PF6	R/W			√	0000H
FFFFFC6CH	Port 6 function register L	PF6L		√	√		00H
FFFFFC6DH	Port 6 function register H	PF6H		√	√		00H
FFFFFC70H	Port 8 function register	PF8		√	√		00H
FFFFFC72H	Port 9 function register	PF9				√	0000H
FFFFFC72H	Port 9 function register L	PF9L		√	√		00H
FFFFFC73H	Port 9 function register H	PF9H		√	√		00H
FFFFFC7EH	Port 15 function register	PF15 <sup>Note</sup>		√	√		00H
FFFFFC8H	Product selection register L	PRDSELL	R			√	Depends on product
FFFFCCAHA	Product selection register H	PRDSELH				√	Depends on product
FFFFFD00H	CSIB0 control register 0	CB0CTL0	R/W	√	√		01H
FFFFFD01H	CSIB0 control register 1	CB0CTL1		√	√		00H
FFFFFD02H	CSIB0 control register 2	CB0CTL2			√		00H
FFFFFD03H	CSIB0 status register	CB0STR		√	√		00H
FFFFFD04H	CSIB0 receive data register	CB0RX	R			√	0000H
FFFFFD04H	CSIB0 receive data register L	CB0RXL			√		00H
FFFFFD06H	CSIB0 transmit data register	CB0TX	R/W			√	0000H
FFFFFD06H	CSIB0 transmit data register L	CB0TXL			√		00H
FFFFFD10H	CSIB1 control register 0	CB1CTL0		√	√		01H
FFFFFD11H	CSIB1 control register 1	CB1CTL1		√	√		00H
FFFFFD12H	CSIB1 control register 2	CB1CTL2			√		00H
FFFFFD13H	CSIB1 status register	CB1STR		√	√		00H
FFFFFD14H	CSIB1 receive data register	CB1RX	R			√	0000H
FFFFFD14H	CSIB1 receive data register L	CB1RXL			√		00H
FFFFFD16H	CSIB1 transmit data register	CB1TX	R/W			√	0000H
FFFFFD16H	CSIB1 transmit data register L	CB1TXL			√		00H
FFFFFD20H	CSIB2 control register 0	CB2CTL0		√	√		01H
FFFFFD21H	CSIB2 control register 1	CB2CTL1		√	√		00H
FFFFFD22H	CSIB2 control register 2	CB2CTL2			√		00H
FFFFFD23H	CSIB2 status register	CB2STR		√	√		00H
FFFFFD24H	CSIB2 receive data register	CB2RX	R			√	0000H
FFFFFD24H	CSIB2 receive data register L	CB2RXL			√		00H
FFFFFD26H	CSIB2 transmit data register	CB2TX	R/W			√	0000H
FFFFFD26H	CSIB2 transmit data register L	CB2TXL			√		00H
FFFFFD30H	CSIB3 control register 0	CB3CTL0		√	√		01H
FFFFFD31H	CSIB3 control register 1	CB3CTL1		√	√		00H
FFFFFD32H	CSIB3 control register 2	CB3CTL2			√		00H
FFFFFD33H	CSIB3 status register	CB3STR		√	√		00H
FFFFFD34H	CSIB3 receive data register	CB3RX	R			√	0000H
FFFFFD34H	CSIB3 receive data register L	CB3RXL			√		00H

**Note** V850E/SK3-H only

Address	Function Register Name	Symbol	R/W	Manipulatable Bits			Default Value
				1	8	16	
FFFFFD36H	CSIB3 transmit data register	CB3TX	R/W			√	0000H
FFFFFD36H	CSIB3 transmit data register L	CB3TXL			√		00H
FFFFFD40H	CSIB4 control register 0	CB4CTL0		√	√		01H
FFFFFD41H	CSIB4 control register 1	CB4CTL1		√	√		00H
FFFFFD42H	CSIB4 control register 2	CB4CTL2			√		00H
FFFFFD43H	CSIB4 status register	CB4STR		√	√		00H
FFFFFD44H	CSIB4 receive data register	CB4RX	R			√	0000H
FFFFFD44H	CSIB4 receive data register L	CB4RXL			√		00H
FFFFFD46H	CSIB4 transmit data register	CB4TX	R/W			√	0000H
FFFFFD46H	CSIB4 transmit data register L	CB4TXL			√		00H
FFFFFD50H	CSIB5 control register 0	CB5CTL0		√	√		01H
FFFFFD51H	CSIB5 control register 1	CB5CTL1		√	√		00H
FFFFFD52H	CSIB5 control register 2	CB5CTL2			√		00H
FFFFFD53H	CSIB5 status register	CB5STR		√	√		00H
FFFFFD54H	CSIB5 receive data register	CB5RX	R			√	0000H
FFFFFD54H	CSIB5 receive data register L	CB5RXL			√		00H
FFFFFD56H	CSIB5 transmit data register	CB5TX	R/W			√	0000H
FFFFFD56H	CSIB5 transmit data register L	CB5TXL			√		00H
FFFFFD80H	IIC shift register 0	IIC0			√		00H
FFFFFD82H	IIC control register 0	IICC0		√	√		00H
FFFFFD83H	Slave address register 0	SVA0			√		00H
FFFFFD84H	IIC clock select register 0	IICCL0		√	√		00H
FFFFFD85H	IIC function expansion register 0	IICX0	√	√		00H	
FFFFFD86H	IIC status register 0	IICS0	R	√	√		00H
FFFFFD8AH	IIC flag register 0	IICF0	R/W	√	√		00H
FFFFFD90H	IIC shift register 1	IIC1			√		00H
FFFFFD92H	IIC control register 1	IICC1		√	√		00H
FFFFFD93H	Slave address register 1	SVA1			√		00H
FFFFFD94H	IIC clock select register 1	IICCL1		√	√		00H
FFFFFD95H	IIC function expansion register 1	IICX1		√	√		00H
FFFFFD96H	IIC status register 1	IICS1	R	√	√		00H
FFFFFD9AH	IIC flag register 1	IICF1	R/W	√	√		00H
FFFFFDA0H	IIC shift register 2	IIC2			√		00H
FFFFFDA2H	IIC control register 2	IICC2		√	√		00H
FFFFFDA3H	Slave address register 2	SVA2			√		00H
FFFFFDA4H	IIC clock select register 2	IICCL2		√	√		00H
FFFFFDA5H	IIC function expansion register 2	IICX2		√	√		00H
FFFFFDA6H	IIC status register 2	IICS2	R	√	√		00H
FFFFDAAH	IIC flag register 2	IICF2	R/W	√	√		00H
FFFFFDB0H	IIC shift register 3	IIC3			√		00H
FFFFFDB2H	IIC control register 3	IICC3		√	√		00H
FFFFFDB3H	Slave address register 3	SVA3			√		00H

Address	Function Register Name	Symbol	R/W	Manipulatable Bits			Default Value
				1	8	16	
FFFFFDB4H	IIC clock select register 3	IICCL3	R/W	√	√		00H
FFFFFDB5H	IIC function expansion register 3	IICX3		√	√		00H
FFFFFDB6H	IIC status register 3	IICS3	R	√	√		00H
FFFFFDBAH	IIC flag register 3	IICF3	R/W	√	√		00H
<R> FFFFFDC0H	IIC shift register 4	IIC4 <sup>Note</sup>			√		00H
<R> FFFFFDC2H	IIC control register 4	IIC4 <sup>Note</sup>		√	√		00H
<R> FFFFFDC3H	Slave address register 4	SVA4 <sup>Note</sup>			√		00H
<R> FFFFFDC4H	IIC clock select register 4	IICCL4 <sup>Note</sup>		√	√		00H
<R> FFFFFDC5H	IIC function expansion register 4	IICX4 <sup>Note</sup>		√	√		00H
<R> FFFFFDC6H	IIC status register 4	IICS4 <sup>Note</sup>	R	√	√		00H
<R> FFFFFDCAH	IIC flag register 4	IICF4 <sup>Note</sup>	R/W	√	√		00H
<R> FFFFFDD0H	IIC shift register 5	IIC5 <sup>Note</sup>			√		00H
<R> FFFFFDD2H	IIC control register 5	IIC5 <sup>Note</sup>		√	√		00H
<R> FFFFFDD3H	Slave address register 5	SVA5 <sup>Note</sup>			√		00H
<R> FFFFFDD4H	IIC clock select register 5	IICCL5 <sup>Note</sup>		√	√		00H
<R> FFFFFDD5H	IIC function expansion register 5	IICX5 <sup>Note</sup>		√	√		00H
<R> FFFFFDD6H	IIC status register 5	IICS5 <sup>Note</sup>	R	√	√		00H
<R> FFFFFDDAH	IIC flag register 5	IICF5 <sup>Note</sup>	R/W	√	√		00H
FFFFFBEH	External bus interface mode control register	EXIMC		√	√		00H

<R> **Note** Not available in the  $\mu$ PD70F3931 (V850E/SJ3-H), 70F3932 (V850E/SJ3-H), and 70F3933 (V850E/SJ3-H)

**3.4.7 Programmable peripheral I/O registers**

The BPC register is used for programmable peripheral I/O register area selection.

**(1) Peripheral I/O area select control register (BPC)**

The BPC register can be read or written in 16-bit units.

Reset sets this register to 0000H.

	15	14	13	12	11	10	9	8	7	6	5	4	3	2	1	0	Address	Default value
BPC	PA15	0	PA13	PA12	PA11	PA10	PA09	PA08	PA07	PA06	PA05	PA04	PA03	PA02	PA01	PA00	FFFFFF064H	0000H

Bit position	Bit name	Function						
15	PA15	Enables/disables usage of programmable peripheral I/O area. <table border="1" style="margin-left: 20px; border-collapse: collapse; width: 80%;"> <thead> <tr> <th style="width: 10%;">PA15</th> <th style="width: 90%;">Usage of programmable peripheral I/O area</th> </tr> </thead> <tbody> <tr> <td style="text-align: center;">0</td> <td>Usage of programmable peripheral I/O area disabled</td> </tr> <tr> <td style="text-align: center;">1</td> <td>Usage of programmable peripheral I/O area enabled</td> </tr> </tbody> </table>	PA15	Usage of programmable peripheral I/O area	0	Usage of programmable peripheral I/O area disabled	1	Usage of programmable peripheral I/O area enabled
PA15	Usage of programmable peripheral I/O area							
0	Usage of programmable peripheral I/O area disabled							
1	Usage of programmable peripheral I/O area enabled							
13 to 0	PA13 to PA00	Specify an address in programmable peripheral I/O area (corresponding to A27 to A14, respectively).						

**Caution** When setting the PA15 bit to 1, be sure to set the BPC register to 8FFBH.  
 When clearing the PA15 bit to 0, be sure to set the BPC register to 0000H.

For a list of the programmable peripheral I/O register areas, see **Table 21-16 Register Access Types**.

### 3.4.8 Special registers

Special registers are registers that are protected from being written with illegal data due to a program hang-up. The V850E/SJ3-H and V850E/SK3-H have the following ten special registers.

- Power save control register (PSC)
- Clock control register (CKC)
- Processor clock control register (PCC)
- SSCG frequency control register 0 (SFC0)
- SSCG frequency control register 1 (SFC1)
- Clock monitor mode register (CLM)
- Reset source flag register (RESF)
- Low-voltage detection register (LVIM)
- Internal RAM data status register (RAMS)
- On-chip debug mode register (OCDM)

In addition, the PRCDM register is provided to protect against a write access to the special registers so that the application system does not inadvertently stop due to a program hang-up. A write access to the special registers is made in a specific sequence, and an illegal store operation is reported to the SYS register.

**(1) Setting data to special registers**

Set data to the special registers in the following sequence.

- <1> Disable DMA operation.
- <2> Prepare data to be set to the special register in a general-purpose register.
- <3> Write the data prepared in <2> to the PRCMD register.
- <4> Write the setting data to the special register (by using the following instructions).
  - Store instruction (ST/SST instruction)
  - Bit manipulation instruction (SET1/CLR1/NOT1 instruction)
- (<5> to <9> Insert NOP instructions (5 instructions).)<sup>Note</sup>
- <10> Enable DMA operation if necessary.

[Example] With PSC register (setting standby mode)

```

    ST.B r11, PSMR[r0] ; Set PSMR register (setting IDLE1, IDLE2, and STOP modes).
<1>CLR1 0, DCHCn[r0] ; Disable DMA operation. n = 0 to 3
<2>MOV0x02, r10
<3>ST.B r10, PRCMD[r0] ; Write PRCMD register.
<4>ST.B r10, PSC[r0] ; Set PSC register.
<5>NOPNote ; Dummy instruction
<6>NOPNote ; Dummy instruction
<7>NOPNote ; Dummy instruction
<8>NOPNote ; Dummy instruction
<9>NOPNote ; Dummy instruction
<10>SET1 0, DCHCn[r0] ; Enable DMA operation. n = 0 to 3
(next instruction)

```

There is no special sequence to read a special register.

**Note** Five NOP instructions or more must be inserted immediately after setting the IDLE1 mode, IDLE2 mode, or STOP mode (by setting the PSC.STP bit to 1).

- Cautions 1.** When a store instruction is executed to store data in the command register, interrupts are not acknowledged. This is because it is assumed that steps <3> and <4> above are performed by successive store instructions. If another instruction is placed between <3> and <4>, and if an interrupt is acknowledged by that instruction, the above sequence may not be established, causing malfunction.
- 2.** Although dummy data is written to the PRCMD register, use the same general-purpose register used to set the special register (<4> in Example) to write data to the PRCMD register (<3> in Example). The same applies when a general-purpose register is used for addressing.

**(2) Command register (PRCMD)**

The PRCMD register is an 8-bit register that protects the registers that may seriously affect the application system from being written, so that the system does not inadvertently stop due to a program hang-up. The first write access to a special register is valid after data has been written in advance to the PRCMD register. In this way, the value of the special register can be rewritten only in a specific sequence, so as to protect the register from an illegal write access.

The PRCMD register is write-only, in 8-bit units (undefined data is read when this register is read).

Reset makes this register undefined.

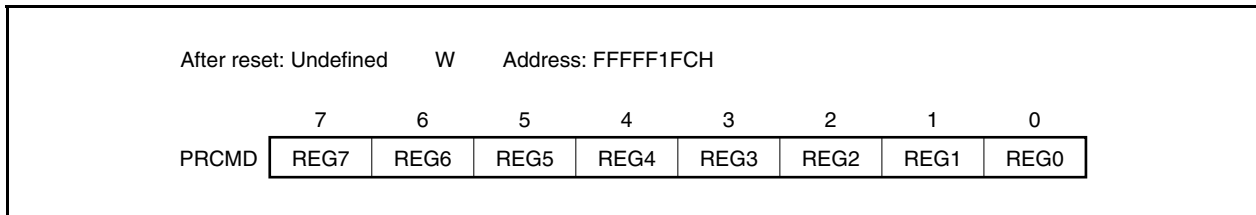



**(3) System status register (SYS)**

Status flags that indicate the operation status of the overall system are allocated to this register.

This register can be read or written in 8-bit or 1-bit units.

Reset sets this register to 00H.

After reset: 00H	R/W	Address: FFFFF802H							
		7	6	5	4	3	2	1	<0>
SYS		0	0	0	0	0	0	0	PRERR
	PRERR	Detects protection error							
	0	Protection error did not occur							
	1	Protection error occurred							

The PRERR flag operates under the following conditions.

**(a) Set condition (PRERR flag = 1)**

- (i) When data is written to a special register without writing anything to the PRCMD register (when <4> is executed without executing <3> in **3.4.8 (1) Setting data to special registers**)
- (ii) When data is written to an on-chip peripheral I/O register other than a special register (including execution of a bit manipulation instruction) after writing data to the PRCMD register (if <4> in **3.4.8 (1) Setting data to special registers** is not the setting of a special register)

**Remark** Even if an on-chip peripheral I/O register is read (except by a bit manipulation instruction) between an operation to write the PRCMD register and an operation to write a special register, the PRERR flag is not set, and the set data can be written to the special register.

**(b) Clear condition (PRERR flag = 0)**

- (i) When 0 is written to the PRERR flag
- (ii) When the system is reset

**Cautions 1.** If 0 is written to the PRERR bit of the SYS register, which is not a special register, immediately after a write access to the PRCMD register, the PRERR bit is cleared to 0 (the write access takes precedence).

**2.** If data is written to the PRCMD register, which is not a special register, immediately after a write access to the PRCMD register, the PRERR bit is set to 1.

### 3.4.9 Cautions

#### (1) Registers to be set first

Be sure to set the following registers first when using the V850E/SJ3-H and V850E/SK3-H.

- System wait control register (VSWC)
- On-chip debug mode register (OCDM)
- Watchdog timer mode register 2 (WDTM2)
- Registers related to expanded internal RAM
  - Bus size configuration register (BSC)
  - Data wait control register 1 (DWC1)
  - Address wait control register (AWC)
  - Bus cycle control register (BCC)
- Program ID register (ASID)
- Initialization setting registers when using clock modes 2, 3, and 4
  - Clock control register (CKC)
  - SSCG frequency control register 0 (SFC0)
  - SSCG frequency control register 1 (SFC1)

After setting the above registers, set the other registers as necessary.

When using the external bus, set each pin to the alternate-function bus control pin mode by using the port-related registers after setting the above registers.

#### (a) System wait control register (VSWC)

The VSWC register controls wait of bus access to the on-chip peripheral I/O registers.

Three clocks are required to access an on-chip peripheral I/O register (without a wait cycle). The V850E/SJ3-H and V850E/SK3-H require wait cycles according to the operating frequency. Set the following value to the VSWC register in accordance with the frequency used.

The VSWC register can be read or written in 8-bit units (address: FFFFF06EH, default value: 77H).

Operating Frequency ( $f_{CLK}$ )	Set Value of VSWC	Number of Waits
$32 \text{ kHz} \leq f_{CLK} < 16.6 \text{ MHz}$	00H	0 (no waits)
$16.6 \text{ MHz} \leq f_{CLK} < 25 \text{ MHz}$	01H	1
$25 \text{ MHz} \leq f_{CLK} < 33.3 \text{ MHz}$	11H	2
$33.3 \text{ MHz} \leq f_{CLK} \leq 48 \text{ MHz}$	12H	3

#### (b) On-chip debug mode register (OCDM)

For details, see **CHAPTER 34 ON-CHIP DEBUG FUNCTION**.

#### (c) Watchdog timer mode register 2 (WDTM2)

The WDTM2 register sets the overflow time and the operation clock of the watchdog timer 2.

The watchdog timer 2 automatically starts in the reset mode after reset is released. Write the WDTM2 register to activate this operation.

For details, refer to **CHAPTER 11 FUNCTIONS OF WATCHDOG TIMER 2**.

**(d) Registers related to expanded internal RAM**

The expanded internal RAM is accessed via the external bus interface. Before accessing the expanded internal RAM, be sure to set the registers related to the external bus interface (initial settings for the expanded internal RAM).

For details, refer to **3.4.4 (6) Expanded internal RAM**.

**(e) Program ID register (ASID)**

For details, refer to **3.2.2 (8) Program ID register (ASID)**.

**(f) Initialization setting register when using clock modes 2, 3, and 4**

For details, refer to **6.4.4 (1) Initialization setting for using clock modes 2, 3, and 4**.

**(2) Accessing specific on-chip peripheral I/O registers**

This product has two types of internal system buses.

One is a CPU bus and the other is a peripheral bus that interfaces with low-speed peripheral hardware.

The clock of the CPU bus and the clock of the peripheral bus are asynchronous. If an access to the CPU and an access to the peripheral hardware conflict, therefore, unexpected illegal data may be transferred. If there is a possibility of a conflict, the number of cycles for accessing the CPU changes when the peripheral hardware is accessed, so that correct data is transferred. As a result, the CPU does not start processing of the next instruction but enters the wait state. If this wait state occurs, the number of clocks required to execute an instruction increases by the number of wait clocks shown below.

This must be taken into consideration if real-time processing is required.

When specific on-chip peripheral I/O registers are accessed, more wait states may be required in addition to the wait states set by the VSWC register.

The access conditions and how to calculate the number of wait states to be inserted (number of CPU clocks) at this time are shown below.

(1/2)

Peripheral Function	Register Name	Access	k	
16-bit timer/event counter P (TMP) (n = 0 to 8)	TPnCNT	Read	1 or 2	
	TPnCCR0, TPnCCR1	Write	<ul style="list-style-type: none"> <li>• 1st access: No wait</li> <li>• Continuous write: 0 to 3</li> </ul>	
		Read	1 or 2	
16-bit timer/event counter Q (TMQ)	TQ0CNT	Read	1 or 2	
	TQ0CCR0 to TQ0CCR3	Write	<ul style="list-style-type: none"> <li>• 1st access: No wait</li> <li>• Continuous write: 0 to 3</li> </ul>	
		Read	1 or 2	
<R> 3-wire variable-length serial I/O E <R> (CSIE) <sup>Note</sup> <R> (n = 0, 1)	CEnCTL0 <sup>Note</sup>	Write	1 to 5	
	CEnTX0 <sup>Note</sup>	Write	0 to 4	
	CEnSTR <sup>Note</sup>	Read	1 to 5	
Asynchronous serial interface B (UARTB) (n = 0, 1)	UBnTX	Write	0 to 4	
	UBnRX UBnRXAP UBnFIS0 UBnFIS1	Read	1 to 5	
Watchdog timer 2 (WDT2)	WDTM2	Write (when WDT2 operating)	3	
Real-time output function (RTO)	RTBL0, RTBL1	Write (RTPCn.RTPOEn bit = 0)	1	
	RTBH0, RTBH1	Write (RTPCn.RTPOEn bit = 0)	1	
A/D converter	ADA0M0	Read	1 to 3	
	ADA0CR0 to ADA0CR15	Read	1 to 3	
	ADA0CR0H to ADA0CR15H	Read	1 to 3	
<R> I <sup>2</sup> C00 to I <sup>2</sup> C03, I <sup>2</sup> C04 <sup>Note</sup> , I <sup>2</sup> C05 <sup>Note</sup>	IICS0 to IICS3, IICS4 <sup>Note</sup> , IICS5 <sup>Note</sup>	Read	1	

<R> **Note** Not available in the  $\mu$ PD70F3931 (V850E/SJ3-H), 70F3932 (V850E/SJ3-H), and 70F3933 (V850E/SJ3-H)

Peripheral Function	Register Name	Access	k
CAN controller <sup>Note 1</sup> (n = 0, 1, m = 0 to 31, a = 1 to 4)	CnGMABT <sup>Note 1</sup> , CnGMABTD <sup>Note 1</sup> , CnMASKaL <sup>Note 1</sup> , CnMASKaH <sup>Note 1</sup> , CnLEC <sup>Note 1</sup> , CnINFO <sup>Note 1</sup> , CnERC <sup>Note 1</sup> , CnIE <sup>Note 1</sup> , CnINTS <sup>Note 1</sup> , CnBRP <sup>Note 1</sup> , CnBTR <sup>Note 1</sup> , CnTS <sup>Note 1</sup>	Read/write	$(f_{CPU}/f_{CANMOD} + 1)/(2 + j)$ (MIN.) <sup>Note 2</sup> $(2 \times f_{CPU}/f_{CANMOD} + 1)/(2 + j)$ (MAX.) <sup>Note 2</sup>
	CnGMCTRL <sup>Note 1</sup> , CnGMCS <sup>Note 1</sup> , CnCTRL <sup>Note 1</sup>	Read/write	$(f_{CPU}/f_{CAN} + 1)/(2 + j)$ (MIN.) <sup>Note 2</sup> $(2 \times f_{CPU}/f_{CAN} + 1)/(2 + j)$ (MAX.) <sup>Note 2</sup>
	CnRGPT <sup>Note 1</sup> , CnTGPT <sup>Note 1</sup>	Write	$(f_{CPU}/f_{CANMOD} + 1)/(2 + j)$ (MIN.) <sup>Note 2</sup> $(2 \times f_{CPU}/f_{CANMOD} + 1)/(2 + j)$ (MAX.) <sup>Note 2</sup>
		Read	$(3 \times f_{CPU}/f_{CANMOD} + 1)/(2 + j)$ (MIN.) <sup>Note 2</sup> $(4 \times f_{CPU}/f_{CANMOD} + 1)/(2 + j)$ (MAX.) <sup>Note 2</sup>
	CnLIPT <sup>Note 1</sup> , CnLOPT <sup>Note 1</sup>	Read	$(3 \times f_{CPU}/f_{CANMOD} + 1)/(2 + j)$ (MIN.) <sup>Note 2</sup> $(4 \times f_{CPU}/f_{CANMOD} + 1)/(2 + j)$ (MAX.) <sup>Note 2</sup>
	CnMCTRLm <sup>Note 1</sup>	Write	$(4 \times f_{CPU}/f_{CAN} + 1)/(2 + j)$ (MIN.) <sup>Note 2</sup> $(5 \times f_{CPU}/f_{CAN} + 1)/(2 + j)$ (MAX.) <sup>Note 2</sup>
		Read	$(3 \times f_{CPU}/f_{CAN} + 1)/(2 + j)$ (MIN.) <sup>Note 2</sup> $(4 \times f_{CPU}/f_{CAN} + 1)/(2 + j)$ (MAX.) <sup>Note 2</sup>
	CnMDATA01m <sup>Note 1</sup> , CnMDATA0m <sup>Note 1</sup> , CnMDATA1m <sup>Note 1</sup> , CnMDATA23m <sup>Note 1</sup> , CnMDATA2m <sup>Note 1</sup> , CnMDATA3m <sup>Note 1</sup> , CnMDATA45m <sup>Note 1</sup> , CnMDATA4m <sup>Note 1</sup> , CnMDATA5m <sup>Note 1</sup> , CnMDATA67m <sup>Note 1</sup> , CnMDATA6m <sup>Note 1</sup> , CnMDATA7m <sup>Note 1</sup> , CnMDLcM <sup>Note 1</sup> , CnMCONFm <sup>Note 1</sup> , CnMIDLm <sup>Note 1</sup> , CnMIDHm <sup>Note 1</sup>	Write (8 bits)	$(4 \times f_{CPU}/f_{CANMOD} + 1)/(2 + j)$ (MIN.) <sup>Note 2</sup> $(5 \times f_{CPU}/f_{CANMOD} + 1)/(2 + j)$ (MAX.) <sup>Note 2</sup>
		Write (16 bits)	$(2 \times f_{CPU}/f_{CANMOD} + 1)/(2 + j)$ (MIN.) <sup>Note 2</sup> $(3 \times f_{CPU}/f_{CANMOD} + 1)/(2 + j)$ (MAX.) <sup>Note 2</sup>
		Read (8/16 bits)	$(3 \times f_{CPU}/f_{CANMOD} + 1)/(2 + j)$ (MIN.) <sup>Note 2</sup> $(4 \times f_{CPU}/f_{CANMOD} + 1)/(2 + j)$ (MAX.) <sup>Note 2</sup>
CRC	CRCD	Write	1

Number of clocks necessary for access =  $3 + i + j + (2 + j) \times k$

- Notes 1.** CAN controller version only  
**2.** Digits below the decimal point are rounded up.

**Caution** Accessing the above registers is prohibited in the following statuses. If a wait cycle is generated, it can only be cleared by a reset.

- When the CPU operates with the subclock and the main clock oscillation is stopped
- When the CPU operates with the internal oscillation clock

**Remark** f<sub>CPU</sub>: CPU clock frequency  
f<sub>CANMOD</sub>: CAN module system clock  
f<sub>CAN</sub>: Clock supplied to CAN  
i: Values (0 or 1) of higher 4 bits of VSWC register  
j: Values (0 or 1) of lower 4 bits of VSWC register

**(3) Restriction on conflict between sld instruction and interrupt request****(a) Description**

If a conflict occurs between the decode operation of an instruction in <2> immediately before the sld instruction following an instruction in <1> and an interrupt request before the instruction in <1> is complete, the execution result of the instruction in <1> may not be stored in a register.

Instruction <1>

- ld instruction: ld.b, ld.h, ld.w, ld.bu, ld.hu
- sld instruction: sld.b, sld.h, sld.w, sld.bu, sld.hu
- Multiplication instruction: mul, mulh, mulhi, mulu

Instruction <2>

mov reg1, reg2	not reg1, reg2	satsubr reg1, reg2	satsub reg1, reg2
satadd reg1, reg2	satadd imm5, reg2	or reg1, reg2	xor reg1, reg2
and reg1, reg2	tst reg1, reg2	subr reg1, reg2	sub reg1, reg2
add reg1, reg2	add imm5, reg2	cmp reg1, reg2	cmp imm5, reg2
mulh reg1, reg2	shr imm5, reg2	sar imm5, reg2	shl imm5, reg2

<Example>

<i> ld.w [r11], r10  
 •  
 •  
 •

If the decode operation of the mov instruction <ii> immediately before the sld instruction <iii> and an interrupt request conflict before execution of the ld instruction <i> is complete, the execution result of instruction <i> may not be stored in a register.

<ii> mov r10, r28

<iii> sld.w 0x28, r10

**(b) Countermeasure**

<1> When compiler (CA850) is used

Use CA850 Ver. 2.61 or later because generation of the corresponding instruction sequence can be automatically suppressed.

<2> Countermeasure by assembler

When executing the sld instruction immediately after instruction <ii>, avoid the above operation using either of the following methods.

- Insert a nop instruction immediately before the sld instruction.
- Do not use the same register as the sld instruction destination register in the above instruction <ii> executed immediately before the sld instruction.

## CHAPTER 4 PORT FUNCTIONS

### 4.1 Features

#### 4.1.1 V850E/SJ3-H

- I/O ports: 128
  - 5 V tolerant/N-ch open-drain output switchable: 60 (ports 0, 3 to 6, 8, 9)
- Input/output specifiable in 1-bit units

#### 4.1.2 V850E/SK3-H

- I/O ports: 156
  - 5 V tolerant/N-ch open-drain output switchable: 78 (ports 0, 2 to 6, 8, 9, 15)
- Input/output specifiable in 1-bit units

## 4.2 Basic Port Configuration

### 4.2.1 V850E/SJ3-H

The V850E/SJ3-H features a total of 128 I/O ports consisting of ports 0, 1, 3 to 9, CD, CM, CS, CT, DH, and DL. The port configuration is shown below.

Figure 4-1. Port Configuration Diagram

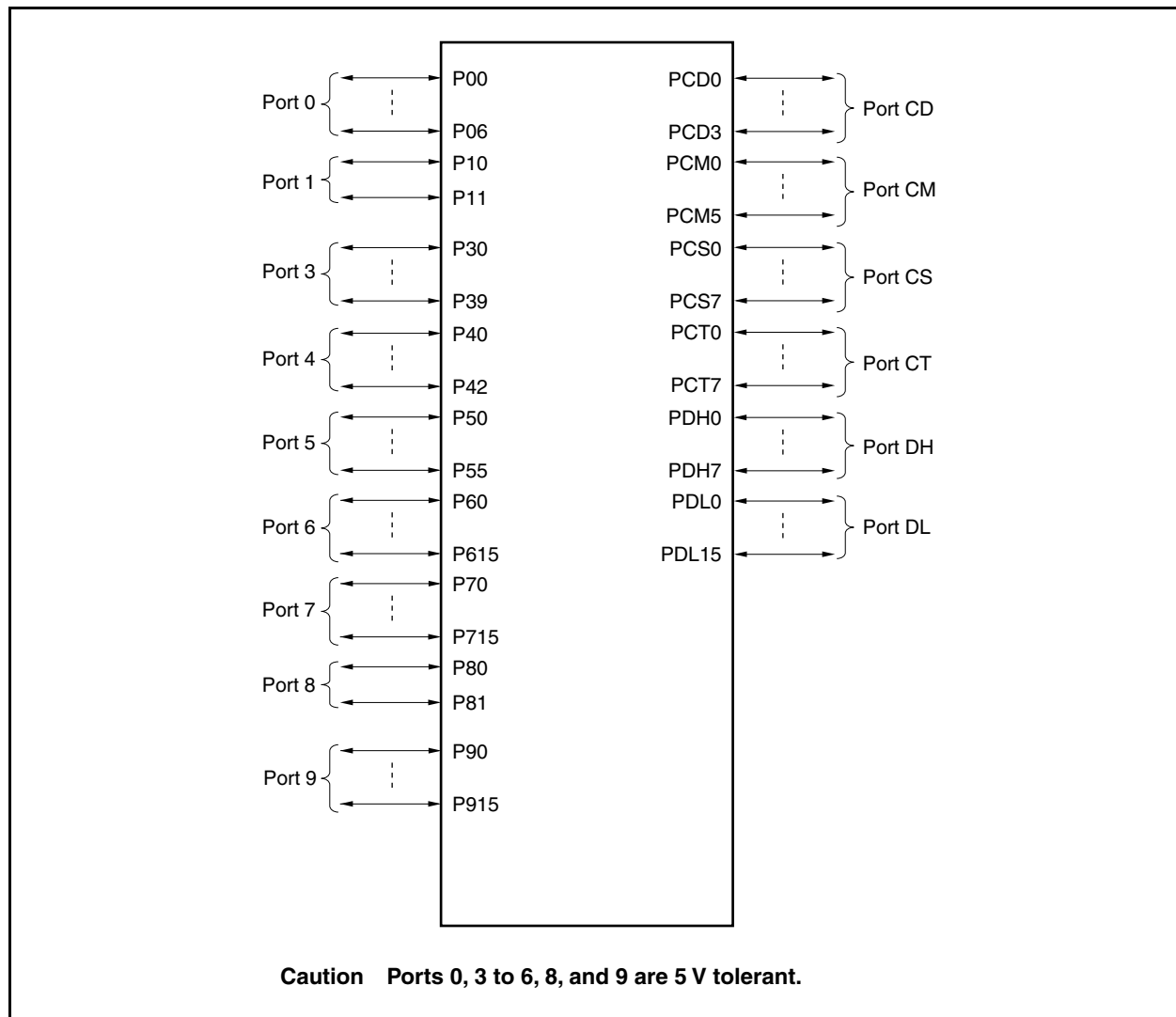

Table 4-1. I/O Buffer Power Supplies for Pins

Power Supply	Corresponding Pins
AVREF0	Port 7
AVREF1	Port 1
BVDD	Ports CD, CM, CS, CT, DH, DL
EVDD	$\overline{\text{RESET}}$ , ports 0, 3 to 6, 8, 9



4.2.2 V850E/SK3-H

The V850E/SK3-H features a total of 156 I/O ports consisting of ports 0 to 9, 13 to 15, CD, CM, CS, CT, DH, and DL.

The port configuration is shown below.

Figure 4-2. Port Configuration Diagram

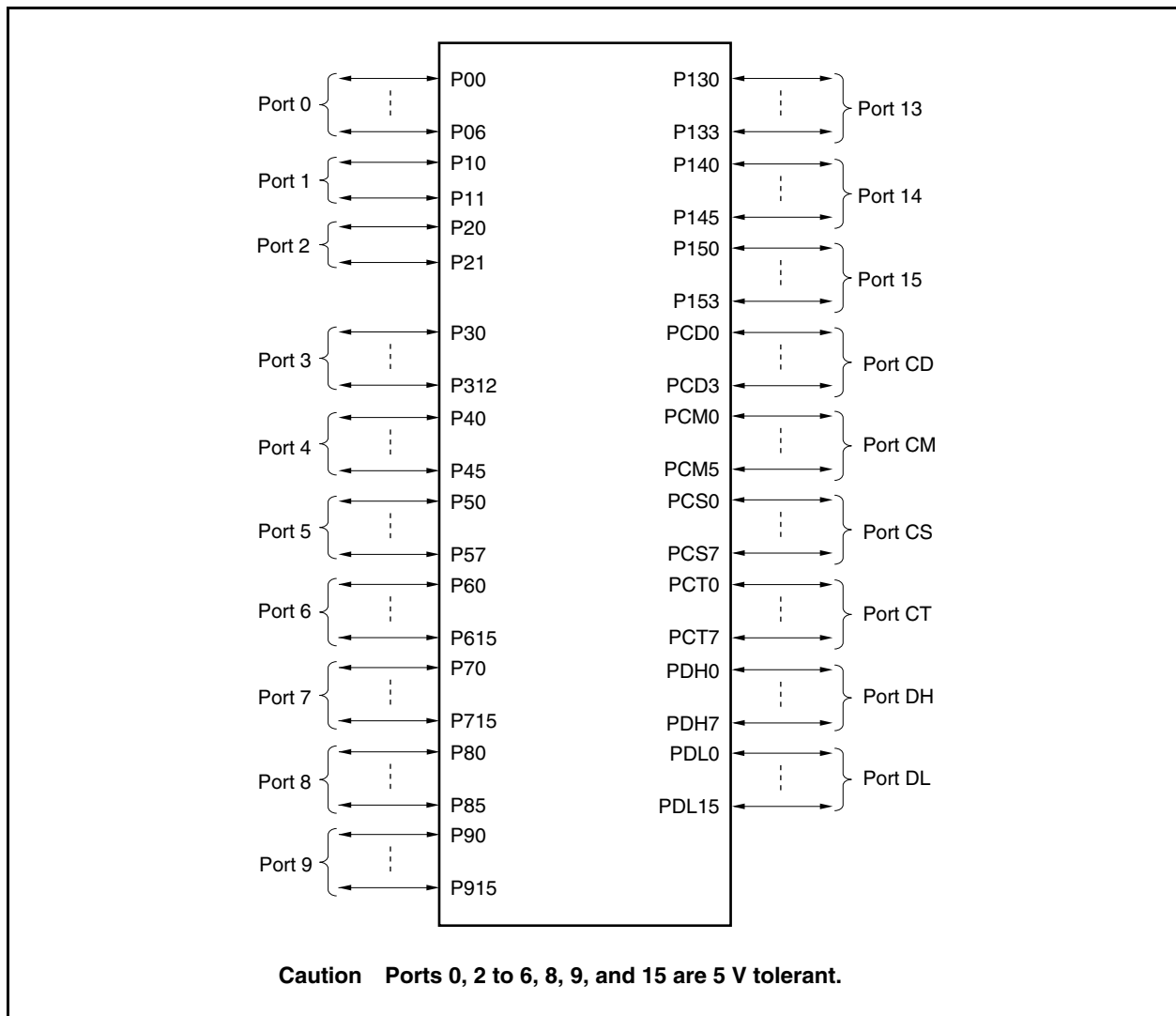

Table 4-2. I/O Buffer Power Supplies for Pins

Power Supply	Corresponding Pins
AV <sub>REF0</sub>	Port 7
AV <sub>REF1</sub>	Port 1
BV <sub>DD</sub>	Ports 13, 14, CD, CM, CS, CT, DH, DL
EV <sub>DD</sub>	$\overline{\text{RESET}}$ , ports 0, 2 to 6, 8, 9, 15

### 4.3 Port Configuration

**Table 4-3. Port Configuration (V850E/SJ3-H)**

Item	Configuration
Control register	Port n mode register (PMn: n = 0, 1, 3 to 9, CD, CM, CS, CT, DH, DL) Port n mode control register (PMCn: n = 0, 3 to 6, 8, 9, CD, CM, CS, CT, DH, DL) Port n function control register (PFCn: n = 0, 3 to 6, 8, 9, CD) Port n function control expansion register (PFCEn: n = 0 <sup>Note</sup> , 3, 5, 6, 8, 9) Port n function register (PFn: n = 0, 3 to 6, 8, 9)
Ports	I/O: 128

<R>

<R> **Note** The PFCE0 register is not included in the  $\mu$ PD70F3931, 70F3932, and 70F3933.

**Table 4-4. Port Configuration (V850E/SK3-H)**

Item	Configuration
Control register	Port n mode register (PMn: n = 0 to 9, 13 to 15, CD, CM, CS, CT, DH, DL) Port n mode control register (PMCn: n = 0, 2 to 6, 8, 9, 15, CD, CM, CS, CT, DH, DL) Port n function control register (PFCn: n = 0, 3 to 6, 8, 9, CD) Port n function control expansion register (PFCEn: n = 0, 3, 5, 6, 8, 9) Port n function register (PFn: n = 0, 2 to 6, 8, 9, 15)
Ports	I/O: 156

#### (1) Port n register (Pn)

Data is input from or output to an external device by writing or reading the Pn register.

The Pn register consists of a port latch that holds output data, and a circuit that reads the status of pins.

Each bit of the Pn register corresponds to one pin of port n, and can be read or written in 1-bit units.

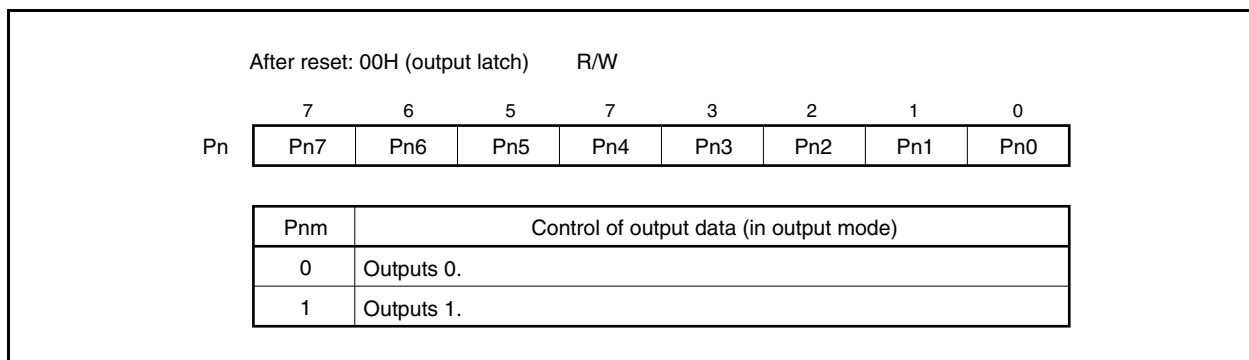

Data is written to or read from the Pn register as follows, regardless of the setting of the PMCn register.

**Table 4-5. Writing/Reading Pn Register**

Setting of PMn Register	Writing to Pn Register	Reading from Pn Register
Output mode (PMnm = 0)	Data is written to the output latch <sup>Note</sup> . In the port mode (PMCn = 0), the contents of the output latch are output from the pins.	The value of the output latch is read.
Input mode (PMnm = 1)	Data is written to the output latch. The pin status is not affected <sup>Note</sup> .	The pin status is read.

**Note** The value written to the output latch is retained until a new value is written to the output latch.

**(2) Port n mode register (PMn)**

The PMn register specifies the input or output mode of the corresponding port pin.

Each bit of this register corresponds to one pin of port n, and the input or output mode can be specified in 1-bit units.

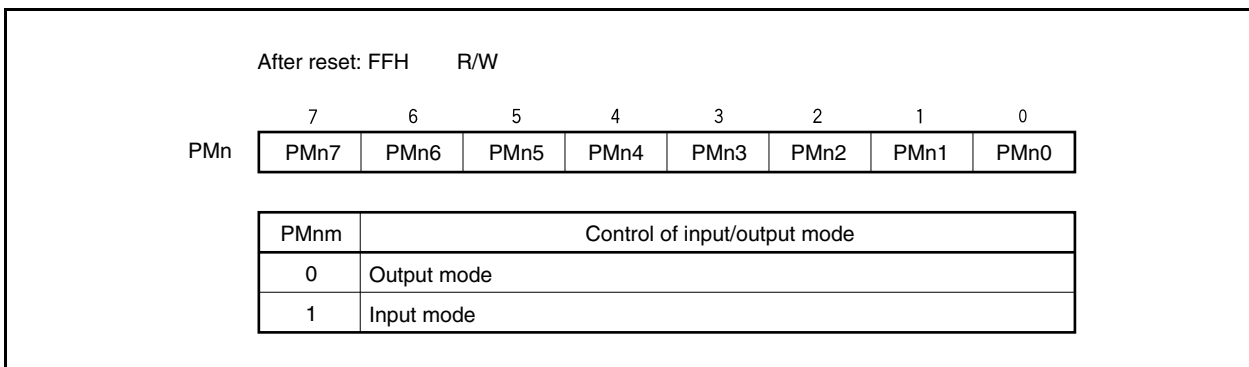

**(3) Port n mode control register (PMCn)**

The PMCn register specifies the port mode or alternate function.

Each bit of this register corresponds to one pin of port n, and the mode of the port can be specified in 1-bit units.

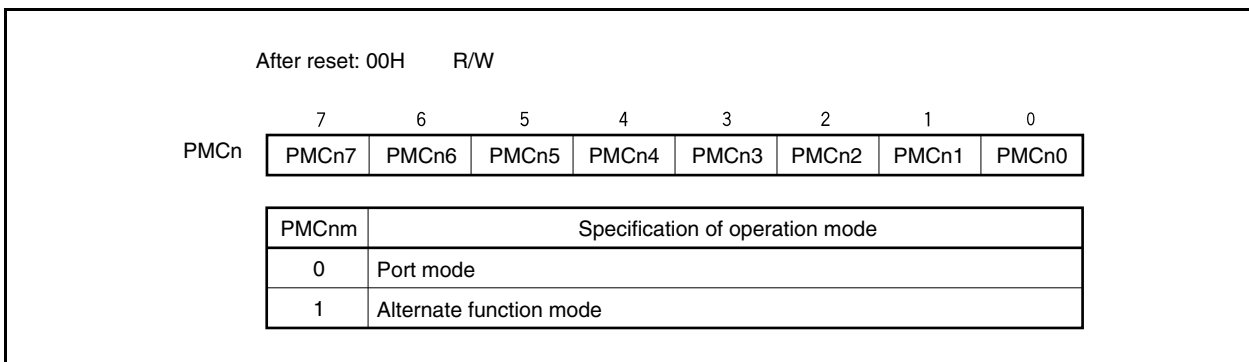

**(4) Port n function control register (PFCn)**

The PFCn register specifies the alternate function of a port pin to be used if the pin has two alternate functions. Each bit of this register corresponds to one pin of port n, and the alternate function of a port pin can be specified in 1-bit units.

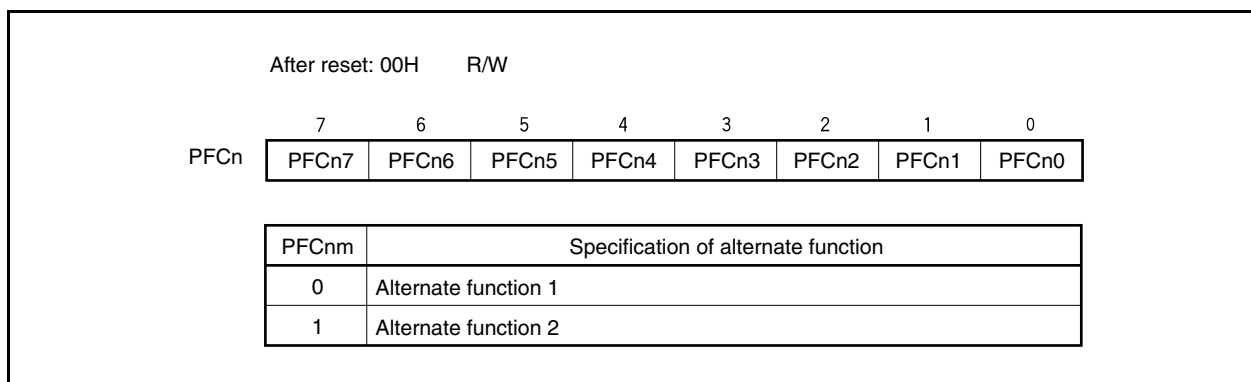

**(5) Port n function control expansion register (PFCEn)**

The PFCEn register specifies the alternate function of a port pin to be used if the pin has three or more alternate functions.

Each bit of this register corresponds to one pin of port n, and the alternate function of a port pin can be specified in 1-bit units.

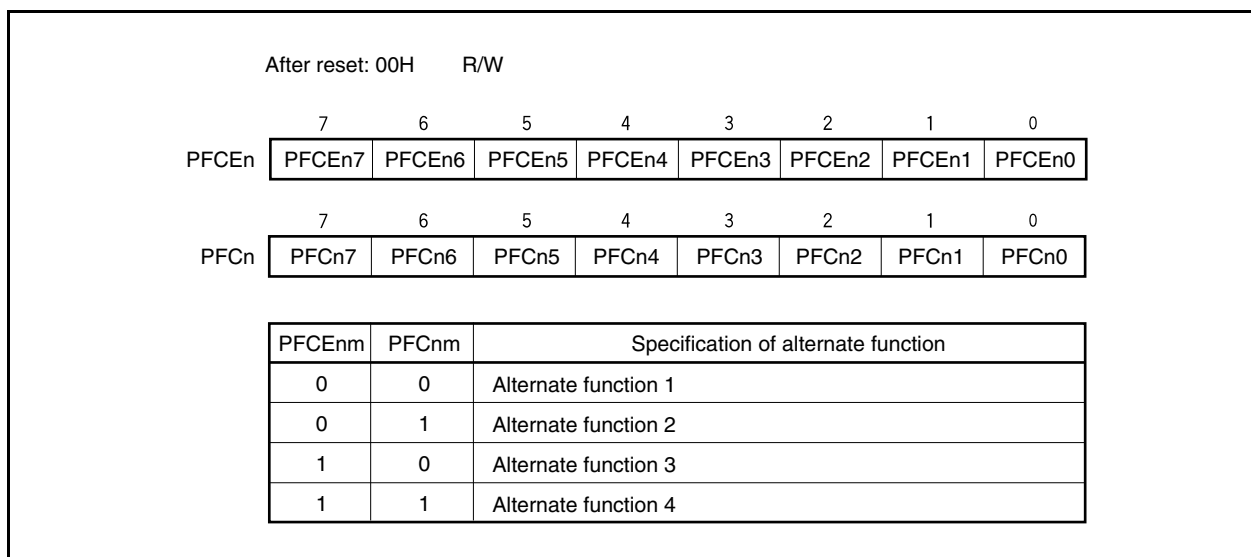

**(6) Port n function register (PFn)**

The PFn register specifies normal output or N-ch open-drain output.

Each bit of this register corresponds to one pin of port n, and the output mode of the port pin can be specified in 1-bit units.

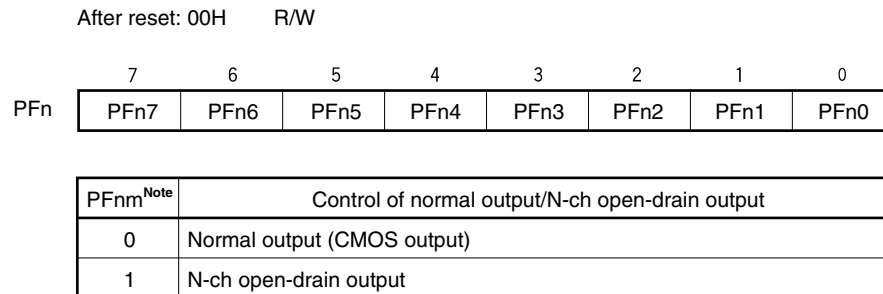

**Note** The PFnm bit of the PFn register is valid only when the PMnm bit of the PMn register is 0 (when the output mode is specified) in port mode (PMCnm bit = 0). When the PMnm bit is 1 (when the input mode is specified), the set value of the PFn register is invalid.

**(7) Port setting**

Set a port as illustrated below.

**Figure 4-3. Setting of Each Register and Pin Function**

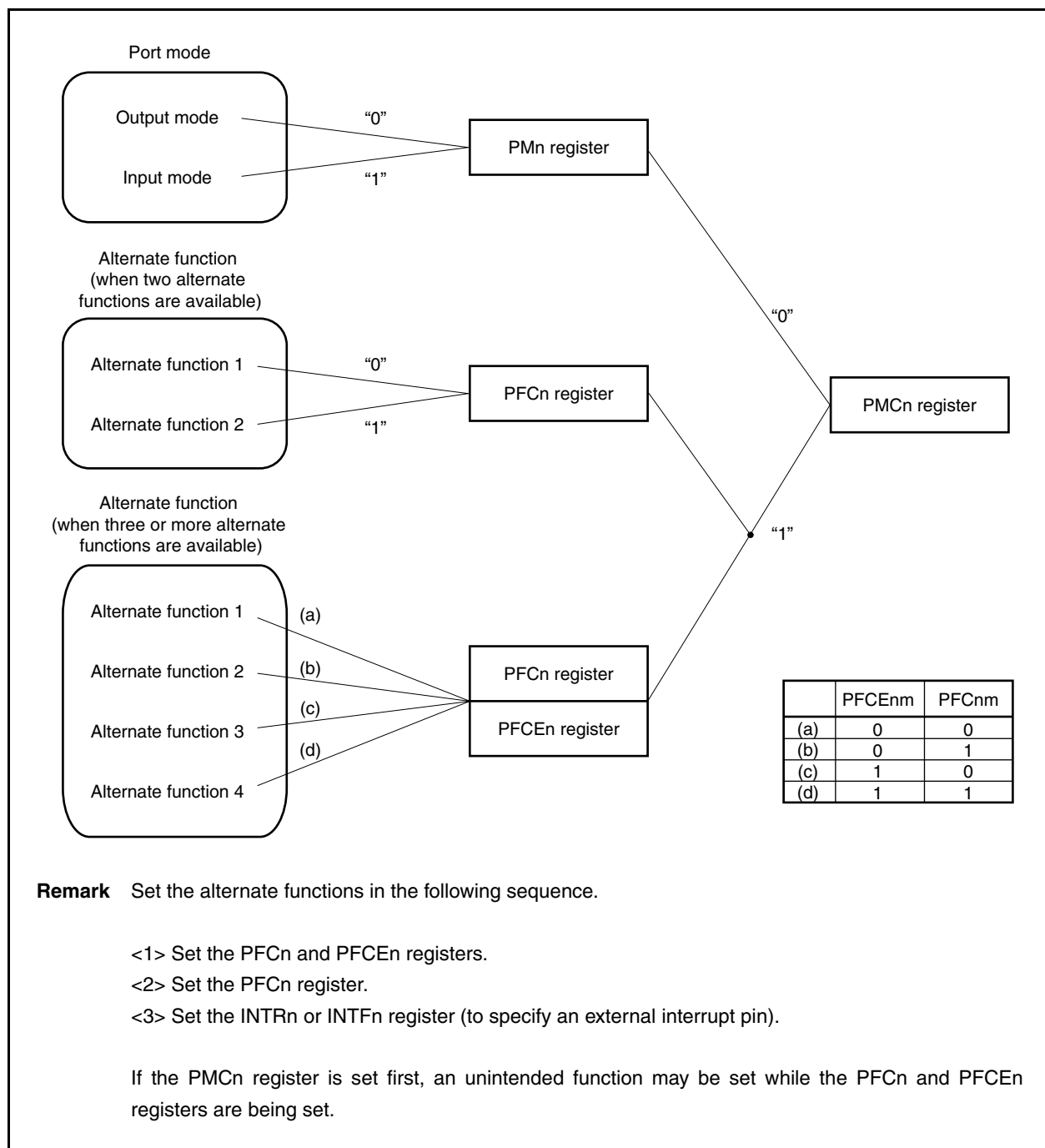

4.3.1 Port 0

Port 0 is a 7-bit port for which I/O settings can be controlled in 1-bit units.

Port 0 includes the following alternate-function pins.

Table 4-6. Port 0 Alternate-Function Pins

Pin Name	Pin No.		Alternate-Function Pin Name	I/O	Remark	Block Type
	SJ3-H	SK3-H				
	GJ	GM				
P00	6	6	TIP61/TOP61/SDA04 <sup>Note 1</sup>	I/O	Selectable as N-ch open-drain output	<b>Note 3</b>
P01	7	7	TIP60/TOP60/SCL04 <sup>Note 1</sup>	I/O		<b>Note 3</b>
P02	17	19	NMI	Input		L-1
P03	18	20	INTP0/ADTRG	Input		N-1
P04	19	21	INTP1	Input		L-1
P05	20	22	INTP2/ $\overline{\text{DRST}}$ <sup>Note 2</sup>	Input		AA-1
P06	21	23	INTP3	Input		L-1

<R>

<R>

<R>

<R>

**Notes 1.** The SDA04 and SCL04 pins are not included in the  $\mu$ PD70F3931 (V850E/SJ3-H), 70F3932 (V850E/SJ3-H), and 70F3933 (V850E/SJ3-H).

**2.** The  $\overline{\text{DRST}}$  pin is for on-chip debugging.

If on-chip debugging is not used, fix the P05/INTP2/ $\overline{\text{DRST}}$  pin to low level between when the reset signal of the  $\overline{\text{RESET}}$  pin is released and when the OCDM.OCDM0 bit is cleared (0).

For details, see **4.6.3 Cautions on on-chip debug pins.**

**3.** Product other than  $\mu$ PD70F3931 (V850E/SJ3-H), 70F3932 (V850E/SJ3-H), and 70F3933 (V850E/SJ3-H):

U-16

$\mu$ PD70F3931 (V850E/SJ3-H), 70F3932 (V850E/SJ3-H), and 70F3933 (V850E/SJ3-H): U-4

**Caution** The P00 to P06 pins have hysteresis characteristics in the input mode of the alternate function, but do not have hysteresis characteristics in the port mode.

**Remark** SJ3-H: V850E/SJ3-H

SK3-H: V850E/SK3-H

GJ (V850E/SJ3-H): 144-pin plastic LQFP (fine pitch) (20 × 20)

GM (V850E/SK3-H): 176-pin plastic LQFP (fine pitch) (24 × 24)

(1) Port 0 register (P0)

After reset: 00H (output latch)		R/W	Address: FFFFF400H					
	7	6	5	4	3	2	1	0
P0	0	P06	P05	P04	P03	P02	P01	P00
P0n	Output data control (in output mode) (n = 0 to 6)							
0	Outputs 0.							
1	Outputs 1.							

(2) Port 0 mode register (PM0)

After reset: FFH R/W Address: FFFFF420H

	7	6	5	4	3	2	1	0
PM0	1	PM06	PM05	PM04	PM03	PM02	PM01	PM00

PM0n	I/O mode control (n = 0 to 6)
0	Output mode
1	Input mode

(3) Port 0 mode control register (PMC0)

After reset: 00H R/W Address: FFFFF440H

	7	6	5	4	3	2	1	0
PMC0	0	PMC06	PMC05	PMC04	PMC03	PMC02	PMC01	PMC00

PMC06	Specification of P06 pin operation mode
0	I/O port
1	INTP3 input

PMC05	Specification of P05 pin operation mode
0	I/O port
1	INTP2 input

PMC04	Specification of P04 pin operation mode
0	I/O port
1	INTP1 input

PMC03	Specification of P03 pin operation mode
0	I/O port
1	INTP0 input/ADTRG input

PMC02	Specification of P02 pin operation mode
0	I/O port
1	NMI input

PMC01	Specification of P01 pin operation mode
0	I/O port
1	TIP60 input/TOP60 output/SCL04 <sup>Note</sup> I/O

PMC00	Specification of P00 pin operation mode
0	I/O port
1	TIP61 input/TOP61 output/SDA04 <sup>Note</sup> I/O

<R>

<R>

<R>

**Note** The SCL04 and SDA04 pins are not included in the  $\mu$ PD70F3931 (V850E/SJ3-H), 70F3932 (V850E/SJ3-H), and 70F3933 (V850E/SJ3-H).

**Caution** The P05/INTP2/ $\overline{\text{DRST}}$  pin becomes the  $\overline{\text{DRST}}$  pin regardless of the value of the PMC05 bit when the OCDM.OCDM0 bit = 1.



(4) Port 0 function control register (PFC0)

After reset: 00H R/W Address: FFFFF460H

	7	6	5	4	3	2	1	0
PFC0	0	0	0	0	PFC03	0	PFC01	PFC00

**Remark** For details of alternate function specification, see 4.3.1 (6) Port 0 alternate function specifications.

<R>

(5) Port 0 function control expansion register (PFCE0) (Not included in the  $\mu$ PD70F3931 (V850E/SJ3-H), 70F3932 (V850E/SJ3-H), and 70F3933 (V850E/SJ3-H).)

After reset: 00H R/W Address: FFFFF700H

	7	6	5	4	3	2	1	0
PFCE0	0	0	0	0	0	0	PFCE01	PFCE00

**Remark** For details of alternate function specification, see 4.3.1 (6) Port 0 alternate function specifications.

(6) Port 0 alternate function specifications.

PFC03	Specification of P03 pin alternate function
0	INTP0 input
1	ADTRG input

PFCE01	PFC01	Specification of P01 pin alternate function
0	0	TIP60 input
0	1	TOP60 output
1	0	SCL04 <sup>Note</sup> I/O
1	1	Setting prohibited

<R>

PFCE00	PFC00	Specification of P00 pin alternate function
0	0	TIP61 input
0	1	TOP61 output
1	0	SCL04 <sup>Note</sup> I/O
1	1	Setting prohibited

<R>

<R>

**Note** The SCL04 and SDA04 pins are not included in the  $\mu$ PD70F3931 (V850E/SJ3-H), 70F3932 (V850E/SJ3-H), and 70F3933 (V850E/SJ3-H).

## (7) Port 0 function register (PF0)

After reset: 00H R/W Address: FFFFFFFC60H

	7	6	5	4	3	2	1	0
PF0	0	PF06	PF05	PF04	PF03	PF02	PF01	PF00

PF0n	Control of normal output or N-ch open-drain output (n = 0 to 6)
0	Normal output (CMOS output)
1	N-ch open drain output

**Caution** To pull up an output pin at  $EV_{DD}$  or higher, be sure to set the appropriate PF0n bit to 1.

4.3.2 Port 1

Port 1 is a 2-bit port for which I/O settings can be controlled in 1-bit units.

Port 1 includes the following alternate-function pins.

Table 4-7. Port 1 Alternate-Function Pins

Pin Name	Pin No.		Alternate-Function Pin Name	I/O	Remark	Block Type
	SJ3-H	SK3-H				
	GJ	GM				
P10	3	3	ANO0	Output	–	A-2
P11	4	4	ANO1	Output	–	A-2

**Remark** SJ3-H: V850E/SJ3-H  
 SK3-H: V850E/SK3-H  
 GJ (V850E/SJ3-H): 144-pin plastic LQFP (fine pitch) (20 × 20)  
 GM (V850E/SK3-H): 176-pin plastic LQFP (fine pitch) (24 × 24)

(1) Port 1 register (P1)

After reset: 00H (output latch) R/W Address: FFFFF402H

	7	6	5	4	3	2	1	0
P1	0	0	0	0	0	0	P11	P10

P1n	Output data control (in output mode) (n = 0, 1)
0	Outputs 0
1	Outputs 1

**Caution** Do not read/write the P1 register during D/A conversion (see 15.4.3 Cautions).

(2) Port 1 mode register (PM1)

After reset: FFH R/W Address: FFFFF422H

	7	6	5	4	3	2	1	0
PM1	1	1	1	1	1	1	PM11	PM10

PM1n	I/O mode control (n = 0, 1)
0	Output mode
1	Input mode

**Cautions**

- When using P1n as alternate functions (ANOn pin output), set the PM1n bit to 1.
- When using one of the PM10 and PM11 pins as an I/O port and the other as a D/A output pin, do so in an application where the port I/O level does not change during D/A output.

**4.3.3 Port 2 (V850E/SK3-H only)**

Port 2 is a 2-bit port for which I/O settings can be controlled in 1-bit units.

Port 2 includes the following alternate-function pins.

**Table 4-8. Port 2 Alternate-Function Pins**

Pin Name	Pin No.		Alternate-Function Pin Name	I/O	Remark	Block Type
	SJ3-H	SK3-H				
	GJ	GM				
P20	–	8	SDA04	I/O	N-ch open-drain output selectable	E-3
P21	–	9	SCL04	I/O		E-3

**Caution** The P20 and P21 pins have hysteresis characteristics in the input mode of the alternate-function pin, but do not have the hysteresis characteristics in the port mode.

**Remark** SJ3-H: V850E/SJ3-H  
 SK3-H: V850E/SK3-H  
 GJ (V850E/SJ3-H): 144-pin plastic LQFP (fine pitch) (20 × 20)  
 GM (V850E/SK3-H): 176-pin plastic LQFP (fine pitch) (24 × 24)

**(1) Port 2 register (P2)**

After reset: 00H (output latch)		R/W	Address: FFFFF404H					
	7	6	5	4	3	2	1	0
P2	0	0	0	0	0	0	P21	P20
	Output data control (in output mode) (n = 0, 1)							
	P2n							
	0	Outputs 0.						
	1	Outputs 1.						

**(2) Port 2 mode register (PM2)**

After reset: FFH		R/W	Address: FFFFF424H					
	7	6	5	4	3	2	1	0
PM2	1	1	1	1	1	1	PM21	PM20
	I/O mode control (n = 0, 1)							
	PM2n							
	0	Output mode						
	1	Input mode						

**(3) Port 2 mode control register (PMC2)**

After reset: 00H    R/W    Address: FFFFF444H

	7	6	5	4	3	2	1	0
PMC2	0	0	0	0	0	0	PMC21	PMC20

PMC21	Specification of P21 pin operation mode
0	I/O port
1	SCL04 I/O

PMC20	Specification of P20 pin operation mode
0	I/O port
1	SDA04 I/O

**(4) Port 2 function register (PF2)**

After reset: 00H    R/W    Address: FFFFC64H

	7	6	5	4	3	2	1	0
PF2	0	0	0	0	0	0	PF21	PF20

PF2n	Control of normal output or N-ch open-drain output (n = 0, 1)
0	Normal output (CMOS output)
1	N-ch open-drain output

**Caution** To pull up an output pin at  $EV_{DD}$  or higher, be sure to set the appropriate PF2n bit to 1.

### 4.3.4 Port 3

Port 3 is a 10-bit (V850E/SJ3-H) or 13-bit (V850E/SK3-H) port for which I/O settings can be controlled in 1-bit units. Port 3 includes the following alternate-function pins.

**Table 4-9. Port 3 Alternate-Function Pins**

Pin Name	Pin No.		Alternate-Function Pin Name	I/O	Remark	Block Type
	SJ3-H	SK3-H				
	GJ	GM				
P30	25	30	TXDA0/SOB4	Output	Selectable as N-ch open-drain output	G-2
P31	26	31	RXDA0/INTP7/SIB4	Input		N-3
P32	27	32	ASCKA0/SCKB4/TIP00/TOP00	I/O		U-1
P33	28	33	TIP01/TOP01/CTXD1 <sup>Note 2</sup>	I/O		U-2
P34	29	34	TIP10/TOP10/CRXD1 <sup>Note 2</sup>	I/O		U-3
P35	30	35	TIP11/TOP11	I/O		U-4
P36	31	36	CTXD0 <sup>Note 3</sup> /IETX0	Output		G-2
P37	32	37	CRXD0 <sup>Note 3</sup> /IERX0	Input		G-3
P38	35	40	TXDA2/SDA00/SIB2	I/O		U-17
P39	36	41	RXDA2/SCL00/SCKB2	I/O		U-18
P310 <sup>Note 1</sup>	–	42	SOB2 <sup>Note 1</sup>	Output		U-19
P311 <sup>Note 1</sup>	–	43	TXDA2 <sup>Note 1</sup>	Output		E-2
P312 <sup>Note 1</sup>	–	44	RXDA2 <sup>Note 1</sup>	Input		E-1

- Notes 1.** V850E/SK3-H only
2. CAN controller (2-channel) version only
  3. CAN controller version only

**Caution** The P31 to P35, P37 to P39, and P312 pins have hysteresis characteristics in the input mode of the alternate-function pin, but do not have the hysteresis characteristics in the port mode.

**Remark** SJ3-H: V850E/SJ3-H  
 SK3-H: V850E/SK3-H  
 GJ (V850E/SJ3-H): 144-pin plastic LQFP (fine pitch) (20 × 20)  
 GM (V850E/SK3-H): 176-pin plastic LQFP (fine pitch) (24 × 24)

(1) Port 3 register (P3)

After reset: 0000H (output latch)    R/W    Address: P3 FFFFF406H,  
P3L FFFFF406H, P3H FFFFF407H

	15	14	13	12	11	10	9	8
P3 (P3H)	0	0	0	P312 <sup>Note</sup>	P311 <sup>Note</sup>	P310 <sup>Note</sup>	P39	P38
	7	6	5	4	3	2	1	0
(P3L)	P37	P36	P35	P34	P33	P32	P31	P30

P3n	Output data control (in output mode)
0	Outputs 0.
1	Outputs 1.

**Note** Valid for the V850E/SK3-H only.  
Be sure to clear this bit to 0 in the V850E/SJ3-H. However, the read value becomes undefined.

**Caution** Be sure to clear bits 13 to 15 to “0”.

**Remarks**

1. The P3 register can be read or written in 16-bit units.  
However, when using the higher 8 bits of the P3 register as the P3H register and the lower 8 bits as the P3L register, P3 can be read or written in 8-bit or 1-bit units.
2. To read/write bits 8 to 15 of the P3 register in 8-bit or 1-bit units, specify them as bits 0 to 7 of the P3H register.
3. V850E/SJ3-H: n = 0 to 9  
V850E/SK3-H: n = 0 to 12

(2) Port 3 mode register (PM3)

After reset: FFFFH R/W Address: PM3 FFFFF426H,  
 PM3L FFFFF426H, PM3H FFFFF427H

	15	14	13	12	11	10	9	8
PM3 (PM3H)	1	1	1	PM312 <sup>Note</sup>	PM311 <sup>Note</sup>	PM310 <sup>Note</sup>	PM39	PM38
(PM3L)	7	6	5	4	3	2	1	0
	PM37	PM36	PM35	PM34	PM33	PM32	PM31	PM30

PM3n	I/O mode control
0	Output mode
1	Input mode

**Note** Valid for the V850E/SK3-H only.  
 Be sure to set this bit to 1 in the V850E/SJ3-H.

**Caution** Be sure to set bits 13 to 15 to “1”.

- Remarks**
1. The PM3 register can be read or written in 16-bit units.  
 However, when using the higher 8 bits of the PM3 register as the PM3H register and the lower 8 bits as the PM3L register, PM3 can be read or written in 8-bit or 1-bit units.
  2. To read/write bits 8 to 15 of the PM3 register in 8-bit or 1-bit units, specify them as bits 0 to 7 of the PM3H register.
  3. V850E/SJ3-H: n = 0 to 9  
 V850E/SK3-H: n = 0 to 12



(3) Port 3 mode control register (PMC3)

(1/2)

After reset: 0000H R/W Address: PMC3 FFFFF446H,  
 PMC3L FFFFF446H, PMC3H FFFFF447H

	15	14	13	12	11	10	9	8
PMC3 (PMC3H)	0	0	0	PMC312 <sup>Note 1</sup>	PMC311 <sup>Note 1</sup>	PMC310 <sup>Note 1</sup>	PMC39	PMC38
	7	6	5	4	3	2	1	0
(PMC3L)	PMC37	PMC36	PMC35	PMC34	PMC33	PMC32	PMC31	PMC30

PMC312 <sup>Note 1</sup>	Specification of P312 pin operation mode
0	I/O port
1	RXDA2 <sup>Note 2</sup> input

PMC311 <sup>Note 1</sup>	Specification of P311 pin operation mode
0	I/O port
1	TXDA2 <sup>Note 2</sup> output

PMC310 <sup>Note 1</sup>	Specification of P310 pin operation mode
0	I/O port
1	SOB2 <sup>Note 2</sup> output

PMC39	Specification of P39 pin operation mode
0	I/O port
1	RXDA2 input/SCL00 I/O/ $\overline{\text{SCKB2}}$ I/O

PMC38	Specification of P38 pin operation mode
0	I/O port
1	TXDA2 output/SDA00 I/O/SIB2 input

PMC37	Specification of P37 pin operation mode
0	I/O port
1	CRXD0 <sup>Note 3</sup> input/ $\overline{\text{IERX0}}$ input

PMC36	Specification of P36 pin operation mode
0	I/O port
1	CTXD0 <sup>Note 3</sup> output/ $\overline{\text{IETX0}}$ output

PMC35	Specification of P35 pin operation mode
0	I/O port
1	TIP11 input/TOP11 output

- Notes**
- Valid for the V850E/SK3-H only.  
Be sure to clear this bit to 0 in the V850E/SJ3-H.
  - V850E/SK3-H only
  - CAN controller version only

**Caution** Be sure to clear bits 13 to 15 to "0".

PMC34	Specification of P34 pin operation mode
0	I/O port
1	TIP10 input/TOP10 output/CRXD1 <sup>Note</sup> input
PMC33	Specification of P33 pin operation mode
0	I/O port
1	TIP01 input/TOP01 output/CTXD1 <sup>Note</sup> output
PMC32	Specification of P32 pin operation mode
0	I/O port
1	ASCKA0 input/SCKB4 I/O/TIP00 input/TOP00 output
PMC31	Specification of P31 pin operation mode
0	I/O port
1	RXDA0 input/INTP7 input/SIB4 input
PMC30	Specification of P30 pin operation mode
0	I/O port
1	TXDA0 output/SOB4 output

**Note** CAN controller (2-channel) version only

- Remarks**
1. The PMC3 register can be read or written in 16-bit units.  
However, when using the higher 8 bits of the PMC3 register as the PMC3H register and the lower 8 bits as the PMC3L register, PMC3 can be read or written in 8-bit or 1-bit units.
  2. To read/write bits 8 to 15 of the PMC3 register in 8-bit or 1-bit units, specify them as bits 0 to 7 of the PMC3H register.

**(4) Port 3 function control register (PFC3)**

After reset: 0000H    R/W    Address: PFC3 FFFFF466H,  
PFC3L FFFFF466H, PFC3L FFFFF467H

	15	14	13	12	11	10	9	8
PFC3 (PFC3H)	0	0	0	0	0	PFC310 <sup>Note</sup>	PFC39	PFC38
	7	6	5	4	3	2	1	0
(PFC3L)	PFC37	PFC36	PFC35	PFC34	PFC33	PFC32	PFC31	PFC30

**Note** Valid for the V850E/SK3-H only.  
Be sure to clear this bit to 0 in the V850E/SJ3-H.

**Caution** Be sure to clear bits 11 to 15 to “0”.

**Remarks**

- For details of alternate function specification, see 4.3.4 (6) Port 3 alternate function specifications.
- The PFC3 register can be read or written in 16-bit units.  
However, when using the higher 8 bits of the PFC3 register as the PFC3H register and the lower 8 bits as the PFC3L register, PFC3 can be read or written in 8-bit and 1-bit units.
- To read/write bits 8 to 15 of the PFC3 register in 8-bit or 1-bit units, specify them as bits 0 to 7 of the PFC3H register.

**(5) Port 3 function control expansion register (PFCE3)**

After reset: 0000H    R/W    Address: PFCE3 FFFFF706H,  
PFCE3L FFFFF706H, PFCE3H FFFFF707H

	15	14	13	12	11	10	9	8
PFCE3 (PFCE3H)	0	0	0	0	0	PFCE310 <sup>Note</sup>	PFCE39	PFCE38
	7	6	5	4	3	2	1	0
(PFCE3L)	0	0	0	PFCE34	PFCE33	PFCE32	0	0

**Note** Valid for the V850E/SK3-H only.  
Be sure to clear this bit to 0 in the V850E/SJ3-H.

**Caution** Be sure to clear bits 0, 1, 5 to 7, and 11 to 15 to “0”.

**Remark** For details of alternate function specification, see 4.3.4 (6) Port 3 alternate function specifications.

(6) Port 3 alternate function specifications

PFCE310	PFC310	Specification of P310 pin alternate function
1	0	SOB2 <sup>Note 1</sup> output
Other than above		Setting prohibited

PFCE39	PFC39	Specification of P39 pin alternate function
0	0	RXDA2 input
0	1	SCL00 I/O
1	0	SCKB2 I/O
1	1	Setting prohibited

PFCE38	PFC38	Specification of P38 pin alternate function
0	0	TXDA2 output
0	1	SDA00 I/O
1	0	SIB2 input
1	1	Setting prohibited

PFC37	Specification of P37 pin alternate function
0	CRXD0 <sup>Note 2</sup> input
1	I $\bar$ ERX0 input

PFC36	Specification of P36 pin alternate function
0	CTXD0 <sup>Note 2</sup> output
1	IETX0 output

PFC35	Specification of P35 pin alternate function
0	TIP11 input
1	TOP11 output

- Notes 1.** V850E/SK3-H only  
**2.** CAN controller version only

PFCE34	PFC34	Specification of P34 pin alternate function
0	0	TIP10 input
0	1	TOP10 output
1	0	CRXD1 <sup>Note 1</sup> input
1	1	Setting prohibited

PFCE33	PFC33	Specification of P33 pin alternate function
0	0	TIP01 input
0	1	TOP01 output
1	0	CTXD1 <sup>Note 1</sup> output
1	1	Setting prohibited

PFCE32	PFC32	Specification of P32 pin alternate function
0	0	ASCKA0 input
0	1	SCKB4 I/O
1	0	TIP00 input
1	1	TOP00 output

PFC31	Specification of P31 pin alternate function
0	RXDA0 input/INTP7 <sup>Note 2</sup> input
1	SIB4 input

PFC30	Specification of P30 pin alternate function
0	TXDA0 output
1	SOB4 output

**Notes 1.** CAN controller (2-channel) version only

**2.** The INTP7 pin and RXDA0 pin are alternate-function pins. When using the pin as the RXDA0 pin, disable edge detection for the INTP7 alternate-function pin. (Clear the INTF3.INTF31 bit and the INTR3.INTR31 bit to 0.) When using the pin as the INTP7 pin, stop UARTA0 reception. (Clear the UA0CTL0.UA0RXE bit to 0.)

(7) Port 3 function register (PF3)

After reset: 0000H R/W Address: PF3 FFFFFFFC66H,  
PF3L FFFFFFFC66H, PF3H FFFFFFFC67H

	15	14	13	12	11	10	9	8
PF3 (PF3H)	0	0	0	PF312 <sup>Note</sup>	PF311 <sup>Note</sup>	PF310 <sup>Note</sup>	PF39	PF38

	7	6	5	4	3	2	1	0
(PF3L)	PF37	PF36	PF35	PF34	PF33	PF32	PF31	PF30

PF3n	Control of normal output or N-ch open-drain output
0	Normal output (CMOS output)
1	N-ch open-drain output

**Note** Valid for the V850E/SK3-H only.  
Be sure to clear this bit to 0 in the V850E/SJ3-H.

**Cautions** 1. To pull up an output pin at  $EV_{DD}$  or higher, be sure to set the appropriate PF3n bit to 1.  
2. Be sure to clear bits 13 to 15 to “0”.

**Remarks** 1. The PF3 register can be read or written in 16-bit units.  
However, when using the higher 8 bits of the PF3 register as the PF3H register and the lower 8 bits as the PF3L register, PF3 can be read or written in 8-bit or 1-bit units.  
2. To read/write bits 8 to 15 of the PF3 register in 8-bit or 1-bit units, specify them as bits 0 to 7 of the PF3H register.  
3. V850E/SJ3-H: n = 0 to 9  
V850E/SK3-H: n = 0 to 12

### 4.3.5 Port 4

Port 4 is a 3-bit (V850E/SJ3-H) or 6-bit (V850E/SK3-H) port that controls I/O in 1-bit units.

Port 4 includes the following alternate-function pins.

**Table 4-10. Port 4 Alternate-Function Pins**

Pin Name	Pin No.		Alternate-Function Pin Name	I/O	Remark	Block Type
	SJ3-H	SK3-H				
	GJ	GM				
P40	22	24	SIB0/SDA01	I/O	Selectable as N-ch open-drain output	G-5
P41	23	25	SOB0/SCL01	I/O		G-6
P42	24	26	SCKB0/INTP2	I/O		N-4
P43 <sup>Note</sup>	–	27	–	–		C-1
P44 <sup>Note</sup>	–	28	$\overline{\text{IETX0}}$ <sup>Note</sup>	Output		E-2
P45 <sup>Note</sup>	–	29	$\overline{\text{IERX0}}$ <sup>Note</sup>	Input		E-1

**Note** V850E/SK3-H only

**Caution** The P40 to P42 and 45 pins have hysteresis characteristics in the input mode of the alternate-function pin, but do not have the hysteresis characteristics in the port mode.

**Remark** SJ3-H: V850E/SJ3-H  
 SK3-H: V850E/SK3-H  
 GJ (V850E/SJ3-H): 144-pin plastic LQFP (fine pitch) (20 × 20)  
 GM (V850E/SK3-H): 176-pin plastic LQFP (fine pitch) (24 × 24)

(1) Port 4 register (P4)

After reset: 00H (output latch) R/W Address: FFFFF408H

	7	6	5	4	3	2	1	0
P4	0	0	P45 <sup>Note</sup>	P44 <sup>Note</sup>	P43 <sup>Note</sup>	P42	P41	P40

P4n	Output data control (in output mode)
0	Outputs 0.
1	Outputs 1.

**Note** Valid for the V850E/SK3-H only.

Be sure to clear this bit to 0 in the V850E/SJ3-H. However, the read value becomes undefined.

**Caution** Be sure to clear bits 6 and 7 to “0”.

**Remark** V850E/SJ3-H: n = 0 to 2  
 V850E/SK3-H: n = 0 to 5

(2) Port 4 mode register (PM4)

After reset: FFH R/W Address: FFFFF428H

	7	6	5	4	3	2	1	0
PM4	1	1	PM45 <sup>Note</sup>	PM44 <sup>Note</sup>	PM43 <sup>Note</sup>	PM42	PM41	PM40

PM4n	I/O mode control
0	Output mode
1	Input mode

**Note** Valid for the V850E/SK3-H only.

Be sure to set this bit to 1 in the V850E/SJ3-H.

**Caution** Be sure to set bits 6 and 7 to “1”.

**Remark** V850E/SJ3-H: n = 0 to 2  
 V850E/SK3-H: n = 0 to 5



(3) Port 4 mode control register (PMC4)

After reset: 00H R/W Address: FFFFF448H

	7	6	5	4	3	2	1	0
PMC4	0	0	PMC45 <sup>Note 1</sup>	PMC44 <sup>Note 1</sup>	0	PMC42	PMC41	PMC40

PMC45 <sup>Note 1</sup>	Specification of P45 pin operation mode
0	I/O port
1	$\overline{\text{IERX0}}$ <sup>Note 2</sup> input

PMC44 <sup>Note 1</sup>	Specification of P44 pin operation mode
0	I/O port
1	$\overline{\text{IERX0}}$ <sup>Note 2</sup> output

PMC42	Specification of P42 pin operation mode
0	I/O port
1	$\overline{\text{SCKB0}}$ I/O/INTP2 input

PMC41	Specification of P41 pin operation mode
0	I/O port
1	SOB0 output/SCL01 I/O

PMC40	Specification of P40 pin operation mode
0	I/O port
1	SIB0 input/SDA01 I/O

- Notes**
- Valid for the V850E/SK3-H only.  
Be sure to clear this bit to 0 in the V850E/SJ3-H.
  - V850E/SK3-H only

**Caution** Be sure to clear bits 3, 6, and 7 to “0”.

(4) Port 4 function control register (PFC4)

After reset: 00H R/W Address: FFFFF468H

	7	6	5	4	3	2	1	0
PFC4	0	0	0	0	0	PFC42	PFC41	PFC40

PFC42	Specification of P42 pin alternate function
0	SCKB0 I/O
1	INTP2 input

PFC41	Specification of P41 pin alternate function
0	SOB0 output
1	SCL01 I/O

PFC40	Specification of P40 pin alternate function
0	SIB0 input
1	SDA01 I/O

**Caution** Be sure to clear bits 3 to 7 to “0”.

(5) Port 4 function register (PF4)

After reset: 00H R/W Address: FFFFFC68H

	7	6	5	4	3	2	1	0
PF4	0	0	PF45 <sup>Note</sup>	PF44 <sup>Note</sup>	PF43 <sup>Note</sup>	PF42	PF41	PF40

PF4n	Control of normal output or N-ch open-drain output
0	Normal output (CMOS output)
1	N-ch open-drain output

**Note** Valid for the V850E/SK3-H only.  
Be sure to clear this bit to 0 in the V850E/SJ3-H.

**Cautions**

1. To pull up an output pin at EV<sub>DD</sub> or higher, be sure to set the appropriate PF4n bit to 1.
2. Be sure to clear bits 6 and 7 to “0”.

**Remark** V850E/SJ3-H: n = 0 to 2  
V850E/SK3-H: n = 0 to 5

### 4.3.6 Port 5

Port 5 is a 6-bit (V850E/SJ3-H) or 8-bit (V850E/SK3-H) port that controls I/O in 1-bit units.

Port 5 includes the following alternate-function pins.

**Table 4-11. Port 5 Alternate-Function Pins**

Pin Name	Pin No.		Alternate-Function Pin Name	I/O	Remark	Block Type
	SJ3-H	SK3-H				
	GJ	GM				
P50	37	45	KR0/TIQ01/TOQ01/RTP00	I/O	Selectable as N-ch open-drain output	U-5
P51	38	46	INTP7/KR1/TIQ02/TOQ02/RTP01	I/O		U-20
P52	39	47	KR2/TIQ03/TOQ03/RTP02/DDI <sup>Note 1</sup>	I/O		U-6
P53	40	48	SIB2/KR3/TIQ00/TOQ00/RTP03/DDO <sup>Note 1</sup>	I/O		U-7
P54	41	49	SOB2/KR4/RTP04/DCK <sup>Note 1</sup>	I/O		U-8
P55	42	50	SCKB2/KR5/RTP05/DMS <sup>Note 1</sup>	I/O		U-9
P56 <sup>Note 2</sup>	–	51	RXDA4 <sup>Note 2</sup>	Input		E-1
P57 <sup>Note 2</sup>	–	52	TXDA4 <sup>Note 2</sup>	Output	E-2	

**Notes 1.** The DDI, DDO, DCK, and DMS pins are for on-chip debugging.

If on-chip debugging is not used, fix the P05/INTP2/DRST pin to low level between when the reset signal of the RESET pin is released and when the OCDM.OCDM0 bit is cleared (0).

For details, see **4.6.3 Cautions on on-chip debug pins.**

**2.** V850E/SK3-H only

**Cautions 1.** When the power is turned on, the P53 pin may momentarily output an undefined level.

**2.** The P50 to P56 pins have hysteresis characteristics in the input mode of the alternate function, but do not have hysteresis characteristics in the port mode.

**Remark** SJ3-H: V850E/SJ3-H

SK3-H: V850E/SK3-H

GJ (V850E/SJ3-H): 144-pin plastic LQFP (fine pitch) (20 × 20)

GM (V850E/SK3-H): 176-pin plastic LQFP (fine pitch) (24 × 24)

(1) Port 5 register (P5)

After reset: 00H (output latch) R/W Address: FFFFF40AH

	7	6	5	4	3	2	1	0
P5	P57 <sup>Note</sup>	P56 <sup>Note</sup>	P55	P54	P53	P52	P51	P50

P5n	Output data control (in output mode)
0	Outputs 0.
1	Outputs 1.

**Note** Valid for the V850E/SK3-H only.  
 Be sure to clear this bit to 0 in the V850E/SJ3-H. However, the read value becomes undefined.

**Remark** V850E/SJ3-H: n = 0 to 5  
 V850E/SK3-H: n = 0 to 7

(2) Port 5 mode register (PM5)

After reset: FFH R/W Address: FFFFF42AH

	7	6	5	4	3	2	1	0
PM5	PM57 <sup>Note</sup>	PM56 <sup>Note</sup>	PM55	PM54	PM53	PM52	PM51	PM50

PM5n	I/O mode control
0	Output mode
1	Input mode

**Note** Valid for the V850E/SK3-H only.  
 Be sure to set this bit to 1 in the V850E/SJ3-H.

**Remark** V850E/SJ3-H: n = 0 to 5  
 V850E/SK3-H: n = 0 to 7

(3) Port 5 mode control register (PMC5)

After reset: 00H R/W Address: FFFF44AH

	7	6	5	4	3	2	1	0
PMC5	PMC57 <sup>Note 1</sup>	PMC56 <sup>Note 1</sup>	PMC55	PMC54	PMC53	PMC52	PMC51	PMC50
	Specification of P57 pin operation mode							
	0	I/O port						
	1	TXDA4 <sup>Note 2</sup> output						
	Specification of P56 pin operation mode							
	0	I/O port						
	1	RXDA4 <sup>Note 2</sup> input						
	Specification of P55 pin operation mode							
	0	I/O port						
	1	SCKB2 I/O/KR5 input/RTP05 output						
	Specification of P54 pin operation mode							
	0	I/O port						
	1	SOB2 output/KR4 input/RTP04 output						
	Specification of P53 pin operation mode							
	0	I/O port						
	1	SIB2 input/KR3 input/TIQ00 input/TOQ00 output/RTP03 output						
	Specification of P52 pin operation mode							
	0	I/O port						
	1	KR2 input/TIQ03 input/TOQ03 output/RTP02 output						
	Specification of P51 pin operation mode							
	0	I/O port						
	1	INTP7 input/KR1 input/TIQ02 input/TOQ02 output/RTP01 output						
	Specification of P50 pin operation mode							
	0	I/O port						
	1	KR0 input/TIQ01 input/TOQ01 output/RTP00 output						

- Notes**
- Valid for the V850E/SK3-H only.  
Be sure to clear this bit to 0 in the V850E/SJ3-H.
  - V850E/SK3-H only

**(4) Port 5 function control register (PFC5)**

After reset: 00H R/W Address: FFFFF46AH

	7	6	5	4	3	2	1	0
PFC5	0	0	PFC55	PFC54	PFC53	PFC52	PFC51	PFC50

**Remark** For details of alternate function specification, see 4.3.6 (6) **Port 5 alternate function specifications.**

**(5) Port 5 function control expansion register (PFCE5)**

After reset: 00H R/W Address: FFFFF70AH

	7	6	5	4	3	2	1	0
PFCE5	0	0	PFCE55	PFCE54	PFCE53	PFCE52	PFCE51	PFCE50

**Remark** For details of alternate function specification, see 4.3.6 (6) **Port 5 alternate function specifications.**

**(6) Port 5 alternate function specifications**

PFCE55	PFC55	Specification of P55 pin alternate function
0	0	SCKB2 I/O
0	1	KR5 input
1	0	Setting prohibited
1	1	RTP05 output

PFCE54	PFC54	Specification of P54 pin alternate function
0	0	SOB2 output
0	1	KR4 input
1	0	Setting prohibited
1	1	RTP04 output

PFCE53	PFC53	Specification of P53 pin alternate function
0	0	SIB2 input
0	1	KR3 <sup>Note</sup> input/TIQ00 input
1	0	TOQ00 output
1	1	RTP03 output

PFCE52	PFC52	Specification of P52 pin alternate function
0	0	Setting prohibited
0	1	KR2 <sup>Note</sup> input/TIQ03 input
1	0	TOQ03 input
1	1	RTP02 output

PFCE51	PFC51	Specification of P51 pin alternate function
0	0	INTP7 input
0	1	KR1 <sup>Note</sup> input/TIQ02 input
1	0	TOQ02 output
1	1	RTP01 output

PFCE50	PFC50	Specification of P50 pin alternate function
0	0	Setting prohibited
0	1	KR0 <sup>Note</sup> input/TIQ01 input
1	0	TOQ01 output
1	1	RTP00 output

**Note** The KRn pin and TIQ0m pin are alternate-function pins. When using the pin as the TIQ0m pin, disable KRn pin key return detection, which is the alternate function. (Clear the KRM.KRMn bit to 0.) Also, when using the pin as the KRn pin, disable TIQ0m pin edge detection, which is the alternate function (n = 0 to 3, m = 0 to 3).

Pin Name	Use as TIQ0m Pin	Use as KRn Pin
KR0/TIQ01	KRM.KRM0 bit = 0	TQ0IOC1.TQ0IS3, TQ0IS2 bits = 00
KR1/TIQ02	KRM.KRM1 bit = 0	TQ0IOC1.TQ0IS5, TQ0IS4 bits = 00
KR2/TIQ03	KRM.KRM2 bit = 0	TQ0IOC1.TQ0IS7, TQ0IS6 bits = 00
KR3/TIQ00	KRM.KRM3 bit = 0	TQ0IOC1.TQ0IS1, TQ0IS0 bits = 00 TQ0IOC2.TQ0EES1, TQ0EES0 bits = 00 TQ0IOC2.TQ0ETS1, TQ0ETS0 bits = 00

## (7) Port 5 function register (PF5)

After reset: 00H R/W Address: FFFFFFFC6AH

	7	6	5	4	3	2	1	0
PF5	PF57 <sup>Note</sup>	PF56 <sup>Note</sup>	PF55	PF54	PF53	PF52	PF51	PF50

PF5n	Control of normal output or N-ch open-drain output
0	Normal output (CMOS output)
1	N-ch open-drain output

**Note** Valid for the V850E/SK3-H only.

Be sure to clear this bit to 0 in the V850E/SJ3-H.

**Caution** To pull up an output pin at  $EV_{DD}$  or higher, be sure to set the appropriate PF5n bit to 1.

**Remark** V850E/SJ3-H: n = 0 to 5

V850E/SK3-H: n = 0 to 7



4.3.7 Port 6

Port 6 is a 16-bit port for which I/O settings can be controlled in 1-bit units.

Port 6 includes the following alternate-function pins.

Table 4-12. Port 6 Alternate-Function Pins

Pin Name	Pin No.		Alternate-Function Pin Name	I/O	Remark	Block Type
	SJ3-H	SK3-H				
	GJ	GM				
<R> P60	43	53	RTP10/RXDA4/SIE0 <sup>Note 1</sup>	I/O	Selectable as N-ch open-drain output	Note 2
<R> P61	44	54	RTP11/TXDA4/SOE0 <sup>Note 1</sup>	Output		Note 2
<R> P62	45	55	RTP12/SCKE0 <sup>Note 1</sup>	I/O		Note 2
<R> P63	46	56	RTP13/SIE1 <sup>Note 1</sup> /KR4	I/O		Note 2
<R> P64	47	57	RTP14/SOE1 <sup>Note 1</sup> /KR5	I/O		Note 2
<R> P65	48	58	RTP15/SCKE1 <sup>Note 1</sup> /KR2/TIQ03/TOQ03	I/O		Note 2
P66	49	59	SIB5/INTP9/KR3/TIQ00/TOQ00	I/O		U-26
<R> P67	50	60	SOB5/RXDA5/SDA05 <sup>Note 1</sup>	I/O		Note 2
<R> P68	51	61	SCKB5/TXDA5/SCL05 <sup>Note 1</sup>	I/O		Note 2
P69	52	62	TIP70/TOP70/TENC70	I/O		U-29
P610	53	63	TIP71/TENC71	Input		U-30
P611	54	64	TOP71/TECR7	I/O		U-31
P612	55	65	TIP80/TOP80/TENC80	I/O		U-29
P613	56	66	TIP81/TOP81/TENC81	I/O		U-29
P614	57	67	SDA03/TECR8	I/O		U-32
P615	58	68	SCL03	I/O		E-3

<R> **Notes 1.** These pins are not included in the  $\mu$ PD70F3931 (V850E/SJ3-H), 70F3932 (V850E/SJ3-H), and 70F3933 (V850E/SJ3-H).

<R> **2.** Block types differ for each product.

- Products other than  $\mu$ PD70F3931 (V850E/SJ3-H), 70F3932 (V850E/SJ3-H), and 70F3933 (V850E/SJ3-H)

Pin name	P60	P61	P62	P63	P64	P65	P67	P68
Block type	U-21	U-22	U-38	U-23	U-24	U-25	U-27	U-28

•  $\mu$ PD70F3931 (V850E/SJ3-H), 70F3932 (V850E/SJ3-H), and 70F3933 (V850E/SJ3-H)

Pin name	P60	P61	P62	P63	P64	P65	P67	P68
Block type	G-1	G-2	E-2	U-36	U-36	U-37	G-1	G-7

**Caution** The P60 and P62 to P615 pins have hysteresis characteristics in the input mode of the alternate-function pin, but do not have the hysteresis characteristics in the port mode.

**Remark** SJ3-H: V850E/SJ3-H  
 SK3-H: V850E/SK3-H  
 GJ (V850E/SJ3-H): 144-pin plastic LQFP (fine pitch) (20 × 20)  
 GM (V850E/SK3-H): 176-pin plastic LQFP (fine pitch) (24 × 24)

(1) Port 6 register (P6)

After reset: 0000H (output latch) R/W Address: P6 FFFF40CH  
 P6L FFFF40CH, P6LH FFFF40DH

	15	14	13	12	11	10	9	8
P6 (P6H)	P615	P614	P613	P612	P611	P610	P69	P68
	7	6	5	4	3	2	1	0
(P6L)	P67	P66	P65	P64	P63	P62	P61	P60
P6n	Output data control (in output mode) (n = 0 to 15)							
0	Outputs 0.							
1	Outputs 1.							

- Remarks**
- The P6 register can be read or written in 16-bit units.  
 However, when using the higher 8 bits of the P6 register as the P6H register and the lower 8 bits as the P6L register, P6 can be read or written in 8-bit or 1-bit units.
  - To read/write bits 8 to 15 of the P6 register in 8-bit or 1-bit units, specify them as bits 0 to 7 of the P6H register.

(2) Port 6 mode register (PM6)

After reset: FFFFH R/W Address: PM6 FFFF42CH  
 PM6L FFFF42CH, PM6H FFFF42DH

	15	14	13	12	11	10	9	8
PM6 (PM6H)	PM615	PM614	PM613	PM612	PM611	PM610	PM69	PM68
	7	6	5	4	3	2	1	0
(PM6L)	PM67	PM66	PM65	PM64	PM63	PM62	PM61	PM60
PM6n	I/O mode control (n = 0 to 15)							
0	Output mode							
1	Input mode							

- Remarks**
- The PM6 register can be read or written in 16-bit units.  
 However, when using the higher 8 bits of the PM6 register as the PM6H register and the lower 8 bits as the PM6L register, PM6 can be read or written in 8-bit or 1-bit units.
  - To read/write bits 8 to 15 of the PM6 register in 8-bit or 1-bit units, specify them as bits 0 to 7 of the PM6H register.

(3) Port 6 mode control register (PMC6)

(1/2)

After reset: 0000H R/W Address: PMC6 FFFF44CH  
 PMC6L FFFF44CH, PMC6H FFFF44DH

	15	14	13	12	11	10	9	8
PMC6 (PMC6H)	PMC615	PMC614	PMC613	PMC612	PMC611	PMC610	PMC69	PMC68

	7	6	5	4	3	2	1	0
(PMC6L)	PMC67	PMC66	PMC65	PMC64	PMC63	PMC62	PMC61	PMC60

PMC615	Specification of P615 pin operation mode
0	I/O port
1	SCL03 I/O

PMC614	Specification of P614 pin operation mode
0	I/O port
1	SDA03 I/O/TECR8 input

PMC613	Specification of P613 pin operation mode
0	I/O port
1	TIP81 input/TOP81 output/TENC81 input

PMC612	Specification of P612 pin operation mode
0	I/O port
1	TIP80 input/TOP80 output/TENC80 input

PMC611	Specification of P611 pin operation mode
0	I/O port
1	TOP71 output/TECR7 input

PMC610	Specification of P610 pin operation mode
0	I/O port
1	TIP71 input/TENC71 input

PMC69	Specification of P69 pin operation mode
0	I/O port
1	TIP70 input/TOP70 output/TENC70 input

PMC68	Specification of P68 pin operation mode
0	I/O port
1	SCKB5 I/O/TXDA5 output/SCL05 <sup>Note</sup> I/O

<R>

PMC67	Specification of P67 pin operation mode
0	I/O port
1	SOB5 output/RXDA5 input/SDA05 <sup>Note</sup> I/O

<R>

PMC66	Specification of P66 pin operation mode
0	I/O port
1	SIB5 input/INTP9 input/KR3 input/TIQ00 input/TOQ00 output

PMC65	Specification of P65 pin operation mode
0	I/O port
1	RTP15 output/SKE1 <sup>Note</sup> I/O/KR2 input/TIQ03 input/TOQ03 output

<R>

<R>

**Note** Not available in the  $\mu$ PD70F3931 (V850E/SJ3-H), 70F3932 (V850E/SJ3-H), and 70F3933 (V850E/SJ3-H).

&lt;R&gt;

PMC64	Specification of P64 pin operation mode
0	I/O port
1	RTP14 output/SOE1 <sup>Note</sup> output/KR5 input

&lt;R&gt;

PMC63	Specification of P63 pin operation mode
0	I/O port
1	RTP13 output/SIE1 <sup>Note</sup> input/KR4 input

&lt;R&gt;

PMC62	Specification of P62 pin operation mode
0	I/O port
1	RTP12 output/SCKE0 <sup>Note</sup> I/O

&lt;R&gt;

PMC61	Specification of P61 pin operation mode
0	I/O port
1	RTP11 output/TXDA4 output/SOE0 <sup>Note</sup> output

&lt;R&gt;

PMC60	Specification of P60 pin operation mode
0	I/O port
1	RTP10 output/RXDA4 input/SIE0 <sup>Note</sup> input

&lt;R&gt;

**Note** Not available in the  $\mu$ PD70F3931 (V850E/SJ3-H), 70F3932 (V850E/SJ3-H), and 70F3933 (V850E/SJ3-H).

**Remarks 1.** The PMC6 register can be read or written in 16-bit units.

However, when using the higher 8 bits of the PMC6 register as the PMC6H register and the lower 8 bits as the PMC6L register, PMC6 can be read or written in 8-bit or 1-bit units.

**2.** To read/write bits 8 to 15 of the PMC6 register in 8-bit or 1-bit units, specify them as bits 0 to 7 of the PMC6H register.

**(4) Port 6 function control register (PFC6)**

After reset: 0000H R/W Address: PFC6 FFFFF46CH,  
PFC6L FFFFF46CH, PFC6H FFFFF46DH

	15	14	13	12	11	10	9	8
PFC6 (PFC6H)	0	PFC614	PFC613	PFC612	PFC611	PFC610	PFC69	PFC68
	7	6	5	4	3	2	1	0
(PFC6L)	PFC67	PFC66	PFC65	PFC64	PFC63	PFC62 <sup>Note</sup>	PFC61	PFC60

<R>

<R>

**Note** Not available in the  $\mu$ PD70F3931 (V850E/SJ3-H), 70F3932 (V850E/SJ3-H), and 70F3933 (V850E/SJ3-H).

Be sure to clear this bit to 0 in the  $\mu$ PD70F3931 (V850E/SJ3-H), 70F3932 (V850E/SJ3-H), and 70F3933 (V850E/SJ3-H).

**Caution** Be sure to clear bit 15 to “0”.

**Remarks 1.** For details of alternate function specification, see **4.3.7 (6) Port 6 alternate function specifications**.

**2.** The PFC6 register can be read or written in 16-bit units.

However, when using the higher 8 bits of the PFC6 register as the PFC6H register and the lower 8 bits as the PFC6L register, PFC6 can be read or written in 8-bit or 1-bit units.

**3.** To read/write bits 8 to 15 of the PFC6 register in 8-bit or 1-bit units, specify them as bits 0 to 7 of the PFC6H register.

**(5) Port 6 function control expansion register (PFCE6)**

After reset: 0000H R/W Address: PFCE6 FFFFF70CH,  
PFCE6L FFFFF70CH, PFCE6H FFFFF70DH

	15	14	13	12	11	10	9	8
PFCE6 (PFCE6H)	0	PFCE614	PFCE613	PFCE612	PFCE611	PFCE610	PFCE69	PFCE68 <sup>Note</sup>
	7	6	5	4	3	2	1	0
(PFCE6L)	PFCE67 <sup>Note</sup>	PFCE66	PFCE65	PFCE64	PFCE63	PFCE62 <sup>Note</sup>	PFCE61 <sup>Note</sup>	PFCE60 <sup>Note</sup>

<R>

<R>

<R>

**Note** Not available in the  $\mu$ PD70F3931 (V850E/SJ3-H), 70F3932 (V850E/SJ3-H), and 70F3933 (V850E/SJ3-H).

Be sure to clear this bit to 0 in the  $\mu$ PD70F3931 (V850E/SJ3-H), 70F3932 (V850E/SJ3-H), and 70F3933 (V850E/SJ3-H).

**Caution** Be sure to clear bit 15 to “0”.

**Remark** For details of alternate function specification, see **4.3.7 (6) Port 6 alternate function specifications**.

(6) Port 6 alternate function specifications

PFCE614	PFC614	Specification of P614 pin alternate function
0	0	SDA03 I/O
0	1	Setting prohibited
1	0	TECR8 input
1	1	Setting prohibited

PFCE613	PFC613	Specification of P613 pin alternate function
0	0	TIP81 input
0	1	TOP81 output
1	0	TENC81 input
1	1	Setting prohibited

PFCE612	PFC612	Specification of P612 pin alternate function
0	0	TIP80 input
0	1	TOP80 output
1	0	TENC80 input
1	1	Setting prohibited

PFCE611	PFC611	Specification of P611 pin alternate function
0	0	TOP71 output
0	1	Setting prohibited
1	0	TECR7 input
1	1	Setting prohibited

PFCE610	PFC610	Specification of P610 pin alternate function
0	0	TIP71 input
0	1	Setting prohibited
1	0	TENC71 input
1	1	Setting prohibited

PFCE69	PFC69	Specification of P69 pin alternate function
0	0	TIP70 input
0	1	TOP70 output
1	0	TENC70 input
1	1	Setting prohibited

<R>

PFCE68 <sup>Note 1</sup>	PFC68	Specification of P68 pin alternate function
0	0	SCKB5 I/O
0	1	TXDA5 output
1	0	SCL05 <sup>Note 2</sup> I/O
1	1	Setting prohibited

<R>

PFCE67 <sup>Note 1</sup>	PFC67	Specification of P67 pin alternate function
0	0	SOB5 output
0	1	RXDA5 input
1	0	SDA05 <sup>Note 2</sup> I/O
1	1	Setting prohibited

PFCE66	PFC66	Specification of P66 pin alternate function
0	0	SIB5 input
0	1	INTP9 input
1	0	KR3 <sup>Note 3</sup> input/TIQ00 input
1	1	TOQ00 output

PFCE65	PFC65	Specification of P65 pin alternate function
0	0	RTP15 output
0	1	$\overline{\text{SCKE1}}$ <sup>Note 2</sup> I/O
1	0	KR2 <sup>Note 3</sup> input/TIQ03 input
1	1	TOQ03 output

PFCE64	PFC64	Specification of P64 pin alternate function
0	0	RTP14 output
0	1	SOE1 <sup>Note 2</sup> output
1	0	KR5 input
1	1	Setting prohibited

PFCE63	PFC63	Specification of P63 pin alternate function
0	0	RTP13 output
0	1	SIE1 <sup>Note 2</sup> input
1	0	KR4 input
1	1	Setting prohibited

PFCE62 <sup>Note 1</sup>	PFC62 <sup>Note 1</sup>	Specification of P62 pin alternate function
0	0	RTP12 output
0	1	Setting prohibited
1	0	$\overline{\text{SCKE0}}$ <sup>Note 2</sup> I/O
1	1	Setting prohibited

PFCE61 <sup>Note 1</sup>	PFC61	Specification of P61 pin alternate function
0	0	RTP11 output
0	1	TXDA4 output
1	0	SOE0 <sup>Note 2</sup> output
1	1	Setting prohibited

<R>	PFCE60 <sup>Note 1</sup>	PFC60	Specification of P60 pin alternate function
	0	0	RTP10 output
	0	1	RXDA4 input
<R>	1	0	SIE0 <sup>Note 2</sup> input
	1	1	Setting prohibited

<R> **Notes 1.** Valid for other than the  $\mu$ PD70F3931 (V850E/SJ3-H), 70F3932 (V850E/SJ3-H), and 70F3933 (V850E/SJ3-H) only.

Be sure to clear this bit to 0 in the  $\mu$ PD70F3931 (V850E/SJ3-H), 70F3932 (V850E/SJ3-H), and 70F3933 (V850E/SJ3-H).

2. Not available in the  $\mu$ PD70F3931 (V850E/SJ3-H), 70F3932 (V850E/SJ3-H), and 70F3933 (V850E/SJ3-H)
3. The KRn pin and TIQ0m pin are alternate-function pins. When using the pin as the TIQ0m pin, disable KRn pin key return detection, which is the alternate function. (Clear the KRM.KRMn bit to 0.) Also, when using the pin as the KRn pin, disable TIQ0m pin edge detection, which is the alternate function (n = 2, 3, m = 0, 3).

Pin Name	Used as TIQ0m Pin	Used as KRn Pin
KR2/TIQ03	KRM.KRM2 bit = 0	TQ0IOC1.TQ0IS7, TQ0IS6 bits = 00
KR3/TIQ00	KRM.KRM3 bit = 0	TQ0IOC1.TQ0IS1, TQ0IS0 bits = 00 TQ0IOC2.TQ0EES1, TQ0EES0 bits = 00 TQ0IOC2.TQ0ETS1, TQ0ETS0 bits = 00

(7) Port 6 function register (PF6)

After reset: 0000H R/W Address: PF6 FFFFFFFC6CH  
PF6L FFFFFFFC6DH, PF6H FFFFFFFC6DH

PF6 (PF6H)	15	14	13	12	11	10	9	8
	PF615	PF614	PF613	PF612	PF611	PF610	PF69	PF68
(PF6L)	7	6	5	4	3	2	1	0
	PF67	PF66	PF65	PF64	PF63	PF62	PF61	PF60

PF6n	Normal output/N-ch open-drain output control (n = 0 to 15)
0	Normal output (CMOS output)
1	N-ch open-drain output

**Caution** To pull up an output pin at EV<sub>DD</sub> or higher, be sure to set the appropriate PF6n bit to 1.

- Remarks**
1. The PF6 register can be read or written in 16-bit units. However, when using the higher 8 bits of the PF6 register as the PF6H register and the lower 8 bits as the PF6L register, PF6 can be read or written in 8-bit and 1-bit units.
  2. To read/write bits 8 to 15 of the PF6 register in 8-bit or 1-bit units, specify them as bits 0 to 7 of the PF6H register.



### 4.3.8 Port 7

Port 7 is a 16-bit port for which I/O settings can be controlled in 1-bit units.

Port 7 includes the following alternate-function pins.

**Table 4-13. Port 7 Alternate-Function Pins**

Pin Name	Pin No.		Alternate-Function Pin Name	I/O	Remark	Block Type
	SJ3-H	SK3-H				
	GJ	GM				
P70	144	176	ANI0	Input	-	A-1
P71	143	175	ANI1	Input		A-1
P72	142	174	ANI2	Input		A-1
P73	141	173	ANI3	Input		A-1
P74	140	172	ANI4	Input		A-1
P75	139	171	ANI5	Input		A-1
P76	138	170	ANI6	Input		A-1
P77	137	169	ANI7	Input		A-1
P78	136	168	ANI8	Input		A-1
P79	135	167	ANI9	Input		A-1
P710	134	166	ANI10	Input		A-1
P711	133	165	ANI11	Input		A-1
P712	132	164	ANI12	Input		A-1
P713	131	163	ANI13	Input		A-1
P714	130	162	ANI14	Input		A-1
P715	129	161	ANI15	Input		A-1

**Remark** SJ3-H: V850E/SJ3-H

SK3-H: V850E/SK3-H

GJ (V850E/SJ3-H): 144-pin plastic LQFP (fine pitch) (20 × 20)

GM (V850E/SK3-H): 176-pin plastic LQFP (fine pitch) (24 × 24)

(1) Port 7 register H, port 7 register L (P7H, P7L)

After reset: 00H (output latch) R/W Address: P7L FFFF40EH, P7H FFFF40FH

	7	6	5	4	3	2	1	0
P7H	P715	P714	P713	P712	P711	P710	P79	P78

	7	6	5	4	3	2	1	0
P7L	P77	P76	P75	P74	P73	P72	P71	P70

P7n	Output data control (in output mode) (n = 0 to 15)
0	Outputs 0.
1	Outputs 1.

**Caution** Do not read/write the P7H and P7L registers during A/D conversion (see 13.6 (4) Alternate I/O).

**Remark** These registers cannot be accessed in 16-bit units as the P7 register. They can be read or written in 8-bit or 1-bit units as the P7H and P7L registers.

(2) Port 7 mode register H, port 7 mode register L (PM7H, PM7L)

After reset: FFH R/W Address: PM7L FFFF42EH, PM7H FFFF42FH

	7	6	5	4	3	2	1	0
PM7H	PM715	PM714	PM713	PM712	PM711	PM710	PM79	PM78

	7	6	5	4	3	2	1	0
PM7L	PM77	PM76	PM75	PM74	PM73	PM72	PM71	PM70

PM7n	I/O mode control (n = 0 to 15)
0	Output mode
1	Input mode

**Caution** When using the P7n pin as its alternate function (ANIn pin), set the PM7n bit to 1.

**Remark** These registers cannot be accessed in 16-bit units as the PM7 register. They can be read or written in 8-bit or 1-bit units as the PM7H and PM7L registers.

4.3.9 Port 8

Port 8 is a 2-bit (V850E/SJ3-H) or 6-bit (V850E/SK3-H) port for which I/O settings can be controlled in 1-bit units. Port 8 includes the following alternate-function pins.

Table 4-14. Port 8 Alternate-Function Pins

Pin Name	Pin No.		Alternate-Function Pin Name	I/O	Remark	Block Type
	SJ3-H	SK3-H				
	GJ	GM				
P80	59	71	RXDA3/INTP8/RC1CK1HZ	I/O	Selectable as N-ch open-drain output	U-33
P81	60	72	TXDA3/RC1CKO/RC1CKDIV	Output		U-34
P82 <sup>Note</sup>	–	73	SDA05 <sup>Note</sup>	I/O		E-3
P83 <sup>Note</sup>	–	74	SCL05 <sup>Note</sup>	I/O		E-3
P84 <sup>Note</sup>	–	75	RXDA5 <sup>Note</sup>	Input		E-1
P85 <sup>Note</sup>	–	76	TXDA5 <sup>Note</sup>	Output		E-2

**Note** V850E/SK3-H only.

**Caution** The P80 and P82 to P84 pins have hysteresis characteristics in the input mode of the alternate-function pin, but do not have the hysteresis characteristics in the port mode.

**Remark** SJ3-H: V850E/SJ3-H  
 SK3-H: V850E/SK3-H  
 GJ (V850E/SJ3-H): 144-pin plastic LQFP (fine pitch) (20 × 20)  
 GM (V850E/SK3-H): 176-pin plastic LQFP (fine pitch) (24 × 24)

(1) Port 8 register (P8)

After reset: 00H (output latch)    R/W    Address: FFFFF410H

P8	7	6	5	4	3	2	1	0
	0	0	P85 <sup>Note</sup>	P84 <sup>Note</sup>	P83 <sup>Note</sup>	P82 <sup>Note</sup>	P81	P80

P8n	Output data control
0	Outputs 0.
1	Outputs 1.

**Note** Valid for the V850E/SK3-H only.  
 Be sure to clear this bit to 0 in the V850E/SJ3-H. However, the read value becomes undefined.

**Caution** Be sure to clear bits 6 and 7 to “0”.

**Remark** V850E/SJ3-H: n = 0, 1  
 V850E/SK3-H: n = 0 to 5

(2) Port 8 mode register (PM8)

After reset: FFH R/W Address: FFFFF430H

	7	6	5	4	3	2	1	0
PM8	1	1	PM85 <sup>Note</sup>	PM84 <sup>Note</sup>	PM83 <sup>Note</sup>	PM82 <sup>Note</sup>	PM81	PM80

PM8n	I/O mode control
0	Output mode
1	Input mode

**Note** Valid for the V850E/SK3-H only.  
Be sure to set this bit to 1 in the V850E/SJ3-H.

**Caution** Be sure to set bits 6 and 7 to “1”.

**Remark** V850E/SJ3-H: n = 0, 1  
V850E/SK3-H: n = 0 to 5

(3) Port 8 mode control register (PMC8)

After reset: 00H R/W R/W Address: FFFFF450H

	7	6	5	4	3	2	1	0
PMC8	0	0	PMC85 <sup>Note 1</sup>	PMC84 <sup>Note 1</sup>	PMC83 <sup>Note 1</sup>	PMC82 <sup>Note 1</sup>	PMC81	PMC80
PMC85 <sup>Note 1</sup>	Specification of P85 pin operation mode							
0	I/O port							
1	TXDA5 <sup>Note 2</sup> output							
PMC84 <sup>Note 1</sup>	Specification of P84 pin operation mode							
0	I/O port							
1	RXDA5 <sup>Note 2</sup> input							
PMC83 <sup>Note 1</sup>	Specification of P83 pin operation mode							
0	I/O port							
1	SCL05 <sup>Note 2</sup> I/O							
PMC82 <sup>Note 1</sup>	Specification of P82 pin operation mode							
0	I/O port							
1	SDA05 <sup>Note 2</sup> I/O							
PMC81	Specification of P81 pin operation mode							
0	I/O port							
1	TXDA3 output/RC1CKO output/RC1CKDIV output							
PMC80	Specification of P80 pin operation mode							
0	I/O port							
1	RXDA3 input/INTP8 <sup>Note 3</sup> input/RC1CK1HZ output							

**Notes 1.** Valid for the V850E/SK3-H only.

Be sure to set this bit to 0 in the V850E/SJ3-H.

**2.** V850E/SK3-H only

**3.** The INTP8 and RXDA3 pins are alternate-function pins. When using the RXDA3 pin, disable detection of the edge of the INTP8 pin (INTF8.INTF80 bit = 0 and INTR8.INTR80 bit = 0). When using the INTP8 pin, stop the reception operation of UARTA3 (UA3CTL0.UA3RXE bit = 0).

**Caution** Be sure to clear bits 6 and 7 to “0”.

**(4) Port 8 function control register (PFC8)**

After reset: 00H    R/W    Address: FFFFF470H

	7	6	5	4	3	2	1	0
PFC8	0	0	0	0	0	0	PFC81	PFC80

**Remark** For details of alternate function specification, see **4.3.9 (6) Port 8 alternate function specifications.**

**(5) Port 8 function control expansion register (PFCE8)**

After reset: 00H    R/W    Address: FFFFF710H

	7	6	5	4	3	2	1	0
PFCE8	0	0	0	0	0	0	PFCE81	PFCE80

**Remark** For details of alternate function specification, see **4.3.9 (6) Port 8 alternate function specifications.**

**(6) Port 8 alternate function specifications**

PFCE81	PFC81	Specification of P81 pin alternate function
0	0	TXDA3 output
0	1	Setting prohibited
1	0	RC1CKO output /RC1CKDIV output
1	1	Setting prohibited

PFCE80	PFC80	Specification of P80 pin alternate function
0	0	RXDA3 input /INTP8 input
0	1	Setting prohibited
1	0	RC1CK1HZ output
1	1	Setting prohibited

(7) Port 8 function register (PF8)

After reset: 00H R/W Address: FFFFC70H

	7	6	5	4	3	2	1	0
PF8	0	0	PF85 <sup>Note</sup>	PF84 <sup>Note</sup>	PF83 <sup>Note</sup>	PF82 <sup>Note</sup>	PF81	PF80

PF8n	Control of normal output or N-ch open-drain output
0	Normal output (CMOS output)
1	N-ch open-drain output

**Note** Valid for the V850E/SK3-H only.  
Be sure to clear this bit to 0 in the V850E/SJ3-H.

**Cautions** 1. To pull up an output pin at  $EV_{DD}$  or higher, be sure to set the appropriate PF8n bit to 1.  
2. Be sure to clear bits 6 and 7 to “0”.

**Remark** V850E/SJ3-H: n = 0, 1  
V850E/SK3-H: n = 0 to 5

## 4.3.10 Port 9

Port 9 is a 16-bit port for which I/O settings can be controlled in 1-bit units.

Port 9 includes the following alternate-function pins.

Table 4-15. Port 9 Alternate-Function Pins

Pin Name	Pin No.		Alternate-Function Pin Name	I/O	Remark	Block Type
	SJ3-H	SK3-H				
	GJ	GM				
P90	61	77	A0/KR6/TXDA1/SDA02	I/O	Selectable as N-ch open-drain output	U-10
P91	62	78	A1/KR7/RXDA1/SCL02	I/O		U-11
P92	63	79	A2/TIP41/TOP41	I/O		U-12
P93	64	80	A3/TIP40/TOP40/INTP8	I/O		U-35
P94	65	81	A4/TIP31/TOP31	I/O		U-12
P95	66	82	A5/TIP30/TOP30/INTP5	I/O		U-35
P96	67	83	A6/TIP21/TOP21	I/O		U-13
P97	68	84	A7/SIB1/TIP20/TOP20	I/O		U-14
P98	69	85	A8/SOB1	Output		G-2
P99	70	86	A9/ $\overline{\text{SCKB1}}$	I/O		G-4
P910	71	87	A10/SIB3	I/O		G-1
P911	72	88	A11/SOB3	Output		G-2
P912	73	89	A12/ $\overline{\text{SCKB3}}$	I/O		G-4
P913	74	90	A13/INTP4	I/O		N-2
P914	75	91	A14/INTP5/TIP51/TOP51	I/O		U-15
P915	76	92	A15/INTP6/TIP50/TOP50	I/O	U-15	

**Caution** The P90 to P97, P99, P910, and P912 to P915 pins have hysteresis characteristics in the input mode of the alternate-function pin, but do not have the hysteresis characteristics in the port mode.

**Remark** SJ3-H: V850E/SJ3-H  
 SK3-H: V850E/SK3-H  
 GJ (V850E/SJ3-H): 144-pin plastic LQFP (fine pitch) (20 × 20)  
 GM (V850E/SK3-H): 176-pin plastic LQFP (fine pitch) (24 × 24)



(1) Port 9 register (P9)

After reset: 0000H (output latch) R/W Address: P9 FFFFF412H,  
P9L FFFFF412H, P9H FFFFF413H

	15	14	13	12	11	10	9	8
P9 (P9H)	P915	P914	P913	P912	P911	P910	P99	P98

	7	6	5	4	3	2	1	0
(P9L)	P97	P96	P95	P94	P93	P92	P91	P90

P9n	Output data control (in output mode) (n = 0 to 15)
0	Outputs 0.
1	Outputs 1.

**Remarks**

1. The P9 register can be read or written in 16-bit units.  
However, when using the higher 8 bits of the P9 register as the P9H register and the lower 8 bits as the P9L register, P9 can be read or written in 8-bit or 1-bit units.
2. To read/write bits 8 to 15 of the P9 register in 8-bit or 1-bit units, specify them as bits 0 to 7 of the P9H register.

(2) Port 9 mode register (PM9)

After reset: FFFFH R/W Address: PM9 FFFFF432H,  
PM9L FFFFF432H, PM9H FFFFF433H

	15	14	13	12	11	10	9	8
PM9 (PM9H)	PM915	PM914	PM913	PM912	PM911	PM910	PM99	PM98

	7	6	5	4	3	2	1	0
(PM9L)	PM97	PM96	PM95	PM94	PM93	PM92	PM91	PM90

PM9n	I/O mode control (n = 0 to 15)
0	Output mode
1	Input mode

**Remarks**

1. The PM9 register can be read or written in 16-bit units.  
However, when using the higher 8 bits of the PM9 register as the PM9H register and the lower 8 bits as the PM9L register, PM9 can be read or written in 8-bit and 1-bit units.
2. To read/write bits 8 to 15 of the PM9 register in 8-bit or 1-bit units, specify them as bits 0 to 7 of the PM9H register.

(3) Port 9 mode control register (PMC9)

(1/2)

After reset: 0000H R/W Address: PMC9 FFFF452H, PMC9L FFFF452H, PMC9H FFFF453H

	15	14	13	12	11	10	9	8
PMC9 (PMC9H)	PMC915	PMC914	PMC913	PMC912	PMC911	PMC910	PMC99	PMC98

	7	6	5	4	3	2	1	0
(PMC9L)	PMC97	PMC96	PMC95	PMC94	PMC93	PMC92	PMC91	PMC90

PMC915	Specification of P915 pin operation mode
0	I/O port
1	A15 output/INTP6 input/TIP50 input/TOP50 output

PMC914	Specification of P914 pin operation mode
0	I/O port
1	A14 output/INTP5 input/TIP51 input/TOP51 output

PMC913	Specification of P913 pin operation mode
0	I/O port
1	A13 output/INTP4 input

PMC912	Specification of P912 pin operation mode
0	I/O port
1	A12 output/SCKB3 I/O

PMC911	Specification of P911 pin operation mode
0	I/O port
1	A11 output/SOB3 output

PMC910	Specification of P910 pin operation mode
0	I/O port
1	A10 output/SIB3 input

PMC99	Specification of P99 pin operation mode
0	I/O port
1	A9 output/SCKB1 I/O

- Remarks**
- The PMC9 register can be read or written in 16-bit units. However, when using the higher 8 bits of the PMC9 register as the PMC9H register and the lower 8 bits as the PMC9L register, PMC9 can be read or written in 8-bit or 1-bit units.
  - To read/write bits 8 to 15 of the PMC9 register in 8-bit or 1-bit units, specify them as bits 0 to 7 of the PMC9H register.

PMC98	Specification of P98 pin operation mode
0	I/O port
1	A8 output/SOB1 output
PMC97	Specification of P97 pin operation mode
0	I/O port
1	A7 output/SIB1 input/TIP20 input/TOP20 output
PMC96	Specification of P96 pin operation mode
0	I/O port
1	A6 output/TIP21 input/TOP21 output
PMC95	Specification of P95 pin operation mode
0	I/O port
1	A5 output/TIP30 input/TOP30 output/INTP5 input
PMC94	Specification of P94 pin operation mode
0	I/O port
1	A4 output/TIP31 input/TOP31 output
PMC93	Specification of P93 pin operation mode
0	I/O port
1	A3 output/TIP40 input/TOP40 output/INTP8 input
PMC92	Specification of P92 pin operation mode
0	I/O port
1	A2 output/TIP41 input/TOP41 output
PMC91	Specification of P91 pin operation mode
0	I/O port
1	A1 output/KR7 input/RXDA1 input/KR7 input/SCL02 I/O
PMC90	Specification of P90 pin operation mode
0	I/O port
1	A0 output/KR6 input/TXDA1 output/SDA02 I/O

**Caution** Port 9 pins cannot be used as port pins or other alternate-function pins if even one of the A0 to A15 pins is used in the separate bus mode. After setting the PFC9 and PFCE9 registers to 0000H, therefore, set all 16 bits of the PMC9 register to FFFFH at once. If none of the A0 to A15 pins is used in the separate bus mode, port 9 pins can be used as port pins or other alternate-function pins.

(4) Port 9 function control register (PFC9)

**Caution** Port 9 pins cannot be used as port pins or other alternate-function pins if even one of the A0 to A15 pins is used in the separate bus mode. After setting the PFC9 and PFCE9 registers to 0000H, therefore, set all 16 bits of the PMC9 register to FFFFH at once. If none of the A0 to A15 pins is used in the separate bus mode, port 9 pins can be used as port pins or other alternate-function pins.

After reset: 0000H    R/W    Address: PFC9 FFFFF472H,  
PFC9L FFFFF472H, PFC9H FFFFF473H

	15	14	13	12	11	10	9	8
PFC9 (PFC9H)	PFC915	PFC914	PFC913	PFC912	PFC911	PFC910	PFC99	PFC98
	7	6	5	4	3	2	1	0
(PFC9L)	PFC97	PFC96	PFC95	PFC94	PFC93	PFC92	PFC91	PFC90

**Remarks**

1. For details of alternate function specification, see 4.3.10 (6) **Port 9 alternate function specifications**.
2. The PFC9 register can be read or written in 16-bit units.  
However, when using the higher 8 bits of the PFC9 register as the PFC9H register and the lower 8 bits as the PFC9L register, PFC9 can be read or written in 8-bit or 1-bit units.
3. To read/write bits 8 to 15 of the PFC9 register in 8-bit or 1-bit units, specify them as bits 0 to 7 of the PFC9H register.

(5) Port 9 function control expansion register (PFCE9)

After reset: 0000H    R/W    Address: PFCE9 FFFFF712H,  
PFCE9L FFFFF712H, PFCE9H FFFFF713H

	15	14	13	12	11	10	9	8
PFCE9 (PFCE9H)	PFCE915	PFCE914	0	0	0	0	0	0
	7	6	5	4	3	2	1	0
(PFCE9L)	PFCE97	PFCE96	PFCE95	PFCE94	PFCE93	PFCE92	PFCE91	PFCE90

**Remarks**

1. For details of alternate function specification, see 4.3.10 (6) **Port 9 alternate function specifications**.
2. The PFCE9 register can be read or written in 16-bit units.  
However, when using the higher 8 bits of the PFCE9 register as the PFCE9H register and the lower 8 bits as the PFCE9L register, PFCE9 can be read or written in 8-bit or 1-bit units.
3. To read/write bits 8 to 15 of the PFCE9 register in 8-bit or 1-bit units, specify them as bits 0 to 7 of the PFCE9H register.

## (6) Port 9 alternate function specifications

PFCE915	PFC915	Specification of P915 pin alternate function
0	0	A15 output
0	1	INTP6 input
1	0	TIP50 input
1	1	TOP50 output

PFCE914	PFC914	Specification of P914 pin alternate function
0	0	A14 output
0	1	INTP5 input
1	0	TIP51 input
1	1	TOP51 output

PFC913	Specification of P913 pin alternate function
0	A13 output
1	INTP4 input

PFC912	Specification of P912 pin alternate function
0	A12 output
1	SCKB3 I/O

PFC911	Specification of P911 pin alternate function
0	A11 output
1	SOB3 output

PFC910	Specification of P910 pin alternate function
0	A10 output
1	SIB3 input

PFC99	Specification of P99 pin alternate function
0	A9 output
1	SCKB1 I/O

PFC98	Specification of P98 pin alternate function
0	A8 output
1	SOB1 output

PFCE97	PFC97	Specification of P97 pin alternate function
0	0	A7 output
0	1	SIB1 input
1	0	TIP20 input
1	1	TOP20 output

PFCE96	PFC96	Specification of P96 pin alternate function
0	0	A6 output
0	1	Setting prohibited
1	0	TIP21 input
1	1	TOP21 output

PFCE95	PFC95	Specification of P95 pin alternate function
0	0	A5 output
0	1	TIP30 input
1	0	TOP30 output
1	1	INTP5 input

PFCE94	PFC94	Specification of P94 pin alternate function
0	0	A4 output
0	1	TIP31 input
1	0	TOP31 output
1	1	Setting prohibited

PFCE93	PFC93	Specification of P93 pin alternate function
0	0	A3 output
0	1	TIP40 input
1	0	TOP40 output
1	1	INTP8 input

PFCE92	PFC92	Specification of P92 pin alternate function
0	0	A2 output
0	1	TIP41 input
1	0	TOP41 output
1	1	Setting prohibited

PFCE91	PFC91	Specification of P91 pin alternate function
0	0	A1 output
0	1	KR7 input
1	0	RXDA1 input/KR7 input <sup>Note</sup>
1	1	SCL02 I/O

PFCE90	PFC90	Specification of P90 pin alternate function
0	0	A0 output
0	1	KR6 input
1	0	TXDA1 output
1	1	SDA02 I/O

**Note** The RXDA1 and KR7 pins must not be used at the same time. When using the RXDA1 pin, do not use the KR7 pin (clear the KRM.KRM7 bit to 0). When using the KR7 pin, do not use the RXDA1 pin (it is recommended to set the PFC91 bit to 1 and clear the PFCE91 bit to 0). When the PFC91 bit is cleared to 0 and the PFCE91 bit is set to 1, clear the UA1CTL0.UA1RXE bit to 0.

(7) Port 9 function register (PF9)

After reset: 0000H R/W Address: PF3 FFFFFFFC72H,  
PF9L FFFFFFFC72H, PF9H FFFFFFFC73H

	15	14	13	12	11	10	9	8
PF9 (PF9H)	PF915	PF914	PF913	PF912	PF911	PF910	PF99	PF98

	7	6	5	4	3	2	1	0
(PF9L)	PF97	PF96	PF95	PF94	PF93	PF92	PF91	PF90

PF9n	Control of normal output or N-ch open-drain output (n = 0 to 15)
0	Normal output (CMOS output)
1	N-ch open-drain output

**Caution** To pull up an output pin at  $EV_{DD}$  or higher, be sure to set the appropriate PF9n bit to 1.

- Remarks**
1. The PF9 register can be read or written in 16-bit units.  
However, when using the higher 8 bits of the PF9 register as the PF9H register and the lower 8 bits as the PF9L register, PF9 can be read or written in 8-bit or 1-bit units.
  2. To read/write bits 8 to 15 of the PF9 register in 8-bit or 1-bit units, specify them as bits 0 to 7 of the PF9H register.

4.3.11 Port 13 (V850E/SK3-H only)

Port 13 is a 4-bit port for which I/O settings can be controlled in 1-bit units.

Port 13 includes the following alternate-function pins.

Table 4-16. Port 13 Alternate-Function Pins

Pin Name	Pin No.		Alternate-Function Pin Name	I/O	Remark	Block Type
	SJ3-H	SK3-H				
	GJ	GM				
P130	–	125	–	–	–	B-1
P131	–	126	–	–	–	B-1
P132	–	127	–	–	–	B-1
P133	–	128	–	–	–	B-1

**Remark** SJ3-H: V850E/SJ3-H  
 SK3-H: V850E/SK3-H  
 GJ (V850E/SJ3-H): 144-pin plastic LQFP (fine pitch) (20 × 20)  
 GM (V850E/SK3-H): 176-pin plastic LQFP (fine pitch) (24 × 24)

(1) Port 13 register (P13)

After reset: 00H (output latch) R/W Address: FFFFF41AH

	7	6	5	4	3	2	1	0
P13	0	0	0	0	P133	P132	P131	P130

P13n	Output data control (in output mode) (n = 0 to 3)
0	Outputs 0.
1	Outputs 1.

**Caution** Be sure to clear bits 4 to 7 to “0”.

(2) Port 13 mode register (PM13)

After reset: FFH R/W Address: FFFFF43AH

	7	6	5	4	3	2	1	0
PM13	1	1	1	1	PM133	PM132	PM131	PM130

PM13n	I/O mode control (n = 0 to 3)
0	Output mode
1	Input mode

**Caution** Be sure to set bits 4 to 7 to “1”.



**4.3.12 Port 14 (V850E/SK3-H only)**

Port 14 is a 6-bit port for which I/O settings can be controlled in 1-bit units.

Port 14 includes the following alternate-function pins.

**Table 4-17. Port 14 Alternate-Function Pins**

Pin Name	Pin No.		Alternate-Function Pin Name	I/O	Remark	Block Type
	SJ3-H	SK3-H				
	GJ	GM				
P140	–	155	–	–	–	B-1
P141	–	156	–	–	–	B-1
P142	–	157	–	–	–	B-1
P143	–	158	–	–	–	B-1
P144	–	159	–	–	–	B-1
P145	–	160	–	–	–	B-1

**Remark** SJ3-H: V850E/SJ3-H

SK3-H: V850E/SK3-H

GJ (V850E/SJ3-H): 144-pin plastic LQFP (fine pitch) (20 × 20)

GM (V850E/SK3-H): 176-pin plastic LQFP (fine pitch) (24 × 24)

**(1) Port 14 register (P14)**

After reset: 00H (output latch) R/W Address: FFFFF41CH

	7	6	5	4	3	2	1	0
P14	0	0	P145	P144	P143	P142	P141	P140

P14n	Output data control (in output mode) (n = 0 to 5)
0	Outputs 0.
1	Outputs 1.

**Caution** Be sure to clear bits 6 and 7 to “0”.

**(2) Port 14 mode register (PM14)**

After reset: FFH R/W Address: FFFFF43CH

	7	6	5	4	3	2	1	0
PM14	1	1	PM145	PM144	PM143	PM142	PM141	PM140

PM14n	I/O mode control (n = 0 to 5)
0	Output mode
1	Input mode

**Caution** Be sure to set bits 6 and 7 to “1”.

4.3.13 Port 15 (V850E/SK3-H only)

Port 15 is a 6-bit port for which I/O settings can be controlled in 1-bit units.

Port 15 includes the following alternate-function pins.

Table 4-18. Port 15 Alternate-Function Pins

Pin Name	Pin No.		Alternate-Function Pin Name	I/O	Remark	Block Type
	SJ3-H	SK3-H				
	GJ	GM				
P150	–	93	RXDA1/KR7	Input	N-ch open-drain output selectable	E-4
P151	–	94	TXDA1	Output		E-2
P152	–	95	INTP9	Input		L-1
P153	–	96	INTP6	Input		L-1

**Caution** The P150, P152, and P153 pins have hysteresis characteristics in the input mode of the alternate-function pin, but do not have the hysteresis characteristics in the port mode.

**Remark** SJ3-H: V850E/SJ3-H  
 SK3-H: V850E/SK3-H  
 GJ (V850E/SJ3-H): 144-pin plastic LQFP (fine pitch) (20 × 20)  
 GM (V850E/SK3-H): 176-pin plastic LQFP (fine pitch) (24 × 24)

(1) Port 15 register (P15)

After reset: 00H (output latch) R/W Address: FFFFF41EH

	7	6	5	4	3	2	1	0
P15	0	0	0	0	P153	P152	P151	P150

P15n	Output data control (in output mode) (n = 0 to 3)
0	Outputs 0.
1	Outputs 1.

**Caution** Be sure to clear bits 4 to 7 to “0”.

(2) Port 15 mode register (PM15)

After reset: FFH R/W Address: FFFFF43EH

	7	6	5	4	3	2	1	0
PM15	1	1	1	1	PM153	PM152	PM151	PM150

PM15n	I/O mode control (n = 0 to 3)
0	Output mode
1	Input mode

**Caution** Be sure to set bits 4 to 7 to “1”.

**(3) Port 15 mode control register (PMC15)**

After reset: 00H    R/W    Address: FFFFF45EH

	7	6	5	4	3	2	1	0
PMC15	0	0	0	0	PMC153	PMC152	PMC151	PMC150

PMC153	Specification of P153 pin operation mode
0	I/O port
1	INTP6 input

PMC152	Specification of P152 pin operation mode
0	I/O port
1	INTP9 input

PMC151	Specification of P151 pin operation mode
0	I/O port
1	TXDA1 output

PMC150	Specification of P150 pin operation mode
0	I/O port
1	RXDA1 input/KR7 input <sup>Note</sup>

**Note** The RXDA1 and KR7 pins must not be used at the same time. When using the RXDA1 pin, do not use the KR7 pin (clear the KRM.KRM7 bit to 0). When using the KR7 pin, do not use the RXDA1 pin (clear the UA1CTL0.UA1RXE bit to 0).

**Caution** Be sure to clear bits 4 to 7 to “0”.

**(4) Port 15 function register (PF15)**

After reset: 00H    R/W    Address: FFFFFC7EH

	7	6	5	4	3	2	1	0
PF15	0	0	0	0	PF153	PF152	PF151	PF150

PF15n	Control of normal output or N-ch open-drain output (n = 0 to 3)
0	Normal output (CMOS output)
1	N-ch open-drain output

**Cautions**

1. To pull up an output pin at  $EV_{DD}$  or higher, be sure to set the appropriate PF15n bit to 1.
2. Be sure to clear bits 4 to 7 to “0”.

4.3.14 Port CD

Port CD is a 4-bit port for which I/O settings can be controlled in 1-bit units.

Port CD includes the following alternate-function pins.

Table 4-19. Port CD Alternate-Function Pins

Pin Name	Pin No.		Alternate-Function Pin Name	I/O	Remark	Block Type
	SJ3-H	SK3-H				
	GJ	GM				
PCD0	77	97	RXDB0	Input	-	F-1
PCD1	78	98	TXDB0	Output		F-2
PCD2	79	99	RXDB1	Input		F-1
PCD3	80	100	TXDB1	Output		F-2

**Caution** The PCD0 and PCD2 pins have hysteresis characteristics in the input mode of the alternate-function pin, but do not have the hysteresis characteristics in the port mode.

**Remark** SJ3-H: V850E/SJ3-H  
 SK3-H: V850E/SK3-H  
 GJ (V850E/SJ3-H): 144-pin plastic LQFP (fine pitch) (20 × 20)  
 GM (V850E/SK3-H): 176-pin plastic LQFP (fine pitch) (24 × 24)

(1) Port CD register (PCD)

After reset: 00H (output latch) R/W Address: FFFF00EH

	7	6	5	4	3	2	1	0
PCD	0	0	0	0	PCD3	PCD2	PCD1	PCD0

PCDn	Output data control (in output mode) (n = 0 to 3)
0	Outputs 0.
1	Outputs 1.

**Caution** Be sure to clear bits 4 to 7 to “0”.

(2) Port CD mode register (PMCD)

After reset: FFH R/W Address: FFFF02EH

	7	6	5	4	3	2	1	0
PMCD	1	1	1	1	PMCD3	PMCD2	PMCD1	PMCD0

PMCDn	I/O mode control (n = 0 to 3)
0	Output mode
1	Input mode

**Caution** Be sure to set bits 4 to 7 to “1”.

**(3) Port CD mode control register (PMCCD)**

After reset: 00H    R/W    Address: FFFF04EH

	7	6	5	4	3	2	1	0
PMCCD	0	0	0	0	PMCCD3	PMCCD2	PMCCD1	PMCCD0

PMCCD3	Specification of PCD3 pin operation mode
0	I/O port
1	TXDB1 output

PMCCD2	Specification of PCD2 pin operation mode
0	I/O port
1	RXDB1 input

PMCCD1	Specification of PCD1 pin operation mode
0	I/O port
1	TXDB0 output

PMCCD0	Specification of PCD0 pin operation mode
0	I/O port
1	RXDB0 input

**Caution** Be sure to clear bits 4 to 7 to “0”.

**(4) Port CD function control register (PFCCD)**

After reset: 00H    R/W    Address: FFFF04FH

	7	6	5	4	3	2	1	0
PFCCD	0	0	0	0	PFCCD3	PFCCD2	PFCCD1	PFCCD0

PFCCD3	Specification of PCD3 pin alternate function
0	Setting prohibited
1	TXDB1 input

PFCCD2	Specification of PCD2 pin alternate function
0	Setting prohibited
1	RXDB1 input

PFCCD1	Specification of PCD1 pin alternate function
0	Setting prohibited
1	TXDB0 output

PFCCD0	Specification of PCD0 pin alternate function
0	Setting prohibited
1	RXDB0 input

**Caution** Be sure to clear bits 4 to 7 to “0”.

4.3.15 Port CM

Port CM is a 6-bit port for which I/O settings can be controlled in 1-bit units.

Port CM includes the following alternate-function pins.

Table 4-20. Port CM Alternate-Function Pins

Pin Name	Pin No.		Alternate-Function Pin Name	I/O	Remark	Block Type
	SJ3-H	SK3-H				
	GJ	GM				
PCM0	85	105	WAIT	Input	–	D-1
PCM1	86	106	CLKOUT	Output		D-2
PCM2	87	107	HLD $\overline{\text{AK}}$	Output		D-2
PCM3	88	108	HLD $\overline{\text{RQ}}$	Input		D-1
PCM4	89	109	–	–		B-1
PCM5	90	110	–	–		B-1

**Remark** SJ3-H: V850E/SJ3-H  
 SK3-H: V850E/SK3-H  
 GJ (V850E/SJ3-H): 144-pin plastic LQFP (fine pitch) (20 × 20)  
 GM (V850E/SK3-H): 176-pin plastic LQFP (fine pitch) (24 × 24)

(1) Port CM register (PCM)

After reset: 00H (output latch) R/W Address: FFFFF00CH

	7	6	5	4	3	2	1	0
PCM	0	0	PCM5	PCM4	PCM3	PCM2	PCM1	PCM0

PCMn	Output data control (in output mode) (n = 0 to 5)
0	Outputs 0.
1	Outputs 1.

(2) Port CM mode register (PMCM)

After reset: FFH R/W Address: FFFFF02CH

	7	6	5	4	3	2	1	0
PMCM	1	1	PMCM5	PMCM4	PMCM3	PMCM2	PMCM1	PMCM0

PMCMn	I/O mode control (n = 0 to 5)
0	Output mode
1	Input mode

(3) Port CM mode control register (PMCCM)

After reset: 00H    R/W    Address: FFFFF04CH

	7	6	5	4	3	2	1	0
PMCCM	0	0	0	0	PMCCM3	PMCCM2	PMCCM1	PMCCM0

PMCCM3		Specification of PCM3 pin operation mode
0		I/O port
1		$\overline{\text{HLDRQ}}$ input

PMCCM2		Specification of PCM2 pin operation mode
0		I/O port
1		$\overline{\text{HLDAK}}$ output

PMCCM1		Specification of PCM1 pin operation mode
0		I/O port
1		CLKOUT output

PMCCM0		Specification of PCM0 pin operation mode
0		I/O port
1		$\overline{\text{WAIT}}$ input

4.3.16 Port CS

Port CS is an 8-bit port for which I/O settings can be controlled in 1-bit units.

Port CS includes the following alternate-function pins.

Table 4-21. Port CS Alternate-Function Pins

Pin Name	Pin No.		Alternate-Function Pin Name	I/O	Remark	Block Type
	SJ3-H	SK3-H				
	GJ	GM				
PCS0	81	101	–	–	–	B-1
PCS1	82	102	$\overline{CS1}$	Output		D-2
PCS2	83	103	$\overline{CS2}$	Output		D-2
PCS3	84	104	$\overline{CS3}$	Output		D-2
PCS4	91	111	–	–		B-1
PCS5	92	112	–	–		B-1
PCS6	93	113	–	–		B-1
PCS7	94	114	–	–		B-1

**Remark** SJ3-H: V850E/SJ3-H  
 SK3-H: V850E/SK3-H  
 GJ (V850E/SJ3-H): 144-pin plastic LQFP (fine pitch) (20 × 20)  
 GM (V850E/SK3-H): 176-pin plastic LQFP (fine pitch) (24 × 24)

(1) Port CS register (PCS)

After reset: 00H (output latch) R/W Address: FFFFF008H

	7	6	5	4	3	2	1	0
PCS	PCS7	PCS6	PCS5	PCS4	PCS3	PCS2	PCS1	PCS0

PCS <sub>n</sub>	Output data control (in output mode) (n = 0 to 7)
0	Outputs 0.
1	Outputs 1.

(2) Port CS mode register (PMCS)

After reset: FFH R/W Address: FFFFF028H

	7	6	5	4	3	2	1	0
PMCS	PMCS7	PMCS6	PMCS5	PMCS4	PMCS3	PMCS2	PMCS1	PMCS0

PMCS <sub>n</sub>	I/O mode control (n = 0 to 7)
0	Output mode
1	Input mode



(3) Port CS mode control register (PMCCS)

After reset: 00H R/W Address: FFFF048H

	7	6	5	4	3	2	1	0
PMCCS	0	0	0	0	PMCCS3	PMCCS2	PMCCS1	0

PMCCS3	Specification of PCS3 pin operation mode
0	I/O port
1	$\overline{CS3}$ output

PMCCS2	Specification of PCS2 pin operation mode
0	I/O port
1	$\overline{CS2}$ output

PMCCS1	Specification of PCS1 pin operation mode
0	I/O port
1	$\overline{CS1}$ output

**Caution** Be sure to clear bits 0 and 4 to 7 to "0".

4.3.17 Port CT

Port CT is an 8-bit port for which I/O settings can be controlled in 1-bit units.

Port CT includes the following alternate-function pins.

Table 4-22. Port CT Alternate-Function Pins

Pin Name	Pin No.		Alternate-Function Pin Name	I/O	Remark	Block Type
	SJ3-H	SK3-H				
	GJ	GM				
PCT0	95	115	$\overline{WR0}$	Output	-	D-2
PCT1	96	116	$\overline{WR1}$	Output		D-2
PCT2	97	117	-	-		B-1
PCT3	98	118	-	-		B-1
PCT4	99	119	$\overline{RD}$	Output		D-2
PCT5	100	120	-	-		B-1
PCT6	101	121	ASTB	Output		D-2
PCT7	102	122	-	-		B-1

**Remark** SJ3-H: V850E/SJ3-H  
 SK3-H: V850E/SK3-H  
 GJ (V850E/SJ3-H): 144-pin plastic LQFP (fine pitch) (20 × 20)  
 GM (V850E/SK3-H): 176-pin plastic LQFP (fine pitch) (24 × 24)

(1) Port CT register (PCT)

After reset: 00H (output latch) R/W Address: FFFF00AH

	7	6	5	4	3	2	1	0
PCT	PCT7	PCT6	PCT5	PCT4	PCT3	PCT2	PCT1	PCT0

PCTn	Output data control (in output mode) (n = 0 to 7)
0	Outputs 0.
1	Outputs 1.

(2) Port CT mode register (PMCT)

After reset: FFH R/W Address: FFFF02AH

	7	6	5	4	3	2	1	0
PMCT	PMCT7	PMCT6	PMCT5	PMCT4	PMCT3	PMCT2	PMCT1	PMCT0

PMCTn	I/O mode control (n = 0 to 7)
0	Output mode
1	Input mode

(3) Port CT mode control register (PMCCT)

After reset: 00H    R/W    Address: FFFFF04AH

	7	6	5	4	3	2	1	0
PMCCT	0	PMCCT6	0	PMCCT4	0	0	PMCCT1	PMCCT0

PMCCT6	Specification of PCT6 pin operation mode
0	I/O port
1	ASTB output

PMCCT4	Specification of PCT4 pin operation mode
0	I/O port
1	$\overline{RD}$ output

PMCCT1	Specification of PCT1 pin operation mode
0	I/O port
1	$\overline{WR1}$ output

PMCCT0	Specification of PCT0 pin operation mode
0	I/O port
1	$\overline{WR0}$ output

4.3.18 Port DH

Port DH is an 8-bit port for which I/O settings can be controlled in 1-bit units.

Port DH includes the following alternate-function pins.

Table 4-23. Port DH Alternate-Function Pins

Pin Name	Pin No.		Alternate-Function Pin Name	I/O	Remark	Block Type
	SJ3-H	SK3-H				
	GJ	GM				
PDH0	121	145	A16	Output	-	D-2
PDH1	122	146	A17	Output		D-2
PDH2	123	147	A18	Output		D-2
PDH3	124	148	A19	Output		D-2
PDH4	125	149	A20	Output		D-2
PDH5	126	150	A21	Output		D-2
PDH6	127	151	A22	Output		D-2
PDH7	128	152	A23	Output		D-2

**Remark** SJ3-H: V850E/SJ3-H  
 SK3-H: V850E/SK3-H  
 GJ (V850E/SJ3-H): 144-pin plastic LQFP (fine pitch) (20 × 20)  
 GM (V850E/SK3-H): 176-pin plastic LQFP (fine pitch) (24 × 24)

(1) Port DH register (PDH)

After reset: 00H (output latch)		R/W	Address: FFFFF006H					
	7	6	5	4	3	2	1	0
PDH	PDH7	PDH6	PDH5	PDH4	PDH3	PDH2	PDH1	PDH0
PDHn	Output data control (in output mode) (n = 0 to 7)							
0	Outputs 0.							
1	Outputs 1.							

(2) Port DH mode register (PMDH)

After reset: FFH		R/W	Address: FFFFF026H					
	7	6	5	4	3	2	1	0
PMDH	PMDH7	PMDH6	PMDH5	PMDH4	PMDH3	PMDH2	PMDH1	PMDH0
PMDHn	I/O mode control (n = 0 to 7)							
0	Output mode							
1	Input mode							

(3) Port DH mode control register (PMCDH)

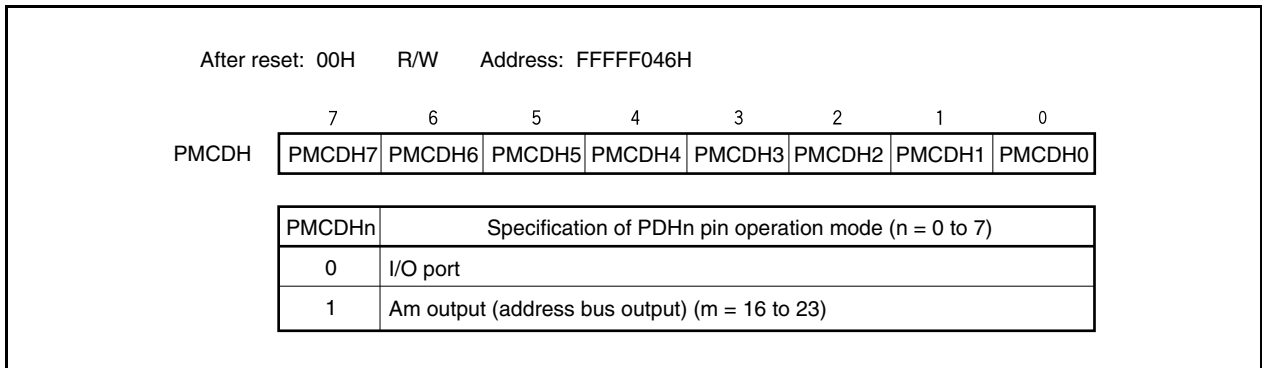

### 4.3.19 Port DL

Port DL is a 16-bit port for which I/O settings can be controlled in 1-bit units.

Port DL includes the following alternate-function pins.

**Table 4-24. Port DL Alternate-Function Pins**

Pin Name	Pin No.		Alternate-Function Pin Name	I/O	Remark	Block Type
	SJ3-H	SK3-H				
	GJ	GM				
PDL0	105	129	AD0	I/O	—	D-3
PDL1	106	130	AD1	I/O		D-3
PDL2	107	131	AD2	I/O		D-3
PDL3	108	132	AD3	I/O		D-3
PDL4	109	133	AD4	I/O		D-3
PDL5	110	134	AD5/FLMD1 <sup>Note</sup>	I/O		D-3
PDL6	111	135	AD6	I/O		D-3
PDL7	112	136	AD7	I/O		D-3
PDL8	113	137	AD8	I/O		D-3
PDL9	114	138	AD9	I/O		D-3
PDL10	115	139	AD10	I/O		D-3
PDL11	116	140	AD11	I/O		D-3
PDL12	117	141	AD12	I/O		D-3
PDL13	118	142	AD13	I/O		D-3
PDL14	119	143	AD14	I/O		D-3
PDL15	120	144	AD15	I/O		D-3

**Note** Since this pin is set in the flash memory programming mode, it does not need to be manipulated with the port control register. For details, see **CHAPTER 32 FLASH MEMORY**.

**Remark** SJ3-H: V850E/SJ3-H  
 SK3-H: V850E/SK3-H  
 GJ (V850E/SJ3-H): 144-pin plastic LQFP (fine pitch) (20 × 20)  
 GM (V850E/SK3-H): 176-pin plastic LQFP (fine pitch) (24 × 24)

(1) Port DL register (PDL)

After reset: 0000H (output latch) R/W Address: PDL FFFFF004H,  
PDLL FFFFF004H, PDLH FFFFF005H

	15	14	13	12	11	10	9	8
PDL (PDLH)	PDL15	PDL14	PDL13	PDL12	PDL11	PDL10	PDL9	PDL8
	7	6	5	4	3	2	1	0
(PDLL)	PDL7	PDL6	PDL5	PDL4	PDL3	PDL2	PDL1	PDL0

PDLn	Output data control (in output mode) (n = 0 to 15)
0	Outputs 0.
1	Outputs 1.

**Remarks**

1. The PDL register can be read or written in 16-bit units.  
However, when using the higher 8 bits of the PDL register as the PDLH register and the lower 8 bits as the PDLL register, PDL can be read or written in 8-bit or 1-bit units.
2. To read/write bits 8 to 15 of the PDL register in 8-bit or 1-bit units, specify them as bits 0 to 7 of the PDLH register.

(2) Port DL mode register (PMDL)

After reset: FFFFH R/W Address: PMDL FFFFF024H,  
PMDLL FFFFF024H, PMDLH FFFFF025H

	15	14	13	12	11	10	9	8
PMDL (PMDLH)	PMDL15	PMDL14	PMDL13	PMDL12	PMDL11	PMDL10	PMDL9	PMDL8
	7	6	5	4	3	2	1	0
(PMDLL)	PMDL7	PMDL6	PMDL5	PMDL4	PMDL3	PMDL2	PMDL1	PMDL0

PMDLn	I/O mode control (n = 0 to 15)
0	Output mode
1	Input mode

**Remarks**

1. The PMDL register can be read or written in 16-bit units.  
However, when using the higher 8 bits of the PMDL register as the PMDLH register and the lower 8 bits as the PMDLL register, PMDL can be read or written in 8-bit or 1-bit units.
2. To read/write bits 8 to 15 of the PMDL register in 8-bit or 1-bit units, specify them as bits 0 to 7 of the PMDLH register.

(3) Port DL mode control register (PMCDL)

After reset: 0000H R/W Address: PMCDL FFFF044H,  
 PMCDLL FFFF044H, PMCDLH FFFF045H

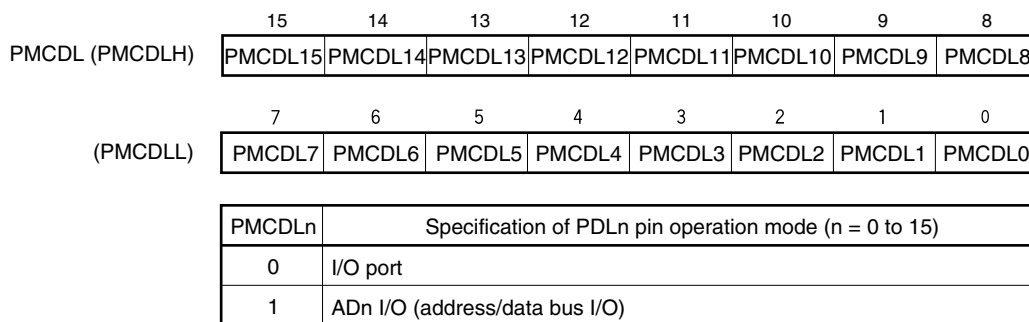

**Caution** When the EXIMC.SMSEL bit = 1 (separate mode) and the BSC.BS30 to BSC.BS00 bits = 0 (8-bit bus width), do not specify the AD8 to AD15 pins.

- Remarks**
1. The PMCDL register can be read or written in 16-bit units.  
 However, when using the higher 8 bits of the PMCDL register as the PMCDLH register and the lower 8 bits as the PMCDLL register, PMCDL can be read or written in 8-bit or 1-bit units.
  2. To read/write bits 8 to 15 of the PMCDL register in 8-bit or 1-bit units, specify them as bits 0 to 7 of the PMCDLH register.



4.4 Block Diagrams

Figure 4-4. Block Diagram of Type A-1

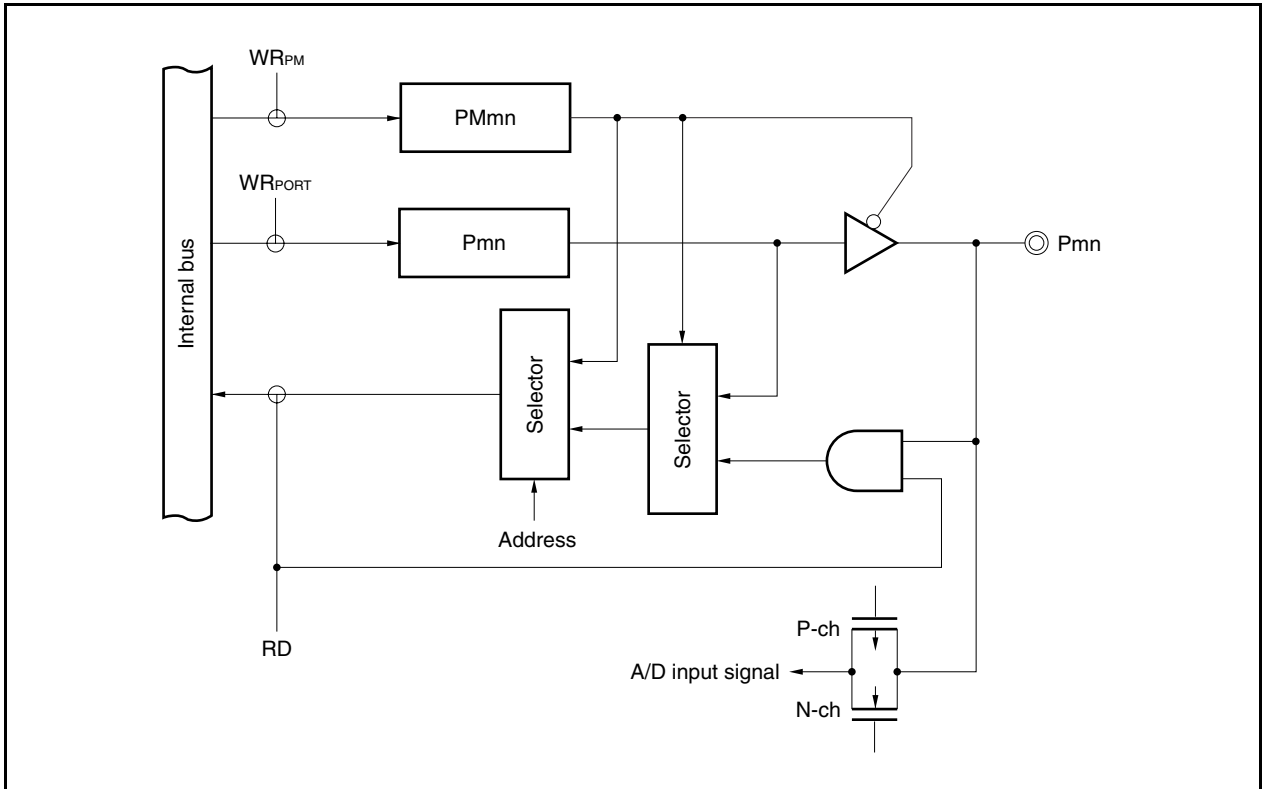

Figure 4-5. Block Diagram of Type A-2

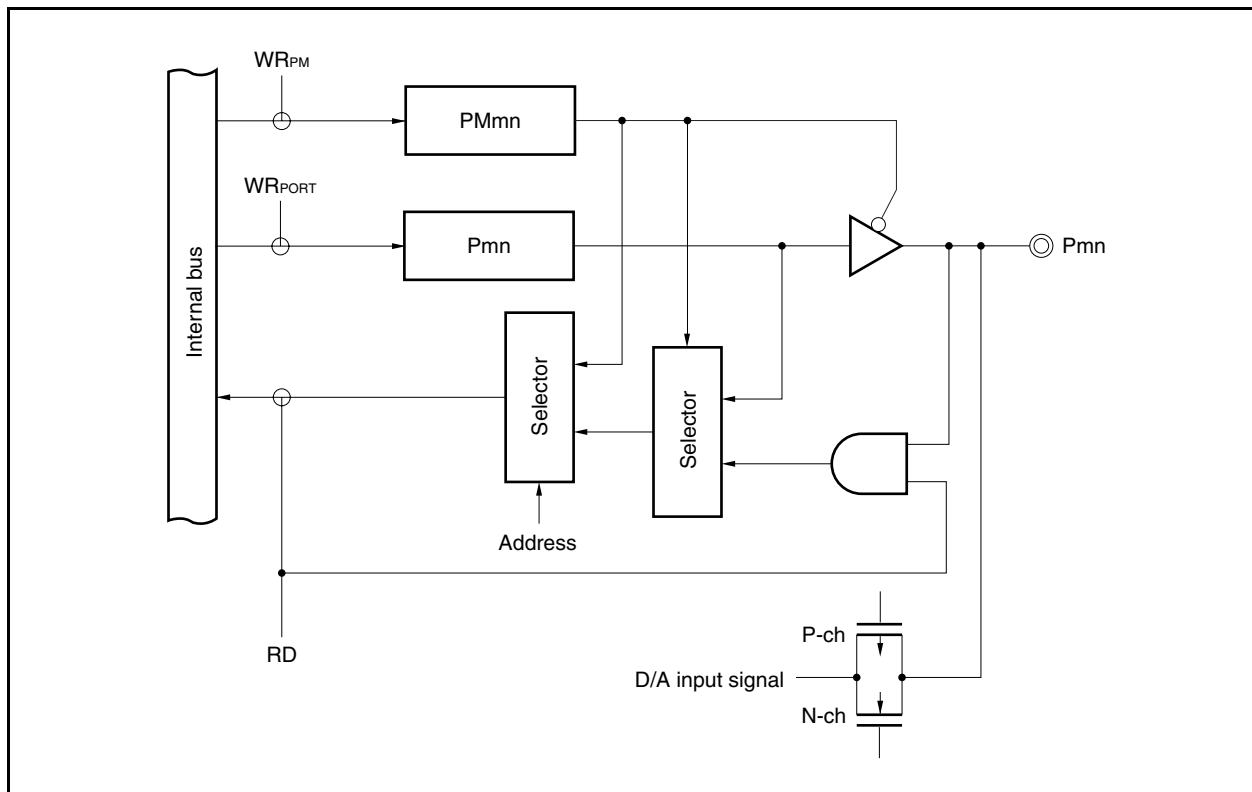

Figure 4-6. Block Diagram of Type B-1

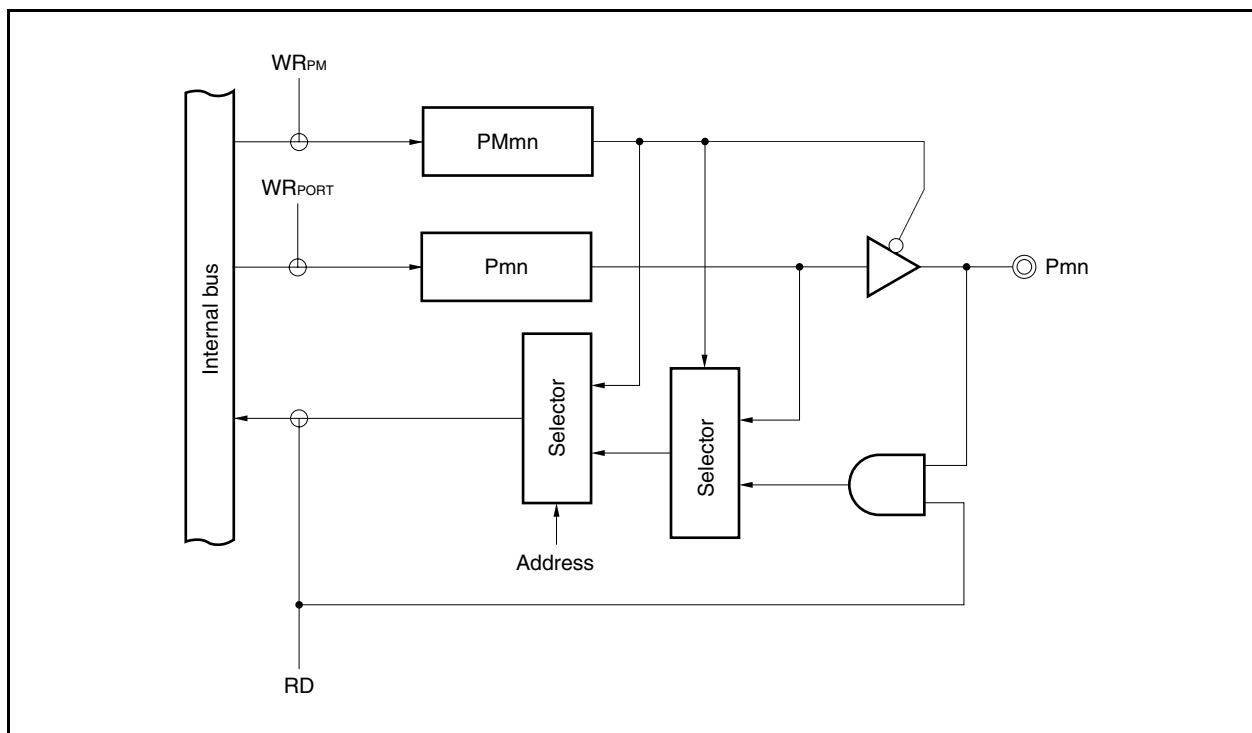

Figure 4-7. Block Diagram of Type C-1

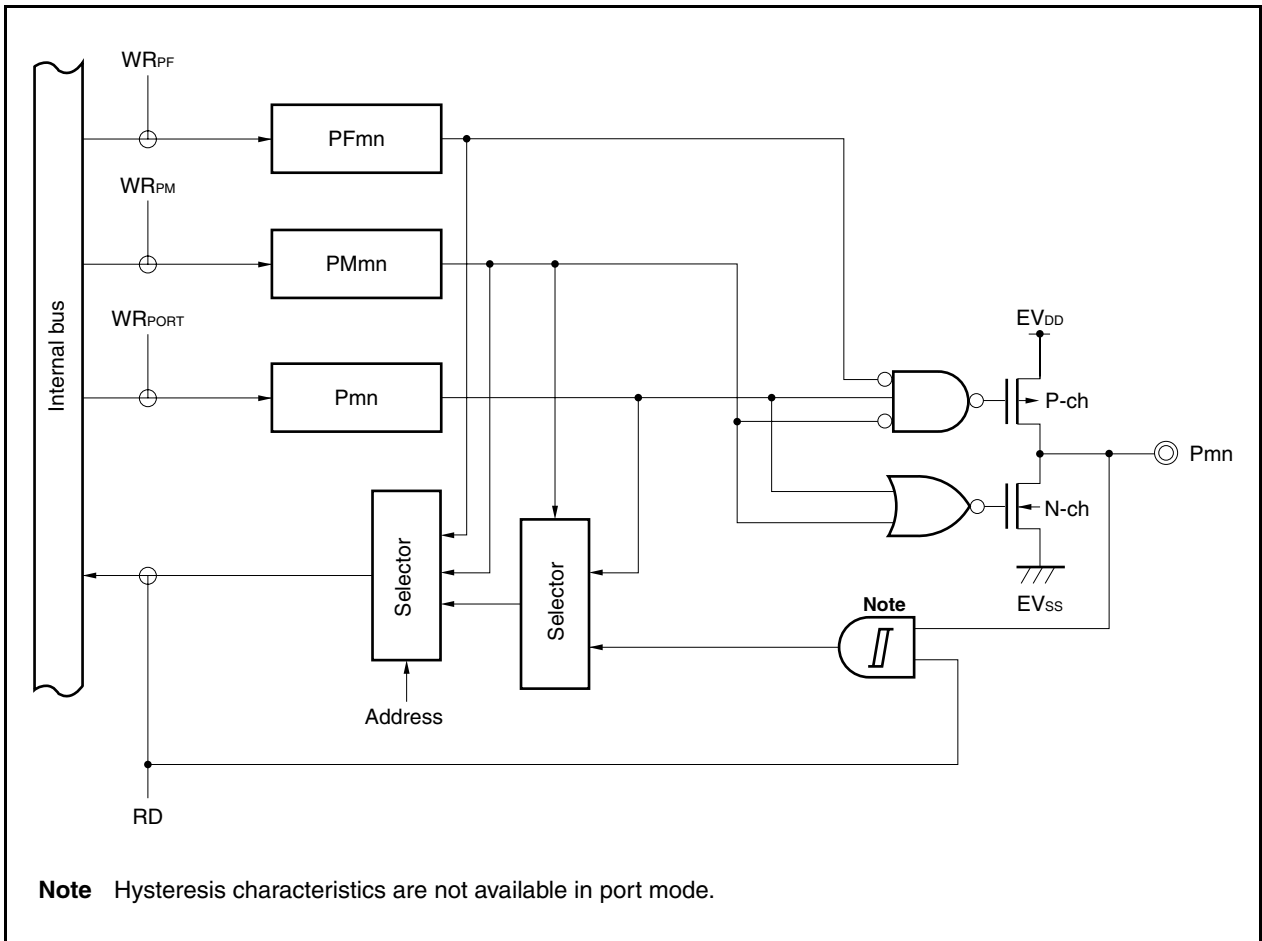

Figure 4-8. Block Diagram of Type D-1

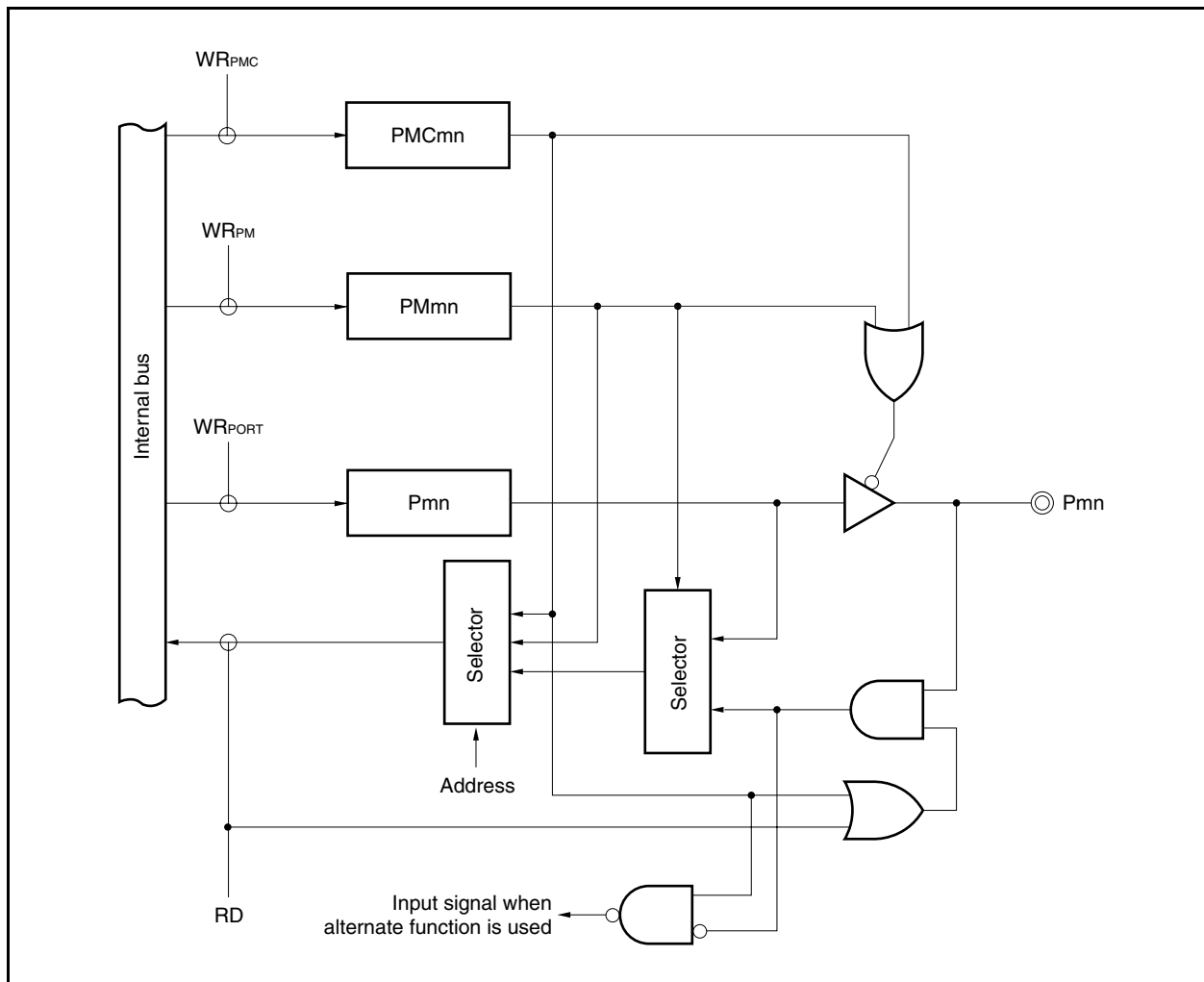

Figure 4-9. Block Diagram of Type D-2

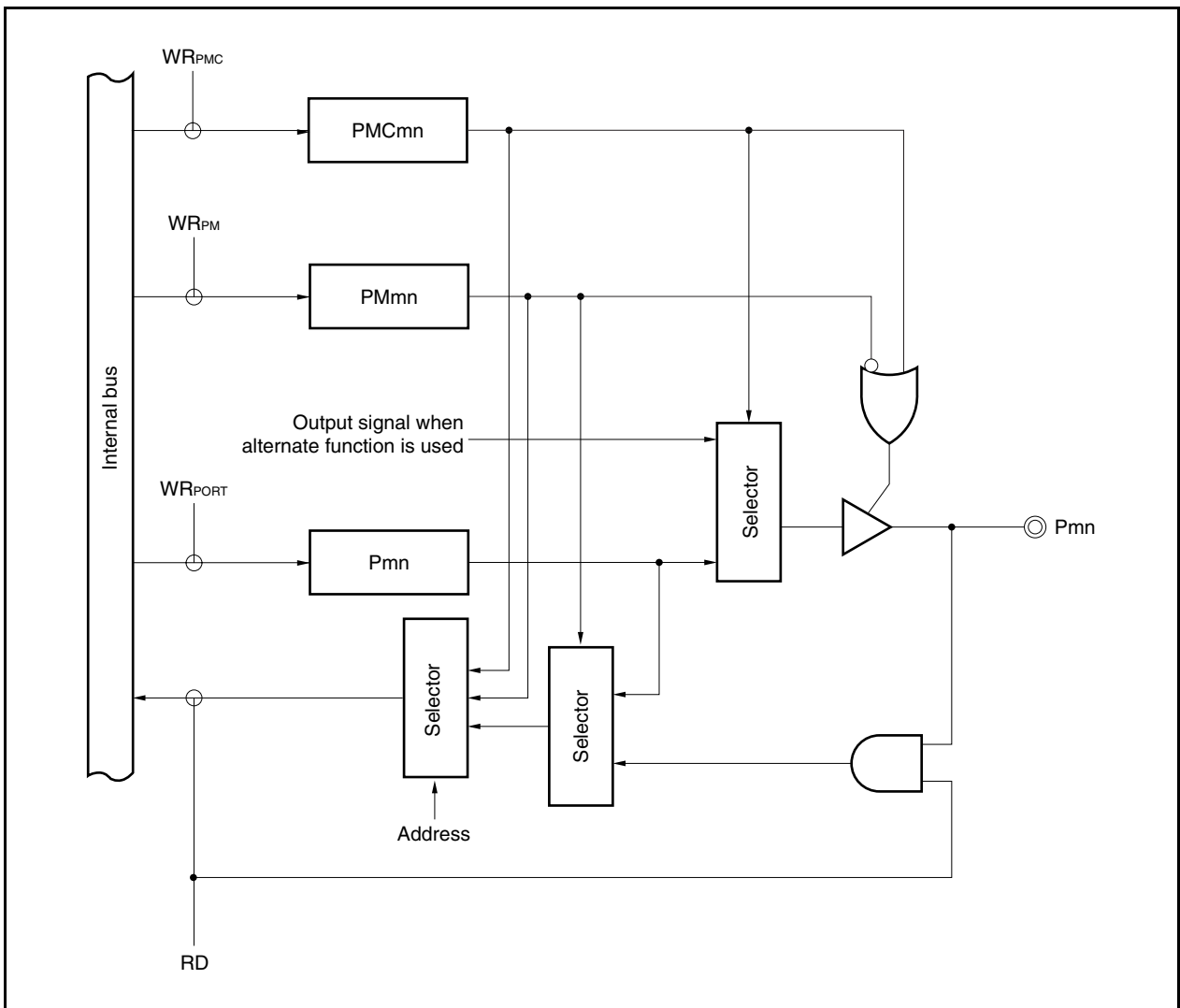

Figure 4-10. Block Diagram of Type D-3

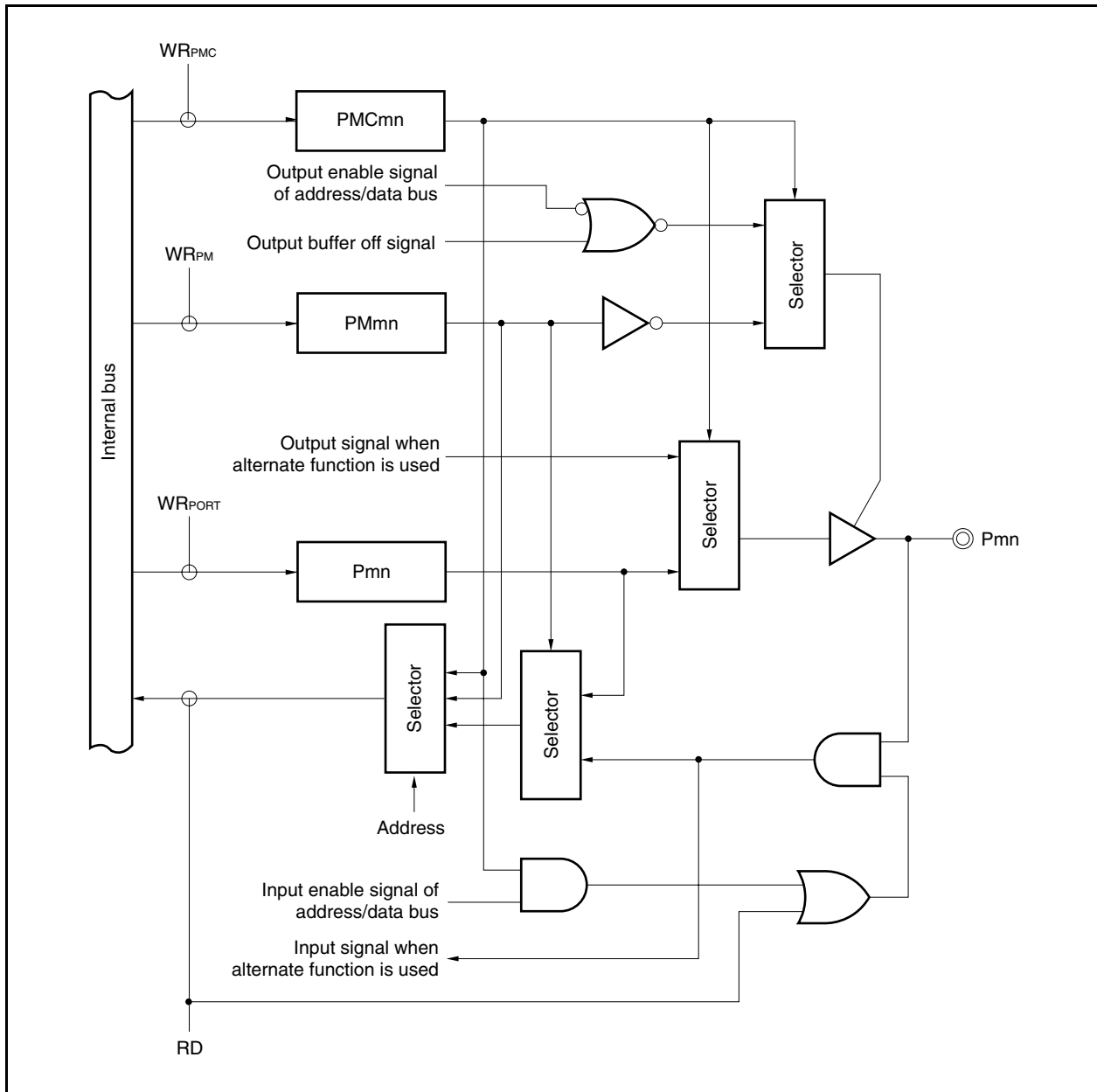

Figure 4-11. Block Diagram of Type E-1

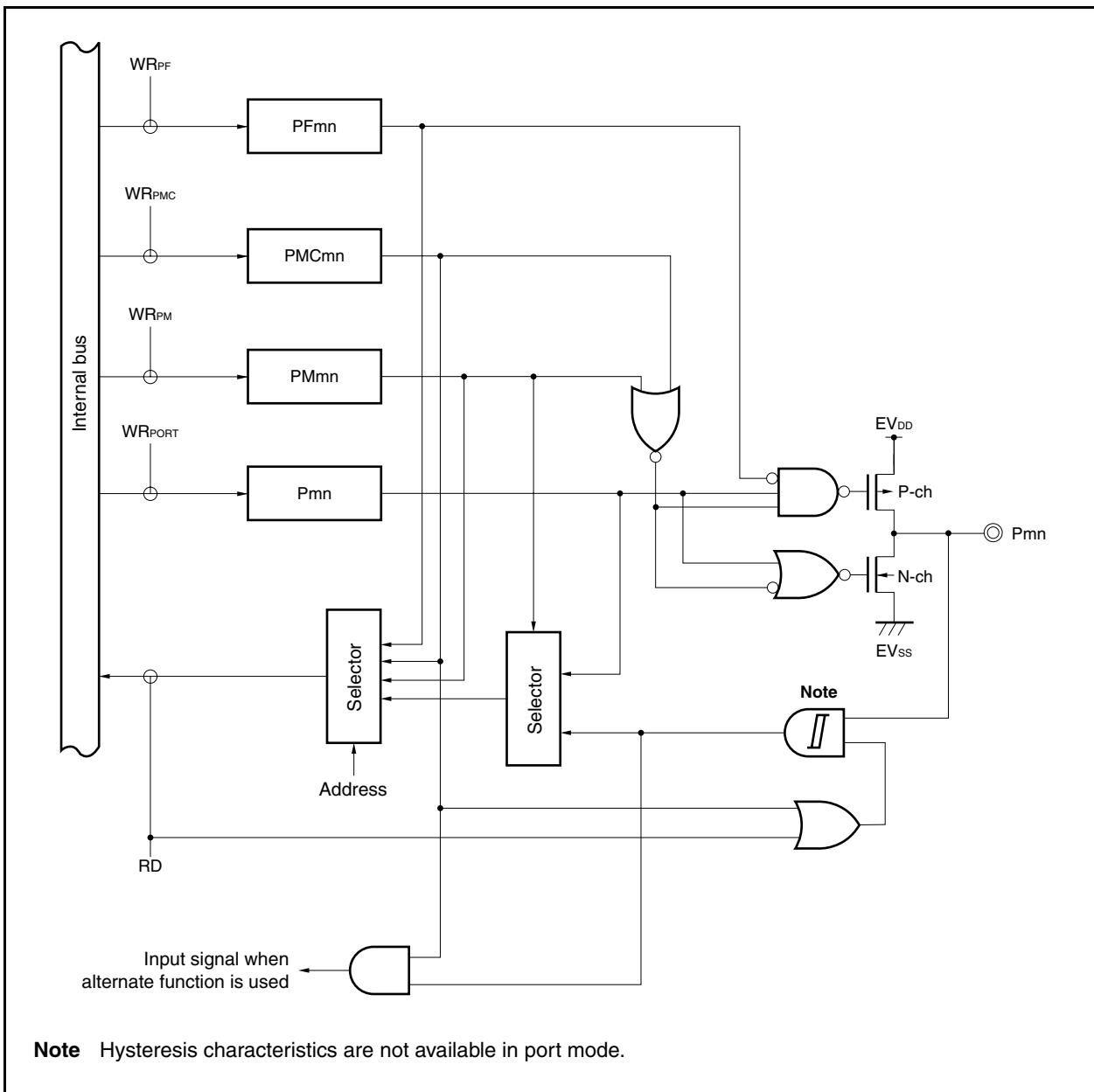

Figure 4-12. Block Diagram of Type E-2

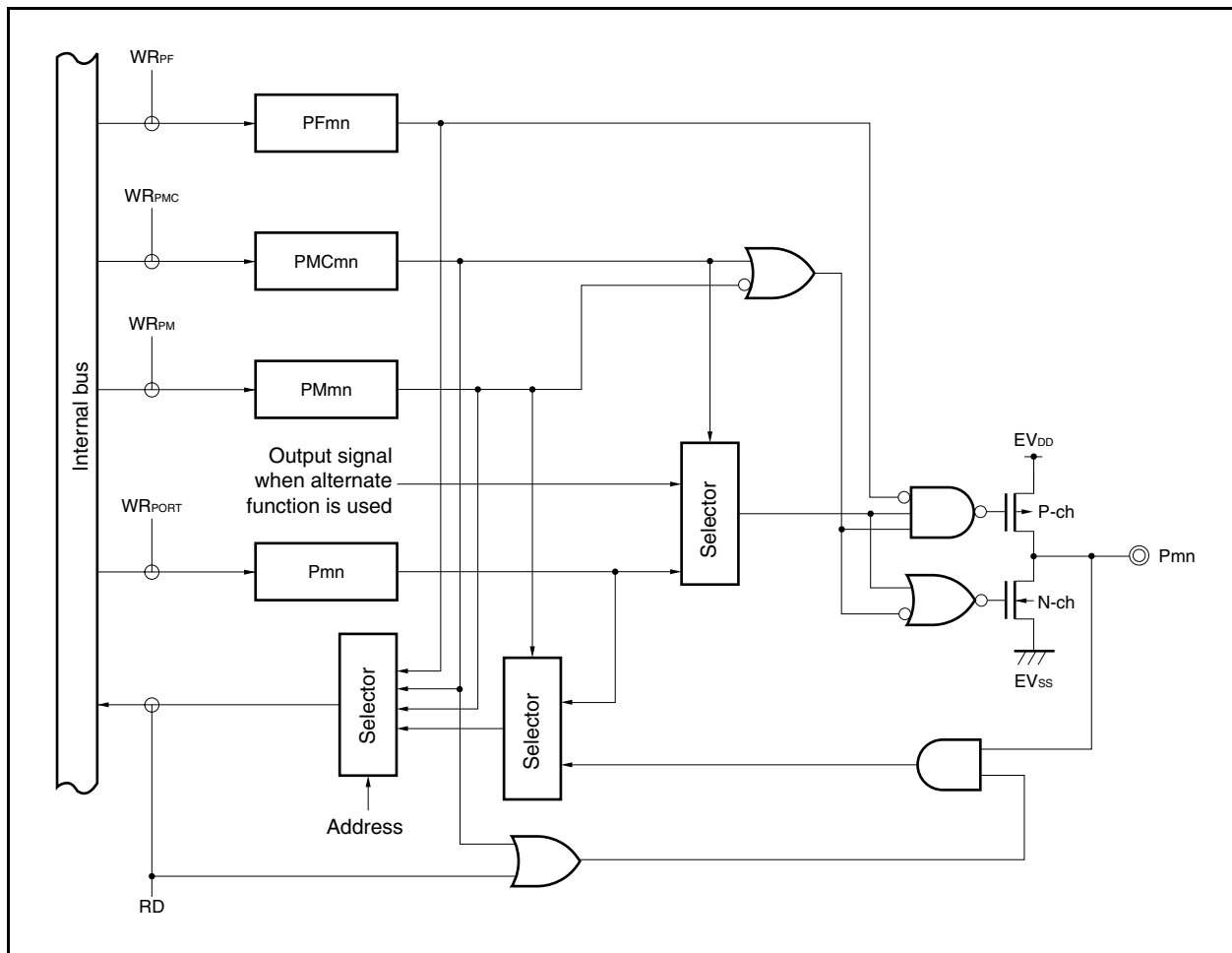



Figure 4-13. Block Diagram of Type E-3

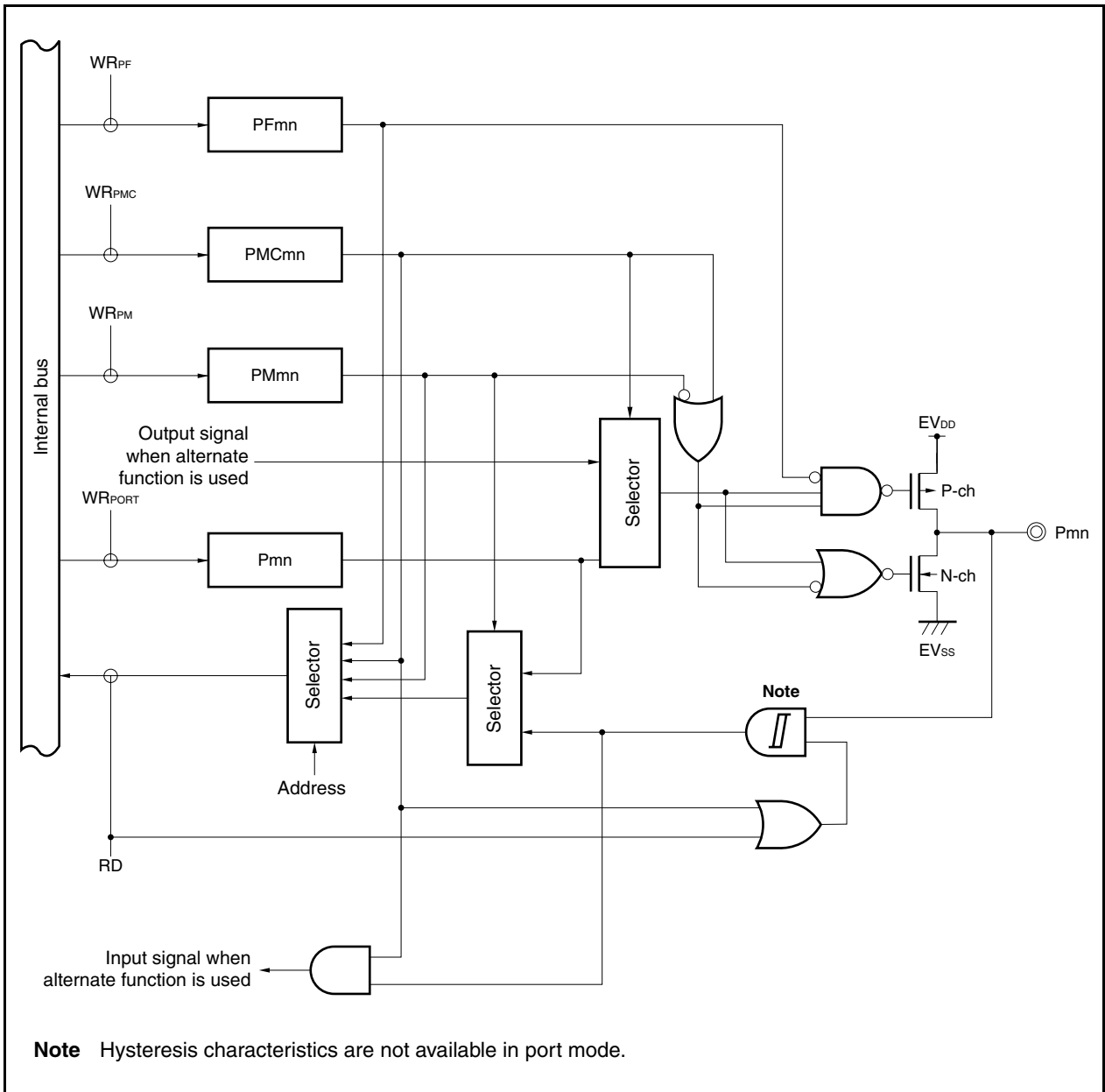

Figure 4-14. Block Diagram of Type E-4

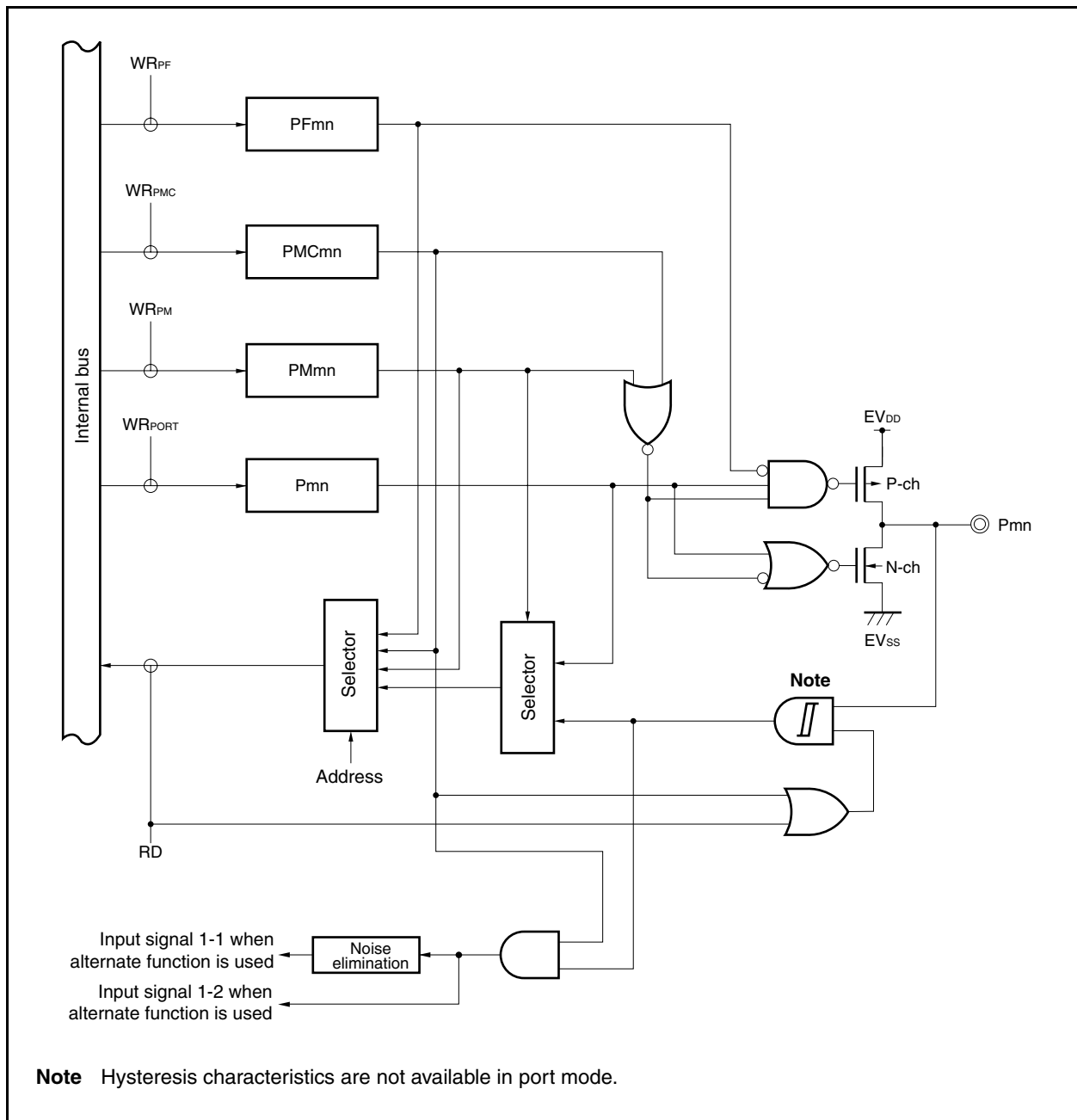

Figure 4-15. Block Diagram of Type F-1

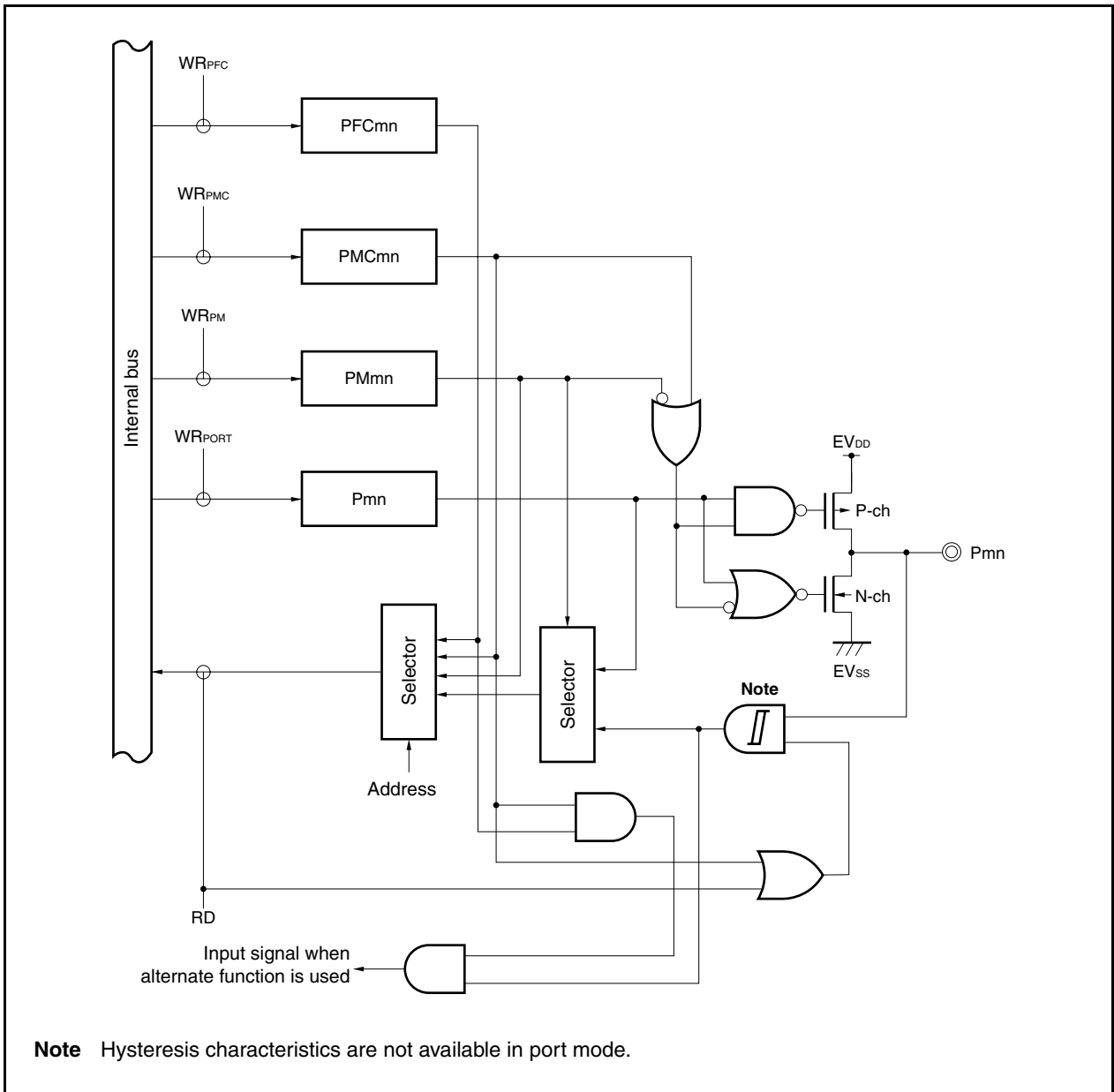

Figure 4-16. Block Diagram of Type F-2

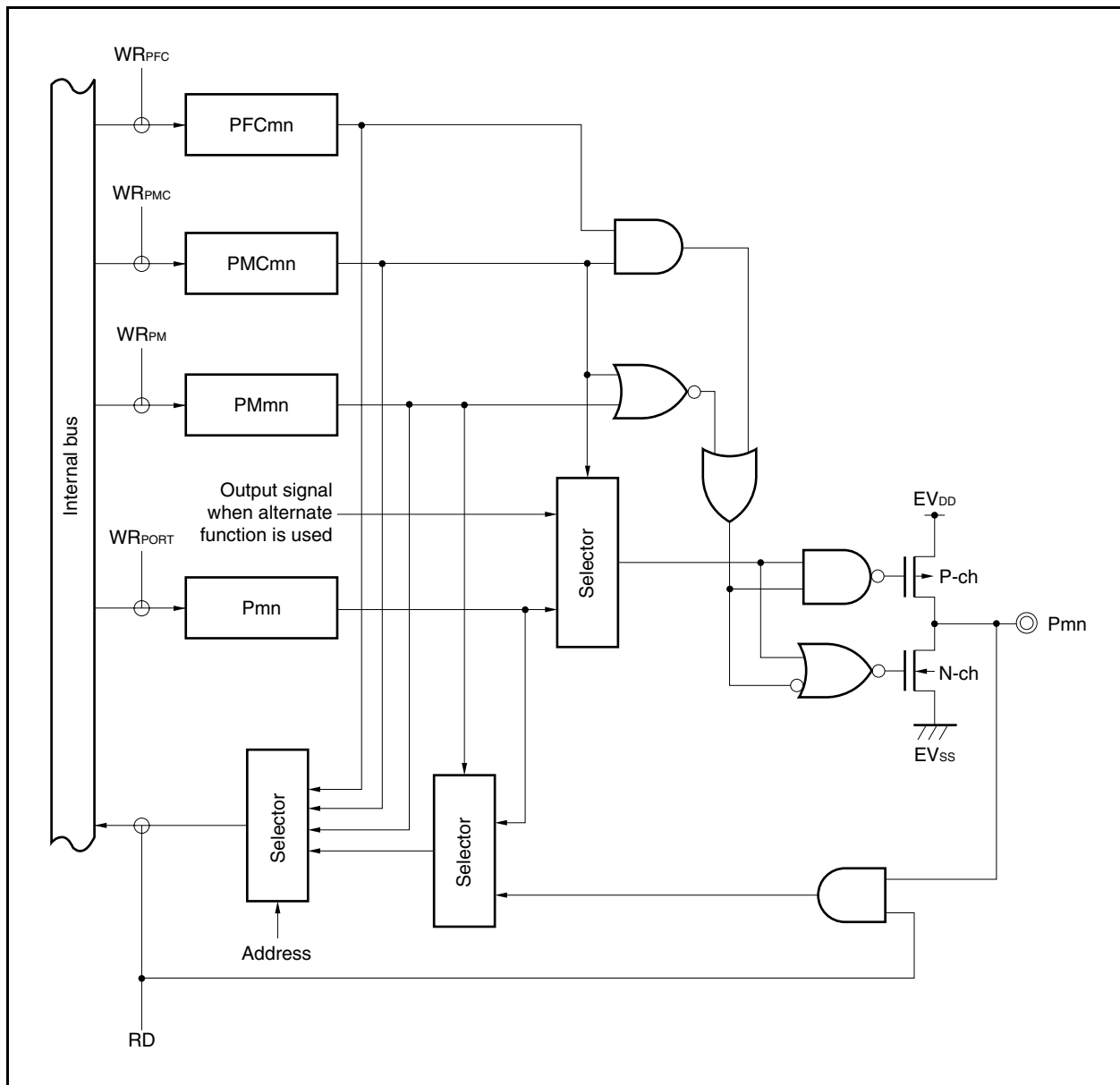

Figure 4-17. Block Diagram of Type G-1

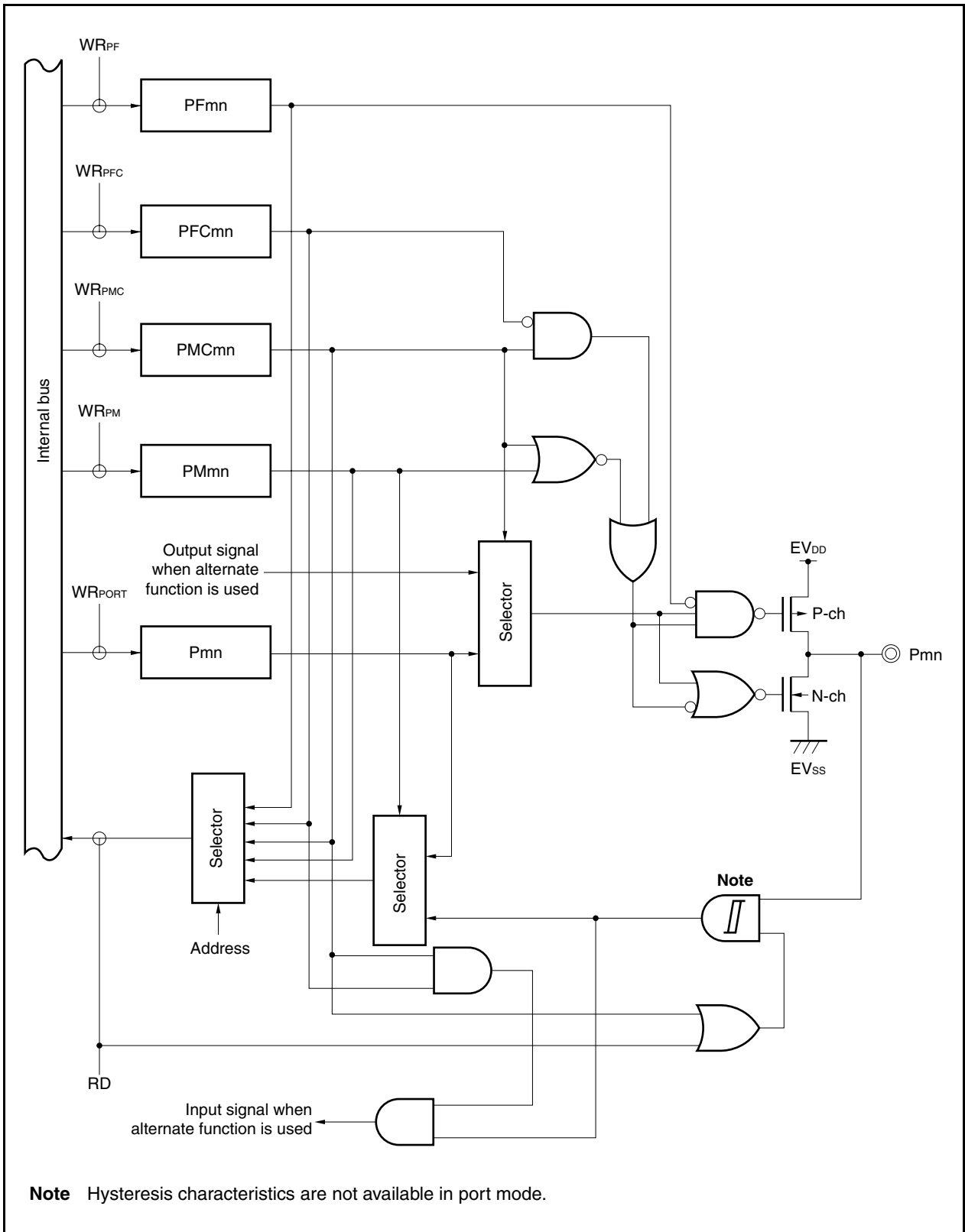

Figure 4-18. Block Diagram of Type G-2

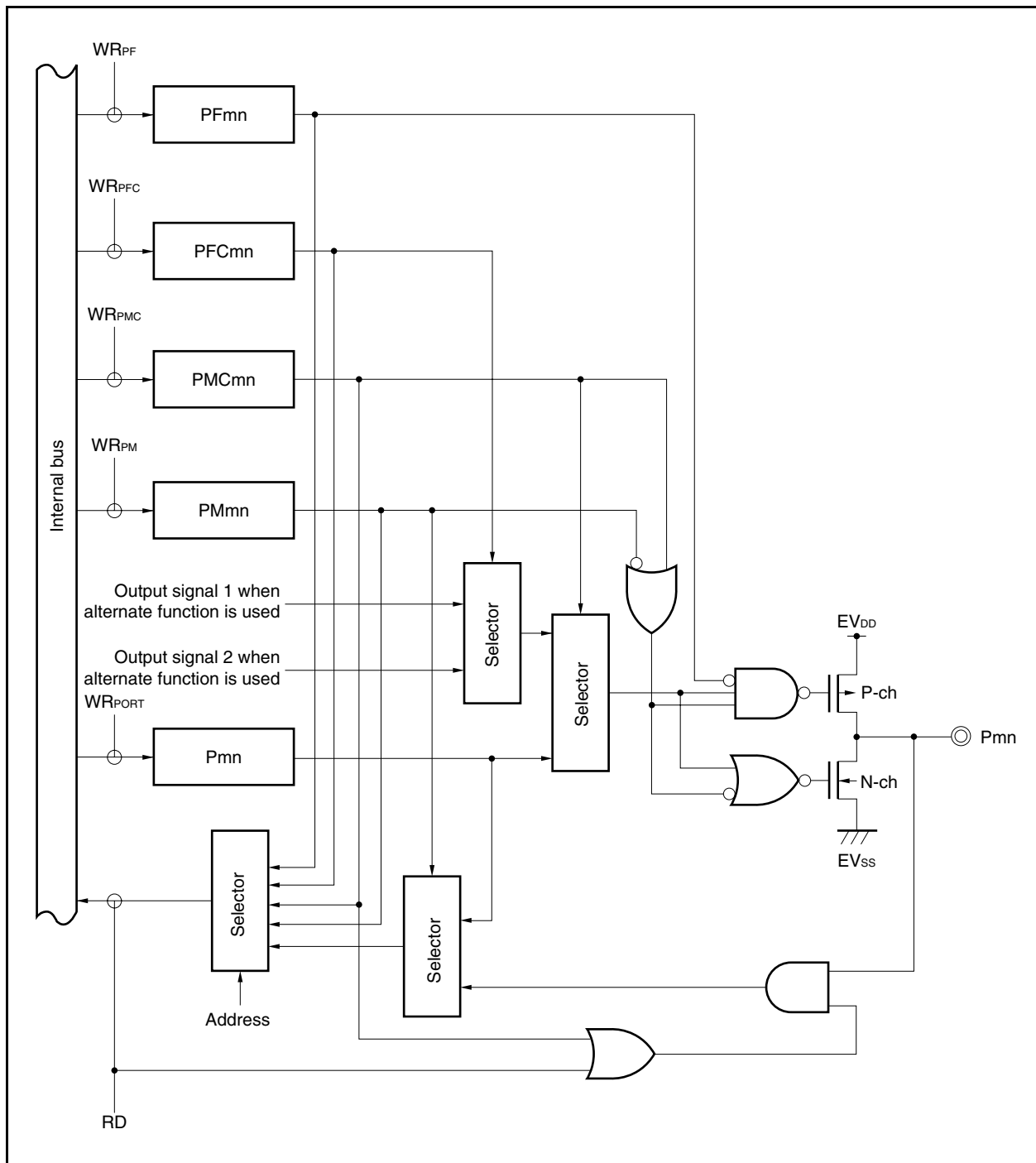

Figure 4-19. Block Diagram of Type G-3

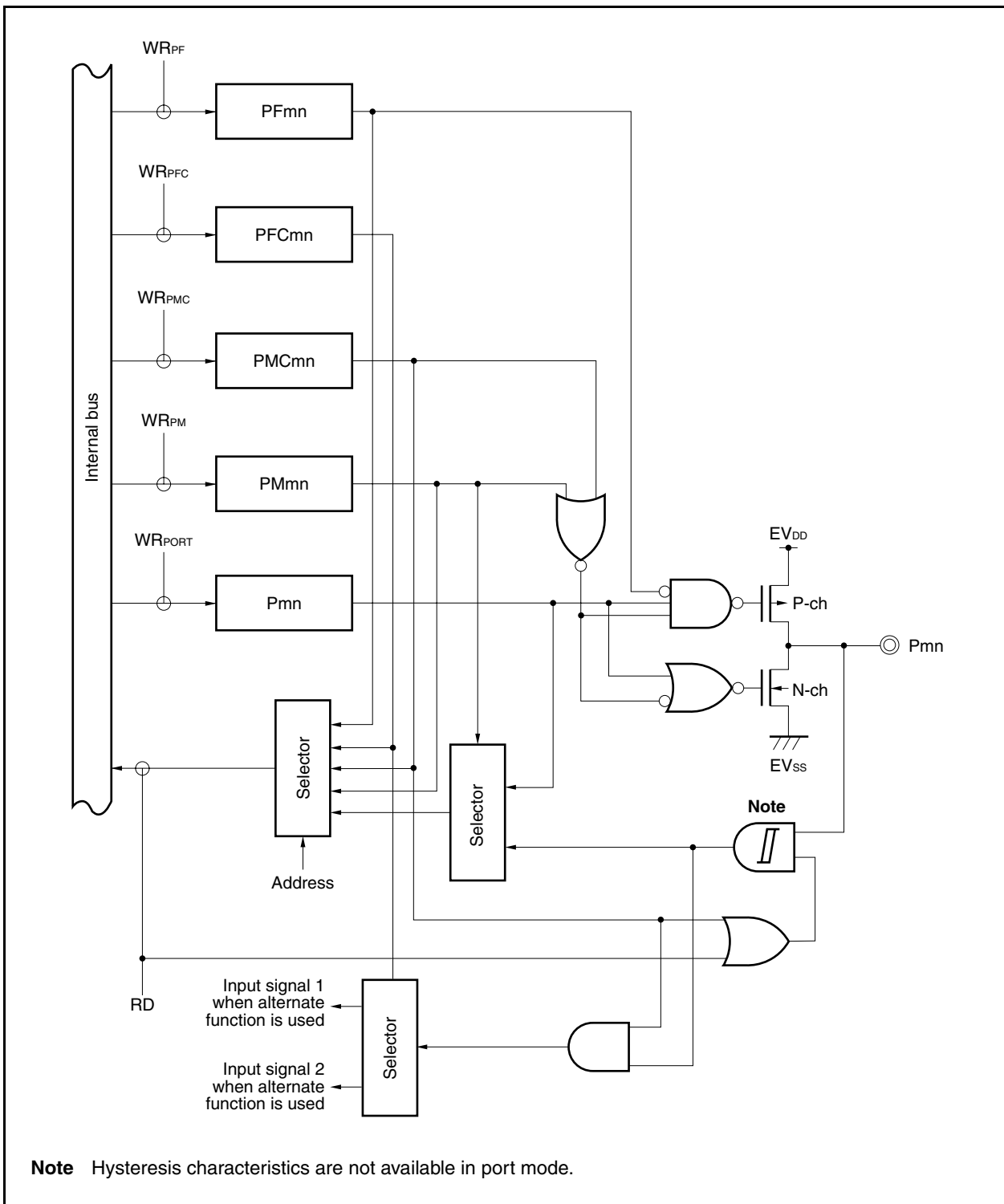
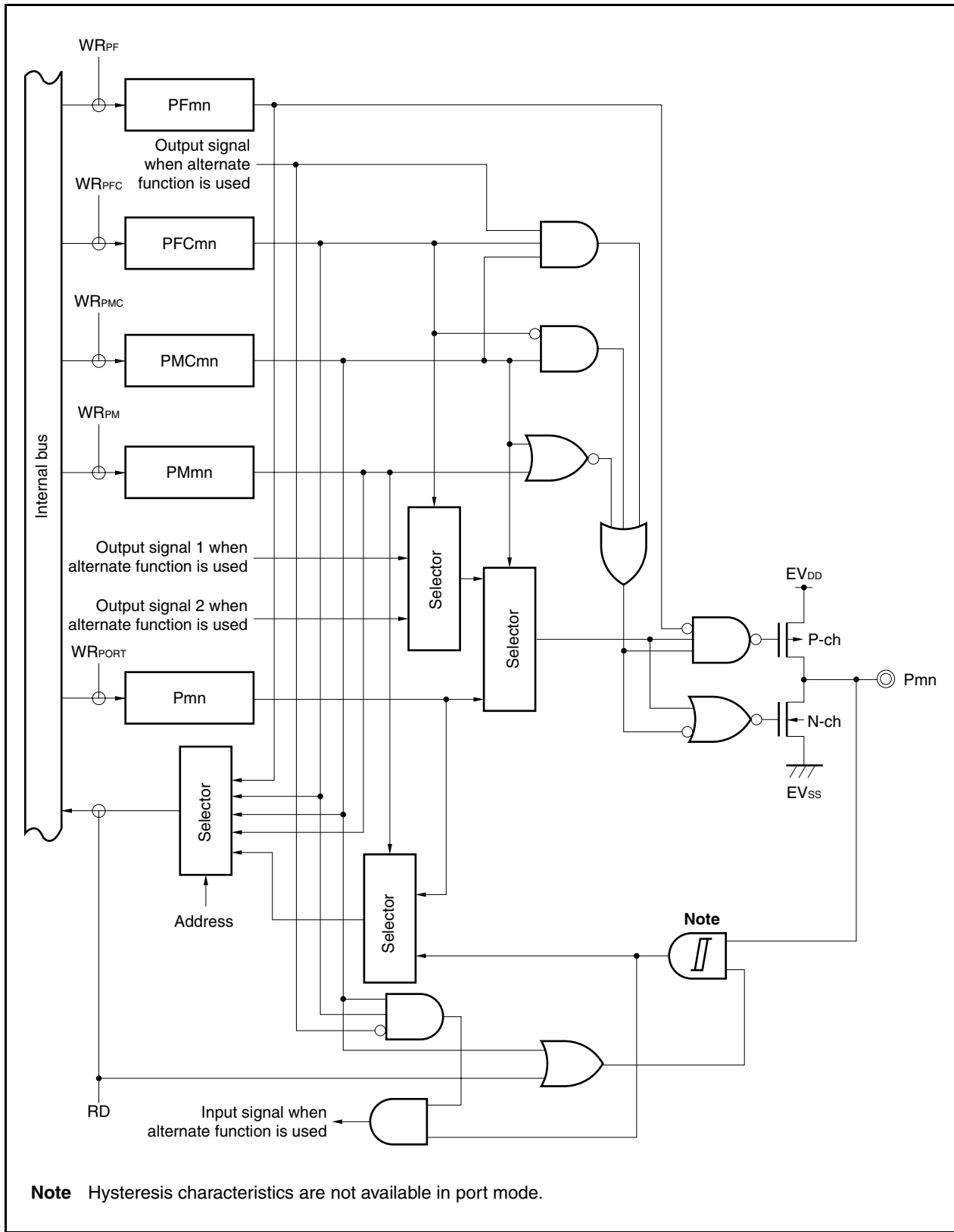

Figure 4-20. Block Diagram of Type G-4



**Note** Hysteresis characteristics are not available in port mode.



Figure 4-21. Block Diagram of Type G-5

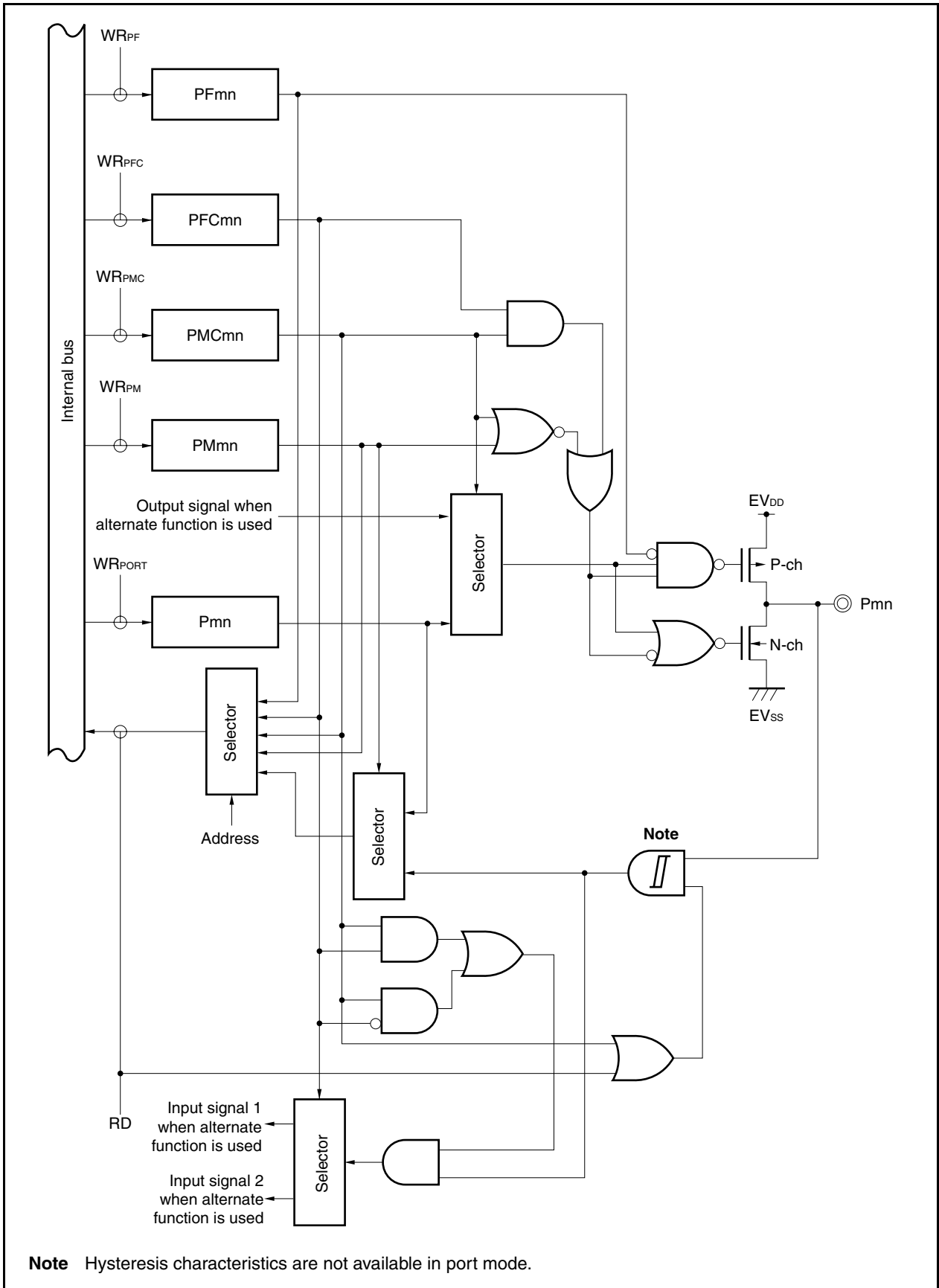
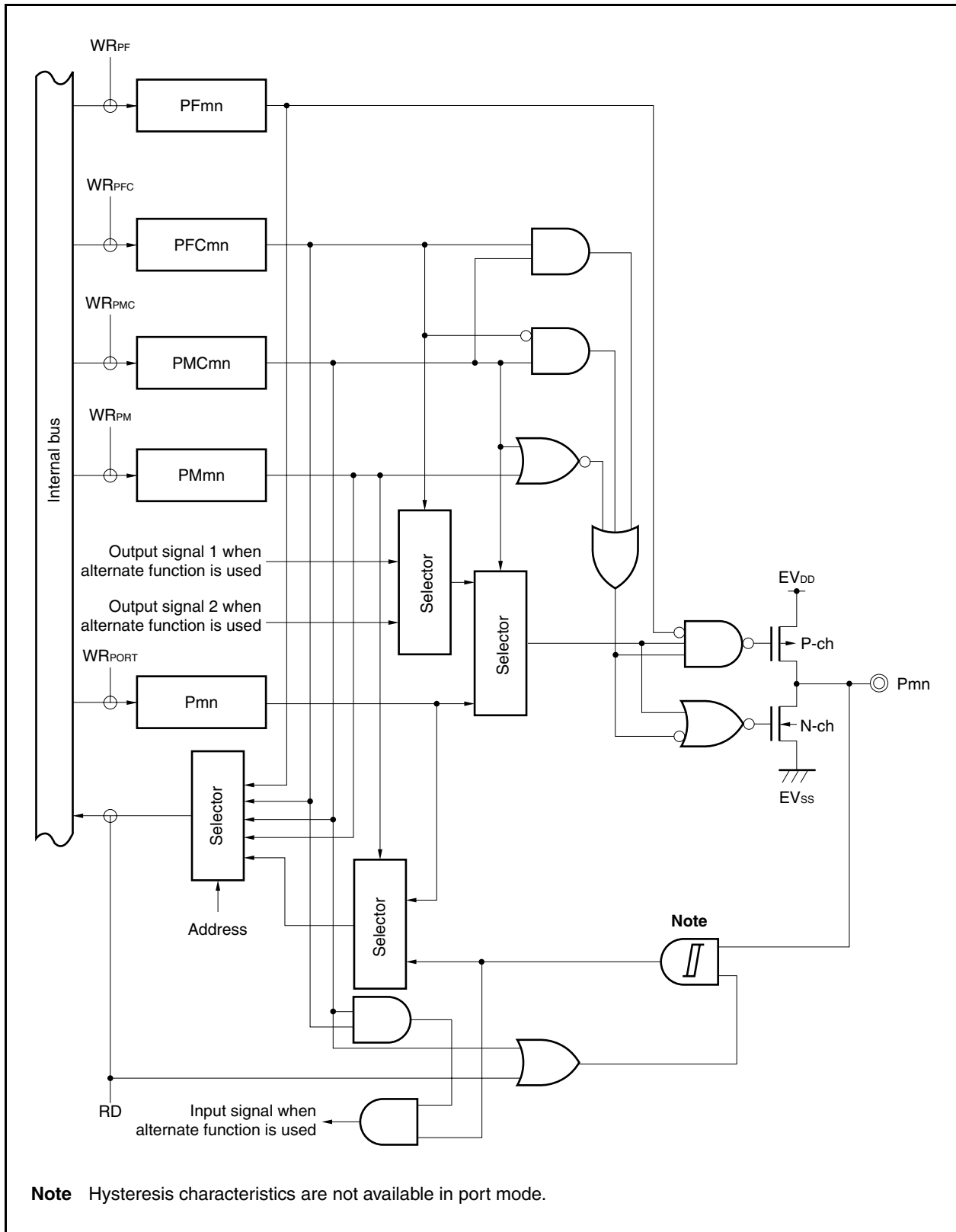

Figure 4-22. Block Diagram of Type G-6



**Note** Hysteresis characteristics are not available in port mode.

<R>

Figure 4-23. Block Diagram of Type G-7

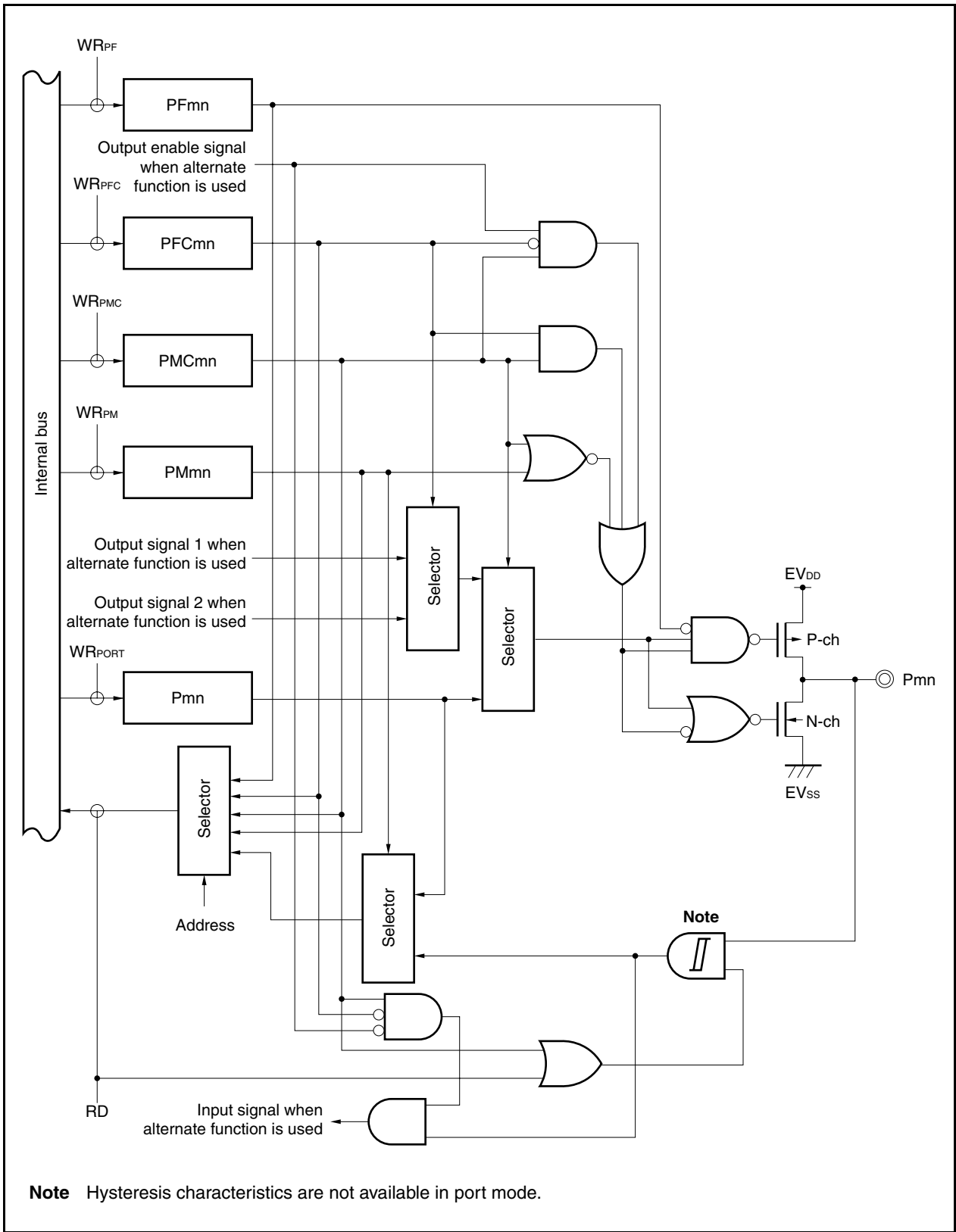

Figure 4-24. Block Diagram of Type L-1

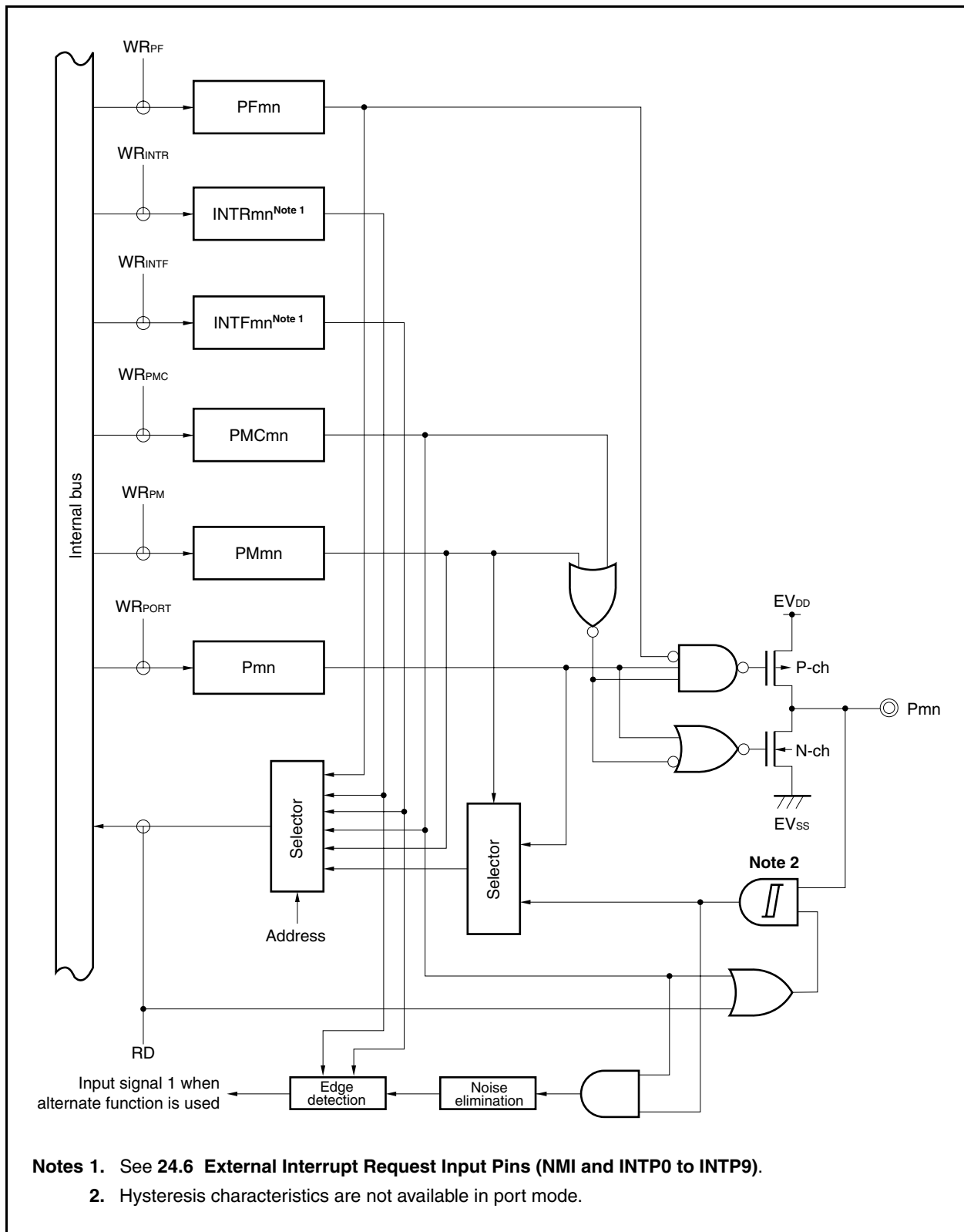
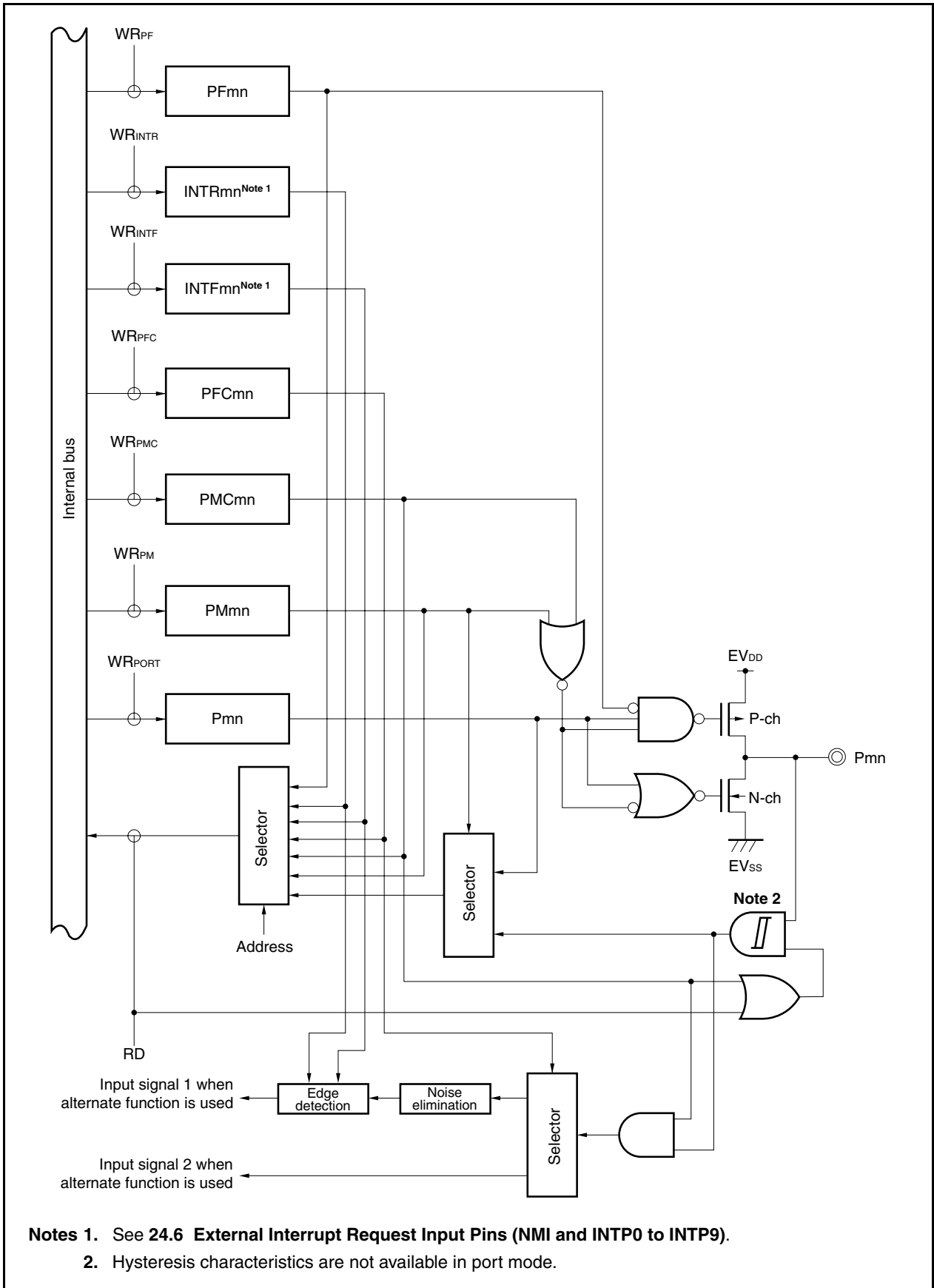
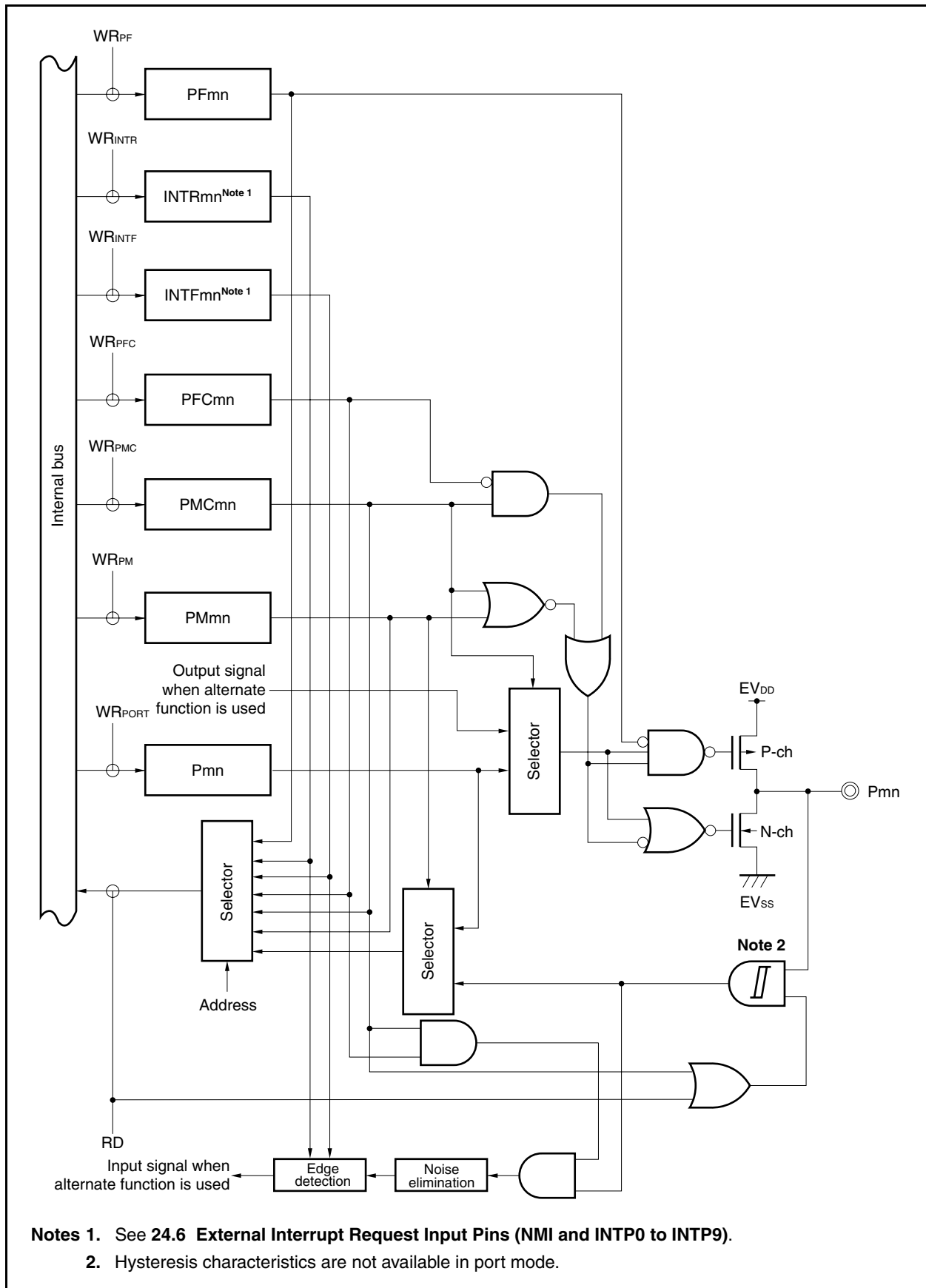

Figure 4-25. Block Diagram of Type N-1



- Notes 1.** See 24.6 External Interrupt Request Input Pins (NMI and INTP0 to INTP9).  
**2.** Hysteresis characteristics are not available in port mode.

Figure 4-26. Block Diagram of Type N-2



- Notes 1. See 24.6 External Interrupt Request Input Pins (NMI and INTP0 to INTP9).
- 2. Hysteresis characteristics are not available in port mode.

Figure 4-27. Block Diagram of Type N-3

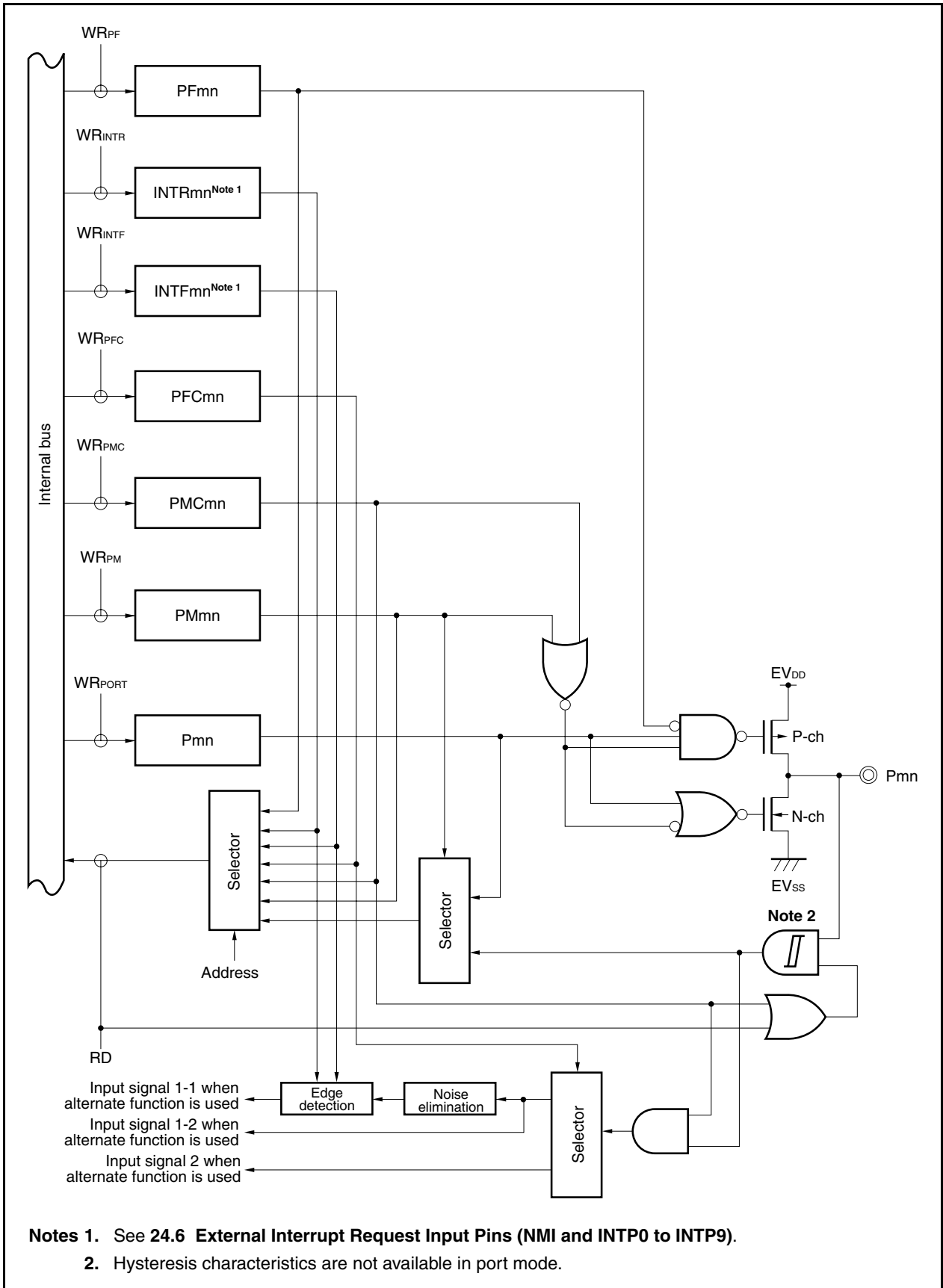
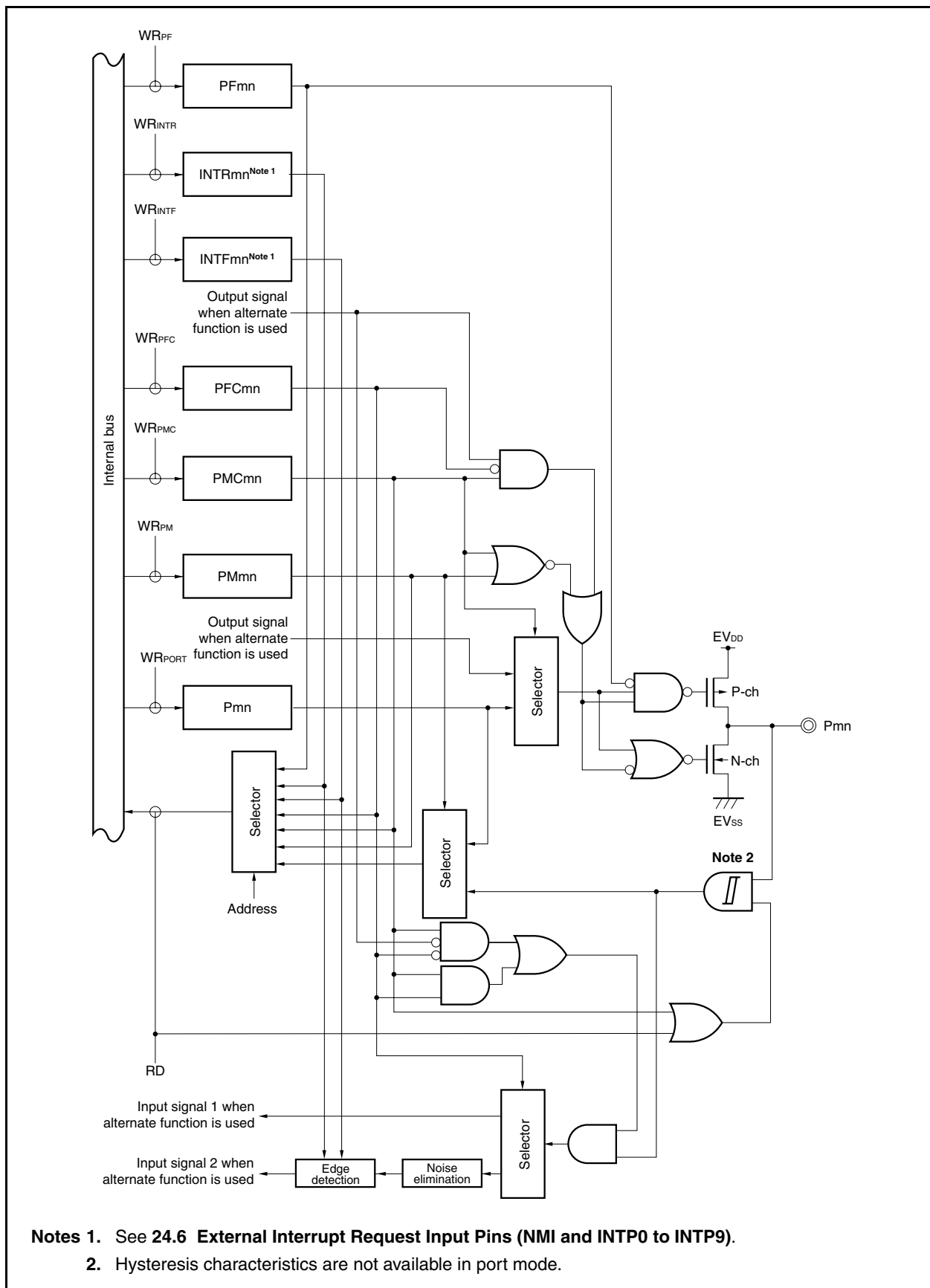

Figure 4-28. Block Diagram of Type N-4



Notes 1. See 24.6 External Interrupt Request Input Pins (NMI and INTP0 to INTP9).

2. Hysteresis characteristics are not available in port mode.



Figure 4-29. Block Diagram of Type U-1

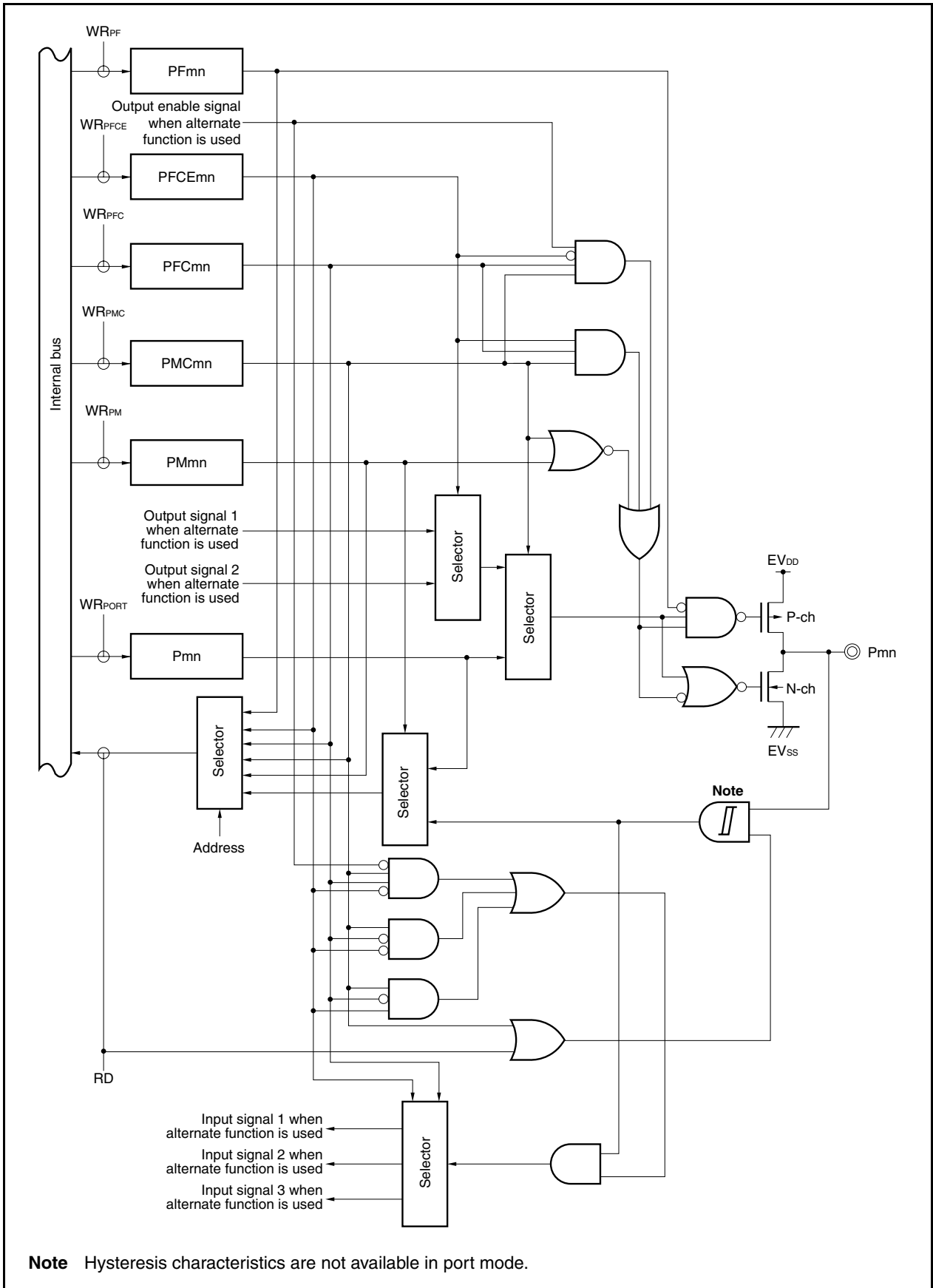

**Note** Hysteresis characteristics are not available in port mode.

Figure 4-30. Block Diagram of Type U-2

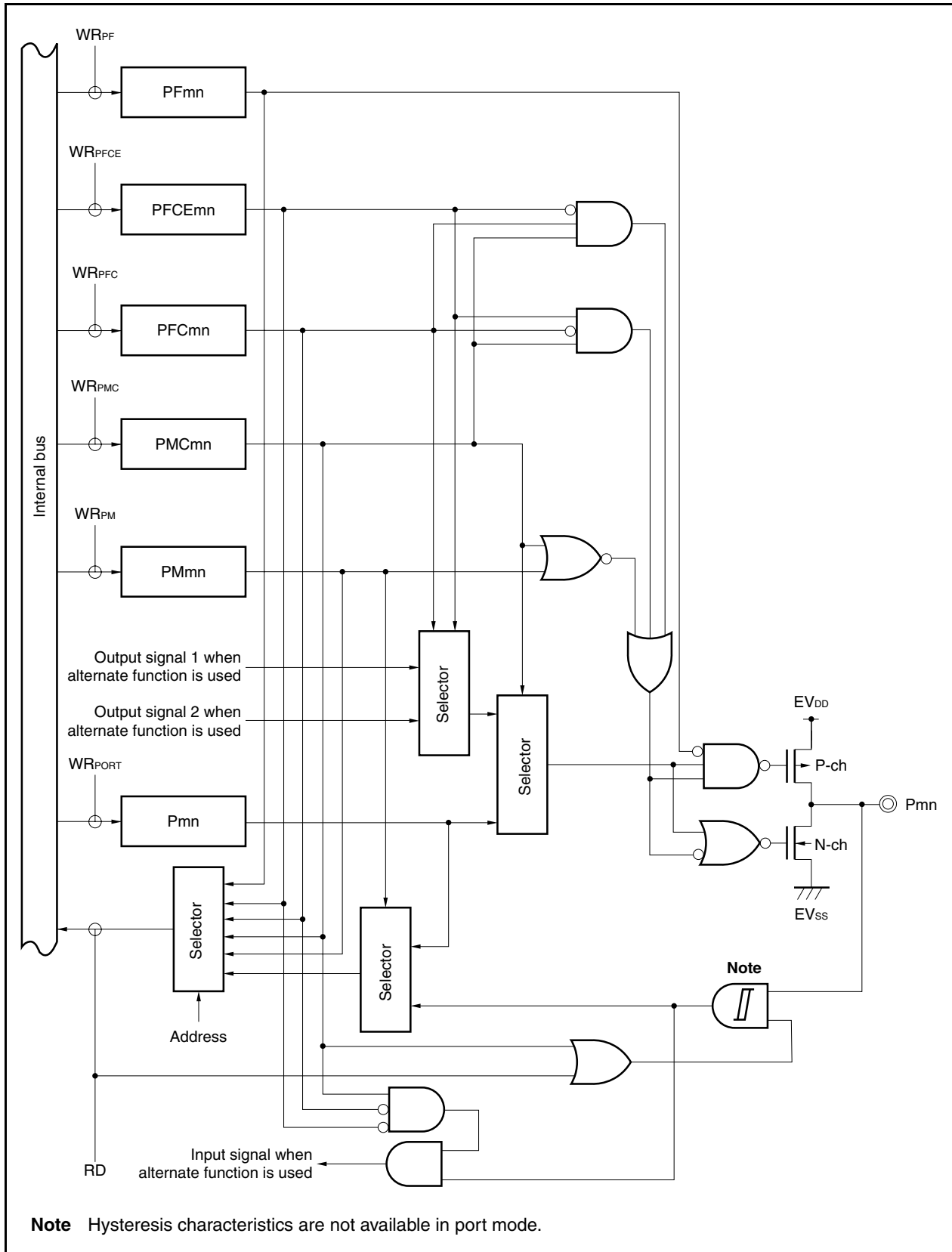

Figure 4-31. Block Diagram of Type U-3

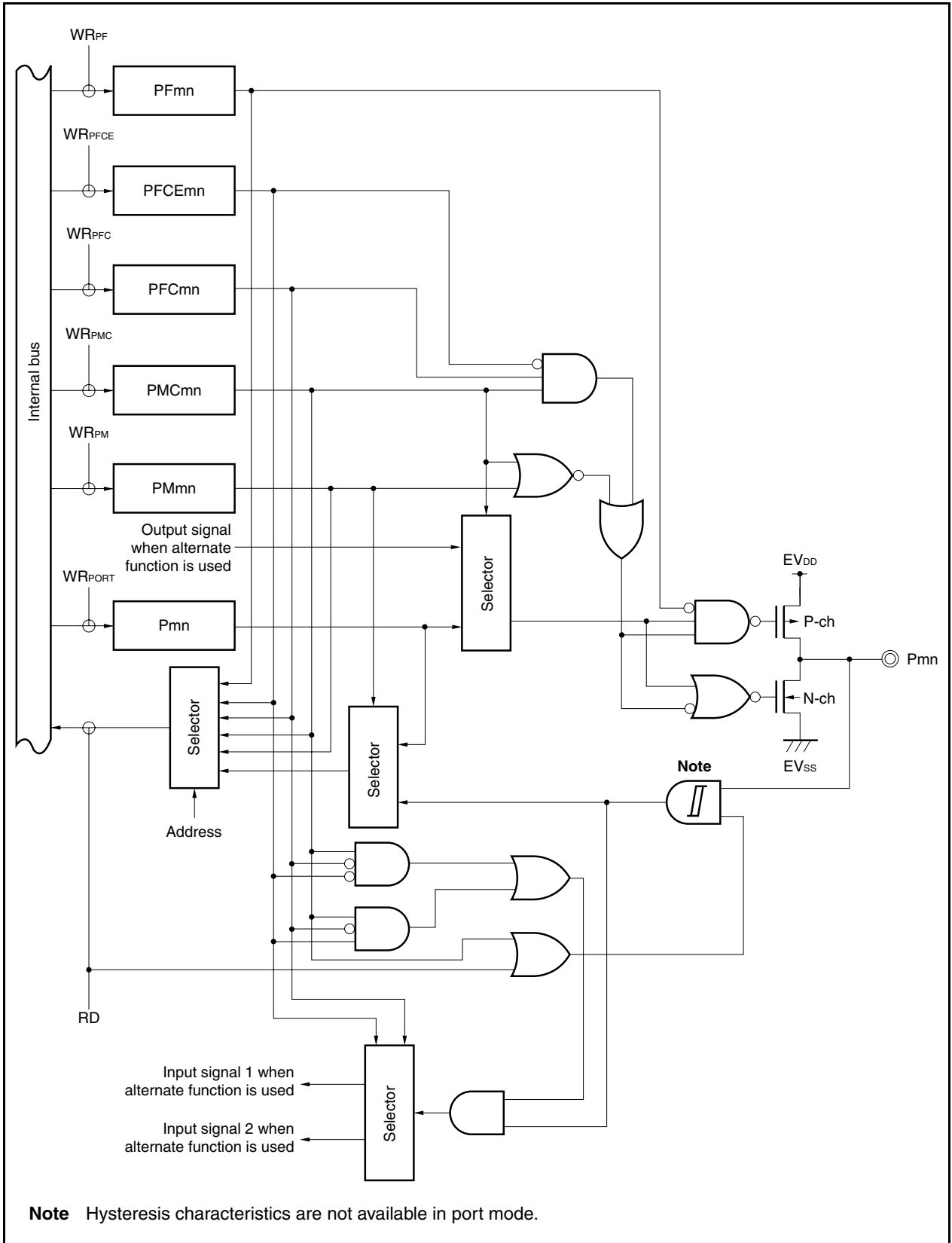
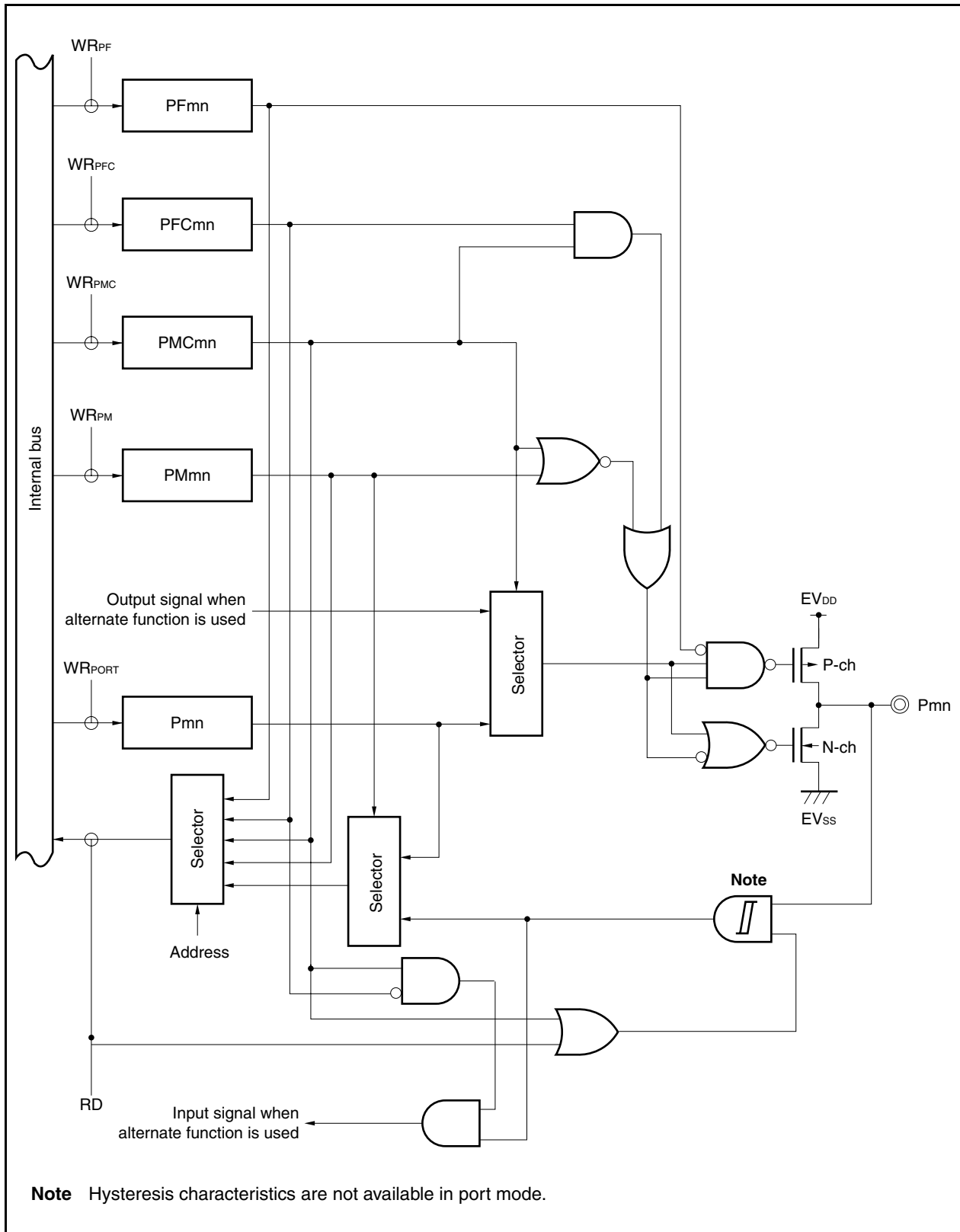

Figure 4-32. Block Diagram of Type U-4



**Note** Hysteresis characteristics are not available in port mode.

Figure 4-33. Block Diagram of Type U-5

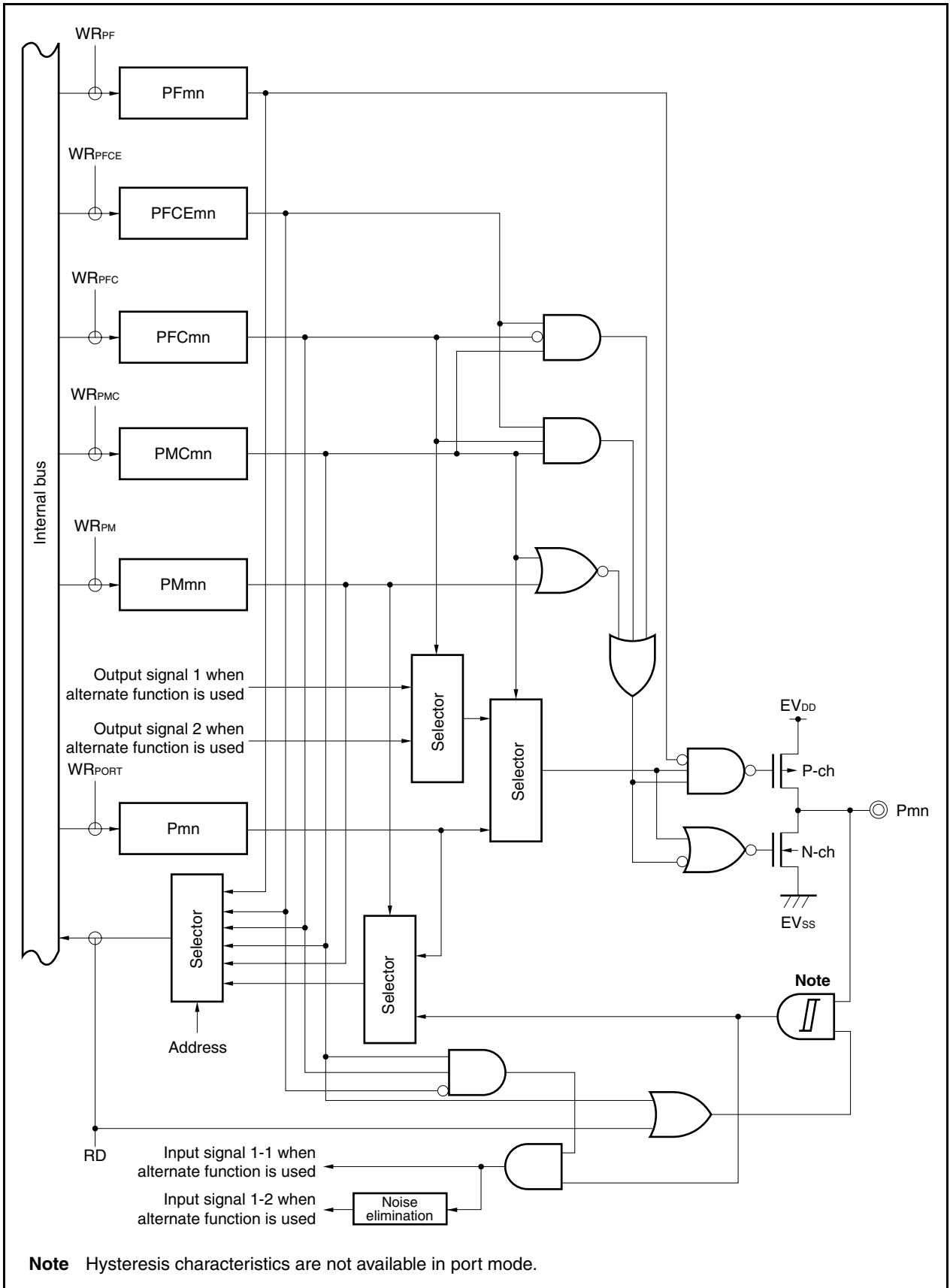

Figure 4-34. Block Diagram of Type U-6

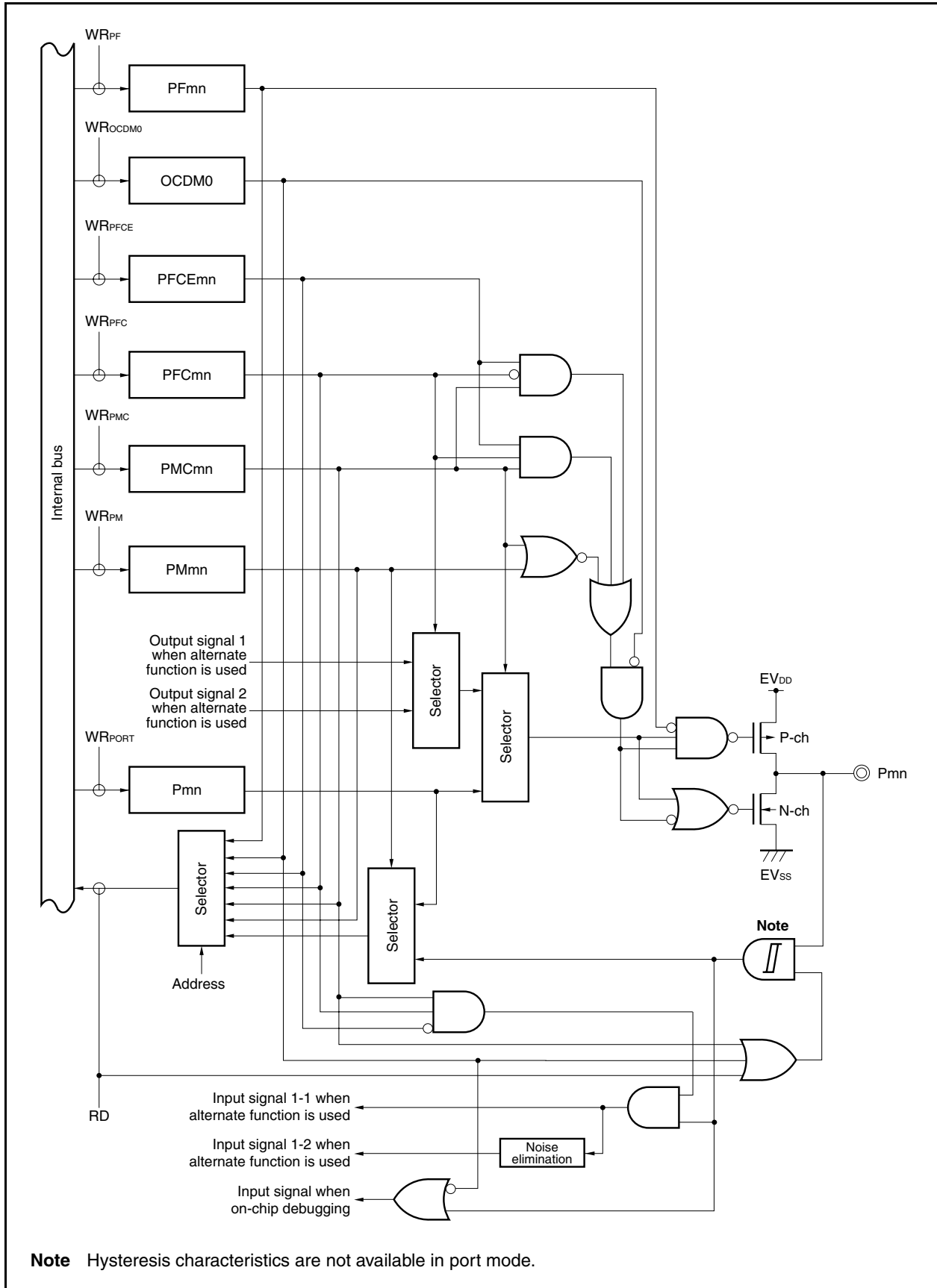

Figure 4-35. Block Diagram of Type U-7

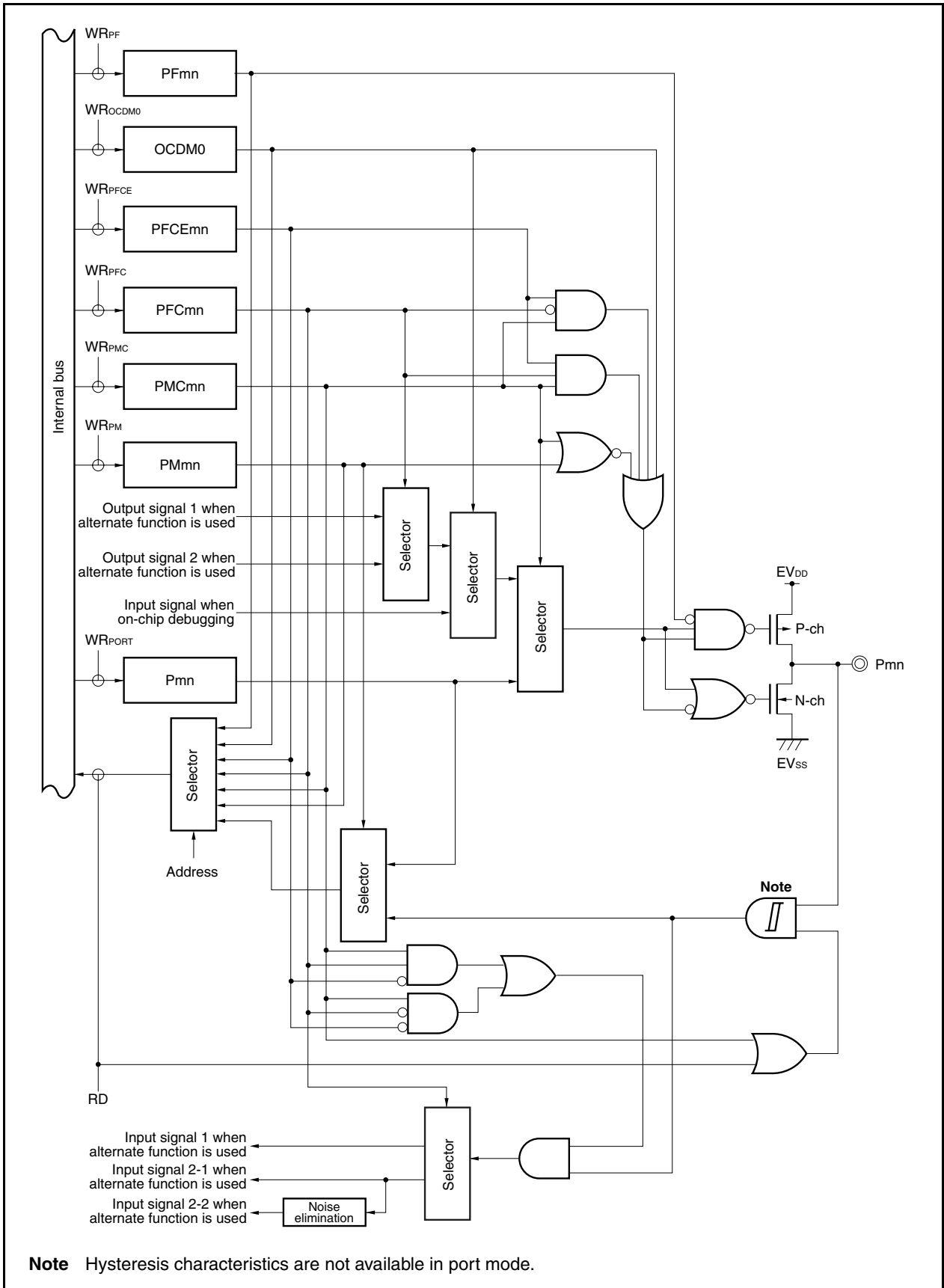

Figure 4-36. Block Diagram of Type U-8

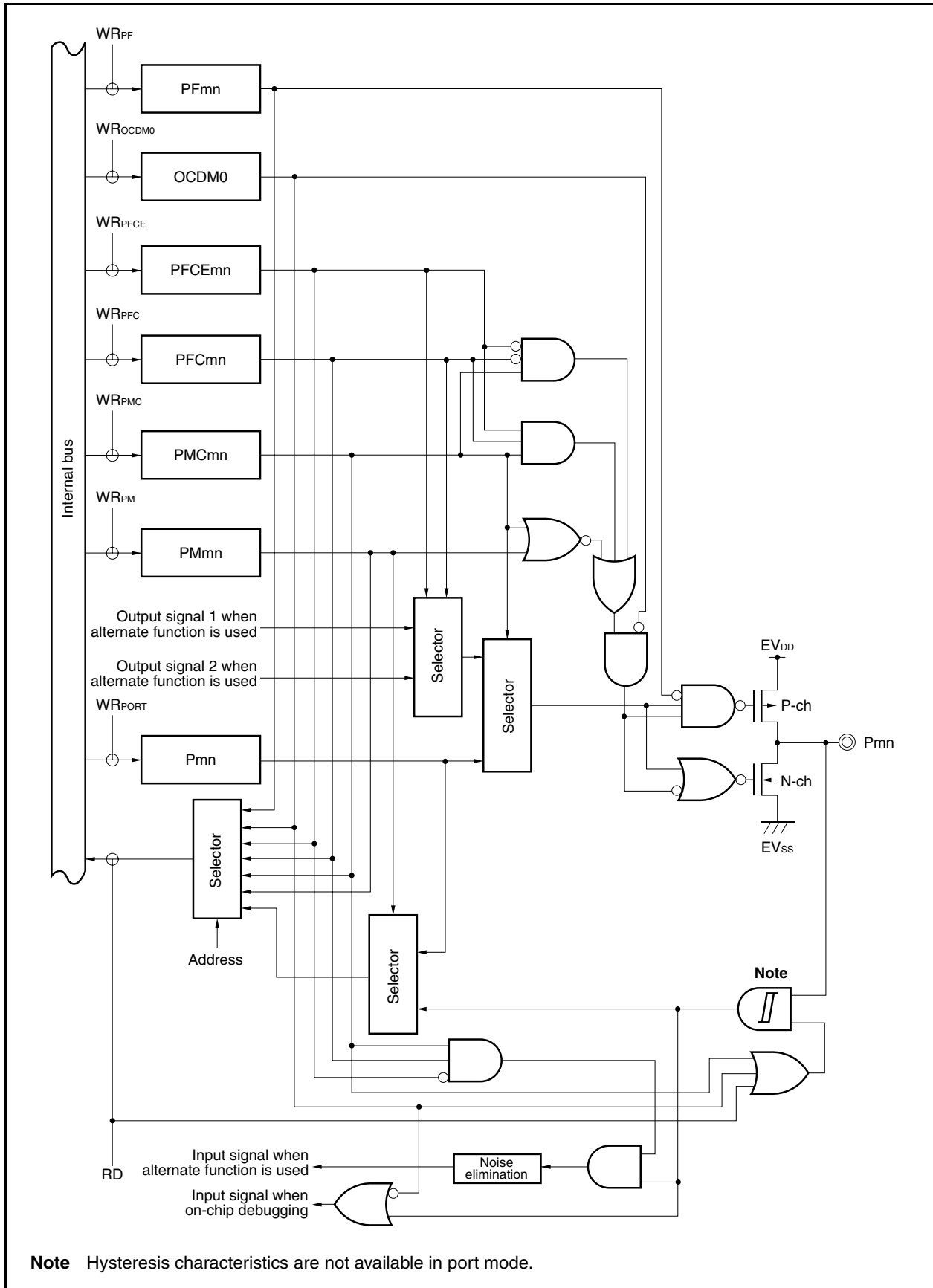



Figure 4-37. Block Diagram of Type U-9

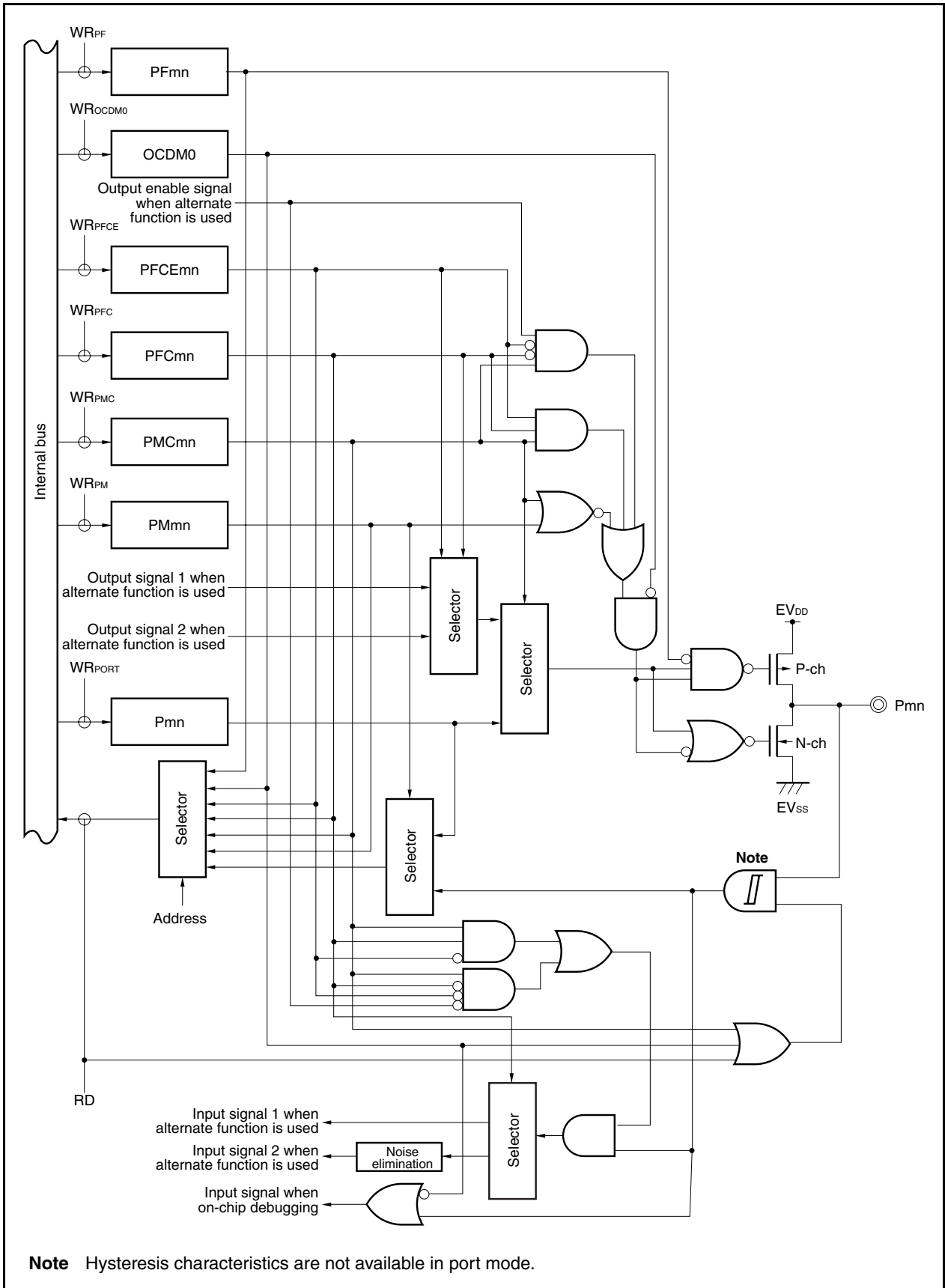

Figure 4-38. Block Diagram of Type U-10

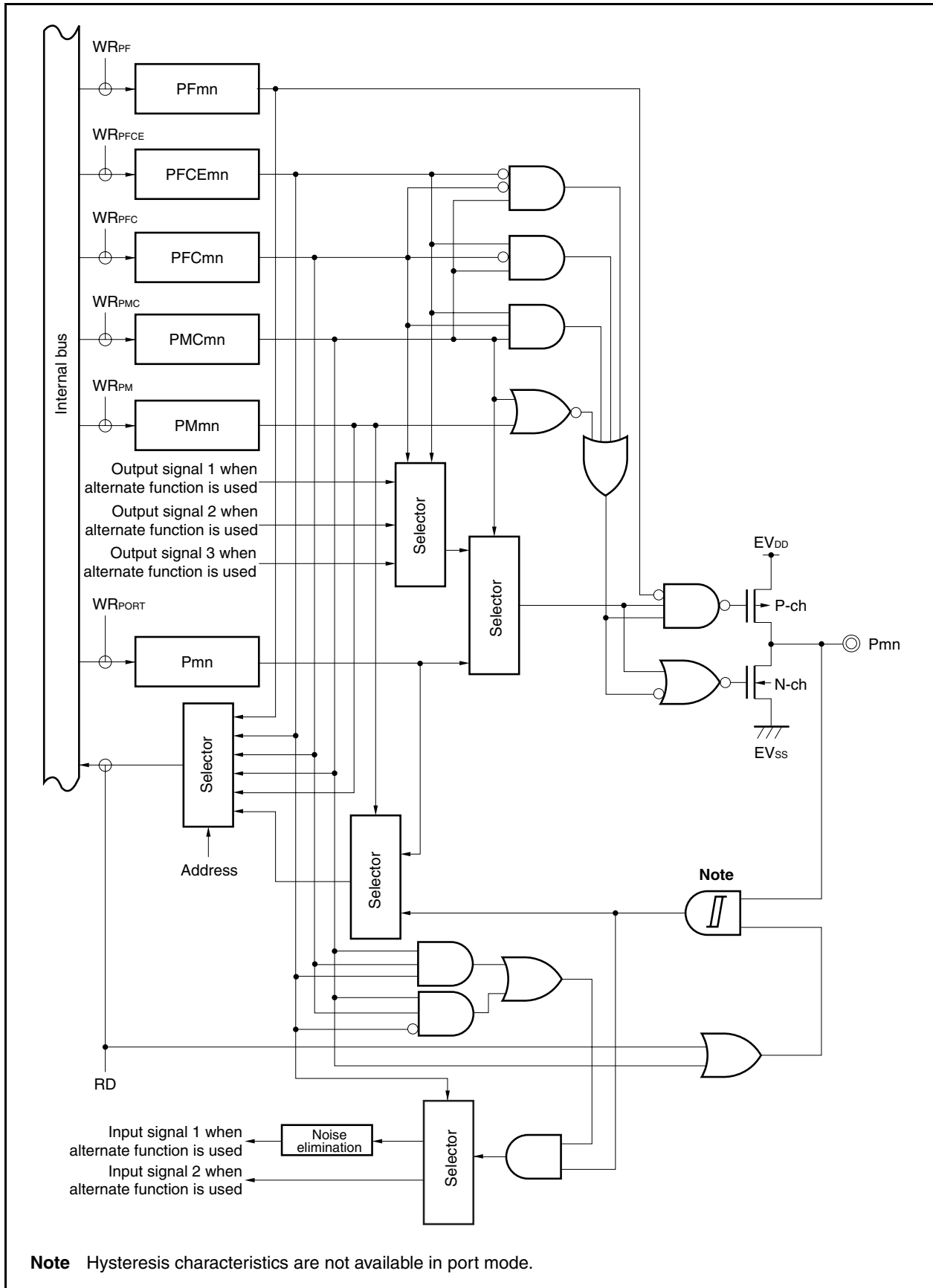

Figure 4-39. Block Diagram of Type U-11

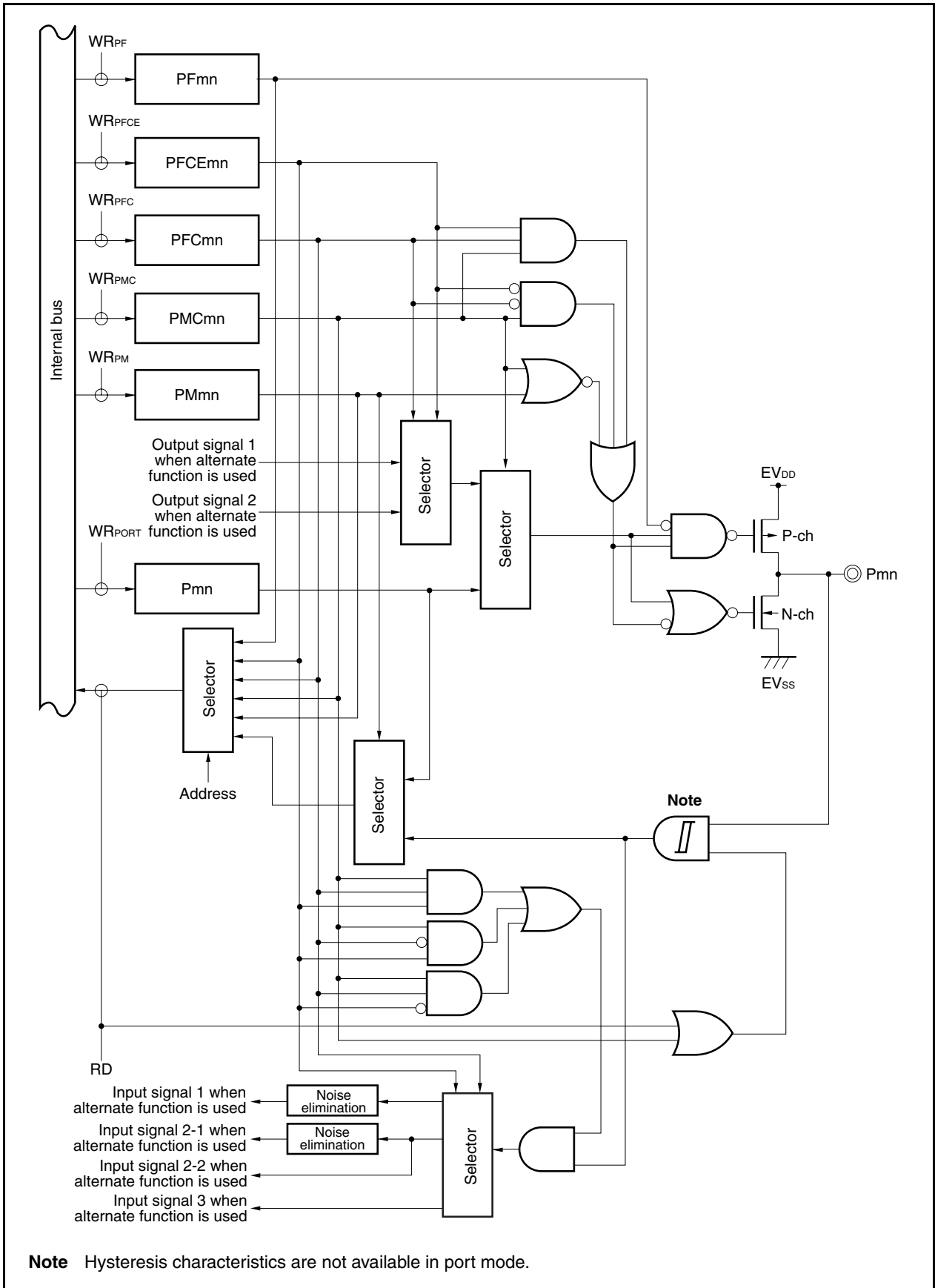

Figure 4-40. Block Diagram of Type U-12

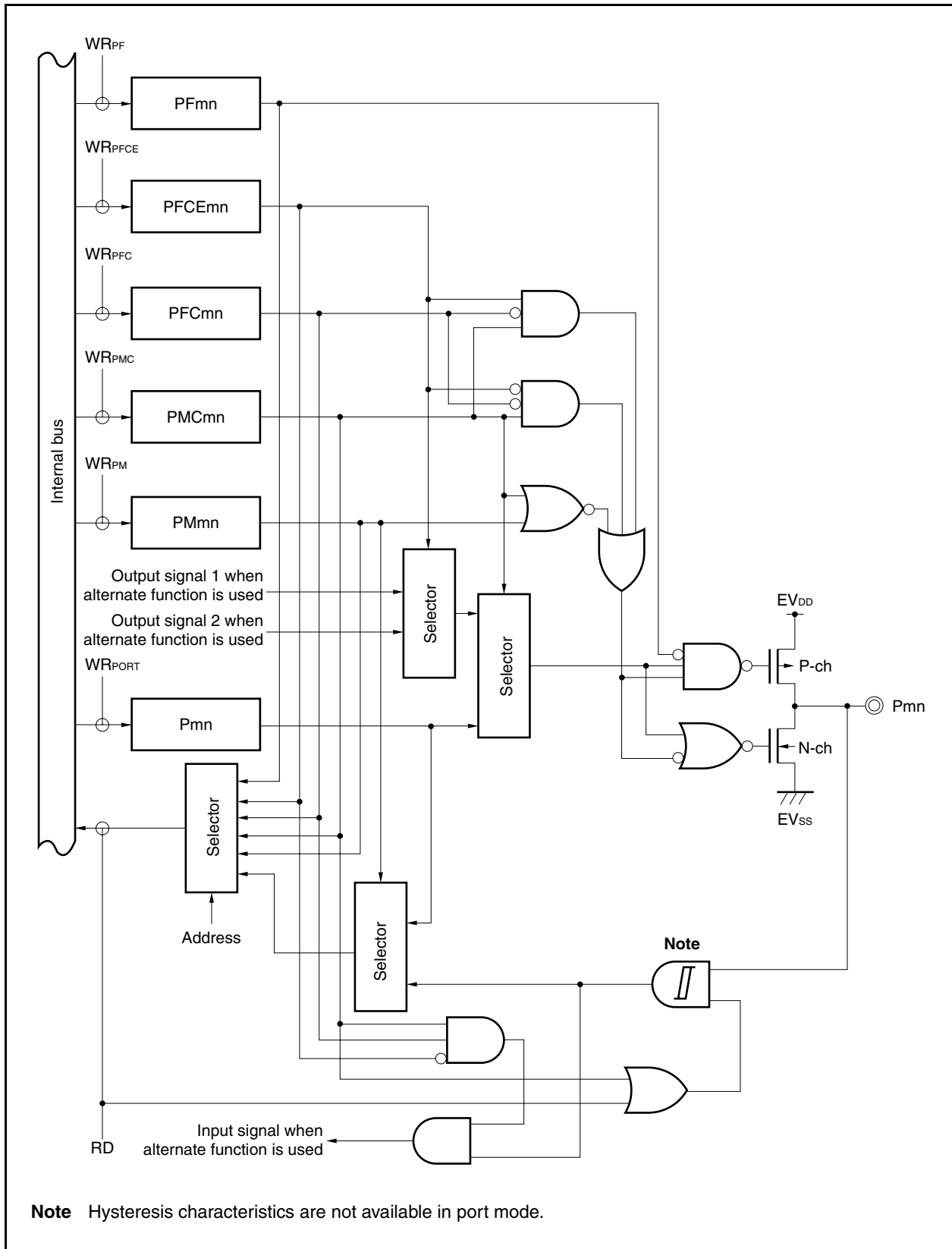
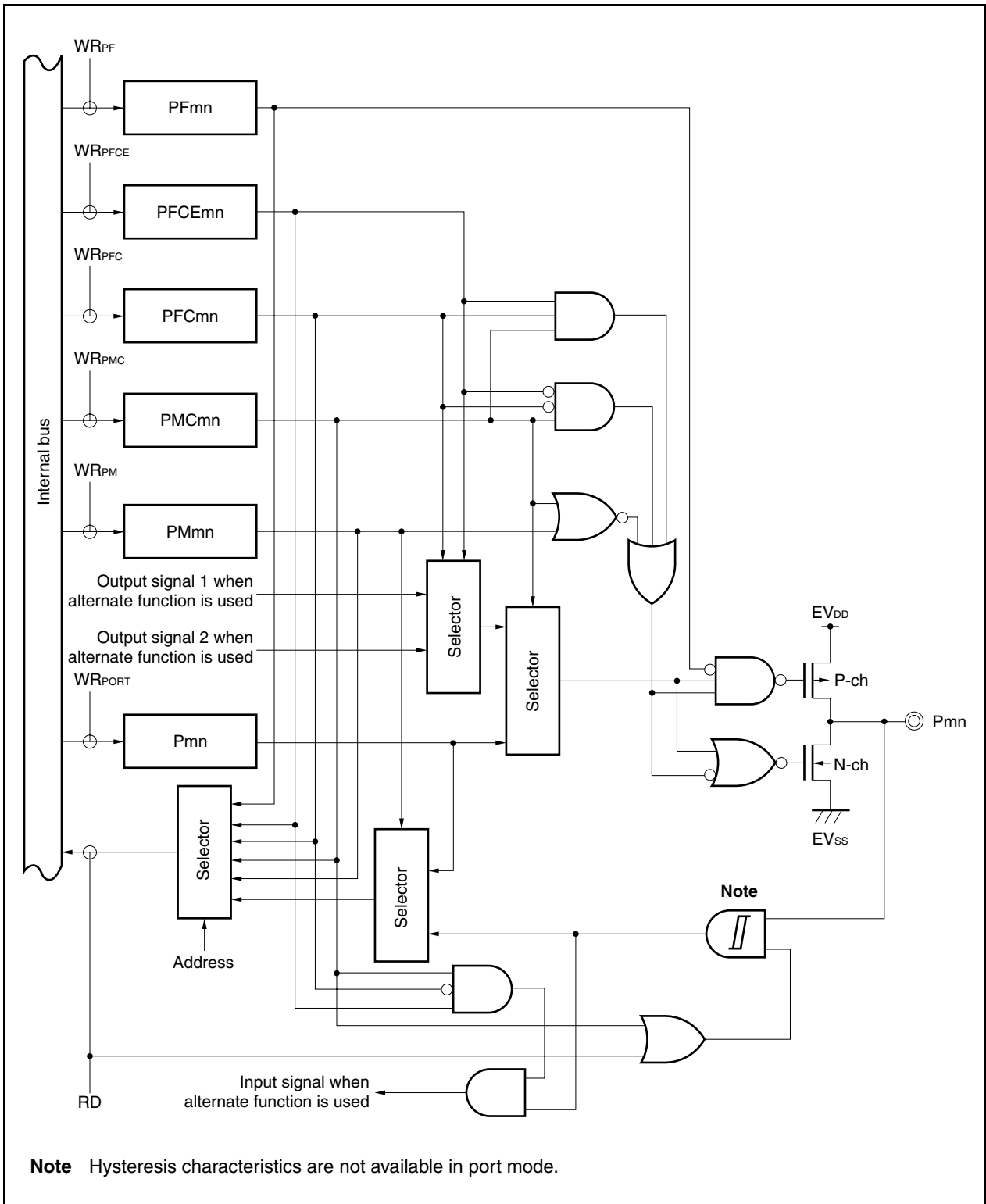

Figure 4-41. Block Diagram of Type U-13



**Note** Hysteresis characteristics are not available in port mode.

Figure 4-42. Block Diagram of Type U-14

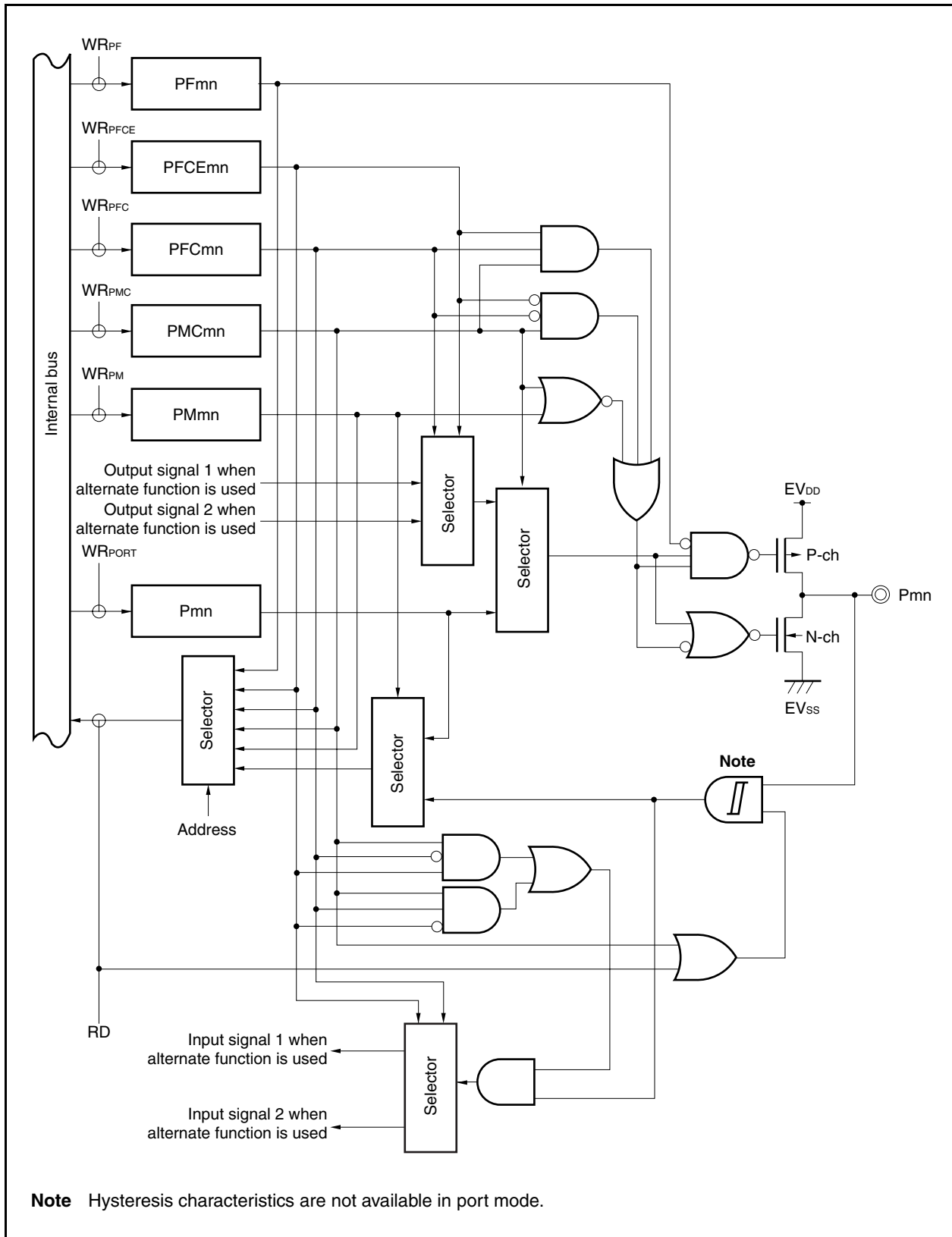
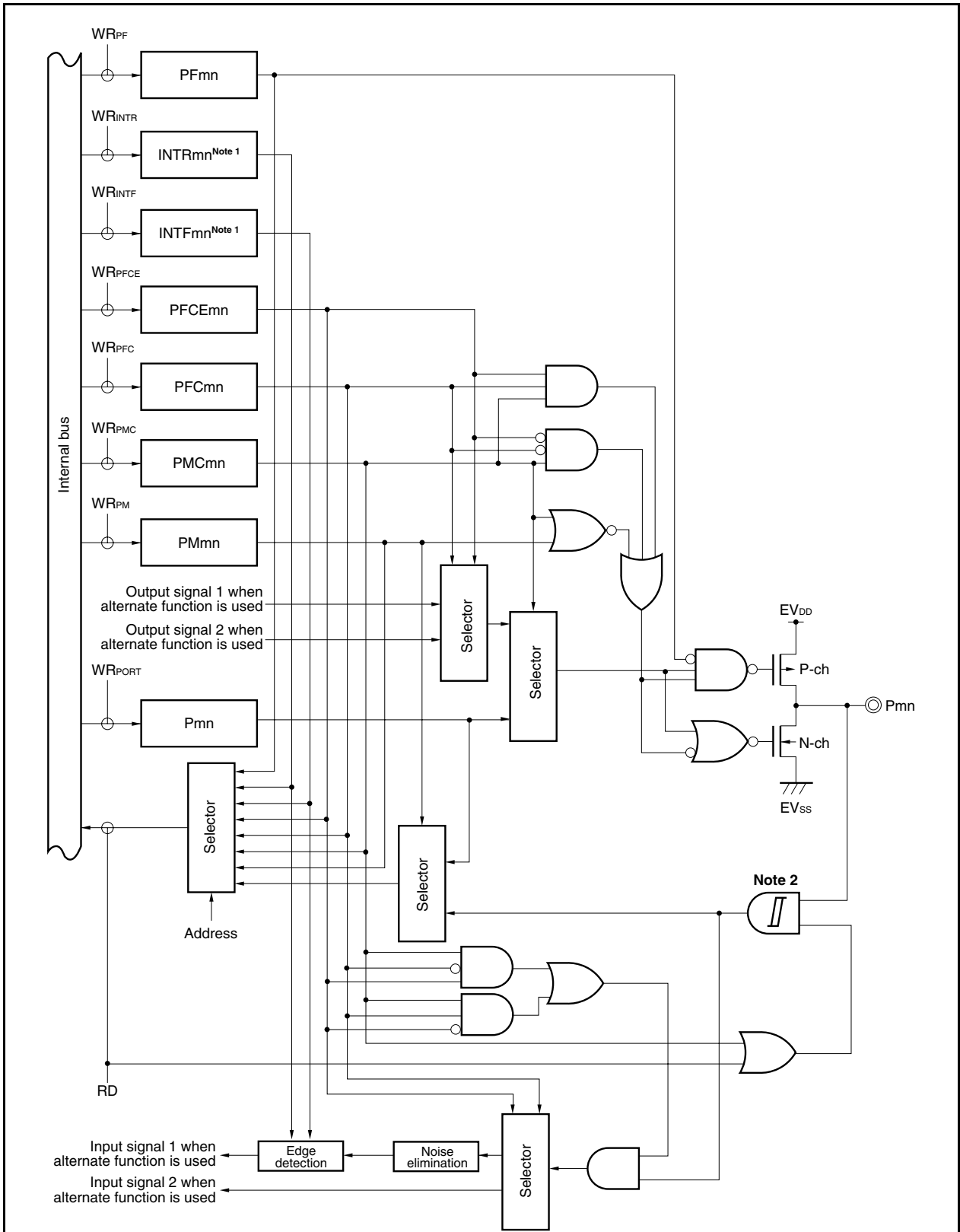

Figure 4-43. Block Diagram of Type U-15



- Notes 1. See 24.6 External Interrupt Request Input Pins (NMI and INTP0 to INTP9).
- 2. Hysteresis characteristics are not available in port mode.

Figure 4-44. Block Diagram of Type U-16

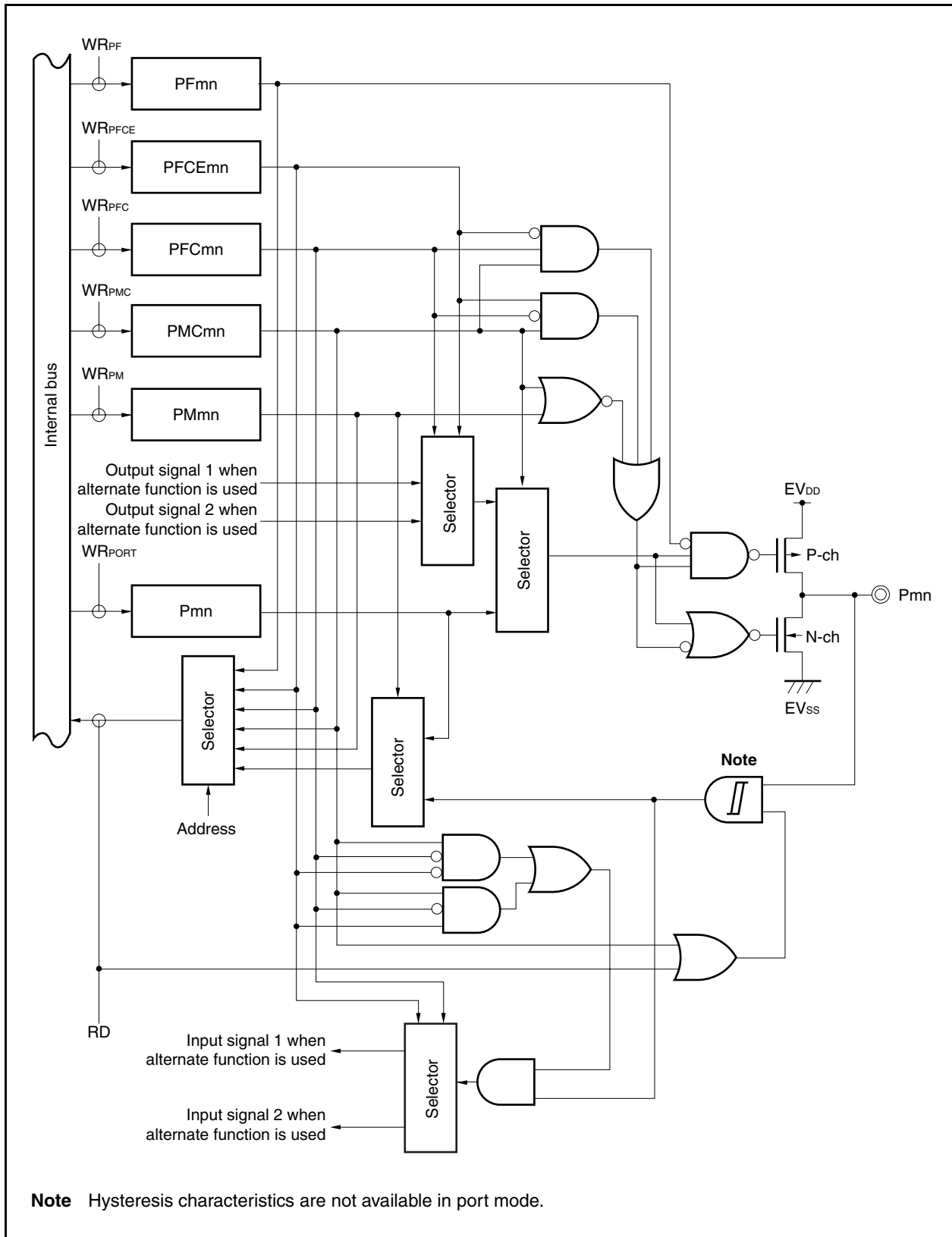



Figure 4-45. Block Diagram of Type U-17

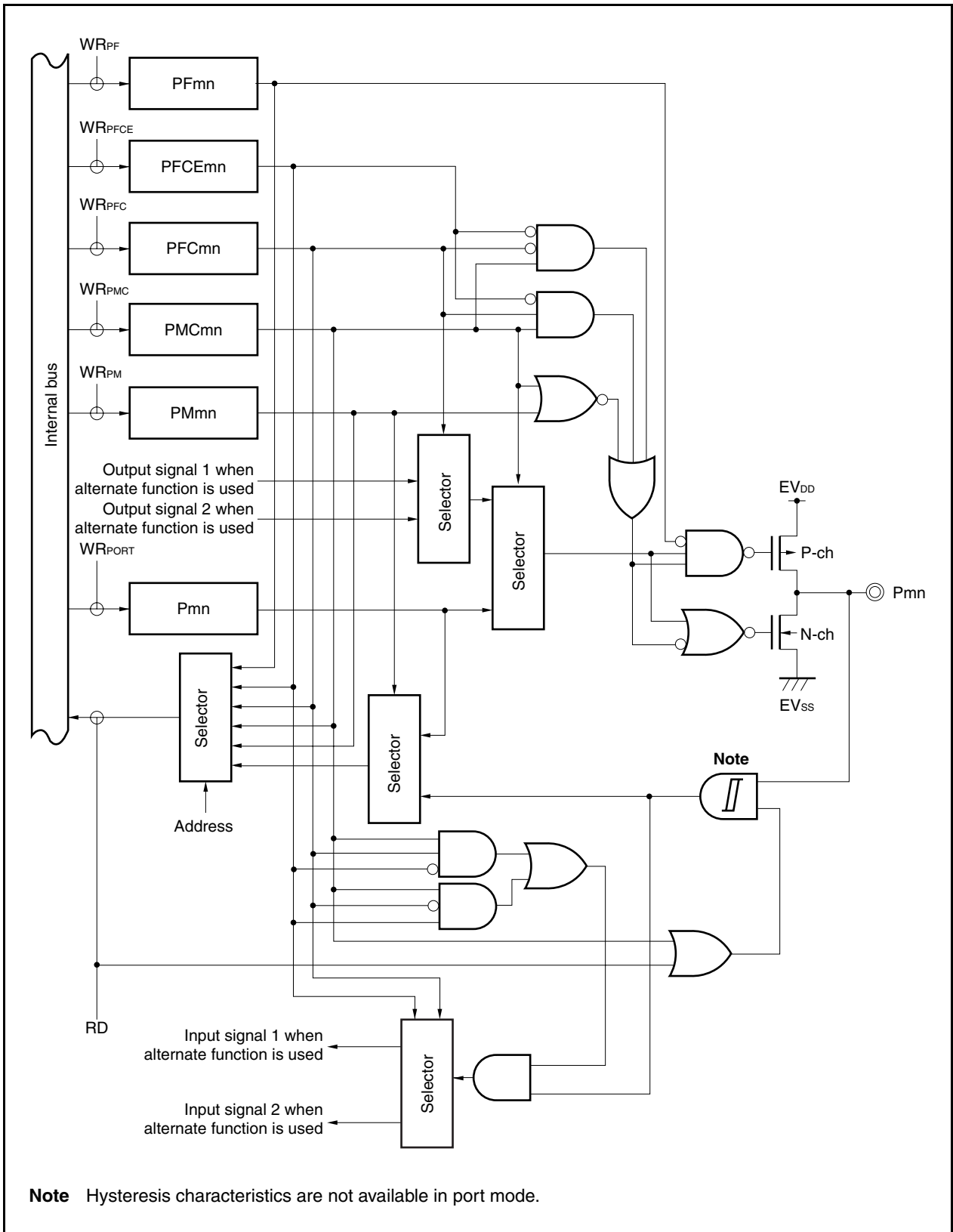
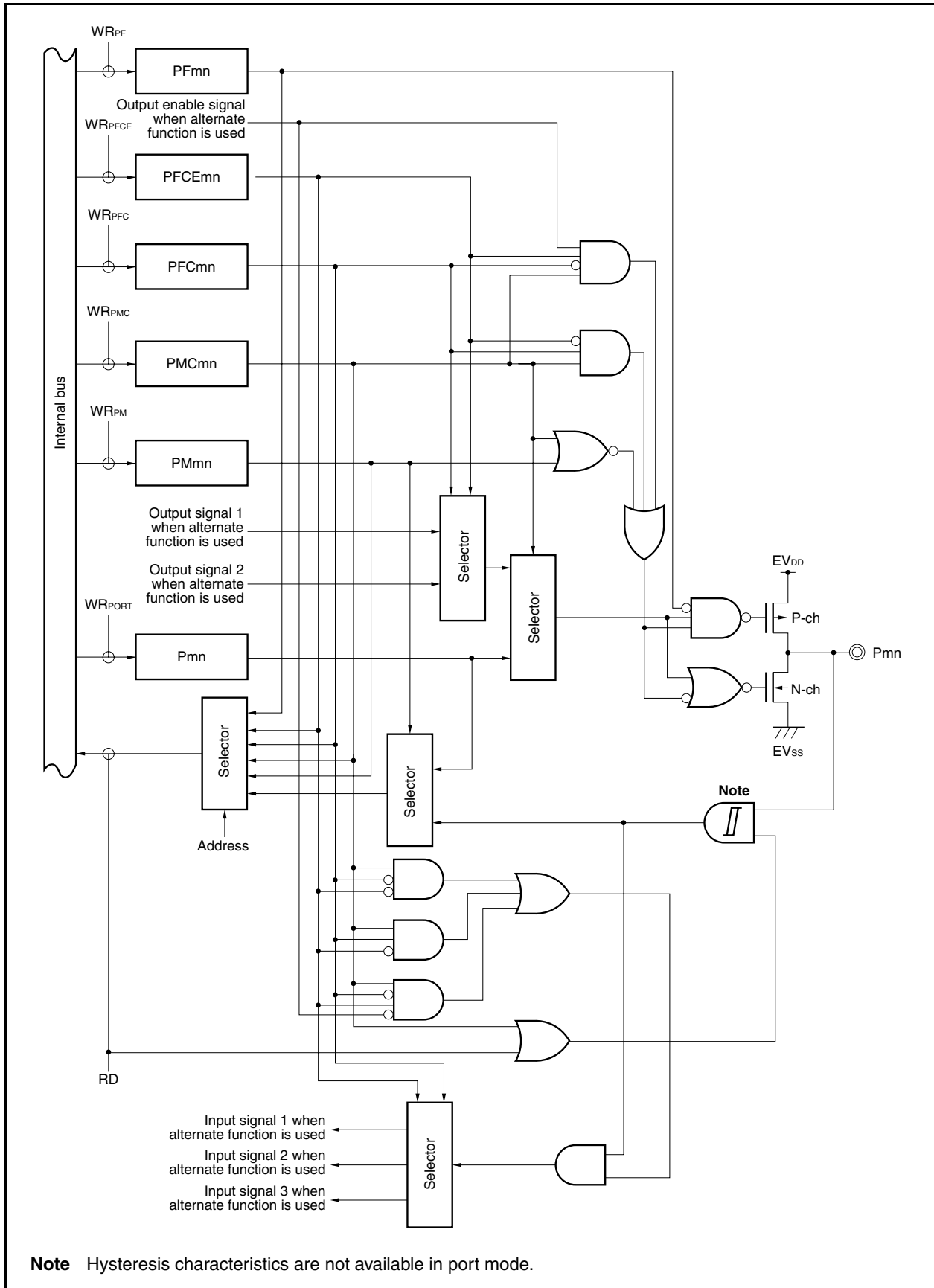

Figure 4-46. Block Diagram of Type U-18



**Note** Hysteresis characteristics are not available in port mode.

Figure 4-47. Block Diagram of Type U-19

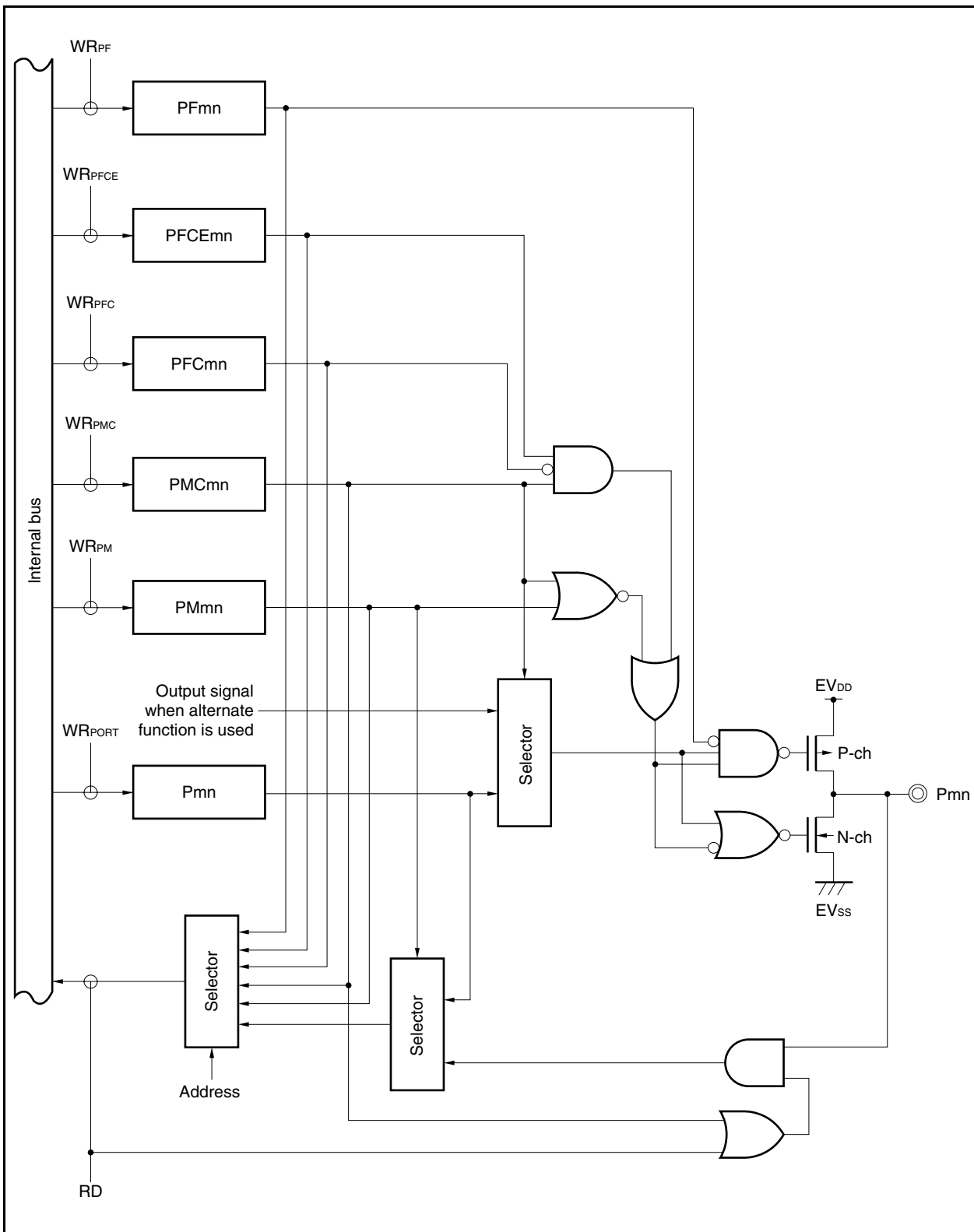

Figure 4-48. Block Diagram of Type U-20

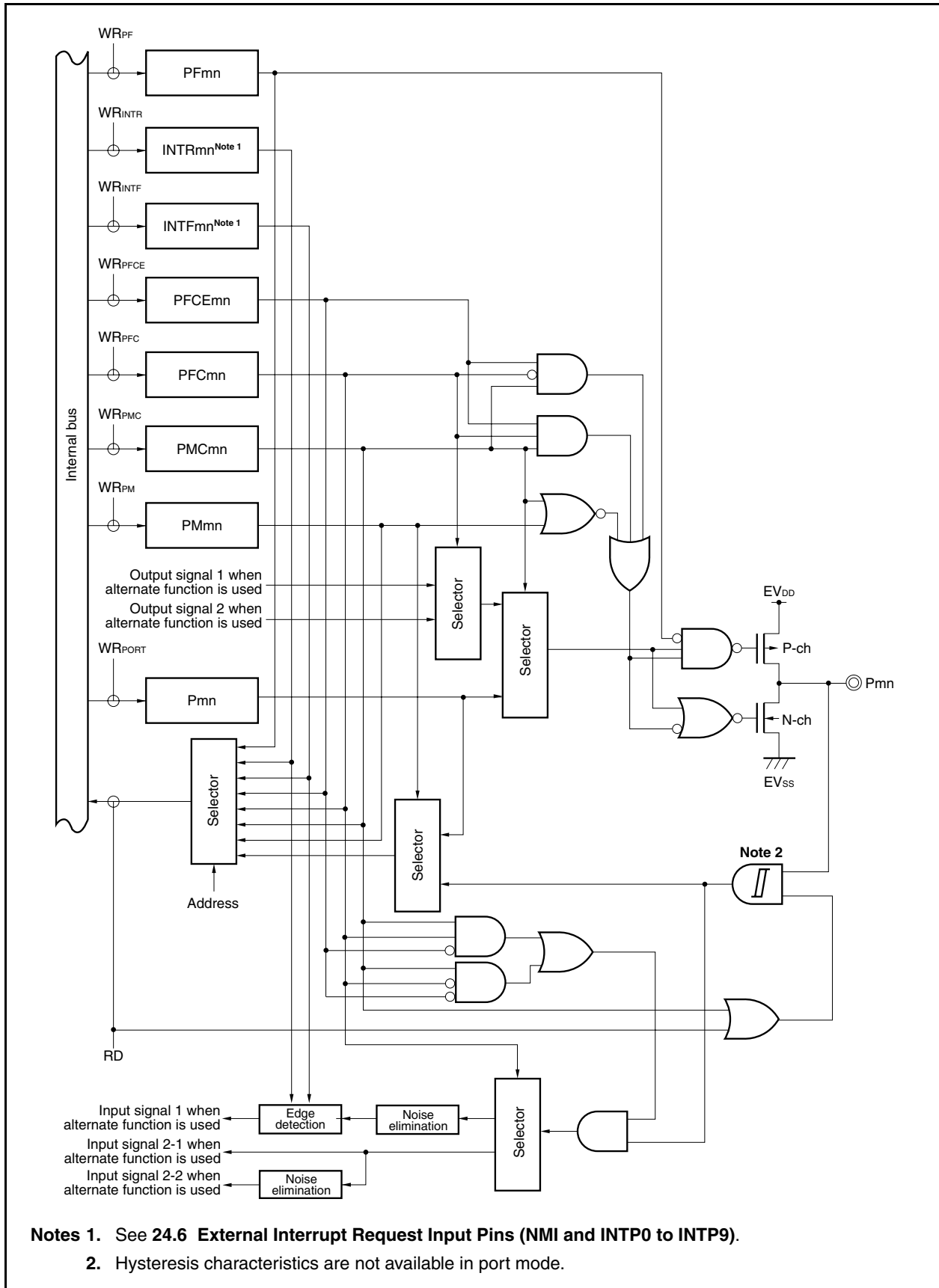

Figure 4-49. Block Diagram of Type U-21

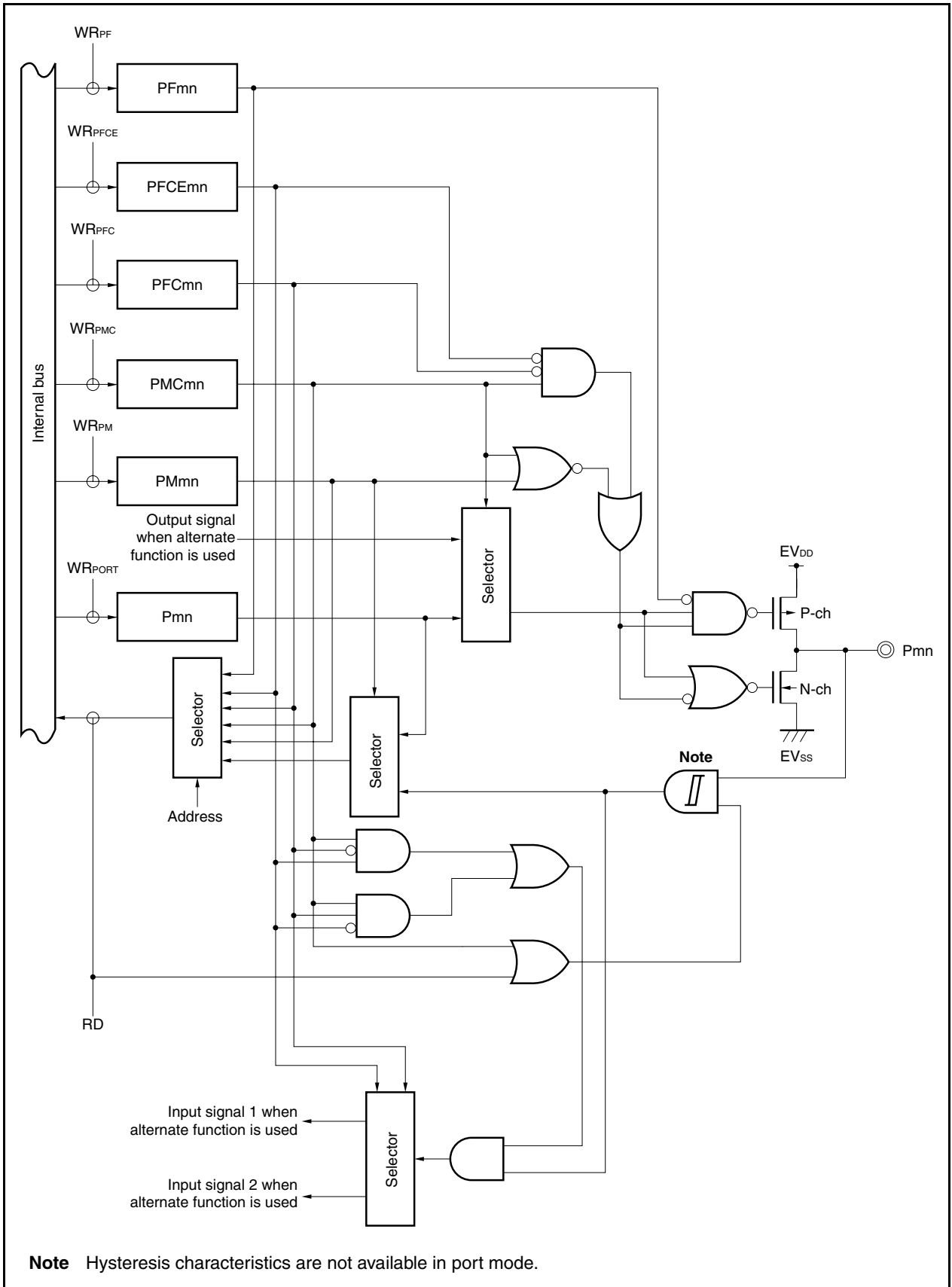

Figure 4-50. Block Diagram of Type U-22

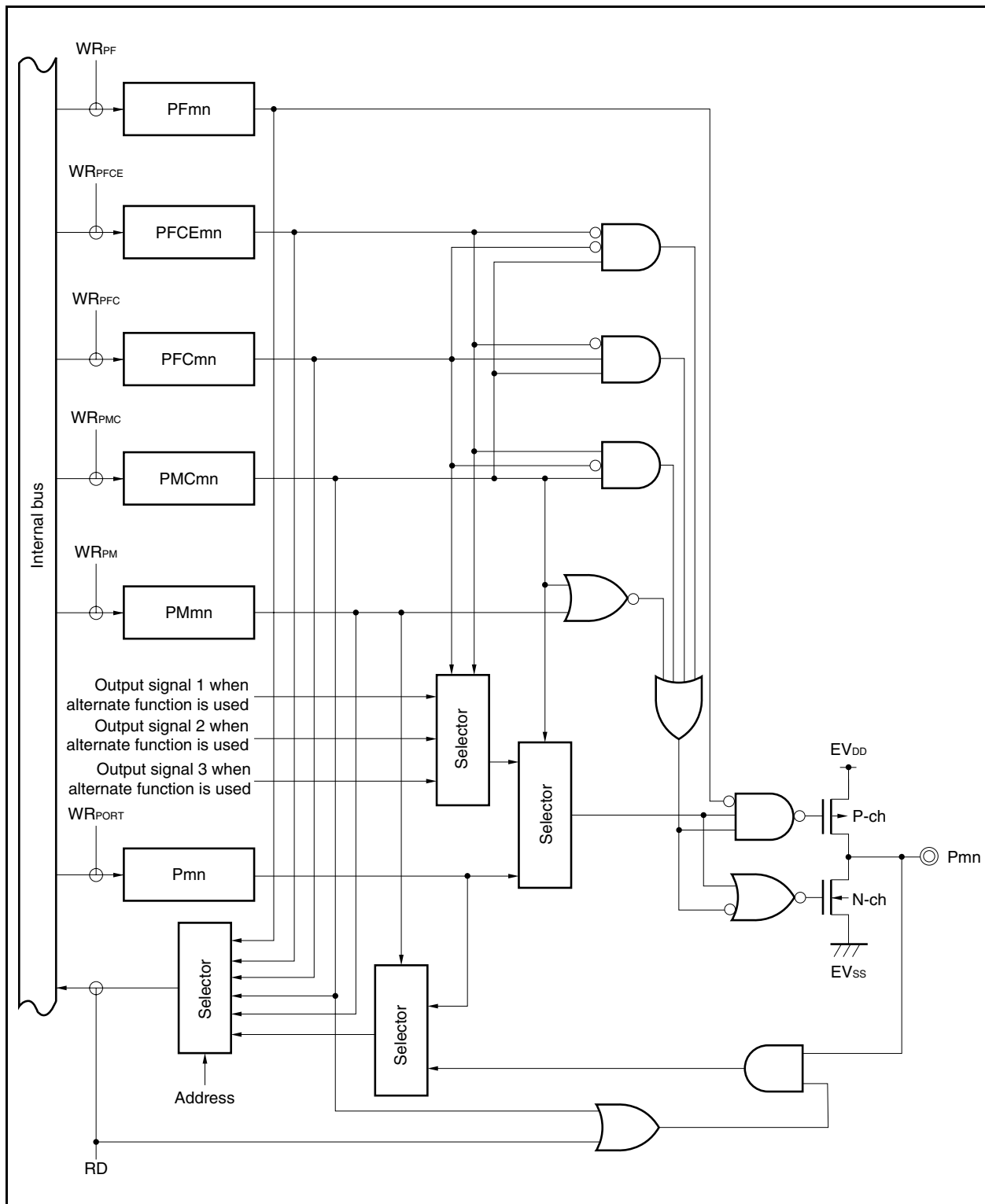

Figure 4-51. Block Diagram of Type U-23

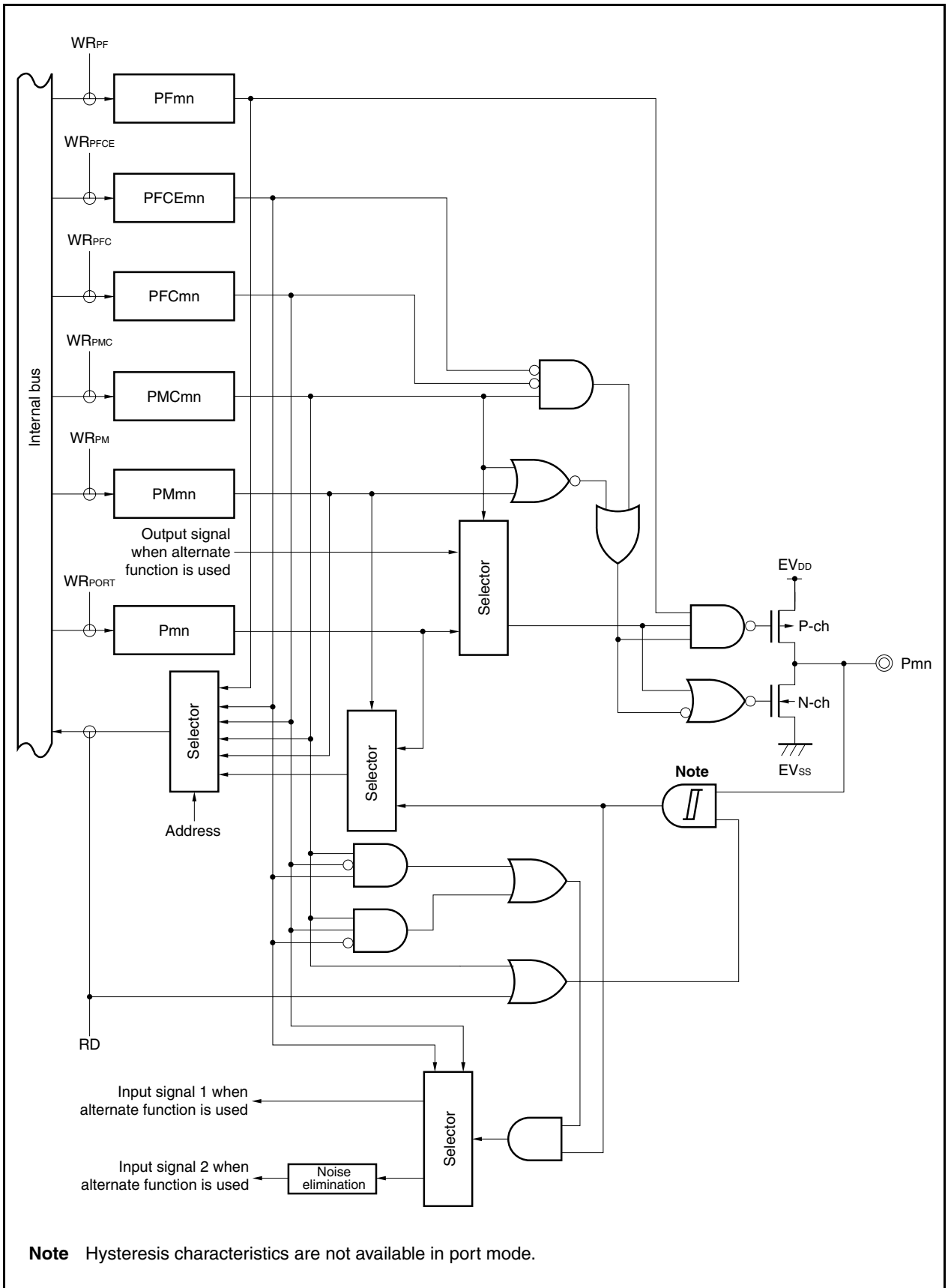

Figure 4-52. Block Diagram of Type U-24

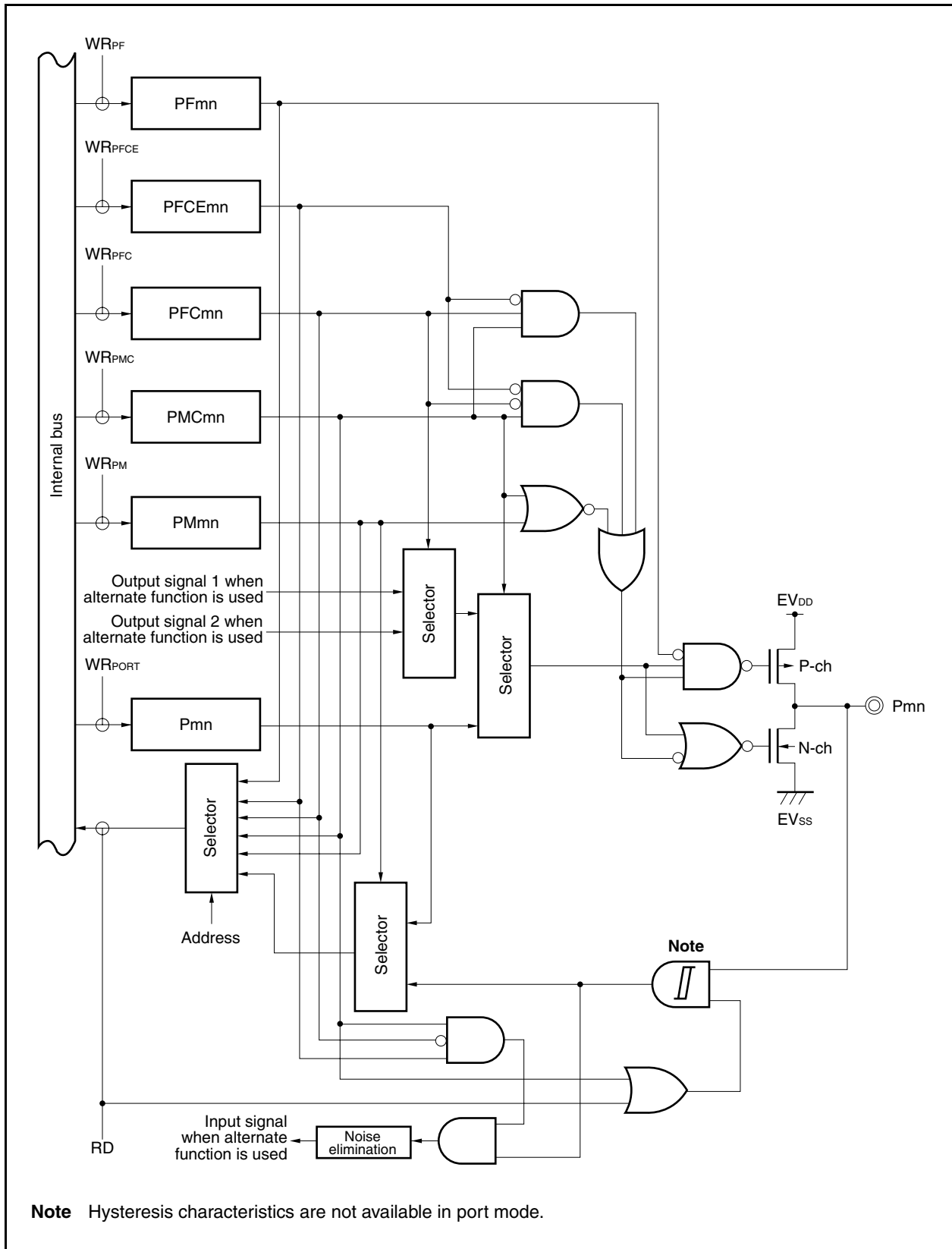
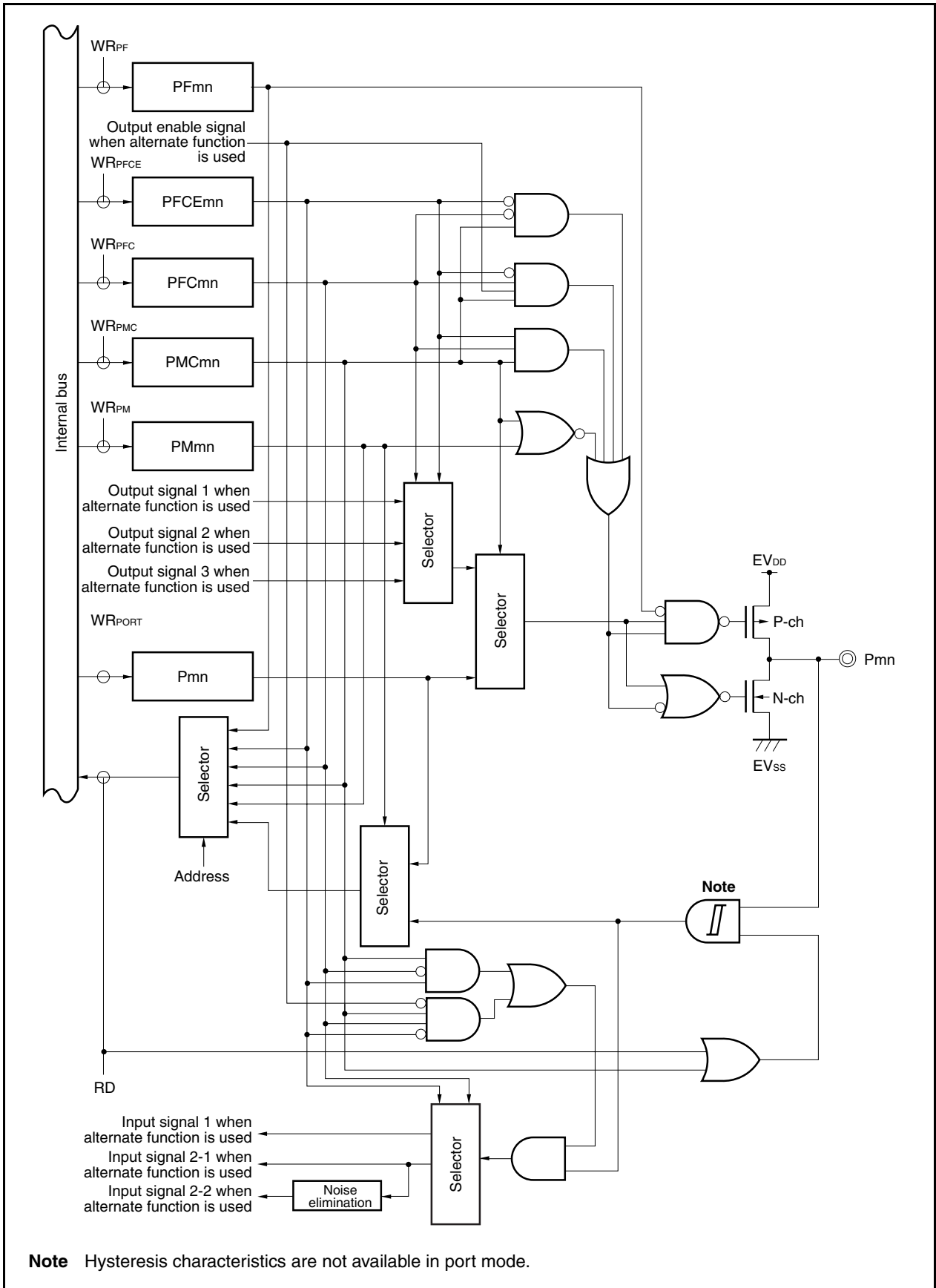

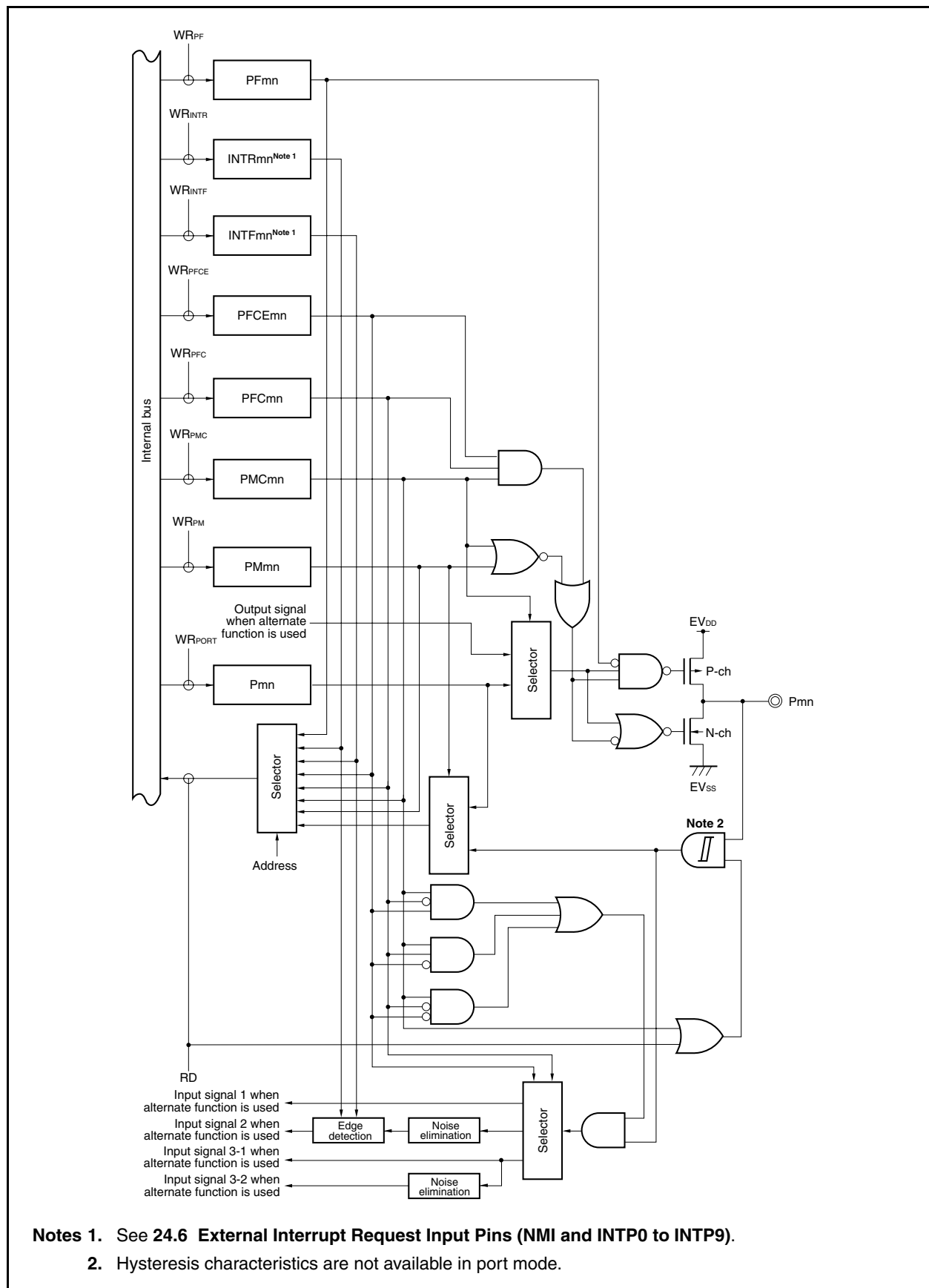

Figure 4-53. Block Diagram of Type U-25



**Note** Hysteresis characteristics are not available in port mode.

Figure 4-54. Block Diagram of Type U-26



<R>

Figure 4-55. Block Diagram of Type U-27

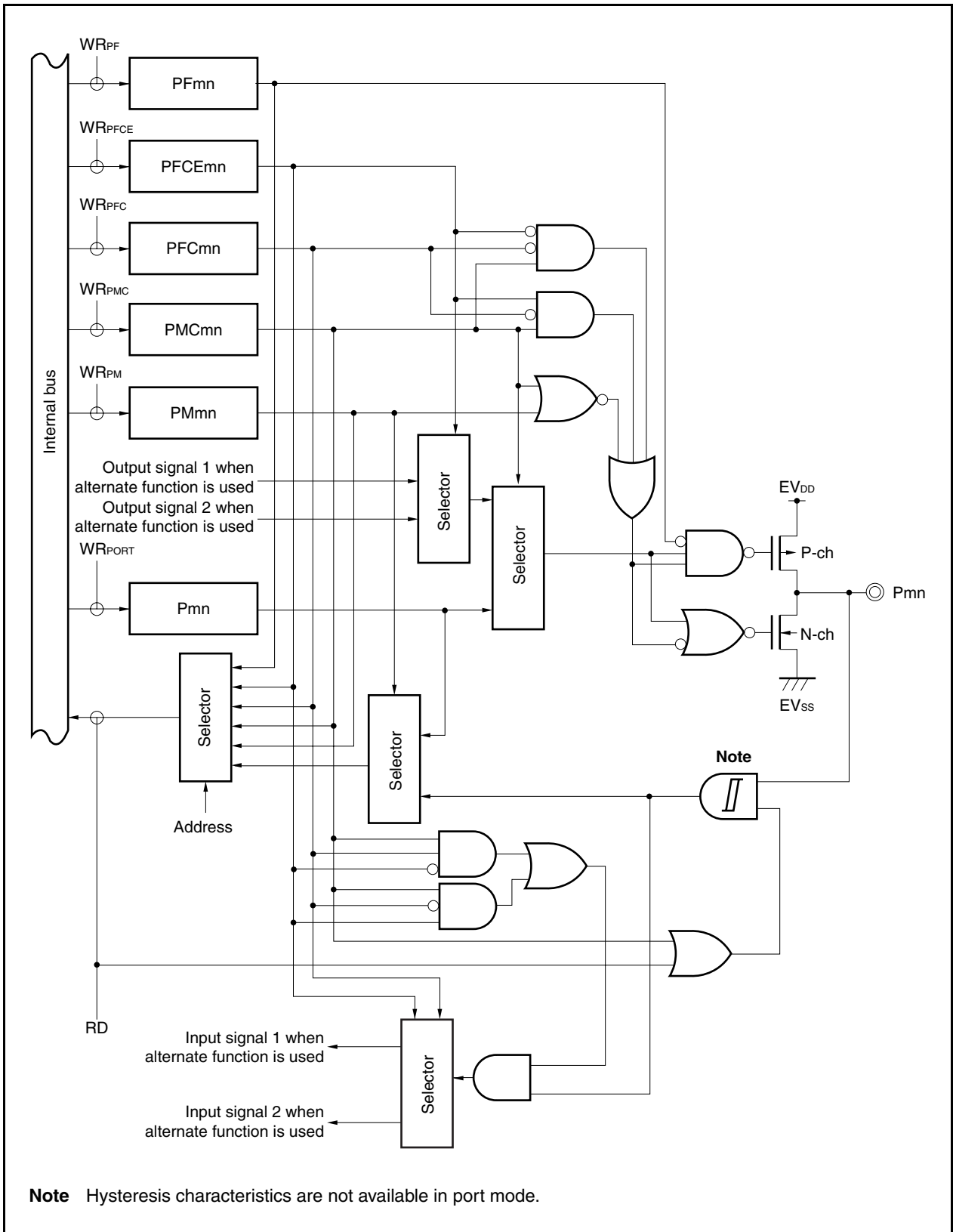
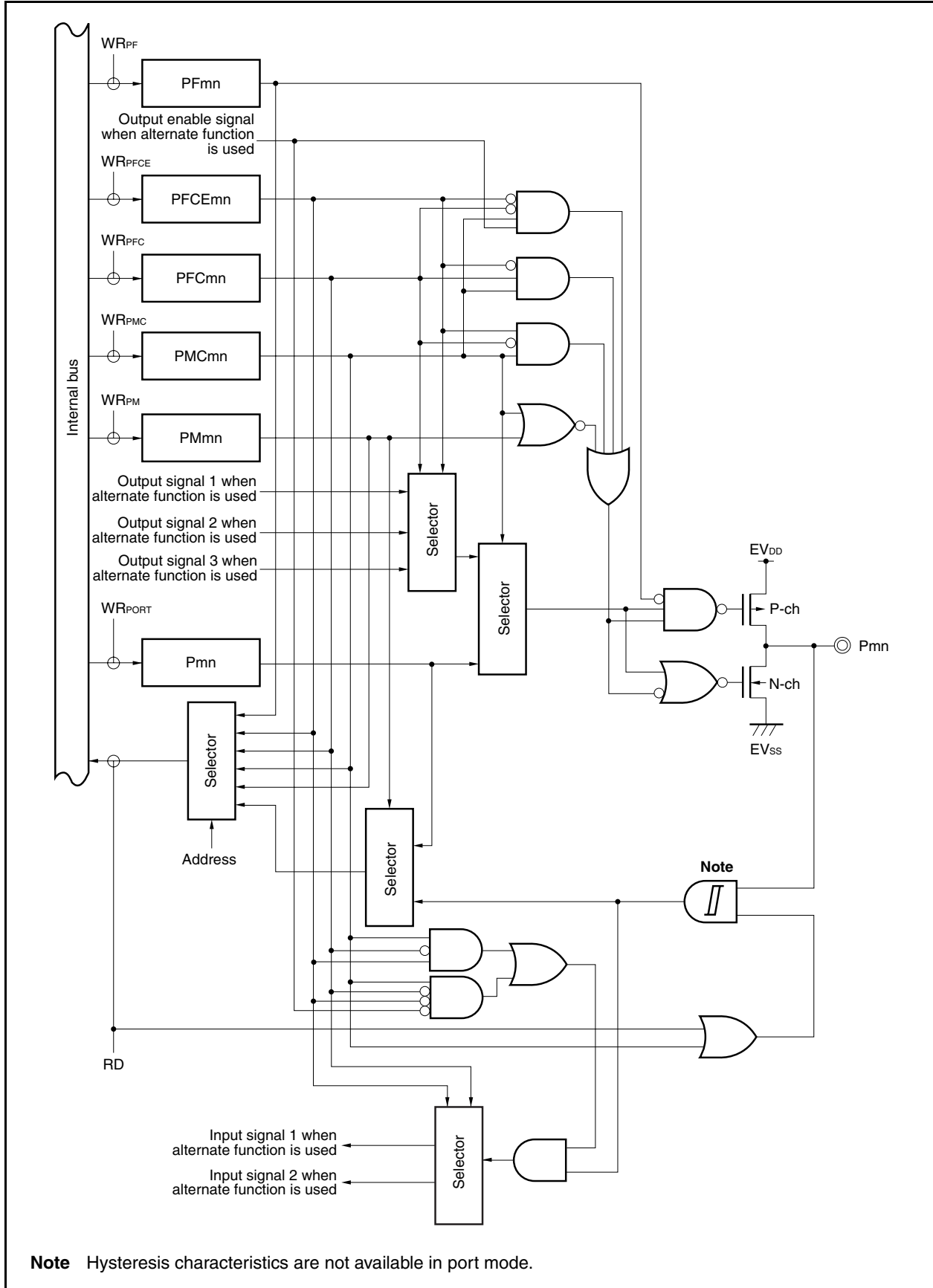

Figure 4-56. Block Diagram of Type U-28



**Note** Hysteresis characteristics are not available in port mode.

Figure 4-57. Block Diagram of Type U-29

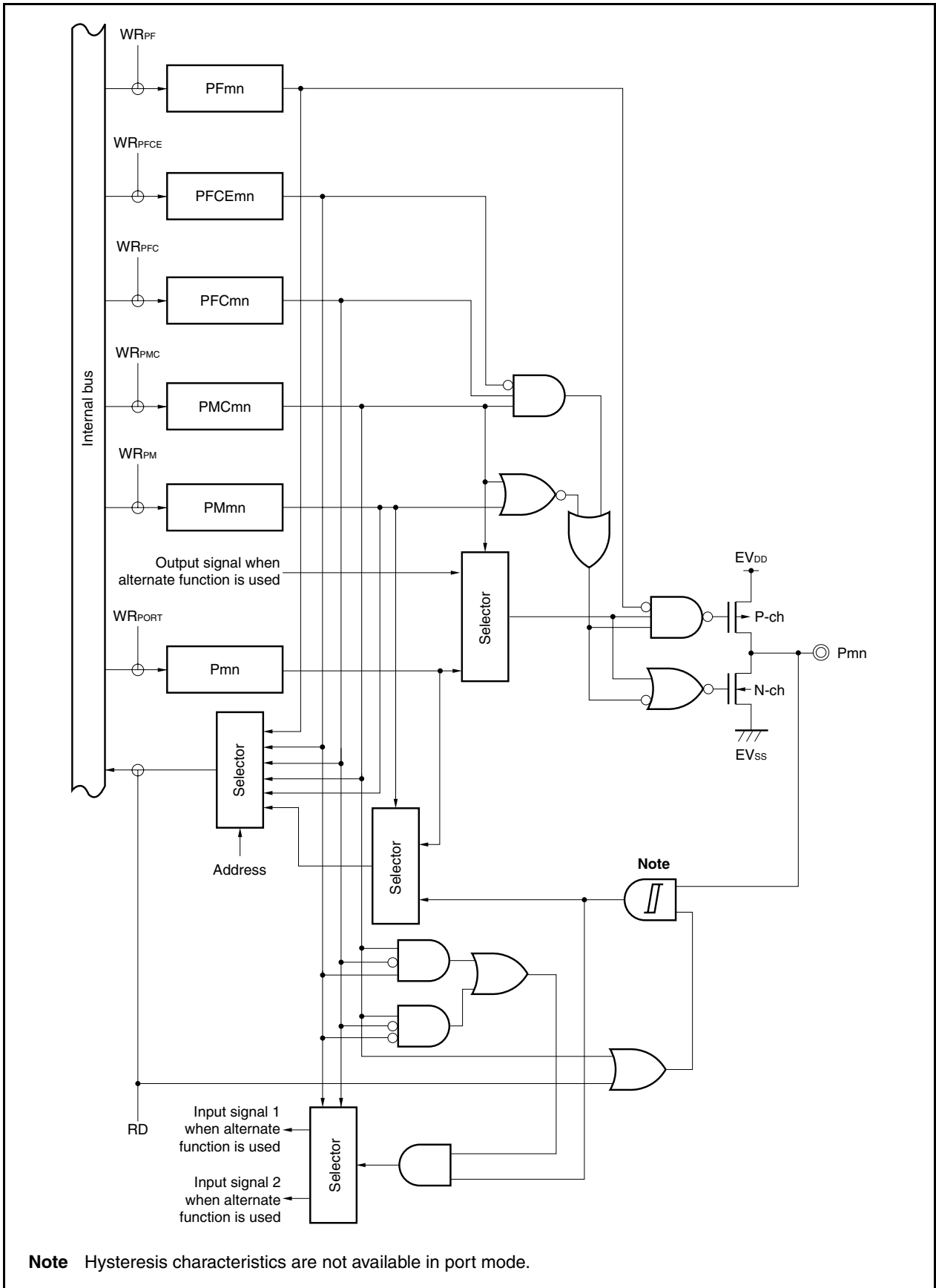

Figure 4-58. Block Diagram of Type U-30

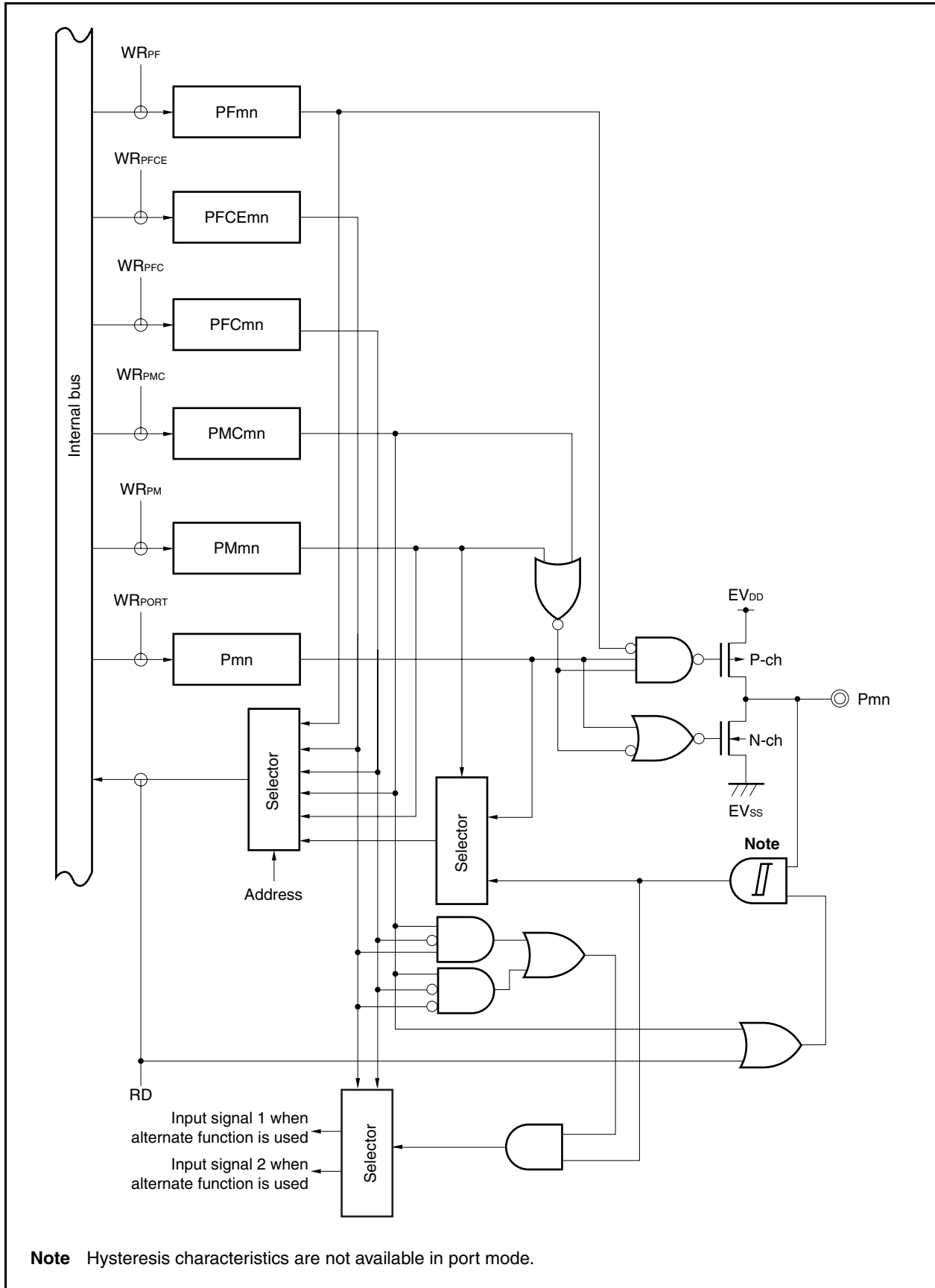

Figure 4-59. Block Diagram of Type U-31

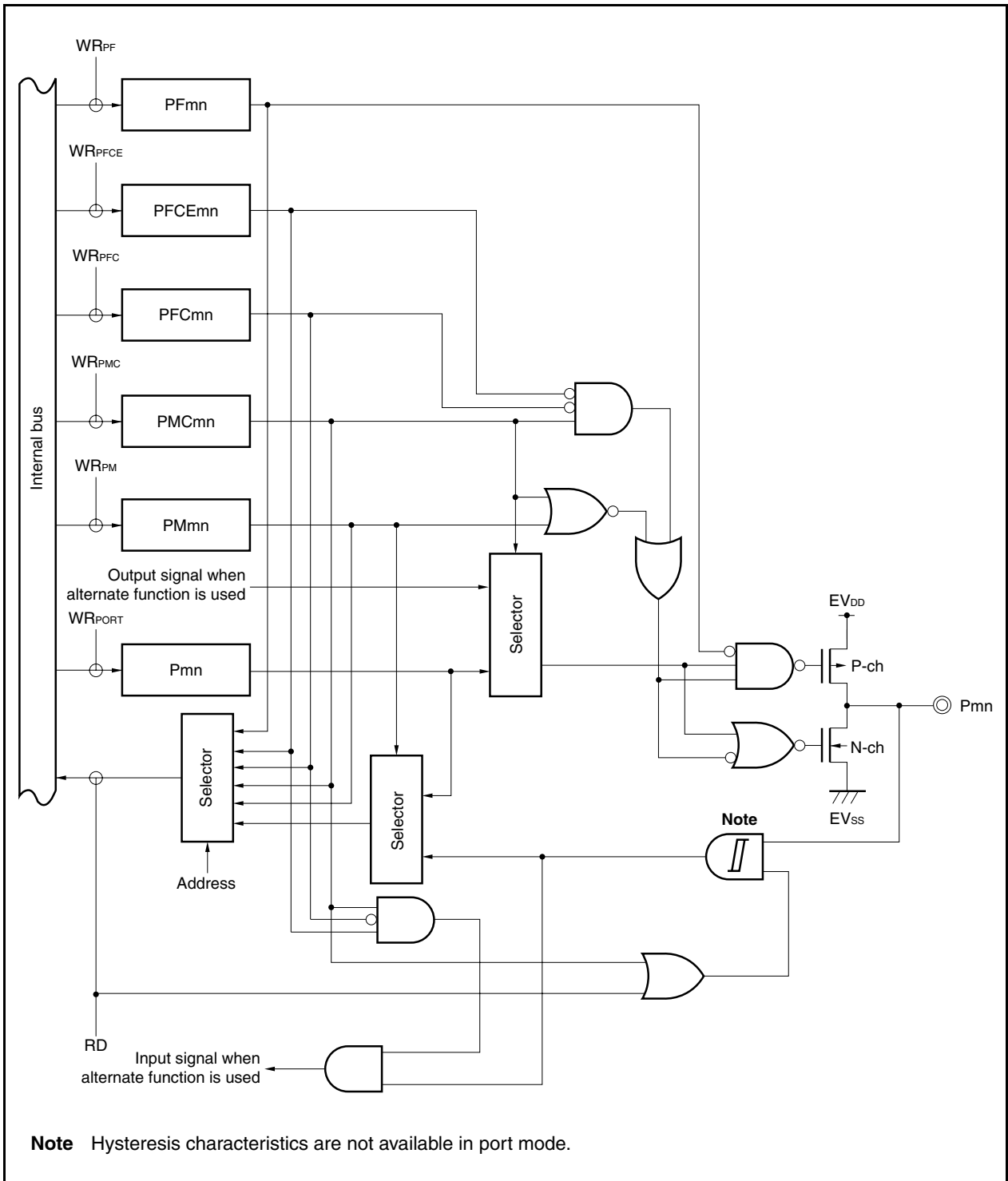

Figure 4-60. Block Diagram of Type U-32

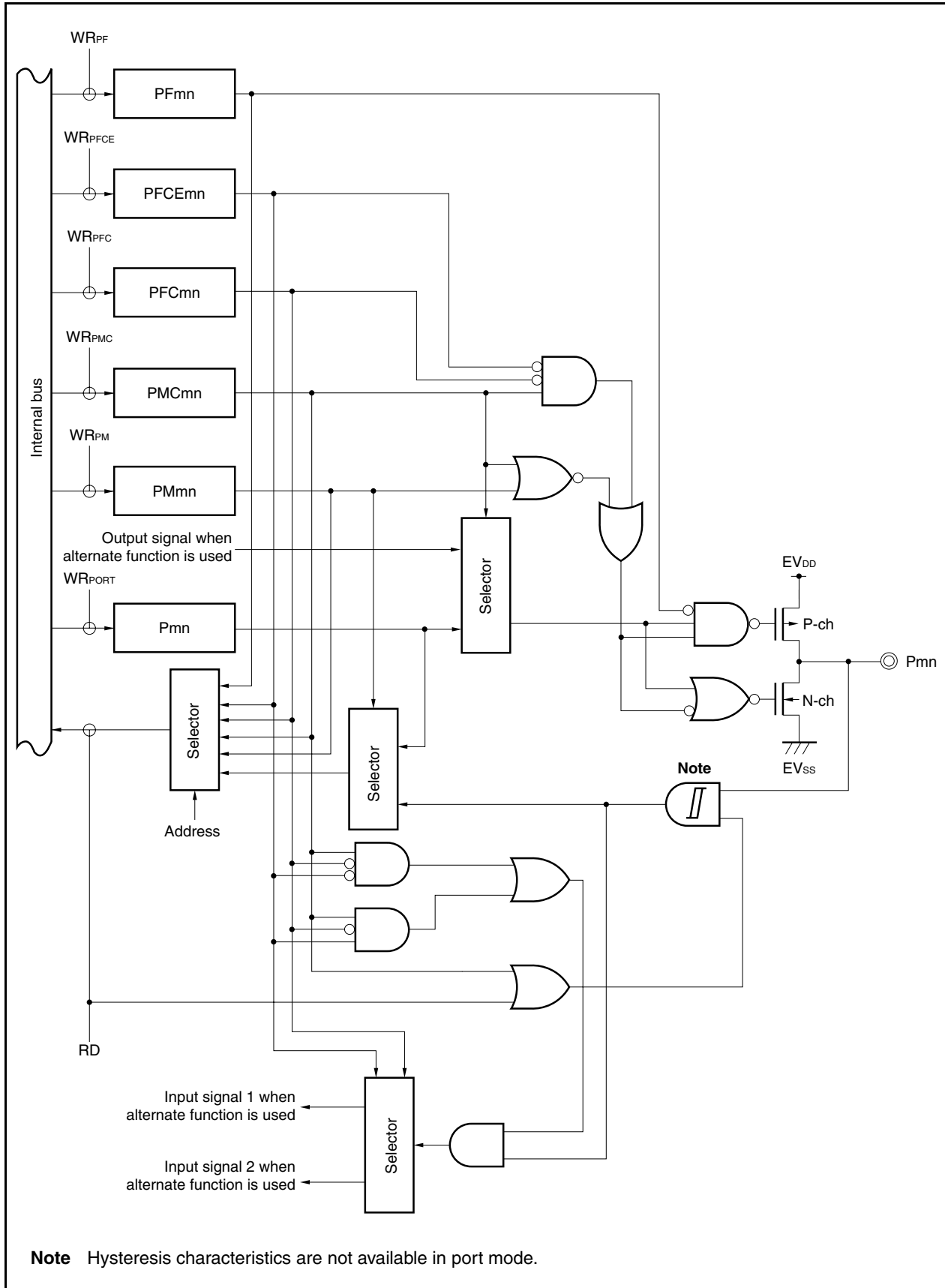
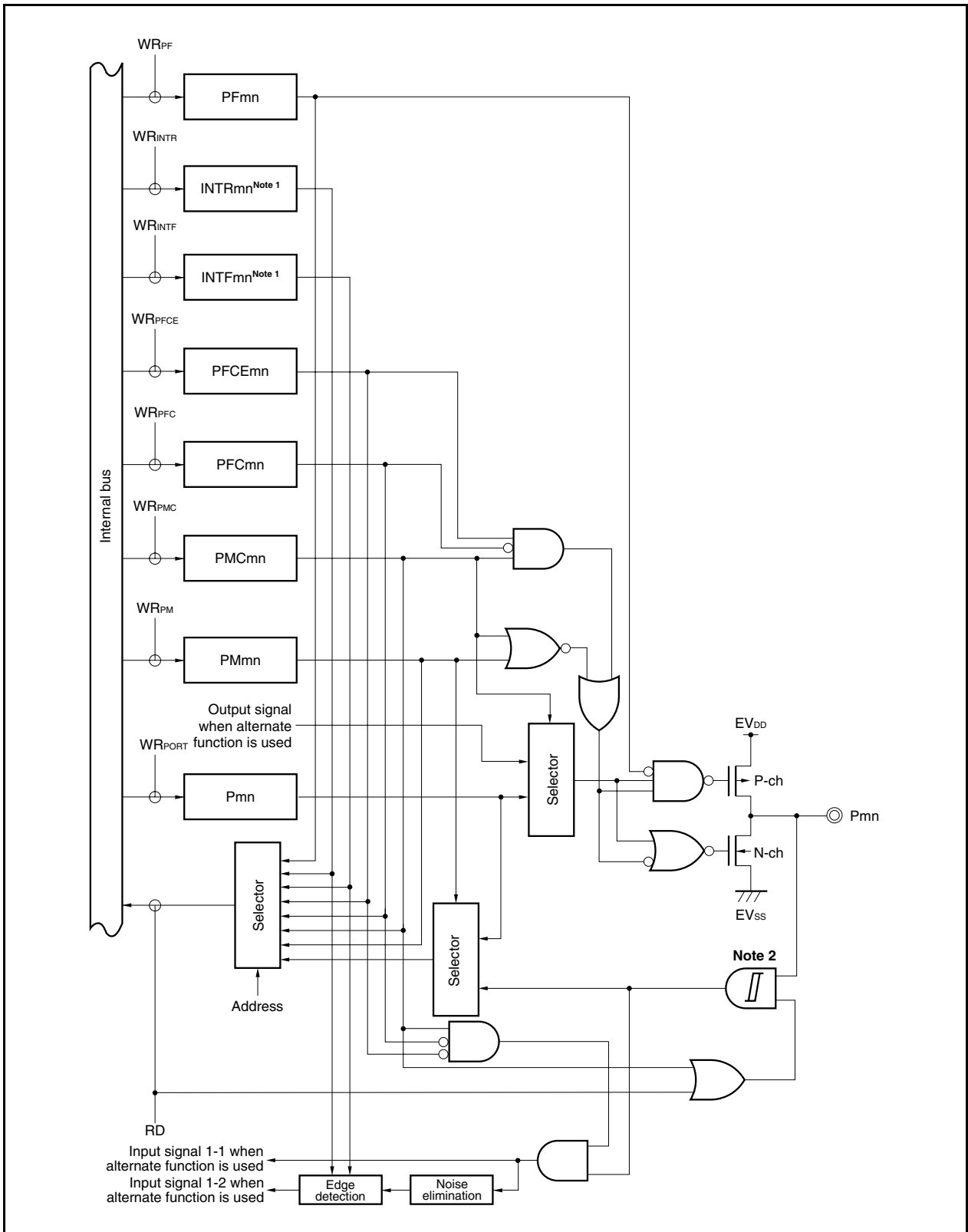



Figure 4-61. Block Diagram of Type U-33



**Notes 1.** See 24.6 External Interrupt Request Input Pins (NMI and INTP0 to INTP9).

**2.** Hysteresis characteristics are not available in port mode.

Figure 4-62. Block Diagram of Type U-34

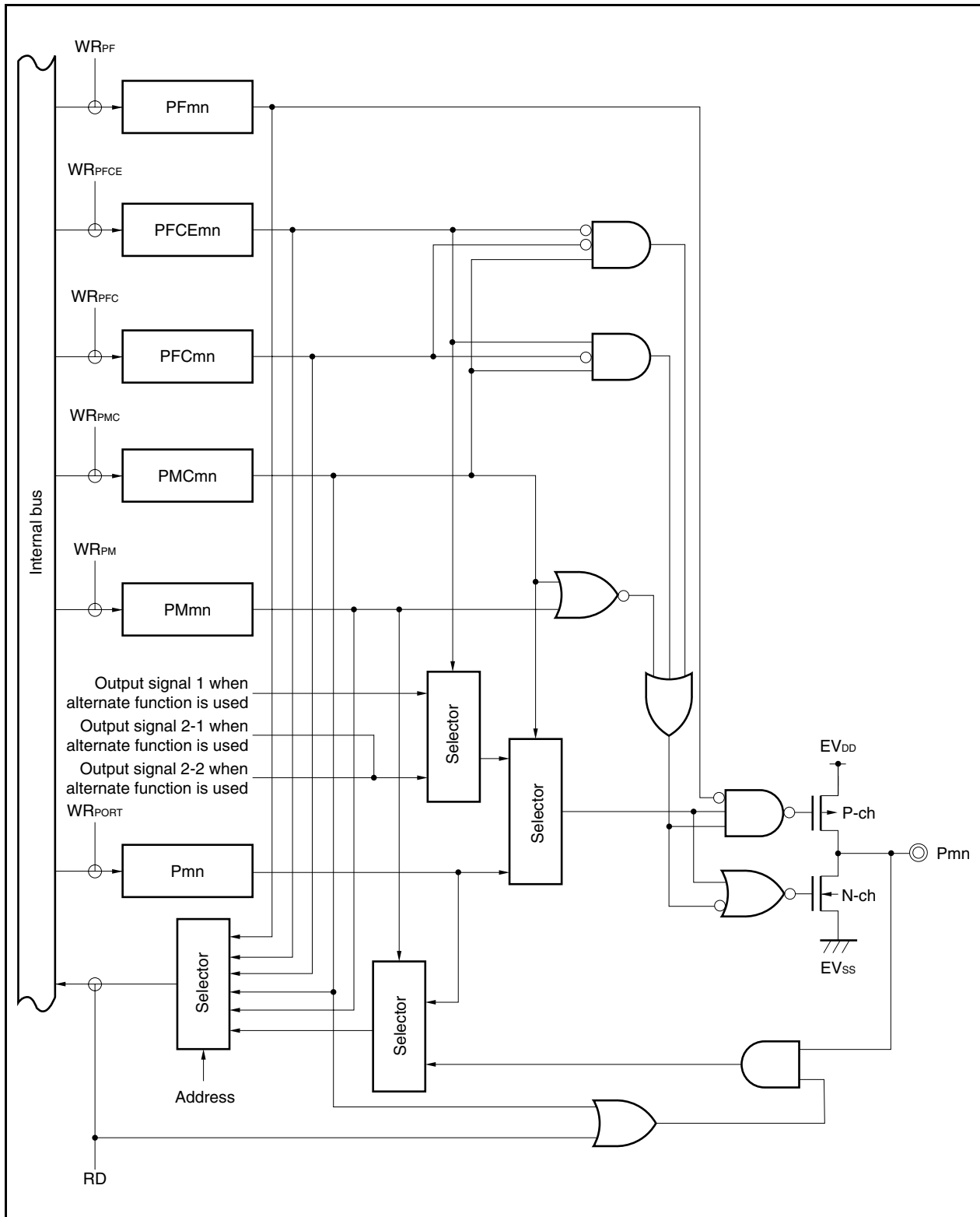

<R>

Figure 4-63. Block Diagram of Type U-35

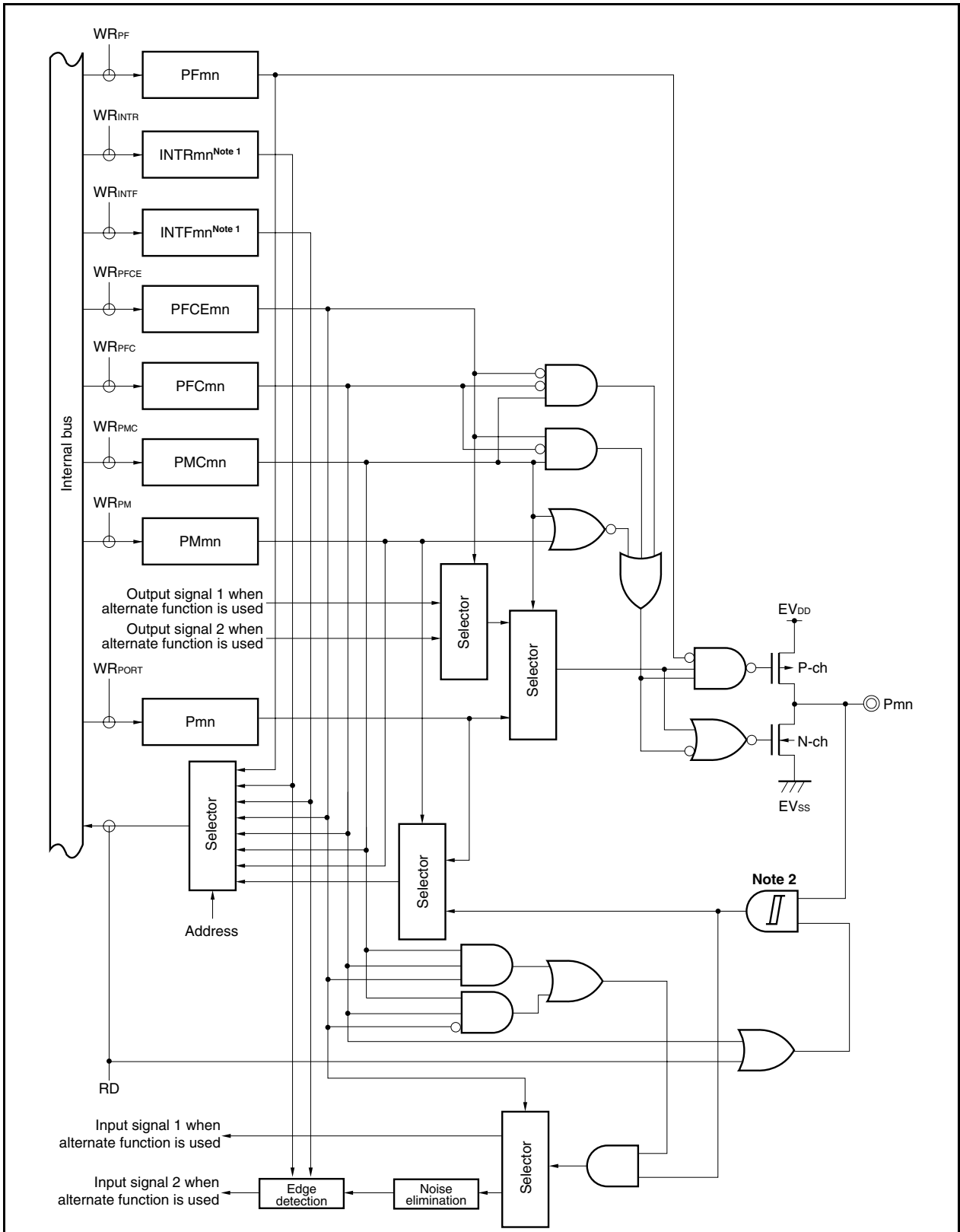

Notes 1. See 24.6 External Interrupt Request Input Pins (NMI and INTP0 to INTP9).

2. Hysteresis characteristics are not available in port mode.

<R>

Figure 4-64. Block Diagram of Type U-36

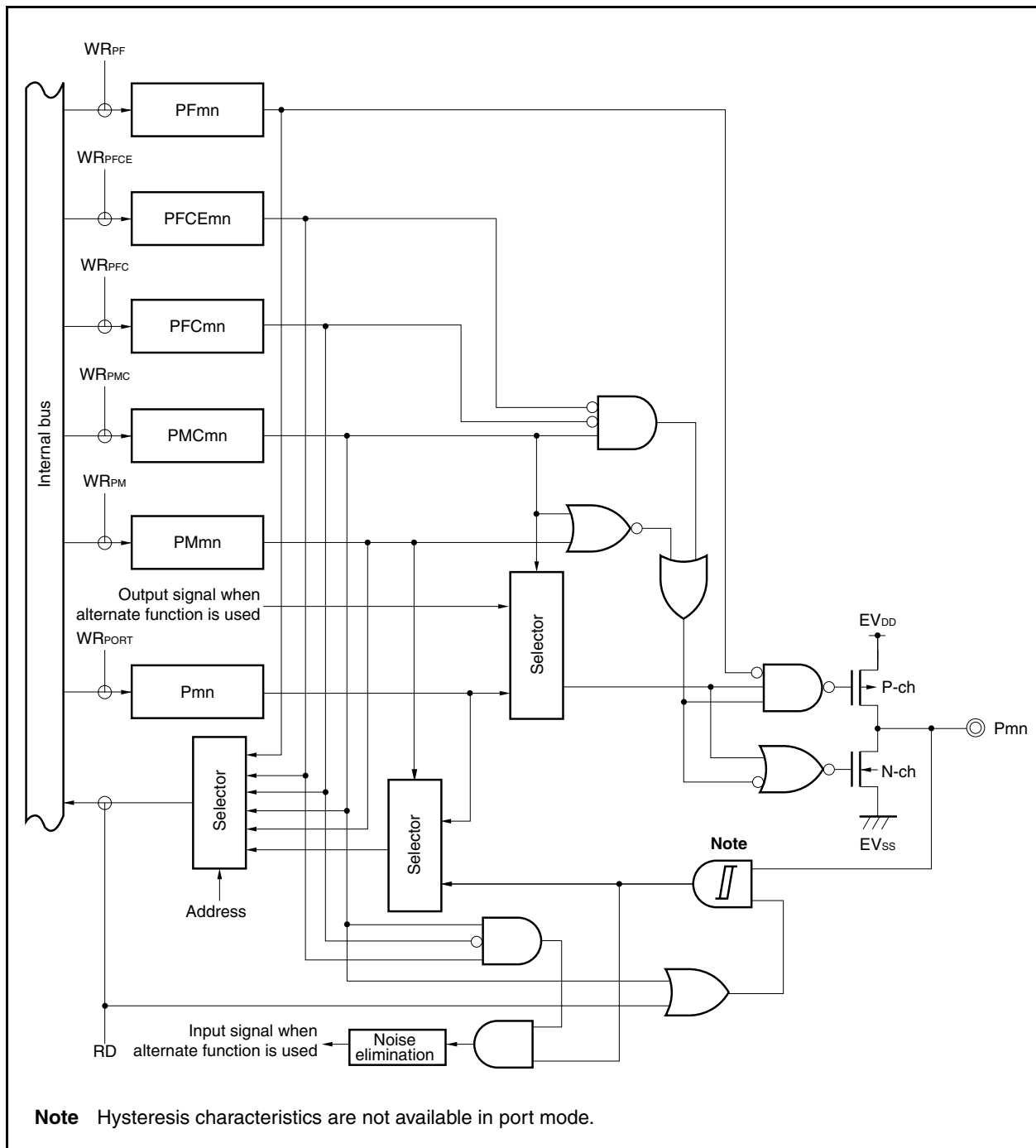

<R>

Figure 4-65. Block Diagram of Type U-37

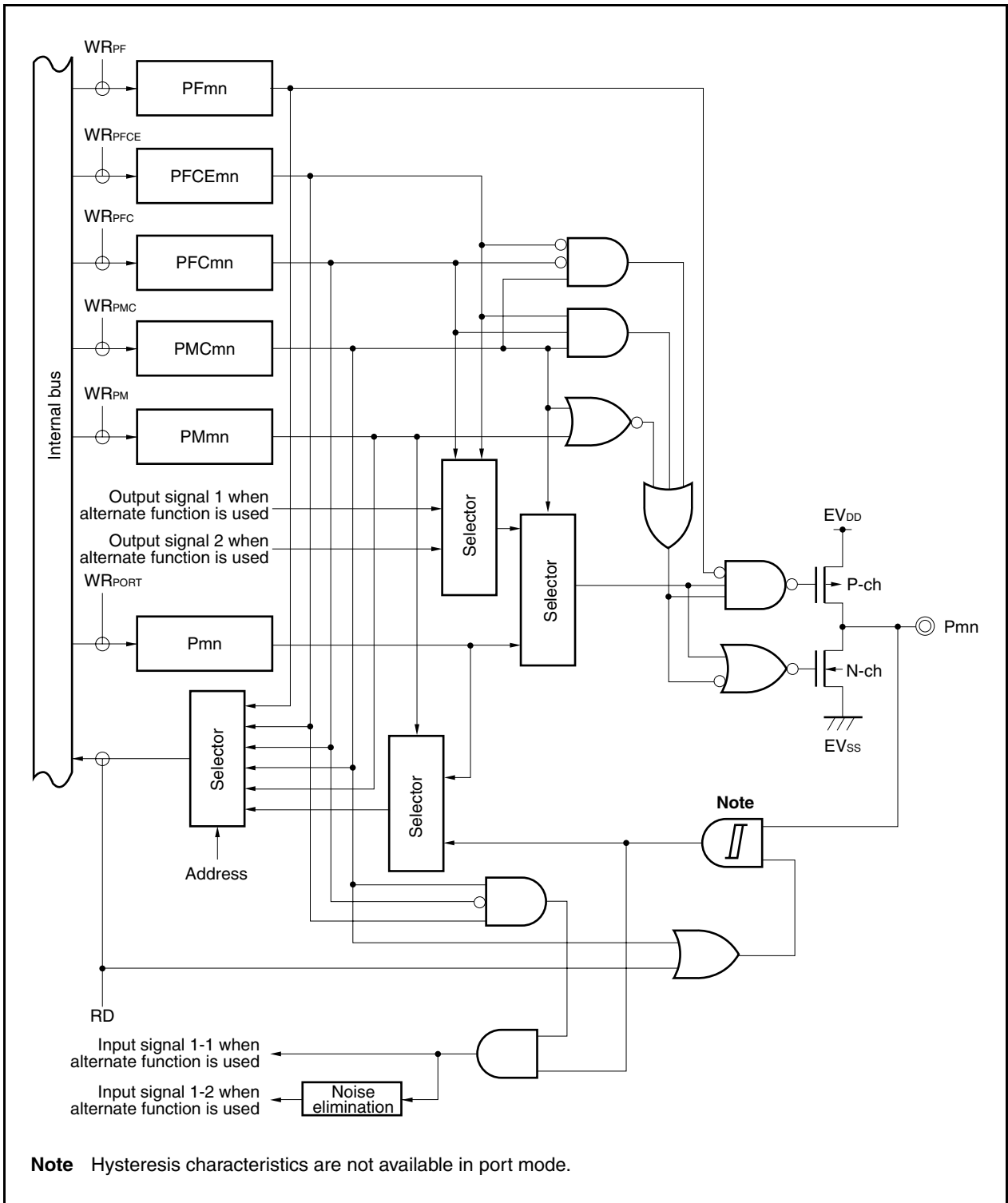

<R>

Figure 4-66. Block Diagram of Type U-38

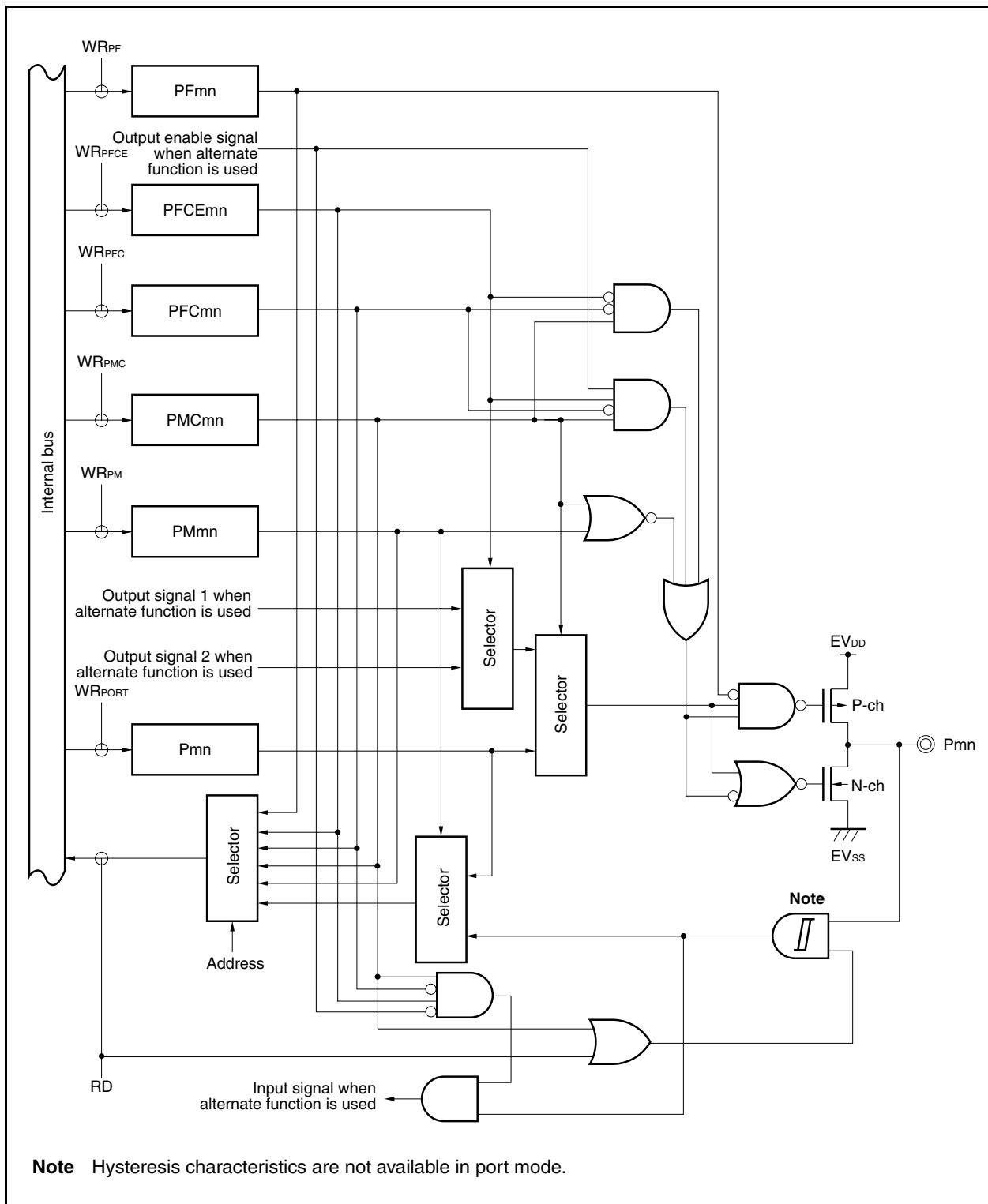
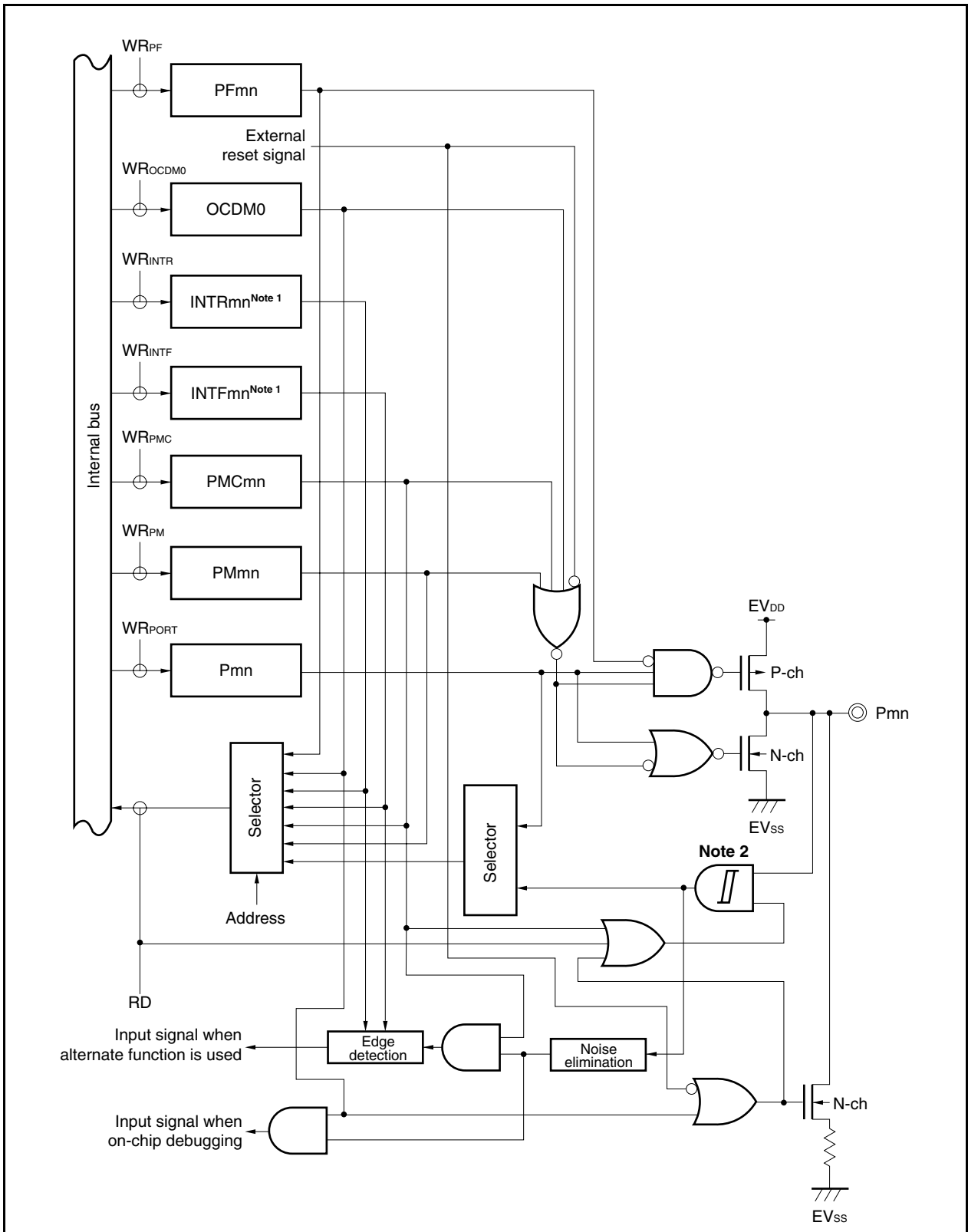

Figure 4-67. Block Diagram of Type AA-1



- Notes 1.** See 24.6 External Interrupt Request Input Pins (NMI and INTP0 to INTP9).  
**2.** Hysteresis characteristics are not available in port mode.

#### 4.5 Port Register Settings When Alternate Function Is Used

Table 4-25 shows the port register settings when each port is used for an alternate function. When using a port pin as an alternate-function pin, refer to the description of each pin.



&lt;R&gt; Table 4-25. Using Port Pin as Alternate-Function Pin (1/13)

Pin Name	Alternate Function		Pnx Bit of Pn Register	PMnx Bit of PMn Register	PMCnx Bit of PMCn Register	PFCEnx Bit of PFCEn Register	PFCnx Bit of PFCn Register	Other Bits (Registers)
	Name	I/O						
P00	TIP61	Input	P00 = Setting not required	PM00 = Setting not required	PMC00 = 1	PFCE00 = 0 <sup>Note 3</sup>	PFC00 = 0	
	TOP61	Output	P00 = Setting not required	PM00 = Setting not required	PMC00 = 1	PFCE00 = 0 <sup>Note 3</sup>	PFC00 = 1	
	SDA04 <sup>Note 2</sup>	I/O	P00 = Setting not required	PM00 = Setting not required	PMC00 = 1	PFCE00 = 1 <sup>Note 3</sup>	PFC00 = 0	PF00 (PF0) = 1
P01	TIP60	Input	P01 = Setting not required	PM01 = Setting not required	PMC01 = 1	PFCE01 = 0 <sup>Note 3</sup>	PFC01 = 0	
	TOP60	Output	P01 = Setting not required	PM01 = Setting not required	PMC01 = 1	PFCE01 = 0 <sup>Note 3</sup>	PFC01 = 1	
	SCL04 <sup>Note 2</sup>	I/O	P01 = Setting not required	PM01 = Setting not required	PMC01 = 1	PFCE01 = 1	PFC01 = 0	PF01 (PF0) = 1
P02	NMI	Input	P02 = Setting not required	PM02 = Setting not required	PMC02 = 1	–	–	
P03	INTP0	Input	P03 = Setting not required	PM03 = Setting not required	PMC03 = 1	–	PFC03 = 0	
	ADTRG	Input	P03 = Setting not required	PM03 = Setting not required	PMC03 = 1	–	PFC03 = 1	
P04	INTP1	Input	P04 = Setting not required	PM04 = Setting not required	PMC04 = 1	–	–	
P05	INTP2	Input	P05 = Setting not required	PM05 = Setting not required	PMC05 = 1	–	–	
	$\overline{\text{DRST}}$	Input	P05 = Setting not required	PM05 = Setting not required	PMC05 = Setting not required	–	–	OCDM0 (OCDM) = 1
P06	INTP3	Input	P06 = Setting not required	PM06 = Setting not required	PMC06 = 1	–	–	
P10	ANO0	Output	P10 = Setting not required	PM10 = 1	–	–	–	
P11	ANO1	Output	P11 = Setting not required	PM11 = 1	–	–	–	
P20 <sup>Note 1</sup>	SDA04 <sup>Note 1</sup>	I/O	P20 = Setting not required	PM20 = Setting not required	PM20 = 1	–	–	PF20 (PF2) = 1
P21 <sup>Note 1</sup>	SCL04 <sup>Note 1</sup>	I/O	P21 = Setting not required	PM21 = Setting not required	PM21 = 1	–	–	PF21 (PF2) = 1
P30	TXDA0	Output	P30 = Setting not required	PM30 = Setting not required	PMC30 = 1	–	PFC30 = 0	
	SOB4	Output	P30 = Setting not required	PM30 = Setting not required	PMC30 = 1	–	PFC30 = 1	

**Notes 1.** Valid for the V850E/SK3-H only.

**2.** The SDA04 and SCL04 pins are not included in the  $\mu$ PD70F3931 (V850E/SJ3-H), 70F3932 (V850E/SJ3-H), and 70F3933 (V850E/SJ3-H).

**3.** This setting is valid in products other than the  $\mu$ PD70F3931 (V850E/SJ3-H), 70F3932 (V850E/SJ3-H), and 70F3933 (V850E/SJ3-H).

This setting cannot be specified in the  $\mu$ PD70F3931 (V850E/SJ3-H), 70F3932 (V850E/SJ3-H), and 70F3933 (V850E/SJ3-H).

**Caution** Between the P10 and P11 pins, when one pin is used as the I/O port, and the other pin is used as the D/A output pin (ANO0, ANO1), make sure that the port I/O level does not change during D/A output.

Table 4-25. Using Port Pin as Alternate-Function Pin (2/13)

Pin Name	Alternate Function		Pnx Bit of Pn Register	PMnx Bit of PMn Register	PMCnx Bit of PMCn Register	PFCEnx Bit of PFCEn Register	PFCnx Bit of PFCn Register	Other Bits (Registers)
	Name	I/O						
P31	RXDA0	Input	P31 = Setting not required	PM31 = Setting not required	PMC31 = 1	–	<b>Note 3</b> , PFC31 = 0	
	INTP7	Input	P31 = Setting not required	PM31 = Setting not required	PMC31 = 1	–	<b>Note 3</b> , PFC31 = 0	
	SIB4	Input	P31 = Setting not required	PM31 = Setting not required	PMC31 = 1	–	PFC31 = 1	
P32	ASCKA0	Input	P32 = Setting not required	PM32 = Setting not required	PMC32 = 1	PFCE32 = 0	PFC32 = 0	
	SCKB4	I/O	P32 = Setting not required	PM32 = Setting not required	PMC32 = 1	PFCE32 = 0	PFC32 = 1	
	TIP00	Input	P32 = Setting not required	PM32 = Setting not required	PMC32 = 1	PFCE32 = 1	PFC32 = 0	
	TOP00	Output	P32 = Setting not required	PM32 = Setting not required	PMC32 = 1	PFCE32 = 1	PFC32 = 1	
P33	TIP01	Input	P33 = Setting not required	PM33 = Setting not required	PMC33 = 1	PFCE33 = 0	PFC33 = 0	
	TOP01	Output	P33 = Setting not required	PM33 = Setting not required	PMC33 = 1	PFCE33 = 0	PFC33 = 1	
	CTXD1 <sup>Note 1</sup>	Output	P33 = Setting not required	PM33 = Setting not required	PMC33 = 1	PFCE33 = 1	PFC33 = 0	
P34	TIP10	Input	P34 = Setting not required	PM34 = Setting not required	PMC34 = 1	PFCE34 = 0	PFC34 = 0	
	TOP10	Output	P34 = Setting not required	PM34 = Setting not required	PMC34 = 1	PFCE34 = 0	PFC34 = 1	
	CRXD1 <sup>Note 1</sup>	Input	P34 = Setting not required	PM34 = Setting not required	PMC34 = 1	PFCE34 = 1	PFC34 = 0	
P35	TIP11	Input	P35 = Setting not required	PM35 = Setting not required	PMC35 = 1	–	PFC35 = 0	
	TOP11	Output	P35 = Setting not required	PM35 = Setting not required	PMC35 = 1	–	PFC35 = 1	
P36	CTXD0 <sup>Note 2</sup>	Output	P36 = Setting not required	PM36 = Setting not required	PMC36 = 1	–	PFC36 = 0	
	IETX0	Output	P36 = Setting not required	PM36 = Setting not required	PMC36 = 1	–	PFC36 = 1	
P37	CRXD0 <sup>Note 2</sup>	Input	P37 = Setting not required	PM37 = Setting not required	PMC37 = 1	–	PFC37 = 0	
	IERX0	Input	P37 = Setting not required	PM37 = Setting not required	PMC37 = 1	–	PFC37 = 1	
P38	TXDA2	Output	P38 = Setting not required	PM38 = Setting not required	PMC38 = 1	PFCE38 = 0	PFC38 = 0	
	SDA00	I/O	P38 = Setting not required	PM38 = Setting not required	PMC38 = 1	PFCE38 = 0	PFC38 = 1	PF38 (PF3) = 1
	SIB2	Input	P38 = Setting not required	PM38 = Setting not required	PMC38 = 1	PFCE38 = 1	PFC38 = 0	

**Notes 1.** CAN controller (2-channel) version only

**2.** CAN controller version only

**3.** The INTP7 pin and RXDA0 pin are alternate-function pins. When using the pin as the RXDA0 pin, disable edge detection for the INTP7 alternate-function pin. (Clear the INTF3.INTF31 bit and the INRT3.INTR31 bit to 0.) When using the pin as the INTP7 pin, stop UARTA0 reception. (Clear the UA0CTL0.UA0RXE bit to 0.)

Table 4-25. Using Port Pin as Alternate-Function Pin (3/13)

Pin Name	Alternate Function		Pnx Bit of Pn Register	PMnx Bit of PMn Register	PMCnx Bit of PMCn Register	PFCEnx Bit of PFCEn Register	PFCnx Bit of PFCn Register	Other Bits (Registers)
	Name	I/O						
P39	RXDA2	Input	P39 = Setting not required	PM39 = Setting not required	PMC39 = 1	PFCE39 = 0	PFC39 = 0	
	SCL00	I/O	P39 = Setting not required	PM39 = Setting not required	PMC39 = 1	PFCE39 = 0	PFC39 = 1	PF39 (PF3) = 1
	SCKB2	I/O	P39 = Setting not required	PM39 = Setting not required	PMC39 = 1	PFCE39 = 1	PFC39 = 0	
P310 <sup>Note</sup>	SOB2 <sup>Note</sup>	Output	P310 = Setting not required	PM310 = Setting not required	PMC310 = 1	PFCE310 = 1	PFC310 = 0	
P311 <sup>Note</sup>	TXDA2 <sup>Note</sup>	Output	P311 = Setting not required	PM311 = Setting not required	PMC311 = 1	–	–	
P312 <sup>Note</sup>	RXDA2 <sup>Note</sup>	Input	P312 = Setting not required	PM312 = Setting not required	PMC312 = 1	–	–	
P40	SIB0	Input	P40 = Setting not required	PM40 = Setting not required	PMC40 = 1	–	PFC40 = 0	
	SDA01	I/O	P40 = Setting not required	PM40 = Setting not required	PMC40 = 1	–	PFC40 = 1	PF40 (PF4) = 1
P41	SOB0	Output	P41 = Setting not required	PM41 = Setting not required	PMC41 = 1	–	PFC41 = 0	
	SCL01	I/O	P41 = Setting not required	PM41 = Setting not required	PMC41 = 1	–	PFC41 = 1	PF41 (PF4) = 1
P42	SCKB0	I/O	P42 = Setting not required	PM42 = Setting not required	PMC42 = 1	–	PFC42 = 0	
	INTP2	Input	P42 = Setting not required	PM42 = Setting not required	PMC42 = 1	–	PFC42 = 1	
P44 <sup>Note</sup>	IETX0 <sup>Note</sup>	Output	P44 = Setting not required	PM44 = Setting not required	PMC44 = 1	–	–	
P45 <sup>Note</sup>	IERY0 <sup>Note</sup>	Input	P45 = Setting not required	PM45 = Setting not required	PMC45 = 1	–	–	
P50	KR0	Input	P50 = Setting not required	PM50 = Setting not required	PMC50 = 1	PFCE50 = 0	PFC50 = 1	TQ0IS3, TQ0IS2 (TQ0IOC1) = 00
	TIQ01	Input	P50 = Setting not required	PM50 = Setting not required	PMC50 = 1	PFCE50 = 0	PFC50 = 1	KRM0 (KRM) = 0
	TOQ01	Output	P50 = Setting not required	PM50 = Setting not required	PMC50 = 1	PFCE50 = 1	PFC50 = 0	
	RTP00	Output	P50 = Setting not required	PM50 = Setting not required	PMC50 = 1	PFCE50 = 1	PFC50 = 1	
P51	INTP7	Input	P51 = Setting not required	PM51 = Setting not required	PMC51 = 1	PFCE51 = 0	PFC51 = 0	
	KR1	Input	P51 = Setting not required	PM51 = Setting not required	PMC51 = 1	PFCE51 = 0	PFC51 = 1	TQ0IS5, TQ0IS4 (TQ0IOC1) = 00
	TIQ02	Input	P51 = Setting not required	PM51 = Setting not required	PMC51 = 1	PFCE51 = 0	PFC51 = 1	KRM1 (KRM) = 0
	TOQ02	Output	P51 = Setting not required	PM51 = Setting not required	PMC51 = 1	PFCE51 = 1	PFC51 = 0	
	RTP01	Output	P51 = Setting not required	PM51 = Setting not required	PMC51 = 1	PFCE51 = 1	PFC51 = 1	

**Note** Valid for the V850E/SK3-H only.

Table 4-25. Using Port Pin as Alternate-Function Pin (4/13)

Pin Name	Alternate Function		Pnx Bit of Pn Register	PMnx Bit of PMn Register	PMCnx Bit of PMCn Register	PFCEnx Bit of PFCEn Register	PFCnx Bit of PFCn Register	Other Bits (Registers)
	Name	I/O						
P52	KR2	Input	P52 = Setting not required	PM52 = Setting not required	PMC52 = 1	PFCE52 = 0	PFC52 = 1	TQ0IS7, TQ0IS6 (TQ0IOC1) = 00
	TIQ03	Input	P52 = Setting not required	PM52 = Setting not required	PMC52 = 1	PFCE52 = 0	PFC52 = 1	KRM2 (KRM) = 0
	TOQ03	Output	P52 = Setting not required	PM52 = Setting not required	PMC52 = 1	PFCE52 = 1	PFC52 = 0	
	RTP02	Output	P52 = Setting not required	PM52 = Setting not required	PMC52 = 1	PFCE52 = 1	PFC52 = 1	
	DDI	Input	P52 = Setting not required	PM52 = Setting not required	PMC52 = Setting not required	PFCE52 = Setting not required	PFC52 = Setting not required	OCDM0 (OCDM) = 1
P53	SIB2	Input	P53 = Setting not required	PM53 = Setting not required	PMC53 = 1	PFCE53 = 0	PFC53 = 0	
	KR3	Input	P53 = Setting not required	PM53 = Setting not required	PMC53 = 1	PFCE53 = 0	PFC53 = 1	TQ0IS1, TQ0IS0 (TQ0IOC1) = 00, TQ0EES1, TQ0EES0 (TQ0IOC2) = 00, TQ0ETS1, TQ0ETS0 (TQ0IOC2) = 00
	TIQ00	Input	P53 = Setting not required	PM53 = Setting not required	PMC53 = 1	PFCE53 = 0	PFC53 = 1	KRM3 (KRM) = 0
	TOQ00	Input	P53 = Setting not required	PM53 = Setting not required	PMC53 = 1	PFCE53 = 1	PFC53 = 0	
	RTP03	Output	P53 = Setting not required	PM53 = Setting not required	PMC53 = 1	PFCE53 = 1	PFC53 = 1	
	DDO	Output	P53 = Setting not required	PM53 = Setting not required	PMC53 = Setting not required	PFCE53 = Setting not required	PFC53 = Setting not required	OCDM0 (OCDM) = 1
P54	SOB2	Output	P54 = Setting not required	PM54 = Setting not required	PMC54 = 1	PFCE54 = 0	PFC54 = 0	
	KR4	Input	P54 = Setting not required	PM54 = Setting not required	PMC54 = 1	PFCE54 = 0	PFC54 = 1	
	RTP04	Output	P54 = Setting not required	PM54 = Setting not required	PMC54 = 1	PFCE54 = 1	PFC54 = 1	
	DCK	Input	P54 = Setting not required	PM54 = Setting not required	PMC54 = Setting not required	PFCE54 = Setting not required	PFC54 = Setting not required	OCDM0 (OCDM) = 1
P55	SCKB2	I/O	P55 = Setting not required	PM55 = Setting not required	PMC55 = 1	PFCE55 = 0	PFC55 = 0	
	KR5	Input	P55 = Setting not required	PM55 = Setting not required	PMC55 = 1	PFCE55 = 0	PFC55 = 1	
	RTP05	Output	P55 = Setting not required	PM55 = Setting not required	PMC55 = 1	PFCE55 = 1	PFC55 = 1	
	DMS	Input	P55 = Setting not required	PM55 = Setting not required	PMC55 = Setting not required	PFCE55 = Setting not required	PFC55 = Setting not required	OCDM0 (OCDM) = 1
P56 <sup>Note</sup>	RXDA4 <sup>Note</sup>	Input	P56 = Setting not required	PM56 = Setting not required	PMC56 = 1	–	–	
P57 <sup>Note</sup>	TXDA4 <sup>Note</sup>	Output	P57 = Setting not required	PM57 = Setting not required	PMC57 = 1	–	–	

**Note** Valid for the V850E/SK3-H only.

&lt;R&gt; Table 4-25. Using Port Pin as Alternate-Function Pin (5/13)

Pin Name	Alternate Function		Pnx Bit of Pn Register	PMnx Bit of PMn Register	PMCnx Bit of PMCn Register	PFCEnx Bit of PFCEn Register	PFCnx Bit of PFCn Register	Other Bits (Registers)
	Name	I/O						
P60	RTP10	Output	P60 = Setting not required	PM60 = Setting not required	PMC60 = 1	PFCE60 = 0 <sup>Note 2</sup>	PFC60 = 0	
	RXDA4	Input	P60 = Setting not required	PM60 = Setting not required	PMC60 = 1	PFCE60 = 0 <sup>Note 2</sup>	PFC60 = 1	
	SIE0 <sup>Note 1</sup>	Input	P60 = Setting not required	PM60 = Setting not required	PMC60 = 1	PFCE60 = 1 <sup>Note 2</sup>	PFC60 = 0	
P61	RTP11	Output	P61 = Setting not required	PM61 = Setting not required	PMC61 = 1	PFCE61 = 0 <sup>Note 2</sup>	PFC61 = 0	
	TXDA4	Output	P61 = Setting not required	PM61 = Setting not required	PMC61 = 1	PFCE61 = 0 <sup>Note 2</sup>	PFC61 = 1	
	SOE0 <sup>Note 1</sup>	Output	P61 = Setting not required	PM61 = Setting not required	PMC61 = 1	PFCE61 = 1 <sup>Note 2</sup>	PFC61 = 0 <sup>Note 2</sup>	
P62	RTP12	Output	P62 = Setting not required	PM62 = Setting not required	PMC62 = 1	PFCE62 = 0 <sup>Note 2</sup>	PFC62 = 0 <sup>Note 2</sup>	
	SCKE0 <sup>Note 1</sup>	I/O	P62 = Setting not required	PM62 = Setting not required	PMC62 = 1	PFCE62 = 1	PFC62 = 0	
P63	RTP13	Output	P63 = Setting not required	PM63 = Setting not required	PMC63 = 1	PFCE63 = 0	PFC63 = 0	
	SIE1 <sup>Note 1</sup>	Input	P63 = Setting not required	PM63 = Setting not required	PMC63 = 1	PFCE63 = 0	PFC63 = 1	
	KR4	Input	P63 = Setting not required	PM63 = Setting not required	PMC63 = 1	PFCE63 = 1	PFC63 = 0	
P64	RTP14	Output	P64 = Setting not required	PM64 = Setting not required	PMC64 = 1	PFCE64 = 0	PFC64 = 0	
	SOE1 <sup>Note 1</sup>	Output	P64 = Setting not required	PM64 = Setting not required	PMC64 = 1	PFCE64 = 0	PFC64 = 1	
	KR5	Input	P64 = Setting not required	PM64 = Setting not required	PMC64 = 1	PFCE64 = 1	PFC64 = 0	
P65	RTP15	Output	P65 = Setting not required	PM65 = Setting not required	PMC65 = 1	PFCE65 = 0	PFC65 = 0	
	SCKE1 <sup>Note 1</sup>	I/O <sup>Note 1</sup>	P65 = Setting not required	PM65 = Setting not required	PMC65 = 1	PFCE65 = 0	PFC65 = 1	
	KR2	Input	P65 = Setting not required	PM65 = Setting not required	PMC65 = 1	PFCE65 = 1	PFC65 = 0	TQ0IS7, TQ0IS6 (TQ0I0C1) = 00
	TIQ03	Input	P65 = Setting not required	PM65 = Setting not required	PMC65 = 1	PFCE65 = 1	PFC65 = 0	KRM2 (KRM) = 0
	TOQ03	Output	P65 = Setting not required	PM65 = Setting not required	PMC65 = 1	PFCE65 = 1	PFC65 = 1	

**Notes 1.** These pins are not included in the  $\mu$ PD70F3931 (V850E/SJ3-H), 70F3932 (V850E/SJ3-H), and 70F3933 (V850E/SJ3-H).

**2.** This setting is valid in products other than the  $\mu$ PD70F3931 (V850E/SJ3-H), 70F3932 (V850E/SJ3-H), and 70F3933 (V850E/SJ3-H).

This setting cannot be specified in the  $\mu$ PD70F3931 (V850E/SJ3-H), 70F3932 (V850E/SJ3-H), and 70F3933 (V850E/SJ3-H).

&lt;R&gt; Table 4-25. Using Port Pin as Alternate-Function Pin (6/13)

Pin Name	Alternate Function		Pnx Bit of Pn Register	PMnx Bit of PMn Register	PMCnx Bit of PMCn Register	PFCEnx Bit of PFCEn Register	PFCnx Bit of PFCn Register	Other Bits (Registers)
	Name	I/O						
P66	SIB5	Input	P66 = Setting not required	PM66 = Setting not required	PMC66 = 1	PFCE66 = 0	PFC66 = 0	
	INTP9	Input	P66 = Setting not required	PM66 = Setting not required	PMC66 = 1	PFCE66 = 0	PFC66 = 1	
	KR3	Input	P66 = Setting not required	PM66 = Setting not required	PMC66 = 1	PFCE66 = 1	PFC66 = 0	TQ0IS1, TQ0IS0 (TQ0IOC1) = 00, TQ0EES1, TQ0EES0 (TQ0IOC2) = 00, TQ0ETS1, TQ0ETS0 (TQ0IOC2) = 00
	TIQ00	Input	P66 = Setting not required	PM66 = Setting not required	PMC66 = 1	PFCE66 = 1	PFC66 = 0	KRM3 (KRM) = 0
	TOQ00	Output	P66 = Setting not required	PM66 = Setting not required	PMC66 = 1	PFCE66 = 1	PFC66 = 1	
P67	SOB5	Output	P67 = Setting not required	PM67 = Setting not required	PMC67 = 1	PFCE67 = 0 <sup>Note 2</sup>	PFC67 = 0	
	RXDA5	Input	P67 = Setting not required	PM67 = Setting not required	PMC67 = 1	PFCE67 = 0 <sup>Note 2</sup>	PFC67 = 1	
	SDA05 <sup>Note 1</sup>	I/O	P67 = Setting not required	PM67 = Setting not required	PMC67 = 1	PFCE67 = 1	PFC67 = 0	PF67 (PF6) = 1
P68	SCKB5	I/O	P68 = Setting not required	PM68 = Setting not required	PMC68 = 1	PFCE68 = 0 <sup>Note 2</sup>	PFC68 = 0	
	TXDA5	Output	P68 = Setting not required	PM68 = Setting not required	PMC68 = 1	PFCE68 = 0 <sup>Note 2</sup>	PFC68 = 1	
	SCL05 <sup>Note 1</sup>	I/O	P68 = Setting not required	PM68 = Setting not required	PMC68 = 1	PFCE68 = 1	PFC68 = 0	PF68 (PF6) = 1
P69	TIP70	Input	P69 = Setting not required	PM69 = Setting not required	PMC69 = 1	PFCE69 = 0	PFC69 = 0	
	TOP70	Output	P69 = Setting not required	PM69 = Setting not required	PMC69 = 1	PFCE69 = 0	PFC69 = 1	
	TENC70	Input	P69 = Setting not required	PM69 = Setting not required	PMC69 = 1	PFCE69 = 1	PFC69 = 0	
P610	TIP71	Input	P610 = Setting not required	PM610 = Setting not required	PMC610 = 1	PFCE610 = 0	PFC610 = 0	
	TENC71	Input	P610 = Setting not required	PM610 = Setting not required	PMC610 = 1	PFCE610 = 1	PFC610 = 0	
P611	TOP71	Output	P611 = Setting not required	PM611 = Setting not required	PMC611 = 1	PFCE611 = 0	PFC611 = 0	
	TECR7	Input	P611 = Setting not required	PM611 = Setting not required	PMC611 = 1	PFCE611 = 1	PFC611 = 0	
P612	TIP80	Input	P612 = Setting not required	PM612 = Setting not required	PMC612 = 1	PFCE612 = 0	PFC612 = 0	
	TOP80	Output	P612 = Setting not required	PM612 = Setting not required	PMC612 = 1	PFCE612 = 0	PFC612 = 1	
	TENC80	Input	P612 = Setting not required	PM612 = Setting not required	PMC612 = 1	PFCE612 = 1	PFC612 = 0	

- Notes 1.** These pins are not included in the  $\mu$ PD70F3931 (V850E/SJ3-H), 70F3932 (V850E/SJ3-H), and 70F3933 (V850E/SJ3-H).
- 2.** This setting is valid in products other than the  $\mu$ PD70F3931 (V850E/SJ3-H), 70F3932 (V850E/SJ3-H), and 70F3933 (V850E/SJ3-H). This setting cannot be specified in the  $\mu$ PD70F3931 (V850E/SJ3-H), 70F3932 (V850E/SJ3-H), and 70F3933 (V850E/SJ3-H).

Table 4-25. Using Port Pin as Alternate-Function Pin (7/13)

Pin Name	Alternate Function		Pnx Bit of Pn Register	PMnx Bit of PMn Register	PMCnx Bit of PMCn Register	PFCEnx Bit of PFCEn Register	PFCnx Bit of PFCn Register	Other Bits (Registers)
	Name	I/O						
P613	TIP81	Input	P613 = Setting not required	PM613 = Setting not required	PMC613 = 1	PFCE613 = 0	PFC613 = 0	
	TOP81	Output	P613 = Setting not required	PM613 = Setting not required	PMC613 = 1	PFCE613 = 0	PFC613 = 1	
	TENC81	Input	P613 = Setting not required	PM613 = Setting not required	PMC613 = 1	PFCE613 = 1	PFC613 = 0	
P614	SDA03	I/O	P614 = Setting not required	PM614 = Setting not required	PMC614 = 1	PFCE614 = 0	PFC614 = 0	PF614 (PF6) = 1
	TECR8	Input	P614 = Setting not required	PM614 = Setting not required	PMC614 = 1	PFCE614 = 1	PFC614 = 0	
P615	SCL03	I/O	P615 = Setting not required	PM615 = Setting not required	PMC615 = 1	–	–	PF615 (PF6) = 1
P70	ANI0	Input	P70 = Setting not required	PM70 = 1	–	–	–	
P71	ANI1	Input	P71 = Setting not required	PM71 = 1	–	–	–	
P72	ANI2	Input	P72 = Setting not required	PM72 = 1	–	–	–	
P73	ANI3	Input	P73 = Setting not required	PM73 = 1	–	–	–	
P74	ANI4	Input	P74 = Setting not required	PM74 = 1	–	–	–	
P75	ANI5	Input	P75 = Setting not required	PM75 = 1	–	–	–	
P76	ANI6	Input	P76 = Setting not required	PM76 = 1	–	–	–	
P77	ANI7	Input	P77 = Setting not required	PM77 = 1	–	–	–	
P78	ANI8	Input	P78 = Setting not required	PM78 = 1	–	–	–	
P79	ANI9	Input	P79 = Setting not required	PM79 = 1	–	–	–	
P710	ANI10	Input	P710 = Setting not required	PM710 = 1	–	–	–	
P711	ANI11	Input	P711 = Setting not required	PM711 = 1	–	–	–	
P712	ANI12	Input	P712 = Setting not required	PM712 = 1	–	–	–	
P713	ANI13	Input	P713 = Setting not required	PM713 = 1	–	–	–	
P714	ANI14	Input	P714 = Setting not required	PM714 = 1	–	–	–	
P715	ANI15	Input	P715 = Setting not required	PM715 = 1	–	–	–	

Table 4-25. Using Port Pin as Alternate-Function Pin (8/13)

Pin Name	Alternate Function		Pnx Bit of Pn Register	PMnx Bit of PMn Register	PMCnx Bit of PMCn Register	PFCEnx Bit of PFCEn Register	PFCnx Bit of PFCn Register	Other Bits (Registers)
	Name	I/O						
P80	RXDA3	Input	P80 = Setting not required	PM80 = Setting not required	PMC80 = 1	PFCE80 = 0	PFC80 = 0	<b>Note 2</b>
	INTP8	Input	P80 = Setting not required	PM80 = Setting not required	PMC80 = 1	PFCE80 = 0	PFC80 = 0	<b>Note 2</b>
	RC1CK1HZ	Output	P80 = Setting not required	PM80 = Setting not required	PMC80 = 1	PFCE80 = 1	PFC80 = 0	
P81	TXDA3	Output	P81 = Setting not required	PM81 = Setting not required	PMC81 = 1	PFCE81 = 0	PFC81 = 0	
	RC1CKO	Output	P81 = Setting not required	PM81 = Setting not required	PMC81 = 1	PFCE81 = 1	PFC81 = 0	RC1CC3.CLOE2 bit = 0
	RC1CKDIV	Output	P81 = Setting not required	PM81 = Setting not required	PMC81 = 1	PFCE81 = 1	PFC81 = 0	RC1CC1.CLOE0 bit = 0
P82 <sup>Note 1</sup>	SDA05 <sup>Note 1</sup>	I/O	P82 = Setting not required	PM82 = Setting not required	PMC82 = 1	–	–	PF82 (PF8) = 1
P83 <sup>Note 1</sup>	SCL05 <sup>Note 1</sup>	I/O	P83 = Setting not required	PM83 = Setting not required	PMC83 = 1	–	–	PF83 (PF8) = 1
P84 <sup>Note 1</sup>	RXDA5 <sup>Note 1</sup>	Input	P84 = Setting not required	PM84 = Setting not required	PMC84 = 1	–	–	
P85 <sup>Note 1</sup>	TXDA5 <sup>Note 1</sup>	Output	P85 = Setting not required	PM85 = Setting not required	PMC85 = 1	–	–	
P90	A0	Output	P90 = Setting not required	PM90 = Setting not required	PMC90 = 1	PFCE90 = 0	PFC90 = 0	<b>Note 3</b>
	KR6	Input	P90 = Setting not required	PM90 = Setting not required	PMC90 = 1	PFCE90 = 0	PFC90 = 1	
	TXDA1	Output	P90 = Setting not required	PM90 = Setting not required	PMC90 = 1	PFCE90 = 1	PFC90 = 0	
	SDA02	I/O	P90 = Setting not required	PM90 = Setting not required	PMC90 = 1	PFCE90 = 1	PFC90 = 1	PF90 (PF9) = 1

**Notes 1.** Valid for the V850E/SK3-H only.

- The INTP8 pin and RXDA3 pin are alternate-function pins. When using the pin as the RXDA3 pin, disable edge detection for the INTP8 alternate-function pin. (Clear the INTF8.INTF80 bit and the INTR8.INTR80 bit to 0.) When using the pin as the INTP8 pin, stop UARTA3 reception. (Clear the UA3CTL0.UA3RXE bit to 0.)
- Port 9 pins cannot be used as port pins or other alternate-function pins if even one of the A0 to A15 pins is used in the separate bus mode. After setting the PFC9 and PFCE9 registers to 0000H, therefore, set all 16 bits of the PMC9 register to FFFFH at once.



Table 4-25. Using Port Pin as Alternate-Function Pin (9/13)

Pin Name	Alternate Function		Pnx Bit of Pn Register	PMnx Bit of PMn Register	PMCnx Bit of PMCn Register	PFCEnx Bit of PFCEn Register	PFCnx Bit of PFCn Register	Other Bits (Registers)
	Name	I/O						
P91	A1	Output	P91 = Setting not required	PM91 = Setting not required	PMC91 = 1	PFCE91 = 0	PFC91 = 0	<b>Note 2</b>
	KR7	Input	P91 = Setting not required	PM91 = Setting not required	PMC91 = 1	PFCE91 = 0	PFC91 = 1	
	RXDA1 <sup>Note 1</sup>	Input	P91 = Setting not required	PM91 = Setting not required	PMC91 = 1	PFCE91 = 1	PFC91 = 0	
	KR7 <sup>Note 1</sup>	Input	P91 = Setting not required	PM91 = Setting not required	PMC91 = 1	PFCE91 = 1	PFC91 = 0	
	SCL02	I/O	P91 = Setting not required	PM91 = Setting not required	PMC91 = 1	PFCE91 = 1	PFC91 = 1	PF91 (PF9) = 1
P92	A2	Output	P92 = Setting not required	PM92 = Setting not required	PMC92 = 1	PFCE92 = 0	PFC92 = 0	<b>Note 2</b>
	TIP41	Input	P92 = Setting not required	PM92 = Setting not required	PMC92 = 1	PFCE92 = 0	PFC92 = 1	
	TOP41	Output	P92 = Setting not required	PM92 = Setting not required	PMC92 = 1	PFCE92 = 1	PFC92 = 0	
P93	A3	Output	P93 = Setting not required	PM93 = Setting not required	PMC93 = 1	PFCE93 = 0	PFC93 = 0	<b>Note 2</b>
	TIP40	Input	P93 = Setting not required	PM93 = Setting not required	PMC93 = 1	PFCE93 = 0	PFC93 = 1	
	TOP40	Output	P93 = Setting not required	PM93 = Setting not required	PMC93 = 1	PFCE93 = 1	PFC93 = 0	
	INTP8	Input	P93 = Setting not required	PM93 = Setting not required	PMC93 = 1	PFCE93 = 1	PFC93 = 1	
P94	A4	Output	P94 = Setting not required	PM94 = Setting not required	PMC94 = 1	PFCE94 = 0	PFC94 = 0	<b>Note 2</b>
	TIP31	Input	P94 = Setting not required	PM94 = Setting not required	PMC94 = 1	PFCE94 = 0	PFC94 = 1	
	TOP31	Output	P94 = Setting not required	PM94 = Setting not required	PMC94 = 1	PFCE94 = 1	PFC94 = 0	
P95	A5	Output	P95 = Setting not required	PM95 = Setting not required	PMC95 = 1	PFCE95 = 0	PFC95 = 0	<b>Note 2</b>
	TIP30	Input	P95 = Setting not required	PM95 = Setting not required	PMC95 = 1	PFCE95 = 0	PFC95 = 1	
	TOP30	Output	P95 = Setting not required	PM95 = Setting not required	PMC95 = 1	PFCE95 = 1	PFC95 = 0	
	INTP5	Input	P95 = Setting not required	PM95 = Setting not required	PMC95 = 1	PFCE95 = 1	PFC95 = 1	

- Notes 1.** The RXDA1 and KR7 pins must not be used at the same time. When using the RXDA1 pin, do not use the KR7 pin (clear the KRM.KRM7 bit to 0). When using the KR7 pin, do not use the RXDA1 pin (it is recommended to set the PFC91 bit to 1 and clear the PFCE91 bit to 0. When the PFC91 bit is cleared to 0 and the PFCE91 bit is set to one, clear the UA1RXE bit to 0).
- 2.** Port 9 pins cannot be used as port pins or other alternate-function pins if even one of the A0 to A15 pins is used in the separate bus mode. After setting the PFC9 and PFCE9 registers to 0000H, therefore, set all 16 bits of the PMC9 register to FFFFH at once.

Table 4-25. Using Port Pin as Alternate-Function Pin (10/13)

Pin Name	Alternate Function		Pnx Bit of Pn Register	PMnx Bit of PMn Register	PMCnx Bit of PMCn Register	PFCEnx Bit of PFCEn Register	PFCnx Bit of PFCn Register	Other Bits (Registers)
	Name	I/O						
P96	A6	Output	P96 = Setting not required	PM96 = Setting not required	PMC96 = 1	PFCE96 = 0	PFC96 = 0	<b>Note</b>
	TIP21	Input	P96 = Setting not required	PM96 = Setting not required	PMC96 = 1	PFCE96 = 1	PFC96 = 0	
	TOP21	Output	P96 = Setting not required	PM96 = Setting not required	PMC96 = 1	PFCE96 = 1	PFC96 = 1	
P97	A7	Output	P97 = Setting not required	PM97 = Setting not required	PMC97 = 1	PFCE97 = 0	PFC97 = 0	<b>Note</b>
	SIB1	Input	P97 = Setting not required	PM97 = Setting not required	PMC97 = 1	PFCE97 = 0	PFC97 = 1	
	TIP20	Input	P97 = Setting not required	PM97 = Setting not required	PMC97 = 1	PFCE97 = 1	PFC97 = 0	
	TOP20	Output	P97 = Setting not required	PM97 = Setting not required	PMC97 = 1	PFCE97 = 1	PFC97 = 1	
P98	A8	Output	P98 = Setting not required	PM98 = Setting not required	PMC98 = 1	–	PFC98 = 0	<b>Note</b>
	SOB1	Output	P98 = Setting not required	PM98 = Setting not required	PMC98 = 1	–	PFC98 = 1	
P99	A9	Output	P99 = Setting not required	PM99 = Setting not required	PMC99 = 1	–	PFC99 = 0	<b>Note</b>
	$\overline{\text{SCKB1}}$	I/O	P99 = Setting not required	PM99 = Setting not required	PMC99 = 1	–	PFC99 = 1	
P910	A10	Output	P910 = Setting not required	PM910 = Setting not required	PMC910 = 1	–	PFC910 = 0	<b>Note</b>
	SIB3	Input	P910 = Setting not required	PM910 = Setting not required	PMC910 = 1	–	PFC910 = 1	
P911	A11	Output	P911 = Setting not required	PM911 = Setting not required	PMC911 = 1	–	PFC911 = 0	<b>Note</b>
	SOB3	Output	P911 = Setting not required	PM911 = Setting not required	PMC911 = 1	–	PFC911 = 1	
P912	A12	Output	P912 = Setting not required	PM912 = Setting not required	PMC912 = 1	–	PFC912 = 0	<b>Note</b>
	$\overline{\text{SCKB3}}$	I/O	P912 = Setting not required	PM912 = Setting not required	PMC912 = 1	–	PFC912 = 1	
P913	A13	Output	P913 = Setting not required	PM913 = Setting not required	PMC913 = 1	–	PFC913 = 0	<b>Note</b>
	INTP4	Input	P913 = Setting not required	PM913 = Setting not required	PMC913 = 1	–	PFC913 = 1	
P914	A14	Output	P914 = Setting not required	PM914 = Setting not required	PMC914 = 1	PFCE914 = 0	PFC914 = 0	<b>Note</b>
	INTP5	Input	P914 = Setting not required	PM914 = Setting not required	PMC914 = 1	PFCE914 = 0	PFC914 = 1	
	TIP51	Input	P914 = Setting not required	PM914 = Setting not required	PMC914 = 1	PFCE914 = 1	PFC914 = 0	
	TOP51	Output	P914 = Setting not required	PM914 = Setting not required	PMC914 = 1	PFCE914 = 1	PFC914 = 1	

**Note** Port 9 pins cannot be used as port pins or other alternate-function pins if even one of the A0 to A15 pins is used in the separate bus mode. After setting the PFC9 and PFCE9 registers to 0000H, therefore, set all 16 bits of the PMC9 register to FFFFH at once.

Table 4-25. Using Port Pin as Alternate-Function Pin (11/13)

Pin Name	Alternate Function		Pnx Bit of Pn Register	PMnx Bit of PMn Register	PMCnx Bit of PMCn Register	PFCEnx Bit of PFCEn Register	PFCnx Bit of PFCn Register	Other Bits (Registers)
	Name	I/O						
P915	A15	Output	P915 = Setting not required	PM915 = Setting not required	PMC915 = 1	PFCE915 = 0	PFC915 = 0	<b>Note 3</b>
	INTP6	Input	P915 = Setting not required	PM915 = Setting not required	PMC915 = 1	PFCE915 = 0	PFC915 = 1	
	TIP50	Input	P915 = Setting not required	PM915 = Setting not required	PMC915 = 1	PFCE915 = 1	PFC915 = 0	
	TOP50	Output	P915 = Setting not required	PM915 = Setting not required	PMC915 = 1	PFCE915 = 1	PFC915 = 1	
P150 <sup>Note 1</sup>	RXDA1 <sup>Notes 1, 2</sup>	Input	P150 = Setting not required	PM150 = Setting not required	PMC150 = 1	–	–	
	KR7 <sup>Notes 1, 2</sup>	Input	P150 = Setting not required	PM150 = Setting not required	PMC150 = 1	–	–	
P151 <sup>Note 1</sup>	TXDA1 <sup>Note 1</sup>	Output	P151 = Setting not required	PM151 = Setting not required	PMC151 = 1	–	–	
P152 <sup>Note 1</sup>	INTP9 <sup>Note 1</sup>	Input	P152 = Setting not required	PM152 = Setting not required	PMC152 = 1	–	–	
P153 <sup>Note 1</sup>	INTP6 <sup>Note 1</sup>	Input	P153 = Setting not required	PM153 = Setting not required	PMC153 = 1	–	–	
PCD0	RXDB0	Input	PCD0 = Setting not required	PMCD0 = Setting not required	PMCCD0 = 1	–	PFCCD0 = 1	
PCD1	TXDB0	Output	PCD1 = Setting not required	PMCD1 = Setting not required	PMCCD1 = 1	–	PFCCD1 = 1	
PCD2	RXDB1	Input	PCD2 = Setting not required	PMCD2 = Setting not required	PMCCD2 = 1	–	PFCCD2 = 1	
PCD3	TXDB1	Output	PCD3 = Setting not required	PMCD3 = Setting not required	PMCCD3 = 1	–	PFCCD3 = 1	
PCM0	WAIT	Input	PCM0 = Setting not required	PMCM0 = Setting not required	PMCCM0 = 1	–	–	
PCM1	CLKOUT	Output	PCM1 = Setting not required	PMCM1 = Setting not required	PMCCM1 = 1	–	–	
PCM2	HLDK	Output	PCM2 = Setting not required	PMCM2 = Setting not required	PMCCM2 = 1	–	–	
PCM3	HLDK	Input	PCM3 = Setting not required	PMCM3 = Setting not required	PMCCM3 = 1	–	–	
PCS1	CS1	Output	PCS1 = Setting not required	PMCS1 = Setting not required	PMCCS1 = 1	–	–	
PCS2	CS2	Output	PCS2 = Setting not required	PMCS2 = Setting not required	PMCCS2 = 1	–	–	
PCS3	CS3	Output	PCS3 = Setting not required	PMCS3 = Setting not required	PMCCS3 = 1	–	–	

**Notes 1.** V850E/SK3-H only.

- The RXDA1 and KR7 pins must not be used at the same time. When using the RXDA1 pin, do not use the KR7 pin (clear the KRM.KRM7 bit to 0). When using the KR7 pin, do not use the RXDA1 pin (clear the UA1CTL0.UA1RXE bit to 0).
- Port 9 pins cannot be used as port pins or other alternate-function pins if even one of the A0 to A15 pins is used in the separate bus mode. After setting the PFC9 and PFCE9 registers to 0000H, therefore, set all 16 bits of the PMC9 register to FFFFH at once.

Table 4-25. Using Port Pin as Alternate-Function Pin (12/13)

Pin Name	Alternate Function		Pnx Bit of Pn Register	PMnx Bit of PMn Register	PMCnx Bit of PMCn Register	PFCEnx Bit of PFCEn Register	PFCnx Bit of PFCn Register	Other Bits (Registers)
	Name	I/O						
PCT0	$\overline{\text{WR0}}$	Output	PCT0 = Setting not required	PMCT0 = Setting not required	PMCCT0 = 1	–	–	
PCT1	$\overline{\text{WR1}}$	Output	PCT1 = Setting not required	PMCT1 = Setting not required	PMCCT1 = 1	–	–	
PCT4	$\overline{\text{RD}}$	Output	PCT4 = Setting not required	PMCT4 = Setting not required	PMCCT4 = 1	–	–	
PCT6	ASTB	Output	PCT6 = Setting not required	PMCT6 = Setting not required	PMCCT6 = 1	–	–	
PDH0	A16	Output	PDH0 = Setting not required	PMDH0 = Setting not required	PMCDH0 = 1	–	–	
PDH1	A17	Output	PDH1 = Setting not required	PMDH1 = Setting not required	PMCDH1 = 1	–	–	
PDH2	A18	Output	PDH2 = Setting not required	PMDH2 = Setting not required	PMCDH2 = 1	–	–	
PDH3	A19	Output	PDH3 = Setting not required	PMDH3 = Setting not required	PMCDH3 = 1	–	–	
PDH4	A20	Output	PDH4 = Setting not required	PMDH4 = Setting not required	PMCDH4 = 1	–	–	
PDH5	A21	Output	PDH5 = Setting not required	PMDH5 = Setting not required	PMCDH5 = 1	–	–	
PDH6	A22	Output	PDH6 = Setting not required	PMDH6 = Setting not required	PMCDH6 = 1	–	–	
PDH7	A23	Output	PDH7 = Setting not required	PMDH7 = Setting not required	PMCDH7 = 1	–	–	

Table 4-25. Using Port Pin as Alternate-Function Pin (13/13)

Pin Name	Alternate Function		Pnx Bit of Pn Register	PMnx Bit of PMn Register	PMCnx Bit of PMCn Register	PFCEnx Bit of PFCEn Register	PFCnx Bit of PFCn Register	Other Bits (Registers)
	Name	I/O						
PDL0	AD0	I/O	PDL0 = Setting not required	PMDL0 = Setting not required	PMCDL0 = 1	–	–	
PDL1	AD1	I/O	PDL1 = Setting not required	PMDL1 = Setting not required	PMCDL1 = 1	–	–	
PDL2	AD2	I/O	PDL2 = Setting not required	PMDL2 = Setting not required	PMCDL2 = 1	–	–	
PDL3	AD3	I/O	PDL3 = Setting not required	PMDL3 = Setting not required	PMCDL3 = 1	–	–	
PDL4	AD4	I/O	PDL4 = Setting not required	PMDL4 = Setting not required	PMCDL4 = 1	–	–	
PDL5	AD5	I/O	PDL5 = Setting not required	PMDL5 = Setting not required	PMCDL5 = 1	–	–	
	FLMD1 <sup>Note</sup>	Input	PDL5 = Setting not required	PMDL5 = Setting not required	PMCDL5 = Setting not required	–	–	
PDL6	AD6	I/O	PDL6 = Setting not required	PMDL6 = Setting not required	PMCDL6 = 1	–	–	
PDL7	AD7	I/O	PDL7 = Setting not required	PMDL7 = Setting not required	PMCDL7 = 1	–	–	
PDL8	AD8	I/O	PDL8 = Setting not required	PMDL8 = Setting not required	PMCDL8 = 1	–	–	
PDL9	AD9	I/O	PDL9 = Setting not required	PMDL9 = Setting not required	PMCDL9 = 1	–	–	
PDL10	AD10	I/O	PDL10 = Setting not required	PMDL10 = Setting not required	PMCDL10 = 1	–	–	
PDL11	AD11	I/O	PDL11 = Setting not required	PMDL11 = Setting not required	PMCDL11 = 1	–	–	
PDL12	AD12	I/O	PDL12 = Setting not required	PMDL12 = Setting not required	PMCDL12 = 1	–	–	
PDL13	AD13	I/O	PDL13 = Setting not required	PMDL13 = Setting not required	PMCDL13 = 1	–	–	
PDL14	AD14	I/O	PDL14 = Setting not required	PMDL14 = Setting not required	PMCDL14 = 1	–	–	
PDL15	AD15	I/O	PDL15 = Setting not required	PMDL15 = Setting not required	PMCDL15 = 1	–	–	

**Note** Since this pin is set in the flash memory programming mode, it does not need to be manipulated with the port control register. For details, see **CHAPTER 32 FLASH MEMORY**.

## 4.6 Cautions

### 4.6.1 Cautions on setting port pins

(1) In the V850E/SJ3-H and V850E/SK3-H, the general-purpose port function and several peripheral function I/O pin share a pin. To switch between the general-purpose port (port mode) and the peripheral function I/O pin (alternate-function mode), set by the PMCn register. In regards to this register setting sequence, note with caution the following.

(a) Cautions on switching from port mode to alternate-function mode

To switch from the port mode to alternate-function mode in the following order.

- <1> Set the PFn register<sup>Note</sup>: N-ch open-drain setting
- <2> Set the PFCn and PFCEn registers: Alternate-function selection
- <3> Set the corresponding bit of the PMCn register to 1: Switch to alternate-function mode

If the PMCn register is set first, note with caution that, at that moment or depending on the change of the pin states in accordance with the setting of the PFn, PFCn, and PFCEn registers, unexpected operations may occur.

A concrete example is shown as Example below.

**Note** N-ch open-drain output pin only

**Caution** Regardless of the port mode/alternate-function mode, the Pn register is read and written as follows.

- **Pn register read:** Read the port output latch value (when PMn.PMnm bit = 0), or read the pin states (PMn.PMnm bit = 1).
- **Pn register write:** Write to the port output latch

[Example] SCL01 pin setting example

The SCL01 pin is used alternately with the P41/SOB0 pin. Select the valid pin functions with the PMC4, PFC4, and PF4 registers.

PMC41 Bit	PFC41 Bit	PF41 Bit	Valid Pin Functions
0	don't care	1	P41 (in output port mode, N-ch open-drain output)
1	0	1	SOB0 output (N-ch open-drain output)
	1	1	SCL01 I/O (N-ch open-drain output)

The order of setting in which malfunction may occur on switching from the P41 pin to the SCL01 pin are shown below.

Setting Order	Setting Contents	Pin States	Pin Level
<1>	Initial value (PMC41 bit = 0, PFC41 bit = 0, PF41 bit = 0)	Port mode (input)	Hi-Z
<2>	PMC41 bit ← 1	SOB0 output	Low level (high level depending on the CSIB0 setting)
<3>	PFC41 bit ← 1	SCL01 I/O	High level (CMOS output)
<4>	PF41 bit ← 1	SCL01 I/O	Hi-Z (N-ch open-drain output)

In <2>, I<sup>2</sup>C communication may be affected since the alternate-function SOB0 output is output to the pin. In the CMOS output period of <2> or <3>, unnecessary current may be generated.

(b) Cautions on alternate-function mode (input)

The input signal to the alternate-function block is low level when the PMCn.PMCnm bit is 0 due to the AND output of the PMCn register set value and the pin level. Thus, depending on the port setting and alternate-function operation enable timing, unexpected operations may occur. Therefore, switch between the port mode and alternate-function mode in the following sequence.

- To switch from port mode to alternate-function mode (input)  
Set the pins to the alternate-function mode using the PMCn register and then enable the alternate-function operation.
- To switch from alternate-function mode (input) to port mode  
Stop the alternate-function operation and then switch the pins to the port mode.

The concrete examples are shown as Example 1 and Example 2.

[Example 1] Switch from general-purpose port (P02) to external interrupt pin (NMI)

When the P02/NMI pin is pulled up as shown in Figure 4-68 and the rising edge is specified in the NMI pin edge detection setting, even though high level is input continuously to the NMI pin during switching from the P02 pin to the an NMI pin (PMC02 bit = 0 → 1), this is detected as a rising edge as if the low level changed to high level, and an NMI interrupt occurs.

To avoid it, set the NMI pin's valid edge after switching from the P02 pin to the NMI pin.

Figure 4-68. Example of Switching from P02 to NMI (Incorrect)

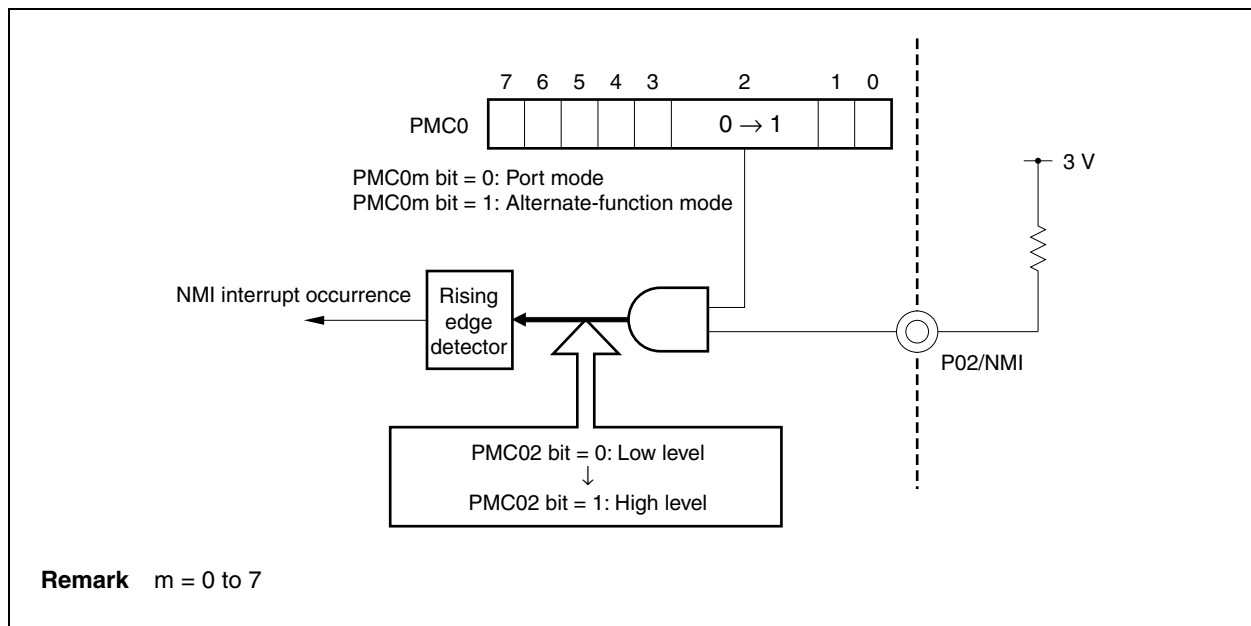

[Example 2] Switch from external pin (NMI) to general-purpose port (P02)  
 When the P02/NMI pin is pulled up as shown in Figure 4-69 and the falling edge is specified in the NMI pin edge detection setting, even though high level is input continuously to the NMI pin at switching from the NMI pin to the P02 pin (PMC02 bit = 1 → 0), this is detected as falling edge as if high level changed to low level, and NMI interrupt occurs.  
 To avoid this, set the NMI pin edge detection as “No edge detected” before switching to the P02 pin.

Figure 4-69. Example of Switching from NMI to P02 (Incorrect)

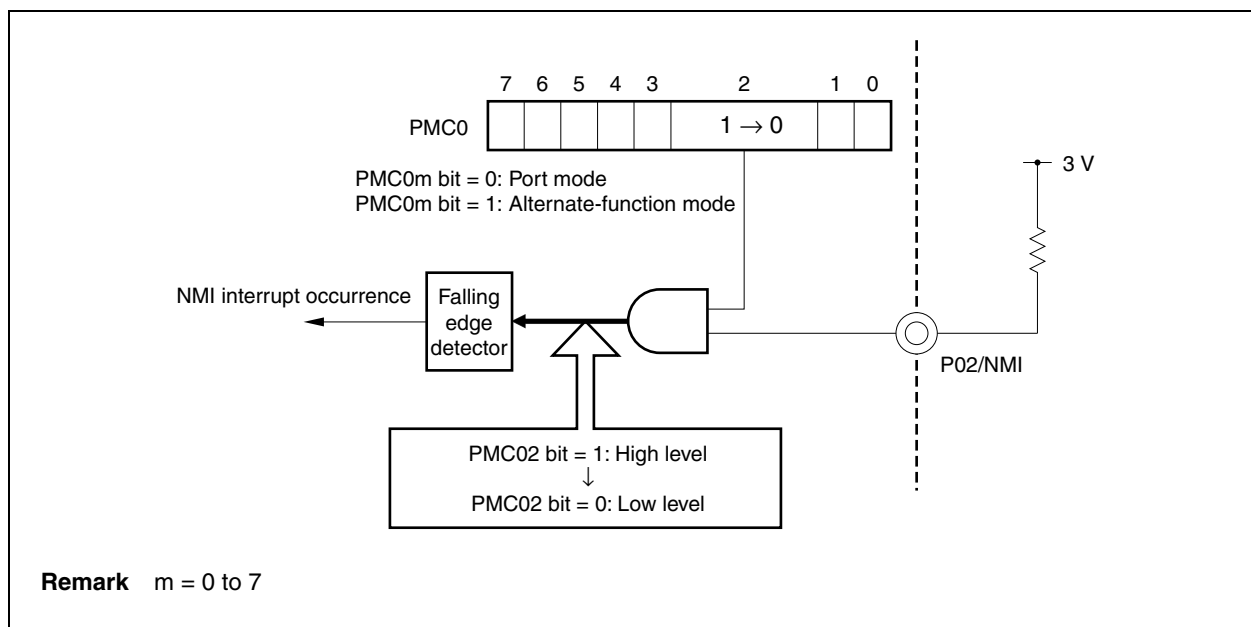

(2) In port mode, the PFn.PFnm bit is valid only in the output mode (PMn.PMnm bit = 0). In the input mode (PMnm bit = 1), the value of the PFnm bit is not reflected in the buffer.



**4.6.2 Cautions on bit manipulation instruction for port n register (Pn)**

When a 1-bit manipulation instruction is executed on a port that provides both input and output functions, the value of the output latch of an input port that is not subject to manipulation may be written in addition to the targeted bit.

Therefore, it is recommended to rewrite the output latch when switching a port from input mode to output mode.

<Example> When P90 pin is an output port, P91 to P97 pins are input ports (all pin statuses are high level), and the value of the port latch is 00H, if the output of P90 pin is changed from low level to high level via a bit manipulation instruction, the value of the port latch is FFH.

Explanation: The targets of writing to and reading from the Pn register of a port whose PMnm bit is 1 are the output latch and pin status, respectively.

A bit manipulation instruction is executed in the following order in the V850E/SJ3-H and V850E/SK3-H.

- <1> The Pn register is read in 8-bit units.
- <2> The targeted one bit is manipulated.
- <3> The Pn register is written in 8-bit units.

In step <1>, the value of the output latch (0) of P90 pin, which is an output port, is read, while the pin statuses of P91 to P97 pins, which are input ports, are read. If the pin statuses of P91 to P97 pins are high level at this time, the read value is FEH.

The value is changed to FFH by the manipulation in <2>.

FFH is written to the output latch by the manipulation in <3>.

**Figure 4-70. Bit Manipulation Instruction (P90 Pin)**

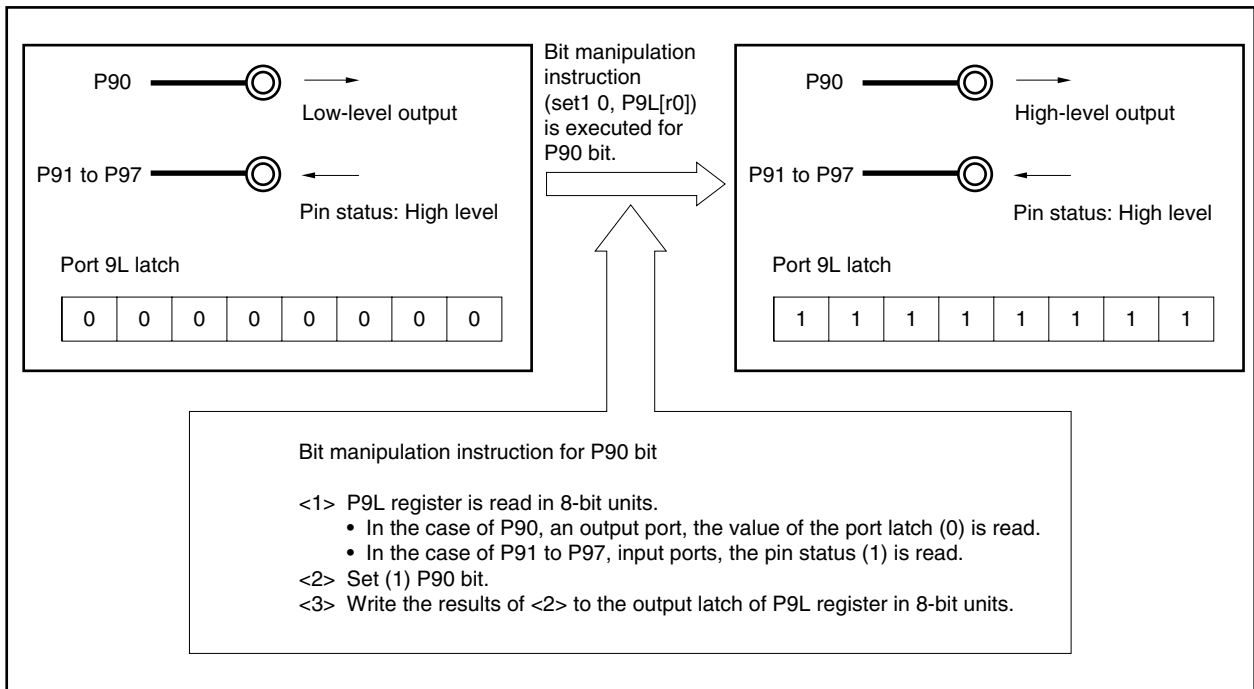

### 4.6.3 Cautions on on-chip debug pins

The  $\overline{\text{DRST}}$ , DCK, DMS, DDI, and DDO pins are on-chip debug pins.

After reset by the  $\overline{\text{RESET}}$  pin, the P05/INTP2/ $\overline{\text{DRST}}$  pin is initialized to function as an on-chip debug pin ( $\overline{\text{DRST}}$ ). If a high level is input to the  $\overline{\text{DRST}}$  pin at this time, the on-chip debug mode is set, and the DCK, DMS, DDI, and DDO pins can be used.

The following action must be taken if on-chip debugging is not used.

- Clear the OCDM0 bit of the OCDM register (special register) (0)

At this time, fix the P05/INTP2/ $\overline{\text{DRST}}$  pin to low level from when reset by the  $\overline{\text{RESET}}$  pin is released until the above action is taken.

If a high level is input to the  $\overline{\text{DRST}}$  pin before the above action is taken, it may cause a malfunction (CPU deadlock). Handle the P05 pin with the utmost care.

**Caution** The P05/INTP2/ $\overline{\text{DRST}}$  pin is not initialized to function as an on-chip debug pin ( $\overline{\text{DRST}}$ ) when a reset signal (WDT2RES) is generated due to a watchdog timer overflow, a reset signal (LVIREs) is generated by the low-voltage detector (LVI), or a reset signal (CLMRES) is generated by the clock monitor (CLM). The OCDM register holds the current value.

### 4.6.4 Cautions on P05/INTP2/ $\overline{\text{DRST}}$ pin

The P05/INTP2/ $\overline{\text{DRST}}$  pin has an internal pull-down resistor (30 k $\Omega$  TYP.). After a reset by the  $\overline{\text{RESET}}$  pin, a pull-down resistor is connected. The pull-down resistor is disconnected when the OCDM0 bit is cleared (0).

### 4.6.5 Cautions on P53 pin when power is turned on

When the power is turned on, the following pins may momentarily output an undefined level.

- P53/SIB2/KR3/TIQ00/TOQ00/RTP03/DDO pin

### 4.6.6 Hysteresis characteristics

In port mode, the following port pins do not have hysteresis characteristics.

P00 to P06

P20<sup>Note</sup>, P21<sup>Note</sup>

P31 to P35, P37 to P39, P312<sup>Note</sup>

P40 to P42, P45<sup>Note</sup>

P50 to P55, P56<sup>Note</sup>

P60, P62 to P615

P80, P82 to P84<sup>Note</sup>

P90 to P97, P99, P910, P912 to P915

P150<sup>Note</sup>, P152<sup>Note</sup>, P153<sup>Note</sup>

PCD0, PCD2

**Note** V850E/SK3-H only

**4.6.7 Cautions on separate bus mode**

Port 9 pins cannot be used as port pins or other alternate-function pins if even one of the A0 to A15 pins is used in the separate bus mode. After setting the PFC9 and PFCE9 registers to 0000H, therefore, set all 16 bits of the PMC9 register to FFFFH at once. If none of the A0 to A15 pins is used in the separate bus mode, port 9 pins can be used as port pins or other alternate-function pins.

**4.6.8 Cautions on reading port n registers (Pn: n = 3 to 5, 8) (V850E/SJ3-H only)**

In the V850E/SJ3-H, the bit values of the following port n registers become undefined when read.

Port 3 register: P310 to P312

Port 4 register: P43 to P45

Port 5 register: P56, P57

Port 8 register: P82 to P85

**4.6.9 Cautions on setting port n mode control registers (PMcn: n = 3 to 5, 8)**

In the V850E/SJ3-H, be sure to set the bits of the following port n mode control registers to 0.

Port 3 mode control register: PMC310 to PMC312

Port 4 mode control register: PMC44, PMC45

Port 5 mode control register: PMC56, PMC57

Port 8 mode control register: PMC82 to PMC85

## CHAPTER 5 BUS CONTROL FUNCTION

The V850E/SJ3-H and V850E/SK3-H are provided with an external bus interface function by which external memories such as ROM and RAM, and I/O can be connected.

### 5.1 Features

- Output is selectable from a multiplexed bus with a minimum of 3 bus cycles and a separate bus with a minimum of 2 bus cycles.
- 8-bit/16-bit data bus selectable
- Wait function
  - Programmable wait function of up to 7 states
  - External wait function using  $\overline{\text{WAIT}}$  pin
- Idle state function
- Bus hold function
- <R> ○ Up to about 30 MB of physical memory connectable
- The bus can be controlled at a different voltage from the operating voltage when  $BV_{DD} \leq EV_{DD} = V_{DD}$ . However, set  $BV_{DD} = EV_{DD} = V_{DD}$  in the separate bus mode.

## 5.2 Bus Control Pins

The pins used to connect an external device are listed in the table below.

**Table 5-1. Bus Control Pins**

**(a) When multiplexed bus is selected**

Bus Control Pin	Alternate-Function Pin	I/O	Function
AD0 to AD15	PDL0 to PDL15	I/O	Address/data bus
A16 to A23	PDH0 to PDH7	Output	Address bus
$\overline{\text{WAIT}}$	PCM0	Input	External wait control
CLKOUT	PCM1	Output	Internal system clock
$\overline{\text{WR0}}, \overline{\text{WR1}}$	PCT0, PCT1	Output	Write strobe signal
$\overline{\text{RD}}$	PCT4	Output	Read strobe signal
ASTB	PCT6	Output	Address strobe signal
$\overline{\text{HLDRQ}}$	PCM3	Input	Bus hold control
$\overline{\text{HLDK}}$	PCM2	Output	
$\overline{\text{CS1}}$ to $\overline{\text{CS3}}$	PCS1 to PCS3	Output	Chip select

**(b) When separate bus is selected**

Bus Control Pin	Alternate-Function Pin	I/O	Function
AD0 to AD15	PDL0 to PDL15	I/O	Data bus
A0 to A15	P90 to P915	Output	Address bus
A16 to A23	PDH0 to PDH7	Output	Address bus
$\overline{\text{WAIT}}$	PCM0	Input	External wait control
CLKOUT	PCM1	Output	Internal system clock
$\overline{\text{WR0}}, \overline{\text{WR1}}$	PCT0, PCT1	Output	Write strobe signal
$\overline{\text{RD}}$	PCT4	Output	Read strobe signal
$\overline{\text{HLDRQ}}$	PCM3	Input	Bus hold control
$\overline{\text{HLDK}}$	PCM2	Output	
$\overline{\text{CS1}}$ to $\overline{\text{CS3}}$	PCS1 to PCS3	Output	Chip select

### 5.2.1 Pin status when internal ROM, internal RAM, on-chip peripheral I/O, or expanded internal RAM is accessed

When the internal ROM, internal RAM, on-chip peripheral I/O, or expanded internal RAM is accessed, the status of each pin is as follows.

**Table 5-2. Pin Statuses When Internal ROM, Internal RAM, On-Chip Peripheral I/O, or Expanded Internal RAM Is Accessed**

#### (a) When internal ROM, internal RAM, or on-chip peripheral I/O is accessed

Separate Bus Mode			Multiplexed Bus Mode		
Address bus (A23 to A0)		Undefined	Address bus (A23 to A16)		Undefined
Address/data bus (AD15 to AD0)		High impedance	Address/data bus (AD15 to AD0)		Undefined
Control signal	$\overline{CS1}$ to $\overline{CS3}$	Inactive level	Control signal	$\overline{CS1}$ to $\overline{CS3}$	Inactive level
	$\overline{RD}$ , $\overline{WR0}$ , $\overline{WR1}$ , ASTB	Inactive level		$\overline{RD}$ , $\overline{WR0}$ , $\overline{WR1}$ , ASTB	Inactive level

**Caution** When the internal ROM is written, as well as when the external memory area is accessed, the address bus, address/data bus, and control signals are activated, but write access is prohibited.

#### (b) When expanded internal RAM is accessed

Separate Bus Mode			Multiplexed Bus Mode		
Address bus (A23 to A0)		Undefined	Address bus (A23 to A16)		Undefined
Address/data bus (AD15 to AD0)		Undefined	Address/data bus (AD15 to AD0)		Undefined
Control signal	$\overline{CS1}$ to $\overline{CS3}$	Inactive level	Control signal	$\overline{CS1}$ to $\overline{CS3}$	Inactive level
	$\overline{RD}$ , $\overline{WR0}$ , $\overline{WR1}$ , ASTB	Active level		$\overline{RD}$ , $\overline{WR0}$ , $\overline{WR1}$ , ASTB	Active level

**Caution** When the expanded internal RAM is accessed, control signals ( $\overline{RD}$ ,  $\overline{WR0}$ ,  $\overline{WR1}$ , ASTB) are activated. Therefore, accesses to the external memory or external I/O must be controlled by the  $\overline{CSn}$  signal (n = 1 to 3).

### 5.2.2 Pin status in each operation mode

For the pin status of the V850E/SJ3-H and V850E/SK3-H in each operation mode, see 2.3 Pin States.

### 5.3 Memory Block Function

The 28 MB external memory space is divided into memory blocks of 4 MB, 4MB, 4MB, and 16 MB, from the lower address, and they can be used as three CS spaces ( $\overline{CS1}$ ,  $\overline{CS2}$ ,  $\overline{CS3}$ ). The correspondence between the  $\overline{CS1}$  and  $\overline{CS3}$  spaces and the memory block can be set by the CSC0 and CSC1 registers. In addition, the programmable wait function and bus size can be independently controlled for each CS space.

If the expanded internal RAM is not used, addresses 3E00000H to 3FEBFFFH can be used as external memory area by setting the CSC0 and CSC1 registers. Therefore, an external memory space of up to about 30 MB can be used.

Figure 5-1. Data Memory Map: Physical Address (1/2)

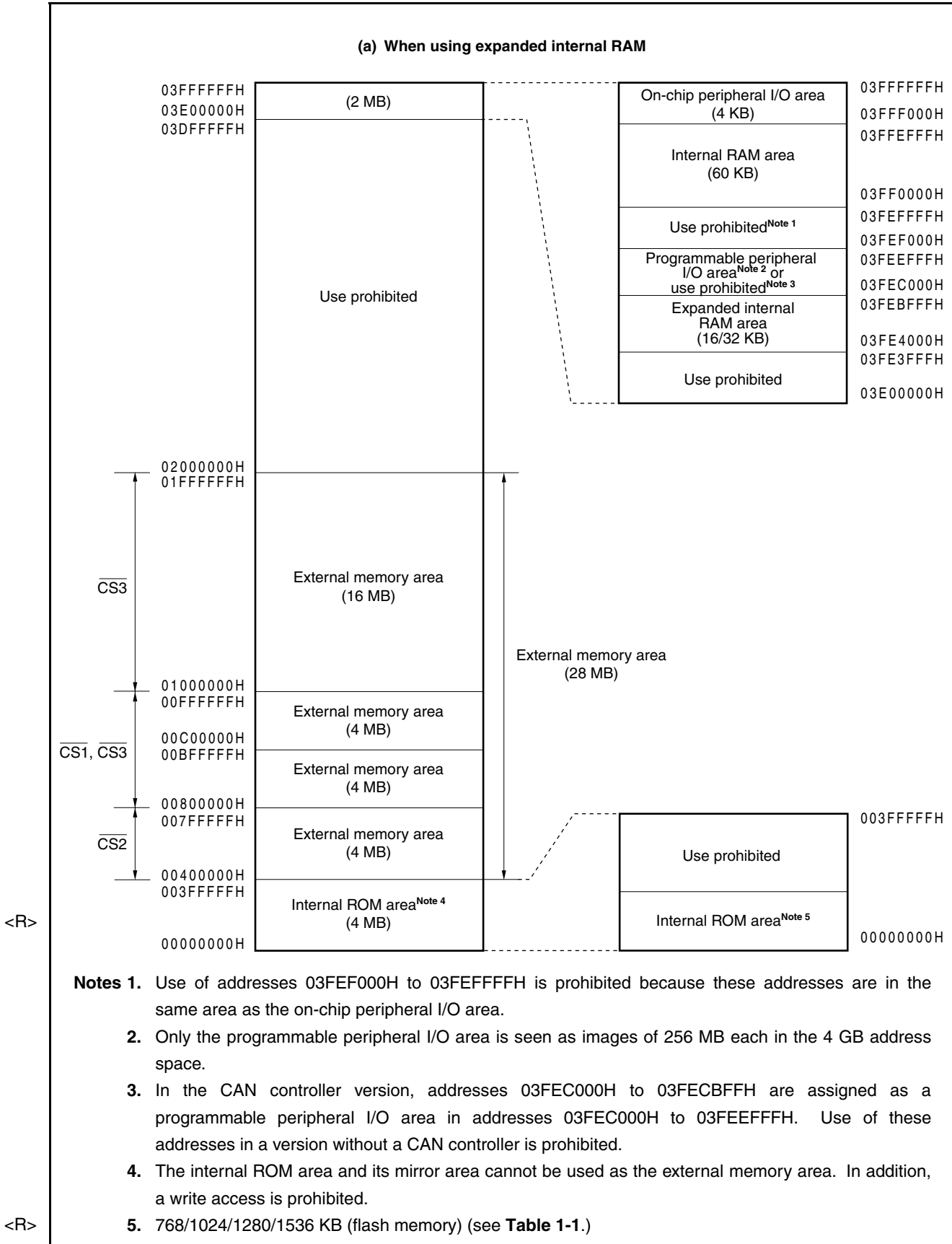
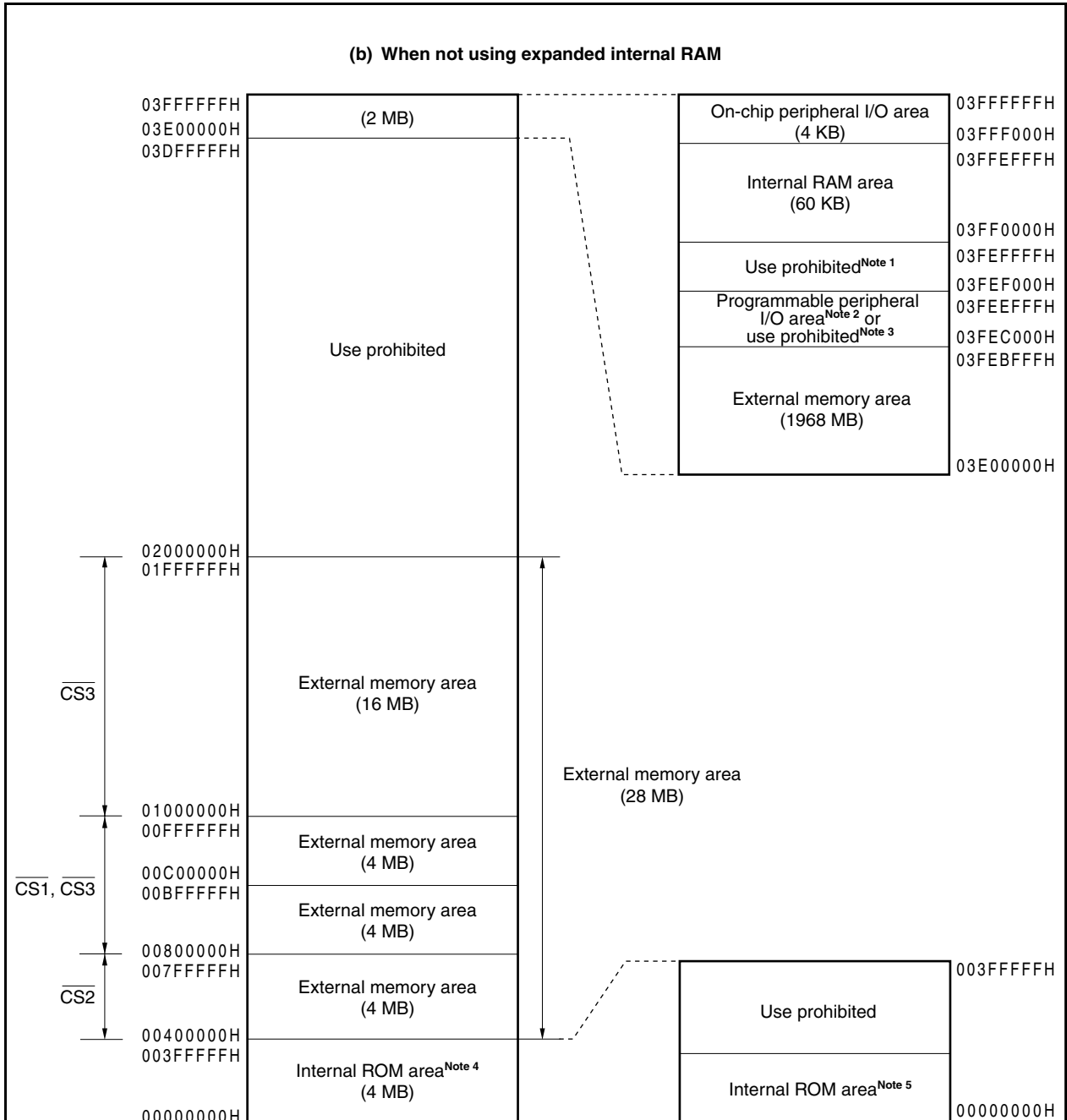



Figure 5-1. Data Memory Map: Physical Address (2/2)

<R>



- Notes 1.** Use of addresses 03FEF000H to 03FEFFFFH is prohibited because these addresses are in the same area as the on-chip peripheral I/O area.
- 2.** Only the programmable peripheral I/O area is seen as images of 256 MB each in the 4 GB address space.
- 3.** In the CAN controller version, addresses 03FEC000H to 03FEFFFFH are assigned as a programmable peripheral I/O area in addresses 03FEC000H to 03FECBFFH. Use of these addresses in a version without a CAN controller is prohibited.
- 4.** The internal ROM area and its mirror area cannot be used as the external memory area. In addition, a write access is prohibited.
- 5.** 512/768/1024/1280/1536 KB (flash memory) (see **Table 1-1.**)

### 5.3.1 Chip select control function

In the V850E/SJ3-H and V850E/SK3-H, eight types of memory maps can be selected by the CSC0 and CSC1 registers.

#### <R> (1) Chip area select control registers 0, 1 (CSC0 and CSC1)

Set the CSC0 and CSC1 registers to the following set values.

This register can be read/written in 16-bit units.

The address and initial value of CSC0 and CSC1 registers are as follows.

Register Name	Address	Initial Value
CSC0	FFFFFF060H	2C11H
CSC1	FFFFFF062H	2C11H

**Caution** Write to the CSC0 and CSC1 registers after reset, and then do not change the set values. Also, do not access an external memory area until the initial settings of the CSC0 and CSC1 registers are complete.

#### (a) When using expansion internal RAM (Other than $\mu$ PD70F3931 (V850E/SJ3-H), 70F3932 (V850E/SJ3-H), 70F3933 (V850E/SJ3-H))

The relation of the setting value of CSC0 and CSC1 registers and the memory map is as follow.

**Caution** In the  $\mu$ PD70F3931 (V850E/SJ3-H), 70F3932 (V850E/SJ3-H), and 70F3933 (V850E/SJ3-H), expanded internal RAM is not provided. Therefore, the setting shown in “5.3.1 (1) (a) When using expanded internal RAM” cannot be used. Be sure to use the setting shown in “5.3.1 (1) (b) When not using expanded internal RAM”.

CSC0 Register Set Value	CSC1 Register Set Value	Memory Map
2C11H (initial value)	2C11H (initial value)	Memory map 1 (see <1> in Figure 5-2)
ECC3H	2C11H (initial value)	Memory map 2 (see <2> in Figure 5-2)
2C83H	2C11H (initial value)	Memory map 3 (see <3> in Figure 5-2)
2C43H	2C11H (initial value)	Memory map 4 (see <4> in Figure 5-2)
Other than above	Other than above	Setting prohibited

Figure 5-2. Four Types of Memory Maps That Can Be Set by CSC0 and CSC1 Registers: When Using Expanded Internal RAM (1/2)

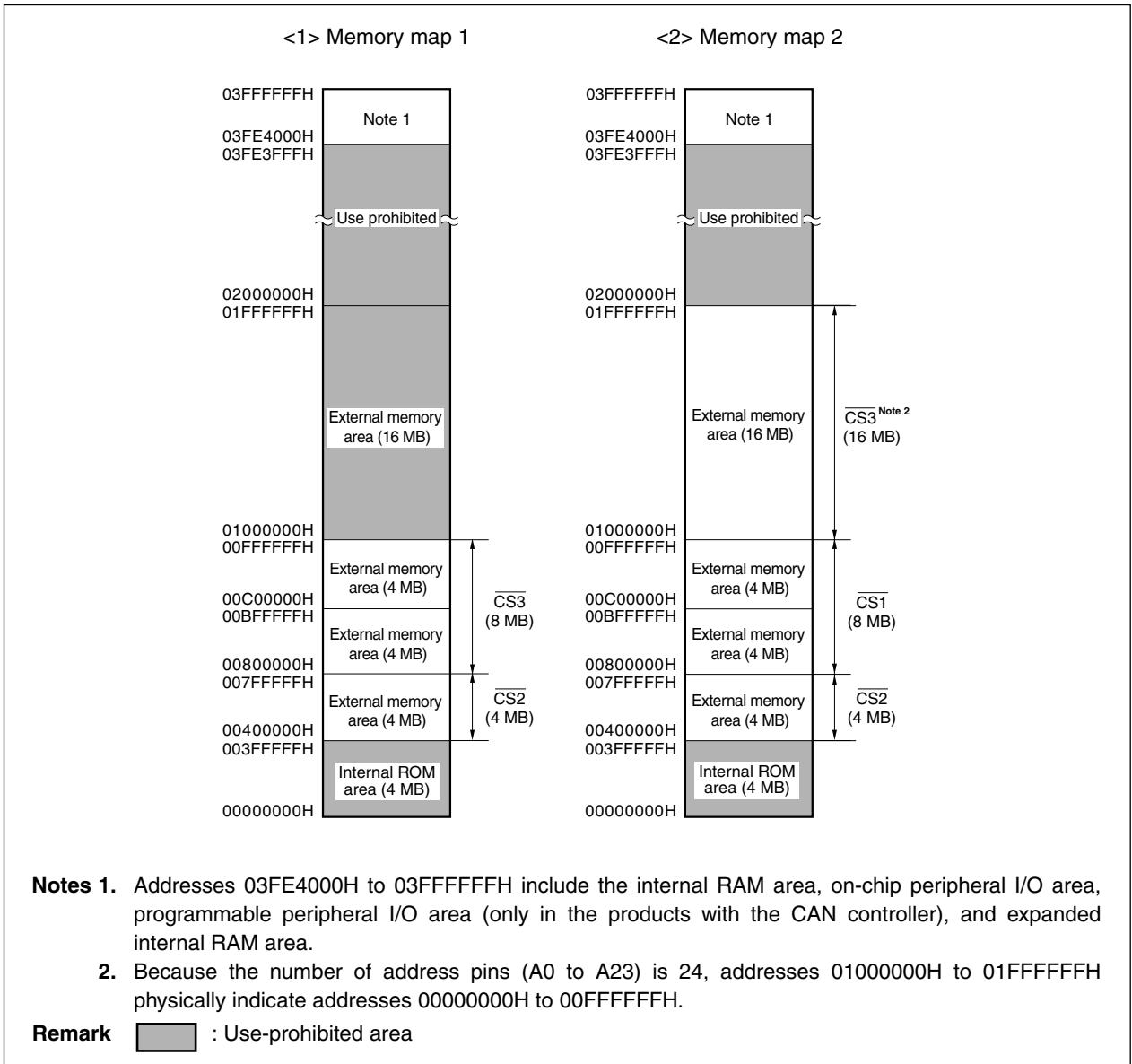
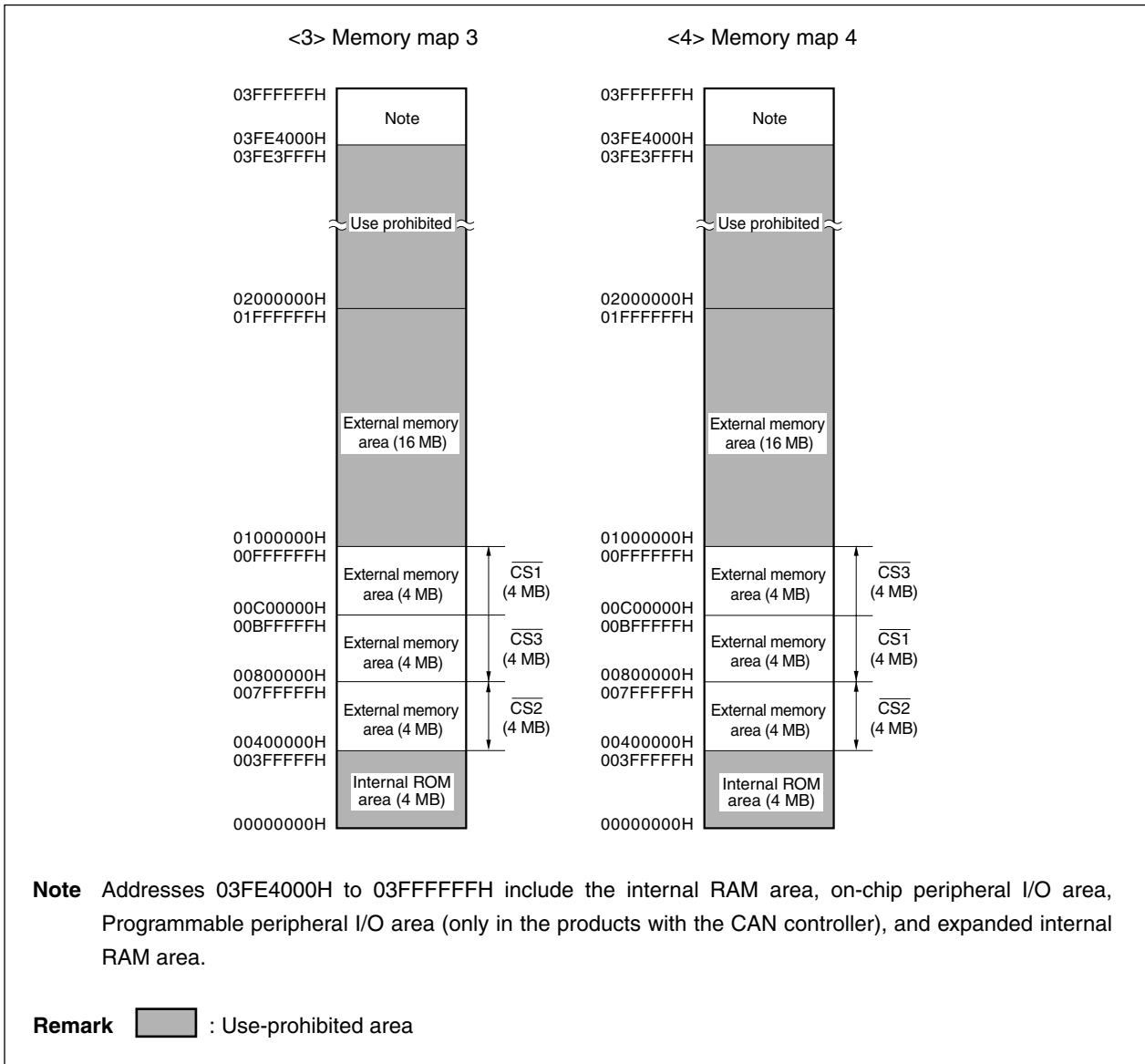

Figure 5-2. Four Types of Memory Maps That Can Be Set by CSC0 and CSC1 Registers: When Using Expanded Internal RAM (2/2)



**(b) When not using expanded internal RAM**

The relationship between the setting value of the CSC0 and CSC1 registers and the memory map is as follows.

CSC0 Register Set Value	CSC1 Register Set Value	Memory Map
2C11H (initial value)	0100H	Memory map 1 (see <1> in Figure 5-3)
ECC3H	0100H	Memory map 2 (see <2> in Figure 5-3)
2C83H	0100H	Memory map 3 (see <3> in Figure 5-3)
2C43H	0100H	Memory map 4 (see <4> in Figure 5-3)
Other than above	Other than above	Setting prohibited

**Figure 5-3. Four Types of Memory Maps That Can Be Set by CSC0 and CSC1 Registers: When Not Using Expanded Internal RAM (1/2)**

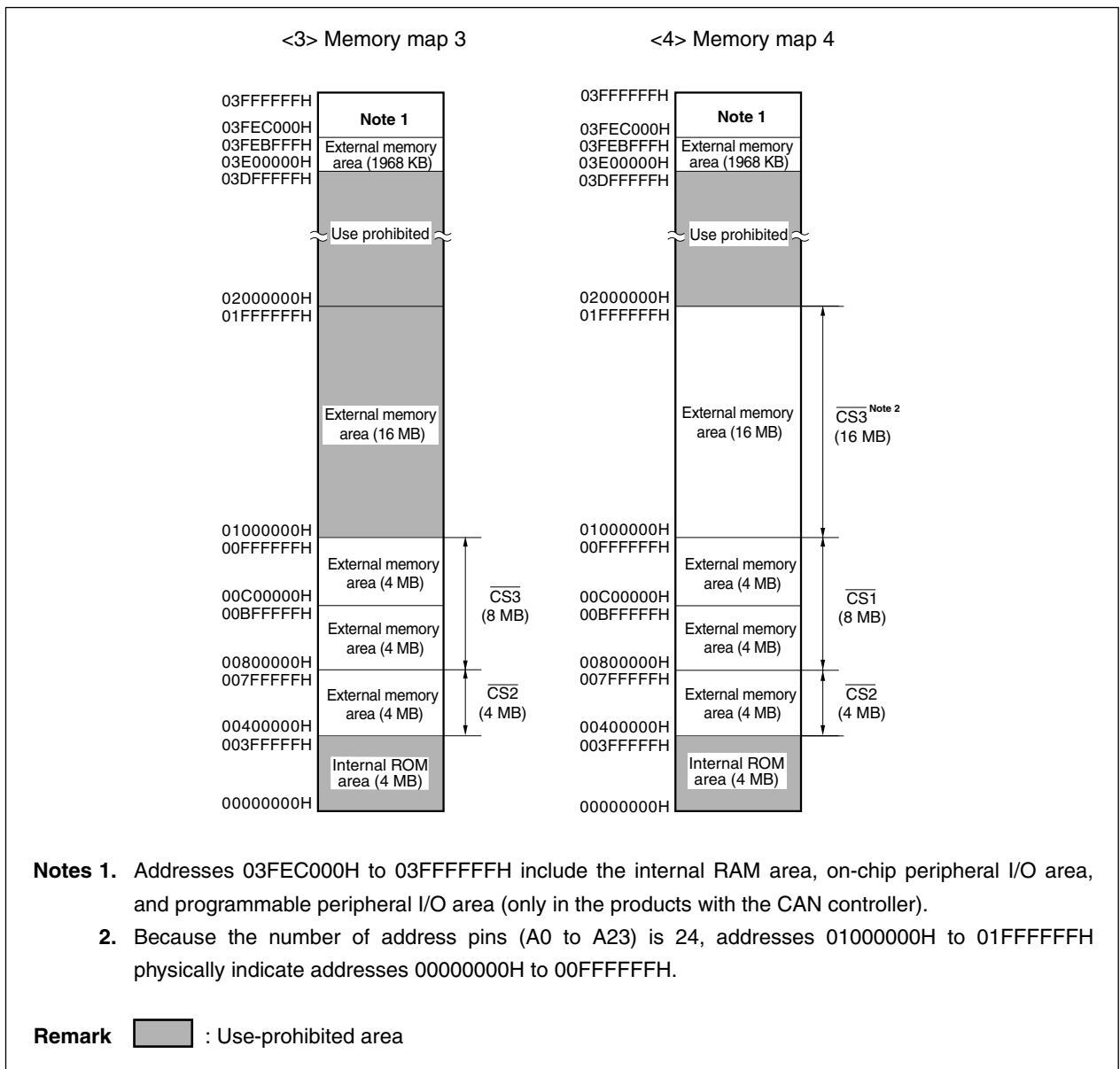
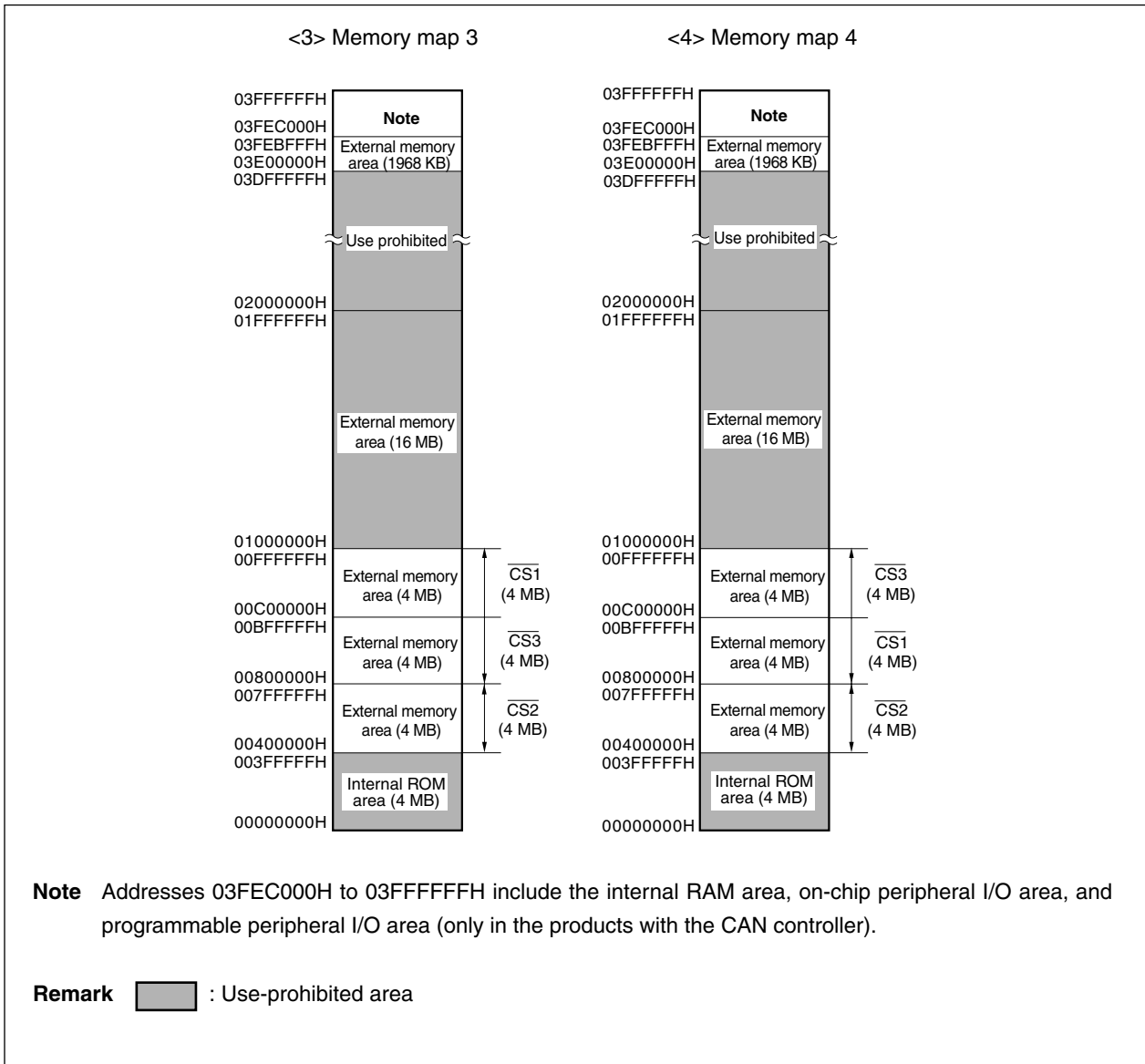

Figure 5-3. Four Types of Memory Maps That Can Be Set by CSC0 and CSC1 Registers: When Not Using Expanded Internal RAM (2/2)



### 5.4 External Bus Interface Mode Control Function

The V850E/SJ3-H and V850E/SK3-H include the following two external bus interface modes.

- Multiplexed bus mode
- Separate bus mode

These two modes can be selected by using the EXIMC register.

#### (1) External bus interface mode control register (EXIMC)

The EXIMC register can be read or written in 8-bit or 1-bit units.

Reset sets this register to 00H.

**Caution** Write to the EXIMC register after reset, and then do not change the set values. Also, do not access an external memory area until the initial settings of the EXIMC register are complete.

After reset: 00H	R/W	Address: FFFFFFFBEH
------------------	-----	---------------------

EXIMC	7	6	5	4	3	2	1	0
	0	0	0	0	0	0	0	SMSEL

SMSEL	Mode selection
0	Multiplexed bus mode
1	Separate bus mode

**Caution** Set the EXIMC register from the internal ROM or internal RAM area before making an external access.  
**After setting the EXIMC register, be sure to insert a NOP instruction.**

## 5.5 Bus Access

### 5.5.1 Number of clocks for access

The following table shows the number of basic clocks required for accessing each resource.

Area (Bus) Bus Cycle Type	Internal ROM (32 Bits)	Internal RAM (32 Bits)	External Memory (Multiplexed Bus) (16 Bits)	External Memory (Separate Bus) (16 Bits)	Expanded Internal RAM (32 Bits) <sup>Note 3</sup>
Instruction fetch (normal access)	1	1 <sup>Note 1</sup>	3 + n <sup>Note 2</sup>	2 + n <sup>Note 2</sup>	3 + n
Instruction fetch (branch)	3	2 <sup>Note 1</sup>	3 + n <sup>Note 2</sup>	2 + n <sup>Note 2</sup>	3 + n
Operand data access	4	1	3 + n <sup>Note 2</sup>	2 + n <sup>Note 2</sup>	3 + n

**Notes 1.** Incremented by 1 if a conflict with a data access occurs.

**2.** Data wait, address setup wait, address hold wait, and idle state are not included.

**3.** If the external bus is set in the multiplexed bus mode, the expanded internal RAM is accessed in the multiplexed bus access mode, if the external bus is set in the separate bus mode, the expanded internal RAM is accessed in the separate bus access mode.

**Remarks 1.** Unit: Clocks/access

**2.** n: Number of waits inserted by the  $\overline{\text{WAIT}}$  pin



**5.5.2 Bus size setting function**

Each external memory area selected by  $\overline{CSn}$  can be set by using the BSC register. However, the bus size can be set to 8 bits and 16 bits only.

The external memory area of the V850E/SJ3-H and V850E/SK3-H is selected by  $\overline{CS1}$  to  $\overline{CS3}$ .

**(1) Bus size configuration register (BSC)**

The BSC register can be read or written in 16-bit units.

Reset sets this register to 5555H.

**Caution** Write to the BSC register after reset, and then do not change the set values. Also, do not access an external memory area until the initial settings of the BSC register are complete.

After reset: 5555H    R/W    Address: FFFFF066H

	15	14	13	12	11	10	9	8
BSC	0/1	0/1	0/1	0/1	0/1	0/1	0/1	0/1
	7	6	5	4	3	2	1	0
	0	BS30	0	BS20	0	BS10	0/1	0/1
		$\overline{CS3}$		$\overline{CS2}$		$\overline{CS1}$		

<R>

Bits 15 to 8	Expanded internal RAM/external memory area setting
01010001	Expanded internal RAM is not used. External memory area (3E00000H to 3FEBFFFH, data bus width: 8 bits) is used.
01010101	Expanded internal RAM is not used. External memory area (3E00000H to 3FEBFFFH, data bus width: 16 bits) is used.
10010101 <sup>Note</sup>	Expanded internal RAM is used. External memory area (3E00000H to 3FEBFFFH) is not used.
Other than above	Setting prohibited

BSn0	Data bus width of CSn space (n = 1 to 3)
0	8 bits
1	16 bits

Bits 1 and 0	In-circuit emulator (IECUBE <sup>®</sup> ) setting
10	IECUBE is used.
Other than above	Setting prohibited

<R>

**Note** This setting is prohibited in the  $\mu$ PD70F3931 (V850E/SJ3-H), 70F3932 (V850E/SJ3-H), and 70F3933 (V850E/SJ3-H).

**Caution** Be sure to clear bits 7, 5, and 3 to "0".

### 5.5.3 Access by bus size

The V850E/SJ3-H and V850E/SK3-H access the on-chip peripheral I/O and external memory in 8-bit, 16-bit, or 32-bit units. The bus size is as follows.

- The bus size of the on-chip peripheral I/O is fixed to 16 bits.
- The bus size of the external memory is selectable from 8 bits or 16 bits (by using the BSC register).

The operation when each of the above is accessed is described below. All data is accessed starting from the lower side.

The V850E/SJ3-H and V850E/SK3-H support only the little-endian format.

**Figure 5-4. Little-Endian Address in Word**

31	24 23	16 15	8 7	0
000BH	000AH	0009H	0008H	
0007H	0006H	0005H	0004H	
0003H	0002H	0001H	0000H	

#### (1) Data space

The V850E/SJ3-H and V850E/SK3-H have an address misalign function.

With this function, data can be placed at all addresses, regardless of the format of the data (word data or halfword data). However, if the word data or halfword data is not aligned at the boundary, a bus cycle is generated at least twice, causing the bus efficiency to drop.

##### (a) Halfword-length data access

A byte-length bus cycle is generated twice if the least significant bit of the address is 1.

##### (b) Word-length data access

- (i) A byte-length bus cycle, halfword-length bus cycle, and byte-length bus cycle are generated in that order if the least significant bit of the address is 1.
- (ii) A halfword-length bus cycle is generated twice if the lower 2 bits of the address are 10.

(2) Byte access (8 bits)

(a) 16-bit data bus width

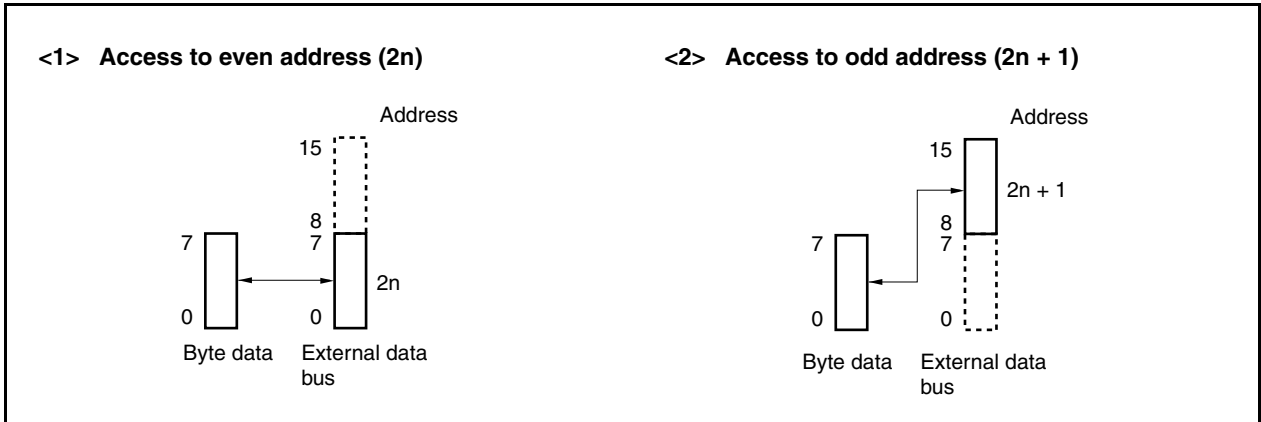

(b) 8-bit data bus width

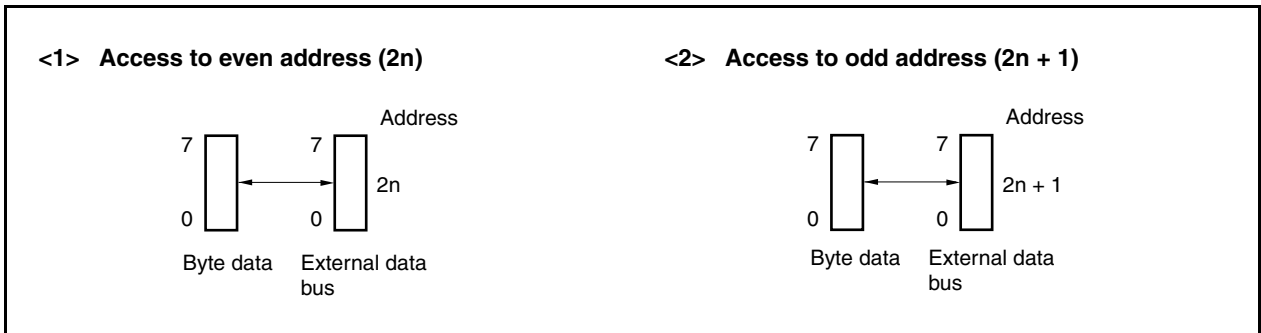

(3) Halfword access (16 bits)

(a) With 16-bit data bus width

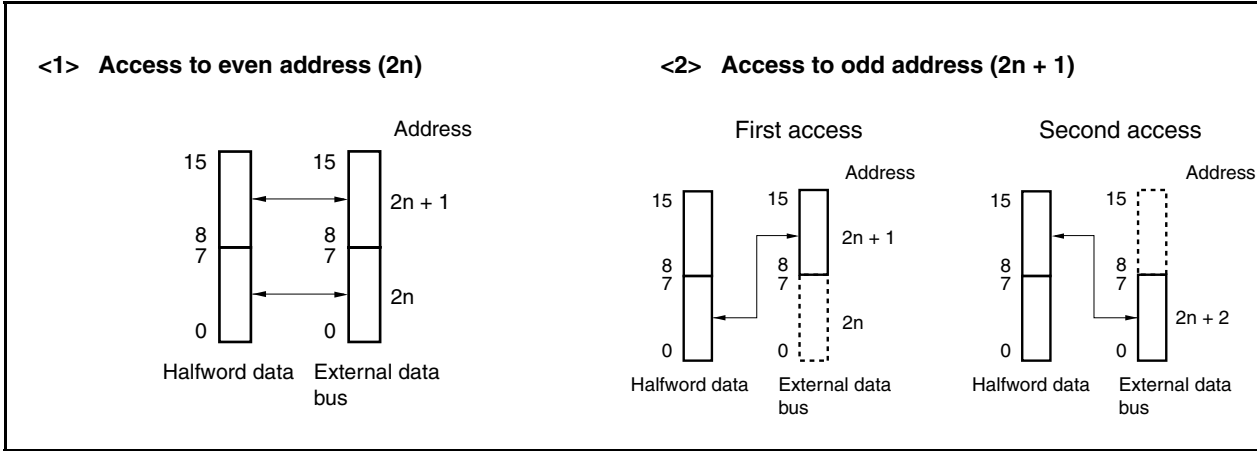

(b) 8-bit data bus width

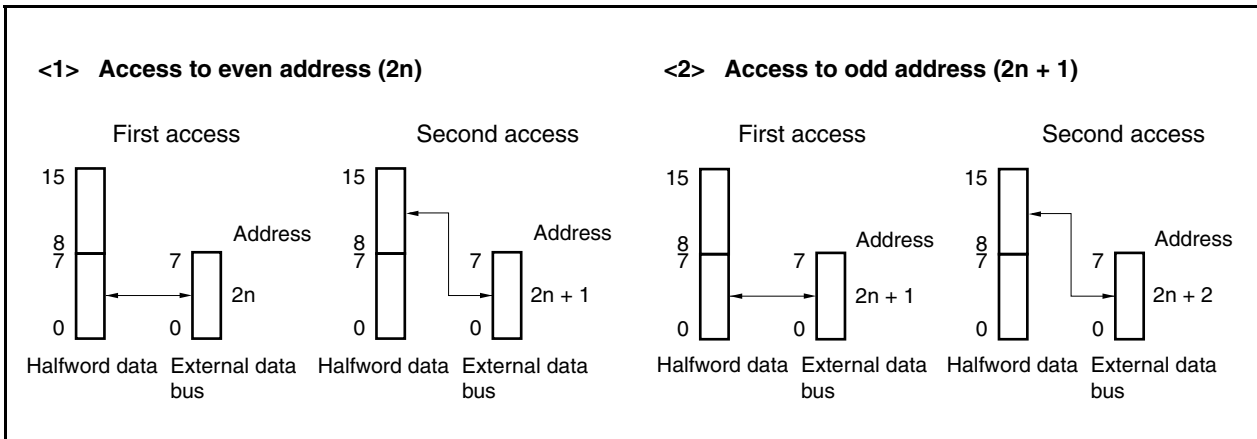

(4) Word access (32 bits)

(a) 16-bit data bus width (1/2)

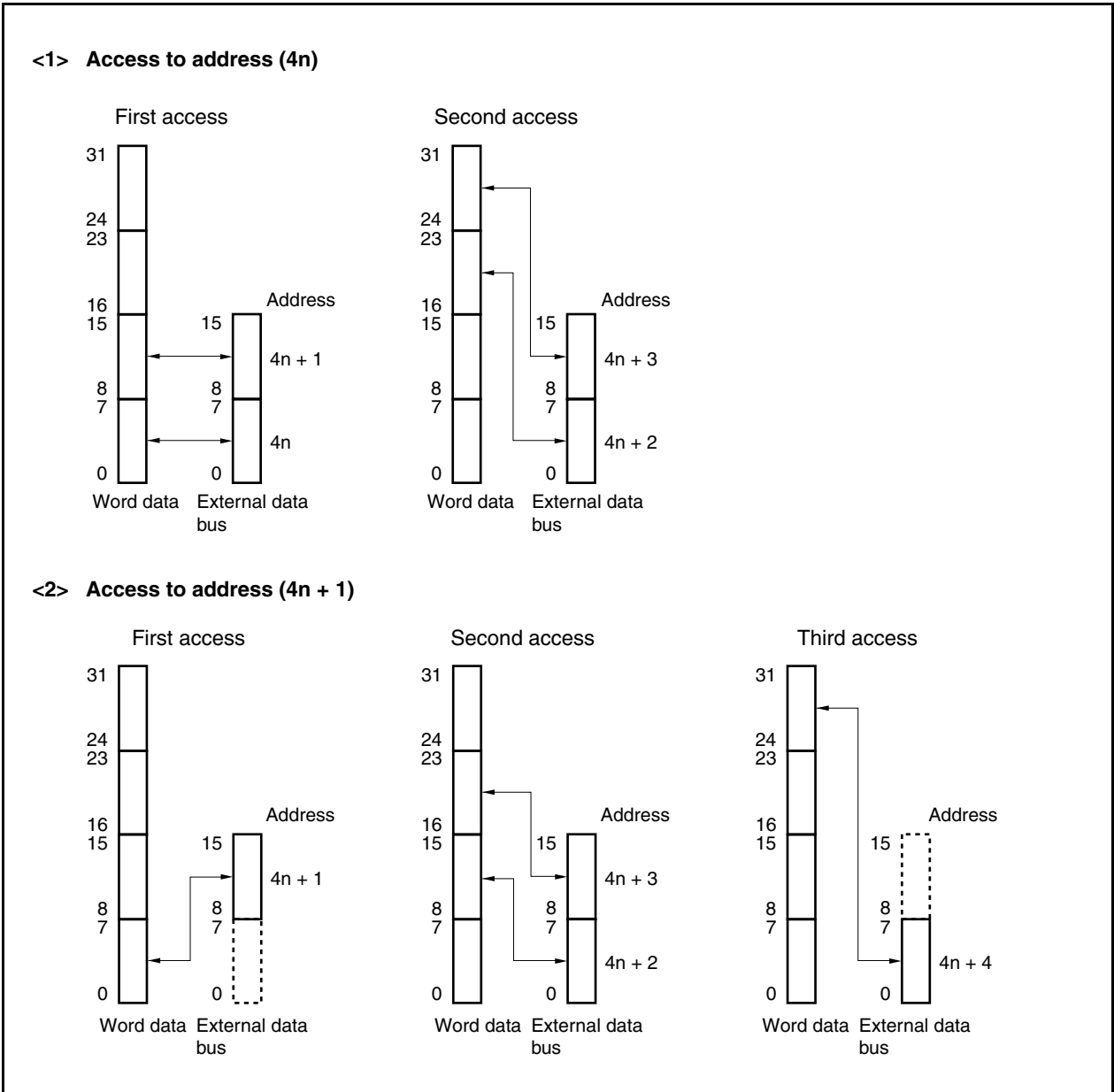

(a) 16-bit data bus width (2/2)

<3> Access to address (4n + 2)

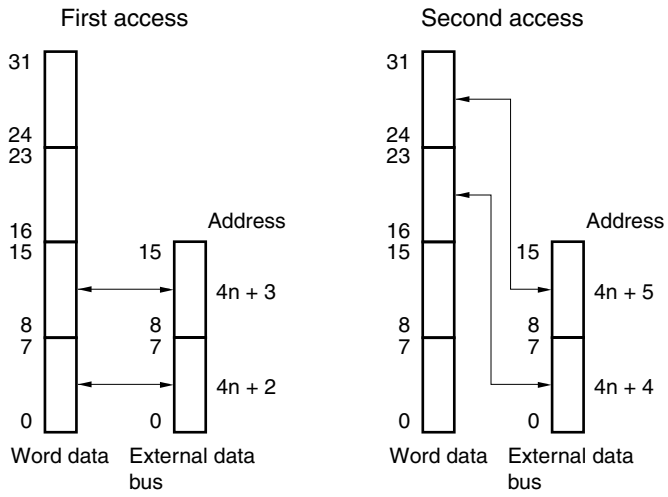

<4> Access to address (4n + 3)

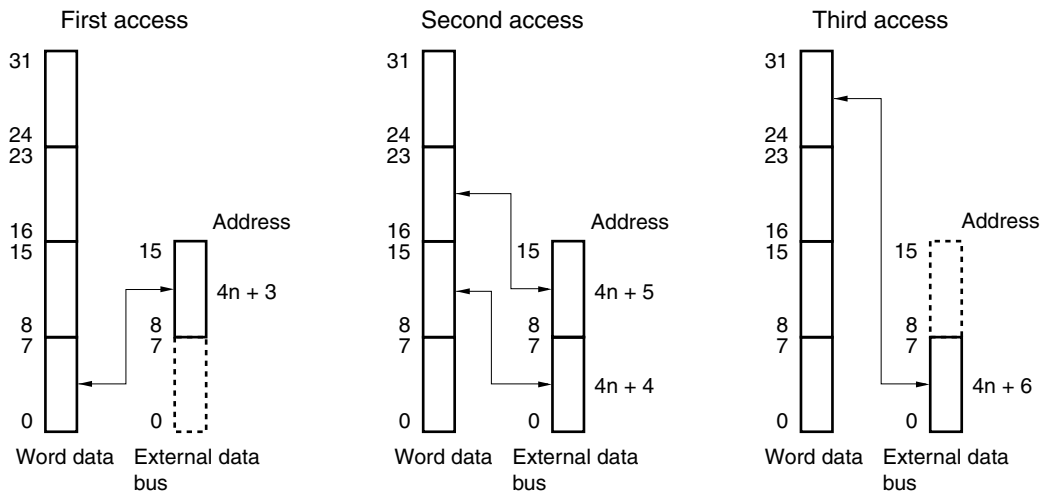

(b) 8-bit data bus width (1/2)

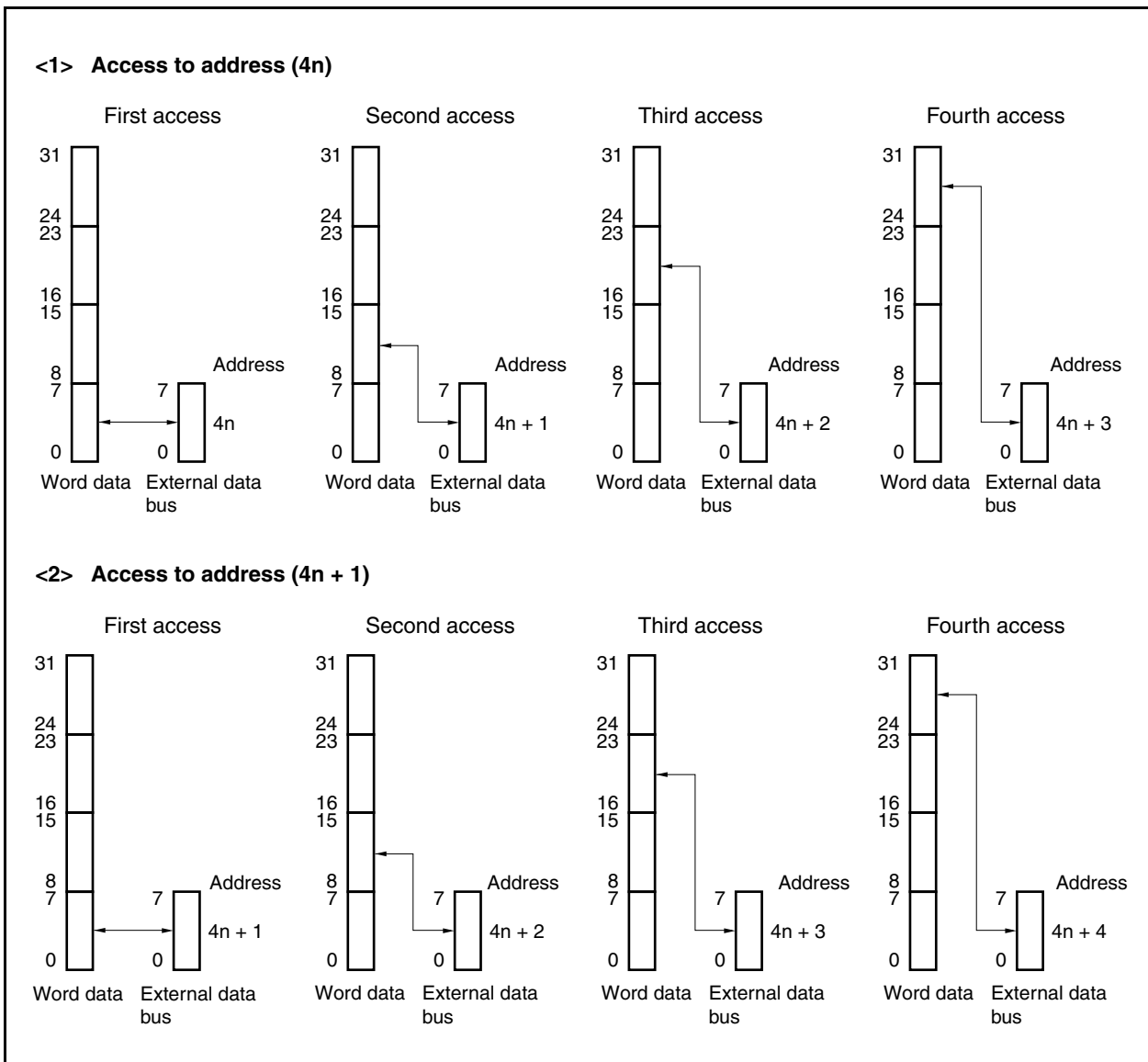

(b) 8-bit data bus width (2/2)

<3> Access to address (4n + 2)

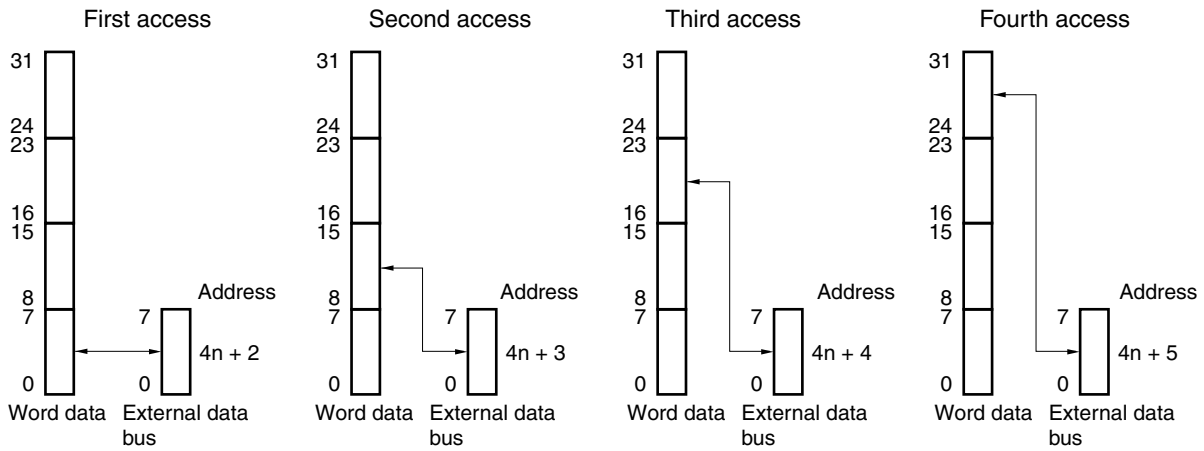

<4> Access to address (4n + 3)

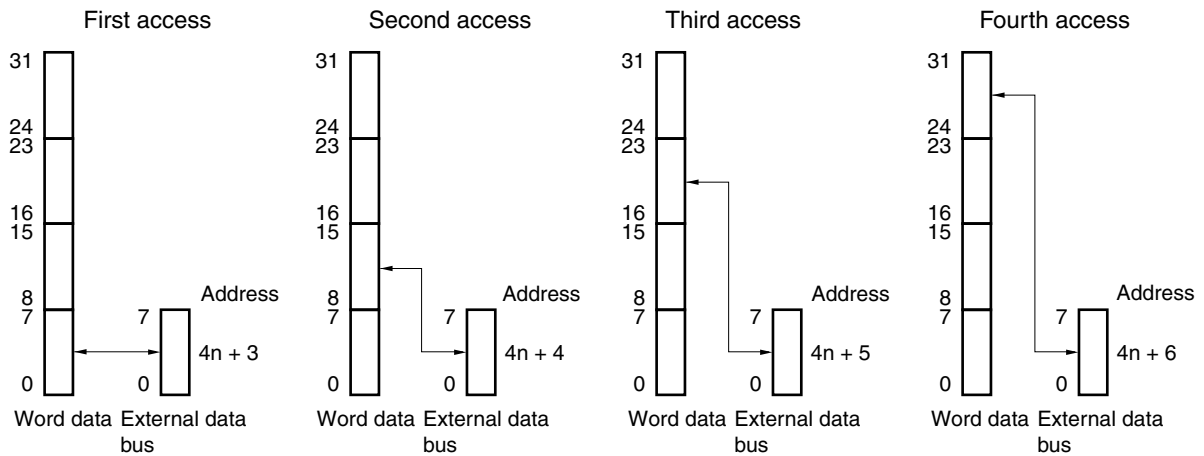



## 5.6 Wait Function

### 5.6.1 Programmable wait function

#### (1) Data wait control register 0 (DWC0)

To realize interfacing with a low-speed memory or I/O, up to seven data wait states can be inserted in the bus cycle that is executed for each CS space.

The number of wait states can be programmed by using the DWC0 register. Immediately after system reset, 7 data wait states are inserted for all the blocks.

The DWC0 register can be read or written in 16-bit units.

Reset sets this register to 7777H.

- Cautions**
- 1. The internal ROM and internal RAM areas are not subject to programmable wait, and are always accessed without a wait state. The on-chip peripheral I/O area is also not subject to programmable wait, and only wait control from each peripheral function is performed.**
  - 2. Write to the DWC0 register after reset, and then do not change the set values. Also, do not access an external memory area until the initial settings of the DWC0 register are complete.**
  - 3. When the V850E/SJ3-H and V850E/SK3-H are used in separate bus mode and operated at  $f_{CPU} > 20$  MHz, be sure to insert one or more wait.**
  - 4. When the V850E/SJ3-H and V850E/SK3-H are used in multiplexed bus mode and operated at  $f_{CPU} > 32$  MHz, be sure to insert one or more wait.**

After reset: 7777H    R/W    Address: FFFFF484H

	15	14	13	12	11	10	9	8
DWC0	0	DW32	DW31	DW30	0	DW22	DW21	DW20
	$\overline{\text{CS3}}$			$\overline{\text{CS2}}$				
	7	6	5	4	3	2	1	0
	0	DW12	DW11	DW10	0	0/1	0/1	0/1
	$\overline{\text{CS1}}$							

DWn2	DWn1	DWn0	Number of wait states inserted in CSn space (n = 1 to 3)			
			Multiplexed bus		Separate bus	
			f <sub>CPU</sub> ≤ 32 MHz	f <sub>CPU</sub> > 32 MHz	f <sub>CPU</sub> ≤ 20 MHz	f <sub>CPU</sub> > 20 MHz
0	0	0	None	Setting prohibited	None	Setting prohibited
0	0	1	1			
0	1	0	2			
0	1	1	3			
1	0	0	4			
1	0	1	5			
1	1	0	6			
1	1	1	7			

Bits 2 to 0	In-circuit emulator (IECUBE) setting
001	IECUBE is used when EXIMC register = 01H and f <sub>CPU</sub> > 32 MHz.
000	IECUBE is used when other than above.
Other than above	Setting prohibited

**Caution** Be sure to clear bits 15, 11, 7, and 3 to "0".

**(2) Data wait control register 1 (DWC1)**

The DWC1 register can be read or written in 16-bit units (address: FFFFF486H, initial value: 7777H).

<R> **(a) When using the expanded internal RAM (does not apply to the  $\mu$ PD70F3931 (V850E/SJ3-H), 70F3932 (V850E/SJ3-H), and 70F3933 (V850E/SJ3-H))**

Be sure to set the DWC1 register to the following value by setting the EXIMC register.

<R> **Caution** In the  $\mu$ PD70F3931 (V850E/SJ3-H), 70F3932 (V850E/SJ3-H), and 70F3933 (V850E/SJ3-H), expanded internal RAM is not provided. Therefore, the setting shown in "5.6.1 (2) (a) When using expanded internal RAM" cannot be used. Be sure to use the setting shown in "5.6.1 (2) (b) Not using expansion internal RAM".

EXIMC Register Set Value	DWC1 Register Set Value
00H (Multiplexed bus mode)	0777H
01H (Separate bus mode)	1777H

<R>

**(b) When not using the expanded internal RAM**

To realize interfacing with a low-speed memory or I/O, up to seven data wait states can be inserted in the bus cycle that is executed for each external memory area (3E00000H to 3FEBFFFH).

The number of wait states can be programmed by using the DWC1 register. Immediately after system reset, 7 data wait states are inserted.

- Cautions**
1. Write to the DWC1 register after reset, and then do not change the set values. Also, do not access an external memory area until the initial settings of the DWC1 register are complete.
  2. When the V850E/SJ3-H and V850E/SK3-H are used in separate bus mode and operated at  $f_{CPU} > 20$  MHz, be sure to insert one or more wait.
  3. When the V850E/SJ3-H and V850E/SK3-H are used in multiplexed bus mode and operated at  $f_{CPU} > 32$  MHz, be sure to insert one or more wait.

After reset: 7777H		R/W	Address: FFFFF486H					
	15	14	13	12	11	10	9	8
DWC1	0	1	1	1	0	1	1	1
	7	6	5	4	3	2	1	0
	0	0/1	0/1	0/1	0	1	1	1

Bits 7 to 0	Number of wait states inserted in external memory area (3E00000H to 3FEBFFFH)			
	Multiplexed bus		Separate bus	
	$f_{CPU} \leq 32$ MHz	$f_{CPU} > 32$ MHz	$f_{CPU} \leq 20$ MHz	$f_{CPU} > 20$ MHz
00000111	None	Setting prohibited	None	Setting prohibited
00010111	1			
00100111	2			
00110111	3			
01000111	4			
01010111	5			
01100111	6			
01110111	7			

**Caution** Be sure to clear bits 15, 11, 7, and 3 to “0”, and set bits 14 to 12, 10 to 8, and 2 to 0 to “1”.

### 5.6.2 External wait function

To synchronize an extremely slow external memory, I/O, or asynchronous system, any number of wait states can be inserted in the bus cycle by using the external wait pin ( $\overline{\text{WAIT}}$ ).

When the PCMO pin is set to alternate function, the external wait function is enabled.

Access to each area of the internal ROM, internal RAM, and on-chip peripheral I/O is not subject to control by the external wait function, in the same manner as the programmable wait function.

Access to the expanded internal RAM area is controlled by the external wait function.

The  $\overline{\text{WAIT}}$  signal can be input asynchronously to CLKOUT, and is sampled at the falling edge of the clock in the T2 and TW states of the bus cycle in the multiplexed bus mode. In the separate bus mode, it is sampled at the rising edge of the clock immediately after the T1 and TW states of the bus cycle. If the setup/hold time of the sampling timing is not satisfied, a wait state is inserted in the next state, or not inserted at all.

5.6.3 Relationship between programmable wait and external wait

Wait cycles are inserted as the result of an OR operation between the wait cycles specified by the set value of the programmable wait and the wait cycles controlled by the  $\overline{\text{WAIT}}$  pin.

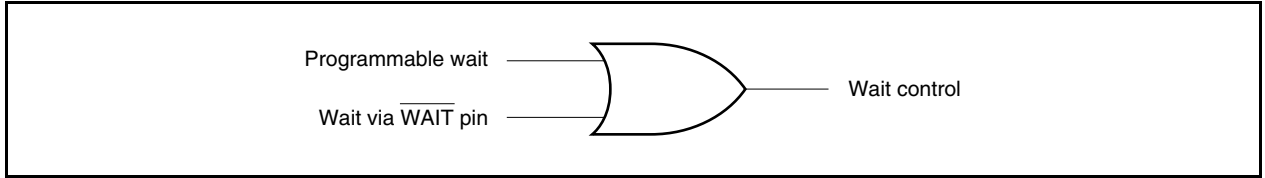

For example, if the timing of the programmable wait and the  $\overline{\text{WAIT}}$  pin signal is as illustrated below, three wait states will be inserted in the bus cycle.

Figure 5-5. Inserting Wait Example

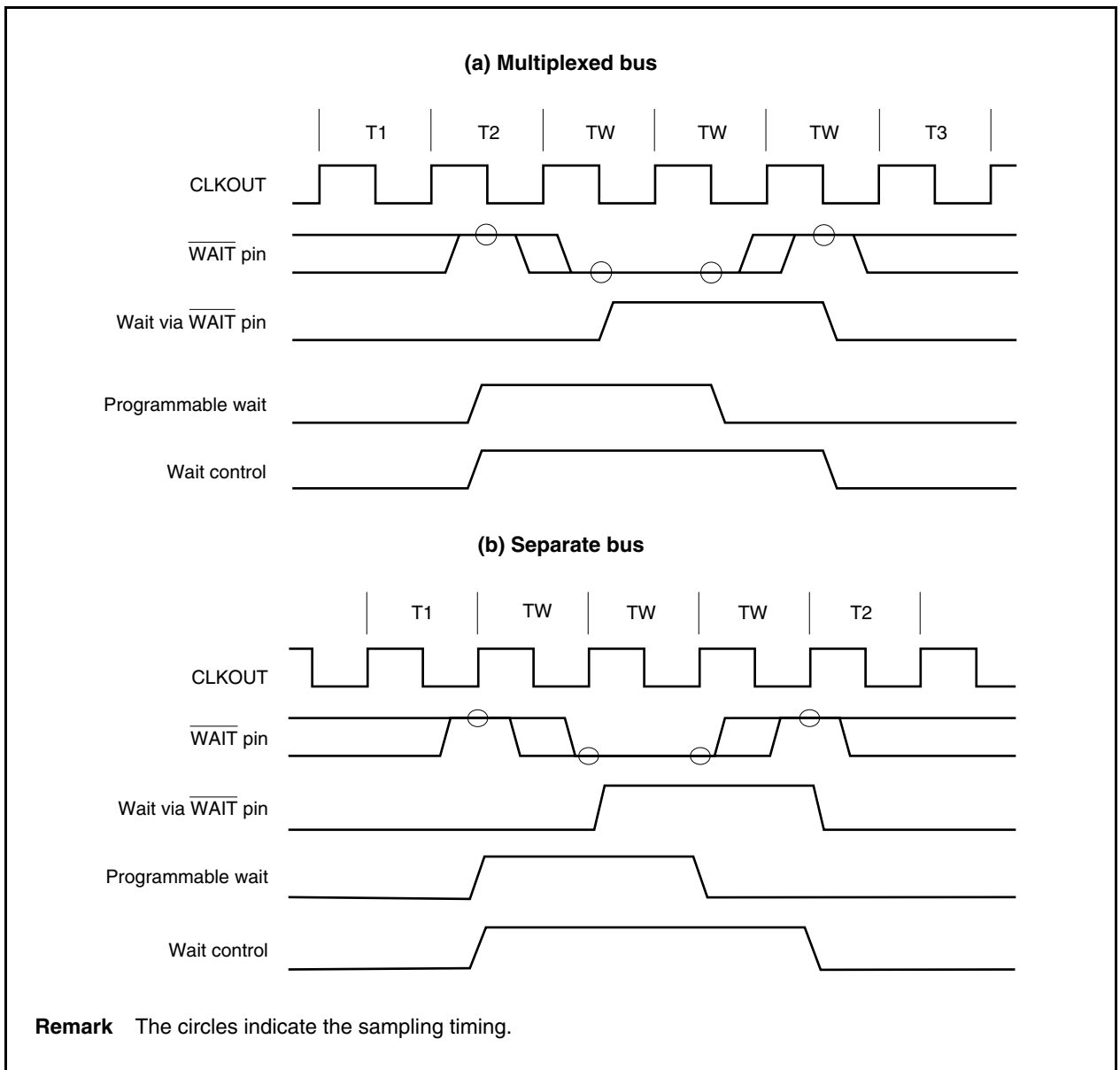

#### 5.6.4 Programmable address wait function

Address-setup (ASW) or address-hold waits (AHW) to be inserted in each bus cycle can be set by using the AWC register. Address wait insertion is set for each chip select area ( $\overline{CS1}$  to  $\overline{CS3}$ ).

If an address setup wait is inserted, it seems that the high-clock period of the T1 state is extended by 1 clock. If an address hold wait is inserted, it seems that the low-clock period of the T1 state is extended by 1 clock.

##### (1) Address wait control register (AWC)

The AWC register can be read or written in 16-bit units.

Reset sets this register to FFFFH.

- Cautions**
1. Address setup wait and address hold wait cycles are not inserted when the internal ROM area, internal RAM area, and on-chip peripheral I/O areas are accessed.
  2. Write to the AWC register after reset, and then do not change the set values. Also, do not access an external memory area until the initial settings of the AWC register are complete.
  3. When the V850E/SJ3-H and V850E/SK3-H are operated at  $f_{CPU} > 20$  MHz, be sure to insert the address hold wait and the address setup wait.

After reset: FFFFH R/W Address: FFFF488H

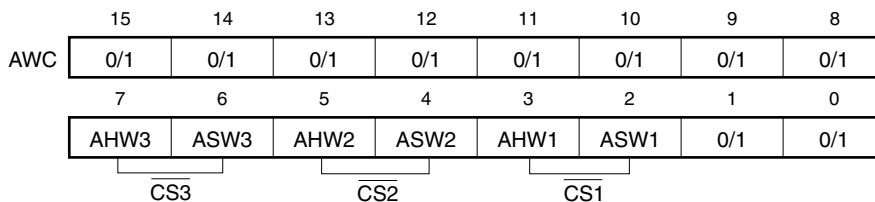

<R>

Bits 15 to 8	Expanded internal RAM/external memory area setting
00111111 <sup>Note</sup>	Expanded internal RAM is used. External memory area (3E00000H to 3FEBFFFH) is not used.
11110011	Expanded internal RAM is not used. External memory area (3E00000H to 3FEBFFFH, AHW and ASW are not inserted (setting prohibited when $f_{CPU} > 20$ MHz)) is used.
11110111	Expanded internal RAM is not used. External memory area (3E00000H to 3FEBFFFH, AHW is not inserted (setting prohibited when $f_{CPU} > 20$ MHz), ASW is inserted) is used.
11111011	Expanded internal RAM is not used. External memory area (3E00000H to 3FEBFFFH, AHW is inserted, ASW is not inserted (setting prohibited when $f_{CPU} > 20$ MHz)) is used.
11111111	Expanded internal RAM is not used. External memory area (3E00000H to 3FEBFFFH, AHW and ASW are inserted) is used.
Other than above	Setting prohibited

AHWn	Specifies insertion of address hold wait (n = 1 to 3)	
	$f_{CPU} \leq 20$ MHz	$f_{CPU} > 20$ MHz
0	Not inserted	Setting prohibited
1	Inserted	Inserted

ASWn	Specifies insertion of address setup wait (n = 1 to 3)	
	$f_{CPU} \leq 20$ MHz	$f_{CPU} > 20$ MHz
0	Not inserted	Setting prohibited
1	Inserted	Inserted

Bits 1 and 0	In-circuit emulator (IECUBE) setting
00	IECUBE is used.
Other than above	Setting prohibited

<R>

**Note** This setting is prohibited in the  $\mu$ PD70F3931 (V850E/SJ3-H), 70F3932 (V850E/SJ3-H), and 70F3933 (V850E/SJ3-H).

### 5.7 Idle State Insertion Function

To facilitate interfacing with low-speed memories, one idle state (TI) can be inserted after the T3 state in the bus cycle that is executed for each space selected by the chip select function in the multiplex address/data bus mode. In the separate bus mode, one idle state (TI) can be inserted after the T2 state. By inserting an idle state, the data output float delay time of the memory can be secured during read access (an idle state cannot be inserted during write access).

Whether the idle state is to be inserted can be programmed by using the BCC register.

An idle state is inserted for all the areas immediately after system reset.

#### (1) Bus cycle control register (BCC)

The BCC register can be read or written in 16-bit units.

Reset sets this register to AAAAH.

- Cautions**
1. The internal ROM, internal RAM, and on-chip peripheral I/O areas are not subject to idle state insertion.
  2. Write to the BCC register after reset, and then do not change the set values. Also, do not access an external memory area until the initial settings of the BCC register are complete.

After reset: AAAAH    R/W    Address: FFFFF48AH

	15	14	13	12	11	10	9	8
BCC	0/1	0/1	0/1	0/1	0/1	0/1	0/1	0/1
	7	6	5	4	3	2	1	0
	BC31	0	BC21	0	BC11	0	0/1	0
	<input type="checkbox"/>		<input type="checkbox"/>		<input type="checkbox"/>			
	CS3		CS2		CS1			

<R>

Bits 15 to 8	Expanded internal RAM/external memory area setting
00101010 <sup>Note</sup>	Expanded internal RAM is used. External memory area (3E00000H to 3FEBFFFH) is not used.
10100010	Expanded internal RAM is not used. External memory area (3E00000H to 3FEBFFFH, TI is not inserted) is used.
10101010	Expanded internal RAM is not used. External memory area (3E00000H to 3FEBFFFH, TI is inserted) is used.
Other than above	Setting prohibited

BCn1	Specifies insertion of idle state (n = 1 to 3)
0	Not inserted
1	Inserted

Bit 1	In-circuit emulator (IECUBE) setting
0	IECUBE is used.
1	Setting prohibited

<R>

**Note** This setting is prohibited in the  $\mu$ PD70F3931 (V850E/SJ3-H), 70F3932 (V850E/SJ3-H), and 70F3933 (V850E/SJ3-H).

**Caution** Be sure to clear bits 6, 4, 2, and 0 to "0".



## 5.8 Bus Hold Function

### 5.8.1 Functional outline

The  $\overline{\text{HLDRQ}}$  and  $\overline{\text{HLDAK}}$  functions are valid if the PCM2 and PCM3 pins are set to alternate function.

When the  $\overline{\text{HLDRQ}}$  pin is asserted (low level), indicating that another bus master has requested bus mastership, the external address/data bus goes into a high-impedance state and is released (bus hold status). If the request for the bus mastership is cleared and the  $\overline{\text{HLDRQ}}$  pin is deasserted (high level), driving these pins is started again.

During the bus hold period, execution of the program in the internal ROM and internal RAM is continued until an on-chip peripheral I/O register or the external memory is accessed.

The bus hold status is indicated by assertion of the  $\overline{\text{HLDAK}}$  pin (low level). The bus hold function enables the configuration of multi-processor type systems in which two or more bus masters exist.

Note that the bus hold request is not acknowledged during a multiple-access cycle initiated by the bus sizing function or a bit manipulation instruction.

Status	Data Bus Width	Access Type	Timing at Which Bus Hold Request Is Not Acknowledged	
CPU bus lock	16 bits	Word access to even address	Between first and second access	
		Word access to odd address	Between first and second access Between second and third access	
		Halfword access to odd address	Between first and second access	
	8 bits	Word access		Between first and second access Between second and third access Between third and fourth access
			Halfword access	Between first and second access
Read-modify-write access of bit manipulation instruction	–	–	Between read access and write access	

### 5.8.2 Bus hold procedure

The bus hold status transition procedure is shown below.

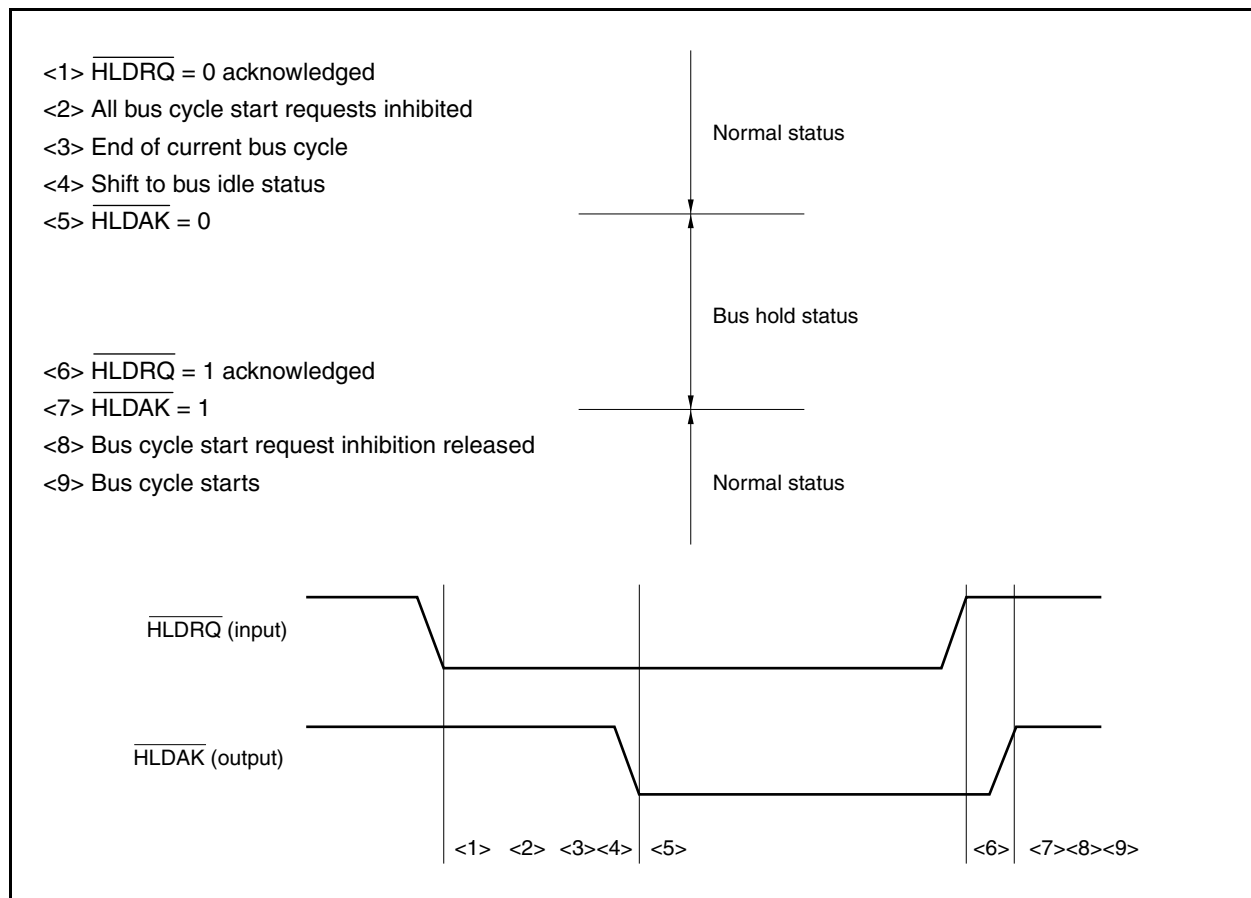

### 5.8.3 Operation in power save mode

Because the internal system clock is stopped in the STOP, IDLE1, IDLE2, and sub-IDLE modes, the bus hold status is not entered even if the  $\overline{\text{HLDARQ}}$  pin is asserted.

In the HALT mode, the  $\overline{\text{HLDAR}}$  pin is asserted as soon as the  $\overline{\text{HLDARQ}}$  pin has been asserted, and the bus hold status is entered. When the  $\overline{\text{HLDARQ}}$  pin is later deasserted, the  $\overline{\text{HLDAR}}$  pin is also deasserted, and the bus hold status is cleared.

## 5.9 Bus Priority

Bus hold, DMA transfer, operand data accesses, instruction fetch (branch), and instruction fetch (successive) are executed in the external bus cycle.

Bus hold has the highest priority, followed by DMA transfer, operand data access, instruction fetch (branch), and instruction fetch (successive).

An instruction fetch may be inserted between the read access and write access in a read-modify-write access.

If an instruction is executed for two or more accesses, an instruction fetch and bus hold are not inserted between accesses due to bus size limitations.

**Table 5-3. Bus Priority**

Priority	External Bus Cycle	Bus Master
High ↑ ↓ Low	Bus hold	External device
	DMA transfer	DMAC
	Operand data access	CPU
	Instruction fetch (branch)	CPU
	Instruction fetch (successive)	CPU

5.10 Bus Timing

Figure 5-6. Multiplexed Bus Read Timing (Bus Size: 16 Bits, 16-Bit Access)

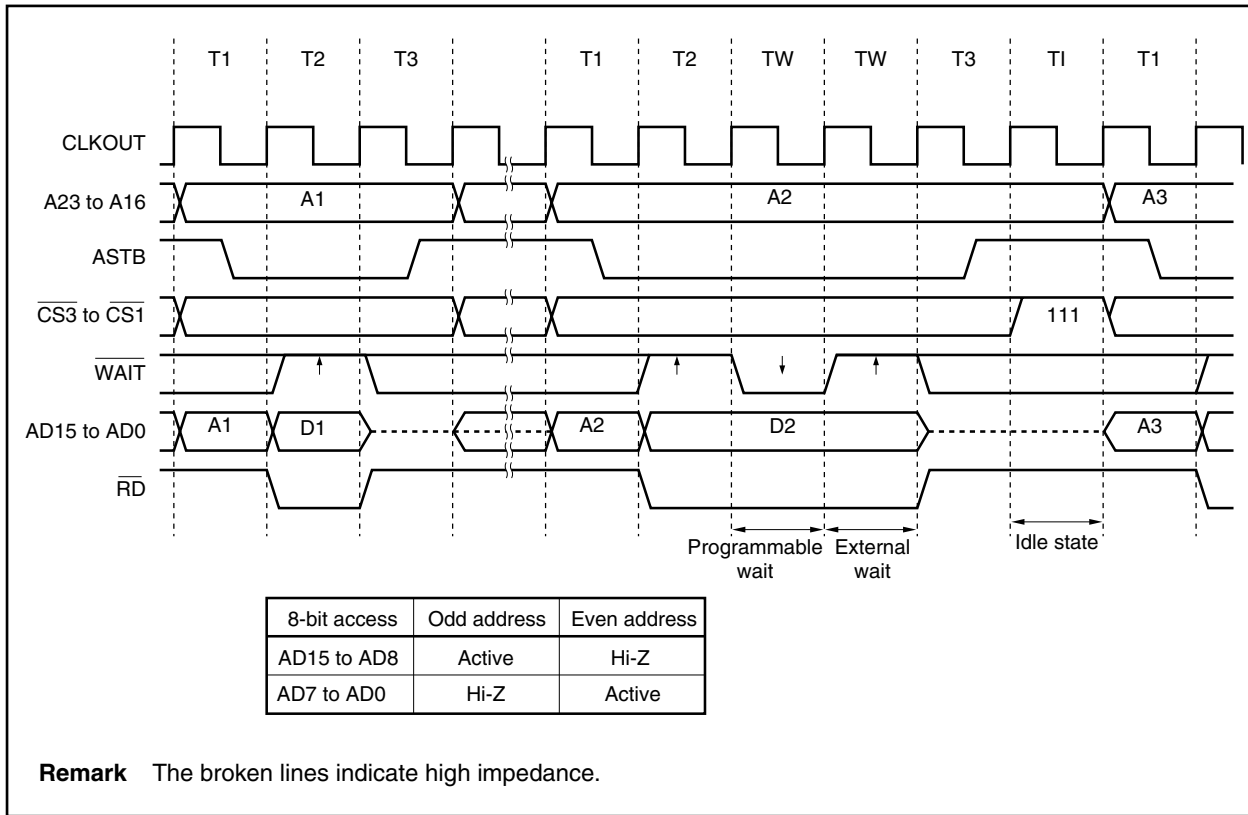

Figure 5-7. Multiplexed Bus Read Timing (Bus Size: 8 Bits)

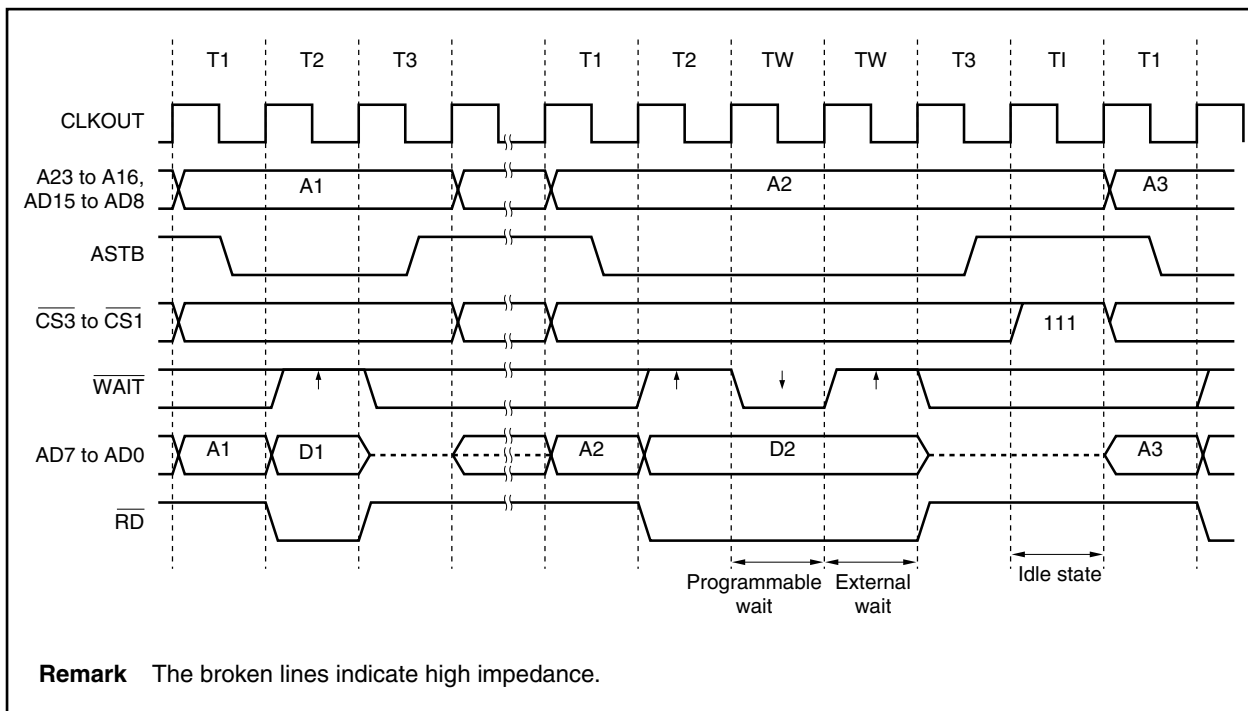

Figure 5-8. Multiplexed Bus Write Timing (Bus Size: 16 Bits, 16-Bit Access)

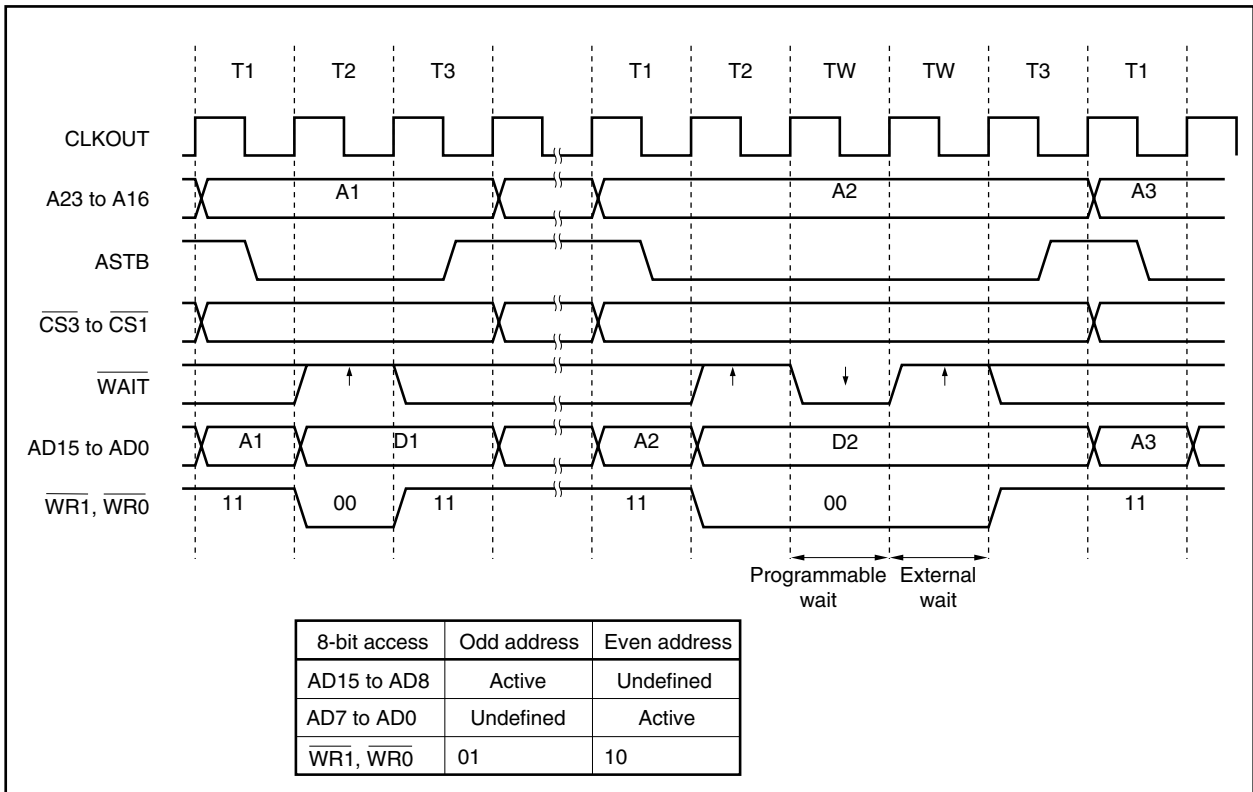

Figure 5-9. Multiplexed Bus Write Timing (Bus Size: 8 Bits)

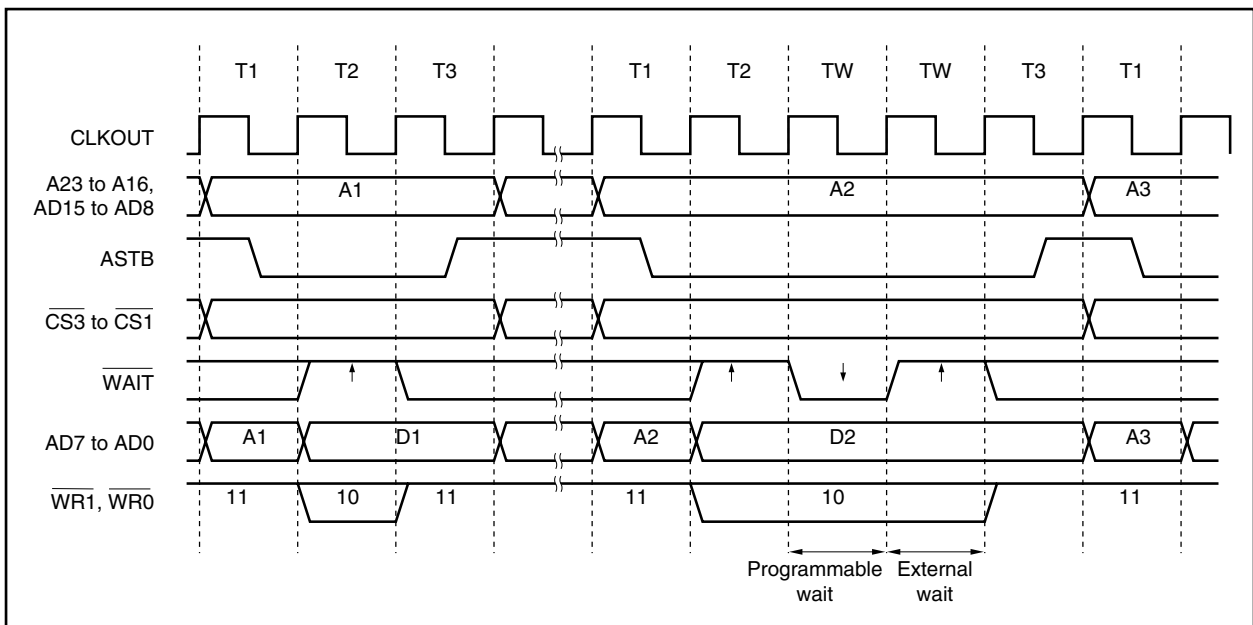
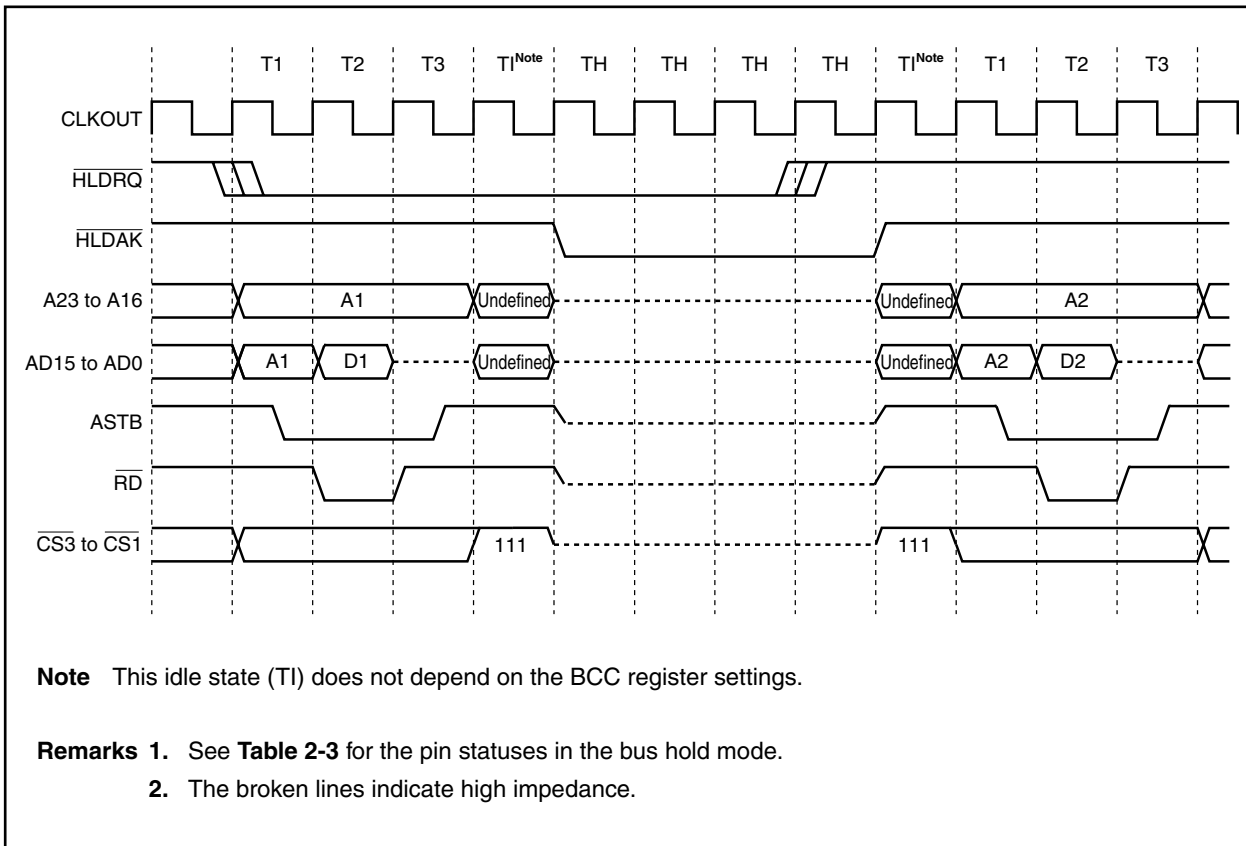

Figure 5-10. Multiplexed Bus Hold Timing (Bus Size: 16 Bits, 16-Bit Access)



**Note** This idle state (TI) does not depend on the BCC register settings.

- Remarks**
1. See **Table 2-3** for the pin statuses in the bus hold mode.
  2. The broken lines indicate high impedance.

Figure 5-11. Separate Bus Read Timing (Bus Size: 16 Bits, 16-Bit Access)

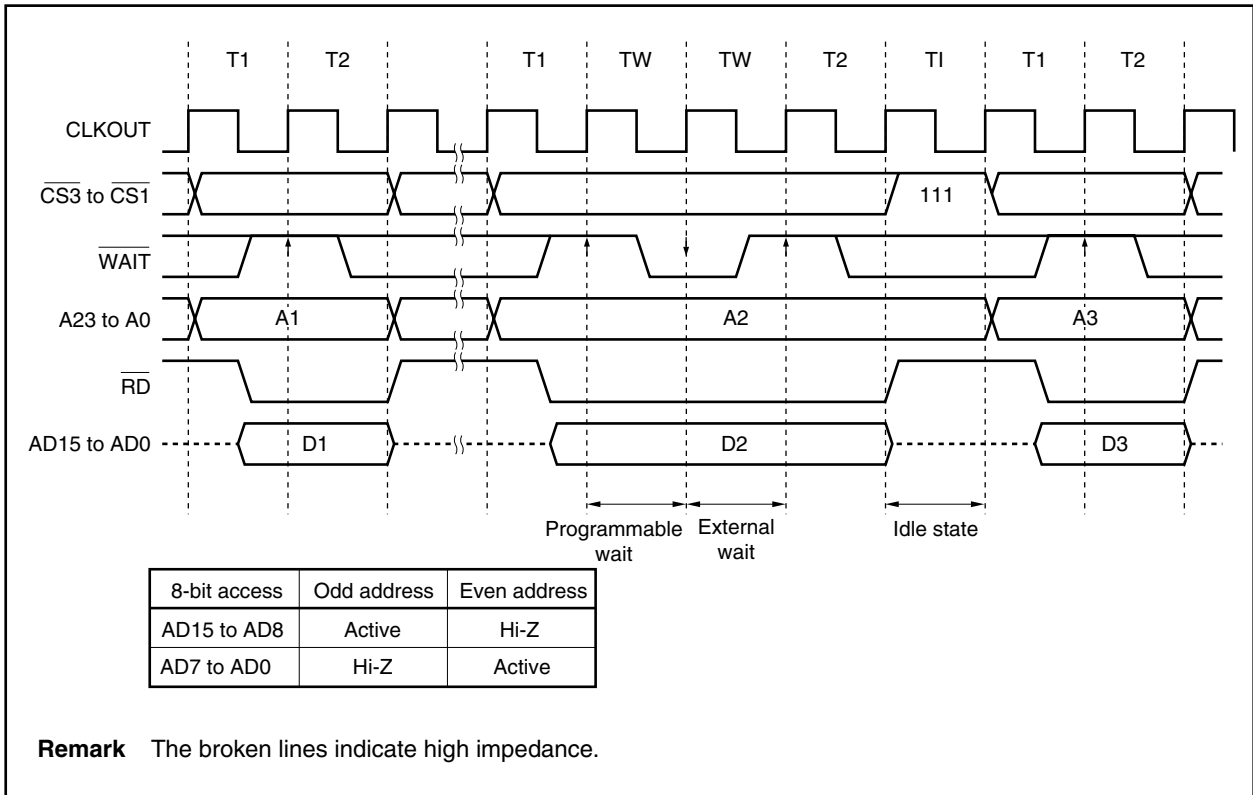

Figure 5-12. Separate Bus Read Timing (Bus Size: 8 Bits)

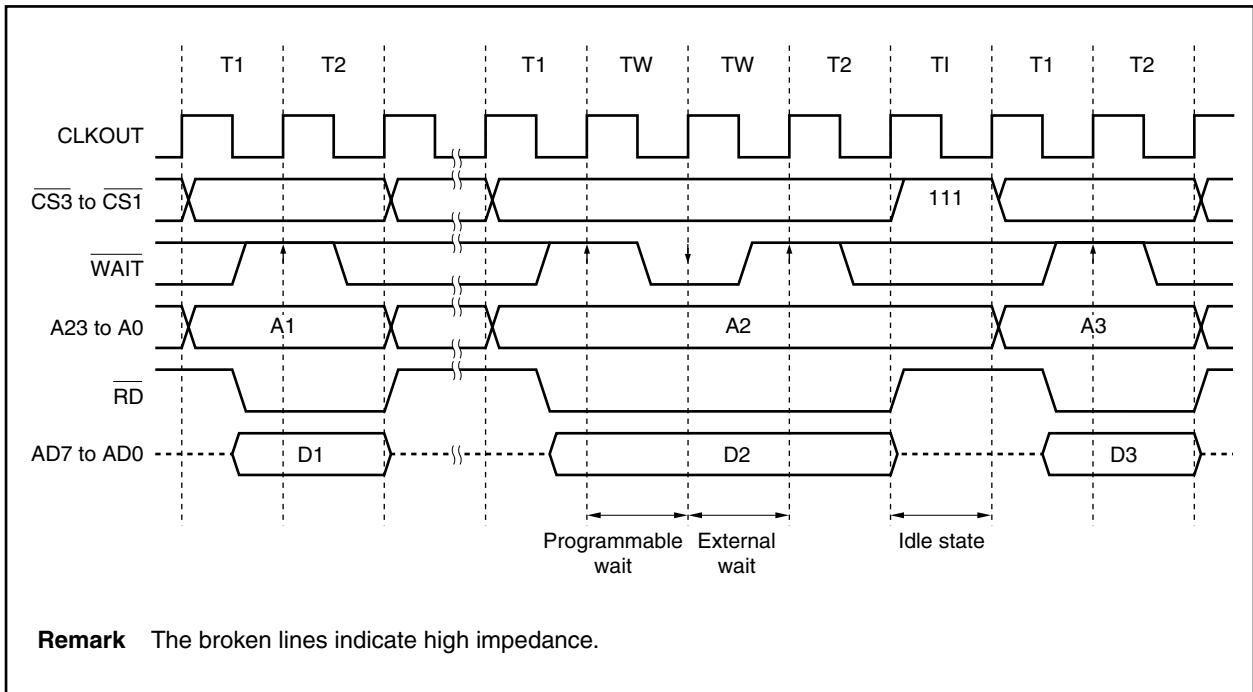
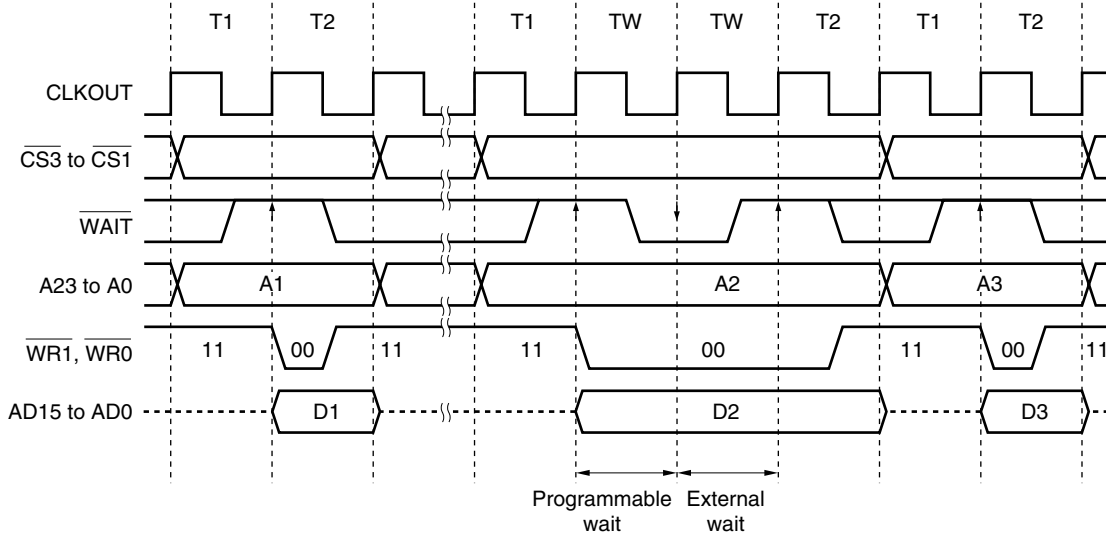
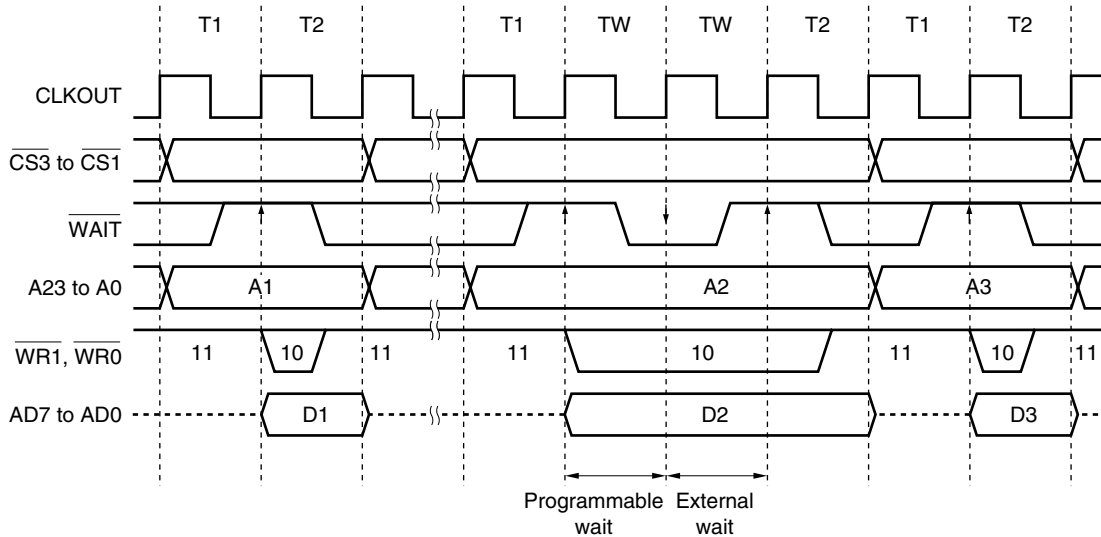

Figure 5-13. Separate Bus Write Timing (Bus Size: 16 Bits, 16-Bit Access)



**Remark** The broken lines indicate high impedance.

Figure 5-14. Separate Bus Write Timing (Bus Size: 8 Bits)



**Remark** The broken lines indicate high impedance.



Figure 5-15. Separate Bus Hold Timing (Bus Size: 8 Bits, Write)

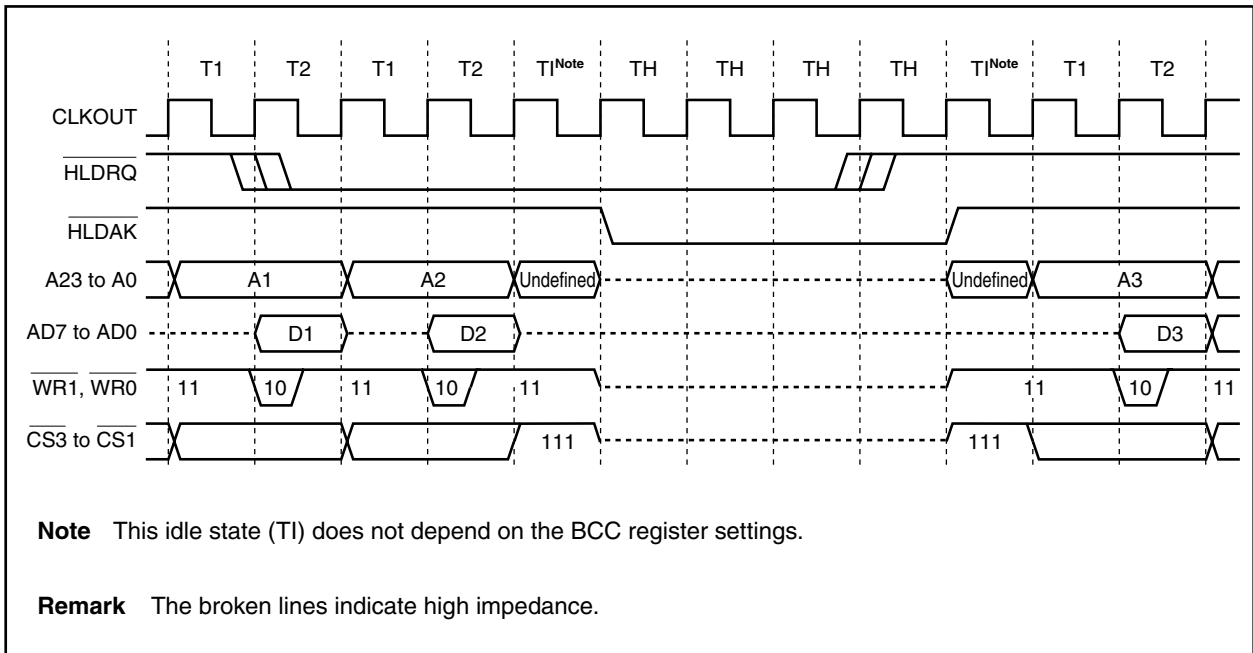
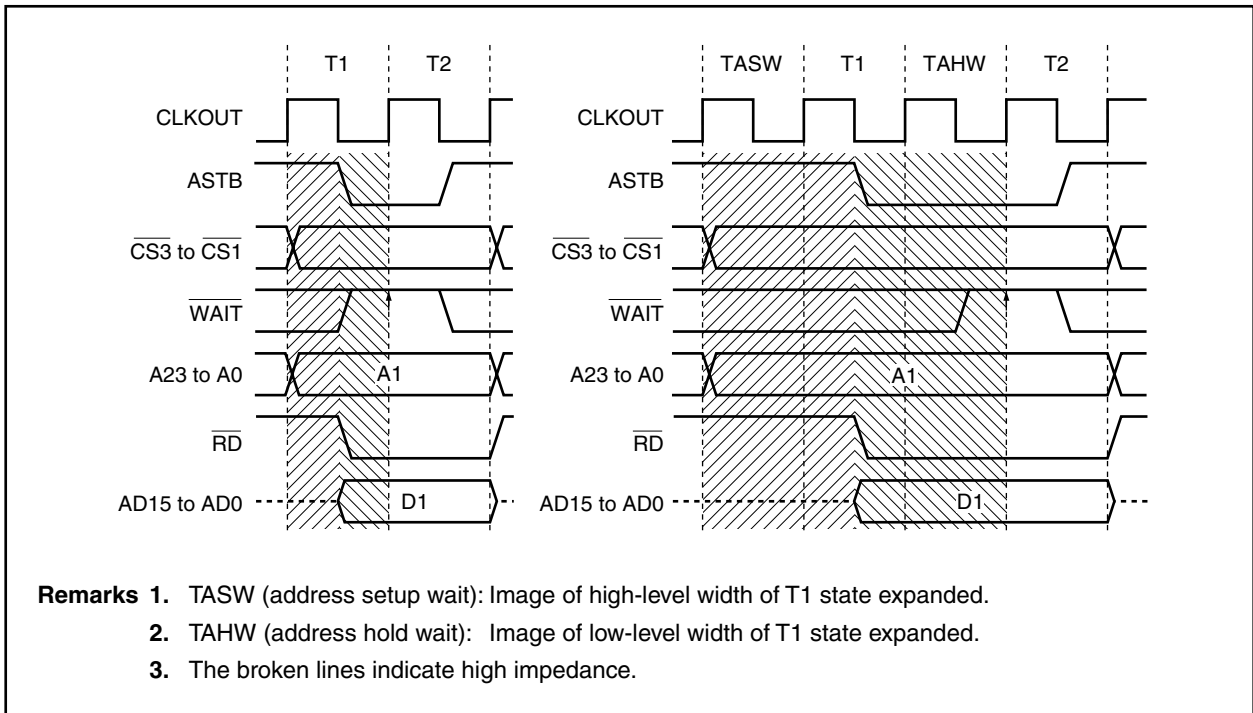

Figure 5-16. Address Wait Timing (Separate Bus Read, Bus Size: 16 Bits, 16-Bit Access)



## CHAPTER 6 CLOCK GENERATION FUNCTION

### 6.1 Overview

An outline of the clock generation function is shown below.

- Main clock oscillator
  - Oscillation ( $f_x$ ) via externally connected 3 to 10 MHz resonator<sup>Note</sup>
- Subclock oscillator
  - Oscillation ( $f_{XT}$ ) via externally connected 32.768 kHz resonator
- On-chip oscillator
  - $f_R = 100$  to 400 kHz, 220 kHz (Typ.)
  - Used as default clock source for watchdog timer 2
  - Used as source clock for TMM0 to TMM2
  - Used as sampling clock for monitoring abnormal stoppage of main clock oscillator (clock monitor)
  - Whether on-chip oscillator can be stopped or not by software can be selected using option byte function
- <R> ○ Multiply function using PLL (Phase Locked Loop)
  - x8 multiplication (Division by 2/no division after x8 multiplication selectable)
- Division function of PLL input clock ( $f_{PLL}$ )
  - Division by 2/no division selectable by using option byte
- Multiply function, frequency modulation function using SSCG (Spread Spectrum Clock Generator)
  - x8 multiplication/x12 multiplication
  - No modulation/modulation selectable
  - Modulation ratio (TYP.): Selectable from -1%, -2% and -4% (using down spread method)
  - Modulation cycle (TYP.): Selectable from 40 kHz, 50 kHz and 60 kHz
- Internal system clock generation
  - Selectable from clock-through or PLL/SSCG output clock used as internal system clock
  - Prescaler for internal system clock: 7 stages ( $f_{XX}$ ,  $f_{XX}/2$ ,  $f_{XX}/4$ ,  $f_{XX}/8$ ,  $f_{XX}/16$ ,  $f_{XX}/32$ ,  $f_{XT}$ )
- Peripheral clock ( $f_{XP}$ ) generation
  - When SSCG is used to generate internal system clock: PLL output clock supplied to on-chip peripheral functions
- Clock output function (CLKOUT pin)

**Note** The selectable frequency range of the externally connected resonator differs depending on the clock mode.

**Remark**  $f_x$ : Main oscillation clock frequency  
 $f_{XX}$ : Main clock frequency  
 $f_{XT}$ : Subclock frequency  
 $f_R$ : On-chip oscillation clock frequency  
 $f_{PLL}$ : PLL input clock frequency  
 $f_{XP}$ : Peripheral clock frequency

## 6.2 Clock Mode

The V850E/SJ3-H and V850E/SK3-H have four clock modes. The features of these clock modes are described below.

**Caution** The clock mode is set using the option byte, and therefore cannot be switched during operation. Consequently, it is important to determine which clock mode is to be used, before starting operation.

- Clock mode 1: In this mode, PLL output (x8 multiplication/divided by 2 after x8 multiplication) can be selected as the main clock (f<sub>xx</sub>), which can operate at up to 32 MHz.  
In this mode, the main clock is used as the source of the peripheral clock.
- Clock mode 2: In this mode, SSCG output (x12 multiplication) can be selected as the main clock (f<sub>xx</sub>), which can operate at up to 48 MHz.  
In this mode, either the main clock or the PLL output divided by 2 (divided by 2 after x8 multiplication: 16 MHz max.) can be selected as the peripheral clock. An undivided PLL output (x8 multiplication: 32 MHz max.) can also be selected for the clock supplied to the IEBus controller and CAN controller.
- Clock mode 3: In this mode, SSCG output (x8/x12 multiplication) can be selected as the main clock (f<sub>xx</sub>), which can operate at up to 48 MHz.  
In this mode, either the main clock or the PLL output (x8 multiplication: 32 MHz max.) can be selected as the peripheral clock.
- Clock mode 4: In this mode, SSCG output (x8 multiplication) can be selected as the main clock (f<sub>xx</sub>), which can operate at up to 48 MHz.  
In this mode, either the main clock or the PLL output divided by 2 (divided by 2 after x8 multiplication: 24 MHz max.) can be selected as the peripheral clock.  
The IEBus controller cannot be used in this mode.

The frequency range of the operating clocks in each clock mode and the corresponding source clocks are shown in the table below.

Table 6-1. Frequency Range of Operating Clocks in Each Clock Mode and Corresponding Source Coeks (1/2)

<R>	Clock Mode	Option Byte 0000007BH <sup>Note</sup>	Range of Main Oscillation Clock Frequency (fx)	Settable Operating Mode and Main Clock Frequency (f <sub>xx</sub> )	Source Clock of Peripheral Clock (f <sub>XP</sub> ), IEBus Clock (f <sub>IE</sub> ), CAN Clock (f <sub>CAN</sub> )
		Setting value of PLL10 bit			
<R>	Clock mode 1	0	3 to 10 MHz	Clock-through mode: 3 to 10 MHz	Main clock: 3 to 10 MHz (f <sub>XP</sub> = f <sub>IE</sub> = f <sub>CAN</sub> = f <sub>XX</sub> )
			3 to 5 MHz	Clock-through mode: 3 to 5 MHz	Main clock: 3 to 5 MHz (f <sub>XP</sub> = f <sub>IE</sub> = f <sub>CAN</sub> = f <sub>XX</sub> )
				PLL mode (divided by 2 after x8 multiplication) 12 to 20 MHz	Main clock: 12 to 20 MHz (f <sub>XP</sub> = f <sub>IE</sub> = f <sub>CAN</sub> = f <sub>XX</sub> )
			3 to 4 MHz	Clock-through mode: 3 to 4 MHz	Main clock: 3 to 4 MHz (f <sub>XP</sub> = f <sub>IE</sub> = f <sub>CAN</sub> = f <sub>XX</sub> )
		PLL mode (x8 multiplication) 24 to 32 MHz		Main clock: 24 to 32 MHz (f <sub>XP</sub> = f <sub>IE</sub> = f <sub>CAN</sub> = f <sub>XX</sub> )	
		1	6 to 10 MHz	Clock-through mode: 6 to 10 MHz	Main clock: 6 to 10 MHz (f <sub>XP</sub> = f <sub>IE</sub> = f <sub>CAN</sub> = f <sub>XX</sub> )
				PLL mode (divided by 2 after x8 multiplication) 12 to 20 MHz	
			6 to 8 MHz	Clock-through mode: 6 to 8 MHz	Main clock: 6 to 8 MHz (f <sub>XP</sub> = f <sub>IE</sub> = f <sub>CAN</sub> = f <sub>XX</sub> )
PLL mode (x8 multiplication) 24 to 32 MHz	Main clock: 24 to 32 MHz (f <sub>XP</sub> = f <sub>IE</sub> = f <sub>CAN</sub> = f <sub>XX</sub> )				
<R>	Clock mode 2	0	3.66 to 4 MHz	Clock-through mode: 3.66 to 4 MHz	• f <sub>XP</sub> PLL clock (divided by 2 after x8 multiplication) 14.64 to 16 MHz
				SSCG mode (x12 multiplication) 43.92 to 48 MHz	
		1	7.32 to 8 MHz	Clock-through mode: 7.32 to 8 MHz	• f <sub>IE</sub> , f <sub>CAN</sub> PLL clock (x8 multiplication) 29.28 to 32 MHz
				SSCG mode (x12 multiplication) 43.92 to 48 MHz	

<R> **Note** For details, see CHAPTER 33 OPTION BYTE FUNCTION.

- Cautions**
1. In clock mode 1, the main clock (f<sub>xx</sub>) is supplied as the source of the peripheral clock (f<sub>XP</sub>, f<sub>IE</sub>, f<sub>CAN</sub>). In this mode, the SSCG output clock cannot be used as the main clock.
  2. In clock mode 2, the SSCG output clock is used as the main clock and the PLL output is used as the peripheral clock. In these modes, the PLL output clock cannot be used as the main clock. Also, when clock-through mode is selected for the main clock, the source of the peripheral clock is the PLL output clock.

Table 6-1. Frequency Range of Operating Clocks in Each Clock Mode and Corresponding Source Clocks (2/2)

<R>	Clock Mode	Option Byte 0000007BH <sup>Note</sup>	Range of Main Oscillation Clock Frequency (fx)	Settable Operating Mode and Main Clock Frequency (f <sub>xx</sub> )	Source Clock of Peripheral Clock (f <sub>XP</sub> ), IEBus Clock (f <sub>IE</sub> ), CAN Clock (f <sub>CAN</sub> )
		Setting value of PLL10 bit			
<R>	Clock mode 3	0	3.66 to 4 MHz	Clock-through mode: 3.66 to 4 MHz	PLL clock (x8 multiplication) 29.28 to 32 MHz (f <sub>XP</sub> = f <sub>IE</sub> = f <sub>CAN</sub> )
				SSCG mode (x8 multiplication) 29.28 to 32 MHz	
				SSCG mode (x12 multiplication) 43.92 to 48 MHz	
		1	7.32 to 8 MHz	Clock-through mode: 7.32 to 8 MHz	
				SSCG mode (x8 multiplication) 29.28 to 32 MHz	
				SSCG mode (x12 multiplication) 43.92 to 48 MHz	
<R>	Clock mode 4	0	5.22 to 6 MHz	Clock-through mode: 5.22 to 6 MHz	PLL clock (divided by 2 after x8 multiplication) 20.88 to 24 MHz (f <sub>XP</sub> = f <sub>IE</sub> = f <sub>CAN</sub> )
				SSCG mode (x8 multiplication) 41.76 to 48 MHz	
		1	Setting prohibited		

<R> **Note** For details, see CHAPTER 33 OPTION BYTE FUNCTION.

**Cautions 1.** In clock modes 3 and 4, the SSCG output clock is used as the main clock and the PLL output is used as the peripheral clock. In these modes, the PLL output clock cannot be used as the main clock. Also, when clock-through mode is selected for the main clock, the source of the peripheral clock is the PLL output clock.

**2.** The IEBus controller cannot be used in clock mode 4.

6.2.1 Clock mode 1

<R>

Figure 6-1. Clock Generation Circuit for Clock Mode 1

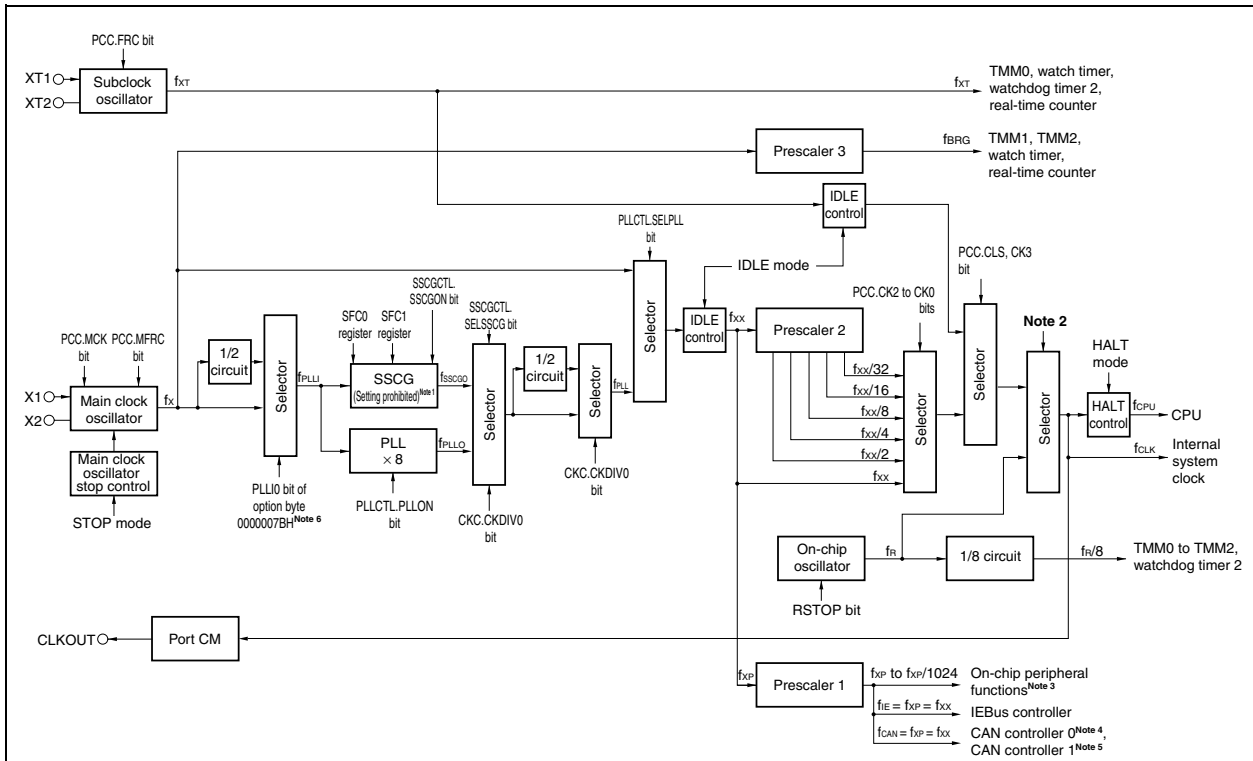

- Notes**
- SSCG cannot be used in clock mode 1.
  - The internal oscillation clock ( $f_r$ ) is selected when watchdog timer 2 overflows during the oscillation stabilization time.
  - Internal peripheral functions: TMP0 to TMP8, TMQ0, TMM0 to TMM2, CSIB0 to CSIB5, CSIE0<sup>Note 7</sup>, CSIE1<sup>Note 7</sup>, UARTA0 to UARTA5, UARTB0, UARTB1, I<sup>2</sup>C00 to I<sup>2</sup>C03, I<sup>2</sup>C04<sup>Note 7</sup>, I<sup>2</sup>C05<sup>Note 7</sup>, ADC, WDT2
  - CAN controller versions only
  - CAN controller (2-channel) versions only
  - For details, see **CHAPTER 33 OPTION BYTE FUNCTION**.
  - Not available in the  $\mu$ PD70F3931 (V850E/SJ3-H), 70F3932 (V850E/SJ3-H), and 70F3933 (V850E/SJ3-H)

**Remark**

$f_x$ :	Main oscillation clock frequency
$f_{XT}$ :	Subclock frequency
$f_r$ :	On-chip oscillation clock frequency
$f_{PLL}$ :	PLL input clock frequency
$f_{PLLO}$ :	PLL output clock frequency
$f_{SSCGO}$ :	SSCG output clock frequency
$f_{PLL}$ :	Multiplication clock frequency
$f_{XX}$ :	Main clock frequency
$f_{CLK}$ :	Internal system clock frequency
$f_{CPU}$ :	CPU clock frequency
$f_{XP}$ :	Peripheral clock frequency (Prescaler 1 input clock frequency)
$f_{IE}$ :	IEBus clock frequency
$f_{CAN}$ :	CAN clock frequency
$f_{BRG}$ :	Prescaler 3 output clock frequency

**(1) Main clock oscillator**

The main resonator oscillates the following frequencies ( $f_x$ ).

(a) PLLI0 bit of the option byte 0000007BH = 0 (no division) (See **CHAPTER 33 OPTION BYTE FUNCTION.**)

- In clock-through mode  
 $f_x = 3$  to 10 MHz
- In PLL mode  
 $f_x = 3$  to 5 MHz (PLL: divided by 2 after x8 multiplication)  
 $f_x = 3$  to 4 MHz (PLL: x8 multiplication)

<R>

(b) PLLI0 bit = 1 (divided by 2)

- In clock-through mode  
 $f_x = 6$  to 10 MHz
- In PLL mode  
 $f_x = 6$  to 10 MHz (PLL: divided by 2 after x8 multiplication)  
 $f_x = 6$  to 8 MHz (PLL: x8 multiplication)

The main clock oscillator starts operating after reset release.

**(2) Subclock oscillator**

The sub-resonator oscillates a frequency of 32.768 kHz ( $f_{XT}$ ).

**(3) Main clock oscillator stop control**

This circuit generates a control signal that stops oscillation of the main clock oscillator.

Oscillation of the main clock oscillator is stopped in the STOP mode or when the PCC.MCK bit = 1 (valid only when the PCC.CLS bit = 1).

**(4) Internal oscillator**

Oscillates a frequency ( $f_R$ ) of 220 kHz (TYP.).

Oscillation can be stopped by setting the RCM.RSTOP bit. However, oscillation cannot be stopped if stopping the on-chip oscillator has been disabled by setting the RMOPIN bit of the option byte 0000007AH (see **CHAPTER 33 OPTION BYTE FUNCTION** for details) to 1.

**(5) PLL**

<R>

The PLL multiplies the PLL input clock ( $f_{PLLI}$ ) by 8 (32 MHz max.). The PLL output clock ( $f_{PLLO}$ ) can be selected as the main clock ( $f_{XX}$ ). Clock-through mode, in which  $f_x$  is output as is, or PLL mode, in which the multiplied clock is output, can be selected by setting the PLLCTL.SELPLL bit.

The PLL output clock ( $f_{PLLO}$ ) can be divided by 2 by setting the CKC.CKDIV0 bit. Operation of the PLL can also be enabled/stopped by setting the PLLCTL.PLLON bit.

The PLL either starts operating or enters the locked state after reset release (PLLCTL.PLLON bit = 1, LOCKR.LOCK bit = 0).

**(6) SSCG**

The SSCG cannot be used in clock mode 1.

**(7) Prescaler 1**

Prescaler 1 generates the clock to be supplied to the on-chip peripheral functions ( $f_{XP}$  to  $f_{XP}/1024$ ), using the peripheral clock ( $f_{XP}$ ) (= main clock ( $f_{XX}$ )) as the source clock.

The following blocks are supplied by this clock.

<R> TMP0 to TMP8, TMQ0, TMM0 to TMM2, CSIB0 to CSIB5, CSIE0<sup>Note 1</sup>, CSIE1<sup>Note 1</sup>, UARTA0 to UARTA5,  
 <R> UARTB0, UARTB1, I<sup>2</sup>C00 to I<sup>2</sup>C03, I<sup>2</sup>C04<sup>Note 1</sup>, I<sup>2</sup>C05<sup>Note 1</sup>, ADC, WDT2, CAN0<sup>Note 2</sup>, CAN1<sup>Note 3</sup>, IEBus

<R> **Notes** 1. Not available in the  $\mu$ PD70F3931 (V850E/SJ3-H), 70F3932 (V850E/SJ3-H), and 70F3933 (V850E/SJ3-H)

2. CAN controller versions only

3. CAN controller (2-channel) versions only

**(8) Prescaler 2**

This circuit divides the main clock ( $f_{XX}$ ).

The clock generated by prescaler 2 ( $f_{XX}$  to  $f_{XX}/32$ ) is supplied to the selector that generates the CPU clock ( $f_{CPU}$ ) and internal system clock ( $f_{CLK}$ ).

$f_{CLK}$  is the clock supplied to the DMAC, INTC, ROM correction, ROM, RAM, and expanded internal RAM block, and can be output from the CLKOUT pin.

**(9) Prescaler 3**

This circuit divides the clock generated by the main clock oscillator ( $f_X$ ) to a specific frequency and supplies that clock to the watch timer, TMM1, TMM2, and real-time counter block.

For details, see **CHAPTER 10 WATCH FUNCTIONS**.



6.2.2 Clock mode 2

<R>

Figure 6-2. Clock Generation Circuit for Clock Mode 2 (1/2)

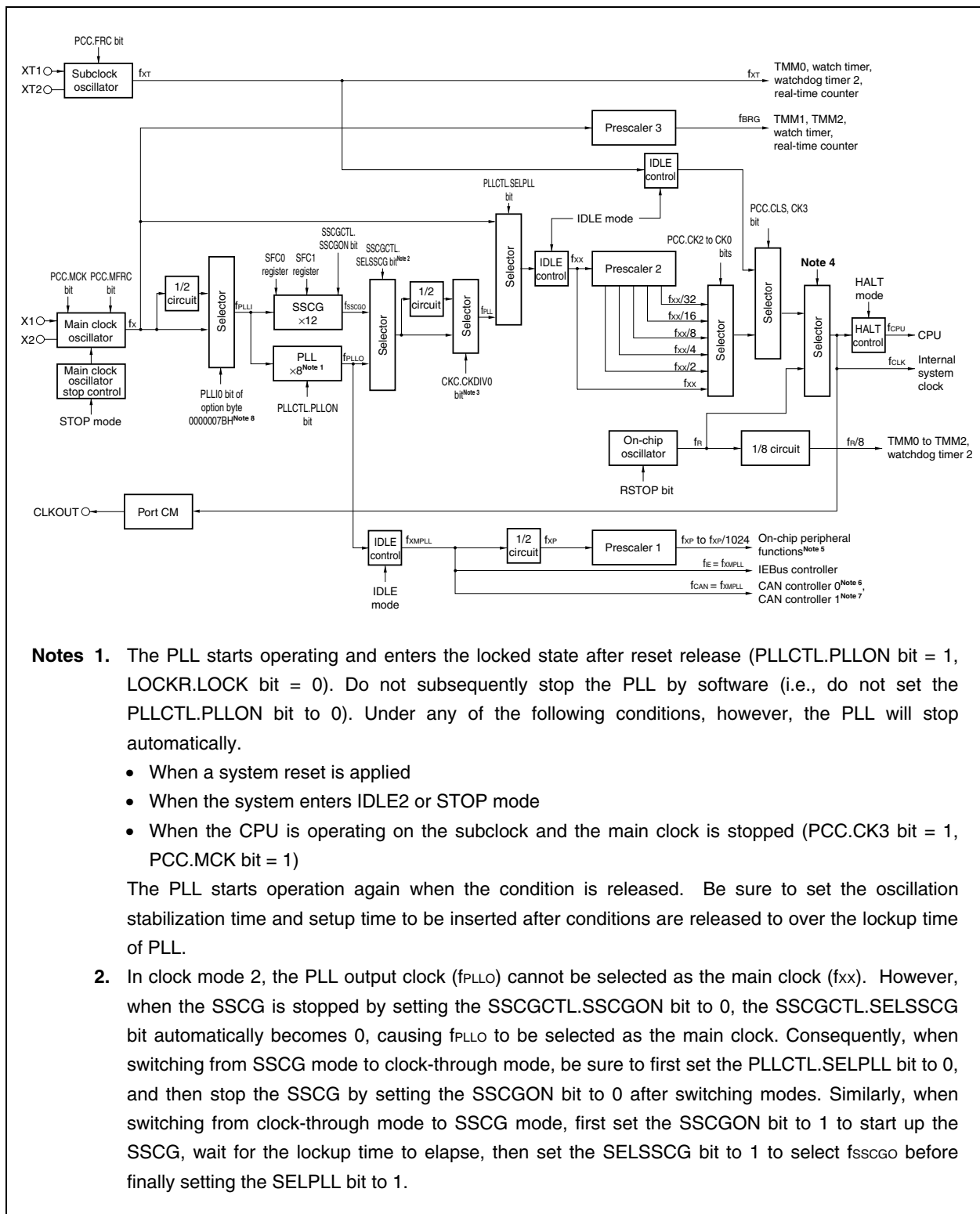

&lt;R&gt;

**Figure 6-2. Clock Generation Circuit for Clock Mode 2 (2/2)**

- Notes**
3. In clock mode 2, be sure to set the CKC.CKDIV0 bit to 1 (no division).
  4. The internal oscillation clock ( $f_R$ ) is selected when watchdog timer 2 overflows during the oscillation stabilization time.
  5. Internal peripheral functions: TMP0 to TMP8, TMQ0, TMM0 to TMM2, CSIB0 to CSIB5, CSIE0<sup>Note 9</sup>, CSIE1<sup>Note 9</sup>, UARTA0 to UARTA5, UARTB0, UARTB1, I<sup>2</sup>C00 to I<sup>2</sup>C03, I<sup>2</sup>C04<sup>Note 9</sup>, I<sup>2</sup>C05<sup>Note 9</sup>, ADC, WDT2
  6. CAN controller versions only
  7. CAN controller (2-channel) versions only.
  8. For details, see **CHAPTER 33 OPTION BYTE FUNCTION**.
  9. Not available in the  $\mu$ PD70F3931 (V850E/SJ3-H), 70F3932 (V850E/SJ3-H), and 70F3933 (V850E/SJ3-H)

**Remark**

$f_x$ :	Main oscillation clock frequency
$f_{XT}$ :	Subclock frequency
$f_R$ :	On-chip oscillation clock frequency
$f_{PLL}$ :	PLL input clock frequency
$f_{PLO}$ :	PLL output clock frequency
$f_{SSCGO}$ :	SSCG output clock frequency
$f_{PLL}$ :	Multiplication clock frequency
$f_{XX}$ :	Main clock frequency
$f_{CLK}$ :	Internal system clock frequency
$f_{CPU}$ :	CPU clock frequency
$f_{XPLL}$ :	Peripheral clock for PLL output clock frequency
$f_{XP}$ :	Peripheral clock frequency (Prescaler 1 input clock frequency)
$f_{IE}$ :	IEBus clock frequency
$f_{CAN}$ :	CAN clock frequency
$f_{BRG}$ :	Prescaler 3 output clock frequency

**(1) Main clock oscillator**

Oscillates a next frequency ( $f_x$ ).

- (a) PLLI0 bit of the option byte 0000007BH (see **CHAPTER 33 OPTION BYTE FUNCTION** for details) = 0 (no division)

- $f_x = 3.66$  to 4 MHz

&lt;R&gt;

- (b) PLLI0 bit = 1 (divided by 2)

- $f_x = 7.32$  to 8 MHz

The main clock oscillator starts operating after reset release.

**(2) Subclock oscillator**

The subclock oscillator oscillates a frequency of 32.768 kHz ( $f_{XT}$ ).

**(3) Main clock oscillator stop control**

This circuit generates a control signal that stops oscillation of the main clock oscillator.

Oscillation of the main clock oscillator is stopped in the STOP mode or when the PCC.MCK bit = 1 (valid only when the PCC.CLS bit = 1).

**(4) Internal oscillator**

Oscillates a frequency ( $f_R$ ) of 220 kHz (TYP.).

Oscillation can be stopped by setting the RCM.RSTOP bit. However, oscillation cannot be stopped if stopping the on-chip oscillator has been disabled by setting the RMOPIN bit of the option byte 0000007AH (see **CHAPTER 33 OPTION BYTE FUNCTION** for details) to 1.

**(5) PLL**

<R> The PLL divides the PLL input clock ( $f_{PLL}$ ) by 2 after multiplies by 8 (16 MHz max.) to generate a peripheral clock ( $f_{XP}$ ).

**(6) SSCG**

<R> The SSCG multiplies the PLL input clock ( $f_{PLL}$ ) by 12 (48 MHz max.). The SSCG output clock ( $f_{SSCGO}$ ) can be selected as the main clock ( $f_{XX}$ ). Clock-through mode, in which  $f_X$  is output as is, or SSCG mode, in which  $f_{SSCGO}$  is output, can be selected by setting the PLLCTL.SELPLL bit.

In SSCG mode, the frequency modulation function can be used to effectively reduce the peak EMI noise value. Frequency modulation/no frequency modulation, the frequency modulation ratio (down spread method), and the frequency cycle can be set only once after reset.

Whether to operate or stop the SSCG can also be controlled using the SSCGCTL.SSCGON bit. Note that the setting of this bit is only valid when the PLLCTL.PLLON bit is set to 1.

The SSCG stops operating after reset.

**(7) Prescaler 1**

Prescaler 1 generates the clock to be supplied to the on-chip peripheral functions ( $f_{XP}$  to  $f_{XP}/1024$ ), using the peripheral clock ( $f_{XP}$ ) (= PLL output clock for peripheral clock ( $f_{XMPLL}$ ) divided by 2) as the source clock.

The following blocks are supplied by this clock.

<R> TMP0 to TMP8, TMQ0, TMM0 to TMM2, CSIB0 to CSIB5, CSIE0<sup>Note 1</sup>, CSIE1<sup>Note 1</sup>, UARTA0 to UARTA5,

<R> UARTB0, UARTB1, I<sup>2</sup>C00 to I<sup>2</sup>C03, I<sup>2</sup>C04<sup>Note 1</sup>, I<sup>2</sup>C05<sup>Note 1</sup>, ADC, WDT2

Note that the PLL output clock for the peripheral clock ( $f_{XMPLL}$ ) is supplied directly to the CAN0<sup>Note 2</sup>, CAN1<sup>Note 3</sup>, and IEBus blocks.

<R> **Notes** 1. Not available in the  $\mu$ PD70F3931 (V850E/SJ3-H), 70F3932 (V850E/SJ3-H), and 70F3933 (V850E/SJ3-H)

2. CAN controller versions only

3. CAN controller (2-channel) versions only

**(8) Prescaler 2**

This circuit divides the main clock ( $f_{XX}$ ).

The clock generated by prescaler 2 ( $f_{XX}$  to  $f_{XX}/32$ ) is supplied to the selector that generates the CPU clock ( $f_{CPU}$ ) and internal system clock ( $f_{CLK}$ ).

$f_{CLK}$  is the clock supplied to the DMAC, INTC, ROM correction, ROM, RAM, and expanded internal RAM blocks, and can be output from the CLKOUT pin.

**(9) Prescaler 3**

This circuit divides the clock generated by the main clock oscillator ( $f_X$ ) to a specific frequency and supplies that clock to the watch timer, TMM1, TMM2, and real-time counter (RTC) blocks.

For details, see **CHAPTER 10 WATCH FUNCTIONS**.

6.2.3 Clock mode 3

<R>

Figure 6-3. Clock Generation Circuit for Clock Mode 3 (1/2)

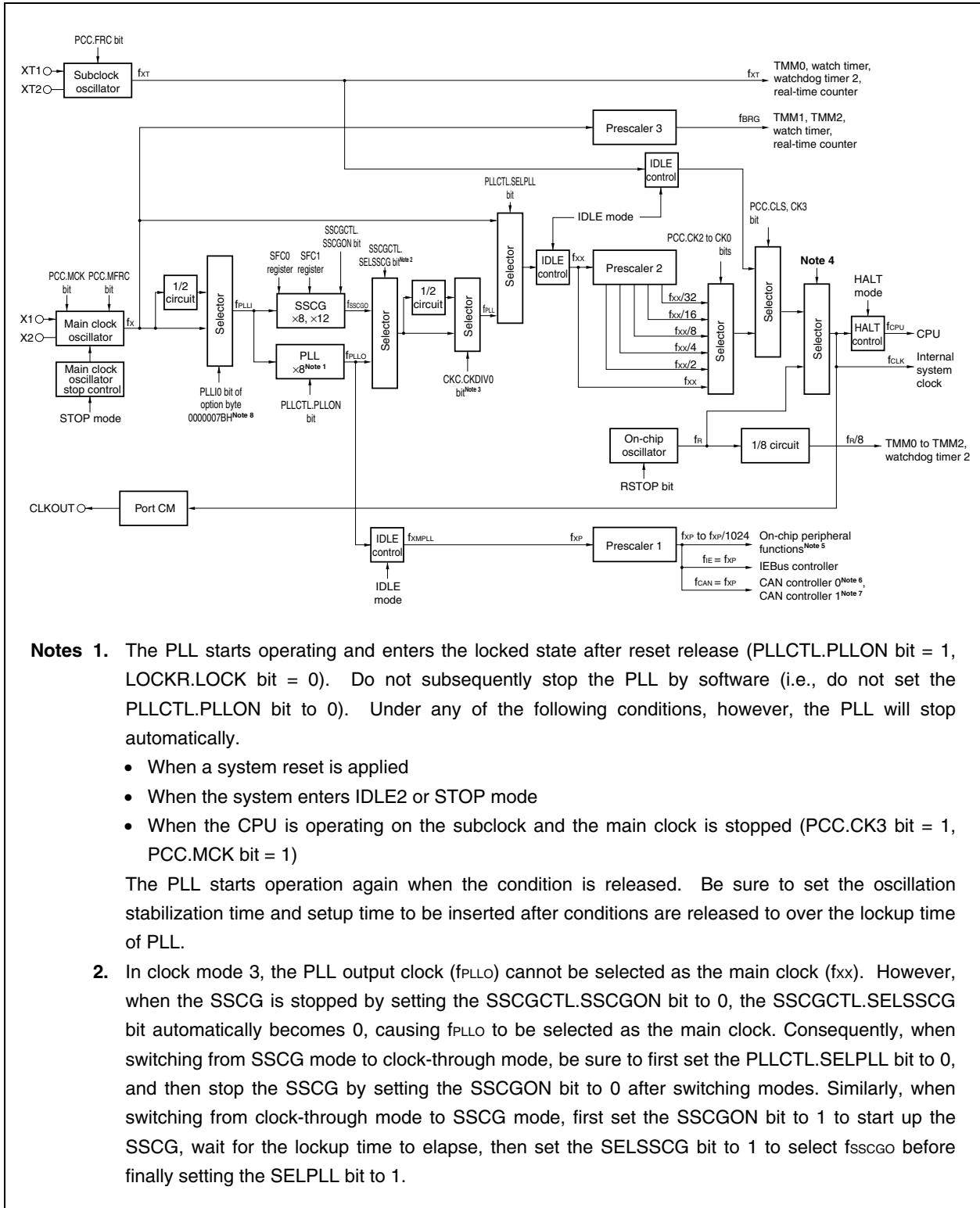

&lt;R&gt;

Figure 6-3. Clock Generation Circuit for Clock Mode 3 (2/2)

- Notes**
3. In clock mode 3, be sure to set the CKC.CKDIV0 bit to 1 (no division).
  4. The internal oscillation clock ( $f_R$ ) is selected when watchdog timer 2 overflows during the oscillation stabilization time.
  5. Internal peripheral functions: TMP0 to TMP8, TMQ0, TMM0 to TMM2, CSIB0 to CSIB5, CSIE0<sup>Note 9</sup>, CSIE1<sup>Note 9</sup>, UARTA0 to UARTA5, UARTB0, UARTB1, I<sup>2</sup>C00 to I<sup>2</sup>C03, I<sup>2</sup>C04<sup>Note 9</sup>, I<sup>2</sup>C05<sup>Note 9</sup>, ADC, WDT2
  6. CAN controller versions only
  7. CAN controller (2-channel) versions only
  8. For details, see **CHAPTER 33 OPTION BYTE FUNCTION**.
  9. Not available in the  $\mu$ PD70F3931 (V850E/SJ3-H), 70F3932 (V850E/SJ3-H), and 70F3933 (V850E/SJ3-H)

**Remark**

fx:	Main oscillation clock frequency
fxT:	Subclock frequency
fR:	On-chip oscillation clock frequency
fPLLI:	PLL input clock frequency
fPULO:	PLL output clock frequency
fSSCGO:	SSCG output clock frequency
fPLL:	Multiplication clock frequency
fxX:	Main clock frequency
fCLK:	Internal system clock frequency
fCPU:	CPU clock frequency
fxMPLL:	Peripheral clock for PLL output clock frequency
fxP:	Peripheral clock frequency (Prescaler 1 input clock frequency)
fIE:	IEBus clock frequency
fCAN:	CAN clock frequency
fBRG:	Prescaler 3 output clock frequency

**(1) Main clock oscillator**

Oscillates a next frequency ( $f_x$ ).

(a) PLLI0 bit of the option byte 0000007BH = 0 (no division) (See **CHAPTER 33 OPTION BYTE FUNCTION**.)

- $f_x = 3.66$  to 4 MHz

&lt;R&gt;

(b) PLLI0 bit = 1 (divided by 2)

- $f_x = 7.32$  to 8 MHz

The main clock oscillator starts operating after reset release.

**(2) Subclock oscillator**

The subclock oscillator oscillates a frequency of 32.768 kHz ( $f_{xT}$ ).

**(3) Main clock oscillator stop control**

This circuit generates a control signal that stops oscillation of the main clock oscillator.

Oscillation of the main clock oscillator is stopped in the STOP mode or when the PCC.MCK bit = 1 (valid only when the PCC.CLS bit = 1).

**(4) Internal oscillator**

Oscillates a frequency ( $f_R$ ) of 220 kHz (TYP.).

Oscillation can be stopped by setting the RCM.RSTOP bit. However, oscillation cannot be stopped if stopping the on-chip oscillator has been disabled by setting the RMOPIN bit of the option byte 0000007AH (see **CHAPTER 33 OPTION BYTE FUNCTION** for details) to 1.

**(5) PLL**

<R> The PLL multiplies the PLL input clock ( $f_{PLL}$ ) by 8 (32 MHz max.) to generate a peripheral clock ( $f_{PLL}$ ).

**(6) SSCG**

<R> The SSCG multiplies the PLL input clock ( $f_{PLL}$ ) by 8 (32 MHz max.). The SSCG output clock ( $f_{SSCG}$ ) can be selected as the main clock ( $f_{XX}$ ). Clock-through mode, in which  $f_X$  is output as is, or SSCG mode, in which  $f_{SSCG}$  is output, can be selected by setting the PLLCTL.SELPLL bit.

In SSCG mode, the frequency modulation function can be used to effectively reduce the peak EMI noise value. Frequency modulation/no frequency modulation, the frequency modulation ratio (down spread method), and the frequency cycle can be set only once after reset.

Whether to operate or stop the SSCG can also be controlled using the SSCGCTL.SSCGON bit. Note that the setting of this bit is only valid when the PLLCTL.PLLON bit is set to 1.

The SSCG stops operating after reset.

**(7) Prescaler 1**

Prescaler 1 generates the clock to be supplied to the on-chip peripheral functions ( $f_{XP}$  to  $f_{XP}/1024$ ), using the peripheral clock ( $f_{XP}$ ) (= PLL output clock for peripheral clock ( $f_{XPLL}$ )) as the source clock.

The following blocks are supplied by this clock.

<R> TMP0 to TMP8, TMQ0, TMM0 to TMM2, CSIB0 to CSIB5, CSIE0<sup>Note 1</sup>, CSIE1<sup>Note 1</sup>, UARTA0 to UARTA5,  
<R> UARTB0, UARTB1, I<sup>2</sup>C00 to I<sup>2</sup>C03, I<sup>2</sup>C04<sup>Note 1</sup>, I<sup>2</sup>C05<sup>Note 1</sup>, ADC, WDT2, CAN0<sup>Note 2</sup>, CAN1<sup>Note 3</sup>, IEBus

<R> **Notes** 1. Not available in the  $\mu$ PD70F3931 (V850E/SJ3-H), 70F3932 (V850E/SJ3-H), and 70F3933 (V850E/SJ3-H)

2. CAN controller versions only

3. CAN controller (2-channels) versions only

**(8) Prescaler 2**

This circuit divides the main clock ( $f_{XX}$ ).

The clock generated by prescaler 2 ( $f_{XX}$  to  $f_{XX}/32$ ) is supplied to the selector that generates the CPU clock ( $f_{CPU}$ ) and internal system clock ( $f_{CLK}$ ).

$f_{CLK}$  is the clock supplied to the DMAC, INTC, ROM correction, ROM, RAM, and expanded internal RAM blocks, and can be output from the CLKOUT pin.

**(9) Prescaler 3**

This circuit divides the clock generated by the main clock oscillator ( $f_X$ ) to a specific frequency and supplies that clock to the watch timer, TMM1, TMM2, and real-time counter (RTC) blocks.

For details, see **CHAPTER 10 WATCH FUNCTIONS**.

6.2.4 Clock mode 4

<R>

Figure 6-4. Clock Generation Circuit for Clock Mode 4 (1/2)

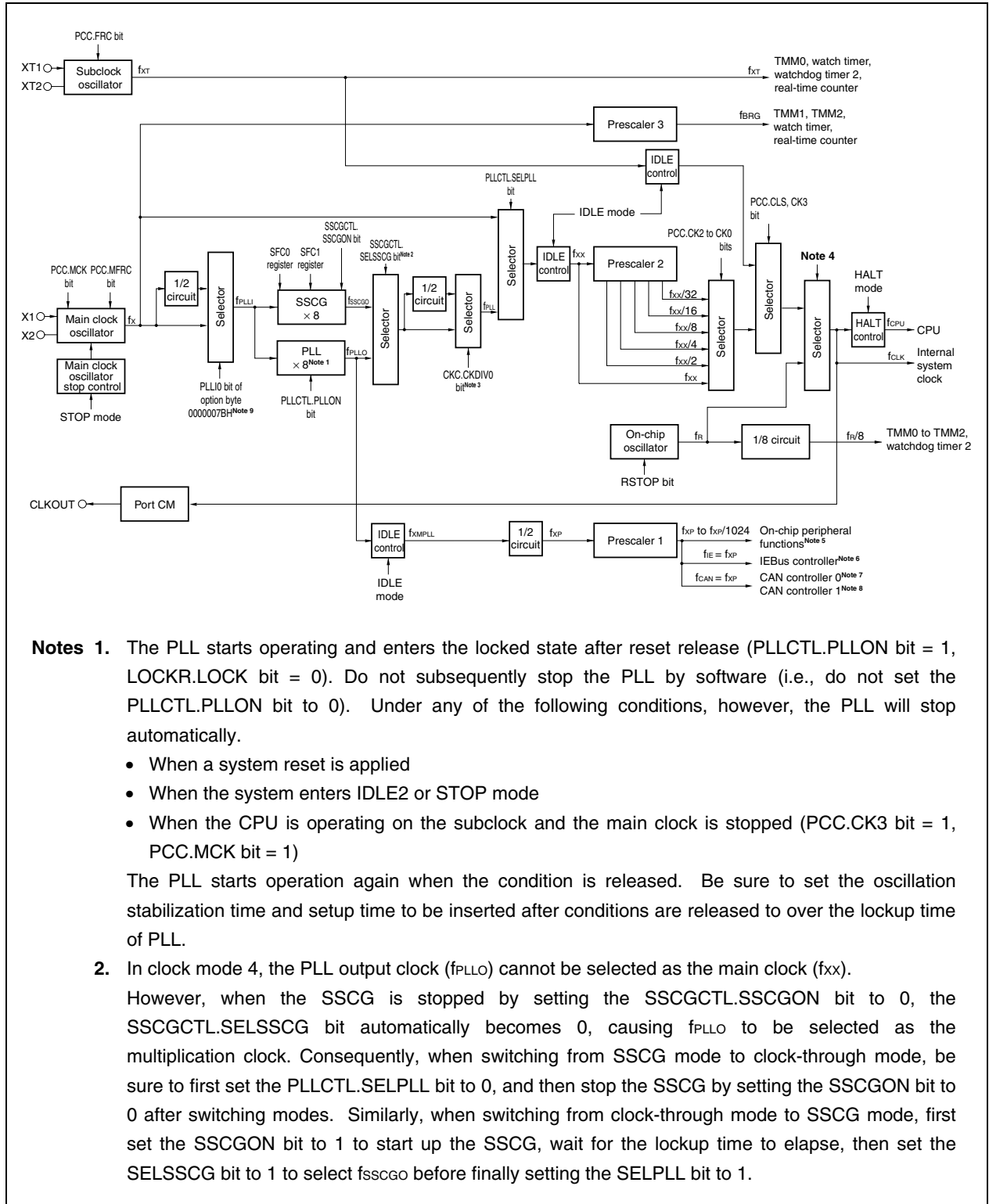

**Notes 1.** The PLL starts operating and enters the locked state after reset release (PLLCTL.PLLON bit = 1, LOCKR.LOCK bit = 0). Do not subsequently stop the PLL by software (i.e., do not set the PLLCTL.PLLON bit to 0). Under any of the following conditions, however, the PLL will stop automatically.

- When a system reset is applied
- When the system enters IDLE2 or STOP mode
- When the CPU is operating on the subclock and the main clock is stopped (PCC.CK3 bit = 1, PCC.MCK bit = 1)

The PLL starts operation again when the condition is released. Be sure to set the oscillation stabilization time and setup time to be inserted after conditions are released to over the lockup time of PLL.

**2.** In clock mode 4, the PLL output clock (f<sub>PLLO</sub>) cannot be selected as the main clock (f<sub>xx</sub>).

However, when the SSCG is stopped by setting the SSGGCTL.SSGON bit to 0, the SSGGCTL.SELSSCG bit automatically becomes 0, causing f<sub>PLLO</sub> to be selected as the multiplication clock. Consequently, when switching from SSCG mode to clock-through mode, be sure to first set the PLLCTL.SELPLL bit to 0, and then stop the SSCG by setting the SSGON bit to 0 after switching modes. Similarly, when switching from clock-through mode to SSCG mode, first set the SSGON bit to 1 to start up the SSCG, wait for the lockup time to elapse, then set the SELSSCG bit to 1 to select f<sub>SSCG</sub> before finally setting the SELPLL bit to 1.

&lt;R&gt;

**Figure 6-4. Clock Generation Circuit for Clock Mode 4 (2/2)**

- Notes**
3. In clock mode 4, be sure to set the CKC.CKDIV0 bit to 1 (no division).
  4. The internal oscillation clock ( $f_R$ ) is selected when watchdog timer 2 overflows during the oscillation stabilization time.
  5. Internal peripheral functions: TMP0 to TMP8, TMQ0, TMM0 to TMM2, CSIB0 to CSIB5, CSIE0<sup>Note 10</sup>, CSIE1<sup>Note 10</sup>, UARTA0 to UARTA5, UARTB0, UARTB1, I<sup>2</sup>C00 to I<sup>2</sup>C03, I<sup>2</sup>C04<sup>Note 10</sup>, I<sup>2</sup>C05<sup>Note 10</sup>, ADC, WDT2
  6. The IEBus controller cannot be used in clock mode 4.
  7. CAN controller versions only
  8. CAN controller (2-channel) versions only
  9. In clock mode 4, be sure to set the PLLI0 bit of the option byte 0000007BH to 0 (no division).
  10. Not available in the  $\mu$ PD70F3931 (V850E/SJ3-H), 70F3932 (V850E/SJ3-H), and 70F3933 (V850E/SJ3-H)

**Remark**

fx:	Main oscillation clock frequency
fXT:	Subclock frequency
fR:	On-chip oscillation clock frequency
fPLL:	PLL input clock frequency
fPLLO:	PLL output clock frequency
fSSCGO:	SSCG output clock frequency
fPLL:	Multiplication clock frequency
fXX:	Main clock frequency
fCLK:	Internal system clock frequency
fCPU:	CPU clock frequency
fXMPLL:	Peripheral clock for PLL output clock frequency
fXP:	Peripheral clock frequency (Prescaler 1 input clock frequency)
fIE:	IEBus clock frequency
fCAN:	CAN clock frequency
fBRG:	Prescaler 3 output clock frequency

**(1) Main clock oscillator**

Oscillates a frequency ( $f_x$ ) of 5.22 to 6 MHz.

The main clock oscillator starts operating after reset release.

**(2) Subclock oscillator**

The subclock oscillator oscillates a frequency of 32.768 kHz ( $f_{XT}$ ).

**(3) Main clock oscillator stop control**

This circuit generates a control signal that stops oscillation of the main clock oscillator.

Oscillation of the main clock oscillator is stopped in the STOP mode or when the PCC.MCK bit = 1 (valid only when the PCC.CLS bit = 1).



**(4) Internal oscillator**

Oscillates a frequency ( $f_R$ ) of 220 kHz (TYP.).

Oscillation can be stopped by setting the RCM.RSTOP bit. However, oscillation cannot be stopped if stopping the on-chip oscillator has been disabled by setting the RMOPIN bit of the option byte 0000007AH (see **CHAPTER 33 OPTION BYTE FUNCTION** for details) to 1.

**(5) PLL**

<R> The PLL divides the PLL input clock ( $f_{PLL}$ ) by 2 after multiplies by 8 (24 MHz max.) to generate a peripheral clock ( $f_{XP}$ ).

**(6) SSCG**

<R> The SSCG multiplies the PLL input clock ( $f_{PLL}$ ) by 8 (32 MHz max.). The SSCG output clock ( $f_{SSCGO}$ ) can be selected as the main clock ( $f_{XX}$ ). Clock-through mode, in which  $f_X$  is output as is, or SSCG mode, in which  $f_{SSCGO}$  is output, can be selected by setting the PLLCTL.SELPLL bit.

In SSCG mode, the frequency modulation function can be used to effectively reduce the peak EMI noise value. Frequency modulation/no frequency modulation, the frequency modulation ratio (down spread method), and the frequency cycle can be set only once after reset.

Whether to operate or stop the SSCG can also be controlled using the SSCGCTL.SSCGON bit. Note that the setting of this bit is only valid when the PLLCTL.PLLON bit is set to 1.

The SSCG stops operating after reset.

**(7) Prescaler 1**

Prescaler 1 generates the clock to be supplied to the on-chip peripheral functions ( $f_{XP}$  to  $f_{XP}/1024$ ), using the peripheral clock ( $f_{XP}$ ) (= PLL output clock for peripheral clock ( $f_{XMPLL}$ ) divided by 2) as the source clock.

The following blocks are supplied by this clock.

<R> TMP0 to TMP8, TMQ0, TMM0 to TMM2, CSIB0 to CSIB5, CSIE0<sup>Note 1</sup>, CSIE1<sup>Note 1</sup>, UARTA0 to UARTA5,  
<R> UARTB0, UARTB1, I<sup>2</sup>C00 to I<sup>2</sup>C03, I<sup>2</sup>C04<sup>Note 1</sup>, I<sup>2</sup>C05<sup>Note 1</sup>, ADC, WDT2, CAN0<sup>Note 2</sup>, CAN1<sup>Note 3</sup>, IEBus<sup>Note 4</sup>

<R> **Notes 1.** Not available in the  $\mu$ PD70F3931 (V850E/SJ3-H), 70F3932 (V850E/SJ3-H), and 70F3933 (V850E/SJ3-H)

**2.** CAN controller versions only

**3.** CAN controller (2-channel) versions only

**4.** The IEBus controller cannot be used because the frequency of the peripheral clock supplied to the IEBus controller cannot be divided to equal a frequency of 6.29 MHz.

**(8) Prescaler 2**

This circuit divides the main clock ( $f_{XX}$ ).

The clock generated by prescaler 2 ( $f_{XX}$  to  $f_{XX}/32$ ) is supplied to the selector that generates the CPU clock ( $f_{CPU}$ ) and internal system clock ( $f_{CLK}$ ).

$f_{CLK}$  is the clock supplied to the DMAC, INTC, ROM correction, ROM, RAM, and expanded internal RAM blocks, and can be output from the CLKOUT pin.

**(9) Prescaler 3**

This circuit divides the clock generated by the main clock oscillator ( $f_X$ ) to a specific frequency and supplies that clock to the watch timer, TMM1, TMM2, and real-time counter (RTC) blocks.

For details, see **CHAPTER 10 WATCH FUNCTIONS**.

### 6.2.5 Clock mode setting

The clock mode can be set by using the SELCM2 to SELCM0 bits of the option byte 0000007BH. For details, see **CHAPTER 33 OPTION BYTE FUNCTION**.

**Caution** The clock mode cannot be changed during operation.

**Table 6-2. Clock Mode Setting**

Clock Mode	Setting of SELCM2 to SELCM0 Bits of Option Byte 0000007BH		
	SELCM2	SELCM1	SELCM0
Clock mode 1	0	0	0
Clock mode 2	1	1	1
Clock mode 3	1	0	0
Clock mode 4	1	1	0

When using clock modes 2, 3, or 4, set appropriate values to the CKC and SFC0 registers while the clock modes are in their initial status following reset release; that is, in clock-through mode and with SSCG operation stopped. At this time, also be sure to make the SSCG frequency modulation/no modulation, frequency modulation ratio (down spread method) and frequency cycle settings using the SFC1 register.

In addition, be sure to set the CKC, SFC0, and SFC1 registers only once after reset is released. These settings cannot be changed during operation.

For details of the initial settings when using clock modes 2, 3, and 4, see **6.4.4 (1) Initial settings for using clock modes 2, 3, and 4**.

### 6.3 Registers

#### (1) Processor clock control register (PCC)

The PCC register is a special register. Data can be written to this register only in combination of specific sequences (see 3.4.8 Special registers).

This register can be read or written in 8-bit or 1-bit units.

Reset sets this register to 03H.

(1/2)

After reset: 03H								R/W	Address: FFFF828H							
PCC	7	<6>		5	<4>		<3>		2	1	0					
	FRC	MCK	MFRC	CLS <sup>Note</sup>	CK3	CK2	CK1	CK0								
FRC	Use of subclock on-chip feedback resistor															
0	Used															
1	Not used															
MCK	Main clock oscillator control															
0	Oscillation enabled															
1	Oscillation stopped															
<ul style="list-style-type: none"> <li>• Even if the MCK bit is set (1) while the system is operating with the main clock as the CPU clock, the operation of the main clock does not stop. It stops after the CPU clock has been changed to the subclock.</li> <li>• Before setting the MCK bit from 0 to 1, stop the on-chip peripheral functions operating with the main clock.</li> <li>• When the main clock is stopped and the device is operating with the subclock, clear (0) the MCK bit and secure the oscillation stabilization time by software before switching the CPU clock to the main clock or operating the on-chip peripheral functions.</li> </ul>																
MFRC	Use of main clock on-chip feedback resistor															
0	Used															
1	Not used															
CLS <sup>Note</sup>	Status of CPU clock (f <sub>CPU</sub> )															
0	Main clock operation															
1	Subclock operation															
<p><b>Note</b> The CLS bit is a read-only bit.</p>																

CK3	CK2	CK1	CK0	Clock selection ( $f_{CLK}/f_{CPU}$ )
0	0	0	0	$f_{XX}$
0	0	0	1	$f_{XX}/2$
0	0	1	0	$f_{XX}/4$
0	0	1	1	$f_{XX}/8$
0	1	0	0	$f_{XX}/16$
0	1	0	1	$f_{XX}/32$
0	1	1	×	Setting prohibited
1	×	×	×	$f_{XT}$

- Cautions**
1. Do not change the CPU clock (by using the CK3 to CK0 bits) while CLKOUT is being output.
  2. When manipulating the CK3 bit, do not change the set values of the CK2 to CK0 bits.
  3. When the main clock oscillator is stopped, be sure to stop operation of the on-chip peripheral functions that are operating on the peripheral clock ( $f_{XP}$ ,  $f_{IE}$ ,  $f_{CAN}$ ).
  4. When setting subclock operation mode (CK3 bit = 1), if the following condition is not satisfied, make sure to satisfy it by changing the CK2 to CK0 bit settings before shifting to subclock operation mode.  
Internal system clock ( $f_{CLK}$ ) > Subclock ( $f_{XT}$ : 32.768 kHz) × 4

**Remark** ×: don't care

**(2) Internal oscillation mode register (RCM)**

The RCM register is an 8-bit register that sets the operation mode of the internal oscillator.

This register can be read or written in 8-bit or 1-bit units.

Reset sets this register to 00H.

After reset: 00H    R/W    Address: FFFFF80CH

	7	6	5	4	3	2	1	<0>
RCM	0	0	0	0	0	0	0	RSTOP

RSTOP	Oscillation/stop of internal oscillator
0	Internal oscillator oscillation
1	Internal oscillator stopped

- Cautions**
1. The internal oscillator cannot be stopped while the CPU is operating on the internal oscillation clock (CCLS.CCLS<sub>SF</sub> bit = 1). Do not set the RSTOP bit to 1.
  2. The internal oscillator oscillates if the CCLS.CCLS<sub>SF</sub> bit is set to 1 (when WDT overflow occurs during oscillation stabilization) even when the RSTOP bit is set to 1. At this time, the RSTOP bit remains being set to 1.
  3. The setting of the RSTOP bit is only valid when stopping the on-chip oscillator has been enabled by setting the RMOPIN bit of the option byte 0000007AH (see CHAPTER 33 OPTION BYTE FUNCTION for details) to 0. If stopping the on-chip oscillator has been disabled by setting the RMOPIN bit of the option byte 0000007AH to 1, the RSTOP bit setting is invalid.
  4. Be sure to set bits 1 to 7 to "0".

**(3) CPU operation clock status register (CCLS)**

The CCLS register indicates the status of the CPU operation clock.

This register is read-only, in 8-bit or 1-bit units.

Reset sets this register to 00H.

After reset: 00H<sup>Note</sup>    R    Address: FFFFF82EH

	7	6	5	4	3	2	1	0
CCLS	0	0	0	0	0	0	0	CCLS <sub>SF</sub>

CCLS <sub>SF</sub>	CPU operation clock status
0	Operating on main clock (f <sub>x</sub> ) or subclock (f <sub>xT</sub> ).
1	Operating on internal oscillation clock (f <sub>R</sub> ).

**Note** If WDT overflow occurs during oscillation stabilization time after a reset is released, the CPU operates on the internal oscillation clock (f<sub>R</sub>). At this time, the CCLS<sub>SF</sub> bit is set to 1 and the reset value is 01H.

**(4) PLL control register (PLLCTL)**

The PLLCTL register is an 8-bit register that controls the PLL function.

This register can be read or written in 8-bit or 1-bit units.

Reset sets this register to 01H.

After reset: 01H    R/W    Address: FFFFF82CH

	7	6	5	4	3	2	<1>	<0>
PLLCTL	0	0	0	0	0	0	SELPLL	PLLON

PLLON	PLL operation stop register
0	PLL stopped
1	PLL operating (After PLL operation starts, a lockup time is required for frequency stabilization)

SELPLL	CPU operation clock selection register
0	Clock-through mode
1	PLL mode or SSCG mode

- Cautions**
- In clock modes 2, 3, and 4, do not stop the PLL by software (i.e., do not set the PLLCTL.PLLON bit to 0).
  - When stopping PLL operation in clock mode 1, first set the clock through mode (SELPLL bit = 0), wait for at least 8 clocks, and then stop the PLL (PLLON bit = 0). When the PLLON bit is cleared to 0, the SELPLL bit is automatically cleared to 0 (clock-through mode), but be sure to stop the PLL in the above procedure.
  - When stopping SSCG operation in clock modes 2, 3, and 4, first set the clock-through mode (SELPLL bit = 0), then stop the SSCG (by setting the SSCGCTL.SSCGON bit to 0) after waiting for at least 8 clocks to elapse.
  - Set the SELPLL bit to 1 after the PLL clock frequency or SSCG clock frequency has stabilized (locked state). If the PLL frequency is not stable (LOCKR.LOCK bit = 1 (unlocked state)), even if 1 is written to the SELPLL bit, 0 will end up being written. Also, be sure to properly secure the SSCG lockup time by software.

**(5) Clock control register (CKC)**

The CKC register is a special register. Data can be written to this register only in a combination of specific sequence (see **3.4.8 Special registers**).

The CKC register sets the multiplication clock ( $f_{PLL}$ ).

This register can be read or written in 8-bit or 1-bit units.

Reset sets this register to 0AH.

After reset: 0AH R/W Address: FFFFF822H

	7	6	5	4	3	2	1	0
CKC	0	0	0	0	1	0	1	CKDIV0

CKDIV0	Selection of multiplication clock
0	$f_{PLL} = f_{PLLO}/2$ (divided by 2 after multiplication)
1	$f_{PLL} = f_{PLLO}$ or $f_{SSCGO}$ (no division after multiplication)

- Cautions**
1. The CKC.CKDIV0 bit can be switched in clock mode 1. However, when setting the CKDIV0 bit, be sure to set the clock-through mode and stop the PLL.
  2. In clock modes 2, 3, and 4, be sure to set the CKDIV0 bit to 1 (no division) immediately after reset is released, while the clock modes are still in clock-through mode (PLLCTL.SELPLL bit = 0). Set the CKC register only once after reset is released. These settings cannot be changed during operation. For details of the initial settings, see 6.4.4 (1) Initial settings for using clock modes 2, 3, and 4.
  3. Be sure to set bits 1 and 3 to "1" and set bits 2 and 4 to 7 to "0".

**Remark** When using PLL mode in clock mode 1, the peripheral clock will be identical to the main clock. Therefore, both the peripheral clock and the main clock will be subject to the division setting made by the CKDIV0 bit.

**(6) Lock register (LOCKR)**

Phase lock occurs at a given frequency following power application or immediately after the STOP mode is released, and the time required for stabilization is the lockup time (frequency stabilization time). This state until stabilization is called the lockup status, and the stabilized state is called the locked status.

The LOCKR register includes a LOCK bit that reflects the PLL frequency stabilization status.

This register is read-only, in 8-bit or 1-bit units.

Reset sets this register to 00H.

After reset: 00H    R    Address: FFFF824H

	7	6	5	4	3	2	1	<0>
LOCKR	0	0	0	0	0	0	0	LOCK

LOCK	PLL lock status check
0	Locked status
1	Unlocked status

**Caution** The LOCK register does not reflect the lock status of the PLL in real time. The set/clear conditions are as follows.

**[Set conditions]**

- Upon system reset<sup>Note</sup>
- In IDLE2 or STOP mode
- Upon setting of PLL stop (clearing of PLLCTL.PLLON bit to 0)
- Upon stopping main clock and using CPU with subclock (setting of PCC.CK3 bit to 1 and setting of PCC.MCK bit to 1)
- The main clock oscillator is not oscillating (when operating on the internal oscillation clock ( $f_{R}$ ) (CCLS.CCLSFSF bit is set to 1))

**Note** This register is set to 01H by reset and cleared to 00H after the reset has been released and the oscillation stabilization time has elapsed.

**[Clear conditions]**

- Upon overflow of oscillation stabilization time following reset release (OSTS register default time (see 26.2 (3) Oscillation stabilization time select register (OSTS)))
- Upon oscillation stabilization timer overflow (time set by OSTS register) following STOP mode release, when the STOP mode was set in the PLL operating status
- Upon PLL lockup time timer overflow (time set by PLLS register) when the PLLCTL.PLLON bit is changed from 0 to 1
- After the setup time inserted upon release of the IDLE2 mode is released (time set by the OSTS register) when the IDLE2 mode is set during PLL operation.



**(7) PLL lockup time specification register (PLLS)**

The PLLS register is an 8-bit register used to select the PLL lockup time when the PLLCTL.PLLON bit is changed from 0 to 1.

This register can be read or written in 8-bit units.

Reset sets this register to 03H.

After reset: 03H    R/W    Address: FFFFF6C1H

	7	6	5	4	3	2	1	0
PLLS	0	0	0	0	0	0	PLLS1	PLLS0

PLLS1	PLLS0	Selection of PLL lockup time
0	0	$2^{10}/f_x$
0	1	$2^{11}/f_x$
1	0	$2^{12}/f_x$
1	1	$2^{13}/f_x$ (initial value)

- Cautions**
1. Set so that the lockup time is 800  $\mu$ s or longer.
  2. Do not change the PLLS register setting during the lockup period.
  3. Be sure to set bits 2 to 7 to "0".

**(8) SSCG control register (SSCGCTL)**

The SSCGCTL register is an 8-bit register used to control the SSCG.

This register can be read or written in 8-bit or 1-bit units.

Reset sets this register to 00H.

After reset: 00H R/W Address: FFFFF3F0H

	7	6	5	4	3	2	<1>	<0>
SSCGCTL	0	0	0	0	0	0	SELSSCG	SSCGON

SELSSCG	Selection of multiplication clock ( $f_{PLL}$ ) to set main clock ( $f_{xx}$ )
0	PLL output clock ( $f_{PLLO}$ )
1	SSCG output clock ( $f_{SSCGO}$ )

SSCGON	SSCG operation control
0	SSCG stopped
1	SSCG operating (lockup time required before operation starts)

- Cautions**
1. The SSCG cannot be used in clock mode 1. Do not change the initial settings of the SSCGCTL register in this mode.
  2. In clock modes 2, 3, and 4, the PLL output clock ( $f_{PLLO}$ ) cannot be selected for the multiplication clock ( $f_{PLL}$ ).  
However, when the SSCG is stopped by setting the SSCGCTL.SSCGON bit to 0, the SSCGCTL.SELSSCG bit automatically becomes 0, causing  $f_{PLLO}$  to be selected as the multiplication clock. Consequently, when switching from SSCG mode to clock-through mode, be sure to first set the PLLCTL.SELPLL bit to 0, and then stop the SSCG by setting the SSCGON bit to 0 after switching modes. Similarly, when switching from clock-through mode to SSCG mode, first set the SSCGON bit to 1 to start up the SSCG, wait for the lockup time to elapse, then set the SELSSCG bit to 1 to select  $f_{SSCGO}$  before finally setting the SELPLL bit to 1.
  3. When the PLL is stopped (PLLCTL.PLLON bit = 0), the SSCG will not operate even if the SSCGCTL.SSCGON bit is set to 1. Note, however, that the PLL cannot be stopped in clock modes 2, 3, and 4.
  4. Be sure to set bits 2 to 7 to "0".

**(9) SSCG frequency control register 0 (SFC0)**

The SFC0 register is a special register. Data can be written to this register only in a combination of specific sequences (see **3.4.8 Special registers**).

The SFC0 register is an 8-bit register used to control the main oscillation clock frequency (fx) of the SSCG. Set the following values to this register in accordance with the clock mode used.

This register can be read or written in 8-bit units.

(address: FFFFF3F1H, initial value: 00H)

**Cautions 1. The SSCG cannot be used in clock mode 1. Do not change the initial settings of the SFC0 register in this mode.**

**2. In clock modes 2, 3, and 4, be sure to make the SFC0 register settings immediately after reset is released, while the clock modes are still in clock-through mode (PLLCTL.SELPLL bit = 0) and the SSCG is stopped (SSCGCTL.SSCGON bit = 0). In addition, be sure to set the SFC0 register only once after reset is released. These settings cannot be changed during operation. For details, see 6.4.4 (1) Initial settings for using clock modes 2, 3, and 4.**

Clock Mode		SFC0 Register Setting	PLL10 Bit Setting Value of Option Byte 0000007BH	Set SSCG Multiplication Factor/SSCG Main Oscillation Clock Frequency (fx)
<R>	Clock mode 1 (PLL output clock (x8 multiplication, 32 MHz max.) can be selected as main clock (fxx))	Setting prohibited	0	SSCG mode cannot be used.
			1	
<R>	Clock mode 2 (SSCG output clock (x12 multiplication, 48 MHz max.) can be selected as main clock (fxx))	34H	0	x12 multiplication/3.66 to 4 MHz
			1	x12 multiplication/7.32 to 8 MHz
<R>	Clock mode 3 (SSCG output clock (x8 multiplication, 32 MHz max.) can be selected as main clock (fxx))	2AH	0	x8 multiplication/3.66 to 4 MHz
			1	x8 multiplication/7.32 to 8 MHz
<R>	(SSCG output clock (x12 multiplication, 48 MHz max.) can be selected as main clock (fxx))	34H	0	x12 multiplication/3.66 to 4 MHz
			1	x12 multiplication/7.32 to 8 MHz
<R>	Clock mode 4 (SSCG output clock (x8 multiplication, 48 MHz max.) can be selected as main clock (fxx))	54H	0	x8 multiplication/5.22 to 6 MHz
			1	Setting prohibited

**(10) SSCG frequency control register 1 (SFC1)**

The SFC1 register is a special register. Data can be written to this register only in a combination of specific sequences (see **3.4.8 Special registers**).

The SFC1 register is an 8-bit register used to control the frequency modulation specification, frequency modulation ratio, and modulation cycle of the SSCG.

This register can be read or written in 8-bit units.

Reset sets this register to 00H.

After reset: 00H R/W Address: FFFF3F2H

	7	6	5	4	3	2	1	0
SFC1	SFC17	0	SFC15	SFC14	0	0	SFC11	SFC10

SFC17	SSCG frequency modulation specification
0	No modulation
1	Modulation

SFC15	SFC14	Selection of SSCG output frequency modulation ratio
0	0	-1% (TYP. value)
0	1	-2% (TYP. value)
1	0	-4% (TYP. value)
1	1	Setting prohibited



SFC11	SFC10	Selection of SSCG output modulation cycle
0	0	40 kHz (TYP. value)
0	1	50 kHz (TYP. value)
1	0	60 kHz (TYP. value)
1	1	Setting prohibited

- Cautions**
1. The SSCG cannot be used in clock mode 1. Do not change the initial settings of the SFC1 register in this mode.
  2. In clock modes 2, 3, and 4, be sure to make the SFC1 register settings immediately after reset is released, while the clock modes are still in clock-through mode (PLLCTL.SELPLL bit = 0) and the SSCG is stopped (SSCGCTL.SSCGON bit = 0). In addition, be sure to set the SFC1 register only once after reset is released. These settings cannot be changed during operation. For details, see 6.4.4 (1) Initial settings for using clock modes 2, 3, and 4.
  3. Be sure to set bits 2, 3, and 6 to "0".

## 6.4 Operation

### 6.4.1 Operation of each clock

The operating status of each clock is shown in the table below.

**Table 6-3. Clock Operating Statuses**

Register Setting and Operating Status Target Clock	CLS bit = 0, MCK bit = 0, SELPLL bit = 0									CLS bit = 0, MCK bit = 0, SELPLL bit = 1									CLS bit = 1, MCK bit = 0, SELPLL bit = 0/1			CLS bit = 1, MCK bit = 1, SELPLL bit = 0/1	
	<1>	<2>	<3>	<4>	<5>	<6>	<7>	<8>	<9>	<3>	<4>	<5>	<6>	<7>	<8>	<9>	<2>	<10>	<11>	<10>	<11>		
Main clock oscillator (fx)	x	√	√	√	√	√	√	x	√	√	√	√	√	√	x	√	√	√	√	x	x		
Subclock oscillator (fxT)	√	√	√	√	√	√	√	√	√	√	√	√	√	√	√	√	√	√	√	√	√		
CPU clock (fcPU)	x	x→√ Note 1	√	x	x	x	x→√ Note 2	x	x→√ Note 1	√	x	x	x	x→√ Note 2	x	x→√ Note 1	√	√	x	√	x		
Main clock (fxx)	x	x→√ Note 1	√	√	x	x	√	x	x→√ Note 1	√	√	x	x	x→√ Note 2	x	x→√ Note 1	x→√ Note 1	√	x	x	x		
Internal system clock (fCLK)	x	x→√ Note 1	√	√	x	x	x→√ Note 2	x	x→√ Note 1	√	√	x	x	x→√ Note 2	x	x→√ Note 1	√	√	x	√	x		
Peripheral clock (fxP to fxP/1024)	x	x	√	√	x	x	x	x	x	√	√	x	x	x	x	x	x	√	x	x	x		
WT clock (main)	x	x→√ Note 1	√	√	√	√	√	x	x→√ Note 1	√	√	√	√	√	x	x→√ Note 1	x→√ Note 1	√	√	x	x		
WT clock (sub)	√	√	√	√	√	√	√	√	√	√	√	√	√	√	√	√	√	√	√	√	√		
WDT2 clock (on-chip oscillation)	x	√	√	√	√	√	√	√	√	√	√	√	√	√	√	√	√	√	√	√	√		
WDT2 clock (main)	x	x	√	√	x	x	x	x	x	√	√	x	x	x	x	x	x	√	x	x	x		
WDT2 clock (sub)	√	√	√	√	√	√	√	√	√	√	√	√	√	√	√	√	√	√	√	√	√		

- <1> RESET pin input
- <2> During counting of oscillation stabilization time
- <3> Main clock operation mode
- <4> HALT mode
- <5> IDLE1 mode
- <6> IDLE2 mode
- <7> During counting of setup time after IDLE2 mode release
- <8> STOP mode
- <9> During counting of oscillation stabilization time after STOP mode release
- <10> Subclock operation mode
- <11> Sub-IDLE mode

**Notes 1.** x changes to √ after the oscillation stabilization time has elapsed.  
**2.** x changes to √ after the setup time has elapsed.

**Remark** √: Operable  
x: Stopped

### 6.4.2 Clock output function

The clock output function is used to output the internal system clock ( $f_{CLK}$ ) from the CLKOUT pin.

The internal system clock ( $f_{CLK}$ ) is selected by using the PCC.CK3 to PCC.CK0 bits.

The CLKOUT pin shares pin with the PCM1 pin and functions as a clock output pin if so specified by the control register of port CM.

The status of the CLKOUT pin is the same as the internal system clock in Table 6-3 and the pin can output the clock when it is in the operable status. It outputs a low level in the stopped status. However, the CLKOUT pin is in the port mode (PCM1 pin: input mode) after reset and until it is set in the output mode. Therefore, the status of the pin is high impedance.

## 6.4.3 Procedure for setting clock generation function for using clock mode 1

Figure 6-5. Procedure for Setting Clock Generation Function for Using Clock Mode 1

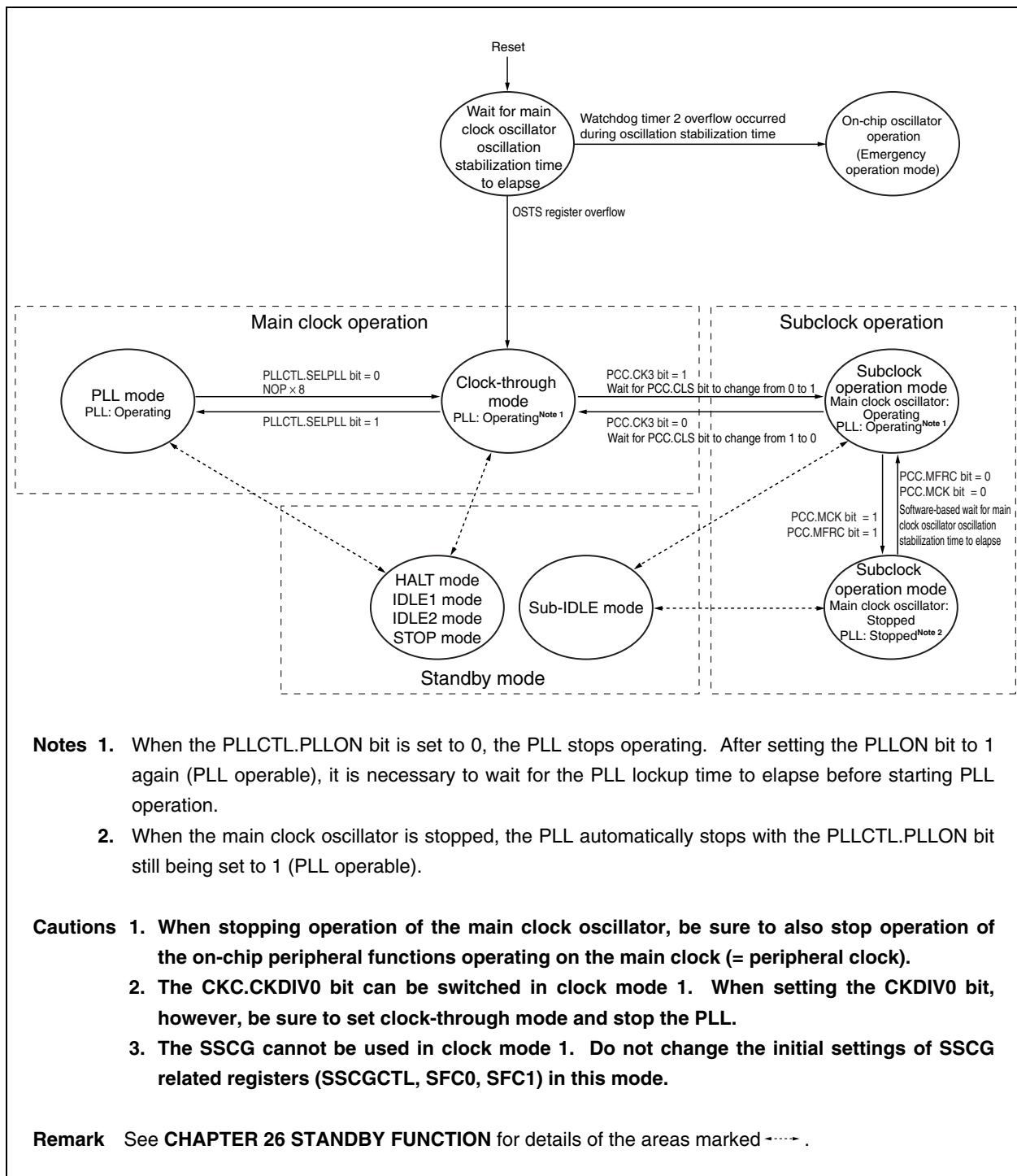

**(1) Switching from clock-through mode to PLL mode**

- <1> PLLS register setting: Lockup time selection  
Set so that the lockup time is 800  $\mu$ s or longer.
- <2> PLLCTL.PLLON bit  $\leftarrow$  1: PLL operation enabled
- <3> Wait until LOCKR.LOCK bit = 0: Wait for PLL lockup time to elapse
- <4> PLLCTL.SELPLL bit  $\leftarrow$  1: Multiplication clock ( $f_{PLL} = f_{PLO}$ ) selected as main clock ( $f_{XX}$ ) (PLL mode)

**Caution** When the PLL is stopped (PLLCTL.PLLON bit = 0), settings <1> to <3> are necessary. If the PLL is already operating and the lockup time has elapsed, only setting <4> is needed to switch to PLL mode. The PLL is in the locked state after reset release.

**(2) Switching from PLL mode to clock-through mode**

- <1> PLLCTL.SELPLL bit  $\leftarrow$  0: Main oscillation clock ( $f_x$ ) selected as main clock (clock-through mode)
- <2> Execute 8 NOP instructions
- <3> PLLCTL.PLLON bit  $\leftarrow$  0: Setting the PLLON bit to 0 stops the PLL

**(3) Switching from main clock operation to subclock operation**

- <1> PCC.CK3 bit  $\leftarrow$  1: Setting via a bit manipulation instruction recommended.  
Do not change the setting of the PCC.CK2 to PCC.CK0 bits.
- <2> Subclock operation: Check whether the system has switched to subclock operation by reading the PCC.CLS bit.  
The time required until the system switches to subclock operation after setting the CK3 bit is shown below.  
Maximum:  $1/f_{XT}$  (1/subclock frequency)
- <3> PCC.MCK bit  $\leftarrow$  1: Set the MCK bit to 1 only when the main clock oscillator is stopped.

**Cautions**

1. When stopping operation of the main clock oscillator, be sure to also stop operation of the on-chip peripheral functions operating on the main clock (= peripheral clock).
2. If the following condition is not satisfied, make sure to satisfy it by changing the PCC.CK2 to PCC.CK0 bit settings before shifting to subclock operation mode.  
Internal system clock ( $f_{CLK}$ ) > Subclock ( $f_{XT}$ : 32.768 kHz)  $\times$  4

**Remark** Internal system clock ( $f_{CLK}$ ): Clock generated from the main clock ( $f_{XX}$ ) by setting the PCC.CK2 to PCC.CK0 bits.



**(4) Switching from subclock operation to main clock operation**

- <1> PCC.MCK bit ← 0: Start of main clock oscillation
- <2> Insert a wait by a program and wait for the main clock oscillation stabilization time to elapse.
- <3> PCC.CK3 bit ← 0: Setting via a bit manipulation instruction recommended. Do not change the setting of the PCC.CK2 to PCC.CK0 bits.
- <4> Main clock operation: The time required until the system switches to main clock operation after setting the CK3 bit is shown below.
  - Maximum:  $1/f_{XT}$  (1/subclock frequency)
  - It is therefore necessary to either insert one NOP instruction immediately after setting the CK3 bit to 0, or check whether the system has switched to main clock operation by reading the PCC.CLS bit.

**Caution** Enable operation of the on-chip peripheral functions that operate on the main clock (= peripheral clock) after ensuring that main clock oscillation is stable. If operation of these functions is enabled before the main clock's oscillation stabilization time has elapsed, a malfunction may occur.

6.4.4 Procedure for setting clock generation function for using clock modes 2, 3, and 4

Figure 6-6. Procedure for Setting Clock Generation Function for Using Clock Modes 2, 3, and 4

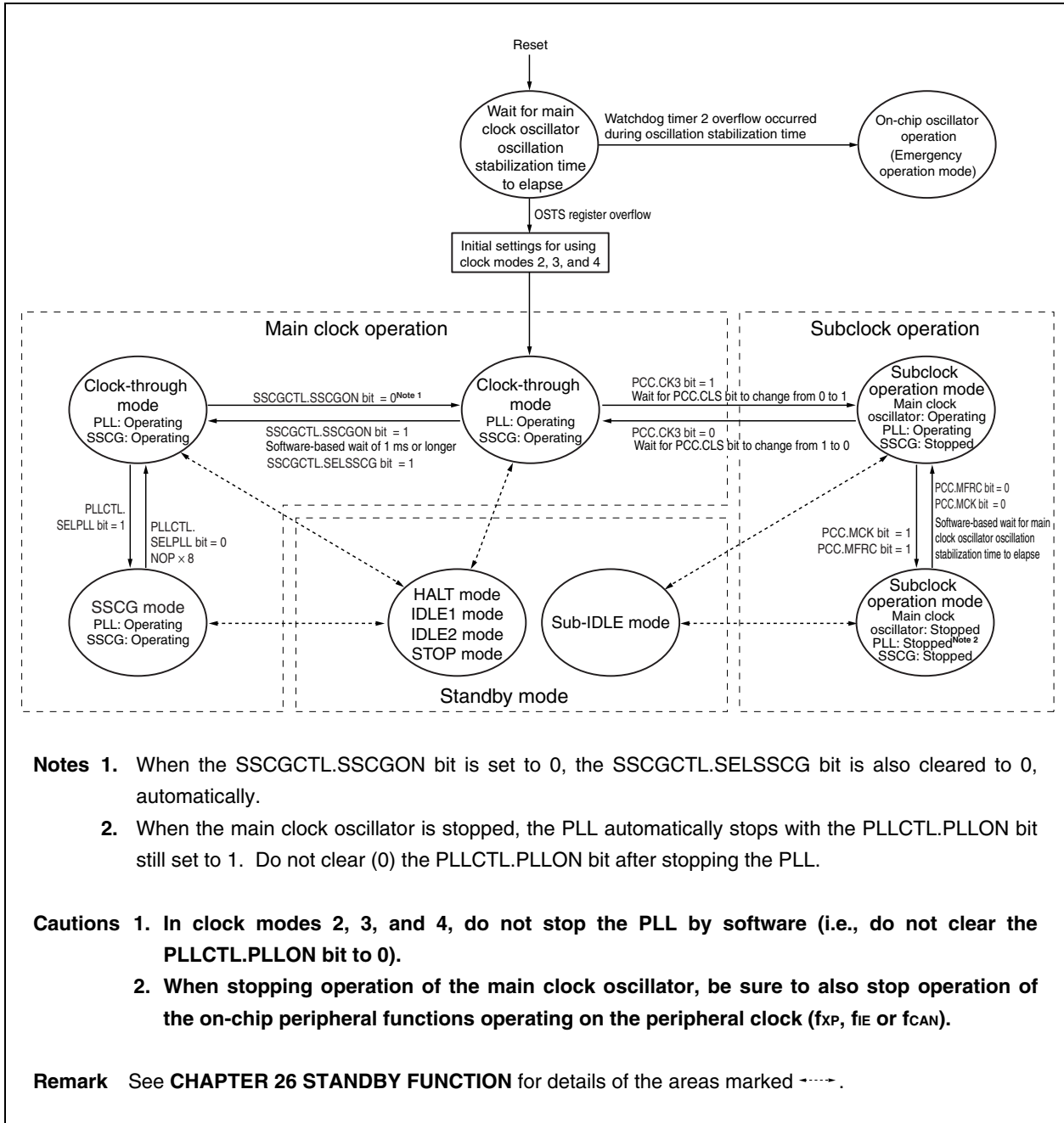

**(1) Initial settings for using clock modes 2, 3, and 4**

When using clock modes 2, 3, or 4, set appropriate values to the CKC and SFC0 registers while the clock modes are in their initial status following reset release; that is, in clock-through mode and with SSCG operation stopped. At this time, also be sure to make the SSCG frequency modulation/no modulation, frequency modulation ratio (down spread method) and frequency cycle settings using the SFC1 register.

Note that in clock modes 2, 3, and 4, the settings of the CKC, SFC0 and SFC1 registers can only be made once after reset is released. These settings cannot be changed during operation.

- Cautions**
- 1. In clock modes 2, 3, and 4, always set the CKC, SFC0 and SFC1 registers in the status immediately after reset release; that is, in clock-through mode (PLLCTL.SELPLL bit = 0) and with SSCG operation stopped.**
  - 2. Set the CKC, SFC0, and SFC1 registers only once after reset is released. These settings cannot be changed during operation.**
  - 3. Be sure to insert a 1  $\mu$ s wait time after setting the CKC, SFC0, and SFC1 registers.**

**Figure 6-7. Flow of Initialization Processing for Using Clock Modes 2, 3, and 4**

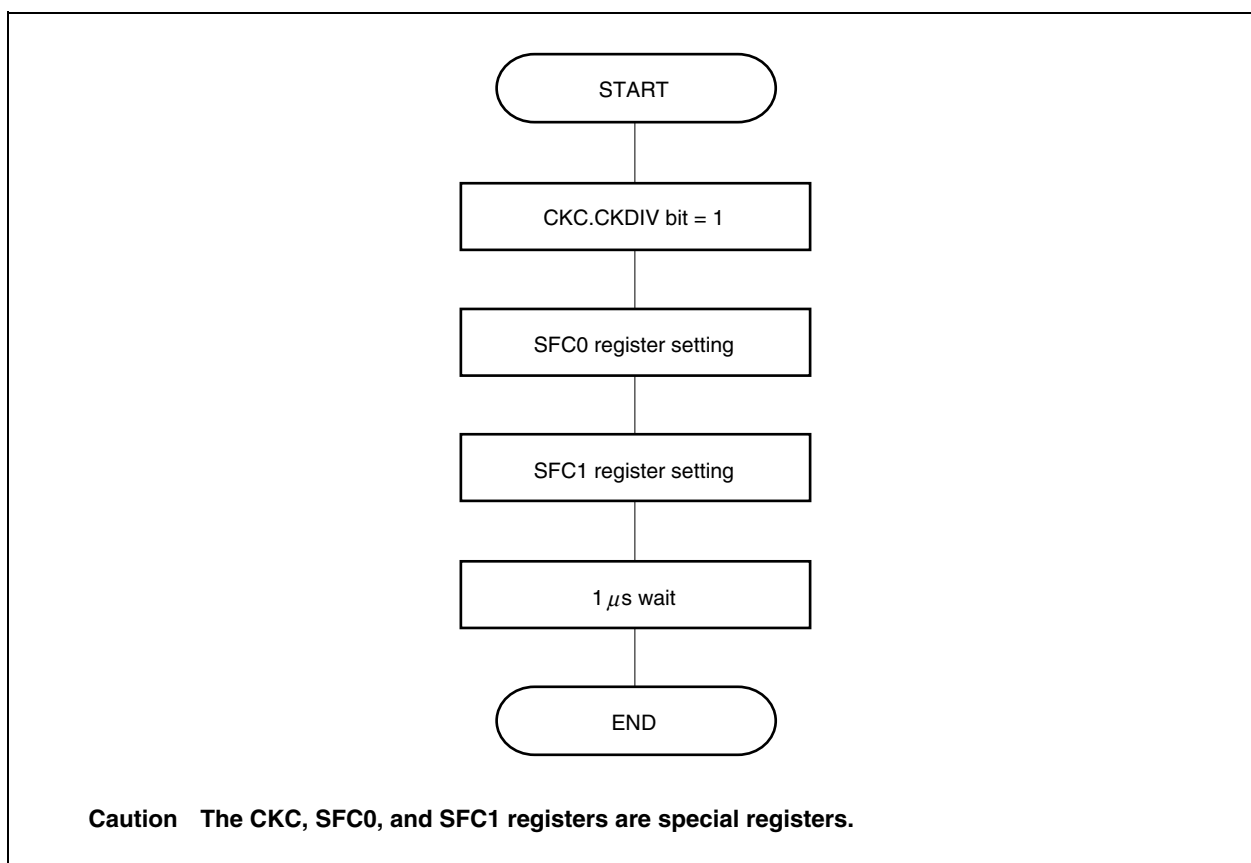

**(2) Switching from clock-through mode to SSCG mode**

- <1> SSCGCTL.SSCGON bit ← 1: SSCG operation enabled
- <2> Software-based wait of 1 ms or longer: Wait for SSCG lockup time to elapse
- <3> SSCGCTL.SELSSCG bit ← 1: Multiplication clock ( $f_{PLL}$ ) selected as SSCG output clock ( $f_{SSCGO}$ )
- <4> PLLCTL.SELPLL bit ← 1: Multiplication clock ( $f_{PLL} = f_{SSCGO}$ ) selected as main clock ( $f_{xx}$ ) (SSCG mode)

**Cautions** 1. The SSCG is stopped following reset release, so settings <1> to <3> are necessary. If the SSCG is already operating and the lockup time has elapsed, only setting <4> is needed to switch to SSCG mode.

2. Do not stop operation of the PLL (i.e., do not clear the PLLCTL.PLLON bit to 0).

**(3) Switching from SSCG mode to clock-through mode**

- <1> PLLCTL.SELPLL bit ← 0: Main oscillation clock ( $f_x$ ) selected as main clock ( $f_{xx}$ ) (clock-through mode)
- <2> Execute 8 NOP instructions.
- <3> SSCGCTL.SSCGON bit ← 0: Setting the SSCGON bit to 0 stops the SSCG.

**Cautions** 1. When the SSCGCTL.SSCGON bit is set to 0, the SSCGCTL.SELSSCG bit is also cleared to 0, automatically.

2. Do not stop operation of the PLL (i.e., do not clear the PLLCTL.PLLON bit to 0).

**(4) Switching from main clock operation to subclock operation**

- <1> PCC.CK3 bit ← 1: Setting via a bit manipulation instruction recommended.  
Do not change the setting of the PCC.CK2 to PCC.CK0 bits.
- <2> Subclock operation: Check whether the system has switched to subclock operation by reading the PCC.CLS bit.  
The time required until the system switches to subclock operation after setting the CK3 bit is shown below.  
Maximum:  $1/f_{XT}$  (1/subclock frequency)
- <3> PCC.MCK bit ← 1: Set the MCK bit to 1 only when the main clock oscillator is stopped.

**Cautions** 1. When switching the system to subclock operation, first switch to clock-through mode and stop operation of the SSCG.

2. When stopping operation of the main clock oscillator, be sure to also stop operation of the on-chip peripheral functions operating on the peripheral clock ( $f_{XP}$ ,  $f_{IE}$ , and  $f_{CAN}$ ).

3. Do not stop operation of the PLL by software. When the main clock oscillator is stopped, the PLL automatically stops with the PLLCTL.PLLON bit still set to 1 (PLL operable). Do not clear (0) the PLLCTL.PLLON bit after stopping the PLL.

4. If the following condition is not satisfied, make sure to satisfy it by changing the PCC.CK2 to PCC.CK0 bit settings before shifting to subclock operation mode.

$$\text{Internal system clock } (f_{CLK}) > \text{Subclock } (f_{XT}: 32.768 \text{ kHz}) \times 4$$

**Remark** Internal system clock ( $f_{CLK}$ ): Clock generated from the main clock ( $f_{XX}$ ) by setting the PCC.CK2 to PCC.CK0 bits.

**(5) Switching from subclock operation to main clock operation**

- <1> PCC.MCK bit ← 0: Start of main clock oscillation
- <2> Insert a wait by a program and wait for the main clock oscillation stabilization time to elapse.
- <3> PCC.CK3 bit ← 0: Setting via a bit manipulation instruction recommended. Do not change the setting of the PCC.CK2 to PCC.CK0 bits.
- <4> Main clock operation: The time required until the system switches to main clock operation after setting the CK3 bit is shown below.
  - Maximum:  $1/f_{XT}$  (1/subclock frequency)
  - It is therefore necessary to either insert one NOP instruction immediately after setting the CK3 bit to 0, or check whether the system has switched to main clock operation by reading the PCC.CLS bit.

- Cautions**
1. Enable operation of the on-chip peripheral functions that operate on the peripheral clock ( $f_{XP}$ ,  $f_{IE}$ , and  $f_{CAN}$ ) after ensuring that main clock oscillation is stable. If operation of these functions is enabled before the main clock's oscillation stabilization time has elapsed, a malfunction may occur.
  2. Enable operation of the SSCG after switching to main clock operation.

## CHAPTER 7 16-BIT TIMER/EVENT COUNTER P (TMP)

Timer P (TMP) is a 16-bit timer/event counter.

The V850E/SJ3-H and V850E/SK3-H have nine timer/event counter channels, TMP0 to TMP8.

### 7.1 Overview

#### 7.1.1 TMP0 to TMP6

An outline of TMP0 to TMP6 are shown below.

- Clock selection: 8 ways
- Capture/trigger input pins: 2
- External event count input pin: 1
- External trigger input pin: 1
- Timer/counter: 1
- Capture/compare registers: 2
- Capture/compare match interrupt request signals: 2
- Overflow interrupt request signal: 1
- Timer output pins: 2

#### 7.1.2 TMP7 and TMP8

An outline of TMP7 and TMP8 are shown below.

- Clock selection: 8 ways
- Capture/trigger input pins: 2
- External event count input pin: 1
- External trigger input pin: 1
- Encoder input pins: 2
- Encoder clear input pin: 1
- Timer/counter: 1
- Capture/compare registers: 2
- Capture/compare match interrupt request signals: 2
- Overflow interrupt request signal: 1
- Encoder clear interrupt request signal: 1
- Timer output pins: 2

## 7.2 Functions

### 7.2.1 TMP0 to TMP6

TMP0 to TMP6 have the following functions.

- Interval timer
- External event counter
- External trigger pulse output
- One-shot pulse output
- PWM output
- Free-running timer
- Pulse width measurement

### 7.2.2 TMP7 and TMP8

TMP7 and TMP8 have the following functions.

- Interval timer
- External event counter
- External trigger pulse output
- One-shot pulse output
- PWM output
- Free-running timer
- Pulse width measurement
- Encoder count function

## 7.3 Configuration

### 7.3.1 TMP0 to TMP6

TMP0 to TMP6 include the following hardware.

**Table 7-1. Configuration of TMP0 to TMP6**

Item	Configuration
Timer register	16-bit counter
Registers	TMPk capture/compare registers 0, 1 (TPkCCR0, TPkCCR1) TMPk counter read buffer register (TPkCNT) CCR0, CCR1 buffer registers
Timer inputs	2 (TIPk0 <sup>Note 1</sup> , TIPk1 pins)
Timer outputs	2 (TOPk0, TOPk1 pins)
Control registers <sup>Note 2</sup>	TMPk control registers 0, 1 (TPkCTL0, TPkCTL1) TMPk I/O control registers 0 to 2 (TPkIOC0 to TPkIOC2) TMPk option register 0 (TPkOPT0)

- Notes**
1. The TIPk0 pin functions alternately as a capture trigger input signal, external event count input signal, and external trigger input signal.
  2. When using the functions of the TIPk0, TIPk1, TOPk0, and TOPk1 pins, refer to **Table 4-25 Using Port Pin as Alternate-Function Pin**.

**Remark** k = 0 to 6



Figure 7-1. Block Diagram of TMPk

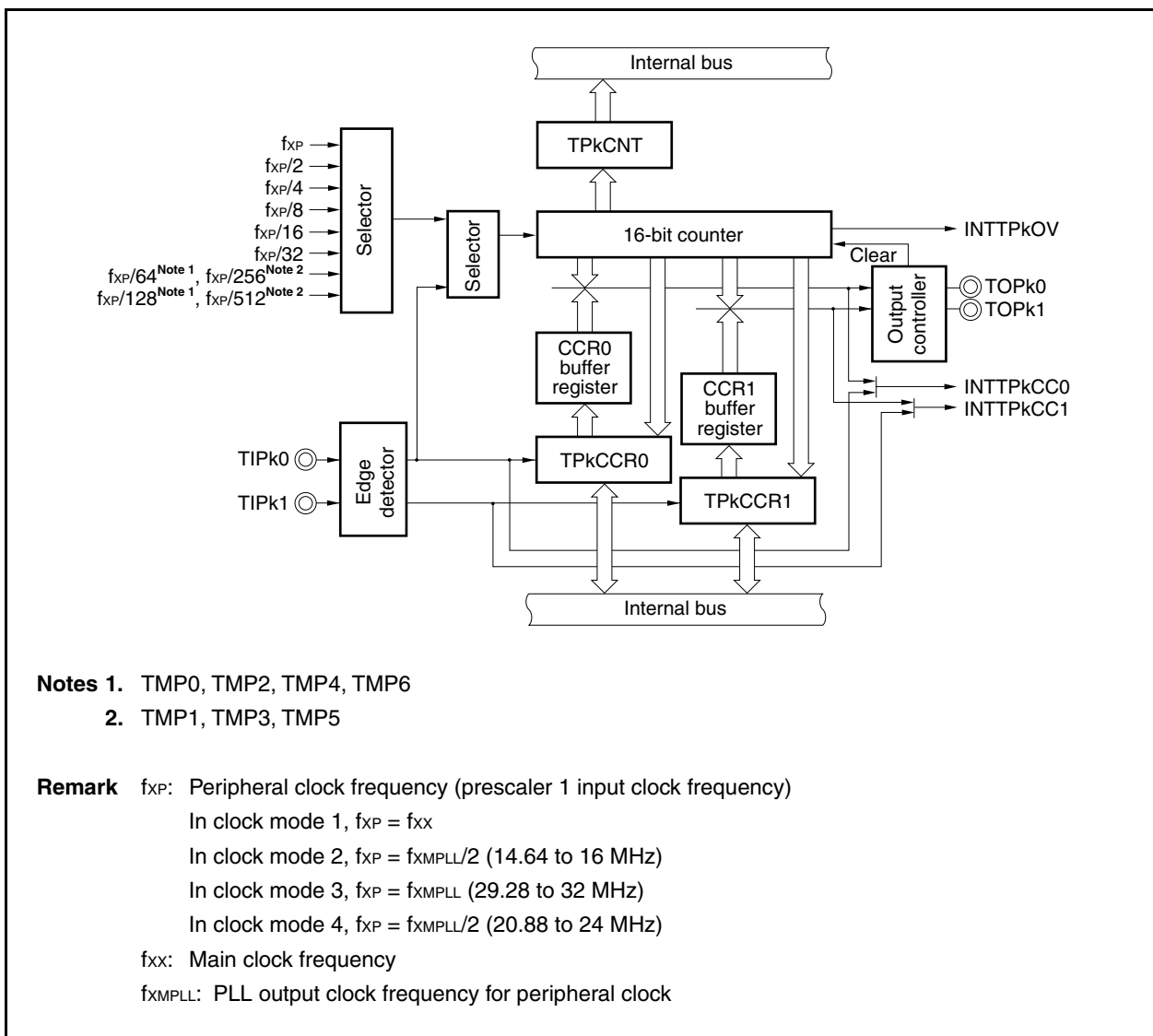

**(1) 16-bit counter**

This 16-bit counter can count internal clocks or external events.

The count value of this counter can be read by using the TPkCNT register.

When the TPkCTL0.TPkCE bit = 0, the value of the 16-bit counter is FFFFH. If the TPkCNT register is read at this time, 0000H is read.

Reset sets the TPkCE bit to 0.

**(2) CCR0 buffer register**

This is a 16-bit compare register that compares the count value of the 16-bit counter.

When the TPkCCR0 register is used as a compare register, the value written to the TPkCCR0 register is transferred to the CCR0 buffer register. When the count value of the 16-bit counter matches the value of the CCR0 buffer register, a compare match interrupt request signal (INTTPkCC0) is generated.

The CCR0 buffer register cannot be read or written directly.

The CCR0 buffer register is cleared to 0000H after reset, as the TPkCCR0 register is cleared to 0000H.

**(3) CCR1 buffer register**

This is a 16-bit compare register that compares the count value of the 16-bit counter.

When the TPkCCR1 register is used as a compare register, the value written to the TPkCCR1 register is transferred to the CCR1 buffer register. When the count value of the 16-bit counter matches the value of the CCR1 buffer register, a compare match interrupt request signal (INTTPkCC1) is generated.

The CCR1 buffer register cannot be read or written directly.

The CCR1 buffer register is cleared to 0000H after reset, as the TPkCCR1 register is cleared to 0000H.

**(4) Edge detector**

This circuit detects the valid edges input to the TIPk0 and TIPk1 pins. No edge, rising edge, falling edge, or both the rising and falling edges can be selected as the valid edge by using the TPkIOC1 and TPkIOC2 registers.

**(5) Output controller**

This circuit controls the output of the TOPk0 and TOPk1 pins. The output controller is controlled by the TPkIOC0 register.

**(6) Selector**

This selector selects the count clock for the 16-bit counter. Eight types of internal clocks or an external event can be selected as the count clock.

### 7.3.2 TMP7 and TMP8

TMP7 and TMP8 include the following hardware.

**Table 7-2. Configuration of TMP7 and TMP8**

Item	Configuration
Timer register	16-bit counter
Registers	TMPm capture/compare registers 0, 1 (TPmCCR0, TPmCCR1) TMPm counter read buffer register (TPmCNT) TMPm counter write register (TPmTCW) CCR0, CCR1 buffer registers
Timer inputs	5 (TIPm0 <sup>Note 1</sup> , TIPm1, TECRm, TENCm0, TENCm1 pins)
Timer outputs	2 (TOPm0, TOPm1 pins)
Control registers <sup>Note 2</sup>	TMPm control registers 0, 1 (TPmCTL0, TPmCTL1) TMPm control register 2 (TPmCTL2) TMPm I/O control registers 0 to 3 (TPmIOC0 to TPmIOC3) TMPm option register 0 (TPmOPT0) TMPm option register 1 (TPmOPT1) TMPa noise elimination control register (ENaNFC)

**Notes 1.** The TIPm0 pin functions alternately as a capture trigger input signal, external event count input signal, and external trigger input signal.

**2.** When using the functions of the TIPm0, TIPm1, TOPm0, TOPm1, TECRm, TENCm0, and TENCm1 pins, refer to **Table 4-25 Using Port Pin as Alternate-Function Pin**.

**Remark** m = 7, 8  
a = 0, 1

Figure 7-2. Block Diagram of TMP7 and TMP8

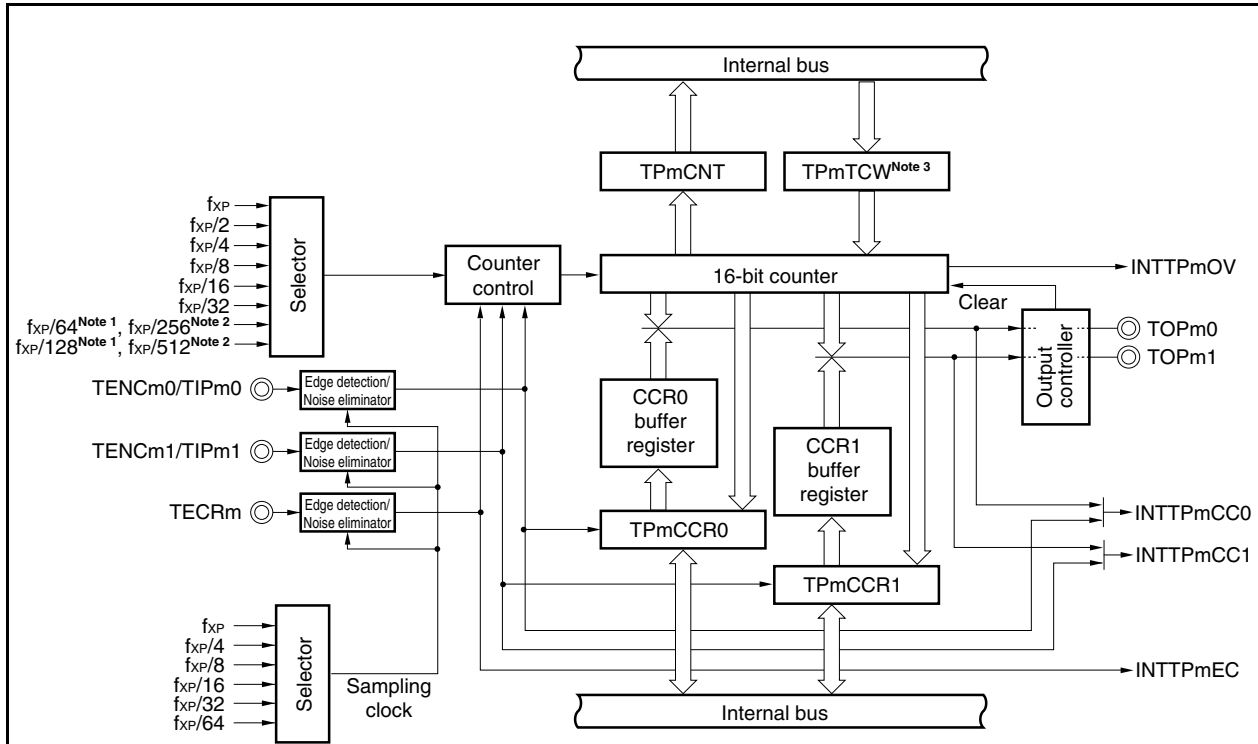
**Notes 1.** TMP8**2.** TMP7

- 3.** The initial value set from the TPmTCW register to the 16-bit counter is valid only in the encoder compare mode.

Rewrite the TPmTCW register when the TPmCTL0.TPmCE bit = 0.

When the TPmCTL2.TPmECC bit = 0, the value of the TPmTCW register is transferred to the 16-bit counter when the TPmCE bit = 1.

**Remarks 1.**  $f_{XP}$ : Peripheral clock frequency (prescaler 1 input clock frequency)

In clock mode 1,  $f_{XP} = f_{XX}$

In clock mode 2,  $f_{XP} = f_{XMPLL}/2$  (14.64 to 16 MHz)

In clock mode 3,  $f_{XP} = f_{XMPLL}$  (29.28 to 32 MHz)

In clock mode 4,  $f_{XP} = f_{XMPLL}/2$  (20.88 to 24 MHz)

$f_{XX}$ : Main clock frequency

$f_{XMPLL}$ : PLL output clock frequency for peripheral clock

- 2.**  $m = 7, 8$

**(1) 16-bit counter**

This 16-bit counter can count internal clocks or external events.

The count value of this counter can be read by using the TPmCNT register.

When the TPmCTL0.TPmCE bit = 0, the value of the 16-bit counter is FFFFH. If the TPmCNT register is read at this time, 0000H is read.

Reset sets the TPmCE bit to 0.

**(2) CCR0 buffer register**

This is a 16-bit compare register that compares the count value of the 16-bit counter.

When the TPmCCR0 register is used as a compare register, the value written to the TPmCCR0 register is transferred to the CCR0 buffer register. When the count value of the 16-bit counter matches the value of the CCR0 buffer register, a compare match interrupt request signal (INTTPmCC0) is generated.

The CCR0 buffer register cannot be read or written directly.

The CCR0 buffer register is cleared to 0000H after reset, as the TPmCCR0 register is cleared to 0000H.

**(3) CCR1 buffer register**

This is a 16-bit compare register that compares the count value of the 16-bit counter.

When the TPmCCR1 register is used as a compare register, the value written to the TPmCCR1 register is transferred to the CCR1 buffer register. When the count value of the 16-bit counter matches the value of the CCR1 buffer register, a compare match interrupt request signal (INTTPmCC1) is generated.

The CCR1 buffer register cannot be read or written directly.

The CCR1 buffer register is cleared to 0000H after reset, as the TPmCCR1 register is cleared to 0000H.

**(4) Edge detector**

This circuit detects the valid edges input to the TIPm0, TIPm1, TECRm, TENCm0, and TENCm1 pins. No edge, rising edge, falling edge, or both the rising and falling edges can be selected as the valid edge by using the TPmIOC1, TPmIOC2, and TPmIOC3 registers.

**(5) Output controller**

The output of the TOPm0 and TOPm1 pins is controlled by the TPmIOC0 register.

**(6) Selector**

This selector selects the count clock for the 16-bit counter. Eight types of internal clocks or an external event can be selected as the count clock.

**(7) Counter controller**

This controls the count operation according to the timer mode selected in the TPmCTL1 register.

## 7.4 Registers

The registers that control TMP<sub>n</sub> are as follows.

- TMP<sub>n</sub> control register 0 (TPnCTL0)
- TMP<sub>n</sub> control register 1 (TPnCTL1)
- TMP<sub>m</sub> control register 2 (TPmCTL2)
- TMP<sub>n</sub> I/O control register 0 (TPnIOC0)
- TMP<sub>n</sub> I/O control register 1 (TPnIOC1)
- TMP<sub>n</sub> I/O control register 2 (TPnIOC2)
- TMP<sub>m</sub> I/O control register 3 (TPmIOC3)
- TMP<sub>n</sub> option register 0 (TPnOPT0)
- TMP<sub>m</sub> option register 1 (TPmOPT1)
- TMP<sub>n</sub> capture/compare register 0 (TPnCCR0)
- TMP<sub>n</sub> capture/compare register 1 (TPnCCR1)
- TMP<sub>m</sub> counter write register (TPmTCW)
- TMP<sub>n</sub> counter read buffer register (TPnCNT)
- TMP<sub>a</sub> noise elimination control register (ENaNFC)

**Remarks 1.** When using the functions of the TIP<sub>n0</sub>, TIP<sub>n1</sub>, TOP<sub>n0</sub>, TOP<sub>n1</sub>, TECR<sub>m</sub>, TENC<sub>m0</sub>, and TENC<sub>m1</sub> pins, refer to **Table 4-25 Using Port Pin as Alternate-Function Pin.**

2. n = 0 to 8  
m = 7, 8  
a = 0, 1

**(1) TMPn control register 0 (TPnCTL0)**

The TPnCTL0 register is an 8-bit register that controls the operation of TMPn.

This register can be read or written in 8-bit or 1-bit units.

Reset sets this register to 00H.

The same value can always be written to the TPnCTL0 register by software.

After reset: 00H    R/W    Address:    TP0CTL0 FFFFF590H, TP1CTL0 FFFFF5A0H,  
 TP2CTL0 FFFFF5B0H, TP3CTL0 FFFFF5C0H,  
 TP4CTL0 FFFFF5D0H, TP5CTL0 FFFFF5E0H,  
 TP6CTL0 FFFFF5F0H, TP7CTL0 FFFFF640H,  
 TP8CTL0 FFFFF660H

	<7>	6	5	4	3	2	1	0
TPnCTL0 (n = 0 to 8)	TPnCE	0	0	0	0	TPnCKS2	TPnCKS1	TPnCKS0

TPnCE	TMPn operation control
0	TMPn operation disabled (TMPn reset asynchronously <sup>Note</sup> ).
1	TMPn operation enabled. TMPn operation started.

TPnCKS2	TPnCKS1	TPnCKS0	Internal count clock selection	
			n = 0, 2, 4, 6, 8	n = 1, 3, 5, 7
0	0	0	f <sub>XP</sub>	
0	0	1	f <sub>XP</sub> /2	
0	1	0	f <sub>XP</sub> /4	
0	1	1	f <sub>XP</sub> /8	
1	0	0	f <sub>XP</sub> /16	
1	0	1	f <sub>XP</sub> /32	
1	1	0	f <sub>XP</sub> /64	f <sub>XP</sub> /256
1	1	1	f <sub>XP</sub> /128	f <sub>XP</sub> /512

**Note** The TPnOPT0.TPnOVF bit and 16-bit counter are reset at the same time. In addition, the timer output pins (TOPn0 and TOPn1 pins) are reset to the status set by the TPnIOC0 register when the 16-bit counter is reset.

- Cautions**
1. Set the TPnCKS2 to TPnCKS0 bits when the TPnCE bit = 0. When the value of the TPnCE bit is changed from 0 to 1, the TPnCKS2 to TPnCKS0 bits can be set simultaneously.
  2. Be sure to clear bits 3 to 6 to “0”.

**Remark** f<sub>XP</sub>: Peripheral clock frequency (prescaler 1 input clock frequency)  
 In clock mode 1, f<sub>XP</sub> = f<sub>XX</sub>  
 In clock mode 2, f<sub>XP</sub> = f<sub>XMPLL</sub>/2 (14.64 to 16 MHz)  
 In clock mode 3, f<sub>XP</sub> = f<sub>XMPLL</sub> (29.28 to 32 MHz)  
 In clock mode 4, f<sub>XP</sub> = f<sub>XMPLL</sub>/2 (20.88 to 24 MHz)  
 f<sub>XX</sub>: Main clock frequency  
 f<sub>XMPLL</sub>: PLL output clock frequency for peripheral clock

**(2) TMPn control register 1 (TPnCTL1)**

The TPnCTL1 register is an 8-bit register that controls the operation of TMPn.

This register can be read or written in 8-bit or 1-bit units.

Reset sets this register to 00H.

(1/2)

After reset: 00H    R/W    Address: TP0CTL1 FFFFF591H, TP1CTL1 FFFFF5A1H,  
 TP2CTL1 FFFFF5B1H, TP3CTL1 FFFFF5C1H,  
 TP4CTL1 FFFFF5D1H, TP5CTL1 FFFFF5E1H,  
 TP6CTL1 FFFFF5F1H, TP7CTL1 FFFFF641H,  
 TP8CTL1 FFFFF661H

	7	<6>	<5>	4	3	2	1	0
TPnCTL1	0	TPnEST	TPnEEE	0	TPmMD3	TPnMD2	TPnMD1	TPnMD0

$\left. \begin{matrix} n = 0 \text{ to } 8 \\ m = 7, 8 \end{matrix} \right\}$

TPnEST	Software trigger control
0	–
1	Generate a valid signal for external trigger input. <ul style="list-style-type: none"> <li>In one-shot pulse output mode: A one-shot pulse is output with writing 1 to the TPnEST bit as the trigger.</li> <li>In external trigger pulse output mode: A PWM waveform is output with writing 1 to the TPnEST bit as the trigger.</li> </ul>
The read value of the TPnEST bit is always 0.	

TPnEEE	Count clock selection
0	Disable operation with external event count input (TIPn0 pin). (Perform counting with the count clock selected by the TPnCTL0.TPnCKS0 to TPnCKS2 bits.)
1	Enable operation with external event count input (TIPn0 pin). (Perform counting at the valid edge of the external event count input signal (TIPn0 pin).)
The TPnEEE bit selects whether counting is performed with the internal count clock or the valid edge of the external event count input.	

TPmMD3	TPmMD2	TPmMD1	TPmMD0	Timer mode selection
0	0	0	0	Interval timer mode
0	0	0	1	External event count mode
0	0	1	0	External trigger pulse output mode
0	0	1	1	One-shot pulse output mode
0	1	0	0	PWM output mode
0	1	0	1	Free-running timer mode
0	1	1	0	Pulse width measurement mode
1	0	0	0	Encoder compare mode
Other than above				Setting prohibited



- Cautions**
1. The TPnEST bit is valid only in the external trigger pulse output mode or one-shot pulse output mode. In any other mode, writing 1 to this bit is ignored.
  2. The TPnEEE bit is valid only in the interval timer mode, external trigger pulse output mode, one-shot pulse output mode, PWM output mode, free-running timer mode, or pulse width measurement mode. In any other mode, writing 1 to this bit is ignored.
  3. External event count input (TIPn0) or encoder inputs (TENCm0, TENCm1) is selected in the external event count mode or encoder compare mode regardless of the value of the TPnEEE bit.
  4. Set the TPnEEE and TPnMD3 to TPnMD0 bits when the TPnCTL0.TPnCE bit = 0. (The same value can be written when the TPnCE bit = 1.) The operation is not guaranteed when rewriting is performed with the TPnCE bit = 1. If rewriting was mistakenly performed, clear the TPnCE bit to 0 and then set the bits again.
  5. Be sure to clear bits 3, 4, and 7 to “0” for TMP0 to TMP6 and bits 4 and 7 to “0” for TMP7 and TMP8.

**(3) TMPm control register 2 (TPmCTL2)**

The TPmCTL2 register is an 8-bit register that controls the encoder count function operation.

The TPmCTL2 register is valid only in the encoder compare mode.

This register can be read or written in 8-bit or 1-bit units.

Reset sets this register to 00H.

**Caution** For details of each bit of the TPmCTL2 register, see 7.6.8 (5) Controlling bits of TPmCTL2 register.

(1/2)

After reset: 00H		R/W	Address: TP7CTL2 FFFFF642H, TP8CTL2 FFFFF662H					
<7>		6	5	4	3	2	1	0
TPmCTL2 (m = 7, 8)	TPmECC	0	0	TPmLDE	TPmECM1	TPmECM0	TPmUDS1	TPmUDS0
TPmECC		Encoder counter control						
0		Normal operation						
1		Holds count value of 16-bit counter when TPmCTL0.TPmCE bit = 0.						
TPmLDE		Transfer setting to 16-bit counter						
0		Disables transfer of set value of TPmCCR0 to 16-bit counter in case of underflow.						
1		Enables transfer of set value of TPmCCR0 to 16-bit counter in case of underflow.						
TPmECM1		Control of encoder clear operation 1						
0		The 16-bit counter is not cleared to 0000H when its count value matches value of CCR1 register.						
1		The 16-bit counter is cleared to 0000H when its count value matches value of CCR1 register.						
TPmECM0		Control of encoder clear operation 0						
0		The 16-bit counter is not cleared to 0000H when its count value matches value of CCR0 register.						
1		The 16-bit counter is cleared to 0000H when its count value matches value of CCR0 register.						

TPmUDS1	TPmUDS0	Up/down count selection
0	0	When valid edge of TENCm0 input is detected Counts down when TENCm1 = high level. Counts up when TENCm1 = low level.
0	1	Counts up when valid edge of TENCm0 input is detected. Counts down when valid edge of TENCm1 input is detected.
1	0	Counts down when rising edge of TENCm0 input is detected. Counts up when falling edge of TENCm0 input is detected. However, count operation is performed only when TENCm1 = low level.
1	1	Both rising and falling edges of TENCm0 and TENCm1 are detected. Count operation is automatically identified by combination of edge detection and level detection.

**Cautions 1. The TPmECC bit is valid only in the encoder compare mode. In any other mode, writing “1” to this bit is ignored.**

If the TPmCTL0.TPmCE bit is cleared to 0 while the TPmECC bit = 1, the values of the timer/counter and capture registers (TPmCCR0 and TPmCCR1), and the TPmOPT1, TPmEUF, TPmEOF, and TPmESF flags are retained.

If the TPmCE bit is set from 0 to 1 when the TPmECC bit = 1, the value of the TPmTCW register is not transferred to the 16-bit counter.

2. The TPmLDE bit is valid only when the TPmECM1 and TPmECM0 bits = 00, 01. Writing “1” to this bit is ignored when the TPmECM1 and TPmECM0 bits = 10, 11.
3. The edge detection of the TENCm0 and TENCm1 inputs specified by the TPmIOC3.TPmEIS1 and TPmIOC3.TPmEIS0 bits is invalid and fixed to both the rising and falling edges when the TPmUDS1 and TPmUDS0 bits = 10, 11.
4. Set the TPmLDE, TPmECM1, TPmECM0, TPmUDS1, and TPmUDS0 bits when the TPmCTL0.TPmCE bit = 0 (the same value can be written to these bits when the TPmCE bit = 1). If the value of these bits is changed when the TPmCE bit = 1, the operation cannot be guaranteed. If it is changed by mistake, clear the TPmCE bit and then set the correct value.
5. Be sure to clear bits 5 and 6 to “0”.

**(4) TMPn I/O control register 0 (TPnIOC0)**

The TPnIOC0 register is an 8-bit register that controls the timer output (TOPn0, TOPn1 pins).

This register can be read or written in 8-bit or 1-bit units.

Reset sets this register to 00H.

After reset: 00H R/W Address: TP0IOC0 FFFFF592H, TP1IOC0 FFFFF5A2H,  
 TP2IOC0 FFFFF5B2H, TP3IOC0 FFFFF5C2H,  
 TP4IOC0 FFFFF5D2H, TP5IOC0 FFFFF5E2H,  
 TP6IOC0 FFFFF5F2H, TP7IOC0 FFFFF643H,  
 TP8IOC0 FFFFF663H

	7	6	5	4	3	<2>	1	<0>
TPnIOC0 (n = 0 to 8)	0	0	0	0	TPnOL1	TPnOE1	TPnOL0	TPnOE0

TPnOL1	TOPn1 pin output level setting <sup>Note</sup>
0	TOPn1 pin output starts at high level
1	TOPn1 pin output starts at low level

TPnOE1	TOPn1 pin output setting
0	Timer output disabled • When TPnOL1 bit = 0: Low level is output from the TOPn1 pin • When TPnOL1 bit = 1: High level is output from the TOPn1 pin
1	Timer output enabled (a pulse is output from the TOPn1 pin).

TPnOL0	TOPn0 pin output level setting <sup>Note</sup>
0	TOPn0 pin output starts at high level
1	TOPn0 pin output starts at low level

TPnOE0	TOPn0 pin output setting
0	Timer output disabled • When TPnOL0 bit = 0: Low level is output from the TOPn0 pin • When TPnOL0 bit = 1: High level is output from the TOPn0 pin
1	Timer output enabled (a pulse is output from the TOPn0 pin).

**Note** The output level of the timer output pin (TOPna) specified by the TPnOLa bit is shown below (a = 0, 1).

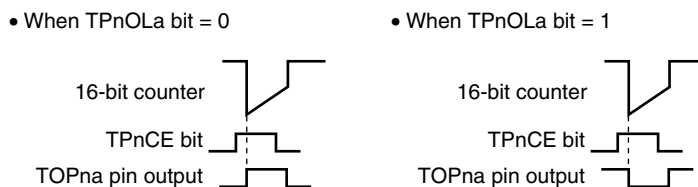

- Cautions**
1. The pin output changes if the setting of the TPnIOC0 register is rewritten when the port is set to TOPn0 and TOPn1 outputs. Therefore, note changes in the pin status by setting the port to the input mode and making the output status of the pins a high-impedance state.
  2. Rewrite the TPnOL1, TPnOE1, TPnOL0, and TPnOE0 bits when the TPnCTL0.TPnCE bit = 0. (The same value can be written when the TPnCE bit = 1.) If rewriting was mistakenly performed, clear the TPnCE bit to 0 and then set the bits again.
  3. Even if the TPnOLa bit is manipulated when the TPnCE and TPnOEa bits are 0, the TOPna pin output level varies (a = 0, 1).

**(5) TMPn I/O control register 1 (TPnIOC1)**

The TPnIOC1 register is an 8-bit register that controls the valid edge of the capture trigger input signals (TIPn0, TIPn1 pins).

This register can be read or written in 8-bit or 1-bit units.

Reset sets this register to 00H.

After reset: 00H    R/W    Address: TP0IOC1 FFFFF593H, TP1IOC1 FFFFF5A3H,  
TP2IOC1 FFFFF5B3H, TP3IOC1 FFFFF5C3H,  
TP4IOC1 FFFFF5D3H, TP5IOC1 FFFFF5E3H,  
TP6IOC1 FFFFF5F3H, TP7IOC1 FFFFF644H,  
TP8IOC1 FFFFF664H

	7	6	5	4	3	2	1	0
TPnIOC1 (n = 0 to 8)	0	0	0	0	TPnIS3	TPnIS2	TPnIS1	TPnIS0

TPnIS3	TPnIS2	Capture trigger input signal (TIPn1 pin) valid edge setting
0	0	No edge detection (capture operation invalid)
0	1	Detection of rising edge
1	0	Detection of falling edge
1	1	Detection of both edges

TPnIS1	TPnIS0	Capture trigger input signal (TIPn0 pin) valid edge setting
0	0	No edge detection (capture operation invalid)
0	1	Detection of rising edge
1	0	Detection of falling edge
1	1	Detection of both edges

- Cautions**
- 1. Rewrite the TPnIS3 to TPnIS0 bits when the TPnCTL0.TPnCE bit = 0. (The same value can be written when the TPnCE bit = 1.) If rewriting was mistakenly performed, clear the TPnCE bit to 0 and then set the bits again.**
  - 2. The TPnIS3 and TPnIS2 bits are valid only in the free-running timer mode (only when TPnOPT0.TPnCCS1 bit = 1) and the pulse width measurement mode. In all other modes, a capture operation is not possible. The TPnIS1 and TPnIS2 bits are valid only in the free-running timer mode (only when TPnOPT.TPnCCS0 bit = 1) and the pulse width measurement mode. In all other modes, a capture operation is not possible.**
  - 3. Be sure to clear bits 4 to 7 to "0".**

**(6) TMPn I/O control register 2 (TPnIOC2)**

The TPnIOC2 register is an 8-bit register that controls the valid edge of the external event count input signal (TIPn0 pin) and external trigger input signal (TIPn0 pin).

This register can be read or written in 8-bit or 1-bit units.

Reset sets this register to 00H.

After reset: 00H    R/W    Address: TP0IOC2 FFFFF594H, TP1IOC2 FFFFF5A4H,  
TP2IOC2 FFFFF5B4H, TP3IOC2 FFFFF5C4H,  
TP4IOC2 FFFFF5D4H, TP5IOC2 FFFFF5E4H,  
TP6IOC2 FFFFF5F4H, TP7IOC2 FFFFF645H,  
TP8IOC2 FFFFF665H

	7	6	5	4	3	2	1	0
TPnIOC2 (n = 0 to 8)	0	0	0	0	TPnEES1	TPnEES0	TPnETS1	TPnETS0

TPnEES1	TPnEES0	External event count input signal (TIPn0 pin) valid edge setting
0	0	No edge detection (external event count invalid)
0	1	Detection of rising edge
1	0	Detection of falling edge
1	1	Detection of both edges

TPnETS1	TPnETS0	External trigger input signal (TIPn0 pin) valid edge setting
0	0	No edge detection (external trigger invalid)
0	1	Detection of rising edge
1	0	Detection of falling edge
1	1	Detection of both edges

- Cautions**
1. Rewrite the TPnEES1, TPnEES0, TPnETS1, and TPnETS0 bits when the TPnCTL0.TPnCE bit = 0. (The same value can be written when the TPnCE bit = 1.) If rewriting was mistakenly performed, clear the TPnCE bit to 0 and then set the bits again.
  2. The TPnEES1 and TPnEES0 bits are valid only when the TPnCTL1.TPnEEE bit = 1 or when the external event count mode (TPnCTL1.TPnMD2 to TPnCTL1.TPnMD0 bits = 001) has been set.
  3. The TPnETS1 and TPnETS0 bits are valid only when the external trigger pulse output mode (TPnCTL1.TPnMD2 to TPnCTL1.TPnMD0 bits = 010) or the one-shot pulse output mode (TPnCTL1.TPnMD2 to TPnCTL1.TPnMD0 = 011) is set.
  4. Be sure to clear bits 4 to 7 to "0".

**(7) TMPm I/O control register 3 (TPmIOC3)**

The TPmIOC3 register is an 8-bit register that controls the encoder clear function operation.

The TPmIOC3 register is valid only in the encoder compare mode.

This register can be read or written in 8-bit or 1-bit units.

Reset sets this register to 00H.

(1/2)

After reset: 00H    R/W    Address: TP7IOC3 FFFFF646H, TP8IOC3 FFFFF666H									
	7	6	5	4	3	2	1	0	
TPmIOC3	TPmSCE	TPmZCL	TPmBCL	TPmACL	TPmECS1	TPmECS0	TPmEIS1	TPmEIS0	
(m = 7, 8)									
	TPmSCE	Encoder clear selection							
	0	Clears 16-bit counter on detection of edge of encoder clear signal (TECRm pin).							
	1	Clears 16-bit counter on detection of clear level condition of the TENCm0, TENCm1, and TECRm pins.							
	<ul style="list-style-type: none"> <li>Clears 16-bit counter to 0000H when valid edge of TECRm pin specified by the TPmECS1 and TPmECS0 bits is detected when the TPmSCE bit = 0.</li> <li>Clears 16-bit counter to 0000H when clear level conditions of the TPmZCL, TPmBCL, and TPmACL bits match input levels of the TECRm, TENCm1, and TENCm0 pins when TPmSCE bit = 1.</li> <li>Setting of the TPmZCL, TPmBCL, and TPmACL bits is valid and that of the TPmECS1 and TPmECS0 bits is invalid when the TPmSCE bit = 1. Encoder clear interrupt request signal (INTTPmEC) is not generated.</li> <li>Setting of the TPmZCL, TPmBCL, and TPmACL bits is invalid and setting of the TPmECS1 and TPmECS0 bits is valid when the TPmSCE bit = 0. The INTTPmEC signal is generated when valid edge specified by the TPmECS1 and TPmECS0 bits is detected.</li> <li>Be sure to set the TPmCTL2.TPmUDS1 and TPmCTL2.TPmUDS0 bits to 10 or 11 when the TPmSCE bit = 1. Operation is not guaranteed if the TPmUDS1 and TPmUDS0 bits = 00 or 01 and the TPmSCE bit = 1.</li> </ul>								
	TPmZCL	Clear level selection of encoder clear signal (TECRm pin)							
	0	Clears low level of the TECRm pin.							
	1	Clears high level of the TECRm pin.							
	Setting of the TPmZCL bit is valid only when the TPmSCE bit = 1.								
	TPmBCL	Clear level selection of encoder input signal (TENCm1 pin)							
	0	Clears low level of the TENCm1 pin.							
	1	Clears high level of the TENCm1 pin.							
	Setting of the TPmBCL bit is valid only when the TPmSCE bit = 1.								
	TPmACL	Clear level selection of encoder input signal (TENCm0 pin)							
	0	Clears low level of the TENCm0 pin.							
	1	Clears high level of the TENCm0 pin.							
	Setting of the TPmACL bit is valid only when the TPmSCE bit = 1.								



TPmECS1	TPmECS0	Valid edge setting of encoder clear signal (TECRm pin)
0	0	Detects no edge (clearing encoder is invalid).
0	1	Detects rising edge.
1	0	Detects falling edge.
1	1	Detects both edges.

TPmEIS1	TPmEIS0	Valid edge setting of encoder input signals (TENCm0, TENCm1 pins)
0	0	Detects no edge (inputting encoder is invalid).
0	1	Detects rising edge.
1	0	Detects falling edge.
1	1	Detects both edges.

- Cautions**
1. Rewrite the TPmSCE, TPmZCL, TPmBCL, TPmACL, TPmECS1, TPmECS0, TPmEIS1, and TPmEIS0 bits when the TPmCTL0.TPmCE bit = 0. (The same value can be written to these bits when the TPmCE bit = 1.) If rewriting was mistakenly performed, clear the TPmCE bit to 0 and then set these bits again.
  2. The TPmECS1 and TPmECS0 bits are valid only when the TPmSCE bit = 0 and the encoder compare mode is set.
  3. The TPmEIS1 and TPmEIS0 bits are valid only when the TPmCTL2.TPmUDS1 and TPmCTL2.TPmUDS0 bits = 00 or 01.

**(8) TMPn option register 0 (TPnOPT0)**

The TPnOPT0 register is an 8-bit register used to set the capture/compare operation and detect an overflow.

This register can be read or written in 8-bit or 1-bit units.

Reset sets this register to 00H.

After reset: 00H R/W Address: TP0OPT0 FFFFF595H, TP1OPT0 FFFFF5A5H,  
 TP2OPT0 FFFFF5B5H, TP3OPT0 FFFFF5C5H,  
 TP4OPT0 FFFFF5D5H, TP5OPT0 FFFFF5E5H,  
 TP6OPT0 FFFFF5F5H, TP7OPT0 FFFFF647H,  
 TP8OPT0 FFFFF667H

	7	6	5	4	3	2	1	<0>
TPnOPT0 (n = 0 to 8)	0	0	TPnCCS1	TPnCCS0	0	0	0	TPnOVF

TPnCCS1	TPnCCR1 register capture/compare selection
0	Compare register selected
1	Capture register selected (cleared by setting TPnCTL0.TPnCE bit = 0)
The TPnCCS1 bit setting is valid only in the free-running timer mode.	

TPnCCS0	TPnCCR0 register capture/compare selection
0	Compare register selected
1	Capture register selected (cleared by setting TPnCTL0.TPnCE bit = 0)
The TPnCCS0 bit setting is valid only in the free-running timer mode.	

TPnOVF	TMPn overflow detection flag
Set (1)	Overflow occurred
Reset (0)	TPnOVF bit 0 written or TPnCTL0.TPnCE bit = 0
<ul style="list-style-type: none"> <li>The TPnOVF bit is set when the 16-bit counter count value overflows from FFFFH to 0000H in the free-running timer mode or the pulse width measurement mode.</li> <li>An overflow interrupt request signal (INTTPnOV) is generated at the same time that the TPnOVF bit is set to 1. The INTTPnOV signal is not generated in modes other than the free-running timer mode and the pulse width measurement mode.</li> <li>The TPnOVF bit is not cleared to 0 even when the TPnOVF bit or the TPnOPT0 register are read when the TPnOVF bit = 1.</li> <li>Before clearing the TPnOVF bit to 0 after the INTTPnOV signal has been generated, be sure to confirm (read) that the TPnOVF bit is set to 1.</li> <li>The TPnOVF bit can be both read and written, but the TPnOVF bit cannot be set to 1 by software. Writing 1 has no influence on the operation of TMPn.</li> </ul>	

- Cautions**
1. Rewrite the TPnCCS1 and TPnCCS0 bits when the TPnCE bit = 0. (The same value can be written when the TPnCE bit = 1.) If rewriting was mistakenly performed, clear the TPnCE bit to 0 and then set the bits again.
  2. Be sure to clear bits 1 to 3, 6, and 7 to “0”.

**(9) TMPm option register 1 (TPmOPT1)**

The TPmOPT1 register is an 8-bit register that detects the overflow, underflow, and count-up/down operation of the encoder count function.

The TPmOPT1 register is valid only in the encoder compare mode.

This register can be read or written in 8-bit or 1-bit units.

Reset sets this register to 00H.

This register can be rewritten even when the TPmCTL0.TPmCE bit = 1.

(1/2)

After reset: 00H		R/W	Address: TP7OPT1 FFFFFFF648H, TP8OPT1 FFFFFFF668H					
	7	6	5	4	3	<2>	<1>	<0>
TPmOPT1	0	0	0	0	0	TPmEUF	TPmEOF	TPmESF
(m = 7, 8)								
TPmEUF	TMPm underflow detection flag							
Set (1)	Underflow occurs.							
Reset (0)	Cleared by writing to TPmEUF bit or when TPmCTL0.TPmCE bit = 0							
	<ul style="list-style-type: none"> <li>• The TPmEUF bit is set to 1 when 16-bit counter underflows from 0000H to FFFFH in encoder compare mode.</li> <li>• When the TPmCTL2.TPmLDE bit = 1, TPmEUF bit is set to 1 when value of 16-bit counter is changed from 0000H to set value of the TPmCCR0 register.</li> <li>• Overflow interrupt request signal (INTTPmOV) is generated as soon as the TPmEUF bit is set to 1.</li> <li>• The TPmEUF bit is not cleared to 0 even if the TPmEUF bit or TPmOPT1 register is read when the TPmEUF bit = 1.</li> <li>• Status of the TPmEUF bit is retained even if the TPmCTL0.TPmCE bit is cleared to 0 when the TPmCTL2.TPmECC bit = 1.</li> <li>• Before clearing the TPmEUF bit to 0 after the INTTPmOV signal is generated, be sure to confirm (read) that the TPmEUF bit is set to 1.</li> <li>• The TPmEUF bit can be read or written, but it cannot be set to 1 by software. Setting this bit to 1 does not affect operation of TMPm.</li> </ul>							

TPmEOF	Overflow detection flag for TMPm encoder function
Set (1)	Overflow occurs.
Reset (0)	Cleared by writing 0 to the TPmEOF bit or when the TPmCTL0.TPmCE bit = 0
<ul style="list-style-type: none"> <li>• The TPmEOF bit is set to 1 when 16-bit counter overflows from FFFFH to 0000H in encoder compare mode.</li> <li>• As soon as the TPmEOF bit has been set to 1, an overflow interrupt request signal (INTTPmOV) is generated. At this time, the TPmOPT0.TPmOVF bit is not set to 1.</li> <li>• The TPmEOF bit is not cleared to 0 even if the TPmEOF bit or TPmOPT1 register is read when the TPmEOF bit = 1.</li> <li>• Status of the TPmEOF bit is retained even if the TPmCTL0.TPmCE bit is cleared to 0 when the TPmCTL2.TPmECC bit = 1.</li> <li>• Before clearing the TPmEOF bit to 0 after the INTTPmOV signal is generated, be sure to confirm (read) that the TPmEOF bit is set to 1.</li> <li>• The TPmEOF bit can be read or written, but it cannot be set to 1 by software. Writing 1 to this bit does not affect operation of TMPm.</li> </ul>	

TPmESF	TMPm count-up/-down operation status detection flag
0	TMPm is counting up.
1	TMPm is counting down.
<ul style="list-style-type: none"> <li>• This bit is cleared to 0 if the TPmCTL0.TPmCE bit = 0 when the TPmCTL2.TPmECC bit = 0.</li> <li>• Status of the TPmESF bit is retained even if the TPmCE bit = 0 when the TPmECC bit = 1.</li> </ul>	

**Caution** Be sure to clear bits 3 to 7 to “0”.

**(10) TMPn capture/compare register 0 (TPnCCR0)**

The TPnCCR0 register is a 16-bit register that can be used as a capture register or a compare register depending on the mode.

This register can be used as a capture register or a compare register only in the free-running timer mode, depending on the setting of the TPnOPT0.TPnCCS0 bit. In the pulse width measurement mode, the TPnCCR0 register can be used only as a capture register. In any other mode, this register can be used only as a compare register.

The TPnCCR0 register can be read or written during operation.

This register can be read or written in 16-bit units.

Reset sets this register to 0000H.

**Caution** Accessing the TPnCCR0 register is prohibited in the following statuses. For details, refer to 3.4.9 (2) Accessing specific on-chip peripheral I/O registers.

- When the CPU operates with the subclock and the main clock oscillation is stopped
- When the CPU operates with the internal oscillation clock

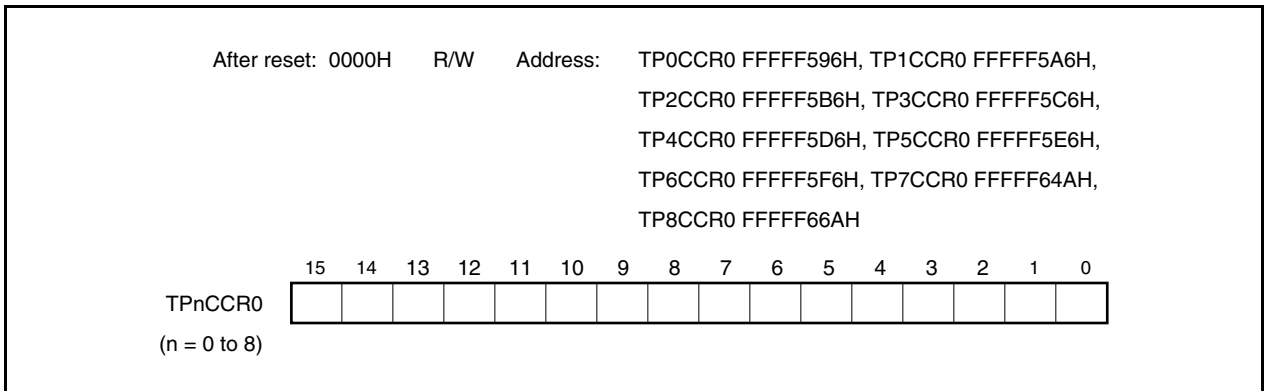

**(a) Function as compare register**

The TPnCCR0 register can be rewritten even when the TPnCTL0.TPnCE bit = 1.

The set value of the TPnCCR0 register is transferred to the CCR0 buffer register. When the value of the 16-bit counter matches the value of the CCR0 buffer register, a compare match interrupt request signal (INTTPnCC0) is generated. If TOPn0 pin output is enabled at this time, the output of the TOPn0 pin is inverted.

When the TPnCCR0 register is used as a cycle register in the interval timer mode, external event count mode, external trigger pulse output mode, one-shot pulse output mode, PWM output mode, or encoder compare mode, the value of the 16-bit counter is cleared (0000H) if its count value matches the value of the CCR0 buffer register.

The compare register is not cleared when the TPnCTL0.TPnCE bit = 0.

**(b) Function as capture register**

In the free-running timer mode (when the TPnCCR0 register is used as a capture register), the count value of the 16-bit counter is stored in the TPnCCR0 register if the valid edge of the capture trigger input pin (TIPn0 pin) is detected. In the pulse-width measurement mode, the count value of the 16-bit counter is stored in the TPnCCR0 register and the 16-bit counter is cleared (0000H) if the valid edge of the capture trigger input pin (TIPn0) is detected.

Even if the capture operation and reading the TPnCCR0 register conflict, the correct value of the TPnCCR0 register can be read.

The capture register is cleared when the TPnCTL0.TPnCE bit = 0.

**Remark** n = 0 to 8

The following table shows the functions of the capture/compare register in each mode, and how to write data to the compare register.

**Table 7-3. Function of Capture/Compare Register in Each Mode and How to Write Compare Register**

Operation Mode	Capture/Compare Register	How to Write Compare Register
Interval timer	Compare register	Anytime write
External event counter	Compare register	Anytime write
External trigger pulse output	Compare register	Batch write <sup>Note</sup>
One-shot pulse output	Compare register	Anytime write
PWM output	Compare register	Batch write <sup>Note</sup>
Free-running timer	Capture/compare register	Anytime write
Pulse width measurement	Capture register	None
Encoder compare	Compare register	Anytime write

**Note** Triggered by writing to the TPnCCR1 register

**Remark** For details of anytime write and batch write, see 7.6 (3) **Anytime write and batch write**.

**(11) TMPn capture/compare register 1 (TPnCCR1)**

The TPnCCR1 register is a 16-bit register that can be used as a capture register or a compare register depending on the mode.

This register can be used as a capture register or a compare register only in the free-running timer mode, depending on the setting of the TPnOPT0.TPnCCS1 bit. In the pulse width measurement mode, the TPnCCR1 register can be used only as a capture register. In any other mode, this register can be used only as a compare register.

The TPnCCR1 register can be read or written during operation.

This register can be read or written in 16-bit units.

Reset sets this register to 0000H.

**Caution** Accessing the TPnCCR1 register is prohibited in the following statuses. For details, refer to 3.4.9 (2) Accessing specific on-chip peripheral I/O registers.

- When the CPU operates with the subclock and the main clock oscillation is stopped
- When the CPU operates with the internal oscillation clock

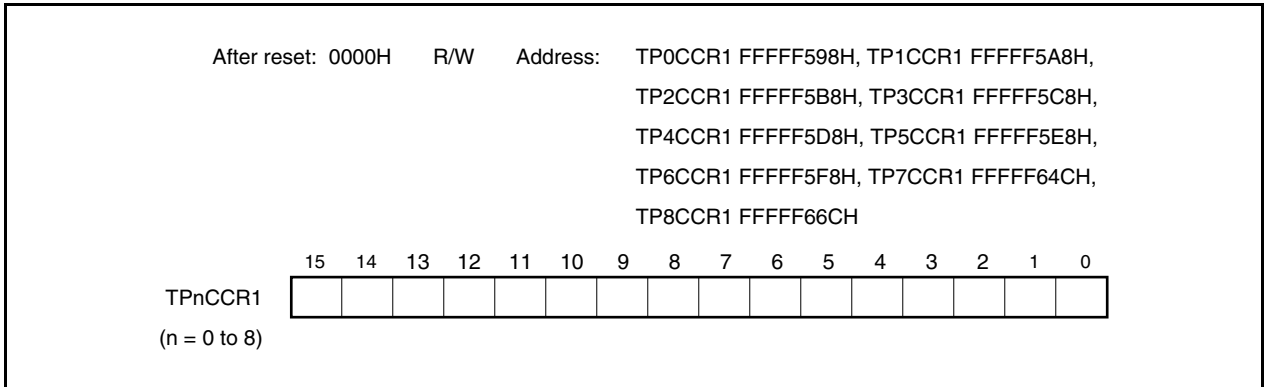

**(a) Function as compare register**

The TPnCCR1 register can be rewritten even when the TPnCTL0.TPnCE bit = 1.

The set value of the TPnCCR1 register is transferred to the CCR1 buffer register. When the value of the 16-bit counter matches the value of the CCR1 buffer register, a compare match interrupt request signal (INTTPnCC1) is generated. If TOPn1 pin output is enabled at this time, the output of the TOPn1 pin is inverted.

The compare register is not cleared when the TPnCTL0.TPnCE bit = 0.

**(b) Function as capture register**

In the free-running timer mode (when the TPnCCR1 register is used as a capture register), the count value of the 16-bit counter is stored in the TPnCCR1 register if the valid edge of the capture trigger input pin (TIPn1 pin) is detected. In the pulse-width measurement mode, the count value of the 16-bit counter is stored in the TPnCCR1 register and the 16-bit counter is cleared (0000H) if the valid edge of the capture trigger input pin (TIPn1) is detected.

Even if the capture operation and reading the TPnCCR1 register conflict, the correct value of the TPnCCR1 register can be read.

The capture register is cleared when the TPnCTL0.TPnCE bit = 0.

**Remark** n = 0 to 8

The following table shows the functions of the capture/compare register in each mode, and how to write data to the compare register.

**Table 7-4. Function of Capture/Compare Register in Each Mode and How to Write Compare Register**

Operation Mode	Capture/Compare Register	How to Write Compare Register
Interval timer	Compare register	Anytime write
External event counter	Compare register	Anytime write
External trigger pulse output	Compare register	Batch write <sup>Note</sup>
One-shot pulse output	Compare register	Anytime write
PWM output	Compare register	Batch write <sup>Note</sup>
Free-running timer	Capture/compare register	Anytime write
Pulse width measurement	Capture register	None
Encoder compare	Compare register	Anytime write

**Note** Triggered by writing to the TPnCCR1 register

**Remark** For anytime write and batch write, see 7.6 (3) **Anytime write and batch write**.



**(12) TMPm counter write register (TPmTCW)**

The TPmTCW register is used to set the initial value of the 16-bit counter.

The TPmTCW register is valid only in the encoder compare mode.

This register can be read or written in 16-bit units.

Rewrite the TPmTCW register when the TPmCTL0.TPmCE bit = 0.

The value of the TPmTCW register is transferred to the 16-bit counter when the TPmCE bit is set (1).

Reset sets this register to 0000H.

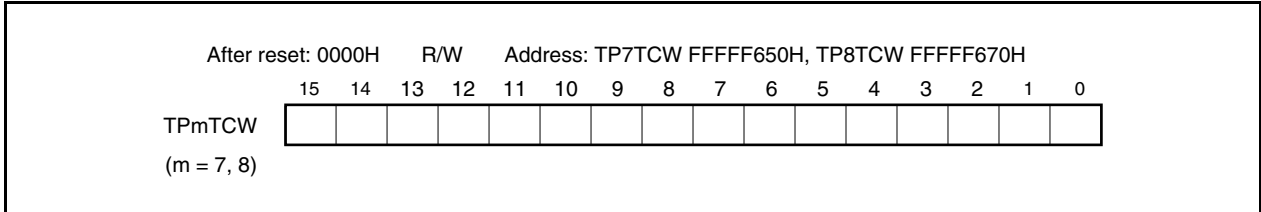

**(13) TMPn counter read buffer register (TPnCNT)**

The TPnCNT register is a read buffer register that can read the count value of the 16-bit counter.

If this register is read when the TPnCTL0.TPnCE bit = 1, the count value of the 16-bit timer can be read.

This register is read-only, in 16-bit units.

For TMP0 to TMP6, the value of the TPkCNT register is cleared to 0000H when the TPkCE bit = 0. If the TPkCNT register is read at this time, the value of the 16-bit counter (FFFFH) is not read, but 0000H is read.

The value of the TPkCNT register is cleared to 0000H after reset, because the TPkCE bit is cleared to 0.

For TMP7 and TMP8, the value of the TPmCNT register is set to 0000H when the TPmCTL2.TPmECC and TPmCE bits = 0. If the TPmCNT register is read at this time, the value of the 16-bit counter (FFFFH) is not read, but 0000H is read. The TPmCNT register is not set to 0000H but the previous value is read when the TPmECC bit = 1 and TPmCE bit = 0.

The TPmECC and TPmCE bits are set to 0 after reset, and the value of the TPmCNT register is set to 0000H.

**Caution** Accessing the TPnCNT register is prohibited in the following statuses. For details, refer to 3.4.9 (2) Accessing specific on-chip peripheral I/O registers.

- When the CPU operates with the subclock and the main clock oscillation is stopped
- When the CPU operates with the internal oscillation clock

**Remark** n = 0 to 8  
k = 0 to 6  
m = 7, 8

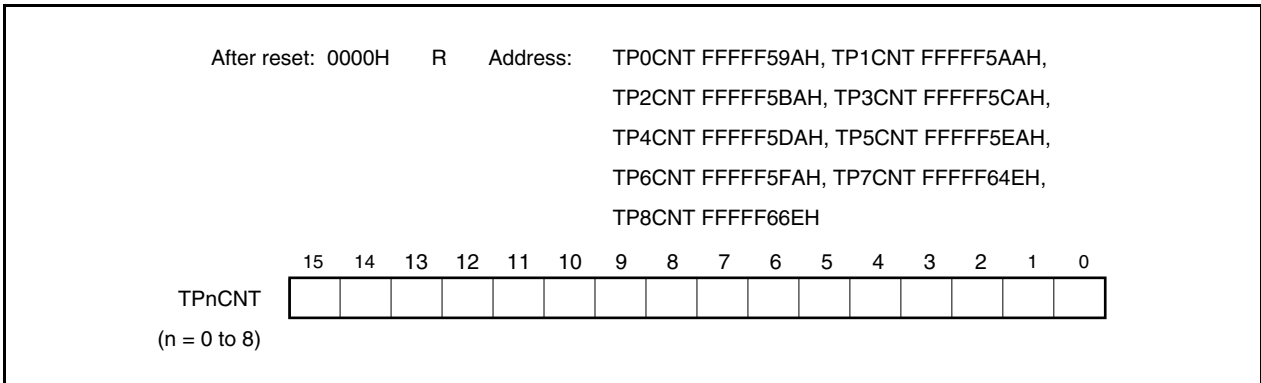

**(14) TMPm noise elimination control register (ENaNFC)**

Digital noise elimination can be selected for the TECRm, TENCm0, and TENCm1 pins. The noise elimination settings are performed using the ENaNFC register.

When digital noise elimination is selected, the sampling clock for digital sampling can be selected from among  $f_{XP}$ ,  $f_{XP}/4$ ,  $f_{XP}/8$ ,  $f_{XP}/16$ ,  $f_{XP}/32$ , and  $f_{XP}/64$ . The number of times sampling is performed can be selected from either two or three times.

This register can be read or written in 8-bit units.

Reset sets this register to 00H.

**Caution** After the sampling clock has been changed, it takes 3 sampling clocks to initialize the digital noise eliminator when the number of times sampling is performed is three, and 2 sampling clocks when it is two. Therefore, if a TECRm, TENCm0, or TENCm1 valid edge is input within these 2 or 3 sampling clocks after the sampling clock has been changed, an encoder input may occur. Therefore, when using the TMPm encoder count function, enable TMPm after 2 or 3 sampling clocks have elapsed.

After reset: 00H R/W Address: EN0NFC FFFFF31CH, EN1NFC FFFFF31EH

	7	6	5	4	3	2	1	0
ENaNFC	ENaNFEN	ENaNFSTS	0	0	0	ENaNFC2	ENaNFC1	ENaNFC0
{ a = 0 when m = 7 a = 1 when m = 8 }	Settings of TECRm, TENCm0, TENCm1 pins digital noise elimination							
	0	Digital noise elimination is not executed.						
	1	Digital noise elimination is executed.						
	Selection of number of times of sampling							
	0	Three times						
	1	Two times						
	ENaNFC2	ENaNFC1	ENaNFC0	Digital sampling clock				
	0	0	0	$f_{XP}$				
	0	0	1	$f_{XP}/4$				
	0	1	0	$f_{XP}/8$				
	0	1	1	$f_{XP}/16$				
	1	0	0	$f_{XP}/32$				
	1	0	1	$f_{XP}/64$				
	Other than above			Setting prohibited				

- Remarks**
1. When sampling is performed three times, the reliably eliminated noise width is 2 sampling clocks. When sampling is performed two times, the width is 1 sampling clock.
  2. In the case of noise with a width smaller than 1 or 2 sampling clocks, encoder count operation is executed if noise synchronized with the sampling clock is input.

Figure 7-3 shows a timing example of noise elimination by digital filtering by the encoder count function input pins (TECRm, TENCm0, and TENCm1).

**Figure 7-3. Digital Noise Elimination Timing Example (Sampling: 3 Times (ENaNFSTS Bit = 0))**

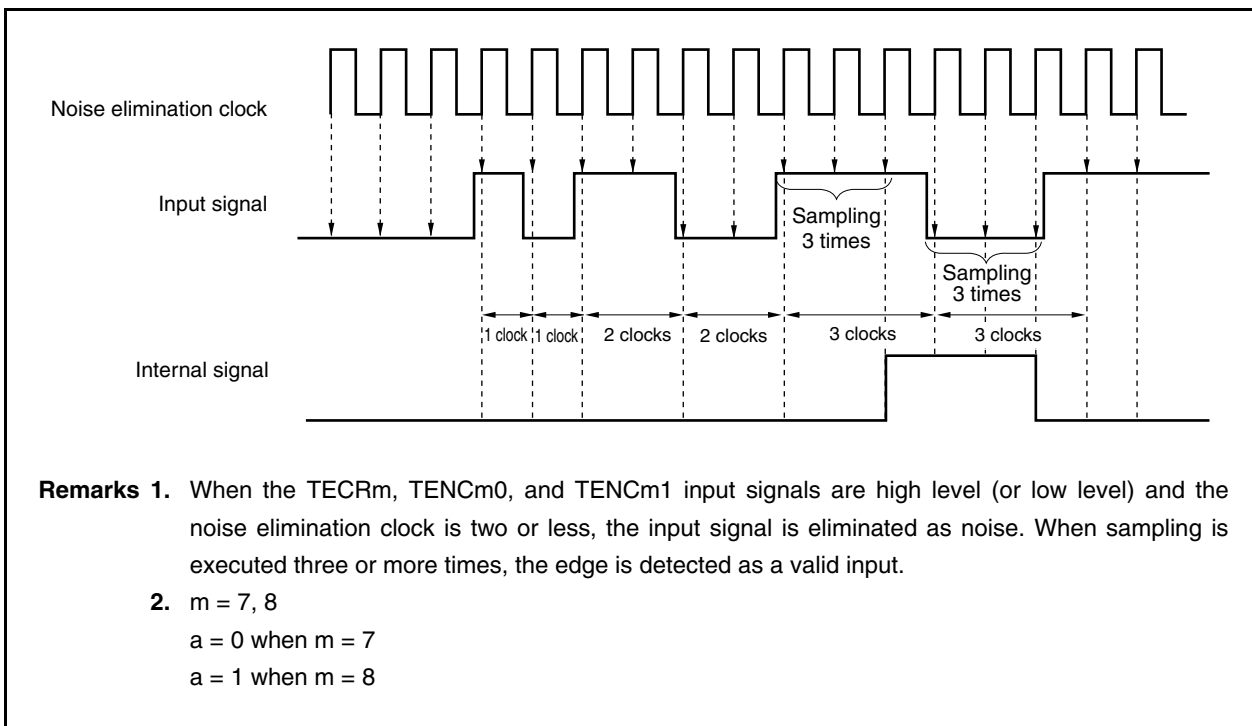

## 7.5 Timer Output Operations

The following table shows the operations and output levels of the TOPn0 and TOPn1 pins.

**Table 7-5. Timer Output Control in Each Mode**

Operation Mode	TOPn1 Pin	TOPn0 Pin
Interval timer mode	Square wave output	
External event count mode	None	
External trigger pulse output mode	External trigger pulse output	Square wave output
One-shot pulse output mode	One-shot pulse output	
PWM output mode	PWM output	
Free-running timer mode	Square wave output (only when compare function is used)	
Pulse width measurement mode	None	
Encoder compare mode		

**Remark** n = 0 to 8

**Table 7-6. Truth Table of TOPn0 and TOPn1 Pins Under Control of Timer Output Control Bits**

TPnIOC0.TPnOLa Bit	TPnIOC0.TPnOEa Bit	TPnCTL0.TPnCE Bit	Level of TOPna Pin
0	0	×	Low-level output
	1	0	Low-level output
		1	Low level immediately before counting, high level after counting is started
1	0	×	High-level output
	1	0	High-level output
		1	High level immediately before counting, low level after counting is started

**Remark** n = 0 to 8  
m = 0, 1

## 7.6 Operation

TMP0 to TMP6 can perform the following operations.

Operation	TPkCTL1.TPkEST Bit (Software Trigger Bit)	TIPk0 Pin (External Trigger Input)	Capture/Compare Register Setting	Compare Register Write
Interval timer mode	Invalid	Invalid	Compare only	Anytime write
External event count mode <sup>Note 1</sup>	Invalid	Invalid	Compare only	Anytime write
External trigger pulse output mode <sup>Note 2</sup>	Valid	Valid	Compare only	Batch write
One-shot pulse output mode <sup>Note 2</sup>	Valid	Valid	Compare only	Anytime write
PWM output mode	Invalid	Invalid	Compare only	Batch write
Free-running timer mode	Invalid	Invalid	Switching enabled	Anytime write
Pulse width measurement mode <sup>Note 2</sup>	Invalid	Invalid	Capture only	Not applicable

- Notes 1.** To use the external event count mode, specify that the valid edge of the TIPk0 pin capture trigger input is not detected (by clearing the TPkIOC1.TPkIS1 and TPkIOC1.TPkIS0 bits to “00”).
- 2.** When using the external trigger pulse output mode, one-shot pulse output mode, and pulse width measurement mode, select the internal clock as the count clock (by clearing the TPkCTL1.TPkEEE bit to 0).

**Remark** k = 0 to 6

TMP7 and TMP8 can perform the following operations.

Operation	TPmCTL1.TPmEST Bit (Software Trigger Bit)	TIPm0 Pin (External Trigger Input)	Capture/Compare Register Setting	Compare Register Write
Interval timer mode	Invalid	Invalid	Compare only	Anytime write
External event count mode <sup>Note 1</sup>	Invalid	Invalid	Compare only	Anytime write
External trigger pulse output mode <sup>Note 2</sup>	Valid	Valid	Compare only	Batch write
One-shot pulse output mode <sup>Note 2</sup>	Valid	Valid	Compare only	Anytime write
PWM output mode	Invalid	Invalid	Compare only	Batch write
Free-running timer mode	Invalid	Invalid	Switching enabled	Anytime write
Pulse width measurement mode <sup>Note 2</sup>	Invalid	Invalid	Capture only	Not applicable
Encoder compare mode	Invalid	Invalid	Compare only	Anytime write

- Notes 1.** To use the external event count mode, specify that the valid edge of the TIPm0 pin capture trigger input is not detected (by clearing the TPmIOC1.TPmIS1 and TPmIOC1.TPmIS0 bits to “00”).
- 2.** When using the external trigger pulse output mode, one-shot pulse output mode, and pulse width measurement mode, select the internal clock as the count clock (by clearing the TPmCTL1.TPmEEE bit to 0).

**Remark** m = 7, 8

**(1) Counter basic operation for TMP0 to TMP6**

This section explains the basic operation of the 16-bit counter. For details, refer to the description of the operation in each mode.

**Remark**  $k = 0$  to 6

**(a) Count start operation**

- **In external event count mode**

The 16-bit counter is set to 0000H at the timing when the TPkCE bit changes from 0 to 1.

After that, the counter counts up from 0001H to 0002H, 0003H, and so on, each time a valid edge of an external event count input (TIPk0) is detected.

- **In other modes**

The 16-bit counter of TMPn starts counting from the default value FFFFH.

It counts up from FFFFH to 0000H, 0001H, 0002H, 0003H, and so on.

**(b) Clear operation**

The 16-bit counter is cleared to 0000H when its value matches the value of the compare register and is cleared, and when its value is captured and cleared. The counting operation from FFFFH to 0000H that takes place immediately after the counter has started counting or when the counter overflows is not a clearing operation. Therefore, the INTTPkCC0 and INTTPkCC1 interrupt signals are not generated.

**(c) Overflow operation**

The 16-bit counter overflows when the counter counts up from FFFFH to 0000H in the free-running timer mode or pulse width measurement mode. If the counter overflows, the TPkOPT0.TPkOVF bit is set to 1 and an interrupt request signal (INTTPkOV) is generated. Note that the INTTPkOV signal is not generated under the following conditions.

- Immediately after a counting operation has been started
- If the counter value matches the compare value FFFFH and is cleared
- When FFFFH is captured and cleared in the pulse width measurement mode and the counter counts up from FFFFH to 0000H

**Caution** After the overflow interrupt request signal (INTTPkOV) has been generated, be sure to check that the overflow flag (TPkOVF bit) is set to 1.

**(d) Counter read operation during counting operation**

The value of the 16-bit counter of TMPk can be read by using the TPkCNT register during the count operation. When the TPkCTL0.TPkCE bit = 1, the value of the 16-bit counter can be read by reading the TPkCNT register. When the TPkCTL0.TPkCE bit = 0, the 16-bit counter is FFFFH and the TPkCNT register is 0000H.

**(e) Interrupt operation**

TMPk generates the following three types of interrupt request signals.

- INTTPkCC0 interrupt: This signal functions as a match interrupt request signal of the CCR0 buffer register and as a capture interrupt request signal to the TPkCCR0 register.
- INTTPkCC1 interrupt: This signal functions as a match interrupt request signal of the CCR1 buffer register and as a capture interrupt request signal to the TPkCCR1 register.
- INTTPkOV interrupt: This signal functions as an overflow interrupt request signal.

**(2) Counter basic operation for TMP7 and TMP8**

This section explains the basic operation of the 16-bit counter. For details, refer to the description of the operation in each mode.

**Remark** m = 7, 8

**(a) Counter start operation**

- **Encoder compare mode**

The count operation is controlled by TENCm0 and TENCm1 phases.

When the 16-bit counter initial setting is performed by transferring the set value of the TPmTCW register to the 16-bit counter and the count operation is started. (When the TPmCTL2.TPmECC bit = 0, the TPmTCW register set value is transferred to the 16-bit counter at the timing when the TPmCTL0.TPmCE bit changes from 0 to 1.)

- **External event counter mode**

The 16-bit counter is set to 0000H at the timing when the TPkCE bit changes from 0 to 1.

After that, the counter counts up from 0001H to 0002H, 0003H, and so on, each time a valid edge of an external event counter input (TIPk0) is detected.

- **Mode other than above**

The 16-bit counter starts counting from the initial value FFFFH.

It counts up from FFFFH to 0000H, 0001H, 0002H, 0003H, and so on.

**(b) Clear operation**

The 16-bit counter is cleared to 0000H when its value matches the value of the compare register and cleared, when the value of the 16-bit counter is captured and cleared, when the edge of the encoder clear signal is detected and cleared, and when the clear level condition of the TENCm0, TENCm1, and TECRm pins is detected and cleared. The count operation from FFFFH to 0000H that takes place immediately after the counter has started counting or when the counter overflows is not a clearing operation. Therefore, the INTTPkCC0 and INTTPkCC1 interrupt signals are not generated.

**(c) Overflow operation**

The 16-bit counter overflows when the counter counts up from FFFFH to 0000H in the free-running mode, pulse width measurement mode, and encoder compare mode. If the counter overflows, the TPmOPT0.TPmOVF bit is set to 1 and an interrupt request signal (INTTPmOV) is generated in the free-running mode and pulse width measurement mode.

If the counter overflows, the TPmOPT1.TPmEOF bit is set to 1 and an interrupt request signal (INTTPmOV) is generated in the encoder compare mode.

Note that the INTTPmOV signal is not generated under the following conditions.

- Immediately after a count operation has been started
- If the counter value matches the compare value FFFFH and is cleared
- When FFFFH is captured and cleared to 0000H in the pulse width measurement mode

**Caution** After the overflow interrupt request signal (INTTPmOV) has been generated, be sure to check that the overflow flag (TPmOVF, TPmEOF bits) is set to 1.

**(d) Count value holding operation**

The value of the 16-bit counter is held by the TPmCTL2.TPmECC bit in the encoder compare mode. The value of the 16-bit counter is reset to FFFFH when the TPmECC bit = 0 and TPmCTL0.TPmCE bit = 0. When the TPmCE bit is set to 1 next time, the set value of the TPmTCW register is transferred to the 16-bit counter and the counter continues its count operation.

If the TPmECC bit = 1 and TPmCE bit = 0, the value of the 16-bit counter is held. When the TPmCE bit is set to 1 next time, the counter resumes the count operation from the held value.

**(e) Counter read operation during count operation**

The value of the 16-bit counter of TMPm can be read by using the TPmCNT register during the count operation. When the TPmCTL0.TPmCE bit = 1, the value of the 16-bit counter can be read by reading the TPmCNT register. If the TPmCNT register is read when the TPmCTL2.TPmECC bit = 0 and TPmCE bit = 0, however, it is 0000H. The held value of the TPmCNT register is read if the register is read when the TPmECC bit = 1 and TPmCE bit = 0.

**(f) Underflow operation**

The 16-bit counter underflow occurs at the timing when the 16-bit counter value changes from 0000H to FFFFH in the encoder compare mode. When underflow occurs, the TPmOPT1.TPmEUF bit is set to 1 and an interrupt request signal (INTTPmOV) is generated.

**(g) Interrupt operation**

TMPm generates the following four types of interrupt request signals.

- INTTPmCC0 interrupt: This signal functions as a match interrupt request signal of the CCR0 buffer register and as a capture interrupt request signal to the TPmCCR0 register.
- INTTPmCC1 interrupt: This signal functions as a match interrupt request signal of the CCR1 buffer register and as a capture interrupt request signal to the TPmCCR1 register.
- INTTPmOV interrupt: This signal functions as an overflow interrupt request signal.
- INTTPmEC interrupt: This signal functions as a valid edge detection interrupt request signal of the encoder clear input (TECRm pin).



**(3) Anytime write and batch write**

The TPnCCR0 and TPnCCR1 registers in TMPn can be rewritten during timer operation (TPnCTL0.TPnCE bit = 1), but the write method (anytime write, batch write) of the CCR0 and CCR1 buffer registers differs depending on the mode.

**(a) Anytime write**

In this mode, data is transferred at any time from the TPnCCR0 and TPnCCR1 registers to the CCR0 and CCR1 buffer registers during timer operation. (n = 0 to 8).

**Figure 7-4. Flowchart of Basic Operation for Anytime Write**

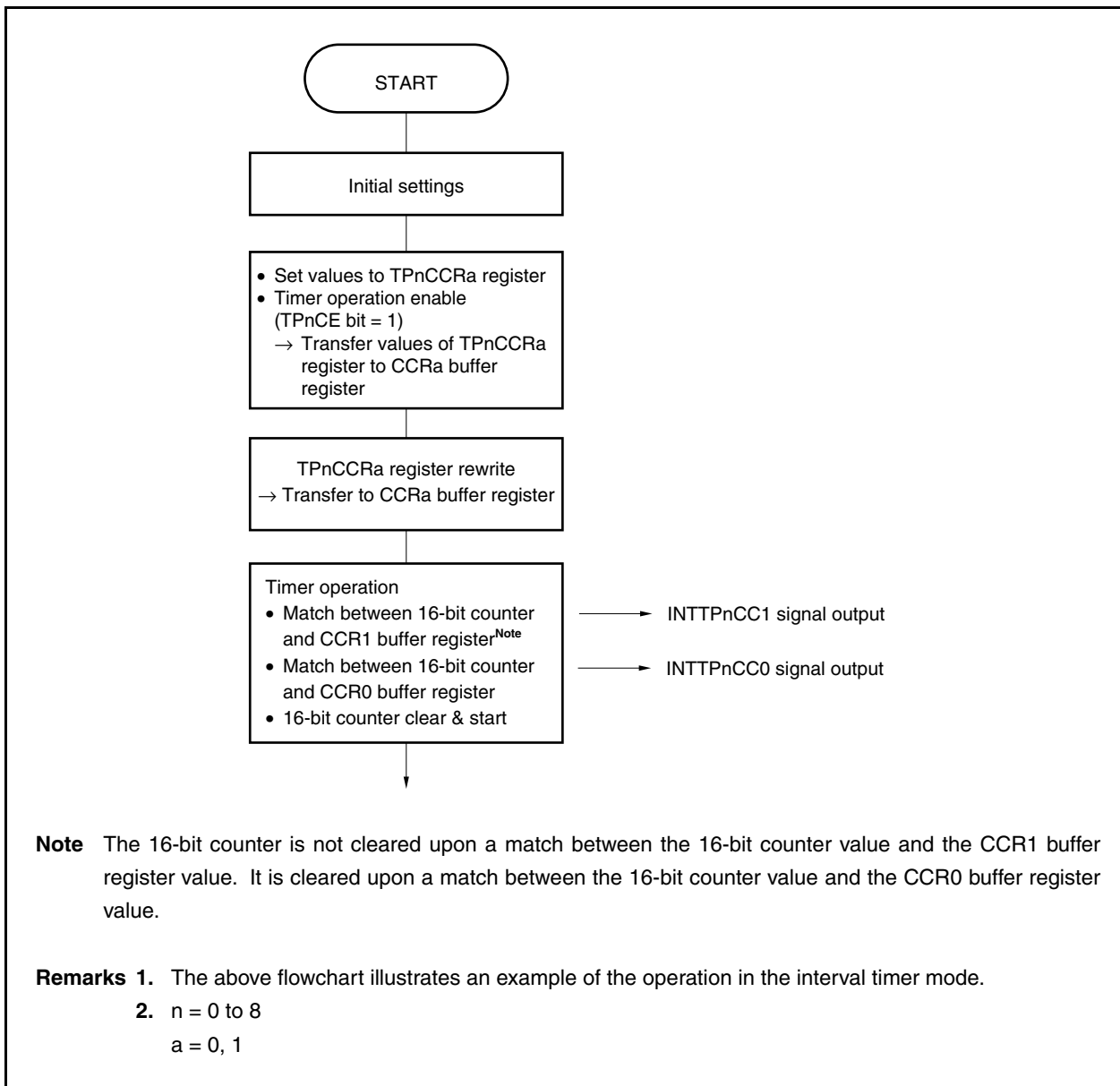
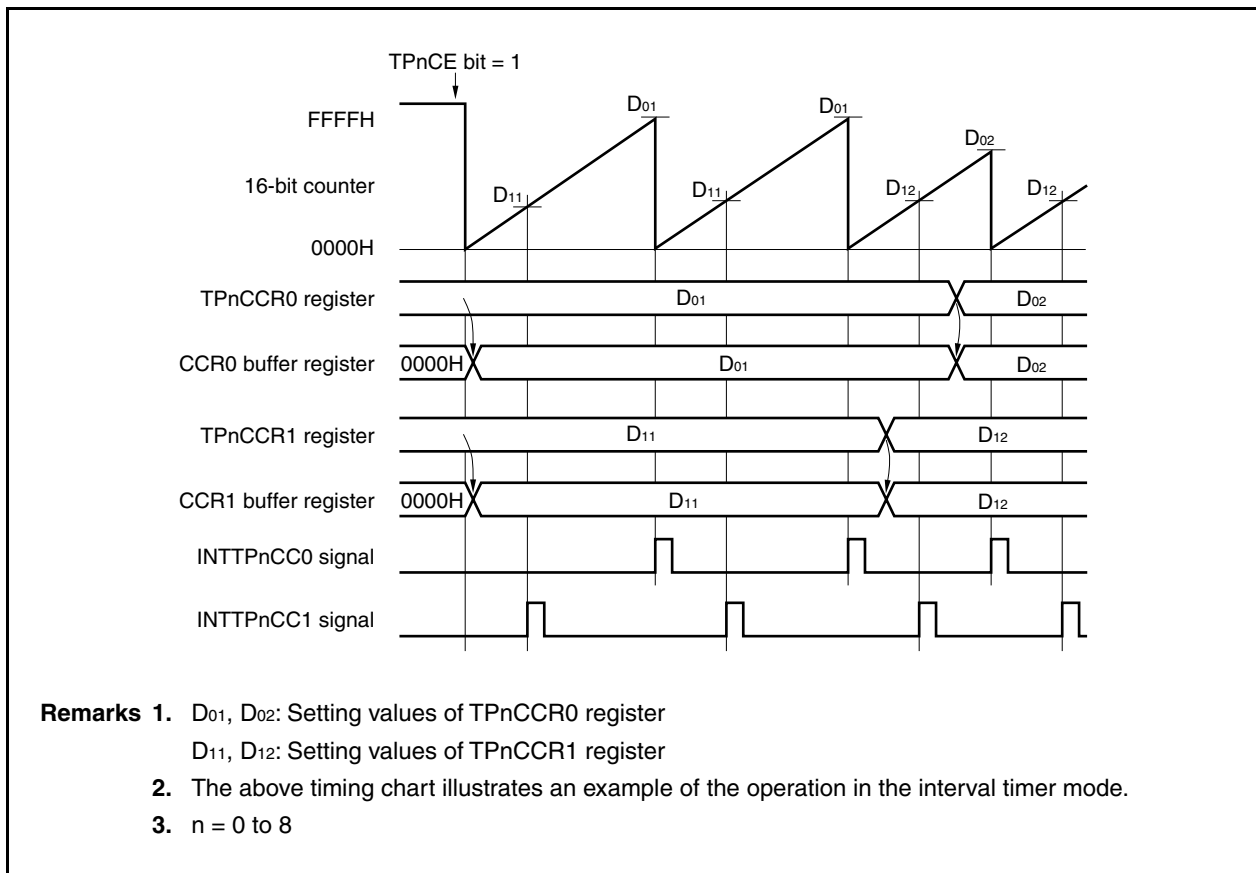

Figure 7-5. Timing of Anytime Write



**(b) Batch write**

In this mode, data is transferred all at once from the TPnCCR0 and TPnCCR1 registers to the CCR0 and CCR1 buffer registers during timer operation. This data is transferred upon a match between the value of the CCR0 buffer register and the value of the 16-bit counter. Transfer is enabled by writing to the TPnCCR1 register.

Whether to enable or disable the next transfer timing is controlled by writing or not writing to the TPnCCR1 register.

In order for the setting value when the TPnCCR0 and TPnCCR1 registers are rewritten to become the 16-bit counter comparison value (in other words, in order for this value to be transferred to the CCR0 and CCR1 buffer registers), it is necessary to rewrite the TPnCCR0 register and then write to the TPnCCR1 register before the 16-bit counter value and the CCR0 buffer register value match. Therefore, the values of the TPnCCR0 and TPnCCR1 registers are transferred to the CCR0 and CCR1 buffer registers upon a match between the count value of the 16-bit counter and the value of the CCR0 buffer register. Thus even when wishing only to rewrite the value of the TPnCCR0 register, also write the same value (same as value of the TPnCCR1 register already set) to the TPnCCR1 register.

Figure 7-6. Flowchart of Basic Operation for Batch Write

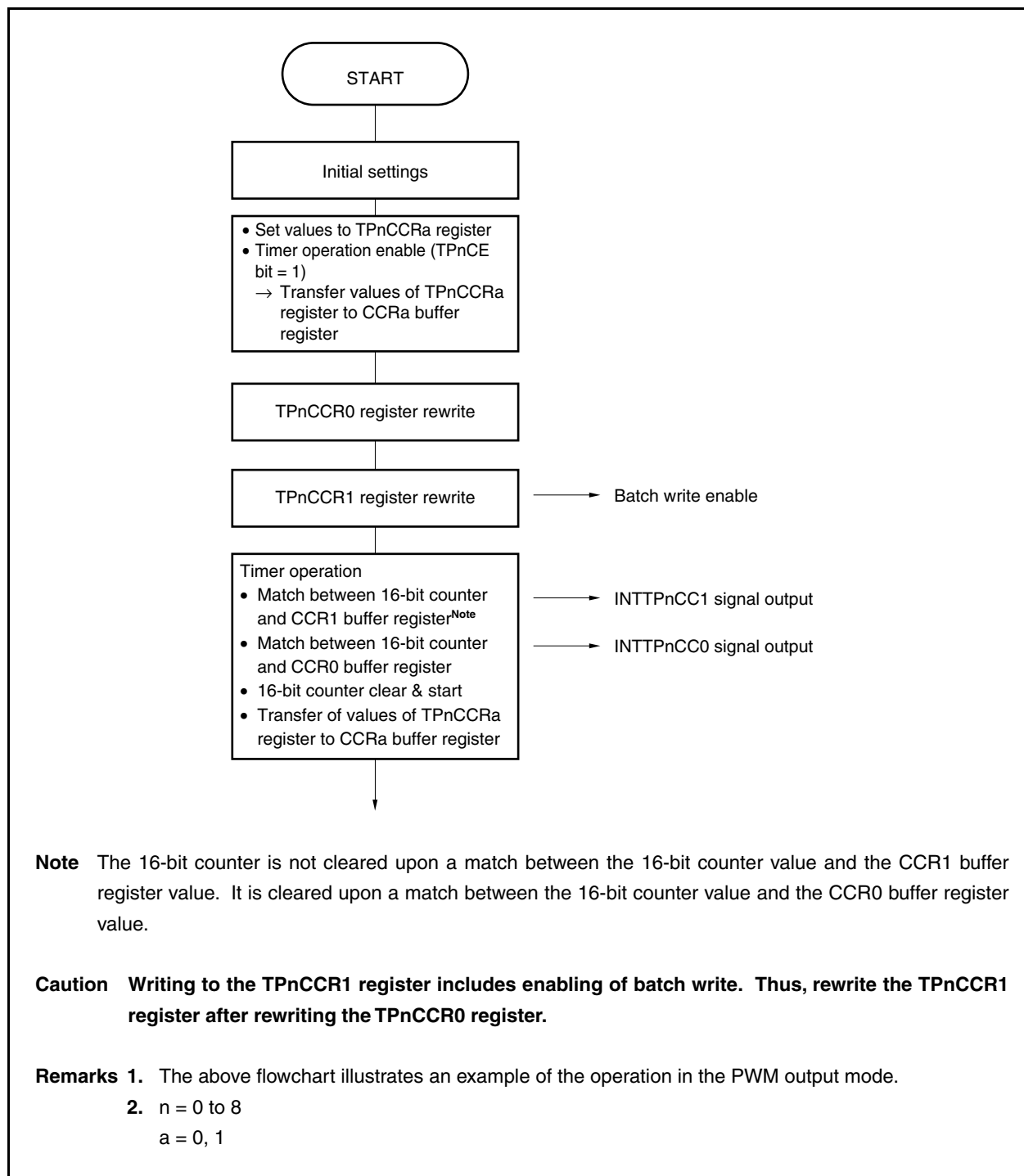
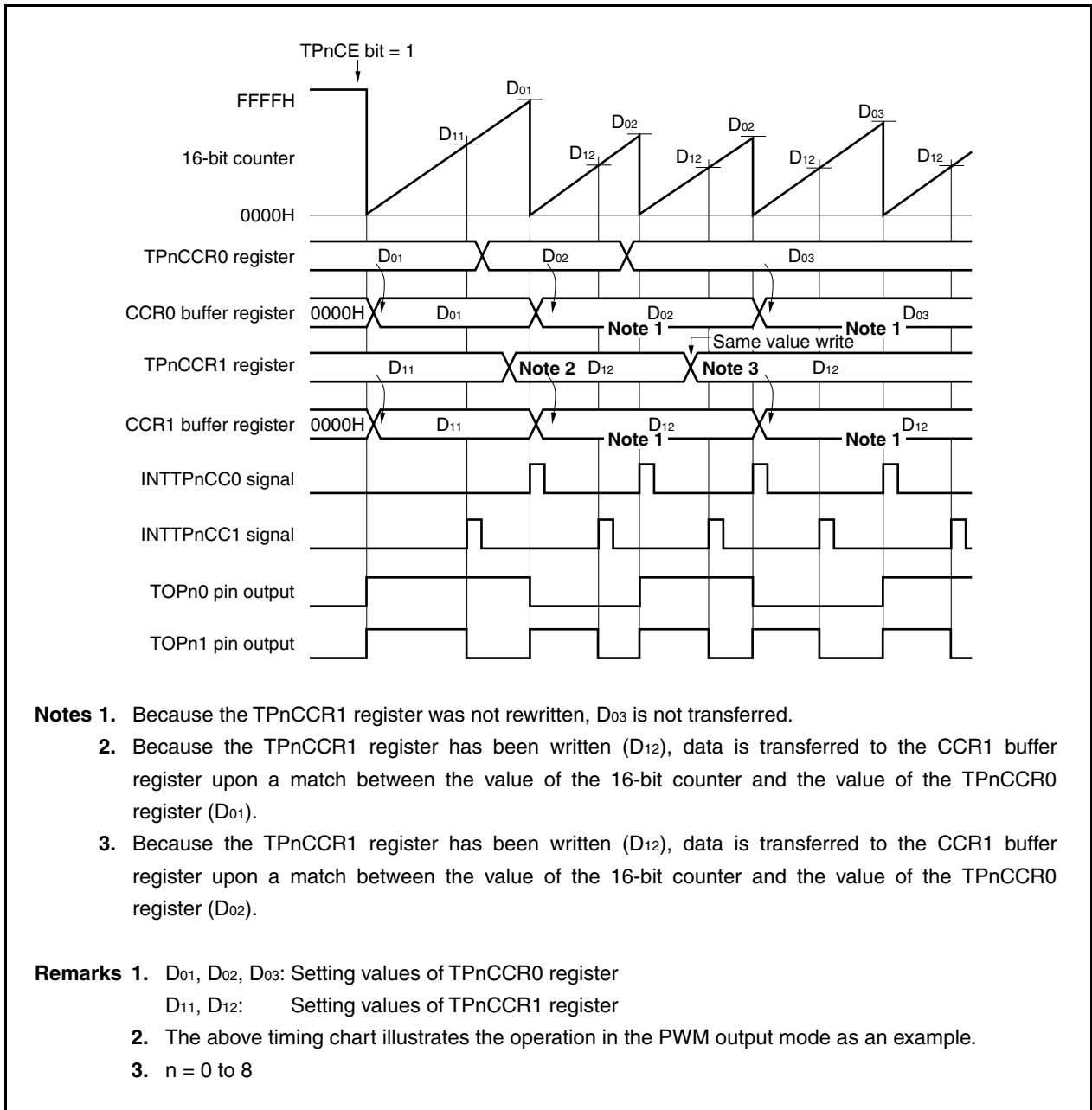

Figure 7-7. Timing of Batch Write



**7.6.1 Interval timer mode (TPnMD2 to TPnMD0 bits = 000)**

In the interval timer mode, an interrupt request signal (INTTPnCC0) is generated at the interval set by the TPnCCR0 register if the TPnCTL0.TPnCE bit is set to 1. A square wave with a duty factor of 50% whose half cycle is equal to the interval can be output from the TOPn0 pin.

The TPnCCR1 register is not used in the interval timer mode. However, the set value of the TPnCCR1 register is transferred to the CCR1 buffer register, and when the count value of the 16-bit counter matches the value of the CCR1 buffer register, a compare match interrupt request signal (INTTPnCC1) is generated. In addition, a square wave with a duty factor of 50%, which is inverted when the INTTPnCC1 signal is generated, can be output from the TOPn1 pin.

The value of the TPnCCR0 and TPnCCR1 registers can be rewritten even while the timer is operating.

**Figure 7-8. Configuration of Interval Timer**

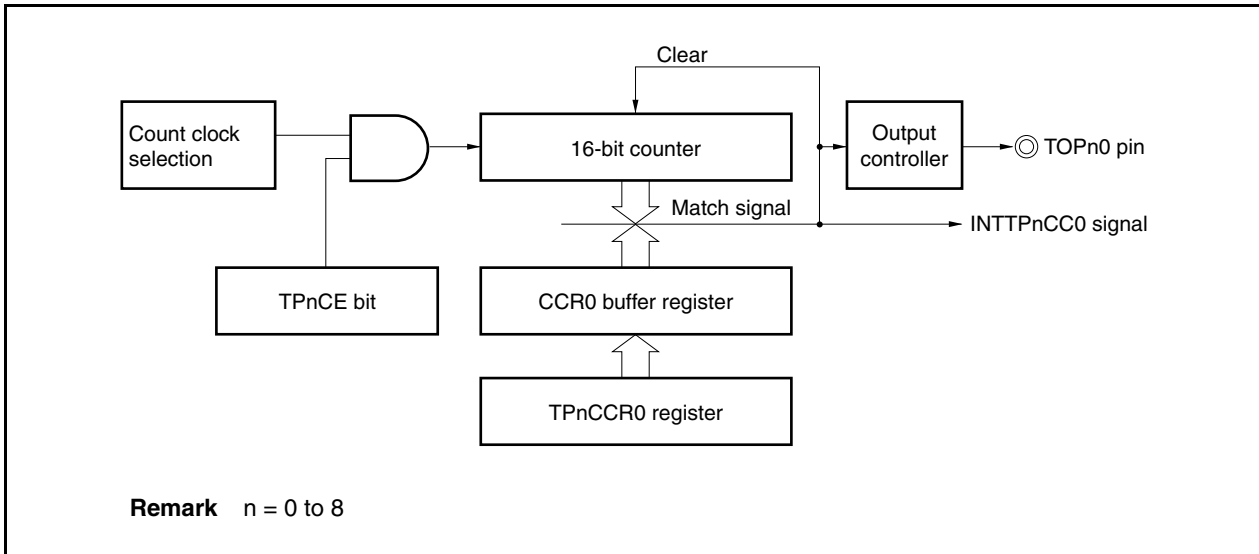

**Figure 7-9. Basic Timing of Operation in Interval Timer Mode**

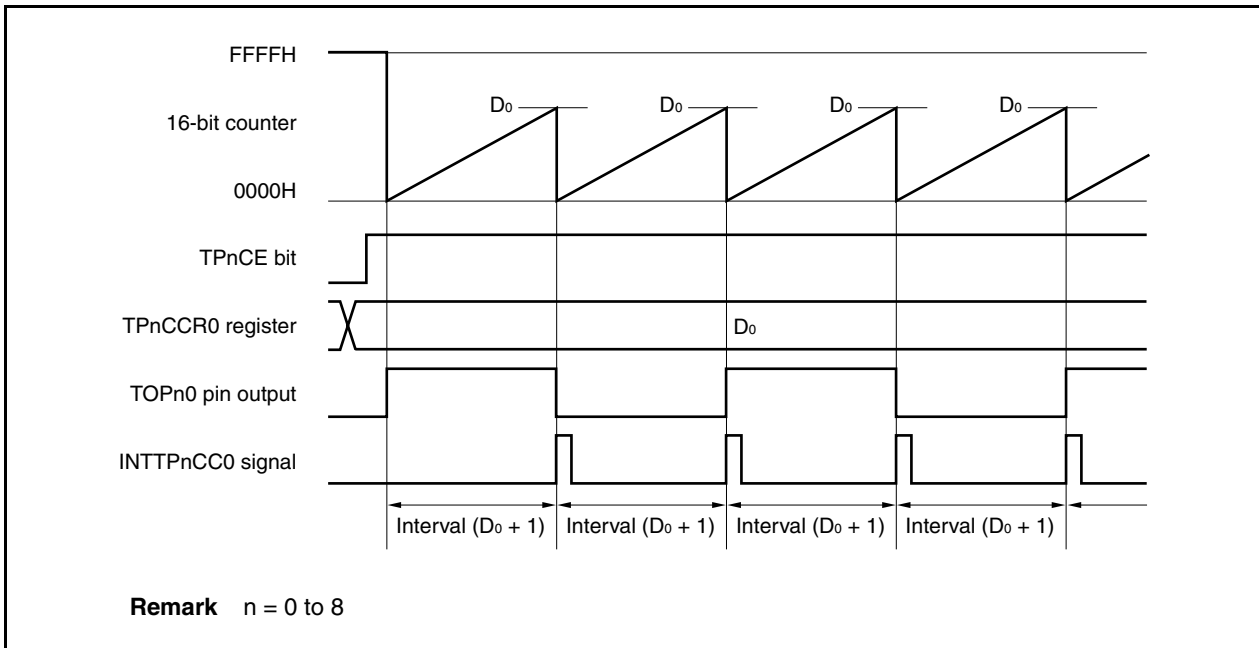

When the TPnCE bit is set to 1, the value of the 16-bit counter is cleared from FFFFH to 0000H in synchronization with the count clock, and the counter starts counting. At this time, the output of the TOPn0 pin is inverted. Additionally, the set value of the TPnCCR0 register is transferred to the CCR0 buffer register.

When the count value of the 16-bit counter matches the value of the CCR0 buffer register, the 16-bit counter is cleared to 0000H, the output of the TOPn0 pin is inverted, and a compare match interrupt request signal (INTTPnCC0) is generated.

The interval can be calculated by the following expression.

$$\text{Interval} = (\text{Set value of TPnCCR0 register} + 1) \times \text{Count clock cycle}$$

**Remark** n = 0 to 8

**Figure 7-10. Register Setting for Interval Timer Mode Operation (1/3)**

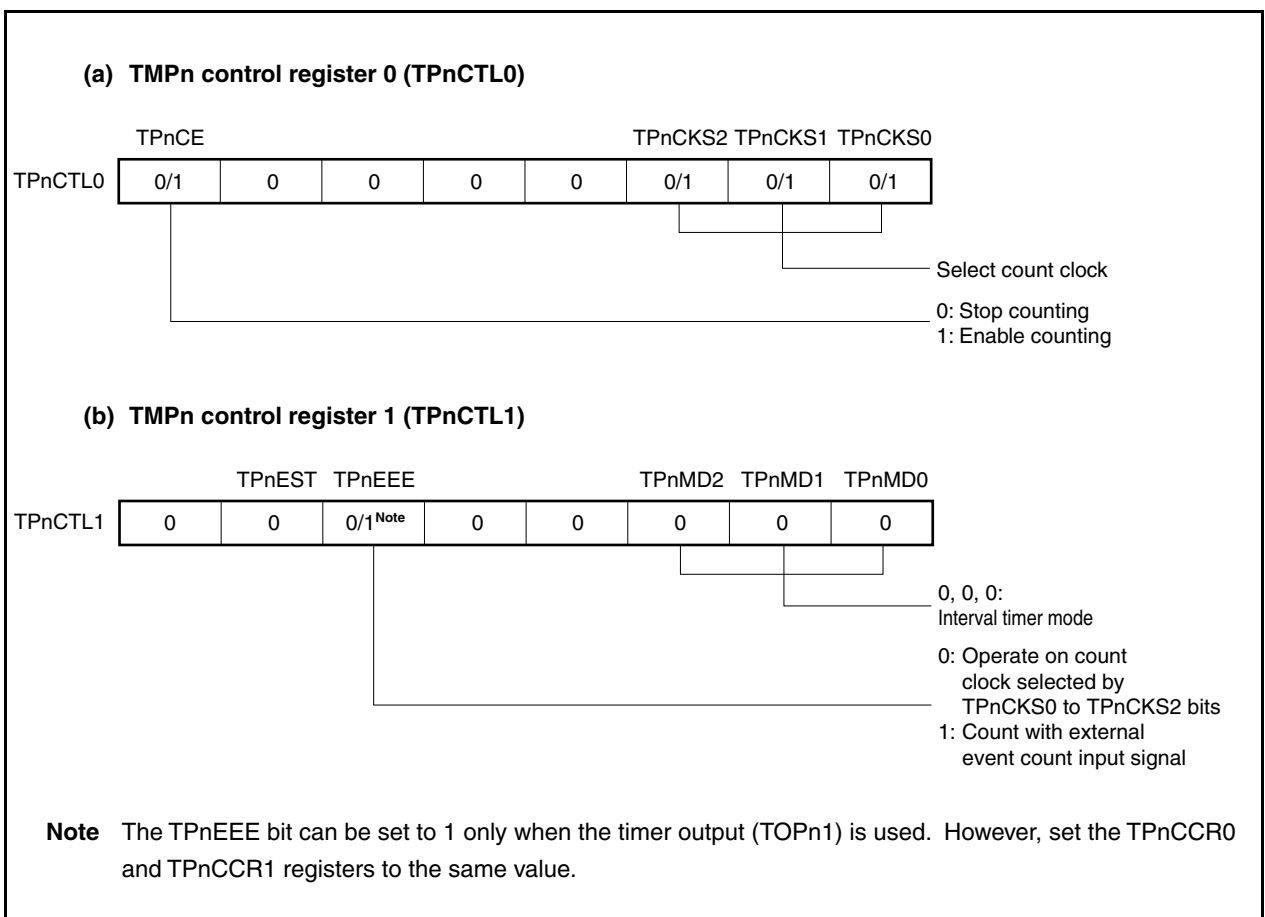

Figure 7-10. Register Setting for Interval Timer Mode Operation (2/3)

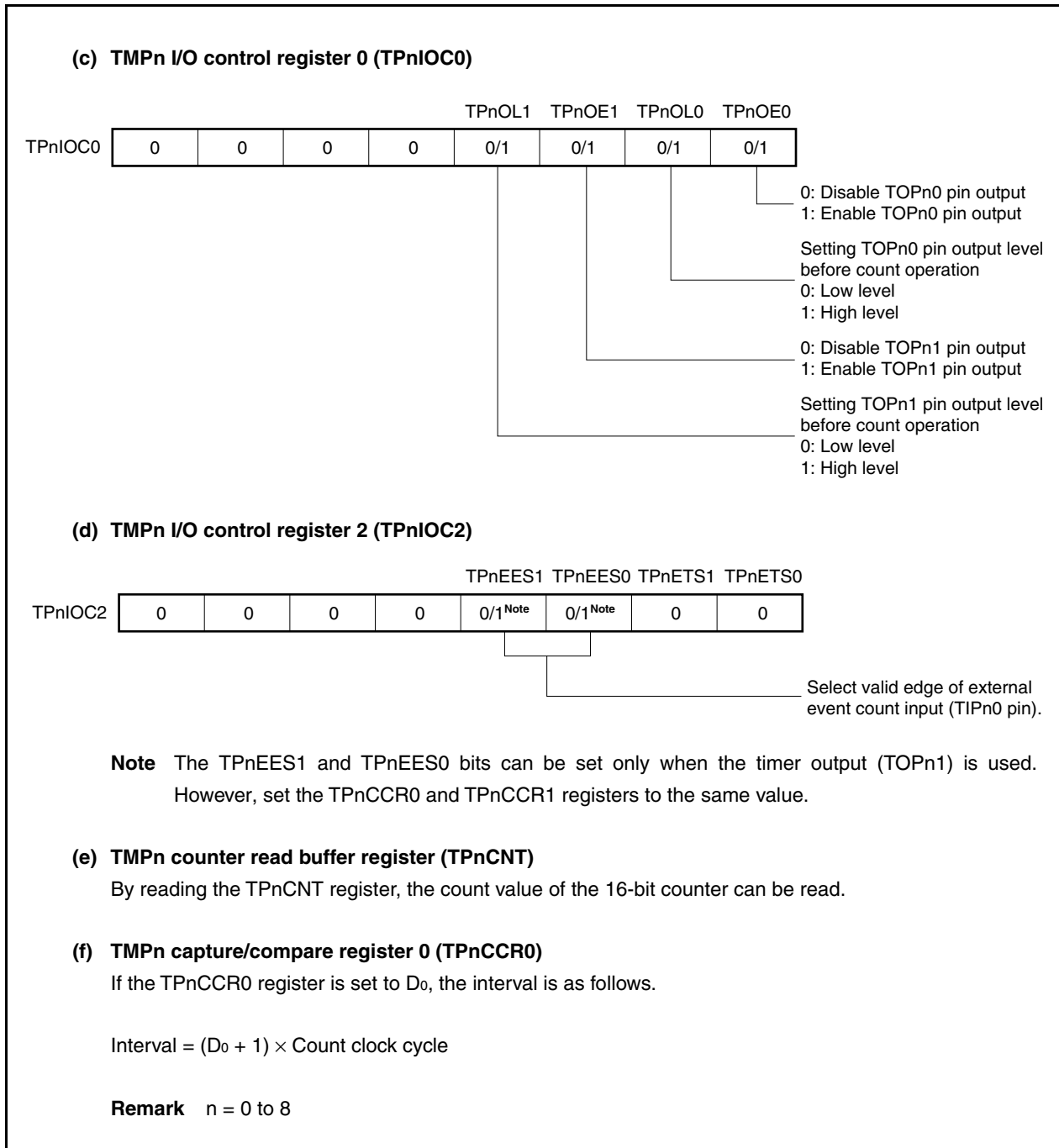



Figure 7-10. Register Setting for Interval Timer Mode Operation (3/3)

**(g) TMPn capture/compare register 1 (TPnCCR1)**

The TPnCCR1 register is not used in the interval timer mode. However, the set value of the TPnCCR1 register is transferred to the CCR1 buffer register. When the count value of the 16-bit counter matches the value of the CCR1 buffer register, the TOPn1 pin output is inverted and a compare match interrupt request signal (INTTPnCC1) is generated.

By setting this register to the same value as the value set in the TPnCCR0 register, a square wave with a duty factor of 50% can be output from the TOPn1 pin.

When the TPnCCR1 register is not used, it is recommended to set its value to FFFFH. Also mask the register by the interrupt mask flag (TPnCCIC1.TPnCCMK1).

**Remarks** 1. TMPn I/O control register 1 (TPnIOC1) and TMPn option register 0 (TPnOPT0) are not used in the interval timer mode.

2. n = 0 to 8

(1) Interval timer mode operation flow

Figure 7-11. Software Processing Flow in Interval Timer Mode

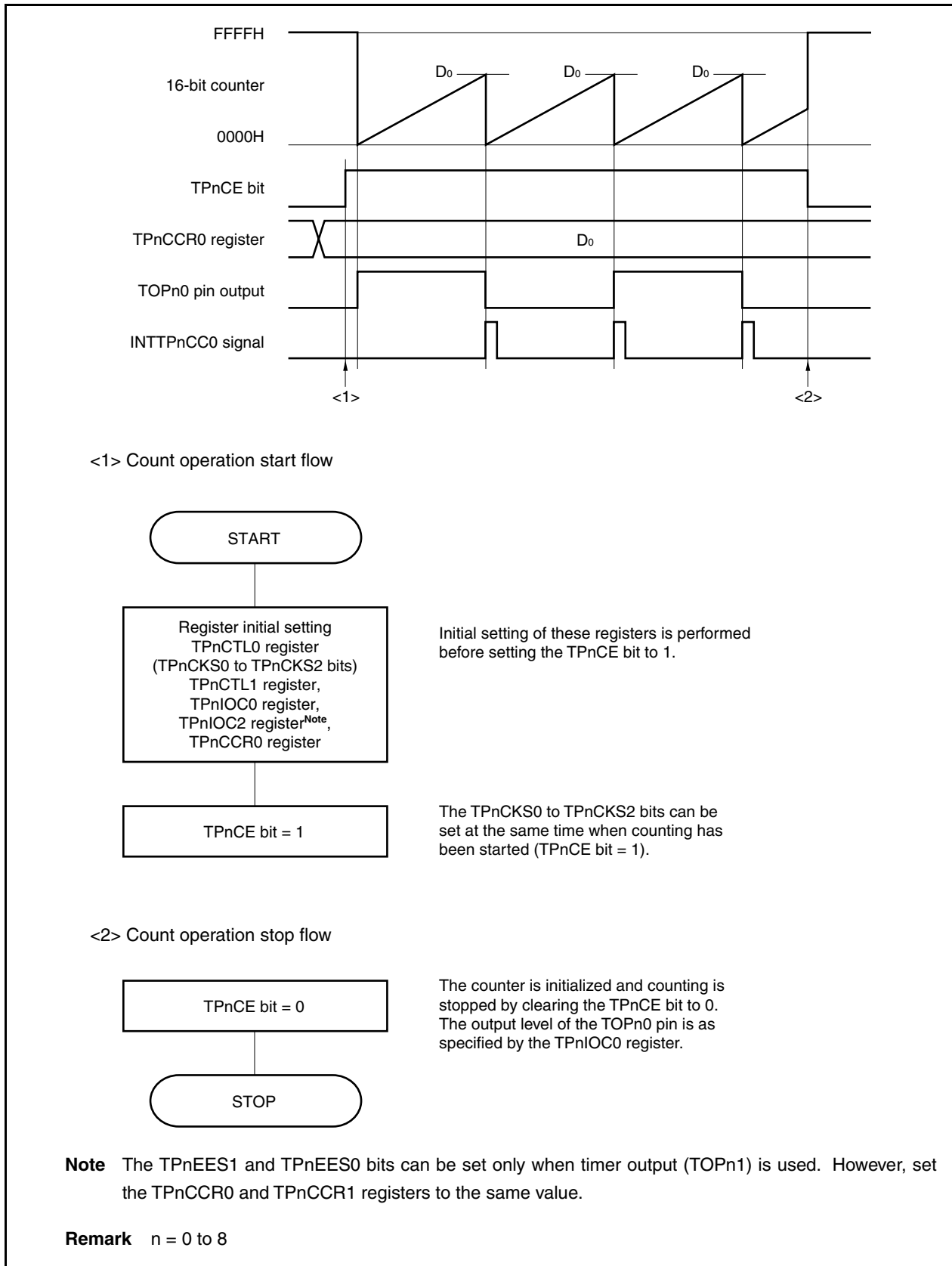

(2) Interval timer mode operation timing

(a) Operation if TPnCCR0 register is set to 0000H

If the TPnCCR0 register is set to 0000H, the INTTPnCC0 signal is generated at each count clock, and the output of the TOPn0 pin is inverted.

The value of the 16-bit counter is always 0000H.

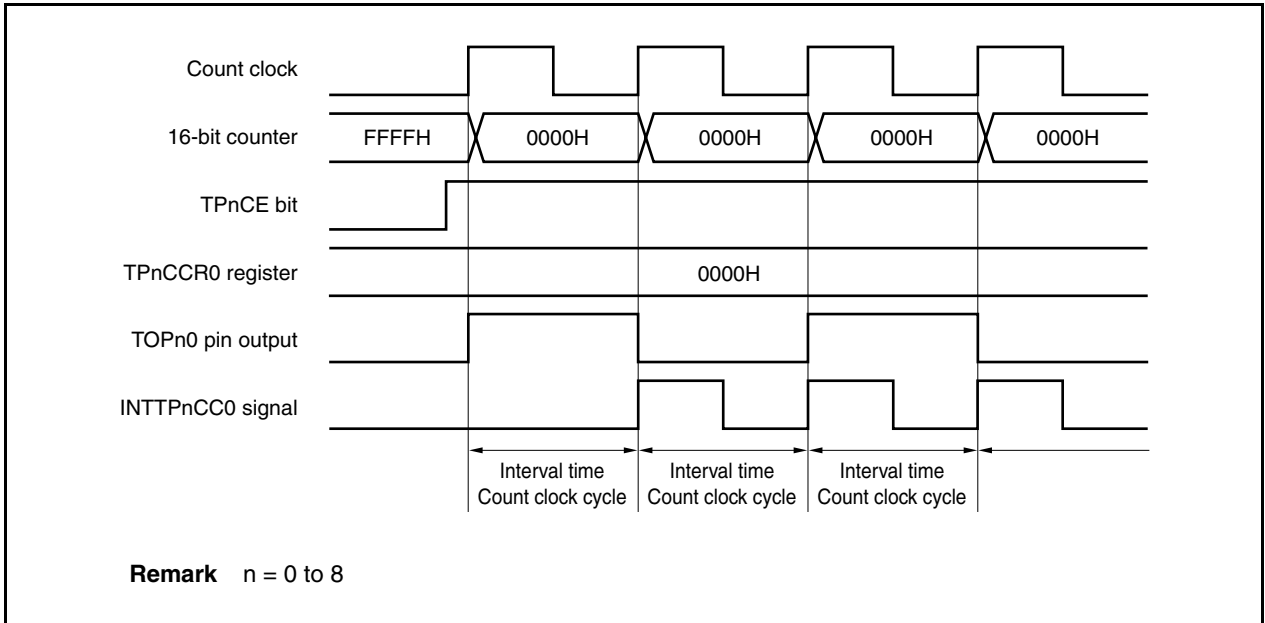

**(b) Operation if TPnCCR0 register is set to FFFFH**

If the TPnCCR0 register is set to FFFFH, the 16-bit counter counts up to FFFFH. The counter is cleared to 0000H in synchronization with the next count-up timing. The INTTPnCC0 signal is generated and the output of the TOPn0 pin is inverted. At this time, an overflow interrupt request signal (INTTPnOV) is not generated, nor is the overflow flag (TPnOPT0.TPnOVF bit) set to 1.

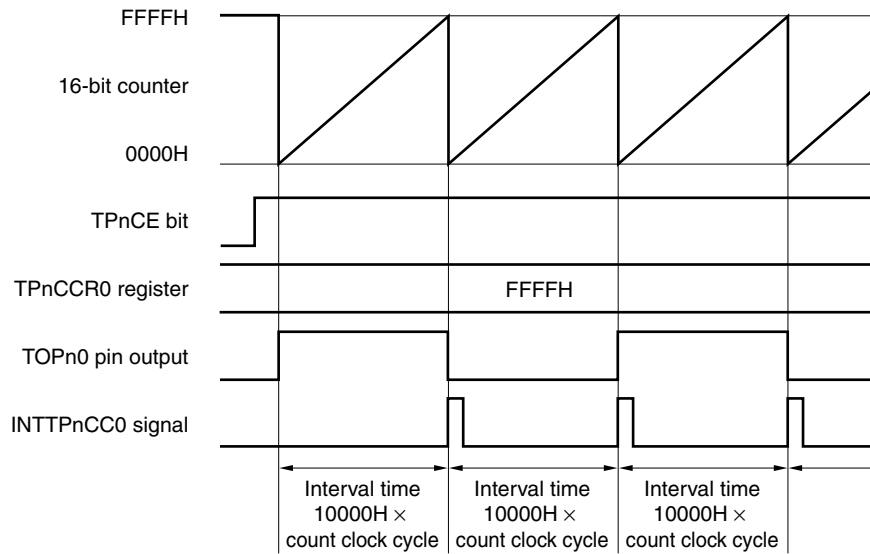

**Remark** n = 0 to 8

**(c) Notes on rewriting TPnCCR0 register**

When the value of the TPnCCR0 register is rewritten to a smaller value during counting, the 16-bit counter may overflow. If there is a possibility of overflow, stop counting and then change the set value.

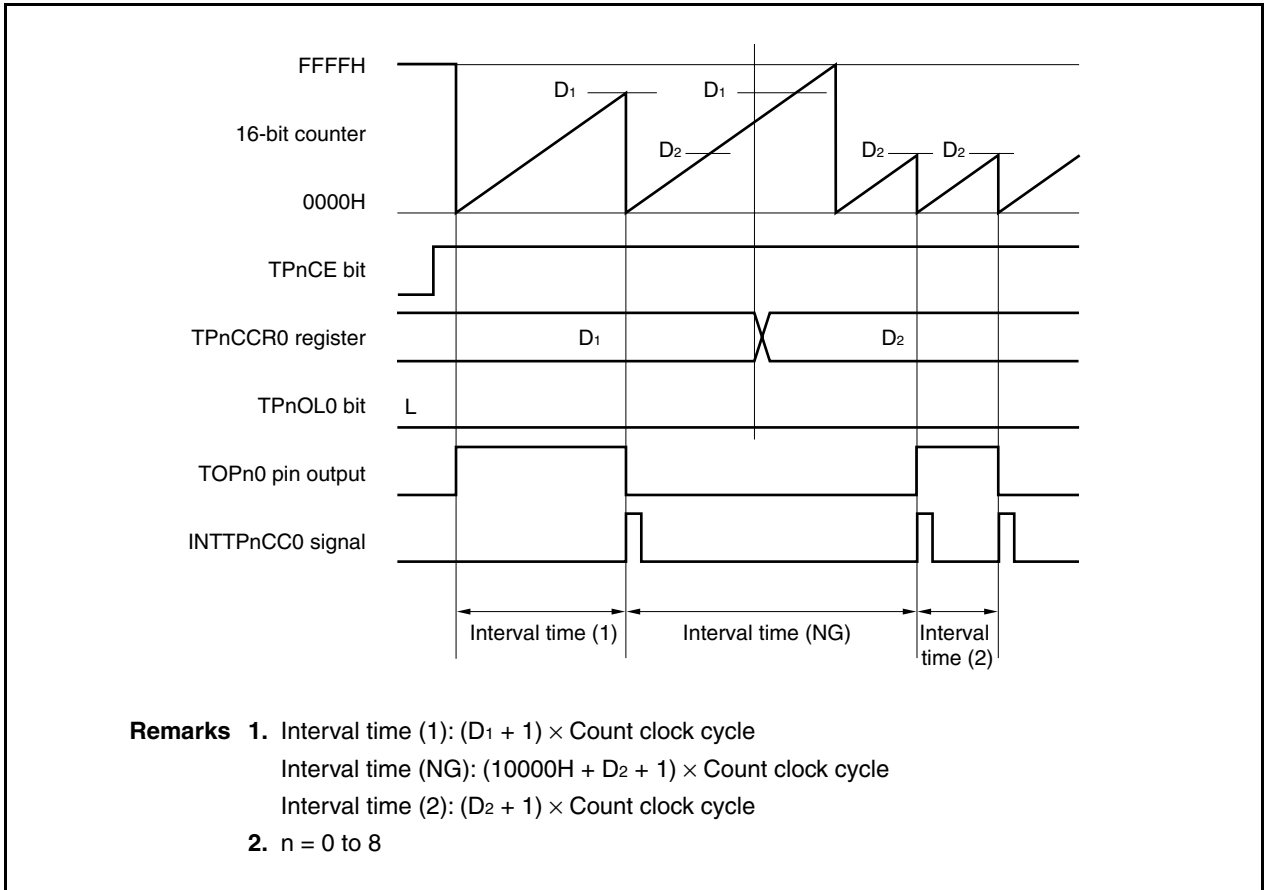

If the value of the TPnCCR0 register is changed from  $D_1$  to  $D_2$  while the count value is greater than  $D_2$  but less than  $D_1$ , the count value is transferred to the CCR0 buffer register as soon as the TPnCCR0 register has been rewritten. Consequently, the value of the 16-bit counter that is compared is  $D_2$ .

Because the count value has already exceeded  $D_2$ , however, the 16-bit counter counts up to FFFFH, overflows, and then counts up again from 0000H. When the count value matches  $D_2$ , the INTTPnCC0 signal is generated and the output of the TOPn0 pin is inverted.

Therefore, the INTTPnCC0 signal may not be generated at the interval time " $(D_1 + 1) \times \text{Count clock cycle}$ " or " $(D_2 + 1) \times \text{Count clock cycle}$ " originally expected, but may be generated at an interval of " $(10000H + D_2 + 1) \times \text{Count clock period}$ ".

## (d) Operation of TPnCCR1 register

Figure 7-12. Configuration of TPnCCR1 Register

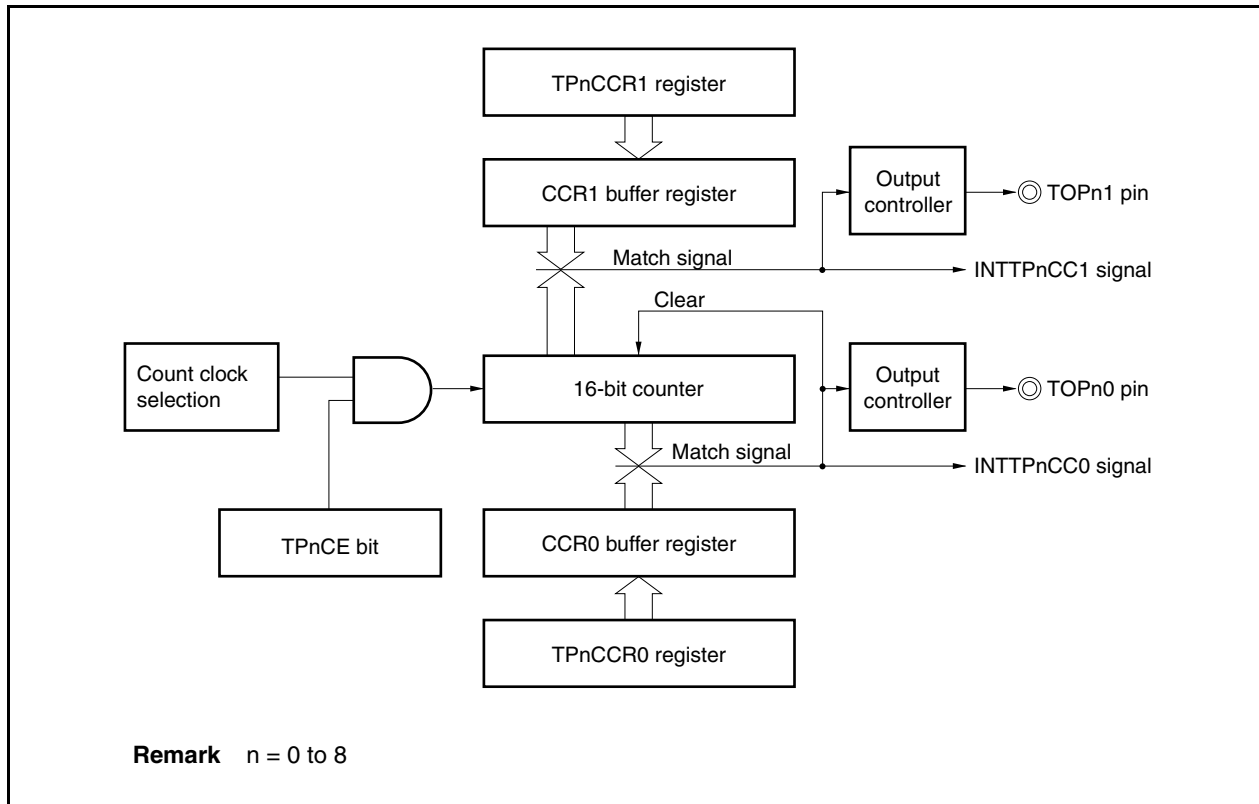

When the TPnCCR1 register is set to the same value as the TPnCCR0 register, the INTTPnCC1 signal is generated at the same timing as the INTTPnCC0 signal and the TOPn1 pin output is inverted. In other words, a square wave with a duty factor of 50% can be output from the TOPn1 pin.

The following shows the operation when the TPnCCR1 register is set to other than the value set in the TPnCCR0 register.

If the set value of the TPnCCR1 register is less than the set value of the TPnCCR0 register, the INTTPnCC1 signal is generated once per cycle. At the same time, the output of the TOPn1 pin is inverted. The TOPn1 pin outputs a square wave with a duty factor of 50% after outputting a short-width pulse.

**Figure 7-13. Timing Chart When  $D_{01} \geq D_{11}$**

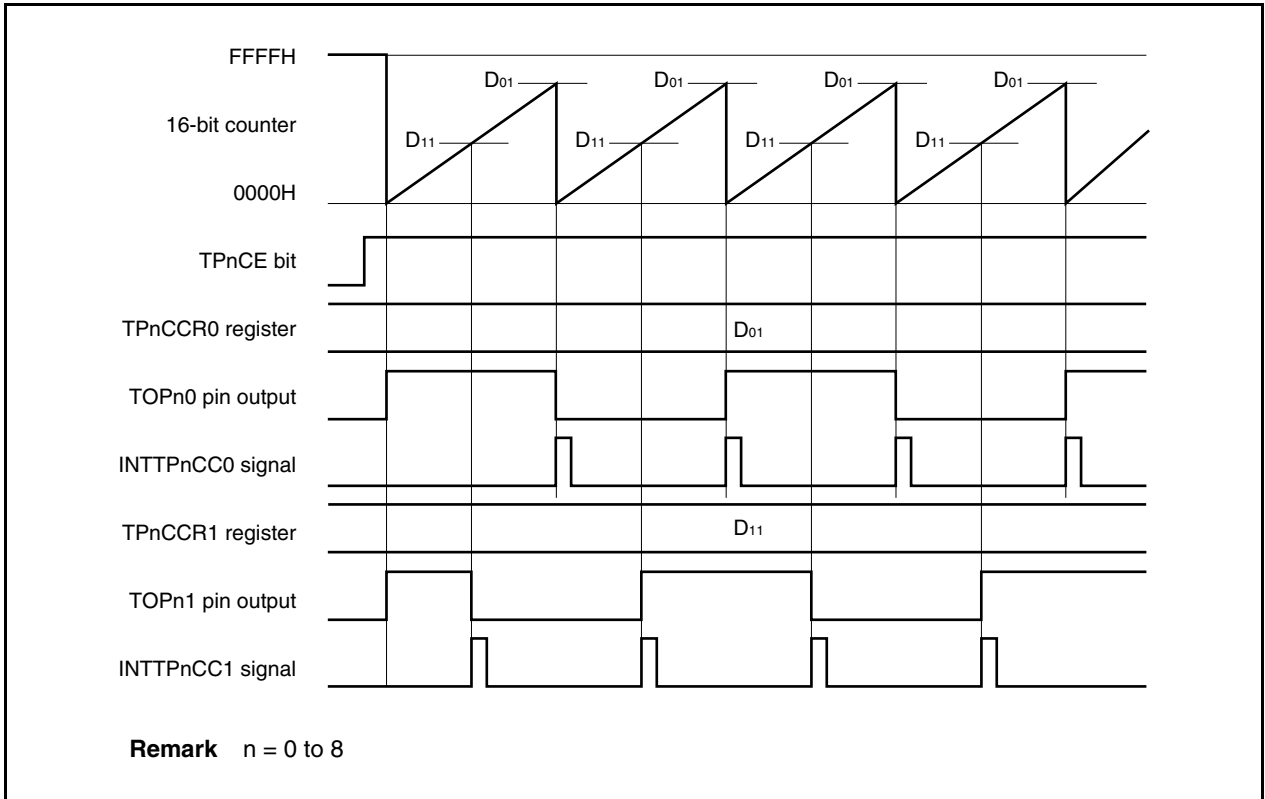

If the set value of the TPnCCR1 register is greater than the set value of the TPnCCR0 register, the count value of the 16-bit counter does not match the value of the TPnCCR1 register. Consequently, the INTTPnCC1 signal is not generated, nor is the output of the TOPn1 pin changed. When the TPnCCR1 register is not used, it is recommended to set its value to FFFFH.

Figure 7-14. Timing Chart When  $D_{01} < D_{11}$

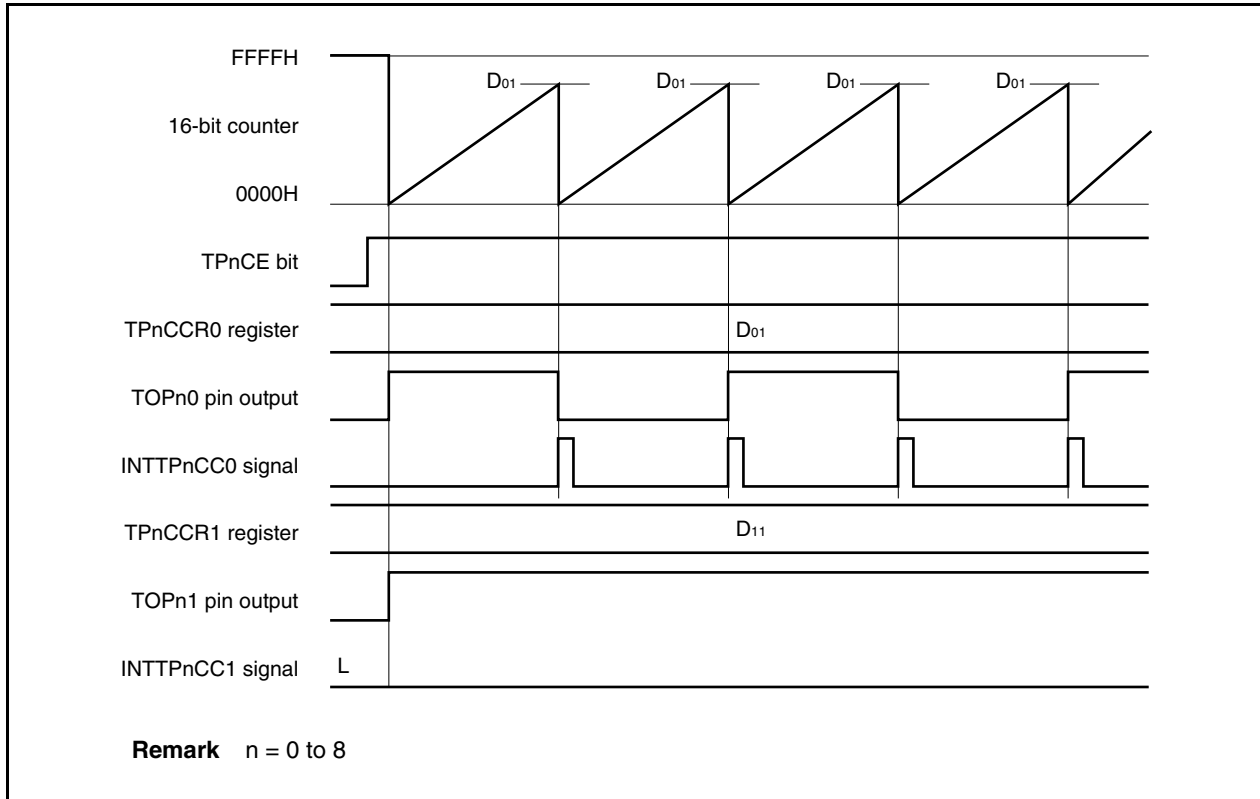



(3) Operation by external event count input (TIPn0)

(a) Operation

To count the 16-bit counter at the valid edge of external event count input (TIPn0) in the interval timer mode, the valid edge of the external event count input is necessary once because the 16-bit counter is cleared from FFFFH to 0000H immediately after the TPnCE bit is set from 0 to 1.

When 0001H is set to both the TPnCCR0 and TPnCCR1 registers, the TOPn1 pin output is inverted each time the 16-bit counter counts twice.

The TPnCTL1.TPnEEE bit can be set to 1 in the interval timer mode only when the timer output (TOPn1) is used with the external event count input.

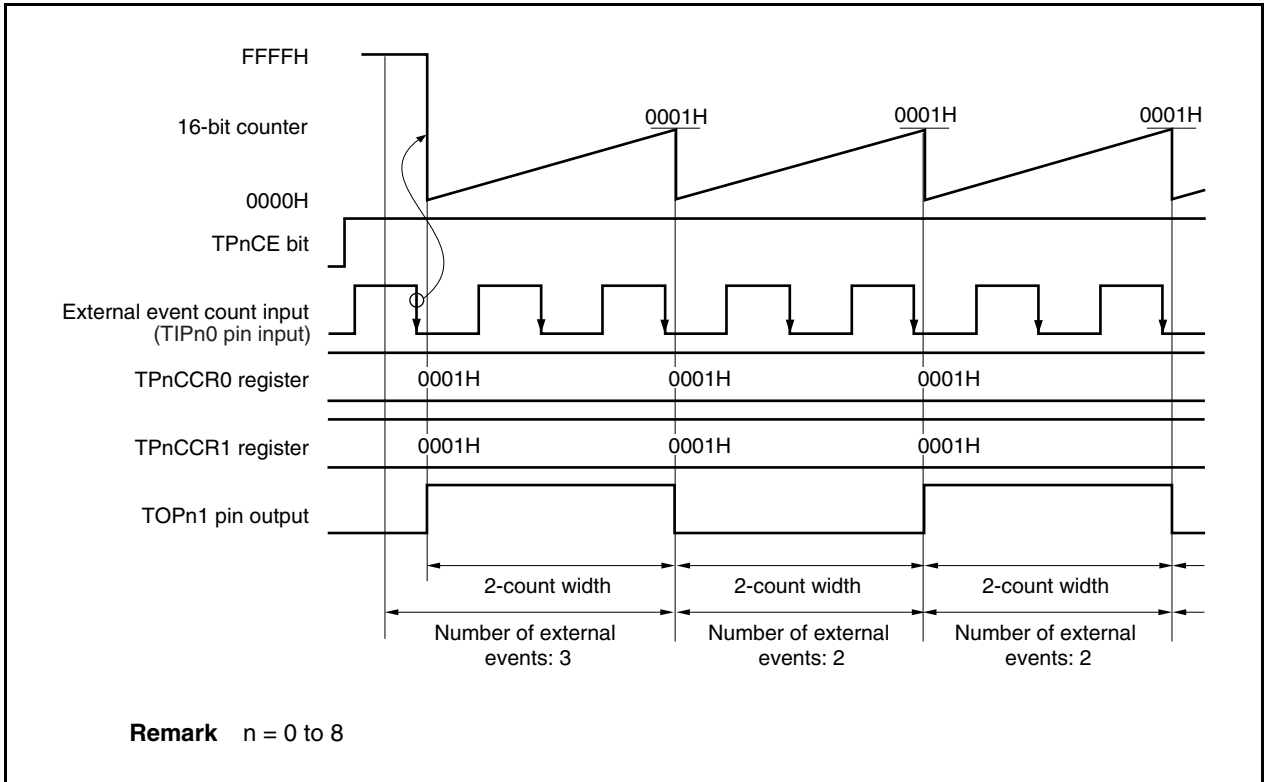

### 7.6.2 External event count mode (TPnMD2 to TPnMD0 bits = 001)

In the external event count mode, the valid edge of the external event count input (TIPn0) is counted when the TPnCTL0.TPnCE bit is set to 1, and an interrupt request signal (INTTPnCC0) is generated each time the number of edges set by the TPnCCR0 register have been counted. The TOPn0 and TOPn1 pins cannot be used. When using the TOPn1 pin for external event count input, set the TPnCTL1.TPnEEE bit to 1 in the interval timer mode (see 7.6.1 (3) Operation by external event count input (TIPn0)).

The TPnCCR1 register is not used in the external event count mode.

**Caution** In the external event count mode, the TPnCCR0 and TPnCCR1 registers must not be cleared to 0000H.

Figure 7-15. Configuration in External Event Count Mode

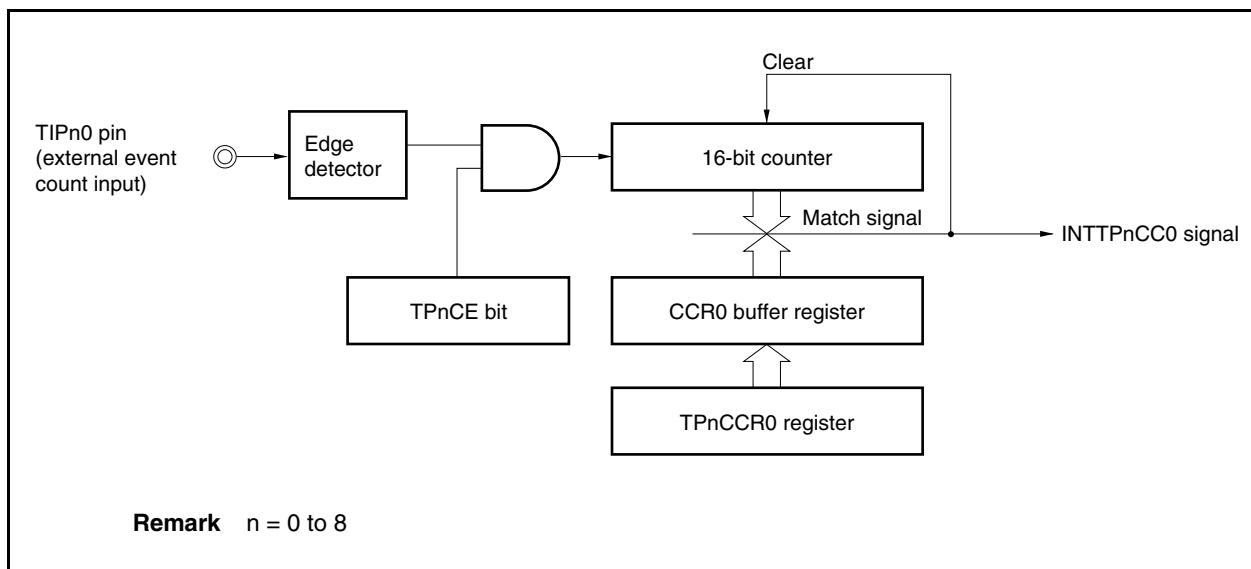
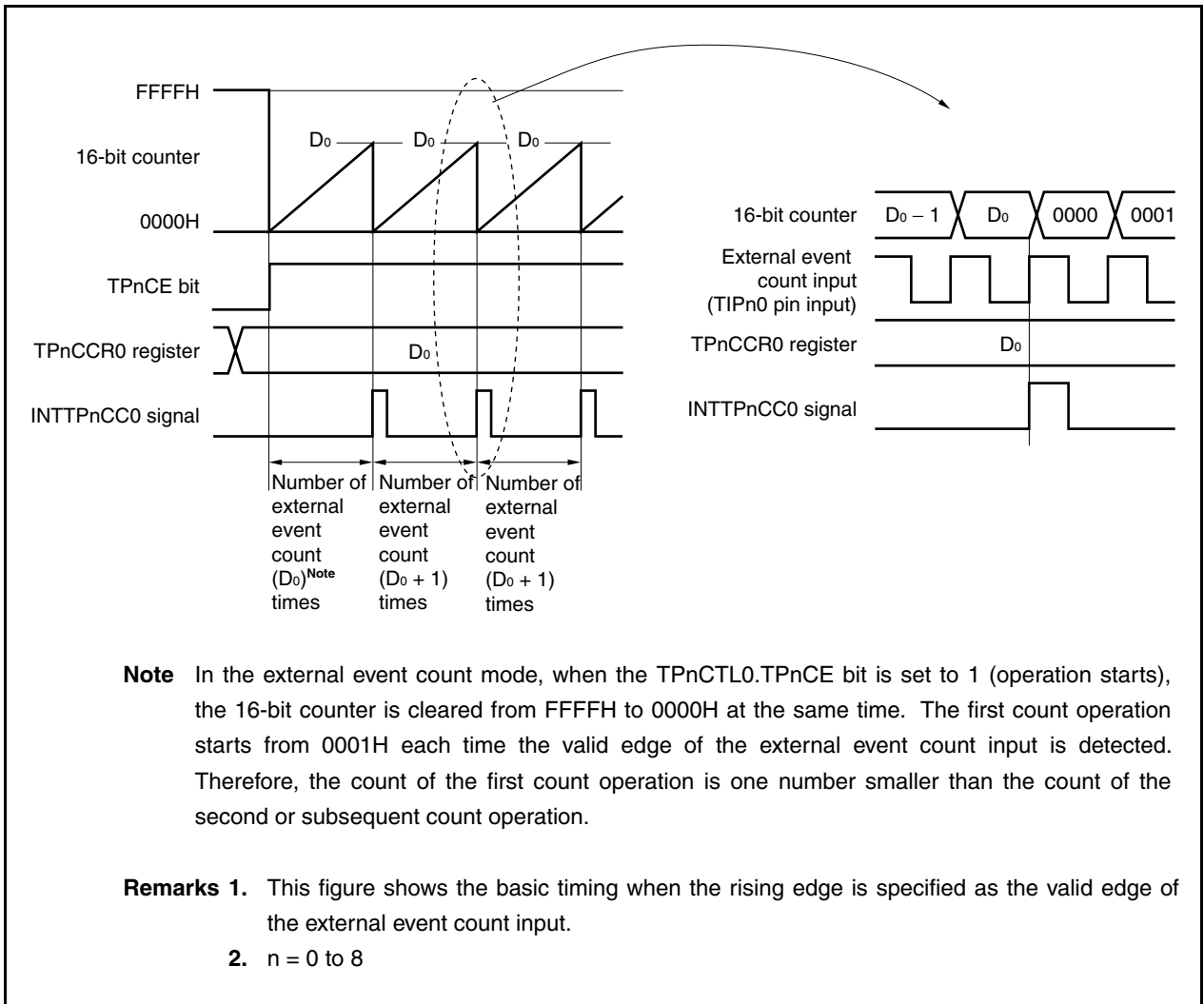

Figure 7-16. Basic Timing in External Event Count Mode



When the TPnCE bit is set to 1, the value of the 16-bit counter is cleared from FFFFH to 0000H. The counter counts each time the valid edge of external event count input is detected. Additionally, the set value of the TPnCCR0 register is transferred to the CCR0 buffer register.

When the count value of the 16-bit counter matches the value of the CCR0 buffer register, the 16-bit counter is cleared to 0000H, and a compare match interrupt request signal (INTTPnCC0) is generated.

The INTTPnCC0 signal is generated for the first time when the valid edge of the external event count input has been detected “value set to TPnCCR0 register” times. After that, the INTTPnCC0 signal is generated each time the valid edge of the external event count input has been detected “value set to TPnCCR0 register + 1” times.

**Figure 7-17. Register Setting for Operation in External Event Count Mode (1/2)**

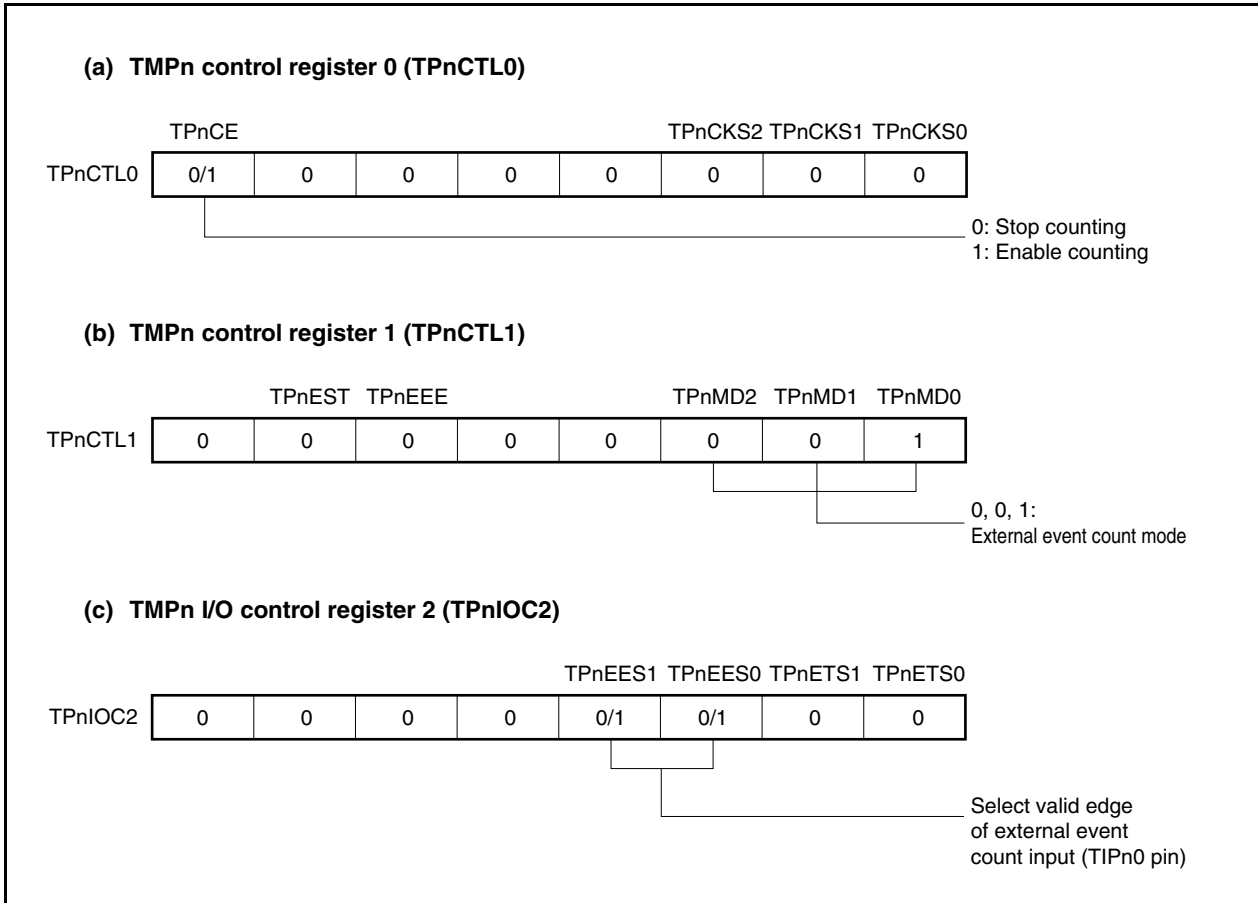

Figure 7-17. Register Setting for Operation in External Event Count Mode (2/2)

**(d) TMPn counter read buffer register (TPnCNT)**

The count value of the 16-bit counter can be read by reading the TPnCNT register.

**(e) TMPn capture/compare register 0 (TPnCCR0)**

If the TPnCCR0 register is set to  $D_0$ , the count is cleared when the number of external events has reached ( $D_0$ ) and the first compare match interrupt request signal (INTTPnCC0) is generated. The second compare match interrupt request signal (INTTPnCC0) is generated when the number of external events has reached ( $D_0 + 1$ ).

**(f) TMPn capture/compare register 1 (TPnCCR1)**

The TPnCCR1 register is not used in the external event count mode. However, the set value of the TPnCCR1 register is transferred to the CCR1 buffer register. When the count value of the 16-bit counter matches the value of the CCR1 buffer register, a compare match interrupt request signal (INTTPnCC1) is generated.

When the TPnCCR1 registers are not used, it is recommended to set their value to FFFFH. Also mask the register by the interrupt mask flag (TPnCCIC1.TPnCCMK1).

**Cautions 1. Set the TPnIOC0 register to 00H.**

2. When an external clock is used as the count clock, the external clock can be input only from the TIPn0 pin. At this time, set the TPnIOC1.TPnIS1 and TPnIOC1.TPnIS0 bits to 00 (capture trigger input (TIPn0 pin): no edge detection).

**Remarks 1.** TMPn I/O control register 1 (TPnIOC1) and TMPn option register 0 (TPnOPT0) are not used in the external event count mode.

2.  $n = 0$  to 8

(1) External event count mode operation flow

Figure 7-18. Flow of Software Processing in External Event Count Mode

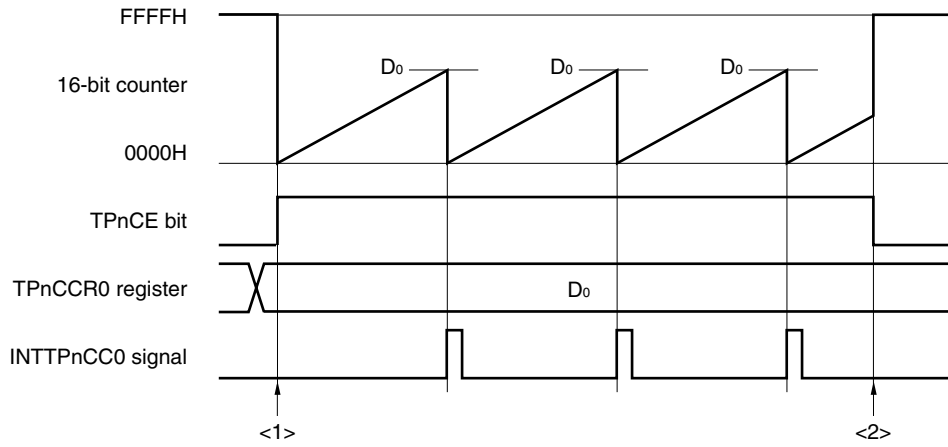

<1> Count operation start flow

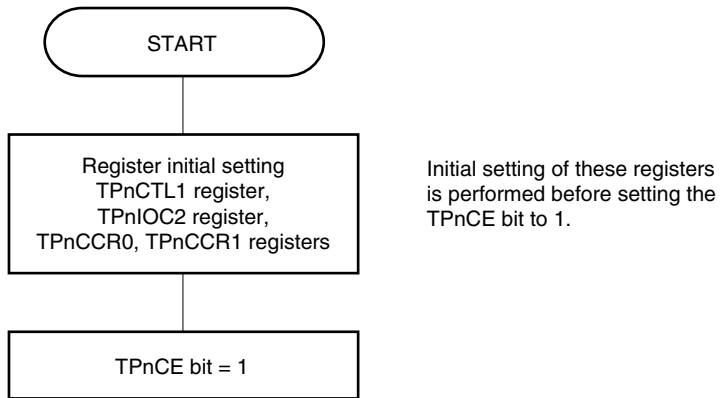

<2> Count operation stop flow

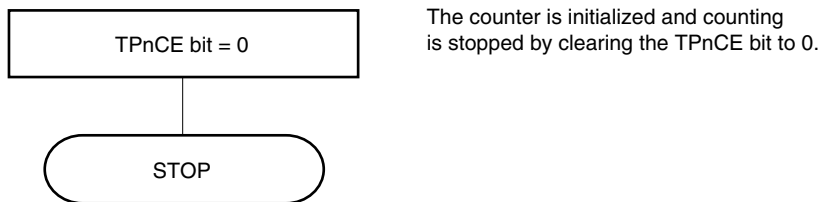

**Remark** n = 0 to 8

(2) Operation timing in external event count mode

**Cautions 1.** In the external event count mode, setting the TPnCCR0 and TPnCCR1 registers to 0000H is disabled.

**2.** In the external event count mode, use of the timer output (TOPn0, TOPn1) is disabled. If performing external event count input (TIPn0) using timer output (TOPn1), set the interval timer mode to enable the count clock operation (TPnCTL1.TPnEEE bit = 1) for the external event count input (refer to 7.6.1 (3) Operation by external event count input (TIPn0)).

**(a) Operation if TPnCCR0 register is set to FFFFH**

If the TPnCCR0 register is set to FFFFH, the 16-bit counter counts to FFFFH each time the valid edge of the external event count signal has been detected. The 16-bit counter is cleared to 0000H in synchronization with the next count-up timing, and the INTTPnCC0 signal is generated. At this time, the TPnOPT0.TPnOVF bit is not set.

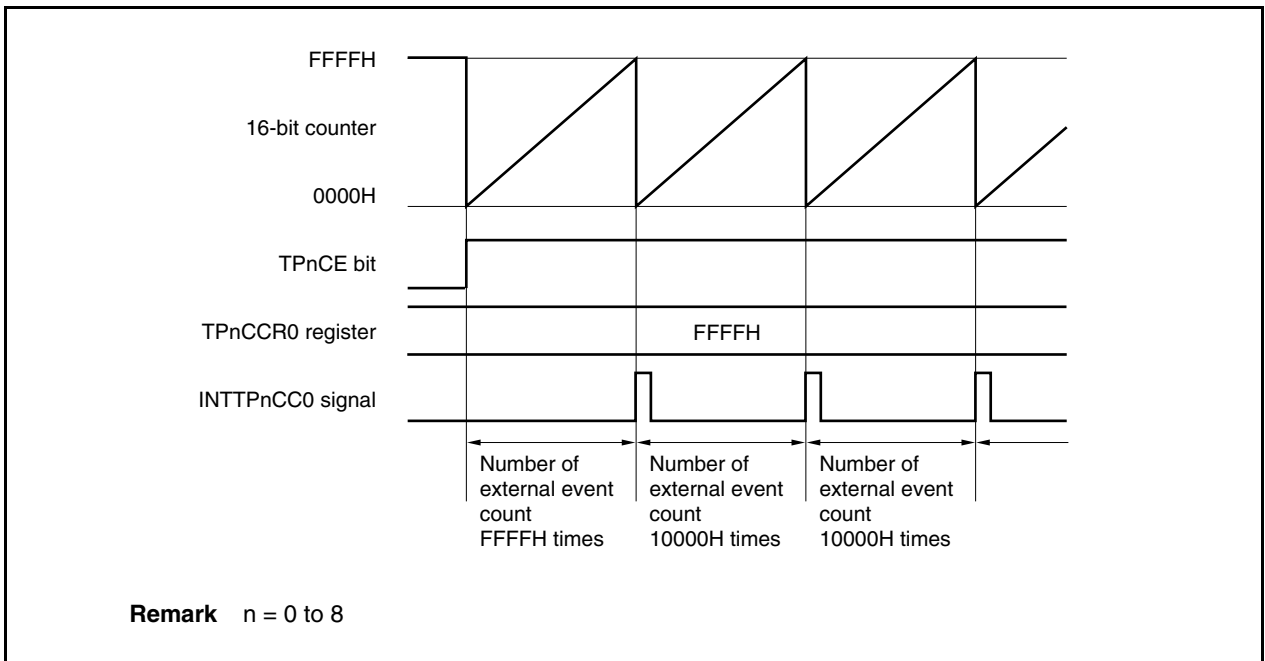

**(b) Notes on rewriting the TPnCCR0 register**

If the value of the TPnCCR0 register is rewritten to a smaller value during counting, the 16-bit counter may overflow. If there is a possibility of overflow, stop counting and then change the set value.

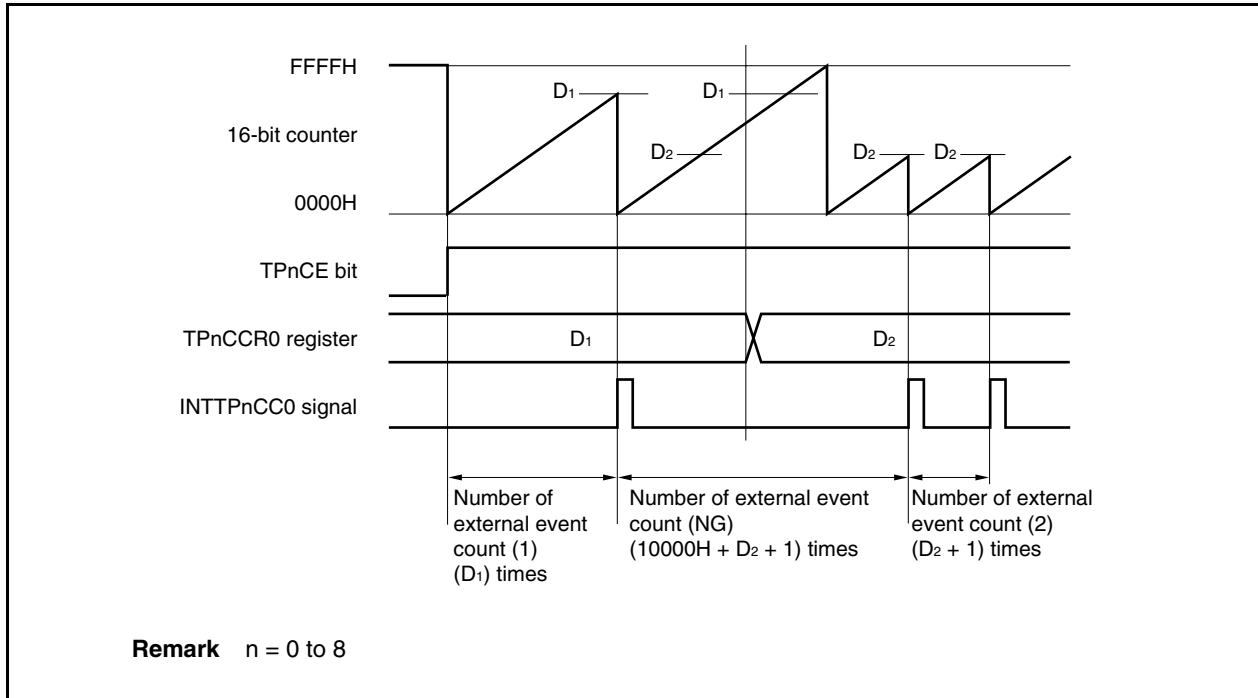

If the value of the TPnCCR0 register is changed from D<sub>1</sub> to D<sub>2</sub> while the count value is greater than D<sub>2</sub> but less than D<sub>1</sub>, the count value is transferred to the CCR0 buffer register as soon as the TPnCCR0 register has been rewritten. Consequently, the value that is compared with the 16-bit counter is D<sub>2</sub>.

Because the count value has already exceeded D<sub>2</sub>, however, the 16-bit counter counts up to FFFFH, overflows, and then counts up again from 0000H. When the count value matches D<sub>2</sub>, the INTTPnCC0 signal is generated.

Therefore, the INTTPnCC0 signal may not be generated at the valid edge count of “(D<sub>1</sub> + 1) times” or “(D<sub>2</sub> + 1) times” originally expected, but may be generated at the valid edge count of “(10000H + D<sub>2</sub> + 1) times”.



(c) Operation of TPnCCR1 register

Figure 7-19. Configuration of TPnCCR1 Register

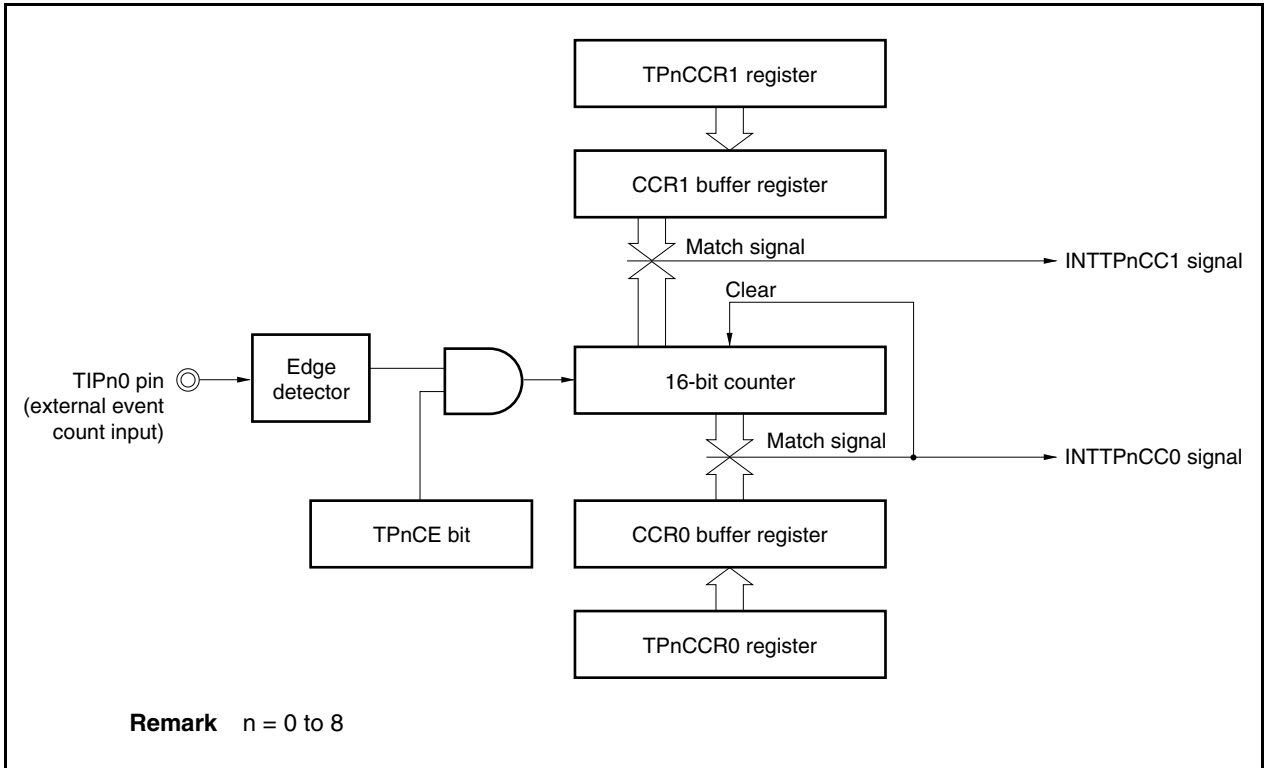

If the set value of the TPnCCR1 register is smaller than the set value of the TPnCCR0 register, the INTTPnCC1 signal is generated once per cycle.

Figure 7-20. Timing Chart When  $D_{01} \geq D_{11}$

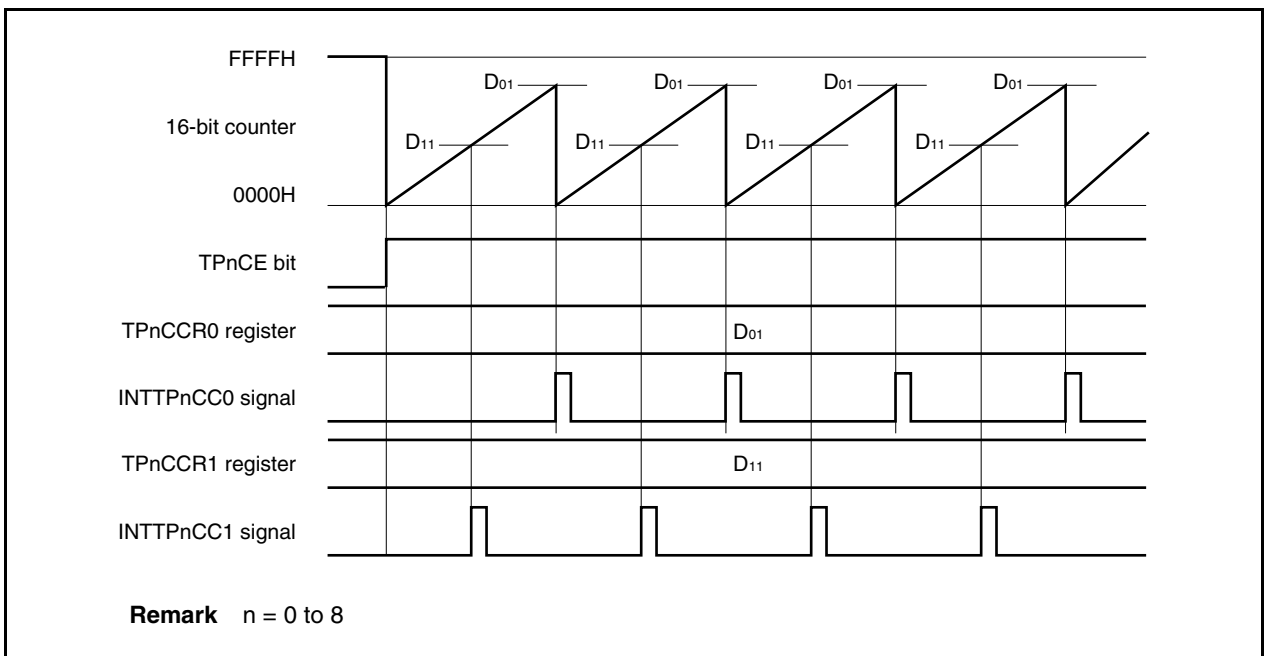

If the set value of the TPnCCR1 register is greater than the set value of the TPnCCR0 register, the INTTPnCC1 signal is not generated because the count value of the 16-bit counter and the value of the TPnCCR1 register do not match.

It is recommended to set FFFFH to the TPnCCR1 register when the TPnCCR1 register is not used.

Figure 7-21. Timing Chart When  $D_{01} < D_{11}$

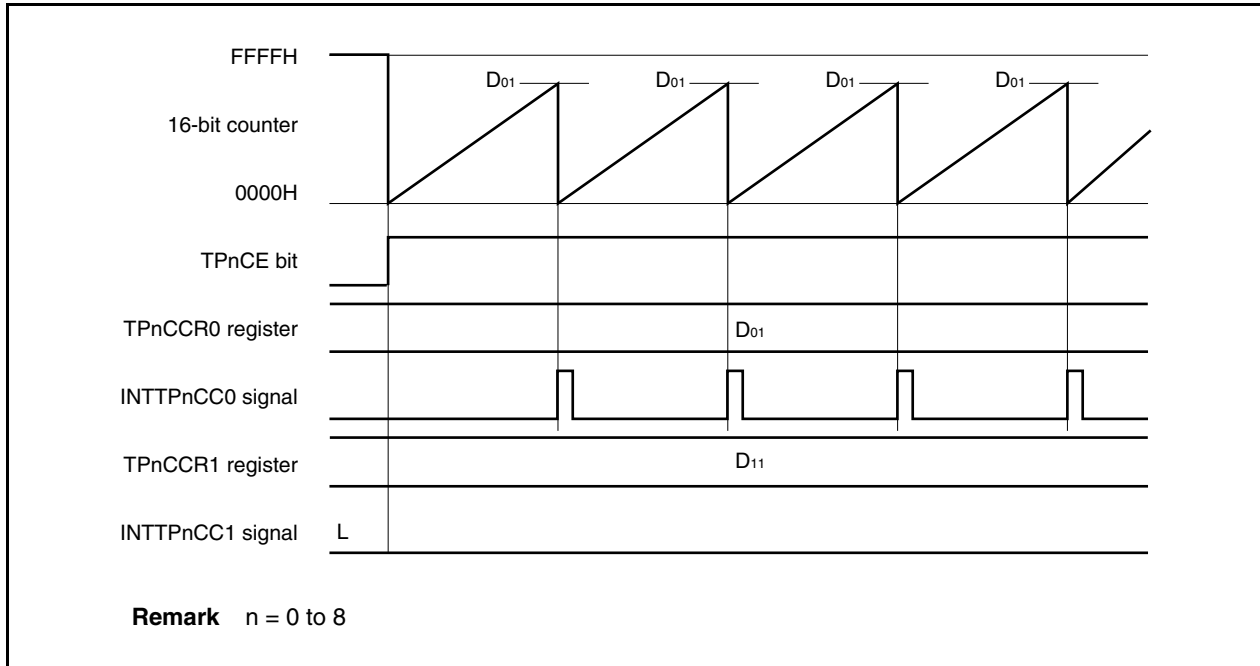

### 7.6.3 External trigger pulse output mode (TPnMD2 to TPnMD0 bits = 010)

In the external trigger pulse output mode, 16-bit timer/event counter P waits for a trigger when the TPnCTL0.TPnCE bit is set to 1. When the valid edge of an external trigger input signal is detected, 16-bit timer/event counter P starts counting, and outputs a PWM waveform from the TOPn1 pin.

Pulses can also be output by generating a software trigger instead of using the external trigger. When using a software trigger, a square wave that has one cycle of the PWM waveform as half its cycle can also be output from the TOPn0 pin.

Figure 7-22. Configuration in External Trigger Pulse Output Mode

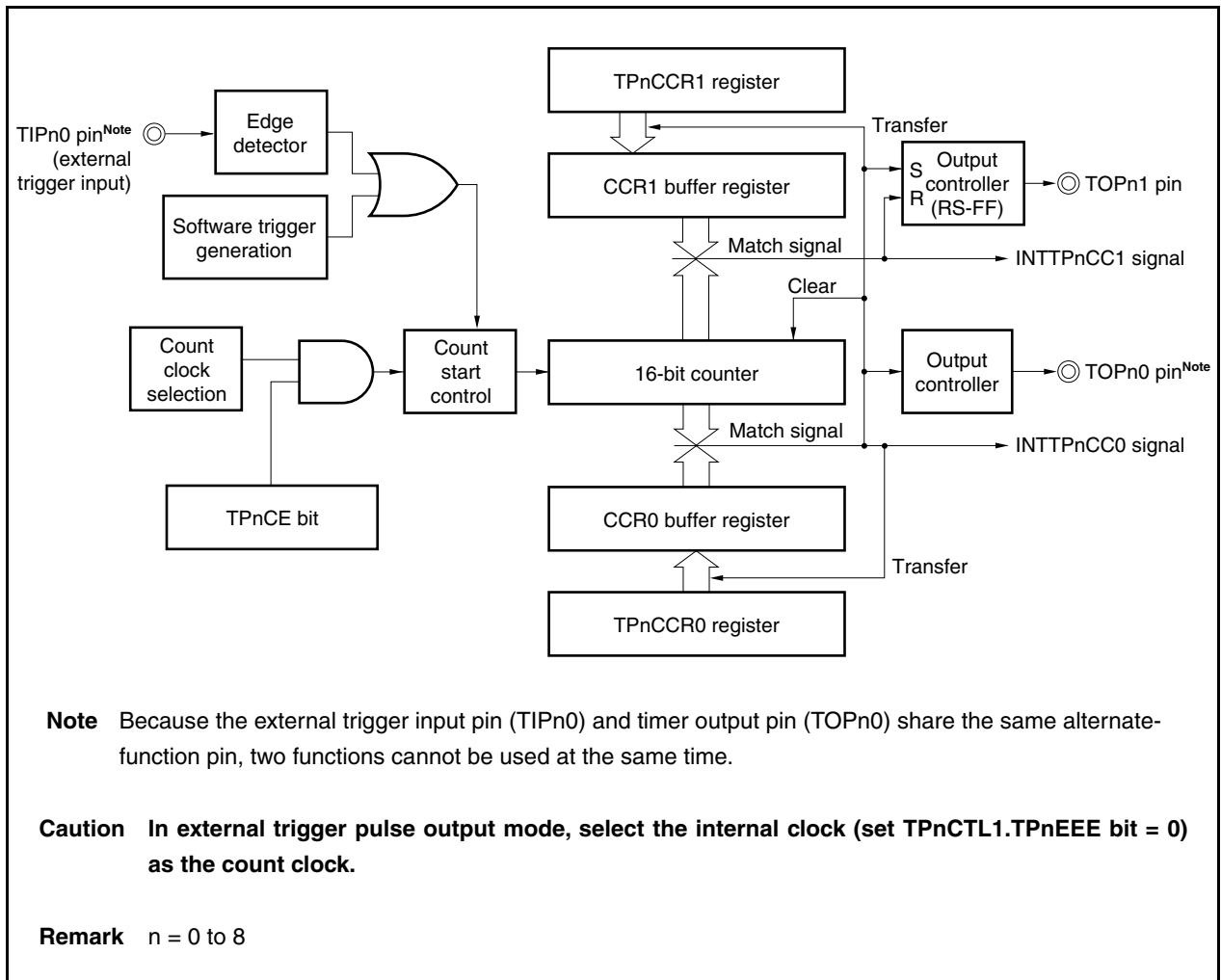
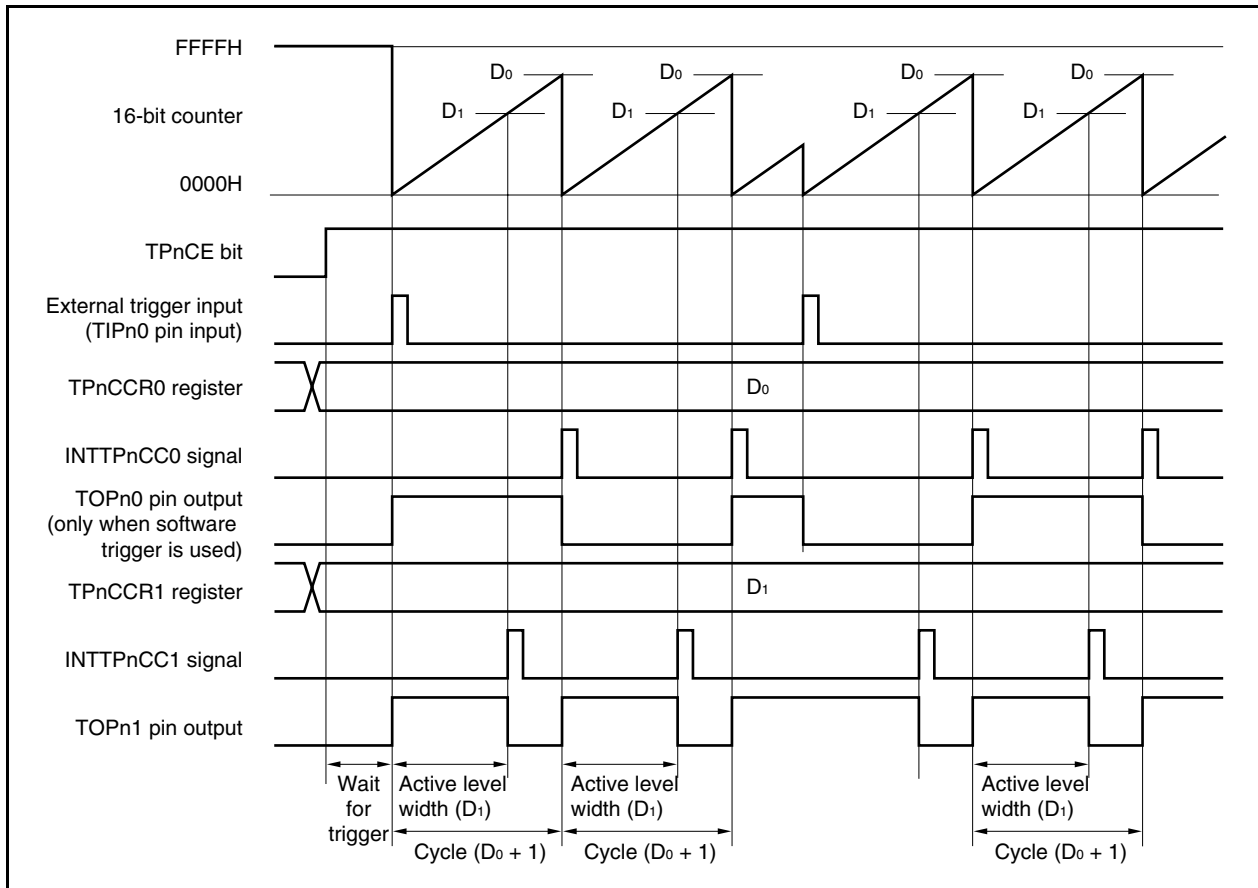

Figure 7-23. Basic Timing in External Trigger Pulse Output Mode



16-bit timer/event counter P waits for a trigger when the TPnCE bit is set to 1. When the trigger is generated, the 16-bit counter is cleared from FFFFH to 0000H, starts counting at the same time, and outputs a PWM waveform from the TOPn1 pin. If the trigger is generated again while the counter is operating, the counter is cleared to 0000H and restarted. (The output of the TOPn0 pin is inverted. The TOPn1 pin outputs a high-level regardless of the status (high/low) when a trigger occurs.)

The active level width, cycle, and duty factor of the PWM waveform can be calculated as follows.

$$\text{Active level width} = (\text{Set value of TPnCCR1 register}) \times \text{Count clock cycle}$$

$$\text{Cycle} = (\text{Set value of TPnCCR0 register} + 1) \times \text{Count clock cycle}$$

$$\text{Duty factor} = (\text{Set value of TPnCCR1 register}) / (\text{Set value of TPnCCR0 register} + 1)$$

The compare match request signal INTTPnCC0 is generated when the 16-bit counter counts next time after its count value matches the value of the CCR0 buffer register, and the 16-bit counter is cleared to 0000H. The compare match interrupt request signal INTTPnCC1 is generated when the count value of the 16-bit counter matches the value of the CCR1 buffer register.

The value set to the TPnCCRa register is transferred to the CCRa buffer register when the count value of the 16-bit counter matches the value of the CCRa buffer register and the 16-bit counter is cleared to 0000H.

The valid edge of an external trigger input (TIPn0) signal, or setting the software trigger (TPnCTL1.TPnEST bit) to 1 is used as the trigger.

**Remark** n = 0 to 8  
a = 0, 1

Figure 7-24. Setting of Registers in External Trigger Pulse Output Mode (1/2)

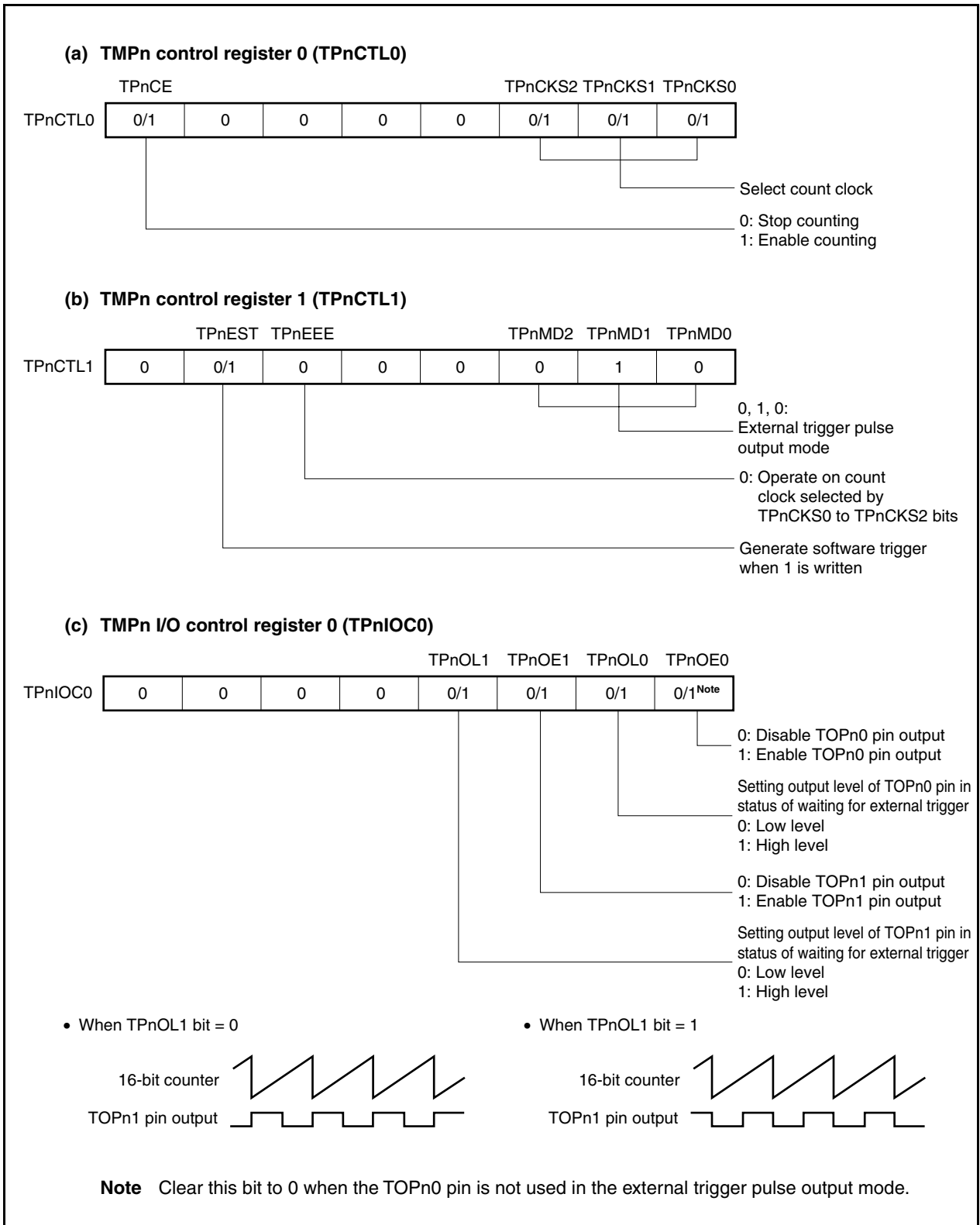
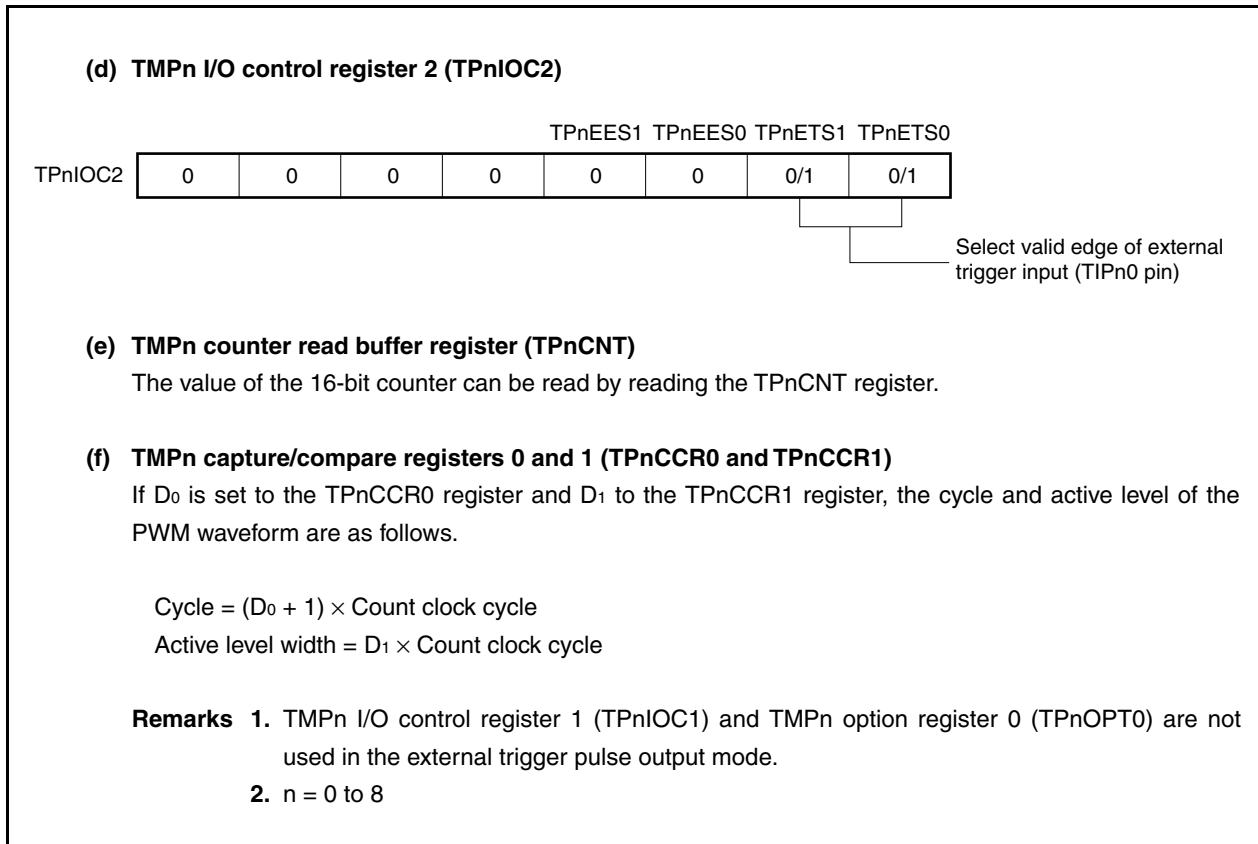

Figure 7-24. Setting of Registers in External Trigger Pulse Output Mode (2/2)



(1) Operation flow in external trigger pulse output mode

Figure 7-25. Software Processing Flow in External Trigger Pulse Output Mode (1/2)

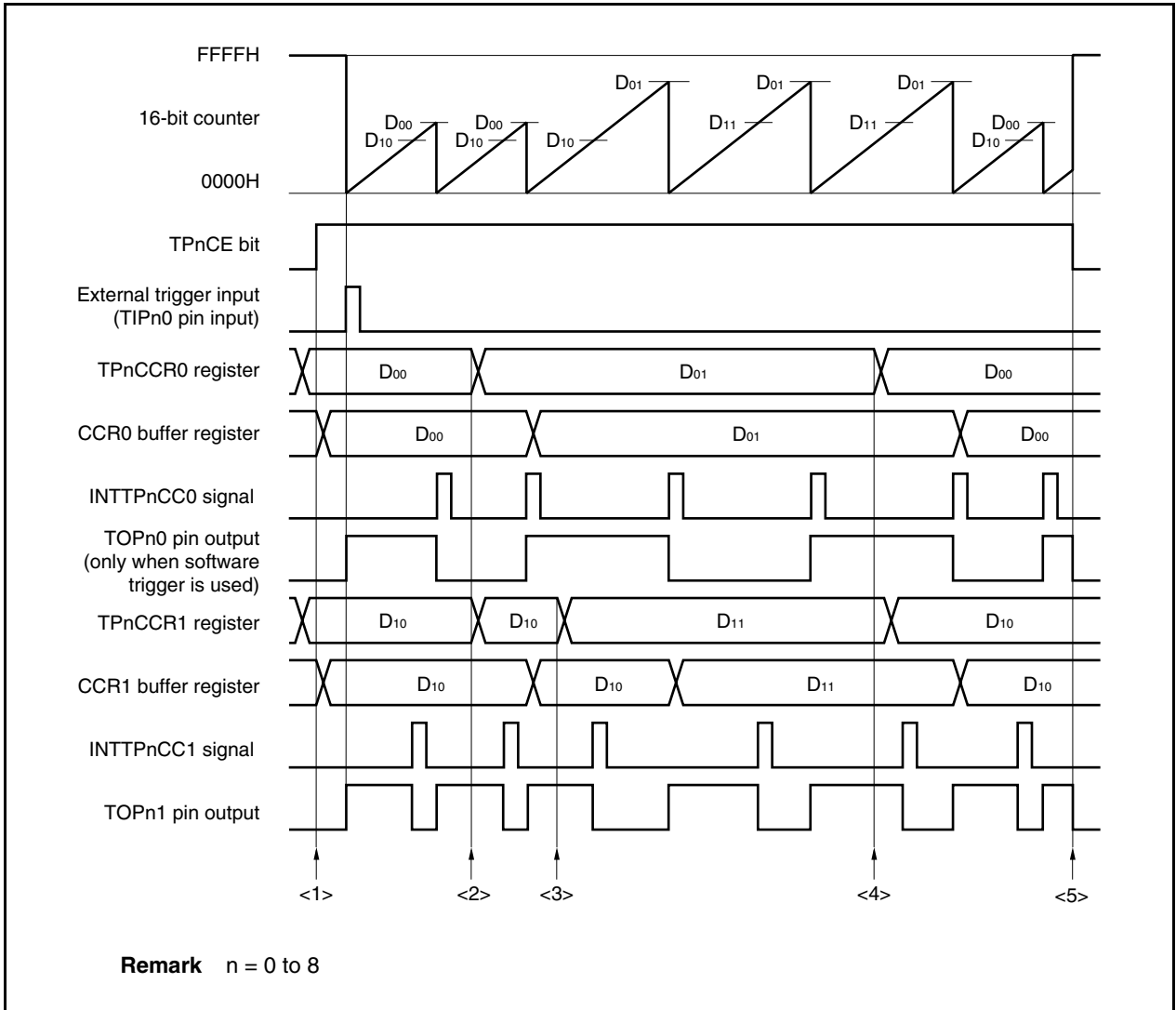
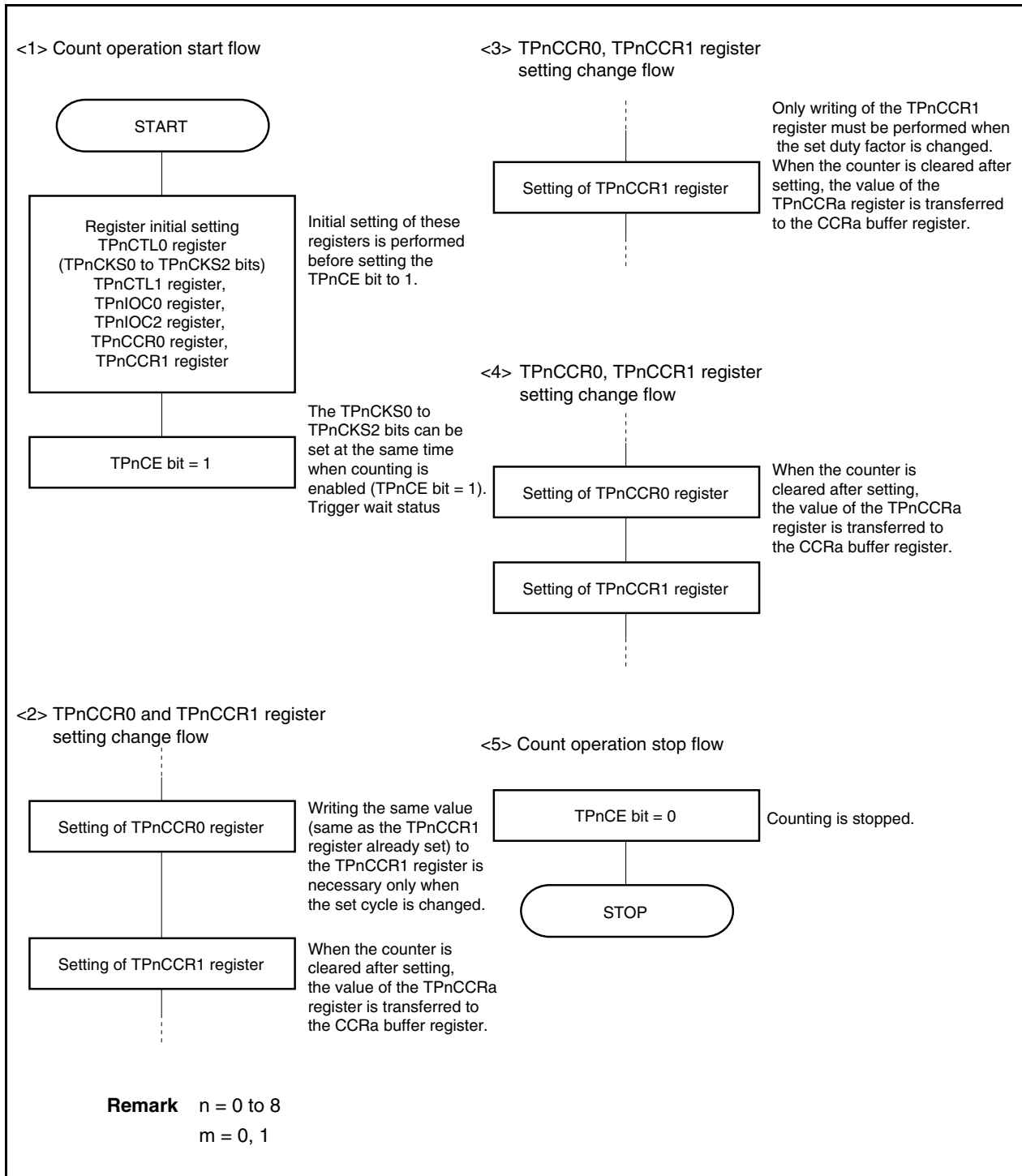

Figure 7-25. Software Processing Flow in External Trigger Pulse Output Mode (2/2)





(2) External trigger pulse output mode operation timing

(a) Note on changing pulse width during operation

To change the PWM waveform while the counter is operating, write the TPnCCR1 register last.

Rewrite the TPnCCRm register after writing the TPnCCR1 register after the INTTPnCC0 signal is detected.

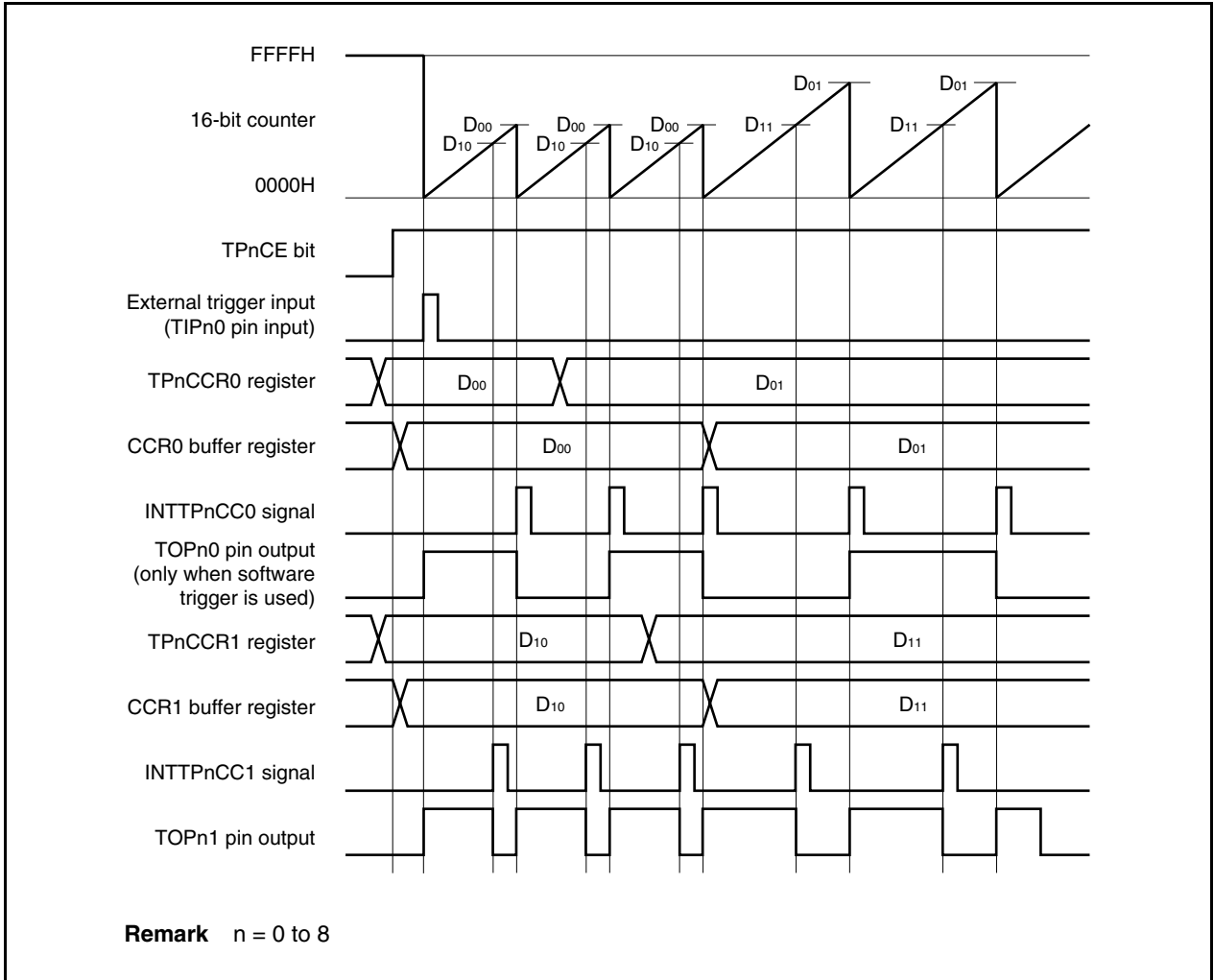

In order to transfer data from the TPnCCRa register to the CCRa buffer register, the TPnCCR1 register must be written.

To change both the cycle and active level width of the PWM waveform at this time, first set the cycle to the TPnCCR0 register and then set the active level width to the TPnCCR1 register.

To change only the cycle of the PWM waveform, first set the cycle to the TPnCCR0 register, and then write the same value (same as the TPnCCR1 register already set) to the TPnCCR1 register.

To change only the active level width (duty factor) of the PWM waveform, only the TPnCCR1 register has to be set.

After data is written to the TPnCCR1 register, the value written to the TPnCCRa register is transferred to the CCRa buffer register in synchronization with clearing of the 16-bit counter, and is used as the value compared with the 16-bit counter.

To write the TPnCCR0 or TPnCCR1 register again after writing the TPnCCR1 register once, do so after the INTTPnCC0 signal is generated. Otherwise, the value of the CCRa buffer register may become undefined because the timing of transferring data from the TPnCCRa register to the CCRa buffer register conflicts with writing the TPnCCRa register.

**Remark** n = 0 to 8

a = 0, 1

**(b) 0%/100% output of PWM waveform**

To output a 0% waveform, set the TPnCCR1 register to 0000H. The 16-bit counter is cleared to 0000H and the INTTPnCC0 and INTTPnCC1 signals are generated at the next timing after a match between the count value of the 16-bit counter and the value of the CCR0 buffer register.

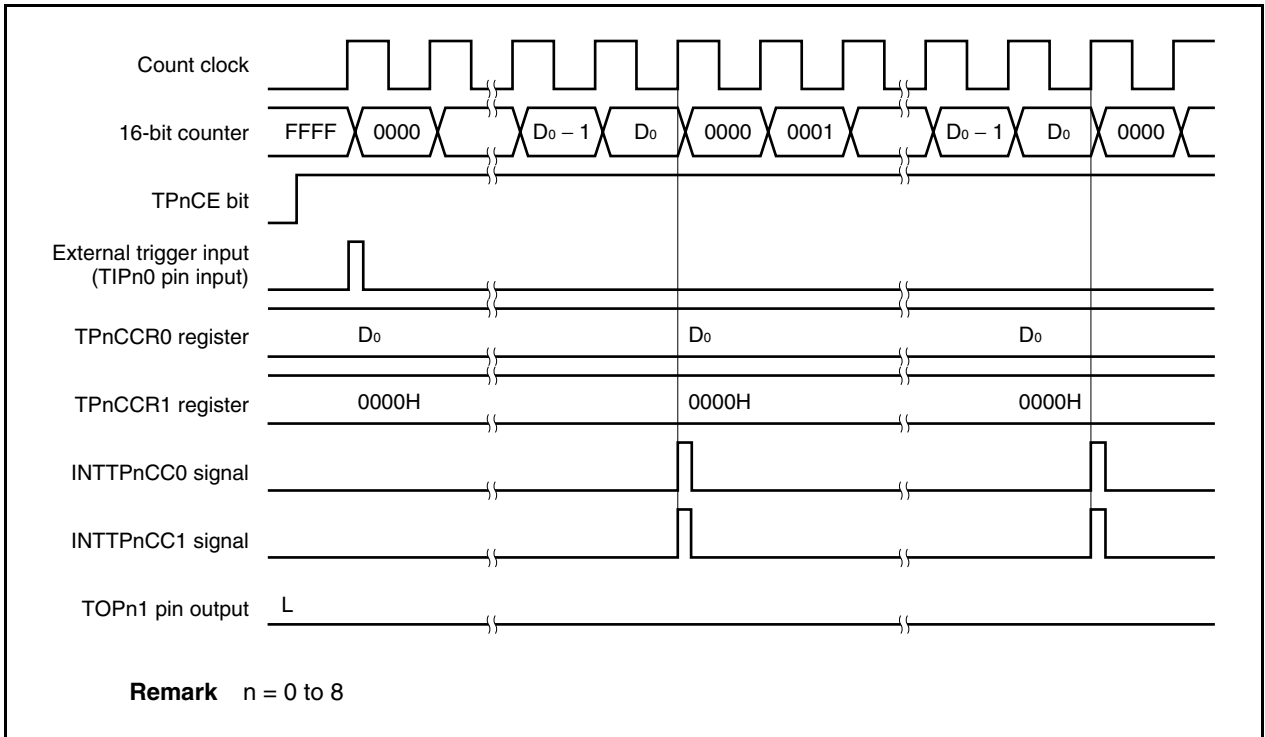

To output a 100% waveform, set a value of (set value of TPnCCR0 register + 1) to the TPnCCR1 register. If the set value of the TPnCCR0 register is FFFFH, 100% output cannot be produced.

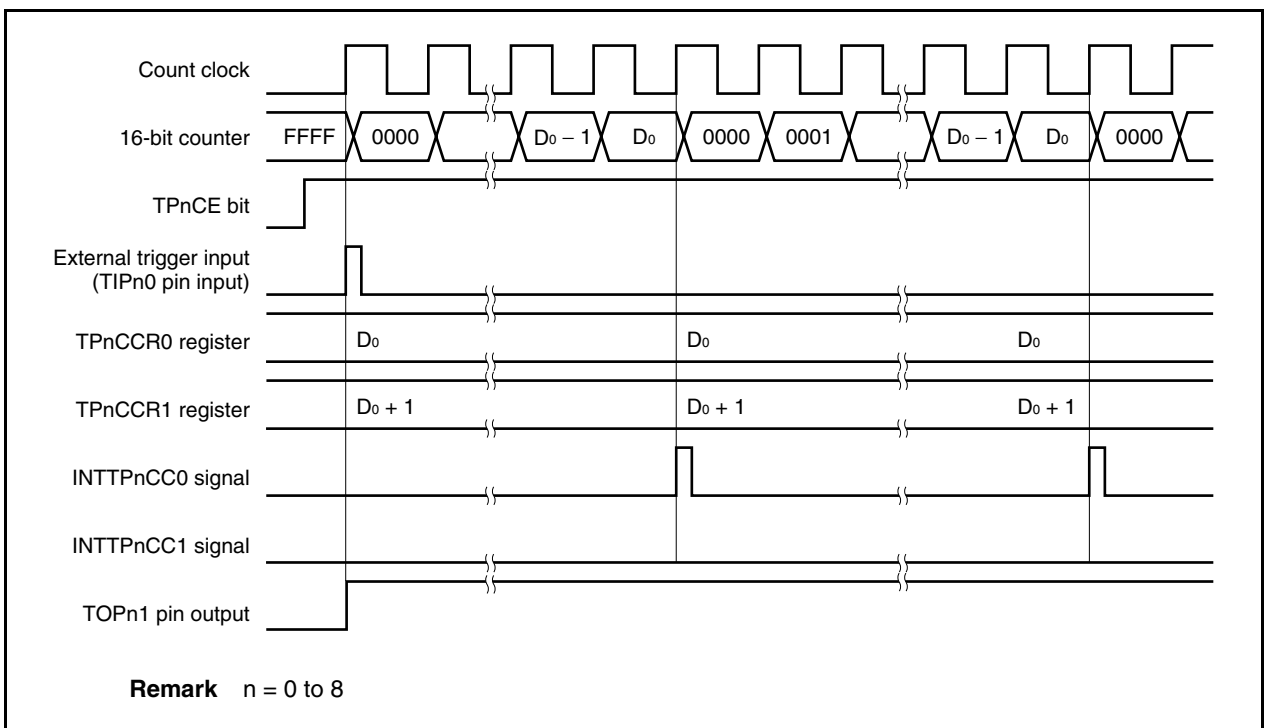

**(c) Conflict between trigger detection and match with CCR1 buffer register**

If the trigger is detected immediately after the INTTPnCC1 signal is generated, the 16-bit counter is immediately cleared to 0000H, the output signal of the TOPn1 pin is asserted, and the counter continues counting. Consequently, the inactive period of the PWM waveform is shortened.

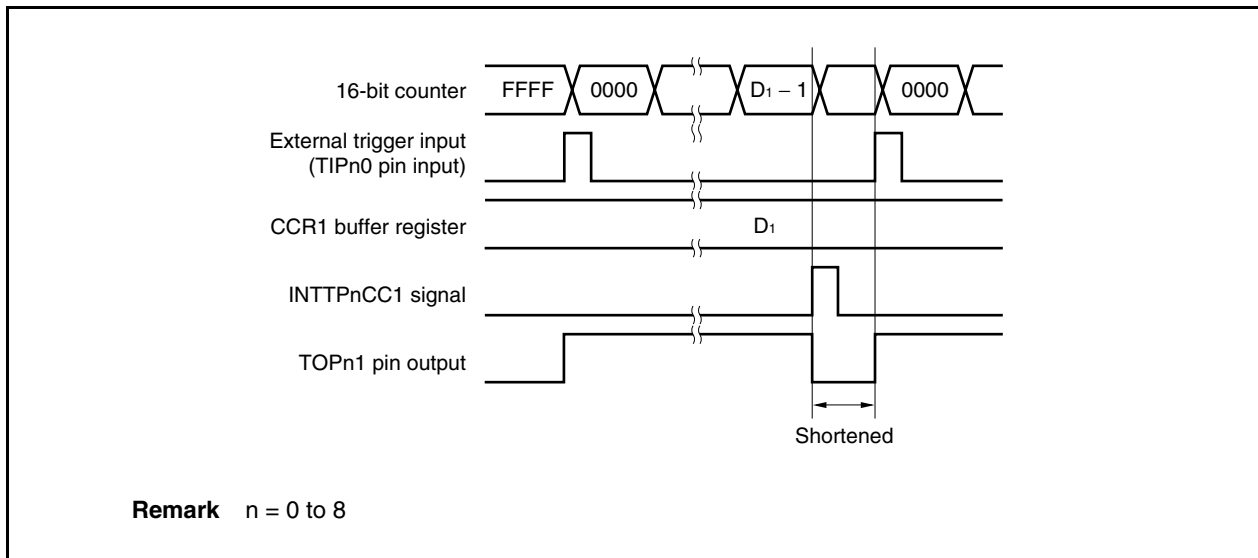

If the trigger is detected immediately before the INTTPnCC1 signal is generated, the INTTPnCC1 signal is not generated, and the 16-bit counter is cleared to 0000H and continues counting. The output signal of the TOPn1 pin remains active. Consequently, the active period of the PWM waveform is extended.

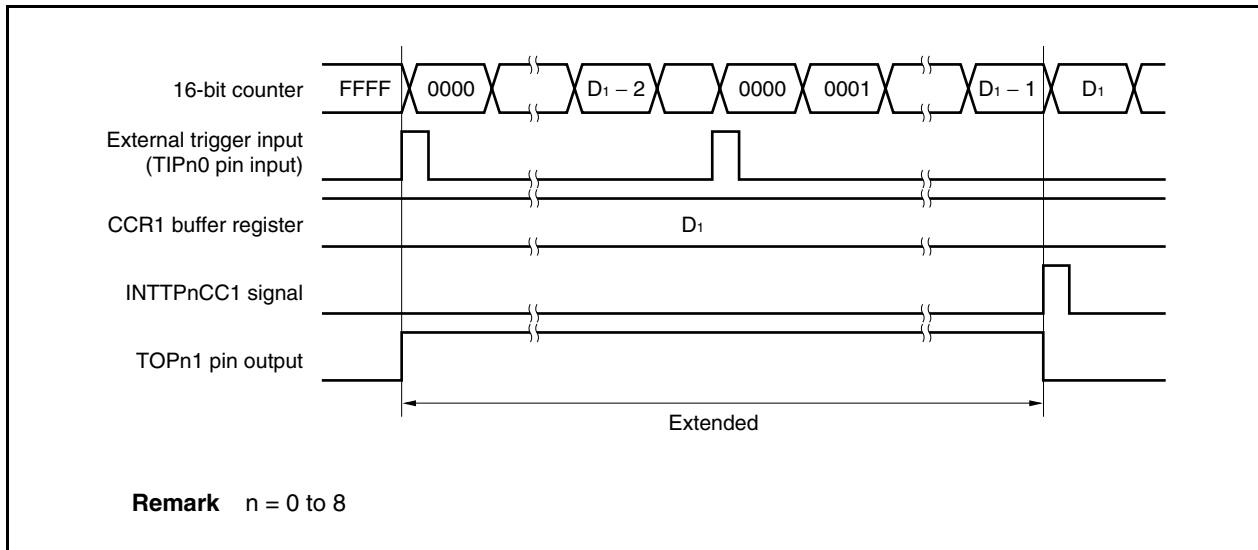

**(d) Conflict between trigger detection and match with CCR0 buffer register**

If the trigger is detected immediately after the INTTPnCC0 signal is generated, the 16-bit counter is cleared to 0000H and continues counting up. Therefore, the active period of the TOPn1 pin is extended by time from generation of the INTTPnCC0 signal to trigger detection.

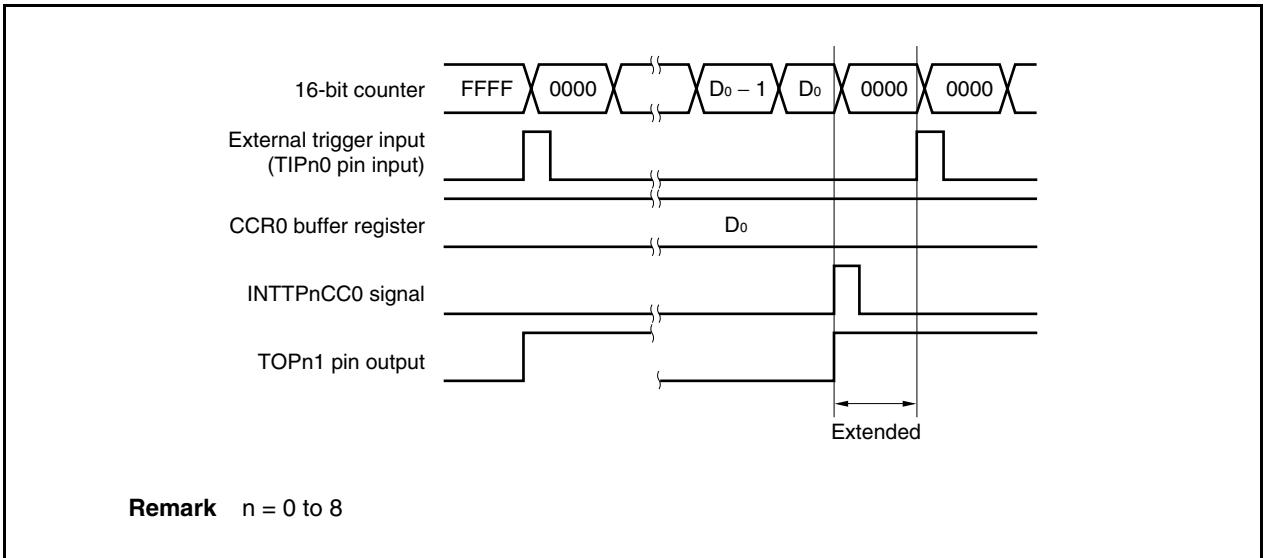

If the trigger is detected immediately before the INTTPnCC0 signal is generated, the INTTPnCC0 signal is not generated. The 16-bit counter is cleared to 0000H, the TOPn1 pin is asserted, and the counter continues counting. Consequently, the inactive period of the PWM waveform is shortened.

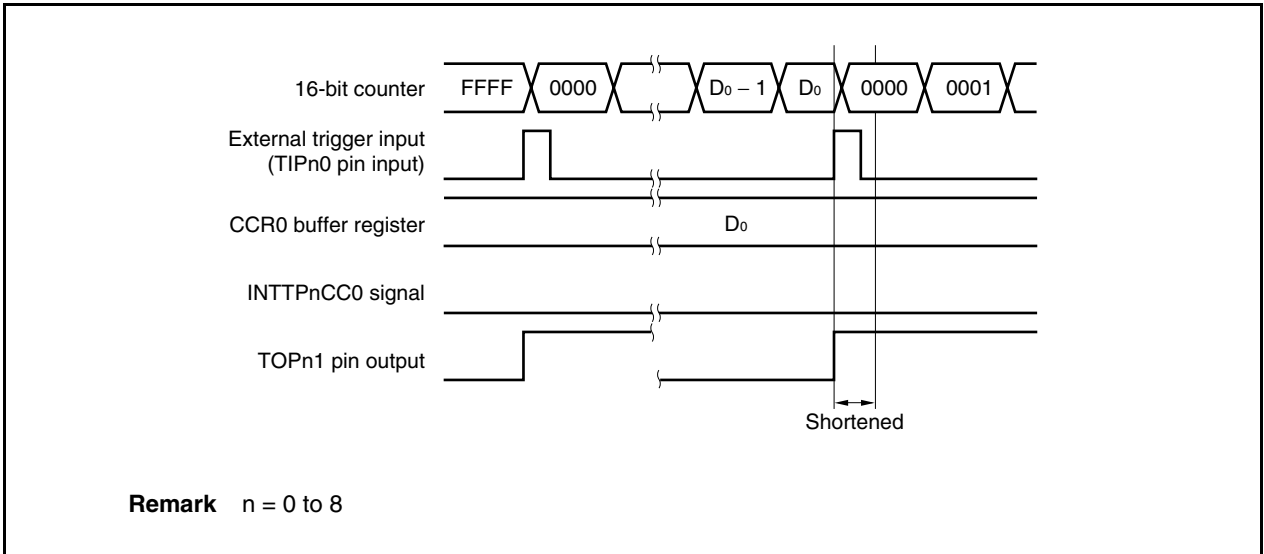

**(e) Generation timing of compare match interrupt request signal (INTTPnCC1)**

The timing of generation of the INTTPnCC1 signal in the external trigger pulse output mode differs from the timing of other mode INTTPnCC1 signals; the INTTPnCC1 signal is generated when the count value of the 16-bit counter matches the value of the TPnCCR1 register.

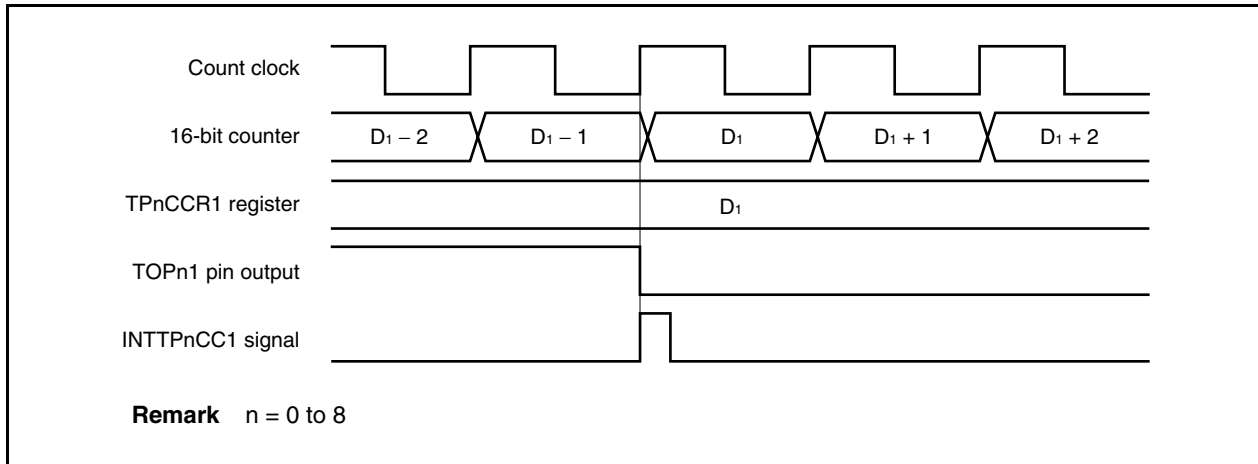

Usually, the INTTPnCC1 signal is generated in synchronization with the next count up, after the count value of the 16-bit counter matches the value of the TPnCCR1 register.

In the external trigger pulse output mode, however, it is generated one clock earlier. This is because the timing is changed to match the timing of changing the output signal of the TOPn1 pin.

**7.6.4 One-shot pulse output mode (TPnMD2 to TPnMD0 bits = 011)**

In the one-shot pulse output mode, 16-bit timer/event counter P waits for a trigger when the TPnCTL0.TPnCE bit is set to 1. When the valid edge of an external trigger input (TIPn0) is detected, 16-bit timer/event counter P starts counting, and outputs a one-shot pulse from the TOPn1 pin.

Instead of the external trigger (TIPn0), a software trigger can also be generated to output the pulse. When the software trigger is used, the TOPn0 pin outputs the active level while the 16-bit counter is counting, and the inactive level when the counter is stopped (waiting for a trigger).

**Figure 7-26. Configuration in One-Shot Pulse Output Mode**

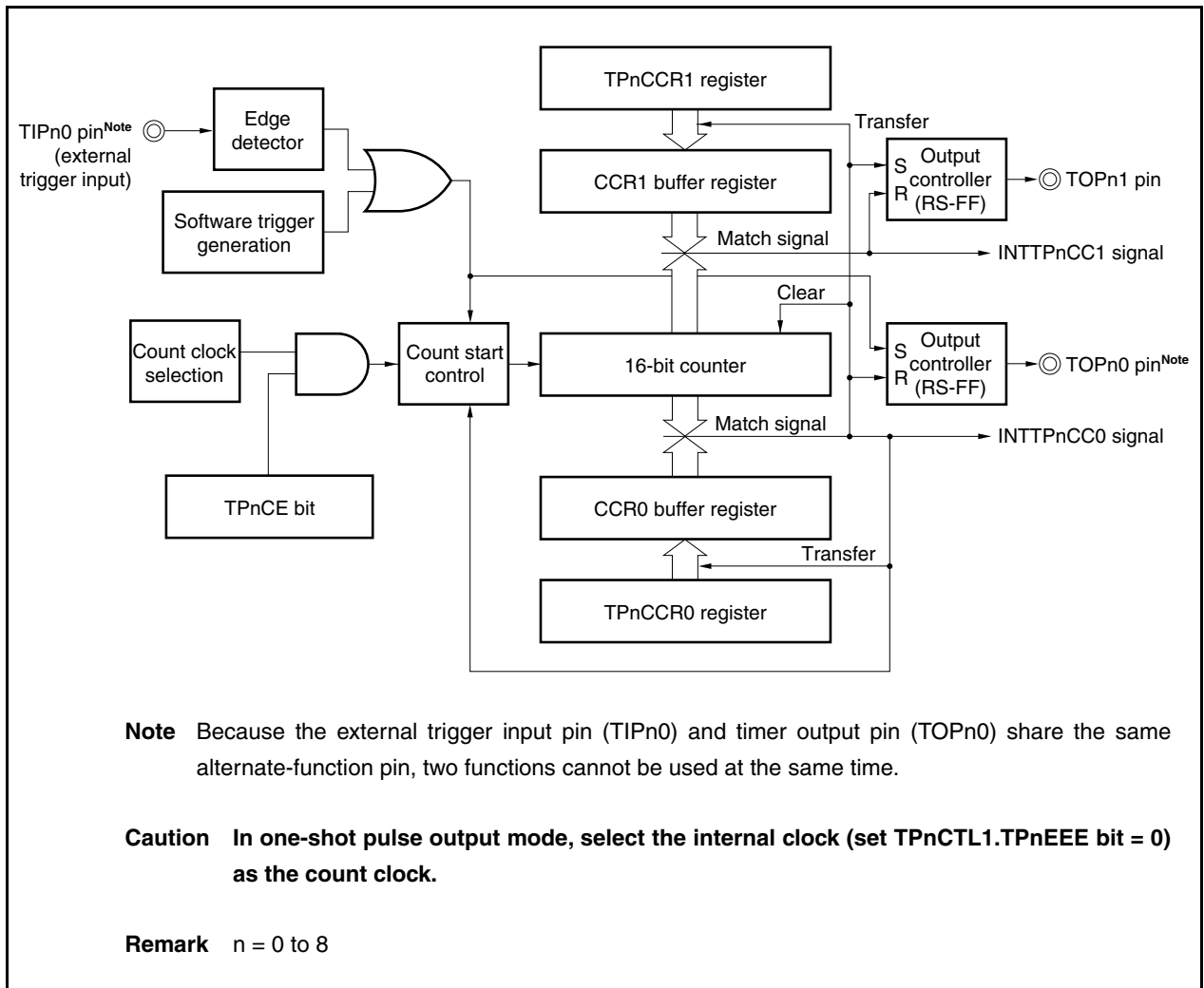
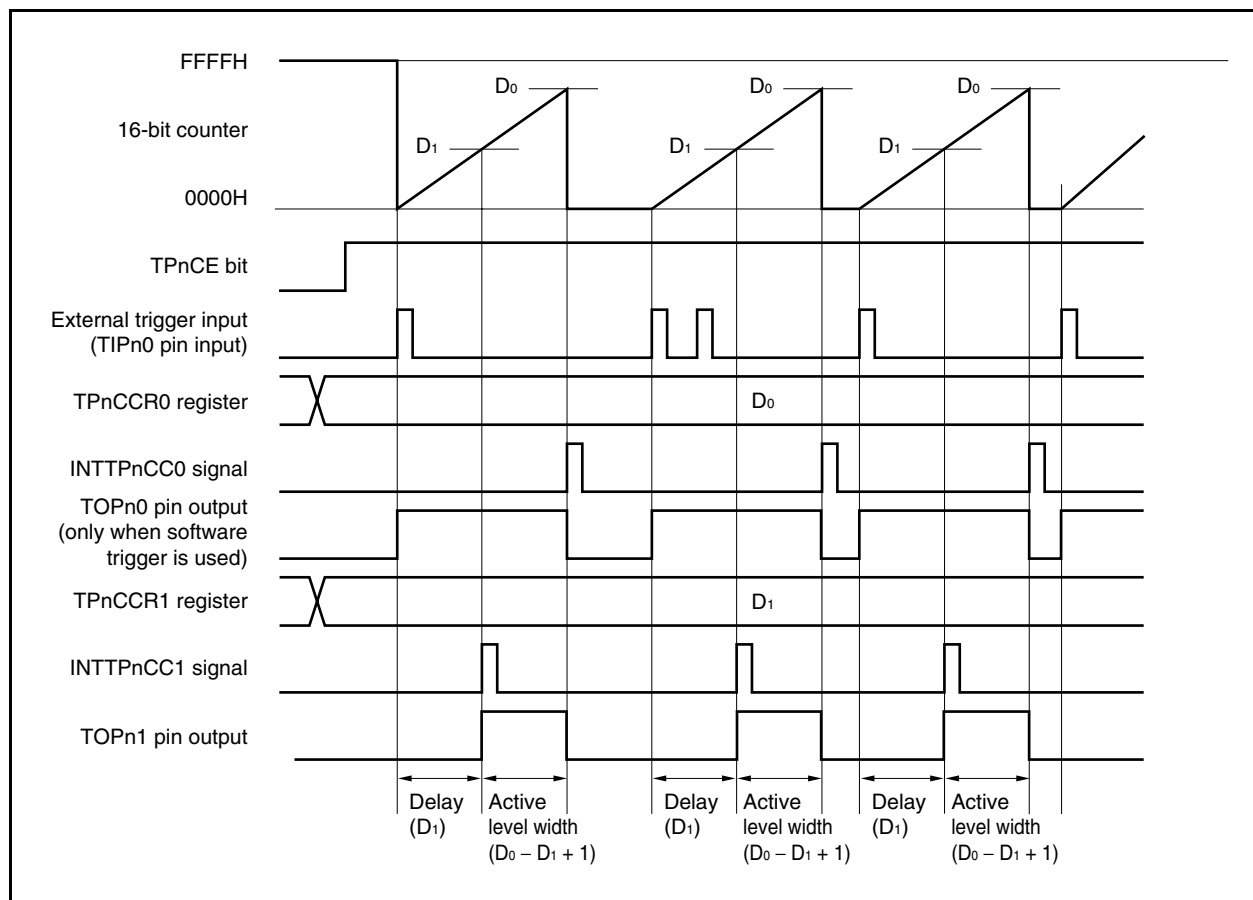

Figure 7-27. Basic Timing in One-Shot Pulse Output Mode



When the TPnCE bit is set to 1, 16-bit timer/event counter P waits for a trigger. When the trigger is generated, the 16-bit counter is cleared from FFFFH to 0000H, starts counting, and outputs a one-shot pulse from the TOPn1 pin. After the one-shot pulse is output, the 16-bit counter is set to 0000H, stops counting, and waits for a trigger. When the trigger is generated again, the 16-bit counter starts counting from 0000H. Generations of a trigger is ignored while the one-shot pulse is being output.

The output delay period and active level width of the one-shot pulse can be calculated as follows.

$$\text{Output delay period} = (\text{Set value of TPNCCR1 register}) \times \text{Count clock cycle}$$

$$\text{Active level width} = (\text{Set value of TPNCCR0 register} - \text{Set value of TPNCCR1 register} + 1) \times \text{Count clock cycle}$$

The compare match interrupt request signal INTTPnCC0 is generated when the 16-bit counter counts after its count value matches the value of the CCR0 buffer register. The compare match interrupt request signal INTTPnCC1 is generated when the count value of the 16-bit counter matches the value of the CCR1 buffer register.

The valid edge of an external trigger input (TIPn0 pin) or setting the software trigger (TPnCTL1.TPnEST bit) to 1 is used as the trigger.

**Remark** n = 0 to 8



Figure 7-28. Setting of Registers in One-Shot Pulse Output Mode (1/2)

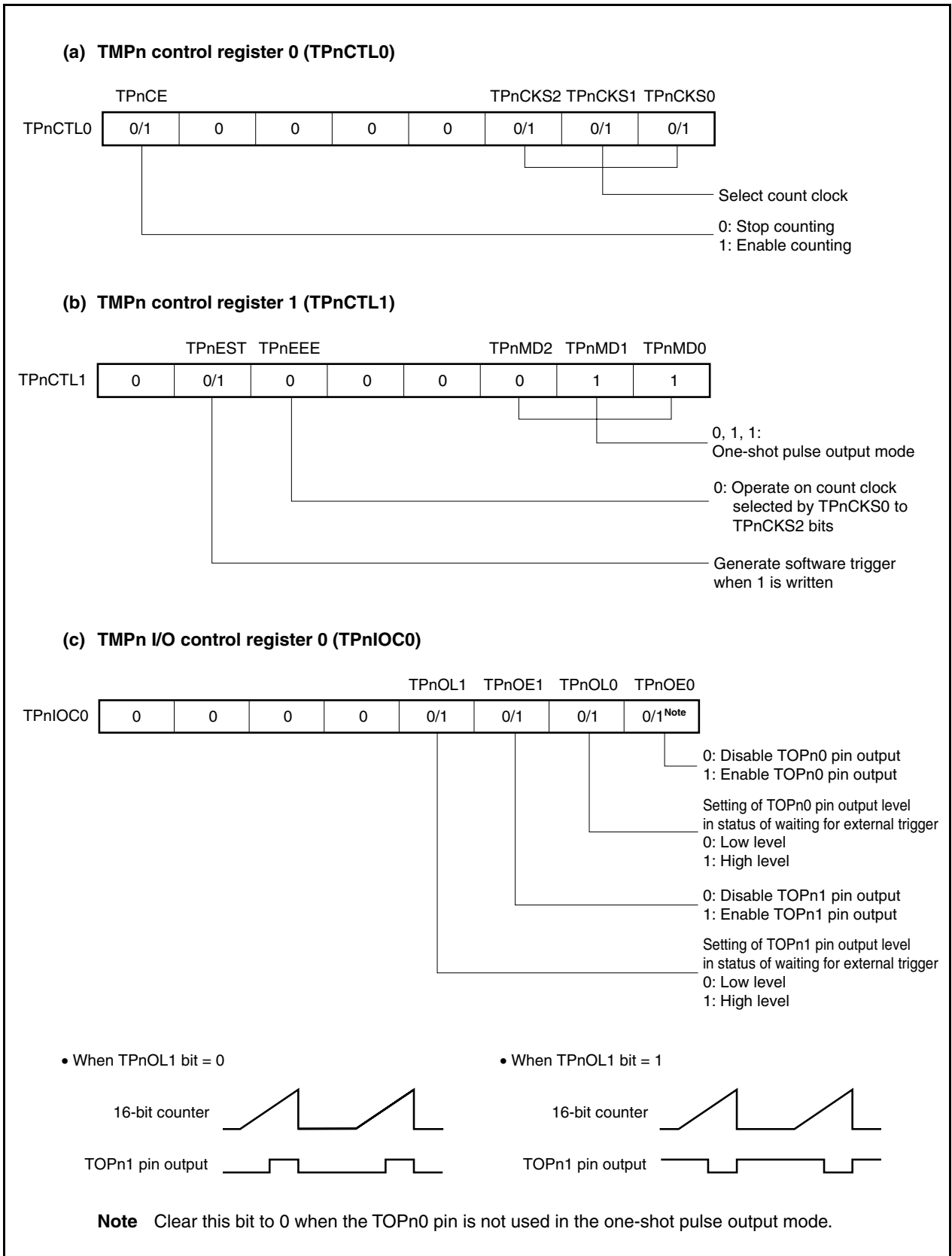
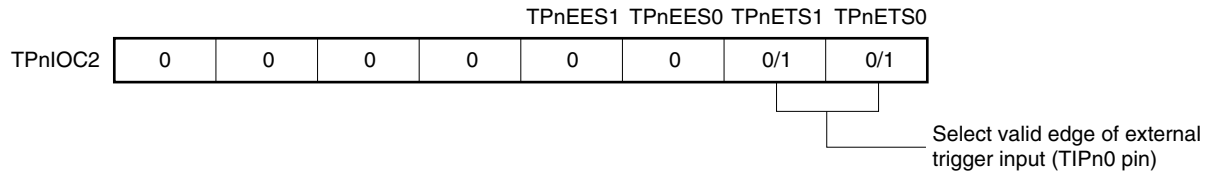

Figure 7-28. Setting of Registers in One-Shot Pulse Output Mode (2/2)

## (d) TMPn I/O control register 2 (TPnIOC2)



## (e) TMPn counter read buffer register (TPnCNT)

The value of the 16-bit counter can be read by reading the TPnCNT register.

## (f) TMPn capture/compare registers 0 and 1 (TPnCCR0 and TPnCCR1)

If  $D_0$  is set to the TPnCCR0 register and  $D_1$  to the TPnCCR1 register, the active level width and output delay period of the one-shot pulse are as follows.

Active level width =  $(D_0 - D_1 + 1) \times$  Count clock cycle

Output delay period =  $(D_1) \times$  Count clock cycle

**Caution** One-shot pulses are not output even in the one-shot pulse output mode, if the value set in the TPnCCR1 register is greater than that set in the TPnCCR0 register.

**Remarks** 1. TMPn I/O control register 1 (TPnIOC1) and TMPn option register 0 (TPnOPT0) are not used in the one-shot pulse output mode.

2.  $n = 0$  to 8

(1) Operation flow in one-shot pulse output mode

Figure 7-29. Software Processing Flow in One-Shot Pulse Output Mode

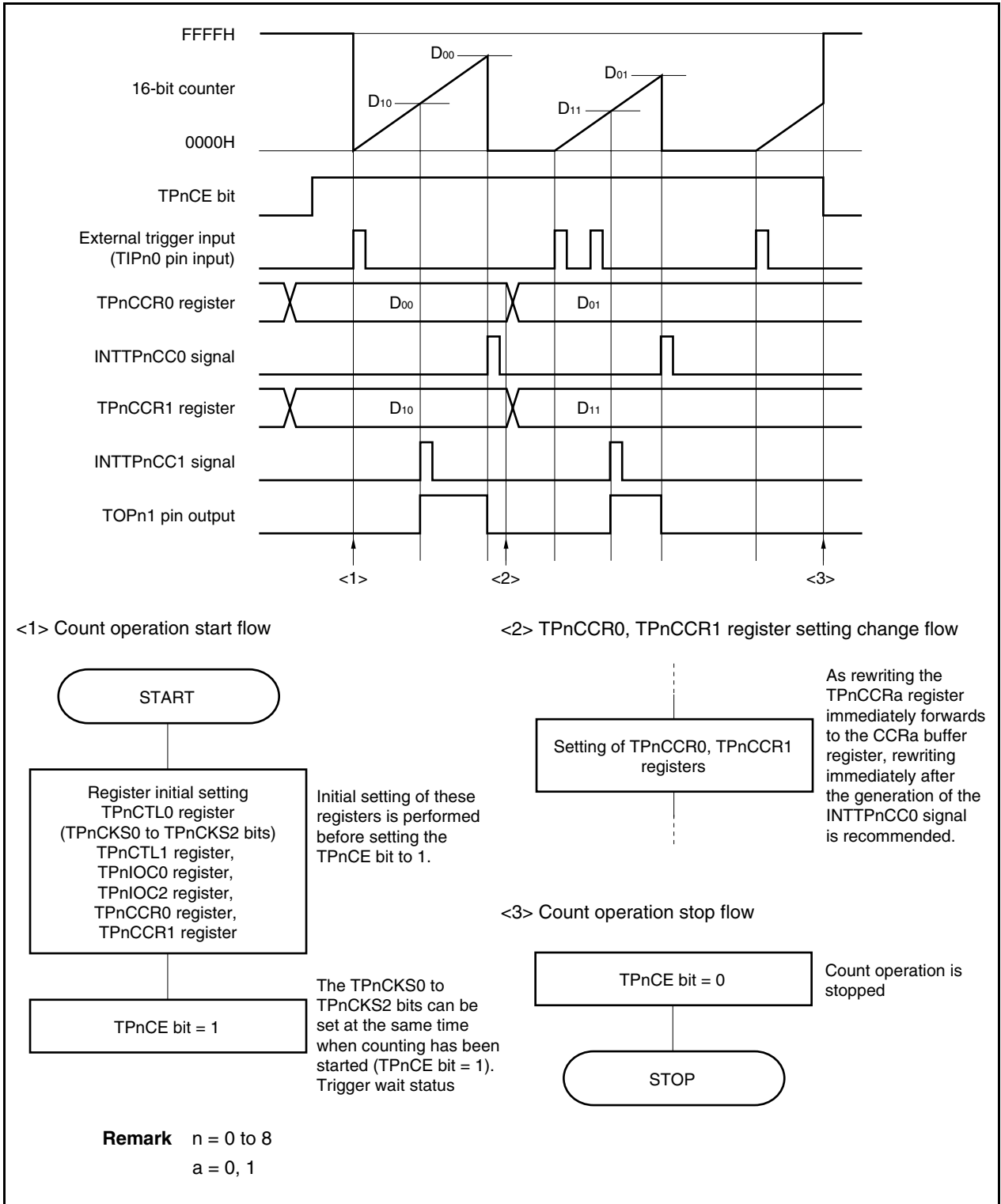

(2) Operation timing in one-shot pulse output mode

(a) Note on rewriting TPnCCRa register

If the value of the TPnCCRa register is rewritten to a smaller value during counting, the 16-bit counter may overflow. If there is a possibility of overflow, stop counting and then change the set value.

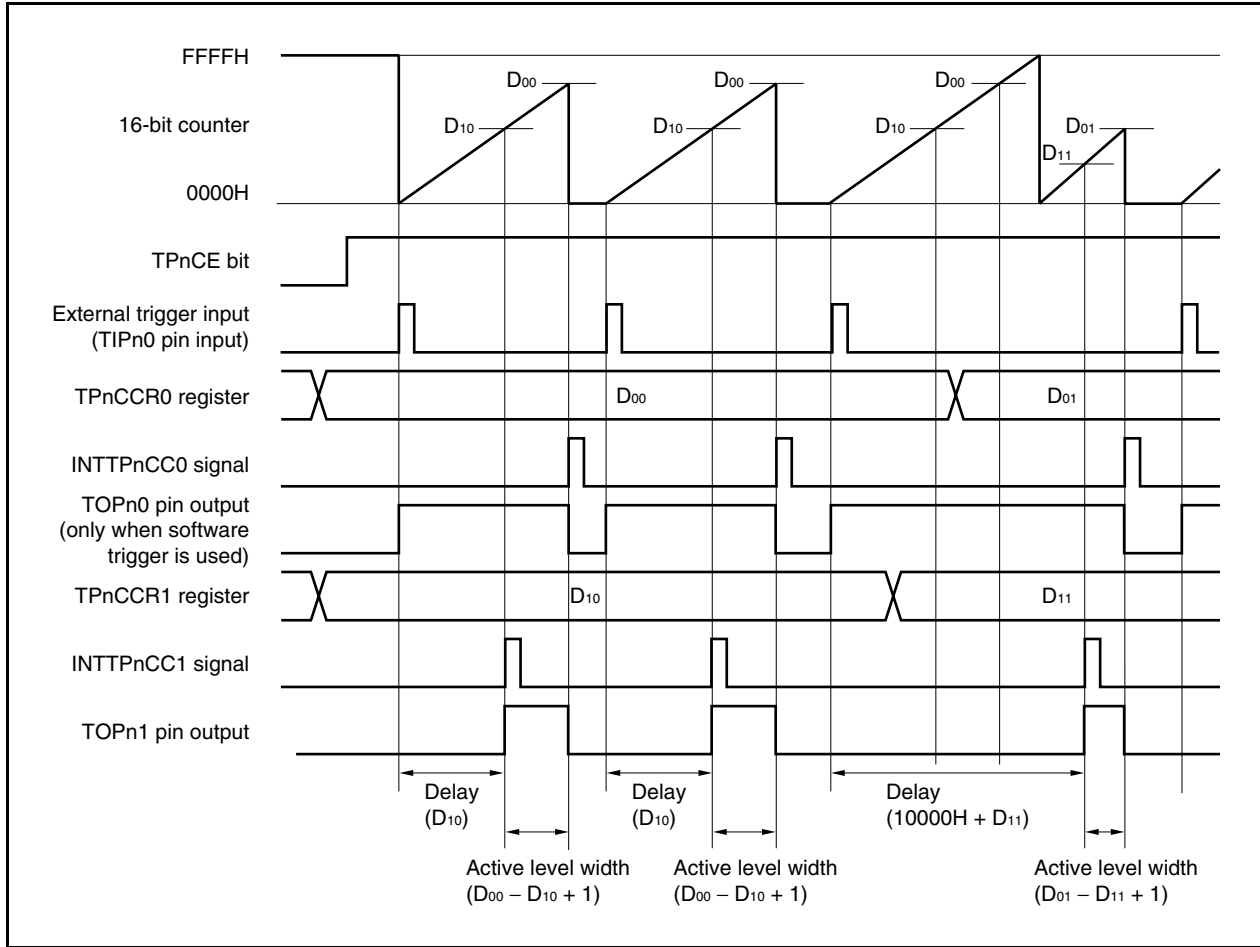

When the TPnCCR0 register is rewritten from D<sub>00</sub> to D<sub>01</sub> and the TPnCCR1 register from D<sub>10</sub> to D<sub>11</sub> where D<sub>00</sub> > D<sub>01</sub> and D<sub>10</sub> > D<sub>11</sub>, if the TPnCCR1 register is rewritten when the count value of the 16-bit counter is greater than D<sub>11</sub> and less than D<sub>10</sub> and if the TPnCCR0 register is rewritten when the count value is greater than D<sub>01</sub> and less than D<sub>00</sub>, each set value is reflected as soon as the register has been rewritten and compared with the count value. The counter counts up to FFFFH and then counts up again from 0000H. When the count value matches D<sub>11</sub>, the counter generates the INTTPnCC1 signal and asserts the TOPn1 pin. When the count value matches D<sub>01</sub>, the counter generates the INTTPnCC0 signal, deasserts the TOPn1 pin, and stops counting.

Therefore, the counter may output a pulse with a delay period or active period different from that of the one-shot pulse that is originally expected.

**Remark** n = 0 to 8  
a = 0, 1

**(b) Generation timing of compare match interrupt request signal (INTTPnCC1)**

The generation timing of the INTTPnCC1 signal in the one-shot pulse output mode is different from other mode INTTPnCC1 signals; the INTTPnCC1 signal is generated when the count value of the 16-bit counter matches the value of the TPnCCR1 register.

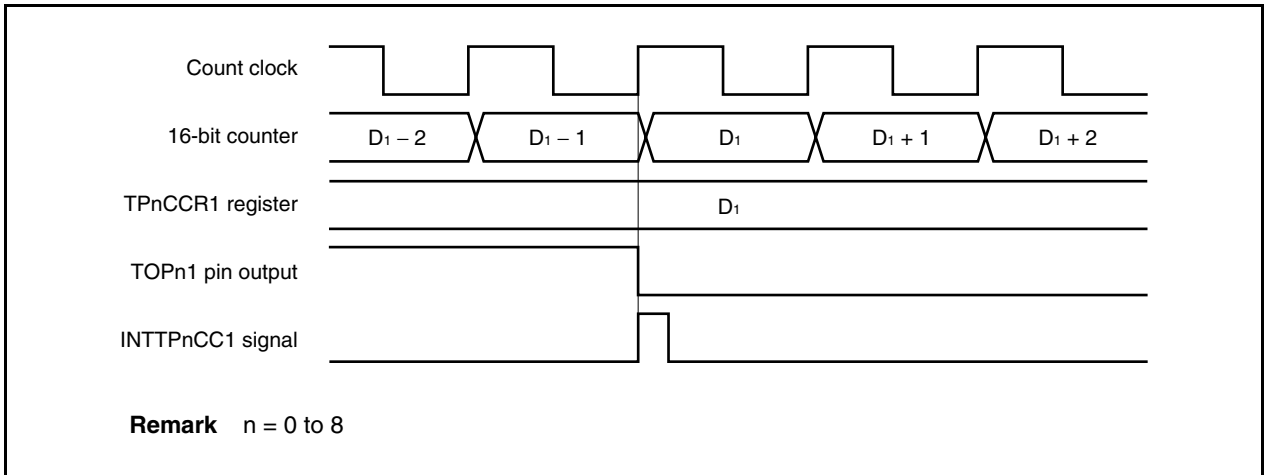

Usually, the INTTPnCC1 signal is generated when the 16-bit counter counts up next time after its count value matches the value of the TPnCCR1 register.

In the one-shot pulse output mode, however, it is generated one clock earlier. This is because the timing is changed to match the change timing of the TOPn1 pin.

**Remark**  $n = 0$  to 8

### 7.6.5 PWM output mode (TPnMD2 to TPnMD0 bits = 100)

In the PWM output mode, a PWM waveform is output from the TOPn1 pin when the TPnCTL0.TPnCE bit is set to 1.

In addition, a square wave with a duty factor of 50% with the set value of the TPnCCR0 register + 1 as half its cycle is output from the TOPn0 pin.

Figure 7-30. Configuration in PWM Output Mode

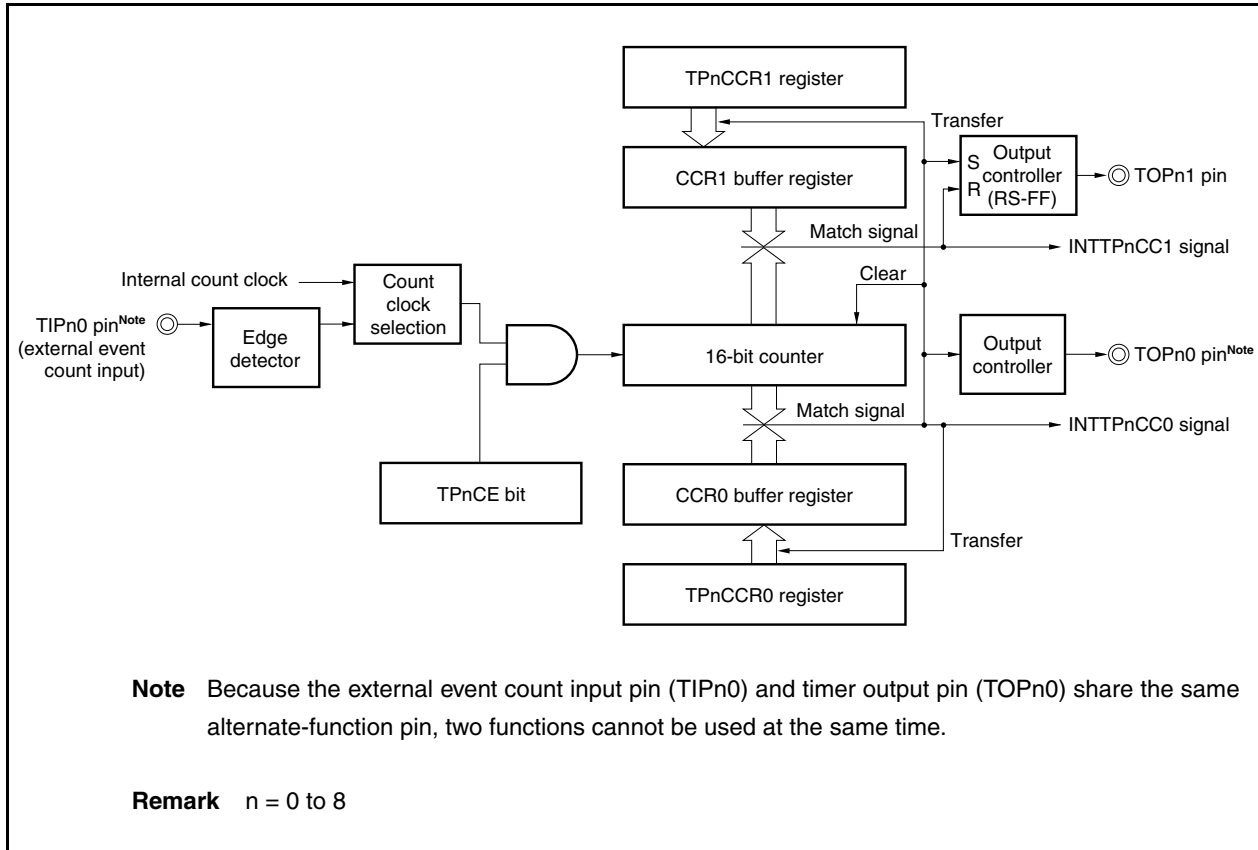
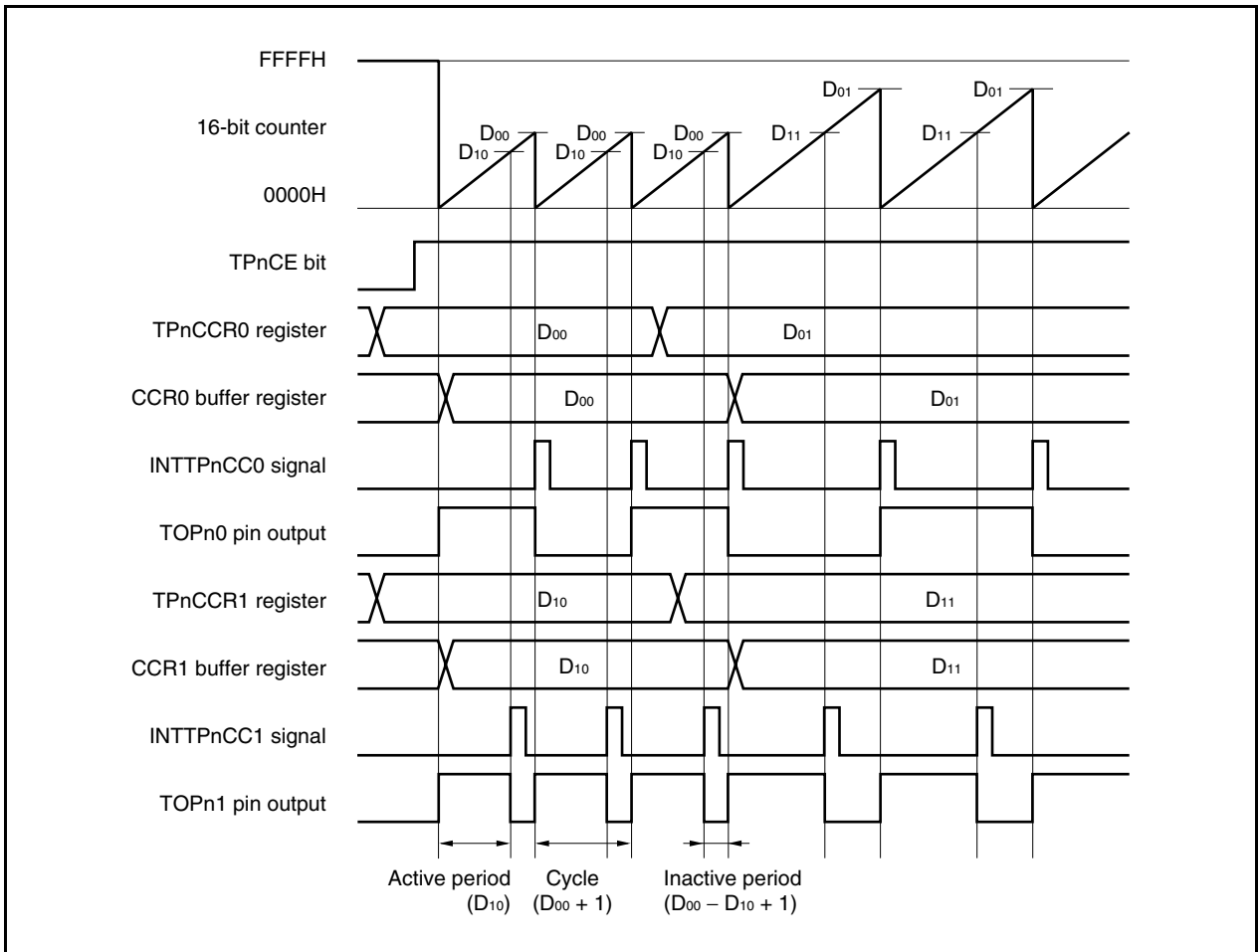

Figure 7-31. Basic Timing in PWM Output Mode



When the TPnCE bit is set to 1, the 16-bit counter is cleared from FFFFH to 0000H, starts counting, and outputs a PWM waveform from the TOPn1 pin.

The active level width, cycle, and duty factor of the PWM waveform can be calculated as follows.

$$\text{Active level width} = (\text{Set value of TPnCCR1 register}) \times \text{Count clock cycle}$$

$$\text{Cycle} = (\text{Set value of TPnCCR0 register} + 1) \times \text{Count clock cycle}$$

$$\text{Duty factor} = (\text{Set value of TPnCCR1 register}) / (\text{Set value of TPnCCR0 register} + 1)$$

The PWM waveform can be changed by rewriting the TPnCCR<sub>a</sub> register while the counter is operating. The newly written value is reflected when the count value of the 16-bit counter matches the value of the CCR0 buffer register and the 16-bit counter is cleared to 0000H.

The compare match interrupt request signal INTTPnCC0 is generated when the 16-bit counter counts next time after its count value matches the value of the CCR0 buffer register, and the 16-bit counter is cleared to 0000H. The compare match interrupt request signal INTTPnCC1 is generated when the count value of the 16-bit counter matches the value of the CCR1 buffer register.

The value set to the TPnCCR<sub>a</sub> register is transferred to the CCR<sub>a</sub> buffer register when the count value of the 16-bit counter matches the value of the CCR<sub>a</sub> buffer register and the 16-bit counter is cleared to 0000H.

**Remark** n = 0 to 8

a = 0, 1

Figure 7-32. Setting of Registers in PWM Output Mode (1/2)

(a) TMPn control register 0 (TPnCTL0)

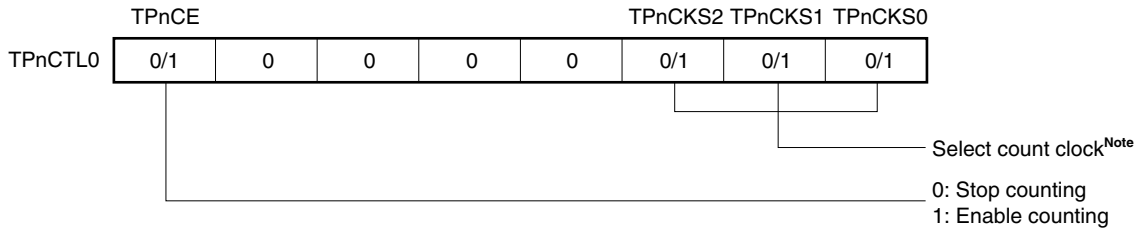

**Note** The setting is invalid when the TPnCTL1.TPnEEE bit = 1.

(b) TMPn control register 1 (TPnCTL1)

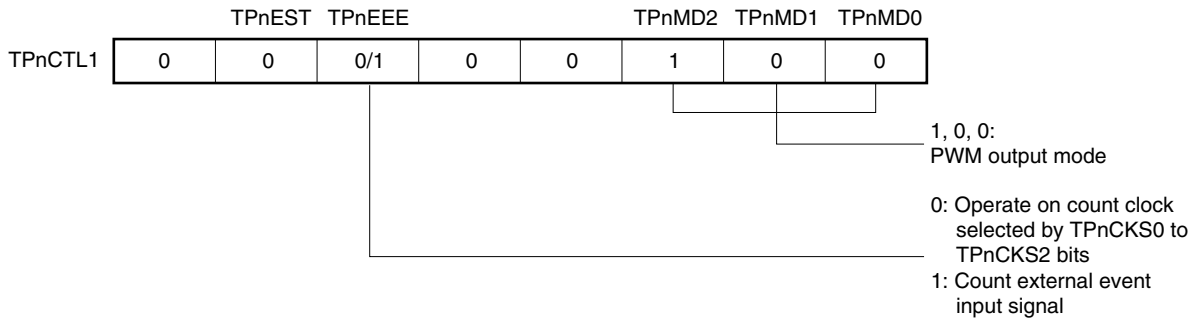

(c) TMPn I/O control register 0 (TPnIOC0)

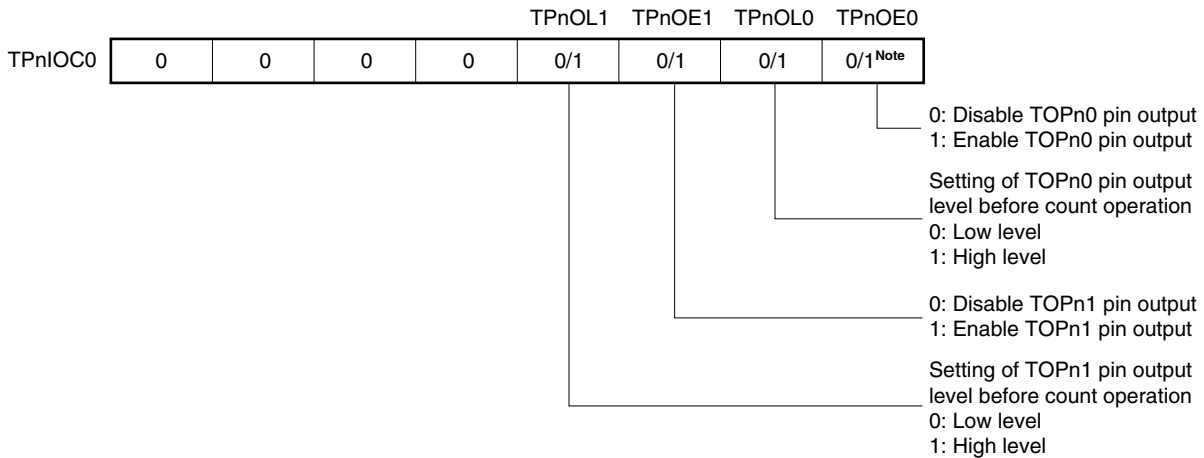

• When TPnOL1 bit = 0

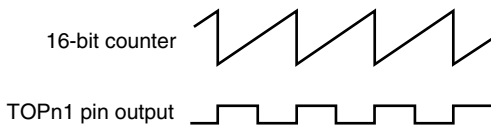

• When TPnOL1 bit = 1

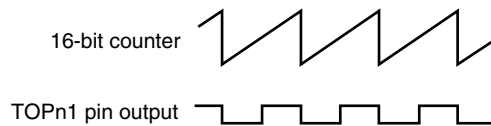

**Note** Clear this bit to 0 when the TOPn0 pin is not used in the PWM output mode.



Figure 7-32. Register Setting in PWM Output Mode (2/2)

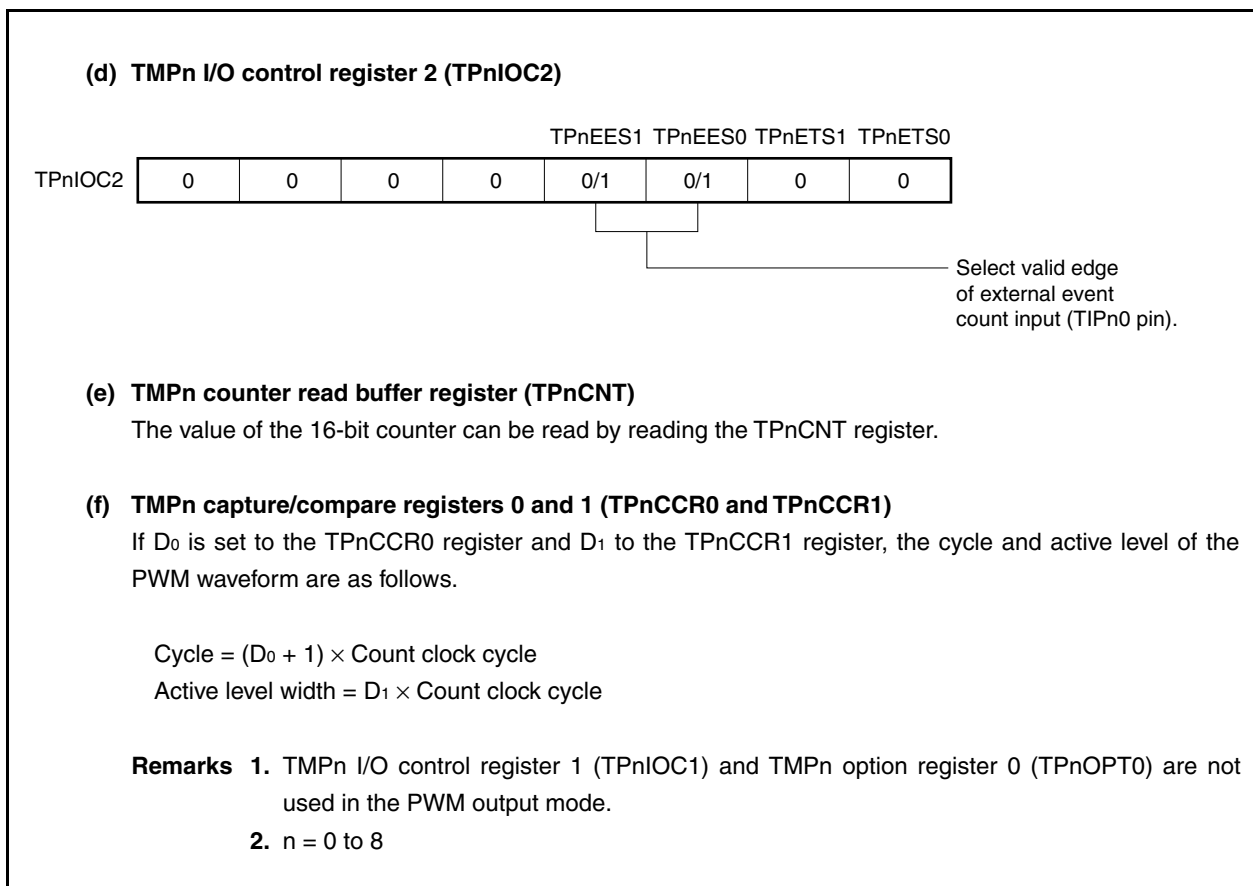

(1) Operation flow in PWM output mode

Figure 7-33. Software Processing Flow in PWM Output Mode (1/2)

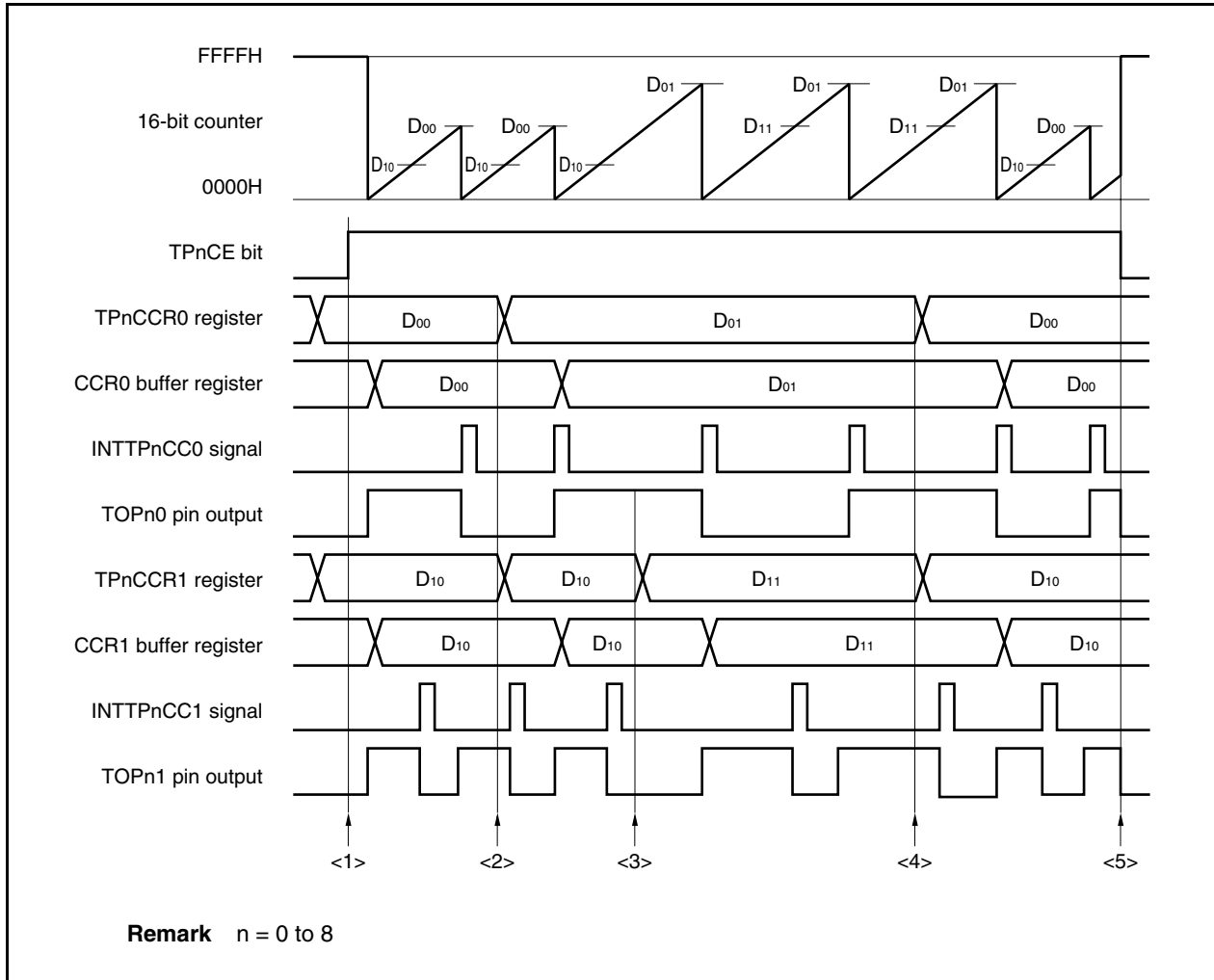
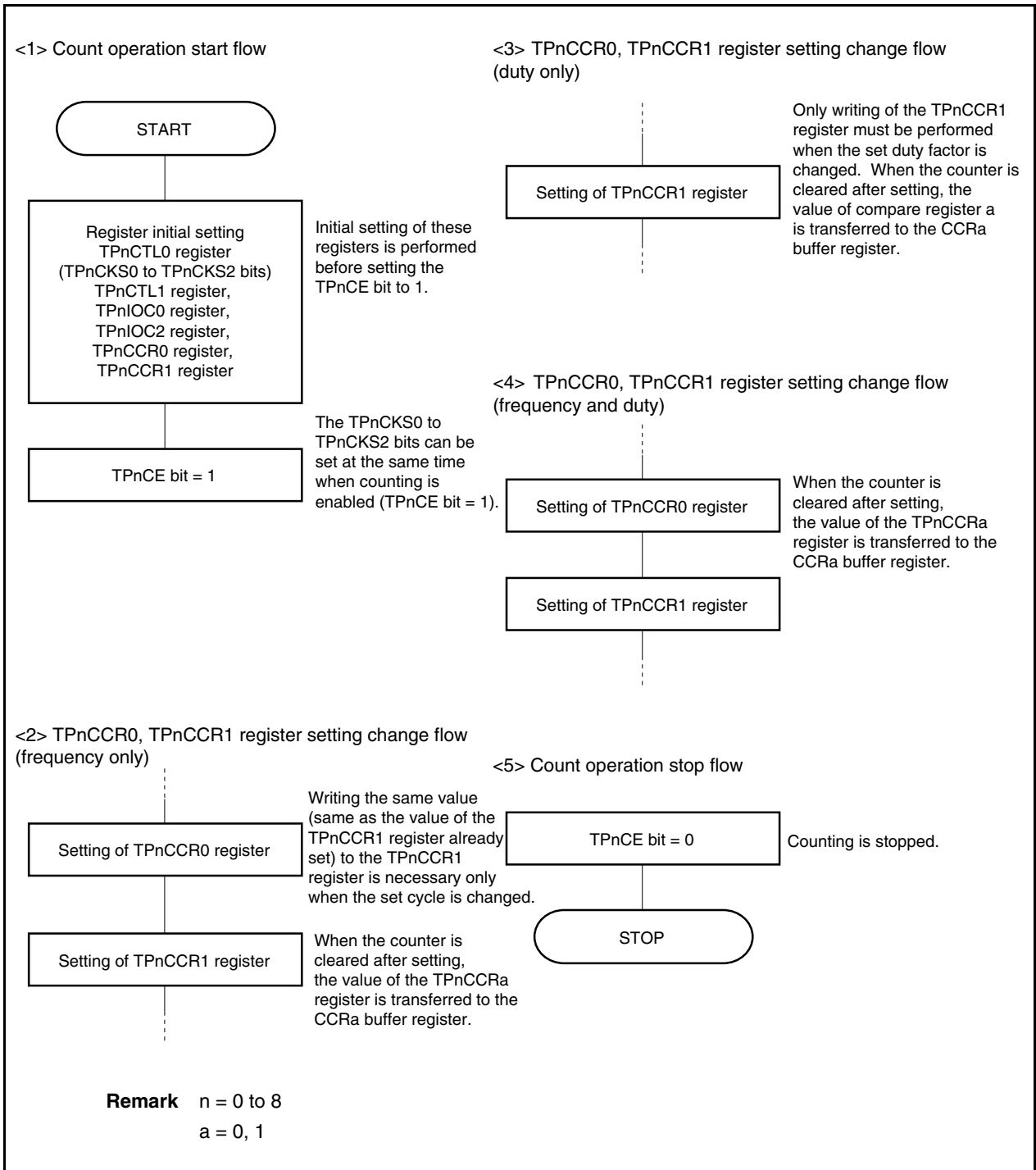

Figure 7-33. Software Processing Flow in PWM Output Mode (2/2)



**(2) PWM output mode operation timing****(a) Changing pulse width during operation**

To change the PWM waveform while the counter is operating, write the TPnCCR1 register last.

Rewrite the TPnCCRa register after writing the TPnCCR1 register after the INTTPnCC0 signal is detected.

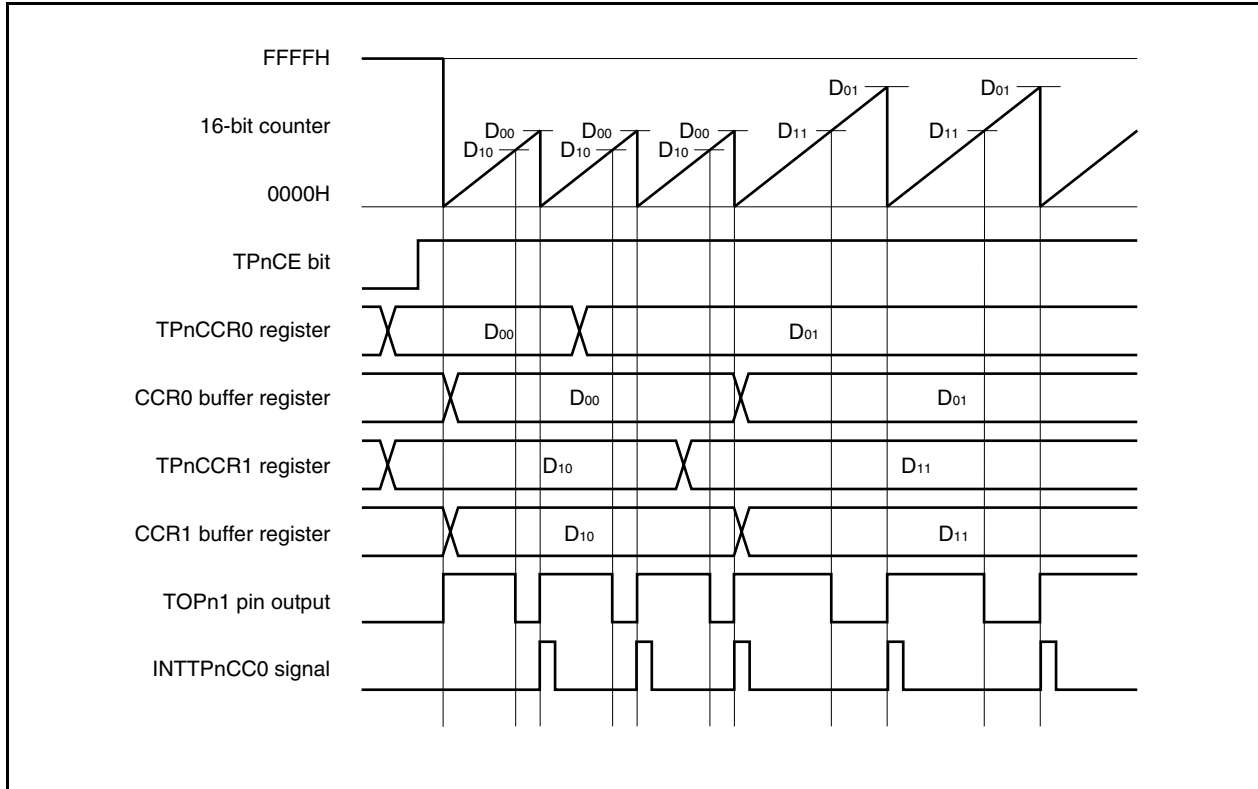

To transfer data from the TPnCCRa register to the CCRa buffer register, the TPnCCR1 register must be written.

To change both the cycle and active level of the PWM waveform at this time, first set the cycle to the TPnCCR0 register and then set the active level to the TPnCCR1 register.

To change only the cycle of the PWM waveform, first set the cycle to the TPnCCR0 register, and then write the same value (same as the value of the TPnCCR1 register already set) to the TPnCCR1 register.

To change only the active level width (duty factor) of the PWM waveform, only the TPnCCR1 register has to be set.

After data is written to the TPnCCR1 register, the value written to the TPnCCRa register is transferred to the CCRa buffer register in synchronization with clearing of the 16-bit counter, and is used as the value compared with the 16-bit counter.

To write the TPnCCR0 or TPnCCR1 register again after writing the TPnCCR1 register once, do so after the INTTPnCC0 signal is generated. Otherwise, the value of the CCRa buffer register may become undefined because the timing of transferring data from the TPnCCRa register to the CCRa buffer register conflicts with writing the TPnCCRa register.

**Remark** n = 0 to 8  
a = 0, 1

**(b) 0%/100% output of PWM waveform**

To output a 0% waveform, set the TPnCCR1 register to 0000H. The 16-bit counter is cleared to 0000H and the INTTPnCC0 and INTTPnCC1 signals are generated at the next timing after a match between the count value of the 16-bit counter and the value of the CCR0 buffer register.

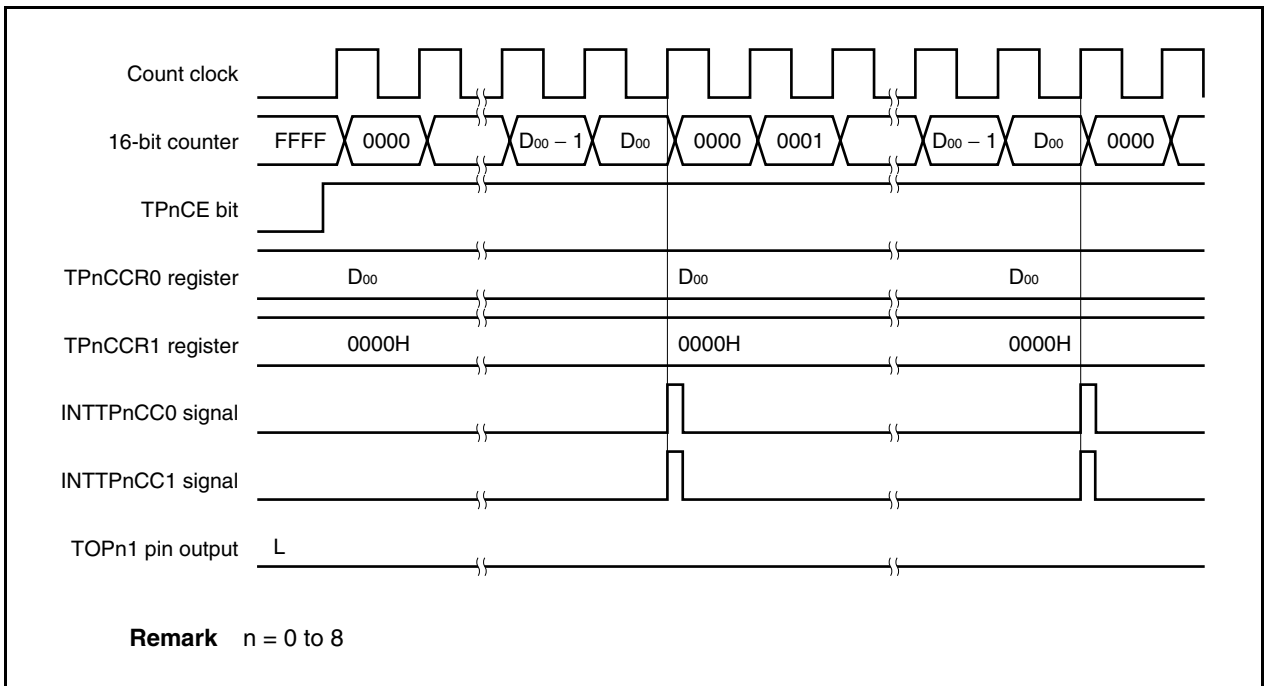

To output a 100% waveform, set a value of (set value of TPnCCR0 register + 1) to the TPnCCR1 register. If the set value of the TPnCCR0 register is FFFFH, 100% output cannot be produced.

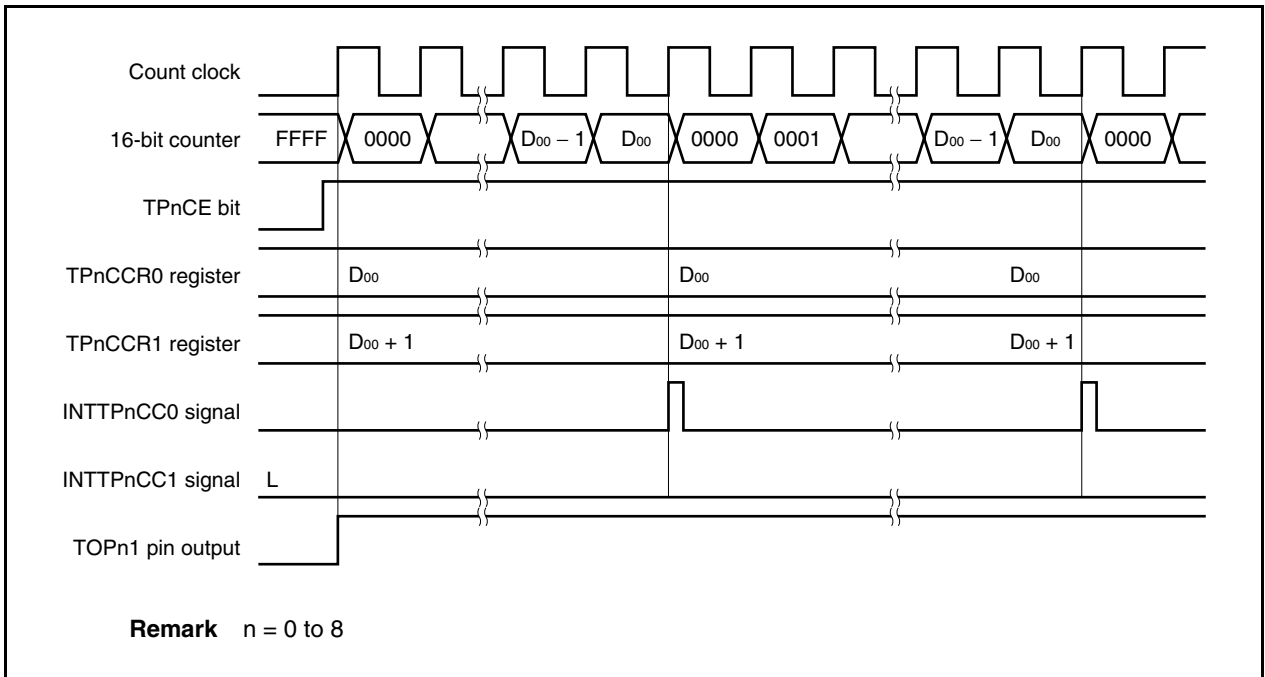

**(c) Generation timing of compare match interrupt request signal (INTTPnCC1)**

The timing of generation of the INTTPnCC1 signal in the PWM output mode differs from the timing of other mode INTTPnCC1 signals; the INTTPnCC1 signal is generated when the count value of the 16-bit counter matches the value of the TPnCCR1 register.

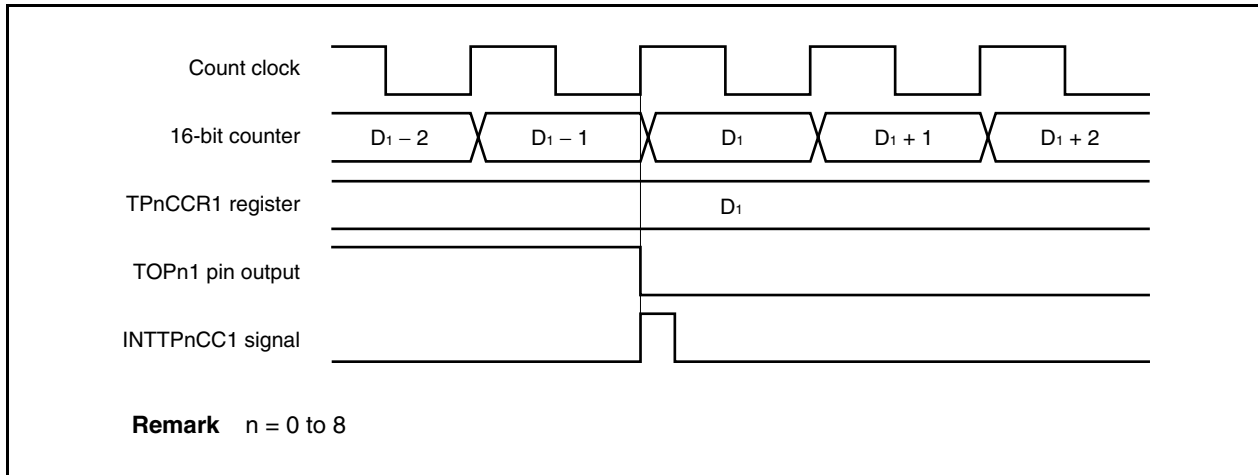

Usually, the INTTPnCC1 signal is generated in synchronization with the next counting up after the count value of the 16-bit counter matches the value of the TPnCCR1 register.

In the PWM output mode, however, it is generated one clock earlier. This is because the timing is changed to match the change timing of the output signal of the TOPn1 pin.

**7.6.6 Free-running timer mode (TPnMD2 to TPnMD0 bits = 101)**

In the free-running timer mode, 16-bit timer/event counter P starts counting when the TPnCTL0.TPnCE bit is set to 1. At this time, the TPnCCRa register can be used as a compare register or a capture register, depending on the setting of the TPnOPT0.TPnCCS0 and TPnOPT0.TPnCCS1 bits.

**Figure 7-34. Configuration in Free-Running Timer Mode**

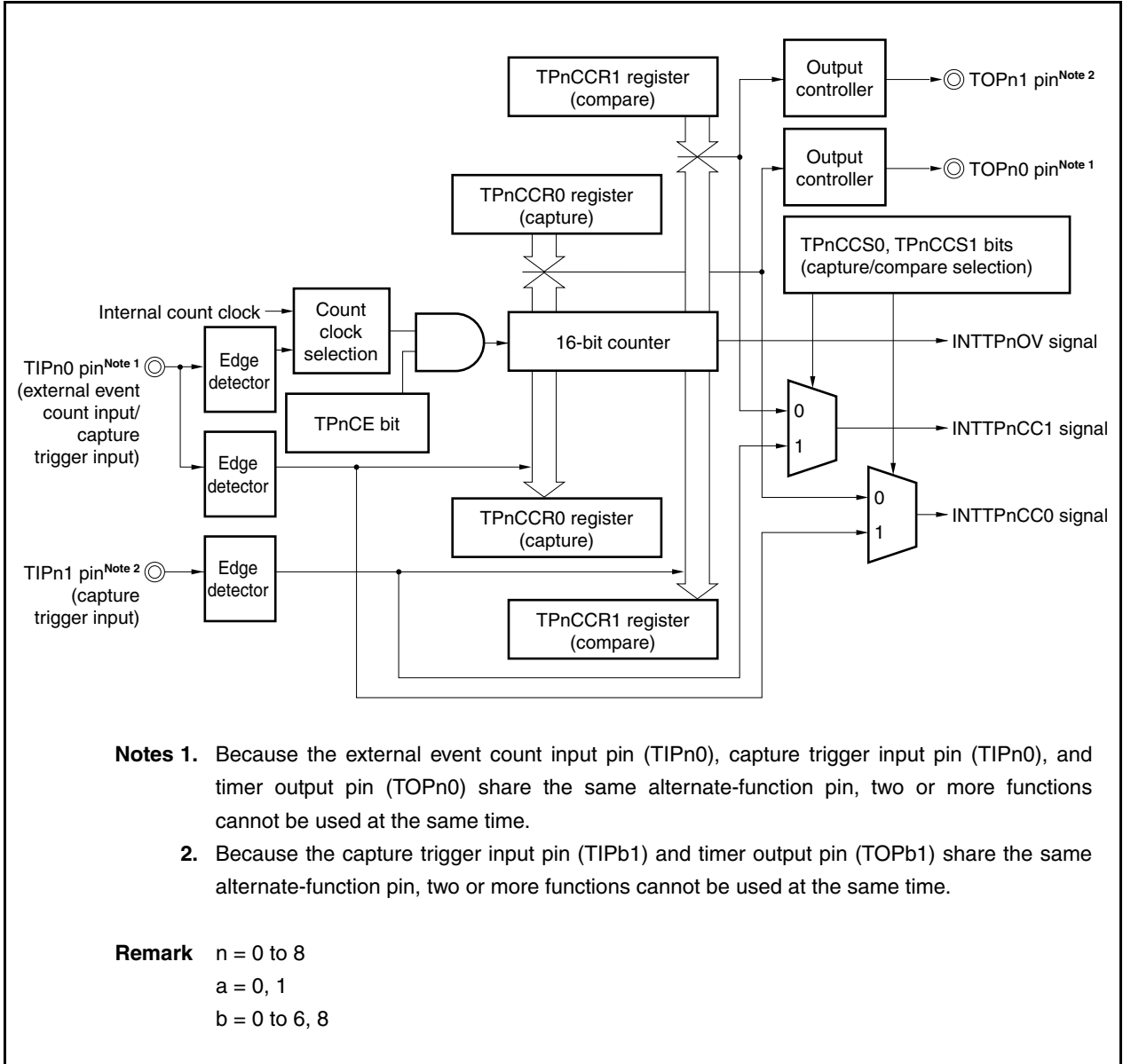

- Compare operation

When the TPnCE bit is set to 1, 16-bit timer/event counter P starts counting, and the output signals of the TOPn0 and TOPn1 pins are inverted. When the count value of the 16-bit counter later matches the set value of the TPnCCR<sub>a</sub> register, a compare match interrupt request signal (INTTPnCC<sub>a</sub>) is generated, and the output signal of the TOPn<sub>a</sub> pin is inverted.

The 16-bit counter continues counting in synchronization with the count clock. When it counts up to FFFFH, it generates an overflow interrupt request signal (INTTPnOV) at the next clock, is cleared to 0000H, and continues counting. At this time, the overflow flag (TPnOPT0.TPnOV<sub>F</sub> bit) is also set to 1. Confirm that the overflow flag is set to 1 and then clear it to 0 by executing the CLR instruction via software.

The TPnCCR<sub>a</sub> register can be rewritten while the counter is operating. If it is rewritten, the new value is reflected at that time by anytime write, and compared with the count value.

**Figure 7-35. Basic Timing in Free-Running Timer Mode (Compare Function)**

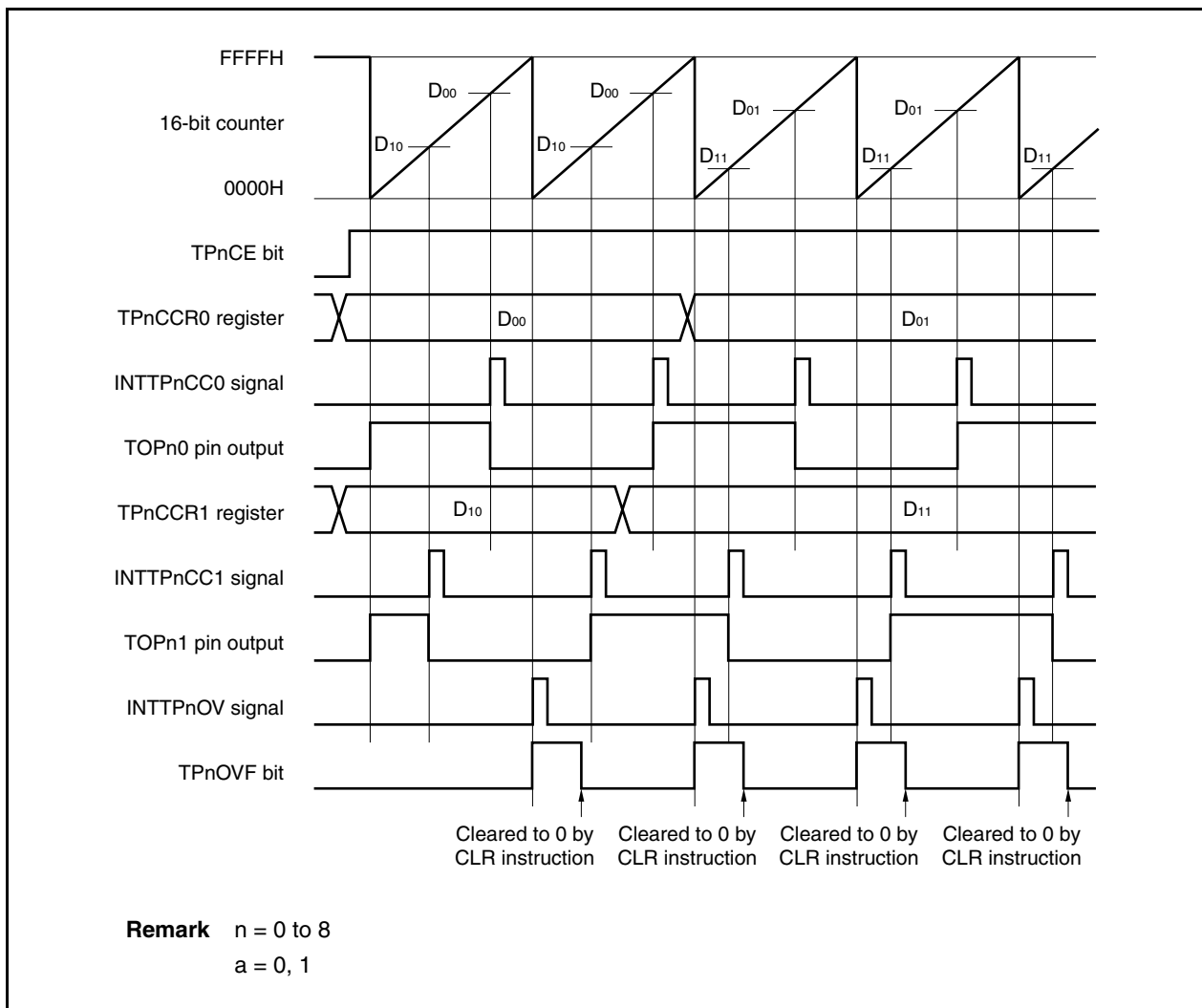



- Capture operation

When the TPnCE bit is set to 1, the 16-bit counter starts counting. When the valid edge input to the TIPna pin is detected, the count value of the 16-bit counter is stored in the TPnCCRa register, and a capture interrupt request signal (INTTPnCCa) is generated.

The 16-bit counter continues counting in synchronization with the count clock. When it counts up to FFFFH, it generates an overflow interrupt request signal (INTTPnOV) at the next clock, is cleared to 0000H, and continues counting. At this time, the overflow flag (TPnOPT0.TPnOVF bit) is also set to 1. Confirm that the overflow flag is set to 1 and then clear it to 0 by executing the CLR instruction via software.

**Figure 7-36. Basic Timing in Free-Running Timer Mode (Capture Function)**

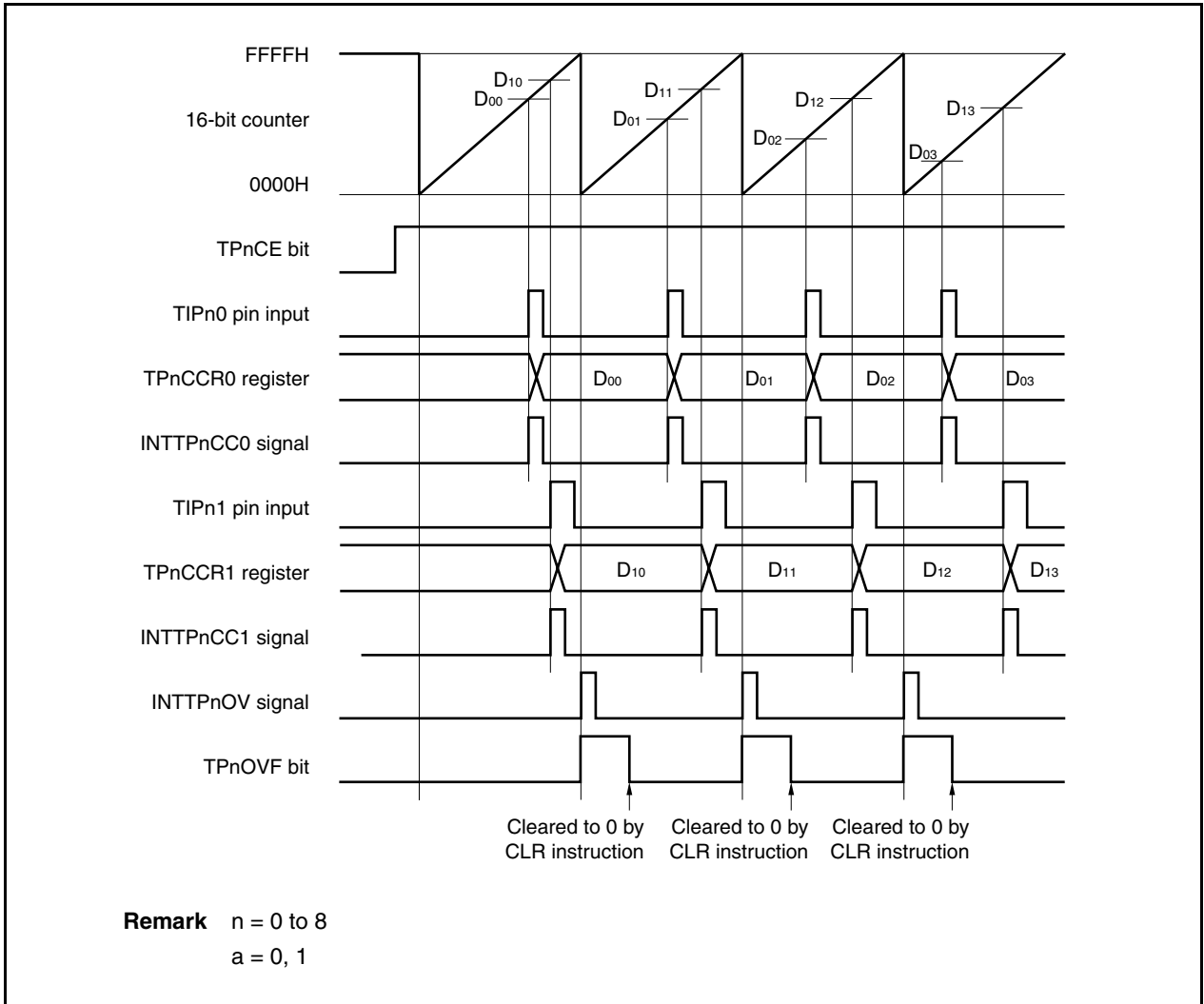

Figure 7-37. Register Setting in Free-Running Timer Mode (1/3)

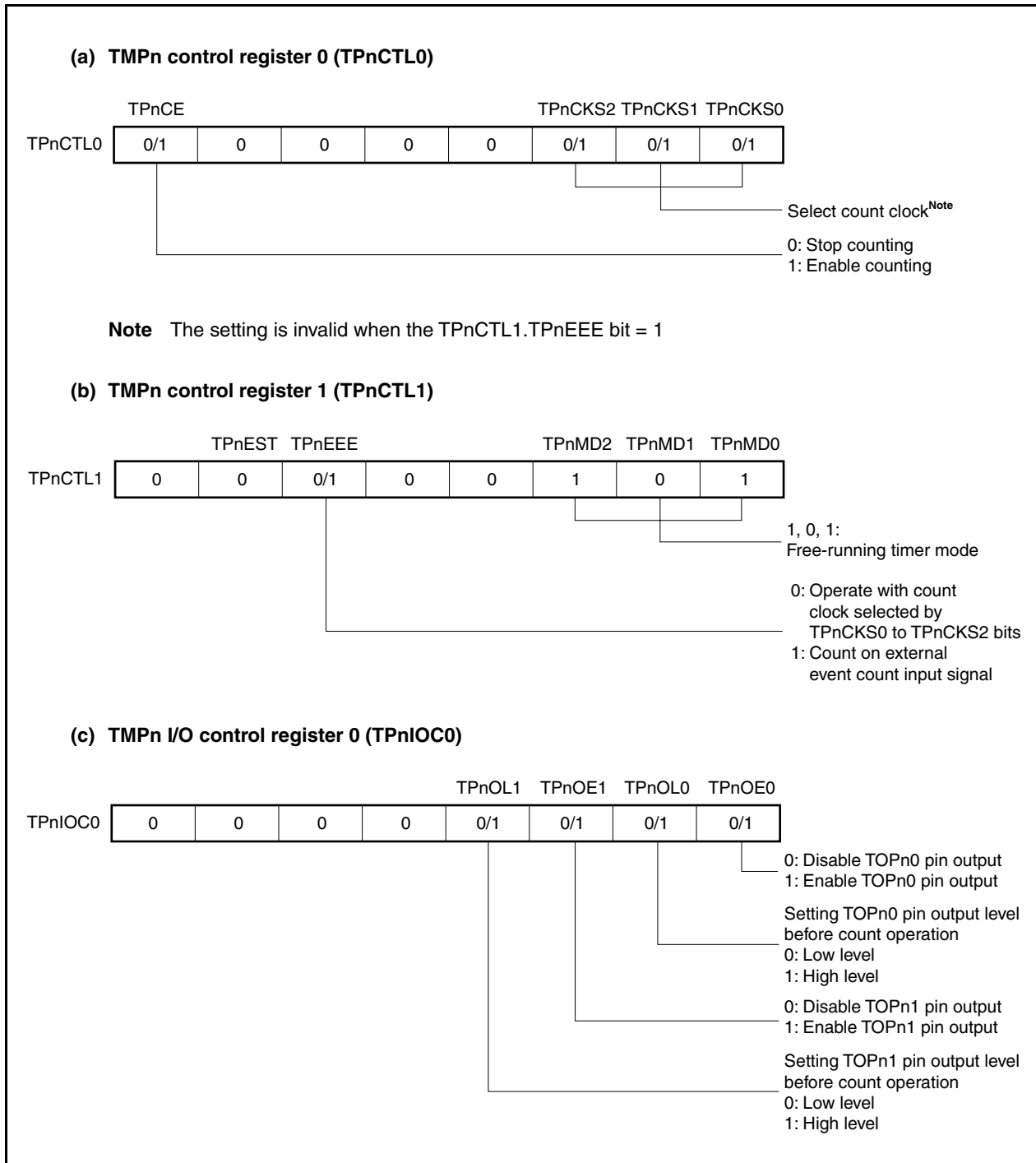

Figure 7-37. Register Setting in Free-Running Timer Mode (2/3)

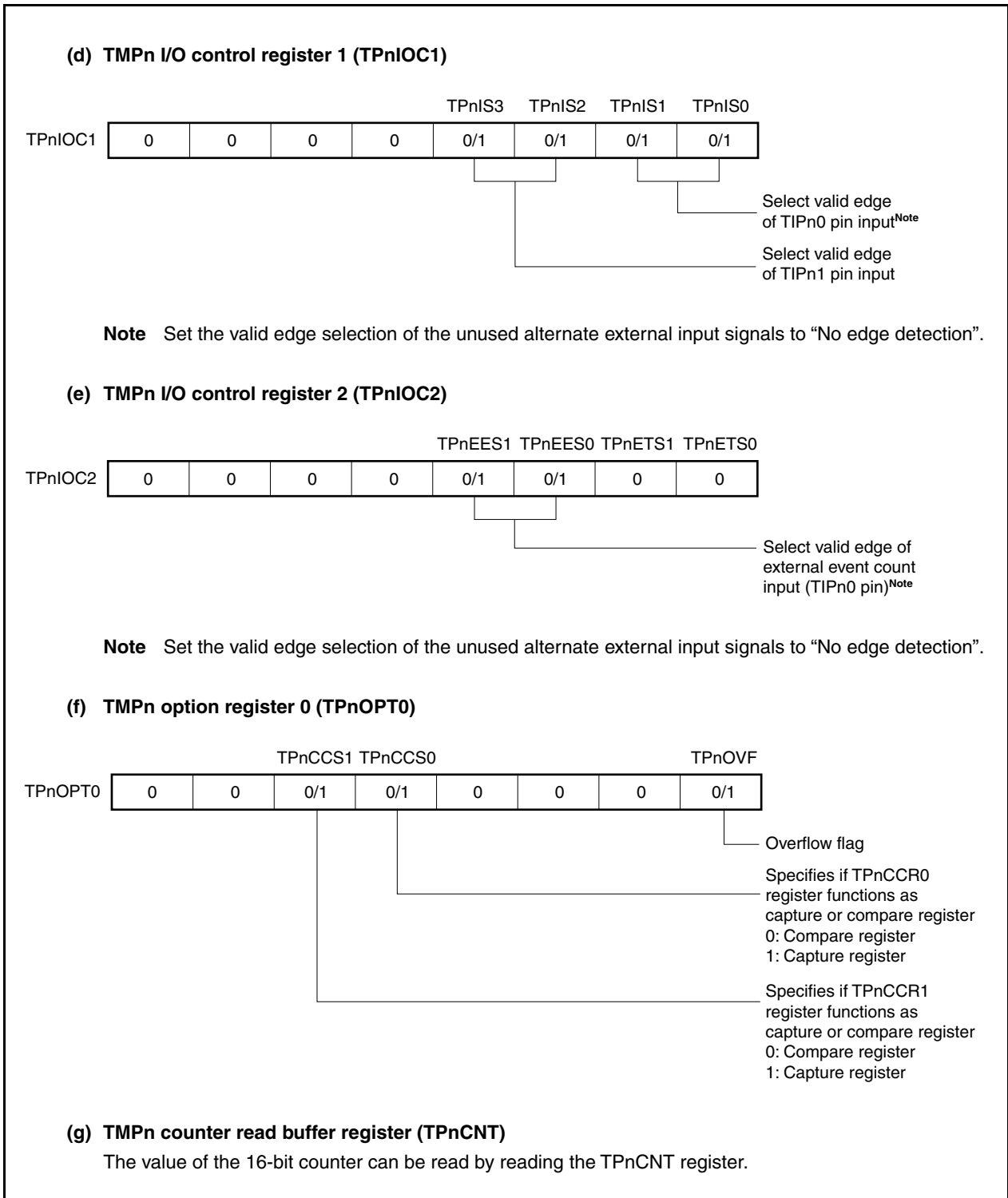

Figure 7-37. Register Setting in Free-Running Timer Mode (3/3)

**(h) TMPn capture/compare registers 0 and 1 (TPnCCR0 and TPnCCR1)**

These registers function as capture registers or compare registers depending on the setting of the TPnOPT0.TPnCCSa bit.

When the registers function as capture registers, they store the count value of the 16-bit counter when the valid edge input to the TIPna pin is detected.

When the registers function as compare registers and when  $D_a$  is set to the TPnCCR<sub>a</sub> register, the INTTPnCC<sub>a</sub> signal is generated when the counter reaches  $(D_a + 1)$ , and the output signal of the TOPna pin is inverted.

**Remark** n = 0 to 8  
a = 0, 1

(1) Operation flow in free-running timer mode

(a) When using capture/compare register as compare register

Figure 7-38. Software Processing Flow in Free-Running Timer Mode (Compare Function) (1/2)

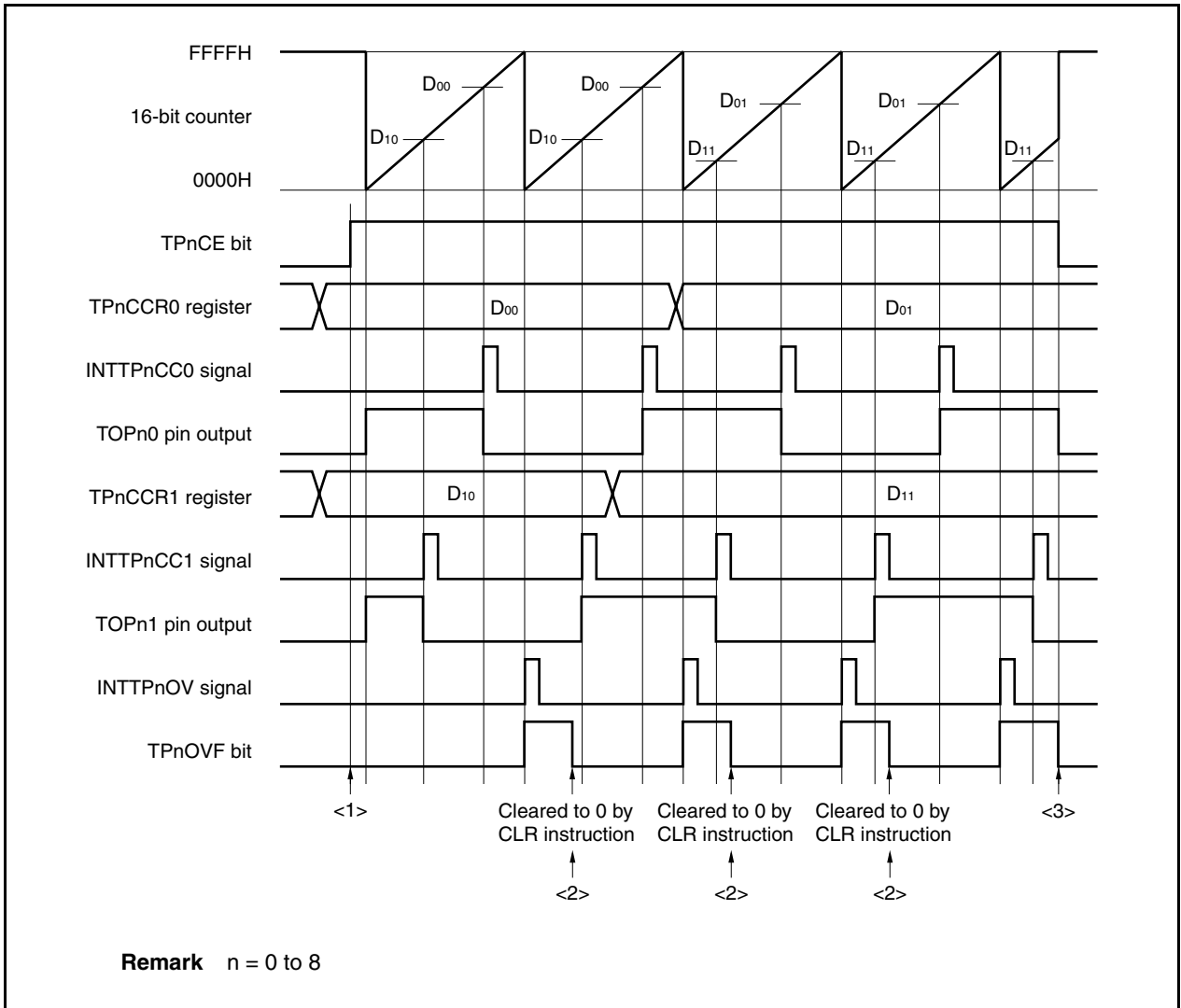
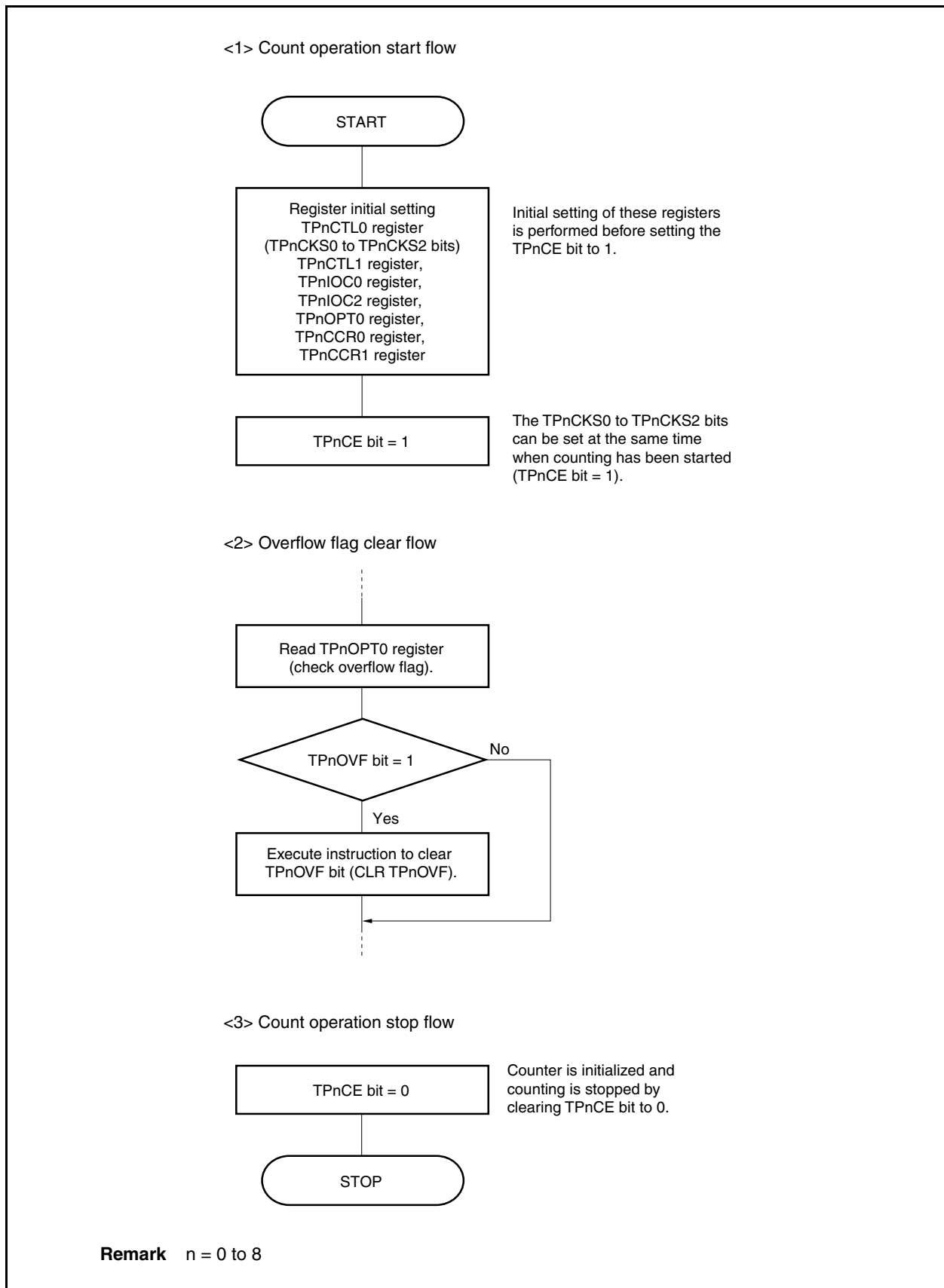

Figure 7-38. Software Processing Flow in Free-Running Timer Mode (Compare Function) (2/2)



(b) When using capture/compare register as capture register

Figure 7-39. Software Processing Flow in Free-Running Timer Mode (Capture Function) (1/2)

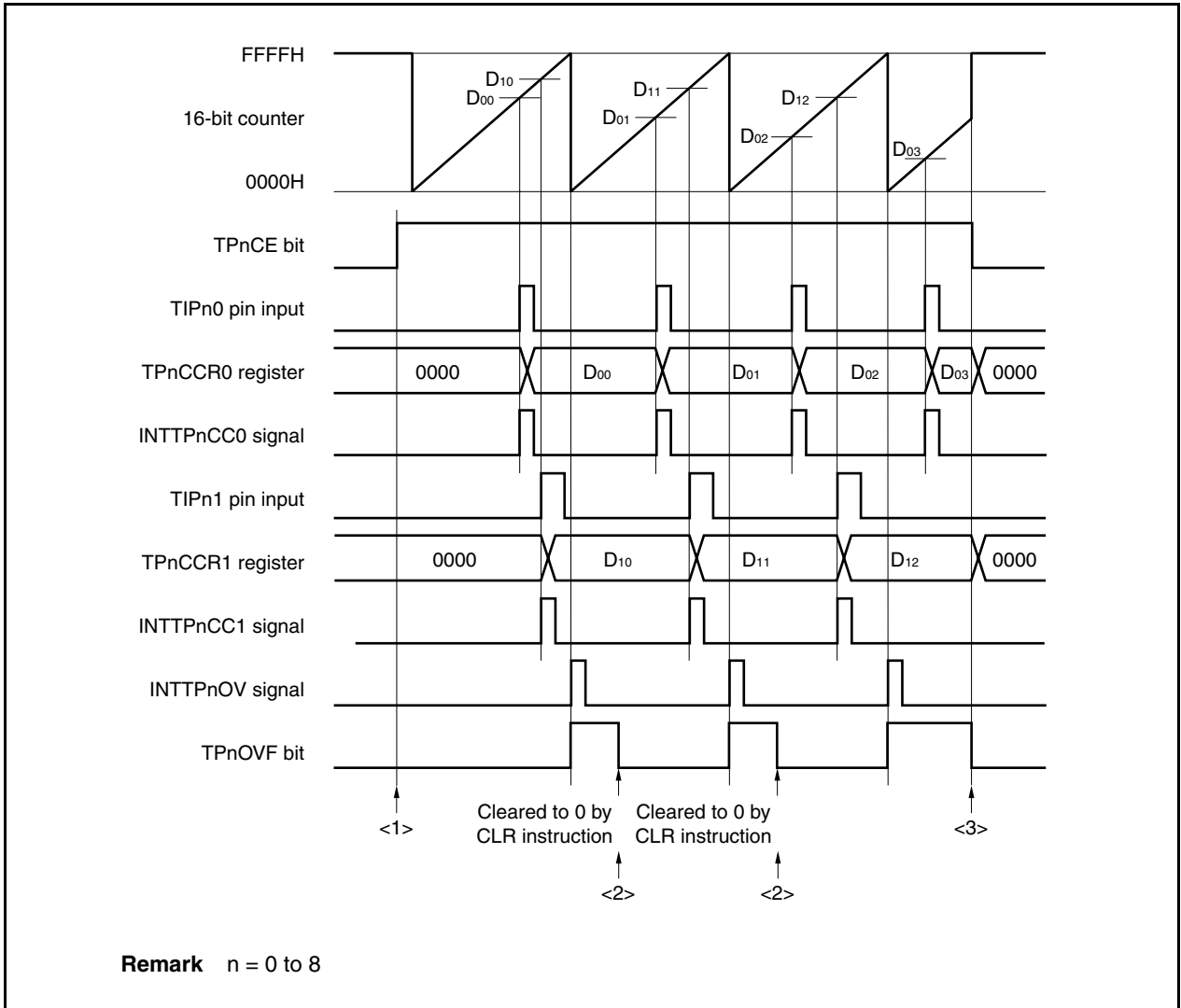
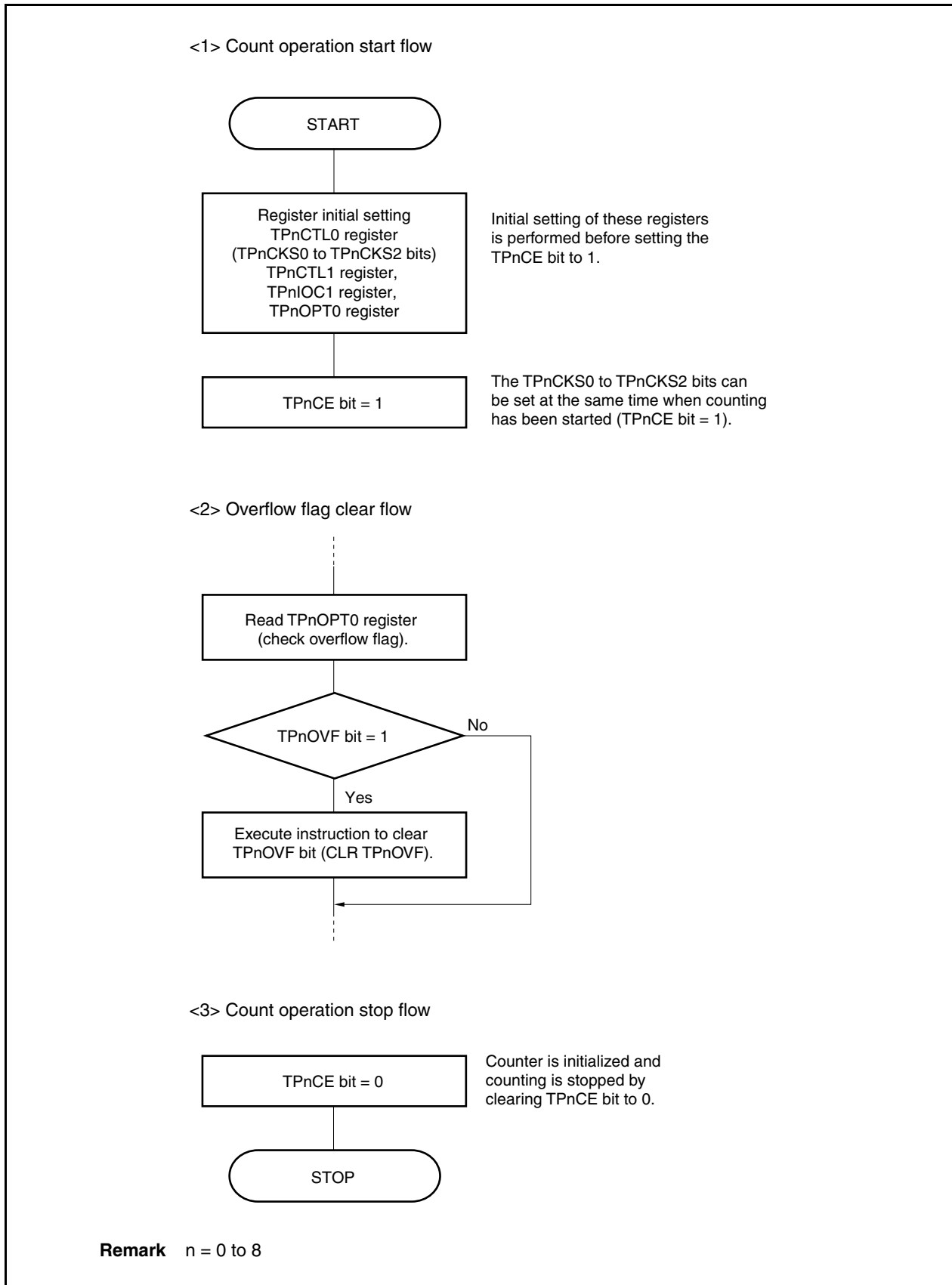

Figure 7-39. Software Processing Flow in Free-Running Timer Mode (Capture Function) (2/2)





(2) Operation timing in free-running timer mode

(a) Interval operation with compare register

When 16-bit timer/event counter P is used as an interval timer with the TPnCCRa register used as a compare register, software processing is necessary for setting a comparison value to generate the next interrupt request signal each time the INTTPnCCa signal has been detected.

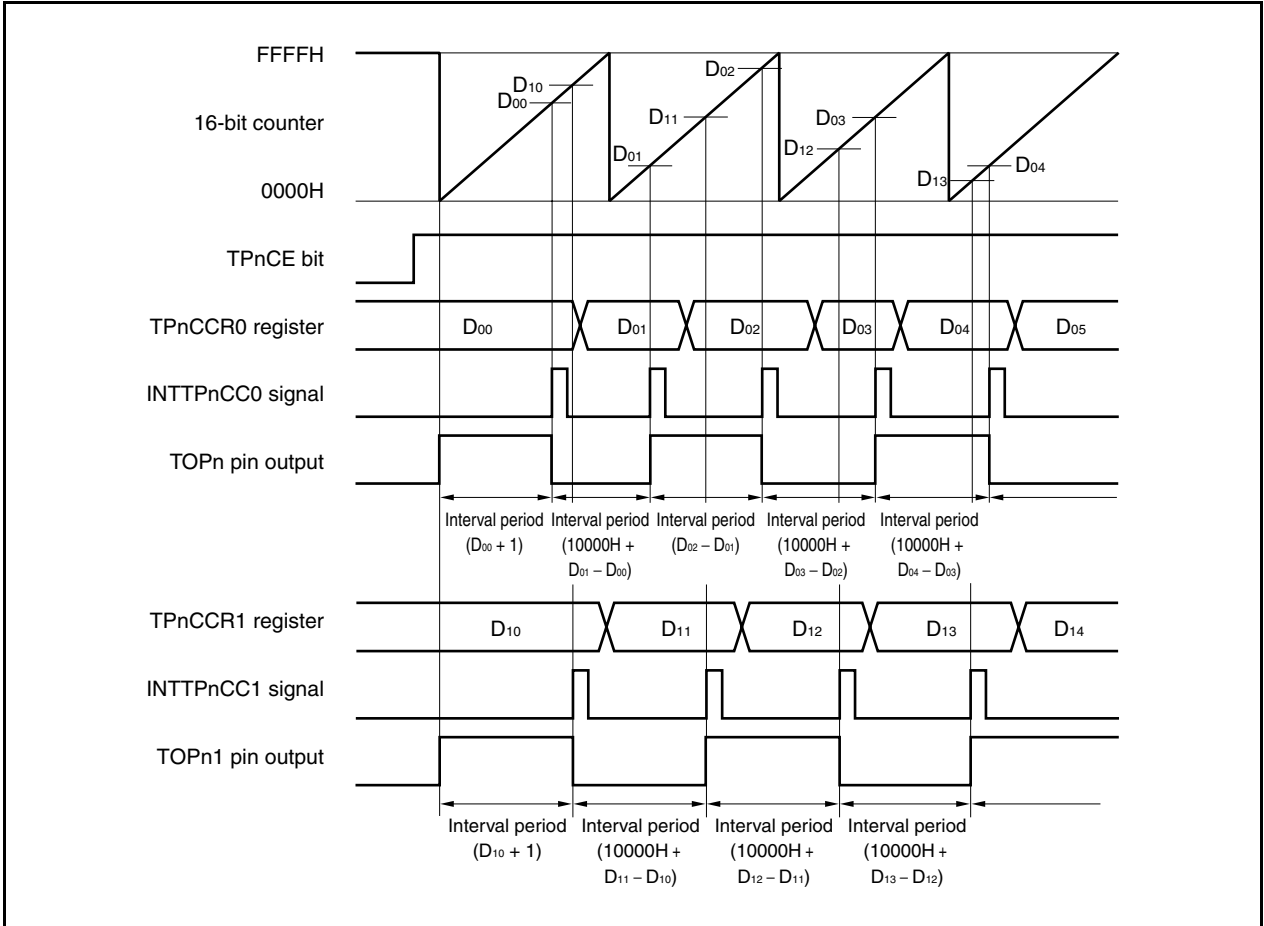

When performing an interval operation in the free-running timer mode, two intervals can be set with one channel.

To perform the interval operation, the value of the corresponding TPnCCRa register must be re-set in the interrupt servicing that is executed when the INTTPnCCa signal is detected.

The set value for re-setting the TPnCCRa register can be calculated by the following expression, where “Da” is the interval period.

Compare register default value:  $D_a - 1$

Value set to compare register second and subsequent time: Previous set value +  $D_a$

(If the calculation result is greater than FFFFH, subtract 10000H from the result and set this value to the register.)

**Remark** n = 0 to 8

a = 0, 1

**(b) Pulse width measurement with capture register**

When pulse width measurement is performed with the TPnCCRa register used as a capture register, software processing is necessary for reading the capture register each time the INTTPnCCa signal has been detected and for calculating an interval.

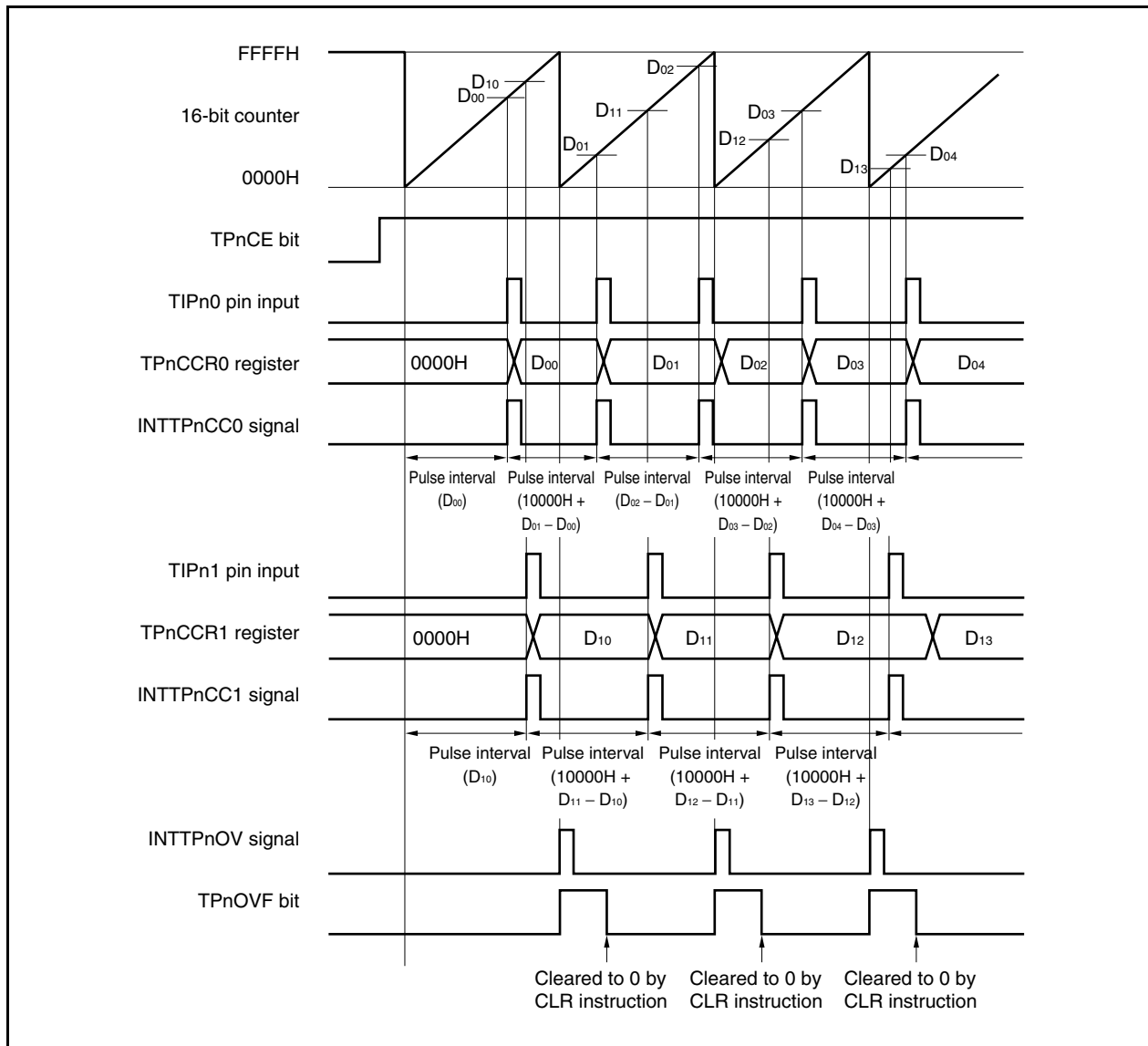

When executing pulse width measurement in the free-running timer mode, two pulse widths can be measured with one channel.

To measure a pulse width, the pulse width can be calculated by reading the value of the TPnCCRa register in synchronization with the INTTPnCCa signal, and calculating the difference between the read value and the previously read value.

**Remark** n = 0 to 8  
a = 0, 1

**(c) Processing of overflow when two capture registers are used**

Care must be exercised in processing the overflow flag when two capture registers are used. First, an example of incorrect processing is shown below.

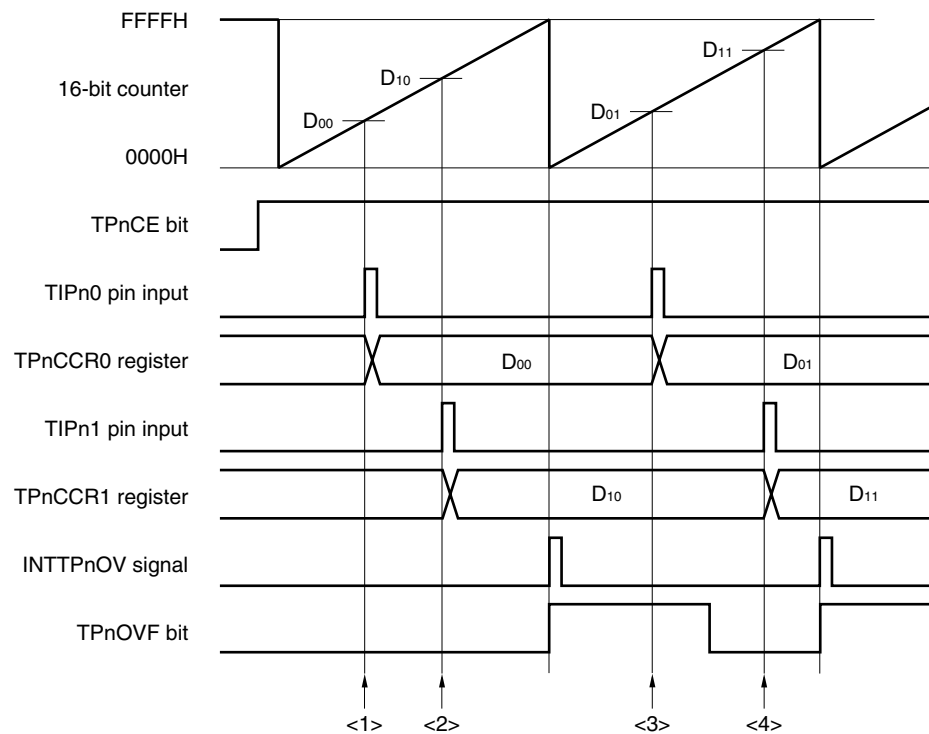
**Example of incorrect processing when two capture registers are used**

The following problem may occur when two pulse widths are measured in the free-running timer mode.

- <1> Read the TPnCCR0 register (setting of the default value of the TIPn0 pin input).
- <2> Read the TPnCCR1 register (setting of the default value of the TIPn1 pin input).
- <3> Read the TPnCCR0 register.  
Read the overflow flag. If the overflow flag is 1, clear it to 0.  
Because the overflow flag is 1, the pulse width can be calculated by  $(10000H + D_{01} - D_{00})$ .
- <4> Read the TPnCCR1 register.  
Read the overflow flag. Because the flag is cleared in <3>, 0 is read.  
Because the overflow flag is 0, the pulse width can be calculated by  $(D_{11} - D_{10})$  (incorrect).

**Remark** n = 0 to 8

When two capture registers are used, and if the overflow flag is cleared to 0 by one capture register, the other capture register may not obtain the correct pulse width.

Use software when using two capture registers. An example of how to use software is shown below.

### Example when two capture registers are used (using overflow interrupt)

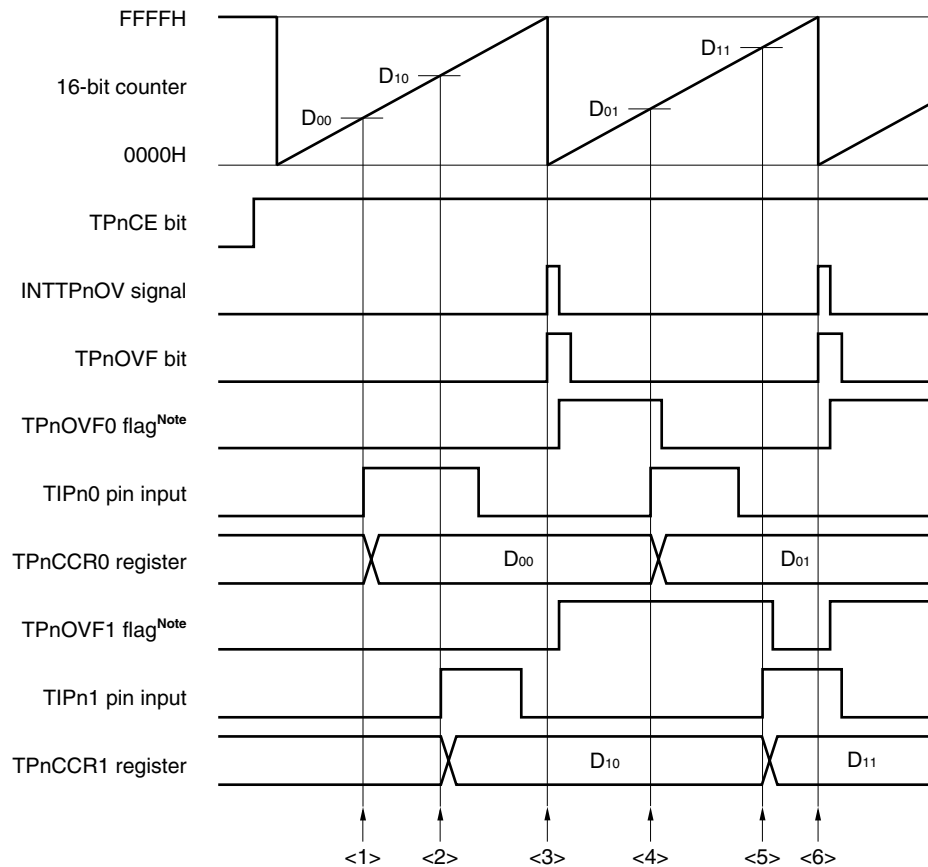

**Note** The TPnOVF0 and TPnOVF1 flags are set on the internal RAM by software.

- <1> Read the TPnCCR0 register (setting of the default value of the TIPn0 pin input).
- <2> Read the TPnCCR1 register (setting of the default value of the TIPn1 pin input).
- <3> An overflow occurs. Set the TPnOVF0 and TPnOVF1 flags to 1 in the overflow interrupt servicing, and clear the overflow flag to 0.
- <4> Read the TPnCCR0 register.  
Read the TPnOVF0 flag. If the TPnOVF0 flag is 1, clear it to 0.  
Because the TPnOVF0 flag is 1, the pulse width can be calculated by  $(10000H + D_{01} - D_{00})$ .
- <5> Read the TPnCCR1 register.  
Read the TPnOVF1 flag. If the TPnOVF1 flag is 1, clear it to 0 (the TPnOVF0 flag is cleared in <4>, and the TPnOVF1 flag remains 1).  
Because the TPnOVF1 flag is 1, the pulse width can be calculated by  $(10000H + D_{11} - D_{10})$  (correct).
- <6> Same as <3>

**Remark**  $n = 0$  to 8

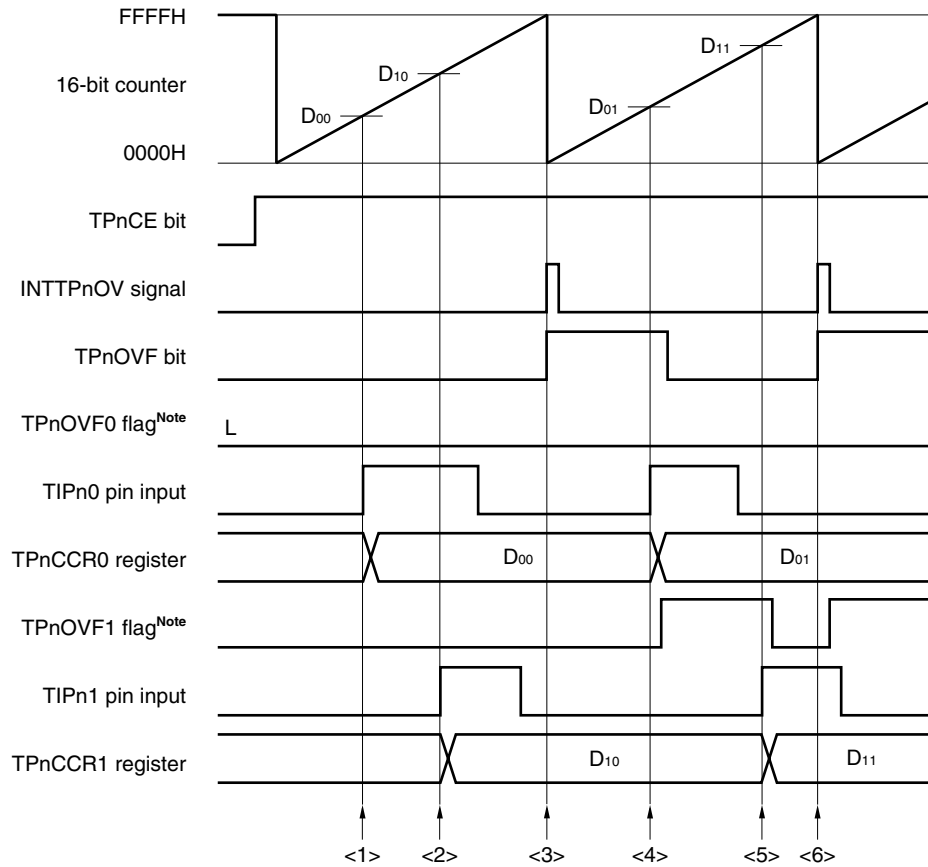
**Example when two capture registers are used (without using overflow interrupt)**

**Note** The TPnOVF0 and TPnOVF1 flags are set on the internal RAM by software.

<1> Read the TPnCCR0 register (setting of the default value of the TIPn0 pin input).

<2> Read the TPnCCR1 register (setting of the default value of the TIPn1 pin input).

<3> An overflow occurs. Nothing is done by software.

<4> Read the TPnCCR0 register.

Read the overflow flag. If the overflow flag is 1, set only the TPnOVF1 flag to 1, and clear the overflow flag to 0.

Because the overflow flag is 1, the pulse width can be calculated by  $(10000H + D_{01} - D_{00})$ .

<5> Read the TPnCCR1 register.

Read the overflow flag. Because the overflow flag is cleared in <4>, 0 is read.

Read the TPnOVF1 flag. If the TPnOVF1 flag is 1, clear it to 0.

Because the TPnOVF1 flag is 1, the pulse width can be calculated by  $(10000H + D_{11} - D_{10})$  (correct).

<6> Same as <3>

**Remark**  $n = 0$  to 8

**(d) Processing of overflow if capture trigger interval is long**

If the pulse width is greater than one cycle of the 16-bit counter, care must be exercised because an overflow may occur more than once from the first capture trigger to the next. First, an example of incorrect processing is shown below.

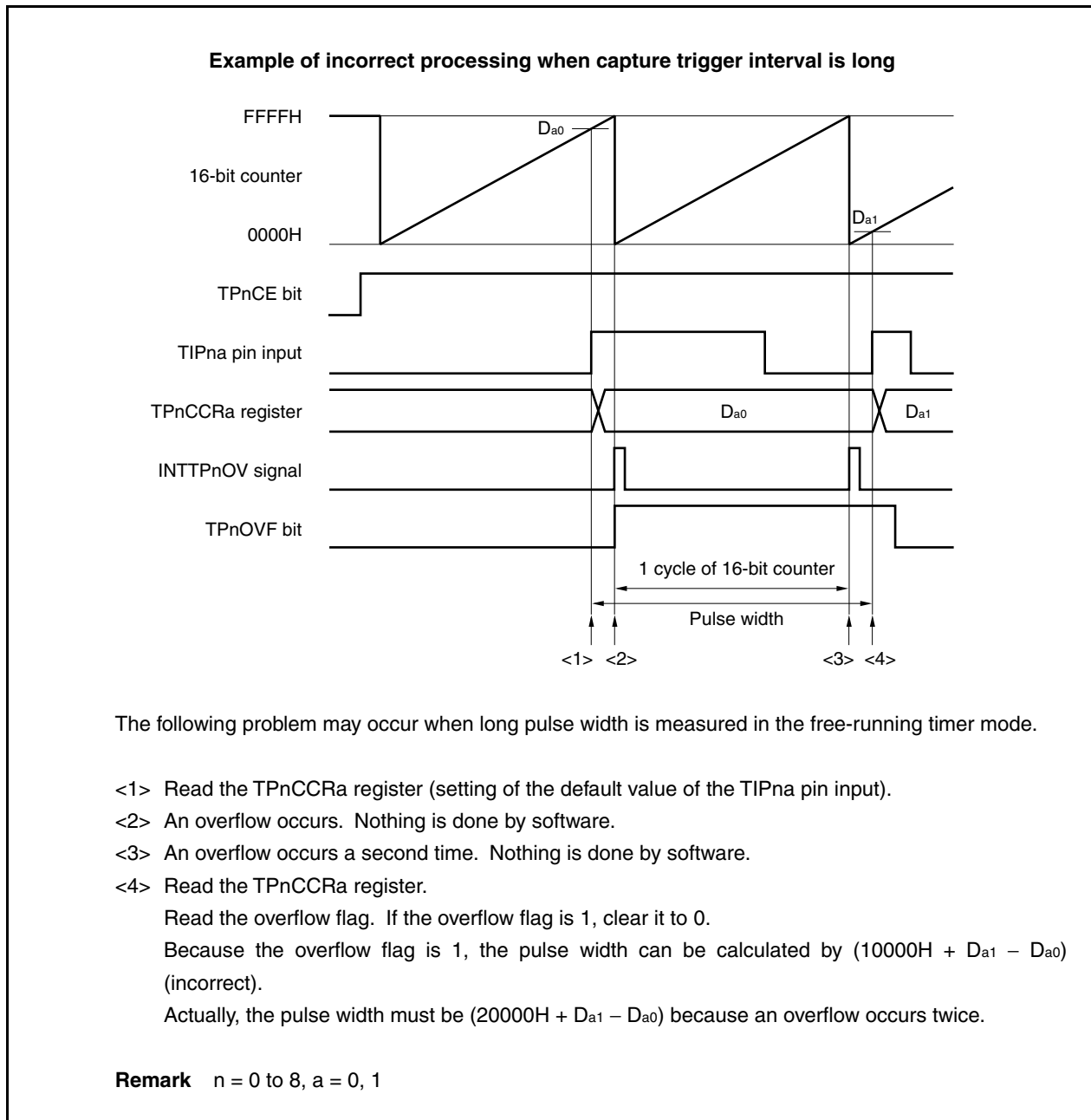

If an overflow occurs twice or more when the capture trigger interval is long, the correct pulse width may not be obtained.

If the capture trigger interval is long, slow the count clock to lengthen one cycle of the 16-bit counter, or use software. An example of how to use software is shown next.

## Example when capture trigger interval is long

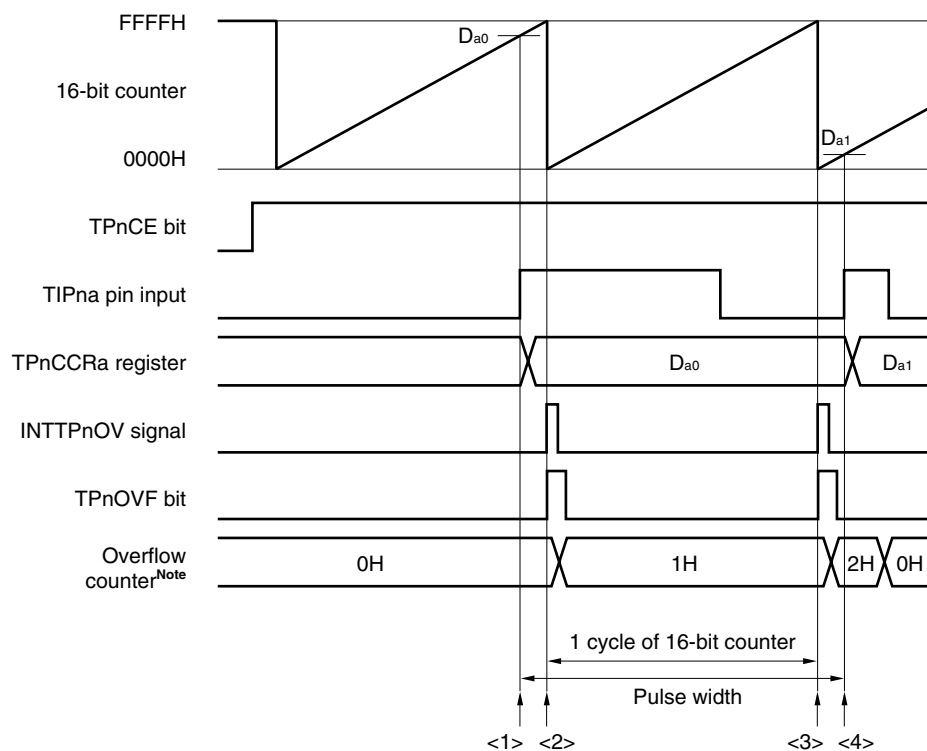

**Note** The overflow counter is set arbitrarily by software on the internal RAM.

- <1> Read the TPnCCRa register (setting of the default value of the TIPna pin input).
  - <2> An overflow occurs. Increment the overflow counter and clear the overflow flag to 0 in the overflow interrupt servicing.
  - <3> An overflow occurs a second time. Increment (+1) the overflow counter and clear the overflow flag to 0 in the overflow interrupt servicing.
  - <4> Read the TPnCCRa register.  
Read the overflow counter.  
→ When the overflow counter is “N”, the pulse width can be calculated by  $(N \times 10000H + D_{a1} - D_{a0})$ .
- In this example, the pulse width is  $(20000H + D_{a1} - D_{a0})$  because an overflow occurs twice.  
Clear the overflow counter (0H).

**Remark**  $n = 0$  to 8  
 $a = 0, 1$

**(e) Clearing overflow flag**

The overflow flag can be cleared to 0 by clearing the TPnOVF bit to 0 with the CLR instruction after reading the TPnOVF bit when it is 1 and by writing 8-bit data (bit 0 is 0) to the TPnOPT0 register after reading the TPnOVF bit when it is 1.

**(3) Note on capture operation**

When the capture operation is used and a slow clock is selected as the count clock, FFFFH, not 0000H, may be captured in the TPnCCRa register, or the capture operation may not be performed (capture interrupt does not occur) if the capture trigger is input immediately after the TPnCTL0.TPnCE bit is set to 1.

The same operation results during the period in which no external event counts are input while the capture operation is used and an external event count input is used as a count clock.

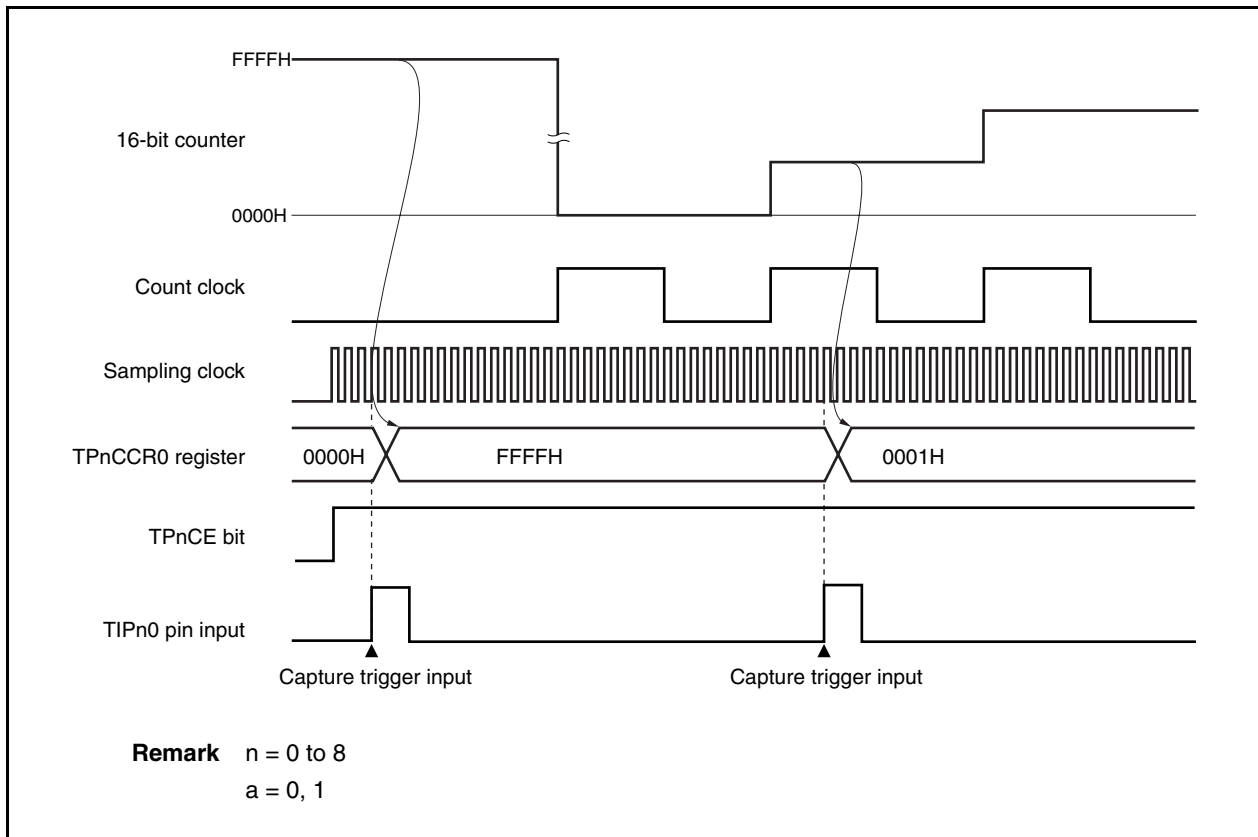



### 7.6.7 Pulse width measurement mode (TPnMD2 to TPnMD0 bits = 110)

In the pulse width measurement mode, 16-bit timer/event counter P starts counting when the TPnCTL0.TPnCE bit is set to 1. Each time the valid edge input to the TIPna pin has been detected, the count value of the 16-bit counter is stored in the TPnCCRa register, and the 16-bit counter is cleared to 0000H.

The interval of the valid edge can be measured by reading the TPnCCRa register after a capture interrupt request signal (INTTPnCCa) occurs.

For example, in case of Figure 7-41, select either the TIPn0 or TIPn1 pin as the capture trigger input pin, and specify “No edge detected” by using the TPnIOC1 register for the unused pin.

**Figure 7-40. Configuration in Pulse Width Measurement Mode**

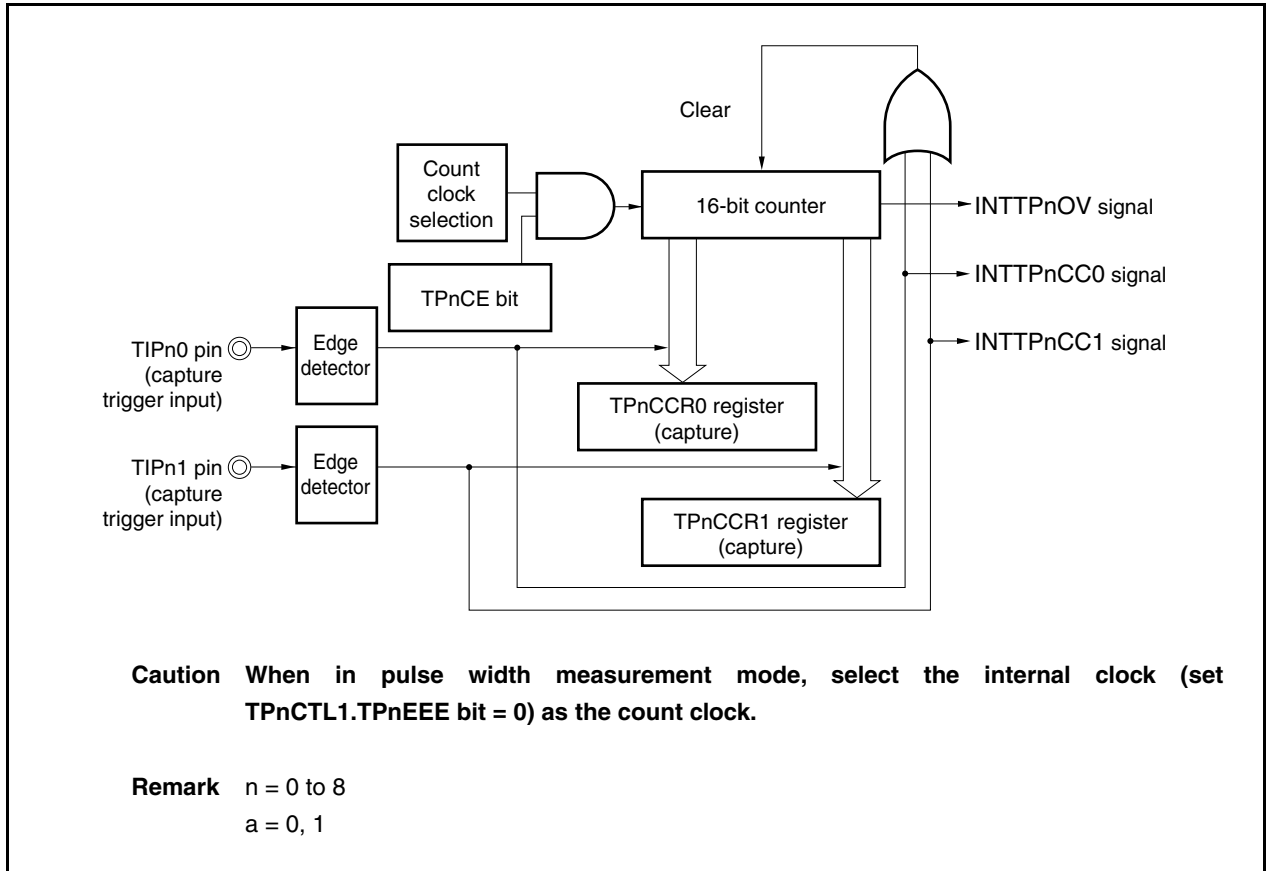
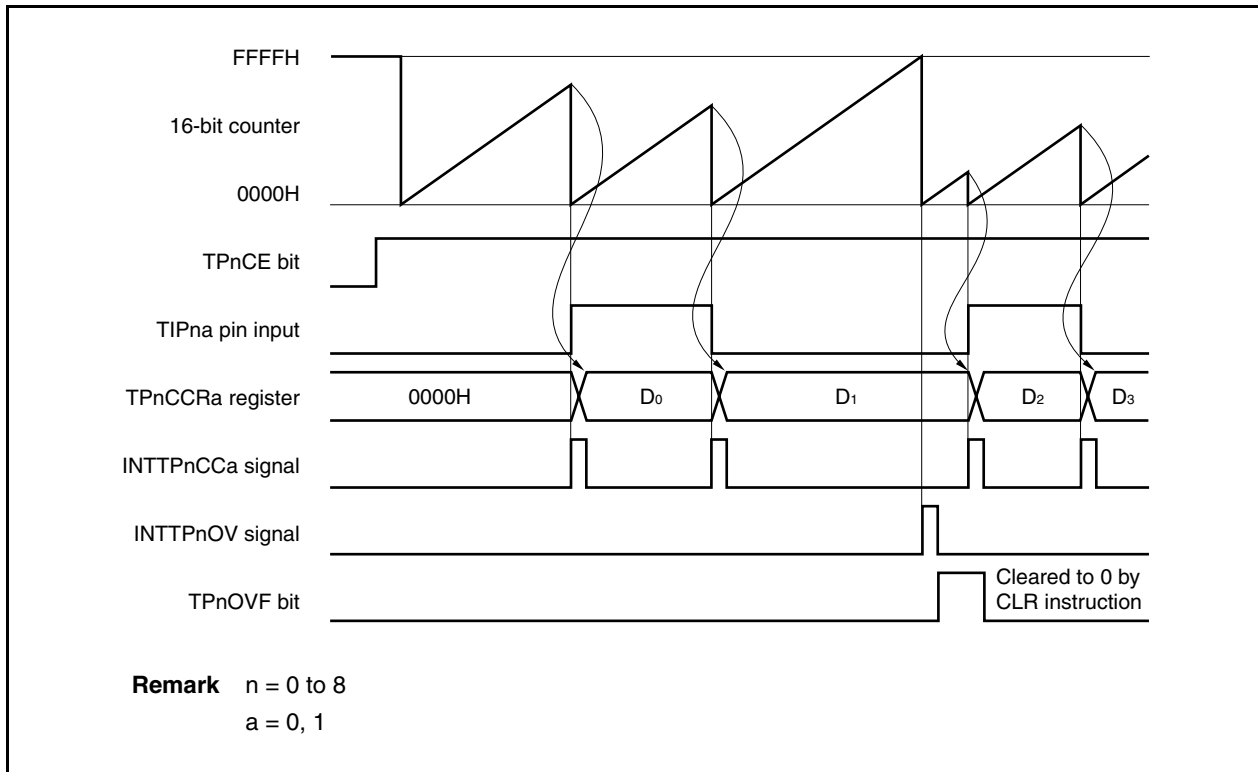

Figure 7-41. Basic Timing in Pulse Width Measurement Mode



When the TPnCE bit is set to 1, the 16-bit counter starts counting. When the valid edge input to the TIPna pin is later detected, the count value of the 16-bit counter is stored in the TPnCCRa register, the 16-bit counter is cleared to 0000H, and a capture interrupt request signal (INTTPnCCa) is generated.

The pulse width is calculated as follows.

$$\text{Pulse width} = \text{Captured value} \times \text{Count clock cycle}$$

If the valid edge is not input to the TIPnm pin even when the 16-bit counter counted up to FFFFH, an overflow interrupt request signal (INTTPnOV) is generated at the next count clock, and the counter is cleared to 0000H and continues counting. At this time, the overflow flag (TPnOPT0.TPnOVF bit) is also set to 1. Clear the overflow flag to 0 by executing the CLR instruction via software.

If the overflow flag is set to 1, the pulse width can be calculated as follows.

$$\text{Pulse width} = (10000H \times \text{TPnOVF bit set (1) count} + \text{Captured value}) \times \text{Count clock cycle}$$

**Remark** n = 0 to 8  
a = 0, 1

Figure 7-42. Register Setting in Pulse Width Measurement Mode (1/2)

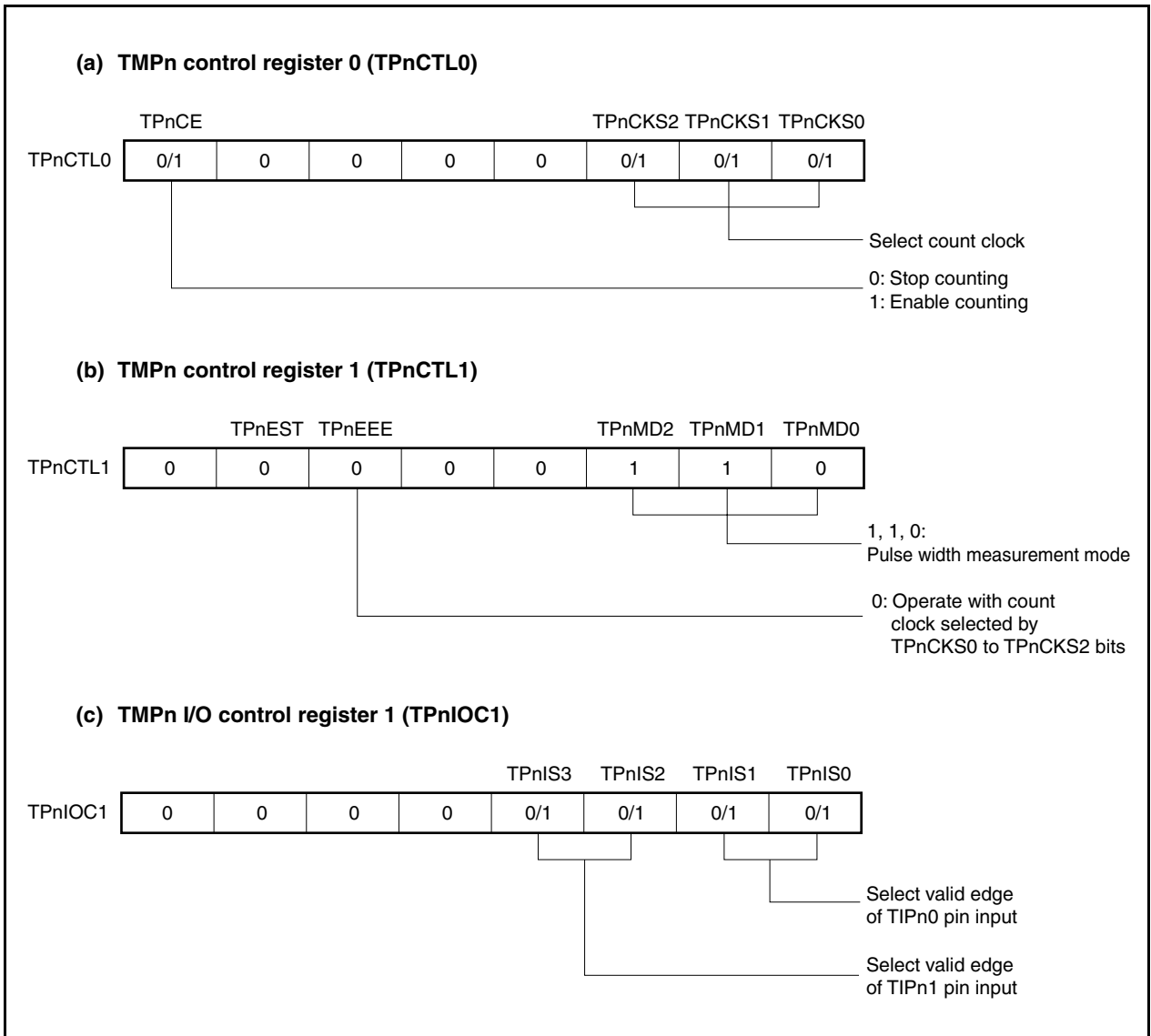
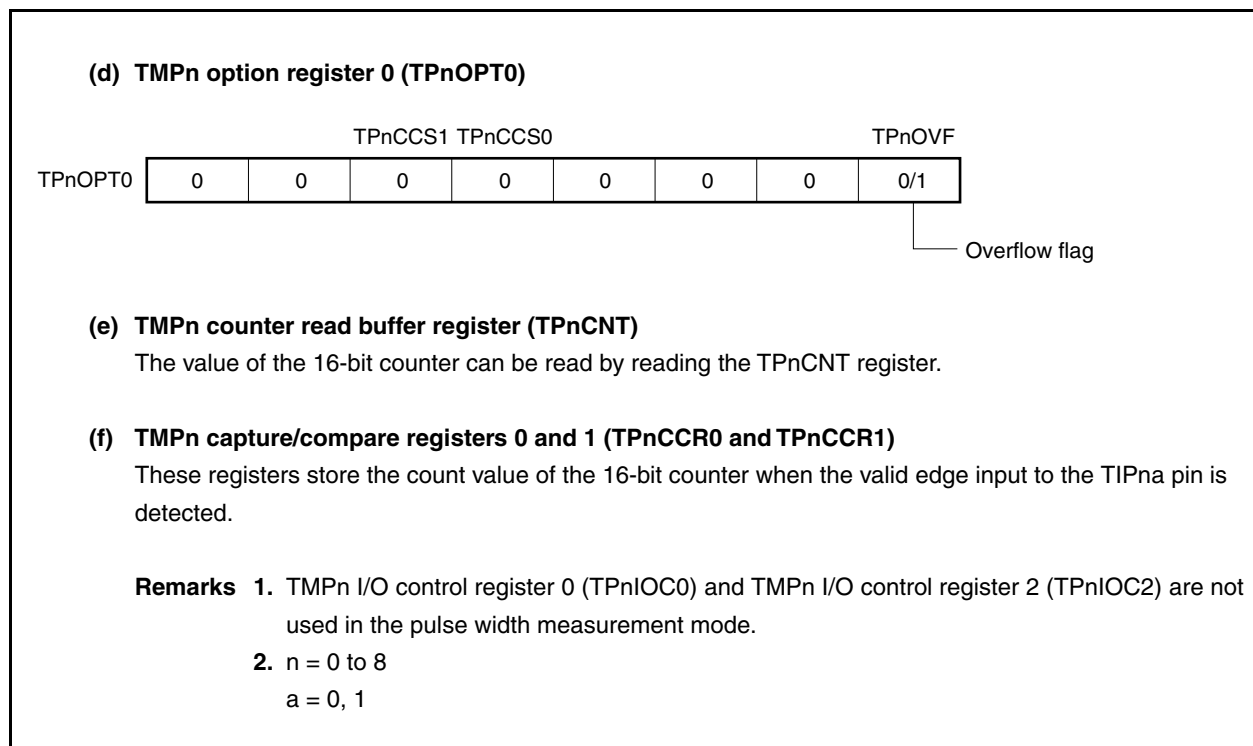
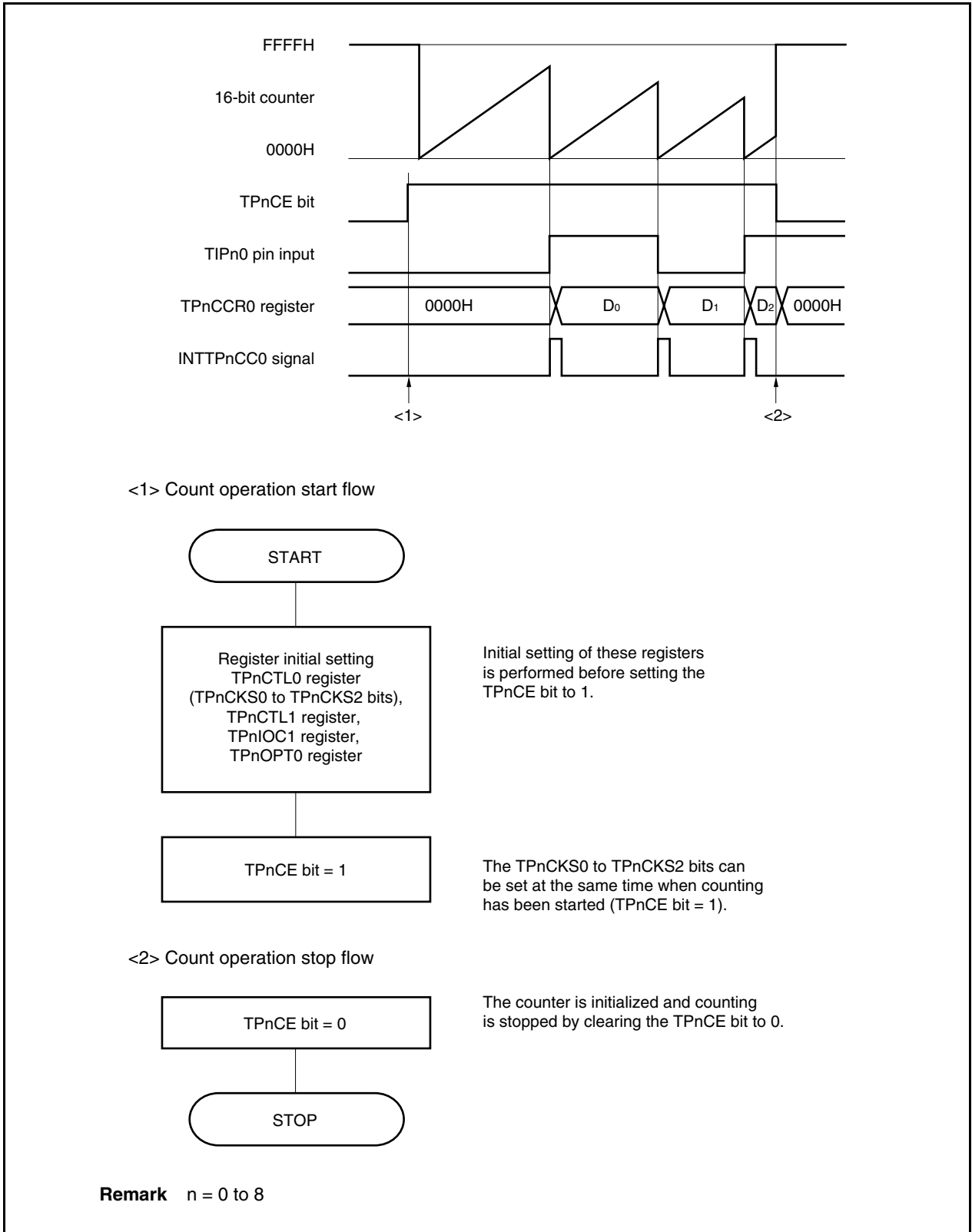

Figure 7-42. Register Setting in Pulse Width Measurement Mode (2/2)



(1) Operation flow in pulse width measurement mode

Figure 7-43. Software Processing Flow in Pulse Width Measurement Mode



**(2) Operation timing in pulse width measurement mode****(a) Clearing overflow flag**

The overflow flag can be cleared to 0 by clearing the TPnOVF bit to 0 with the CLR instruction after reading the TPnOVF bit when it is 1 and by writing 8-bit data (bit 0 is 0) to the TPnOPT0 register after reading the TPnOVF bit when it is 1.

**(3) Notes**

If a slow clock is selected as the count clock, FFFFH, not 0000H, may be captured to the TPnCCRa register, or the capture operation may not be performed (capture interrupt does not occur) if the capture trigger is input immediately after the TPnCTL0.TPnCE bit has been set to 1.

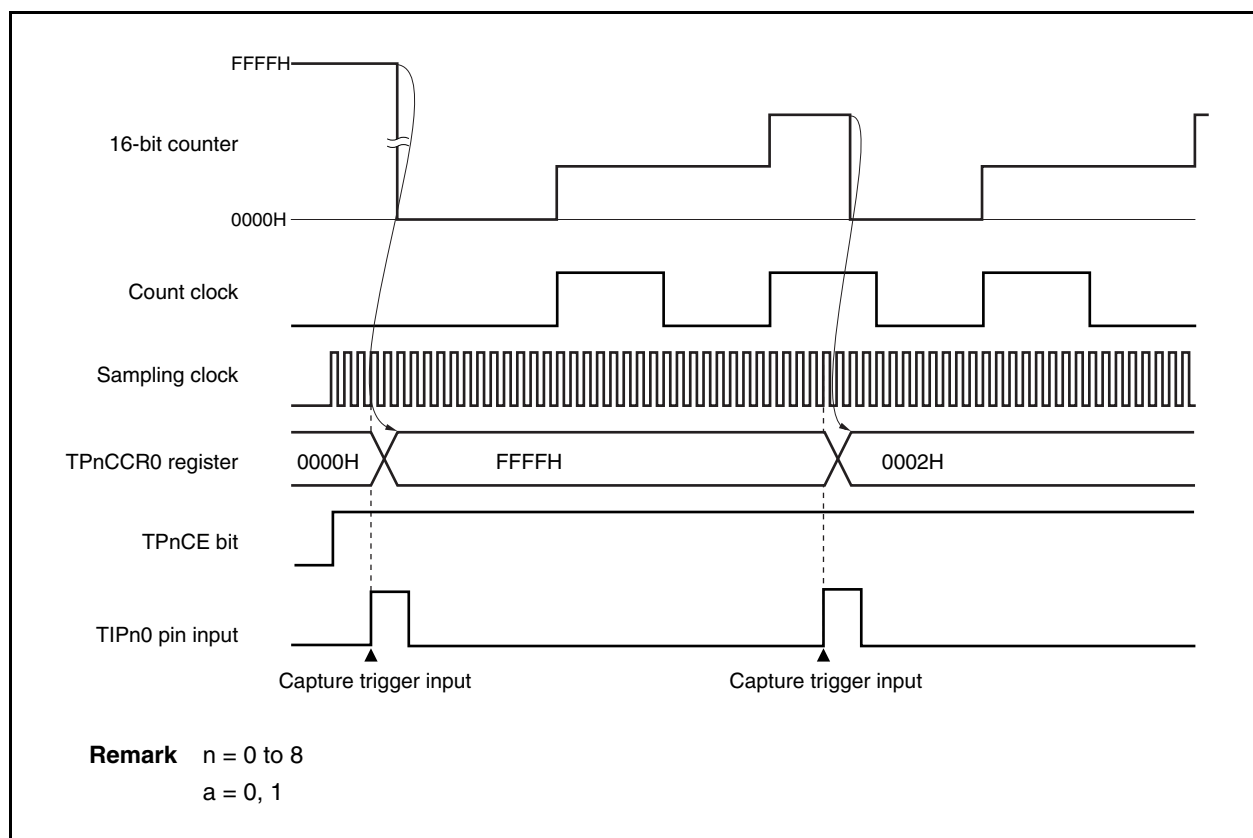

### 7.6.8 Encoder count function (only for TMP7 and TMP8)

The encoder count function includes an encoder compare mode (see 7.6.9 Encoder compare mode (TPmMD3 to TPmMD0 bits = 1000)).

Mode	TPmCCR0 Register	TPmCCR1 Register
Encoder compare mode	Compare only	Compare only

#### (1) Count-up/-down control

Counting up or down by the 16-bit counter is controlled by the phase of input encoder signals (TENCm0 and TENCm1) and setting of the TPmCTL2.TPmUDS1 and TPmCTL2.TPmUDS0 bits.

When the encoder count function is used, the internal count clock and external event count input (TIPm0) cannot be used. Set the TPmCTL0.TPmCKS2 to TPmCTL0.TPmCKS0 bits to 000 and the TPmCTL1.TPmEEE bit to 0.

#### (2) Setting initial value of 16-bit counter

The initial count value set to the TPmTCW register when the TPmCTL2.TPmECC bit = 0 is transferred to the 16-bit counter immediately after the counter starts its operation (TPmCTL0.TPmCE bit = 0 → 1), and the counter starts the operation after it detects the valid edge of the encoder input signal (TENCm0 or TENCm1).

#### (3) Basic operation

The TPmCCR<sub>a</sub> register generates a compare match interrupt request signal (INTTPmCC<sub>a</sub>) when the count value of the 16-bit counter matches the value of the CCR<sub>a</sub> buffer register.

#### (4) Clear operation

The 16-bit counter is cleared when the following conditions are satisfied in the encoder compare mode.

- When the value of the 16-bit counter matches the value of the compare register (the TPmCTL2.TPmECM1 and TPmCTL2.TPmECM0 bits are set)
- When the edge of the encoder clear input signal (TECR<sub>m</sub>) is detected and cleared (the TPmECS1 and TPmECS0 bits are set when the TPmIOC3.TPmSCE bit = 0)
- When the clear level condition of the TENCm0, TENCm1, and TECR<sub>m</sub> pins is detected (the TPmZCL, TPmBCL, and TPmACL bits are set when the TPmSCE bit = 1)

**Remark** m = 7, 8  
a = 0, 1

**(5) Controlling bits of TPmCTL2 register**

The setting of the TPmCTL2 register in the encoder compare mode is shown below.

**Table 7-7. Setting of TPmCTL2 Register**

Mode	TPmUDS1, TPmUDS0 Bits (<1>)	TPmECM1 Bit (<2>)	TPmECM0 Bit (<2>)	TPmLDE Bit (<3>)	Counter Clear (Target Compare Register)	Transfer to Counter
Encoder compare mode	Can be set to 00, 01, 10, or 11.	0	0	0	–	–
				1		Possible
		1	0	0	TPmCCR0	–
				1		Possible <sup>Note</sup>
		1	0	Invalid	TPmCCR1	–
				1		Invalid

**Note** The counter can operate in a range from 0000H to the set value of the TPmCCR0 register.

**Remark** m = 7, 8

**(a) Outline of each bit**

- <1> The TPmUDS1 and TPmUDS0 bits identify the counting direction (up or down) of the 16-bit counter by the phase input from the encoder input pin (TENCm0 or TENCm1).
- <2> The TPmECM1 and TPmECM0 bits control clearing of the 16-bit counter when its count value matches the value of the CCR0 or CCR1 buffer register.
- <3> The TPmLDE bit controls a function to transfer the set value of the TPmCCR0 register to the 16-bit counter when the counter underflows. The TPmLDE bit is valid only when the TPmECM1 and TPmECM0 bits are 00 or 01. It is invalid when these bits are set to any other value.



**(b) Detailed explanation of each bit**

<1> TPmUDS1 and TPmUDS0 bits: Count-up/-down selection

Whether the 16-bit counter is counting up or down is identified by the phase input from the TENCm0 or TENCm1 pin and depending on the setting of the TPmUDS1 and TPmUDS0 bits. These bits are valid only in the encoder compare mode.

- When TPmUDS1 and TPmUDS0 bits = 00

TENCm0 Pin	TENCm1 Pin	Count Operation
Rising edge	High level	Count down
Falling edge		
Both edges		
Rising edge	Low level	Count up
Falling edge		
Both edges		

**Remark** Detecting the edge of the TENCm0 pin is specified by the TPmIOC3.TPmEIS1 and TPmEIS0 bits.

**Figure 7-44. Operation Example (When Valid Edge of TENCm0 Pin Is Specified to Be Rising Edge and No Edge Is Specified as Valid Edge of TENCm1 Pin)**

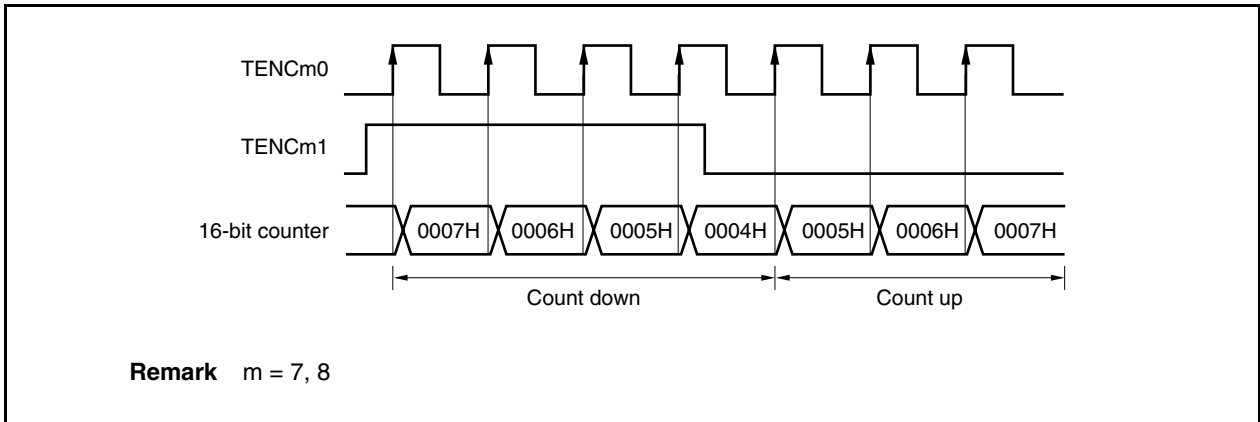

**Remark** m = 7, 8

- When TPmUDS1 and TPmUDS0 bits = 01

TENCM0 Pin	TENCM1 Pin	Count Operation
Low level	Rising edge	Count down
	Falling edge	
	Both edges	
High level	Rising edge	
	Falling edge	
	Both edges	
Rising edge	High level	Count up
Falling edge		
Both edges		
Rising edge	Low level	
Falling edge		
Both edges		
Simultaneous input to TENCM0 and TENCM1 pins		Counter does not perform count operation but holds value immediately before.

**Remark** Detecting the edge of the TENCM0 pin is specified by the TPmIOC3.TPmEIS1 and TPmIOC3.TPmEIS0 bits.

**Figure 7-45. Operation Example (When Rising Edge Is Specified as Valid Edge of TENCM0 and TENCM1 Pins)**

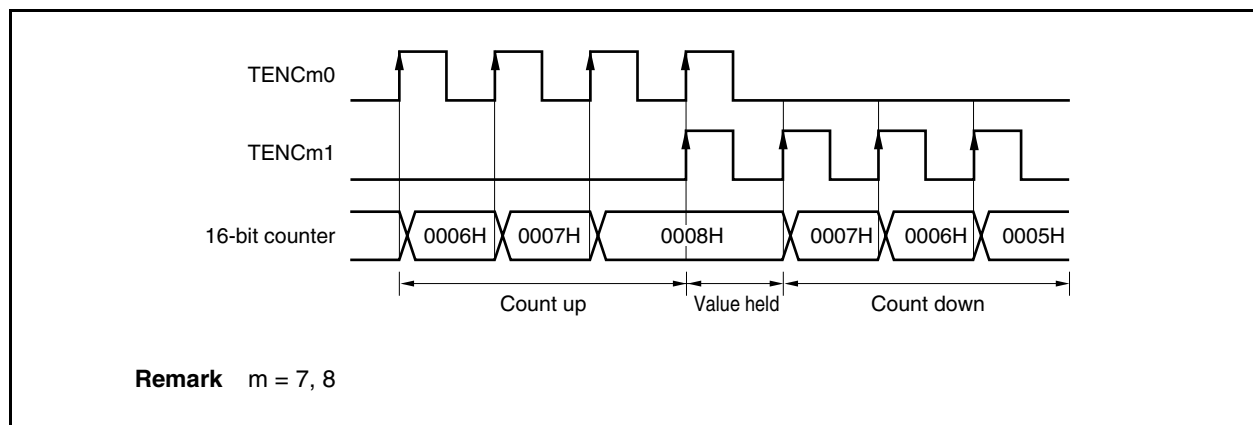

- When TPmUDS1 and TPmUDS0 bits = 10

TENCM0 Pin	TENCM1 Pin	Count Operation
Low level	Falling edge	Counter does not perform count operation but holds value immediately before.
Rising edge	Low level	Count down
High level	Rising edge	Counter does not perform count operation but holds value immediately before.
Falling edge	High level	
Rising edge	High level	
High level	Falling edge	
Falling edge	Low level	Count up
Low level	Rising edge	Counter does not perform count operation but holds value immediately before.
Rising edge	Rising edge	
Falling edge	Rising edge	
Rising edge	Falling edge	Count down
Falling edge	Falling edge	Count up

**Caution** Specification of the valid edge of the TENCM0 and TENCM1 pins is invalid.

Figure 7-46. Operation Example (Count Operation When Valid Edges of TENCM0 and TENCM1 Pins do not Overlap)

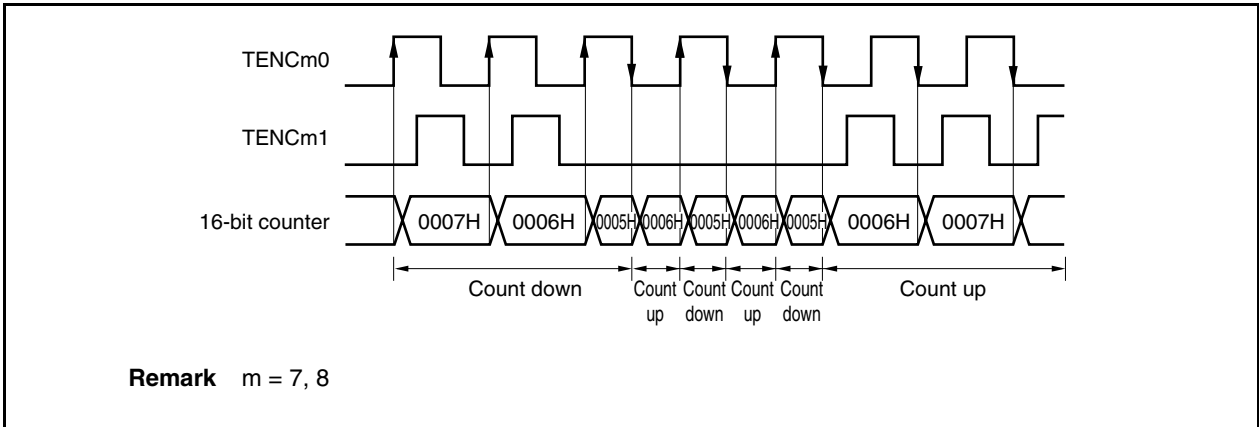

**Remark** m = 7, 8

Figure 7-47. Operation Example (Count Operation When Valid Edges of TENCM0 and TENCM1 Pins Overlap)

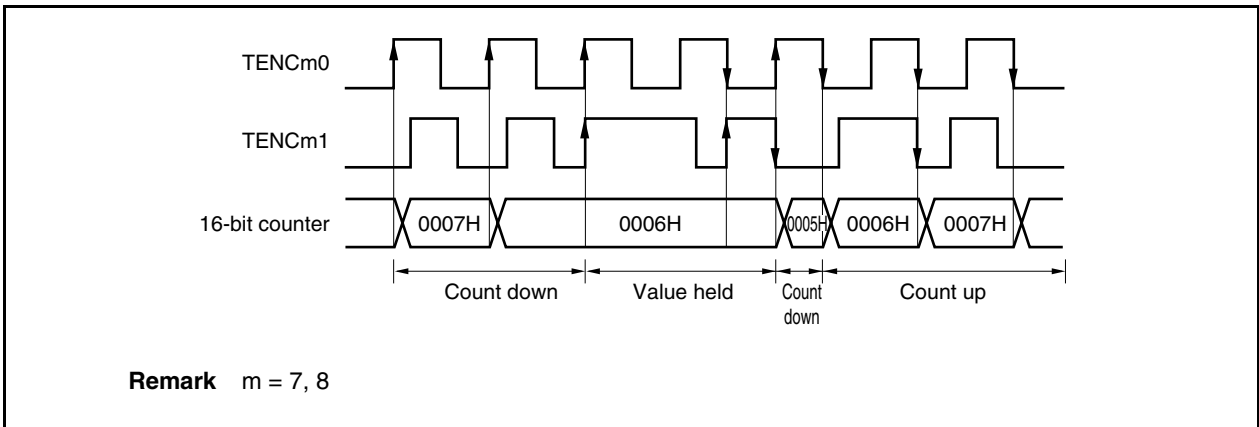

**Remark** m = 7, 8

- When TPmUDS1 and TPmUDS0 bits = 11

TENCM0 Pin	TENCM1 Pin	Count Operation
Low level	Falling edge	Count down
Rising edge	Low level	
High level	Rising edge	
Falling edge	High level	
Rising edge		Count up
High level	Falling edge	
Falling edge	Low level	
Low level	Rising edge	
Simultaneous input to TENCM0 and TENCM1 pins		Counter does not perform count operation but holds value immediately before.

**Caution** Specification of the valid edge of the TENCM0 and TENCM1 pins is invalid.

Figure 7-48. Operation Example (Count Operation When Valid Edges of TENCM0 and TENCM1 Pins do not Overlap)

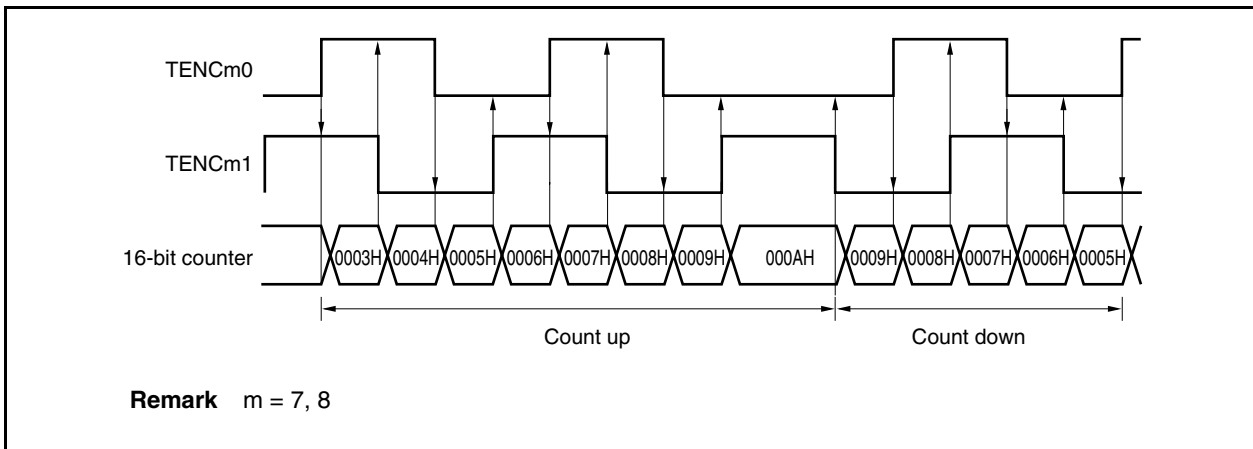
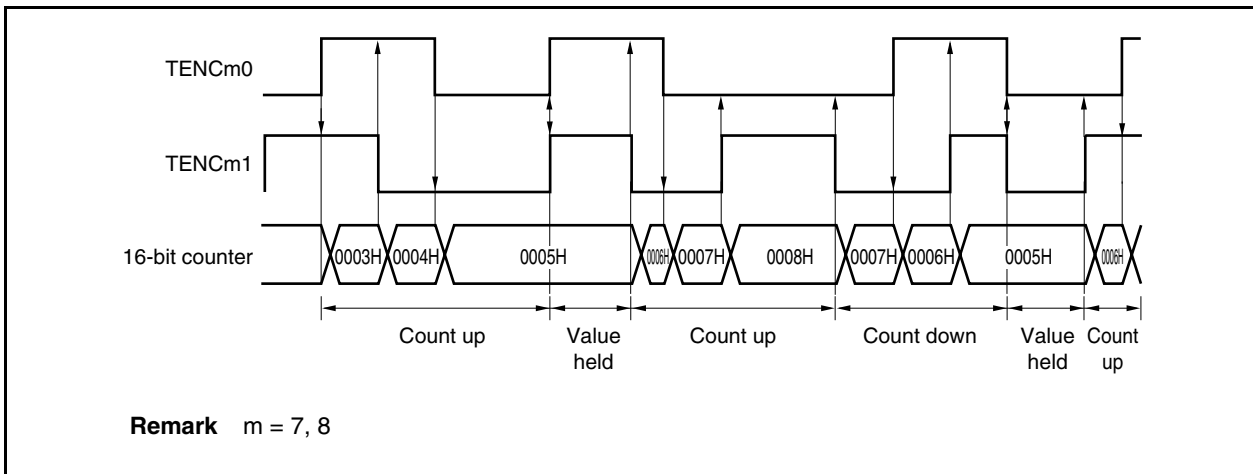

Figure 7-49. Operation Example (Count Operation When Valid Edges of TENCM0 and TENCM1 Pins Overlap)



<2> TPmECM1 and TPmECM0 bits: Timer/counter clear function upon match of the compare register  
 The 16-bit counter performs its count operation in accordance with the set value of the TPmECM1 and TPmECM0 bits when the count value of the counter matches the value of the CCRa buffer register.

- When TPmECM1 and TPmECM0 bits = 00  
 The 16-bit counter is not cleared when its count value matches the value of the CCRa buffer register.
- When TPmECM1 and TPmECM0 bits = 01  
 The 16-bit counter performs a count operation under the following condition when its count value matches the value of the CCR0 buffer register.

Next Count Operation	Description
Count up	16-bit counter is cleared to 0000H.
Count down	Count value of 16-bit counter is counted down.

- When TPmECM1 and TPmECM0 bits = 10  
 The 16-bit counter performs a count operation under the following condition when its count value matches the value of the CCR1 buffer register.

Next Count Operation	Description
Count up	Count value of 16-bit counter is counted up.
Count down	16-bit counter is cleared to 0000H.

- When TPmECM1 and TPmECM0 bits = 11  
 The 16-bit counter performs a count operation under the following condition when its count value matches the value of the CCR0 buffer register.

Next Count Operation	Description
Count up	16-bit counter is cleared to 0000H.
Count down	Count value of 16-bit counter is counted down.

The 16-bit counter performs a count operation under the following condition when its count value matches the value of the CCR1 buffer register.

Next Count Operation	Description
Count up	Count value of 16-bit counter is counted up.
Count down	16-bit counter is cleared to 0000H.

<3> TPmLDE bit: Transfer function of the set value of the TPmCCR0 register to the 16-bit counter when the counter underflows

When the TPmLDE bit = 1, the set value of the TPmCCR0 register can be transferred to the 16-bit counter when the counter underflows.

The TPmLDE bit is valid only in the encoder compare mode.

- Count operation in range from 0000H to set value of the TPmCCR0 register

If the 16-bit counter performs a count operation when the TPmLDE bit = 1 and TPmECM1 and TPmECM0 bits = 01, and when the count value of the counter matches the set value of the CCR0 buffer register when the TPmECM0 bit = 1, the 16-bit counter is cleared to 0000H if the next count operation is counting up.

If the 16-bit counter underflows when the TPmLDE bit = 1, the set value of the TPmCCR0 register is transferred to the counter.

Therefore, the counter can operate in a range from 0000H to the set value of the TPmCCR0 register in which the upper-limit count value is the set value of the TPmCCR0 register and the lower-limit value is 0000H.

**Figure 7-50. Operation Example (Count Operation in Range from 0000H to Set Value of TPmCCR0 Register)**

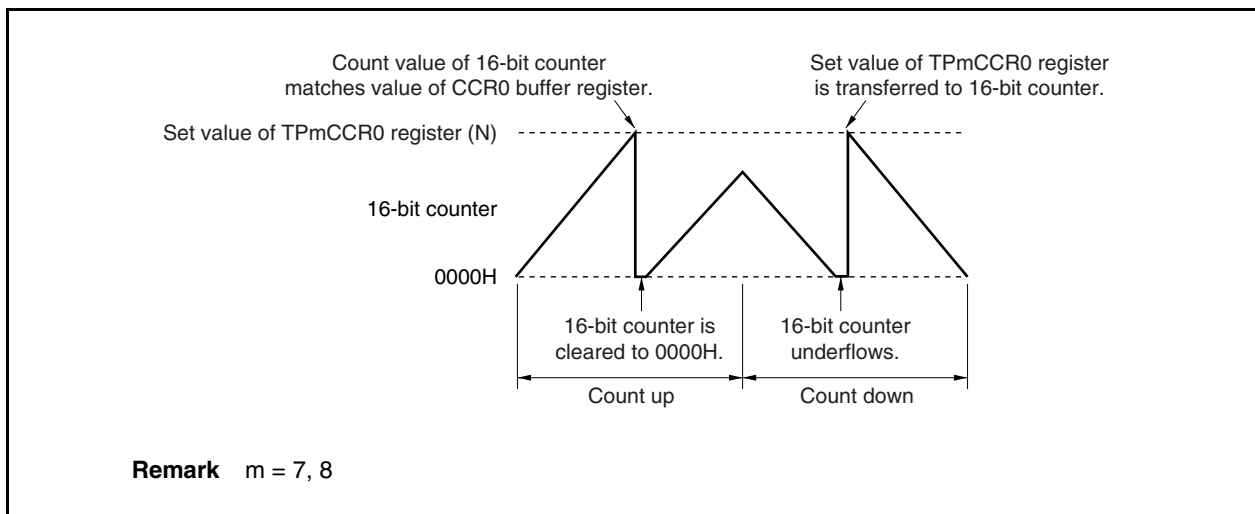
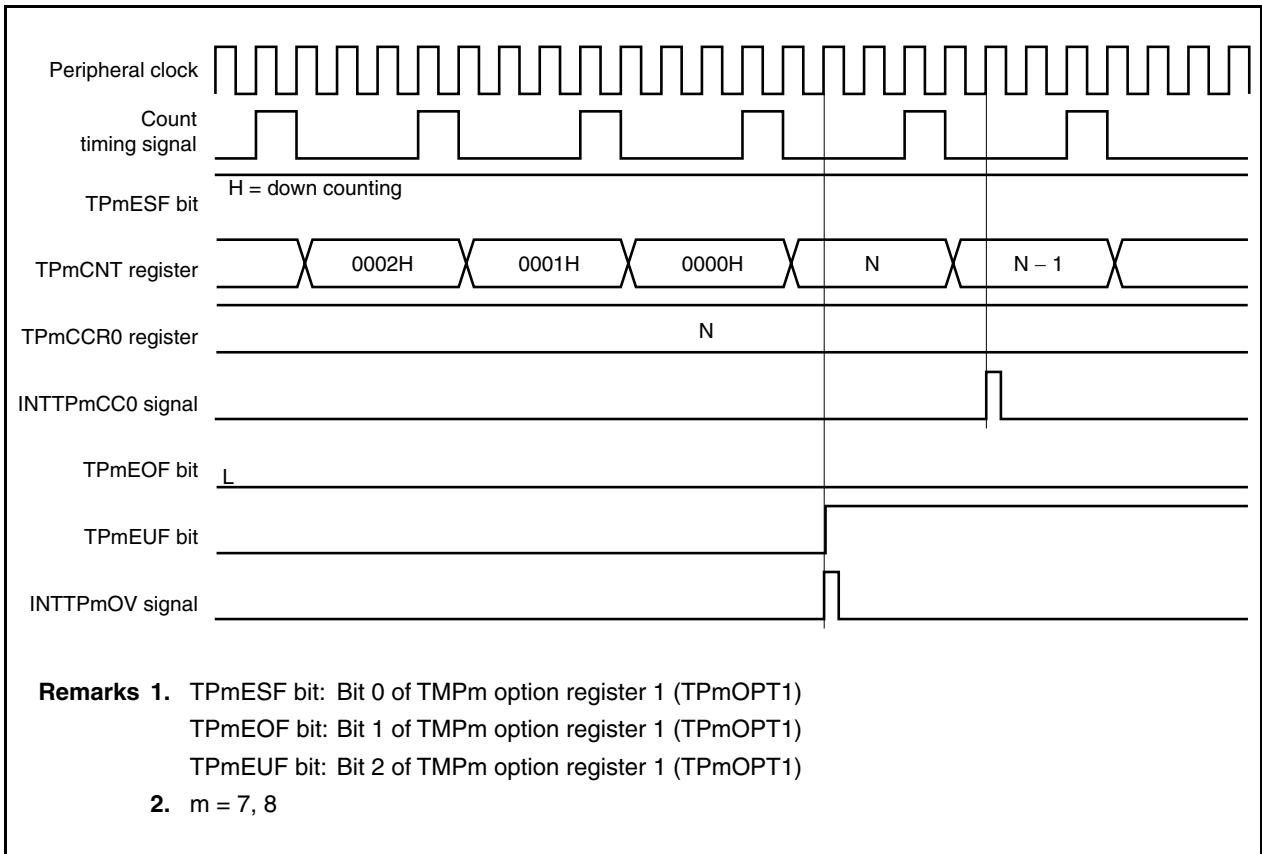

Figure 7-51. Operation Timing (Count Operation in Range from 0000H to Set Value of TPmCCR0 Register)



**(6) Clearing counter to 0000H by encoder clear signal (TECRm pin)**

The 16-bit counter can be cleared to 0000H by the input signal of the TECRm pin in two ways which are selected by the TPmIOC3.TPmSCE bit. The TPmSCE bit also controls, depending its setting, the TPmIOC3.TPmZCL, TPmIOC3.TPmBCL, TPmIOC3.TPmACL, TPmIOC3.TPmESC1, and TPmIOC3.TPmECS0 bits.

The counter can be cleared by the methods described below only in the encoder compare mode.

**Table 7-8. Relationship Between TPmSCE Bit and TPmZCL, TPmBCL, TPmACL, TPmESC1, and TPmECS0 Bits**

Clearing Method	TPmSCE Bit	TPmZCL Bit	TPmBCL Bit	TPmACL Bit	TPmESC1, TPmECS0 Bits
<1>	0	Invalid	Invalid	Invalid	Valid
<2>	1	Valid	Valid	Valid	Invalid

**(a) Clearing method <1>: By detecting edge of encoder clear signal (TECRm pin) (TPmSCE bit = 0)**

When the TPmSCE bit = 0, the 16-bit counter is cleared to 0000H in synchronization with the peripheral clock if the valid edge of the TECRm pin specified by the TPmESC1 and TPmECS0 bits is detected. At this time, an encoder clear interrupt request signal (INTTIECm) is generated. When the TPmSCE bit = 0, setting of the TPmZCL, TPmBCL, and TPmACL bits is invalid.

**Figure 7-52. Operation Example (When TPmSCE Bit = 0, TPmESC1 and TPmECS0 Bits = 01, and TPmUDS1 and TPmUDS0 Bits = 11)**

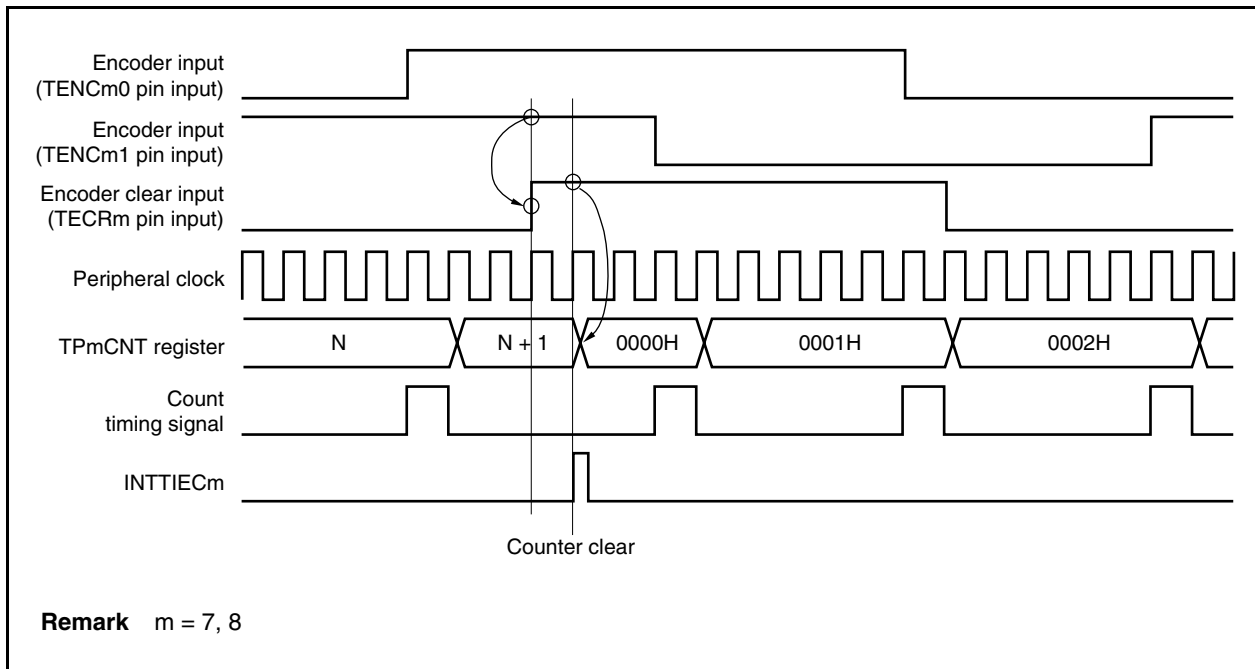



**(b) Clearing method <2>: By detecting clear level condition of the TENCm0, TENCm1, and TECRm pins (TPmSCE bit = 1)**

When the TPmSCE bit = 1, the 16-bit counter is cleared to 0000H if the clear level condition of the TECRm, TENCm0, or TENCm1 pin specified by the TPmZCL, TPmBCL, and TPmACL bits is detected. At this time, the encoder clear interrupt request signal (INTTIECm) is not generated. Setting of the TPmECS1 and TPmECS0 bits is invalid when the TPmSCE bit = 1.

**Table 7-9. 16-bit Counter Clearing Condition When TPmSCE Bit = 1**

Clear Level Condition Setting			Input Level of Encoder Pin		
TPmZCL Bit	TPmBCL Bit	TPmACL Bit	TECRm Pin	TENCm1 Pin	TENCm0 Pin
0	0	0	L	L	L
0	0	1	L	L	H
0	1	0	L	H	L
0	1	1	L	H	H
1	0	0	H	L	L
1	0	1	H	L	H
1	1	0	H	H	L
1	1	1	H	H	H

**Caution** The 16-bit counter is cleared to 0000H when the clear level condition of the TPmZCL, TPmBCL, and TPmACL bits match the input level of the TECRm, TENCm1, or TENCm0 pin.

**Remark** m = 7, 8

**Figure 7-53. Operation Example (When TPmSCE Bit = 1, TPmZCL Bit = 1, TPmBCL Bit = 0, TPmACL Bit = 1, TPmUDS1 and TPmUDS0 Bits = 11, TECRm = High Level, TENCm1 = Low Level, and TENCm0 = High Level) (1/3)**

(i) If inputting the high level to the TECRm pin lags behind inputting the low level to the TENCm1 pin while the counter is counting up, the counter is cleared after it counts up.

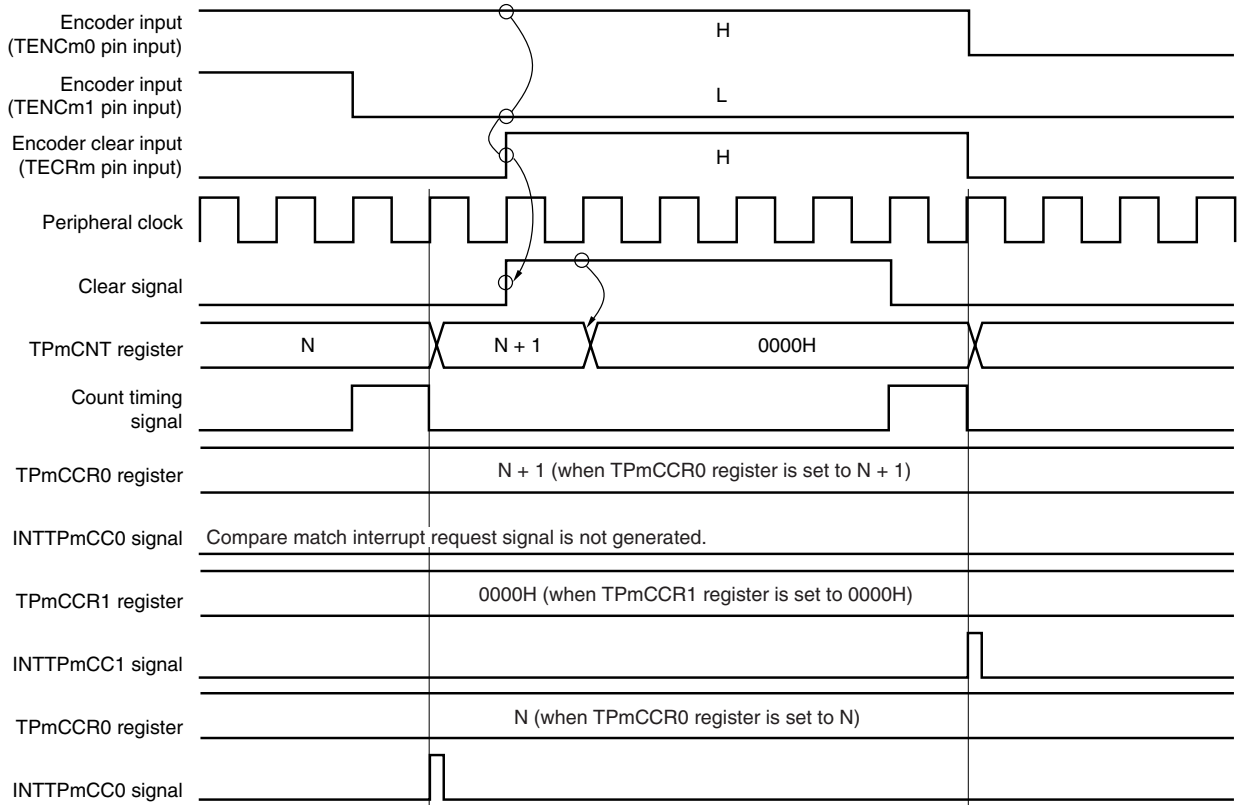

**Remark** m = 7, 8

**Figure 7-53. Operation Example (When TPmSCE Bit = 1, TPmZCL Bit = 1, TPmBCL Bit = 0, TPmACL Bit = 1, TPmUDS1 and TPmUDS0 Bits = 11, TECRm = High Level, TENCm1 = Low Level, and TENCm0 = High Level) (2/3)**

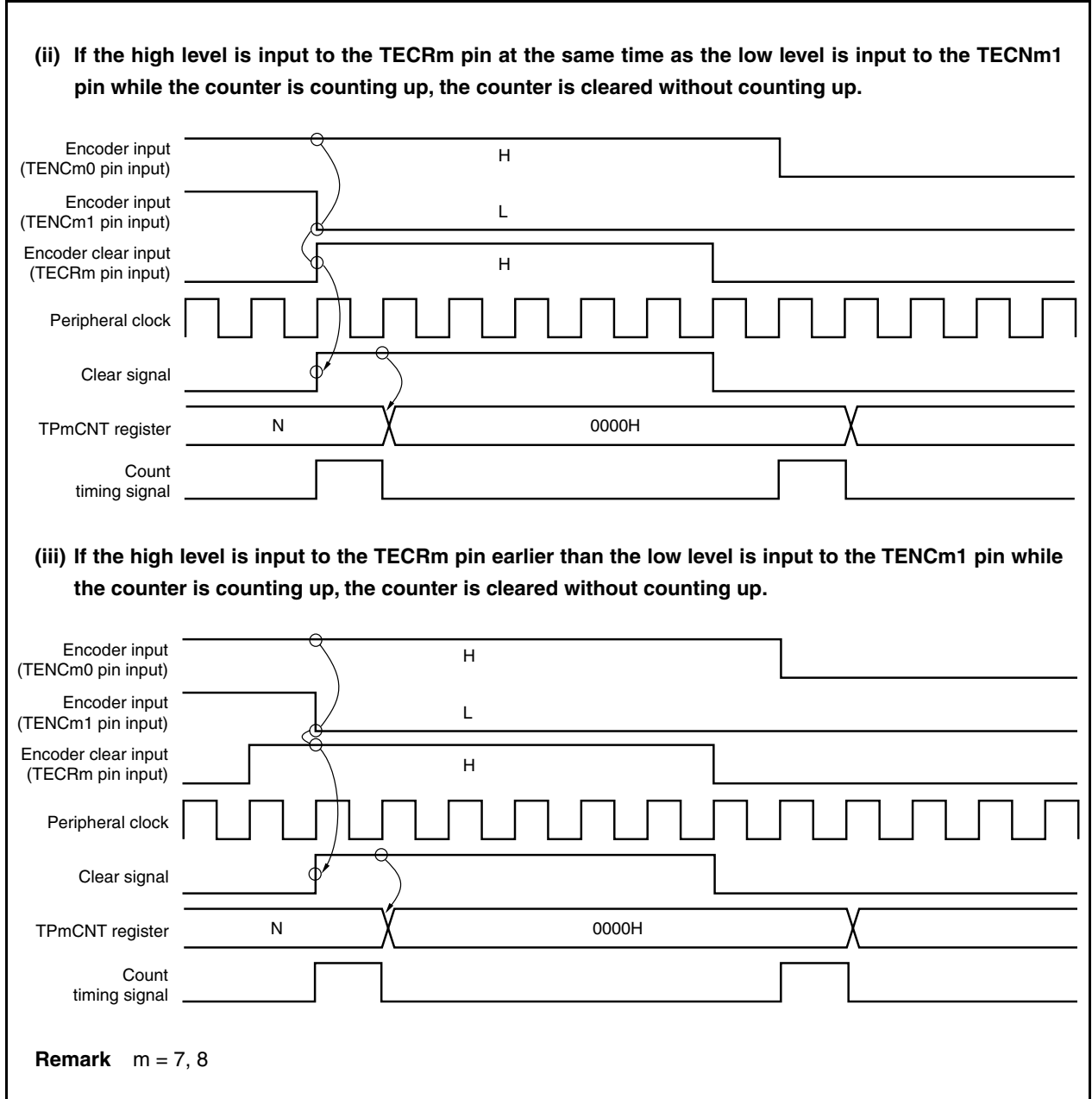

**Figure 7-53. Operation Example (When TPmSCE Bit = 1, TPmZCL Bit = 1, TPmBCL Bit = 0, TPmACL Bit = 1, TPmUDS1 and TPmUDS0 Bits = 11, TECRm = High Level, TENCm1 = Low Level, and TENCm0 = High Level) (3/3)**

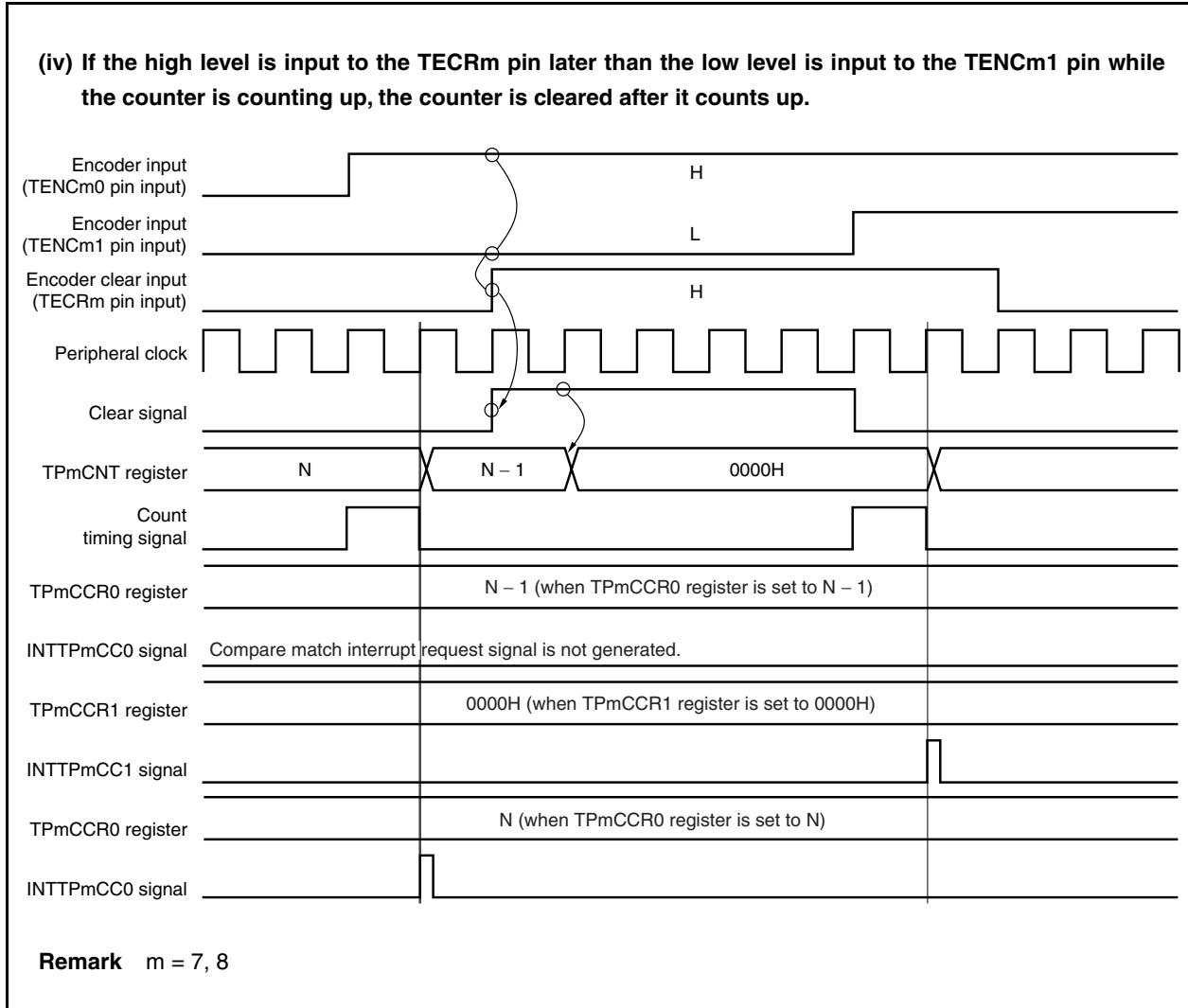

If the counter is cleared in this way, a miscount does not occur even if inputting the signal to the TECRm pin is late, because the clear level condition of the TECRm, TENCm1, and TENCm0 pins is set and the 16-bit counter is cleared to 0000H when the clear level condition is detected.

**7.6.9 Encoder compare mode (TPmMD3 to TPmMD0 bits = 1000)**

In the encoder compare mode, the encoder is controlled by using both the TPmCCR0 and TPmCCR1 registers as compare registers and the input pins for encoder count function (TENCm0, TENCm1, and TECRm).

In this mode, the 16-bit counter can be cleared to 0000H in three ways: when the count value of the counter matches the value of the CCRa buffer register (compare match interrupt request signal (INTTPmCCa) is generated), when the edge of the encoder clear input (TECRm pin) is detected and cleared, and when the clear level condition of TENCm0, TENCm1, and TECRm pins is detected and cleared.

When the 16-bit counter underflows, the set value of the TPmCCR0 register can be transferred to the counter.

**(1) Encoder compare mode operation flow**

**Figure 7-54. Encoder Compare Mode Operation Flow**

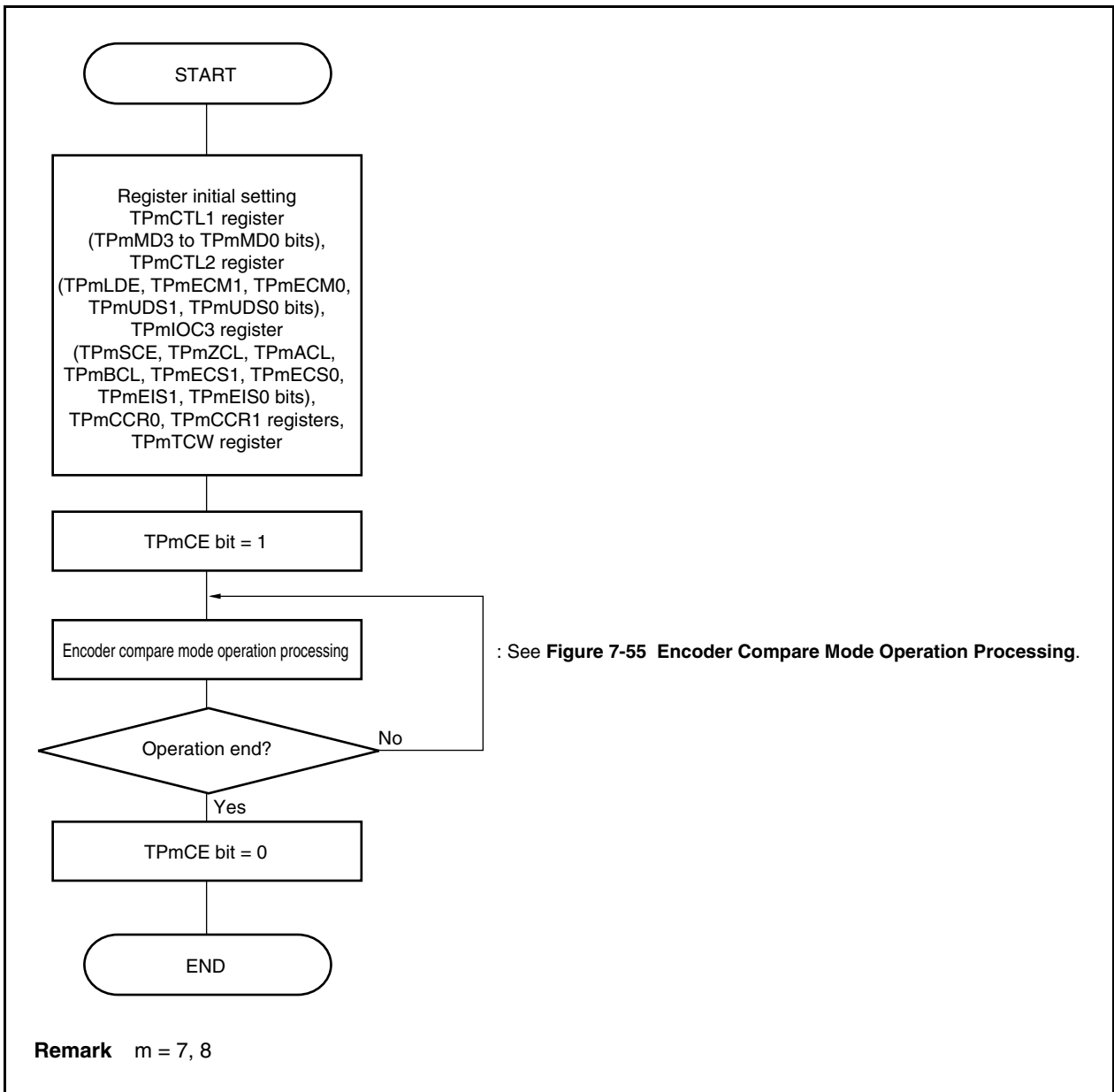
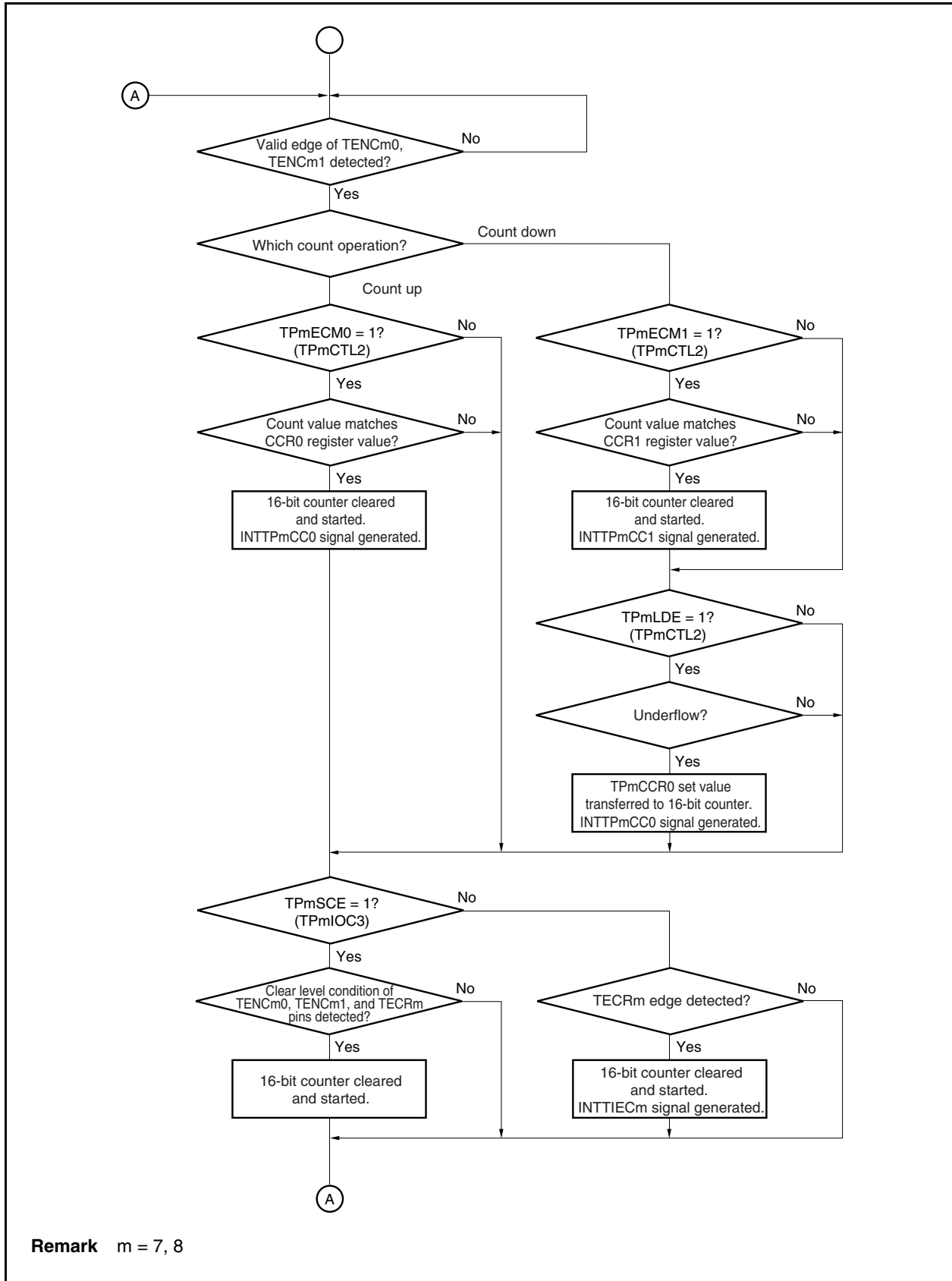

Figure 7-55. Encoder Compare Mode Operation Processing



Remark m = 7, 8

(2) Encoder compare mode operation timing

(a) Basic timing 1

[Register setting conditions]

- TPmCTL2.TPmECM1 and TPmCTL2.TPmECM0 bits = 01  
The 16-bit counter is cleared to 0000H when its count value matches the value of the CCR0 buffer register.
- TPmCTL2.TPmLDE bit = 1  
The set value of the TPmCCR0 register is transferred to the 16-bit counter when it overflows.
- TPmIOC3.TPmSCE bit = 0, and TPmIOC3.TPmECS1 and TPmIOC3.TPmECS0 bits = 00  
Specification of the edge of encoder clear input signal (TECRm pin) to be detected and cleared (no edge specified)

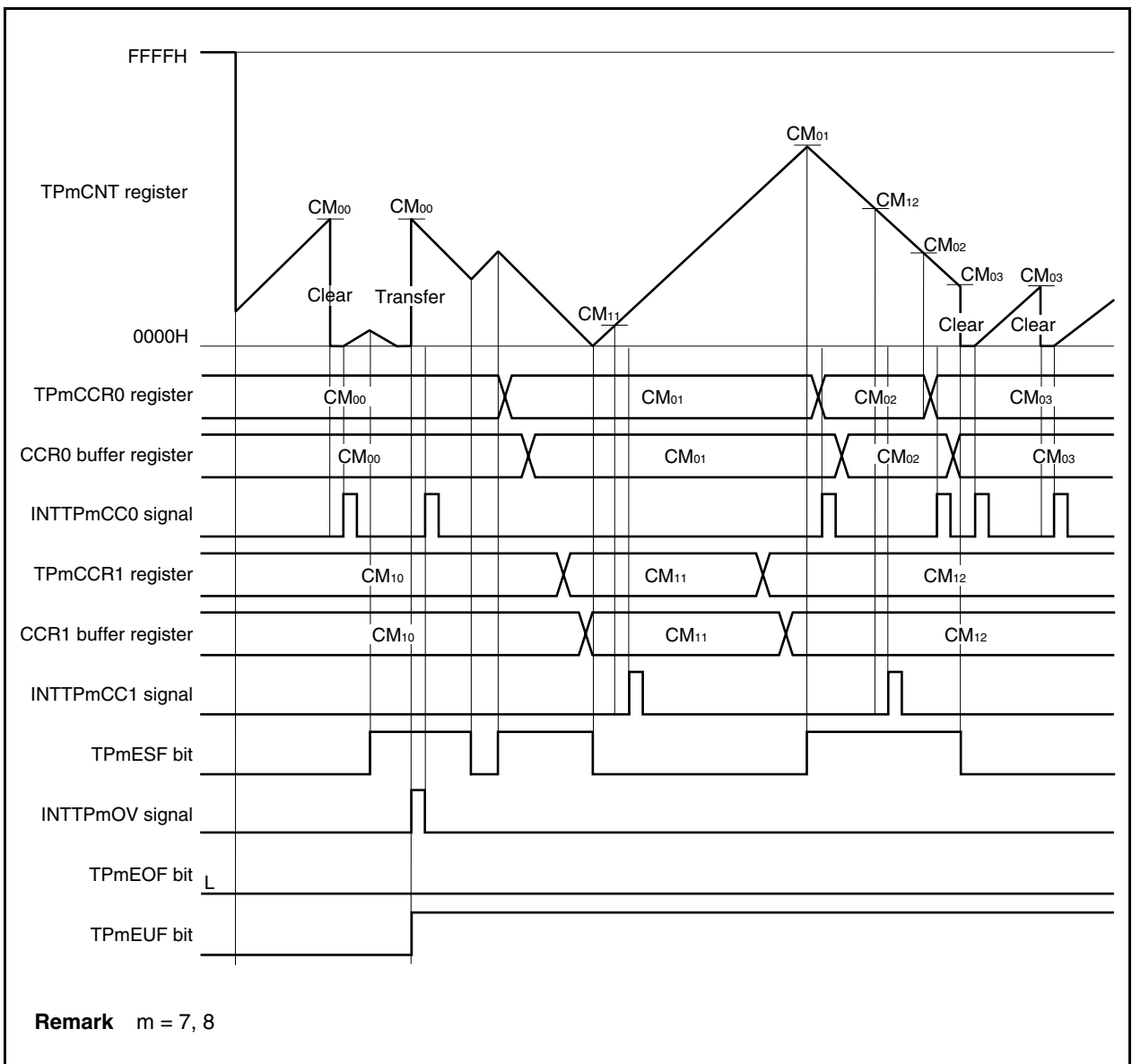

When the 16-bit counter starts operating (TPmCE bit = 0 → 1), the set value of the TPmTCW register is transferred to the counter and the 16-bit counter starts operating.

When the count value of the counter matches the value of the CCR0 buffer register, the compare match interrupt request signal (INTTPmCC0) is generated. Because the TPmECM0 bit = 1, the 16-bit counter is cleared to 0000H if the next count operation is counting up.

When the count value of the 16-bit counter matches the value of the CCR1 buffer register, the compare match interrupt request signal (INTTPmCC1) is generated. Because the TPmECM1 bit = 0, the 16-bit counter is not cleared to 0000H when its value matches that of the CCR1 buffer register.

When the TPmLDE bit = 1 and TPmECM0 bit = 1, the counter can operate in a range from 0000H to the set value of the TPmCCR0 register.



**(b) Basic timing 2**

**[Register setting condition]**

- TPmCTL2.TPmECM1 and TPmCTL2.TPmECM0 bits = 00  
The 16-bit counter is not cleared even when its count value matches the value of the CCRa buffer register (a = 0, 1).
- TPmCTL2.TPmLDE bit = 0  
The set value of the TPmCCR0 register is not transferred to the 16-bit counter after the counter underflows.
- TPmIOC3.TPmSCE bit = 0, and TPmIOC3.TPmECS1 and TPmIOC3.TPmECS0 bits = 00  
Specification of the edge of the encoder clear input signal (TECRm pin) to be detected and cleared (no edge specified)

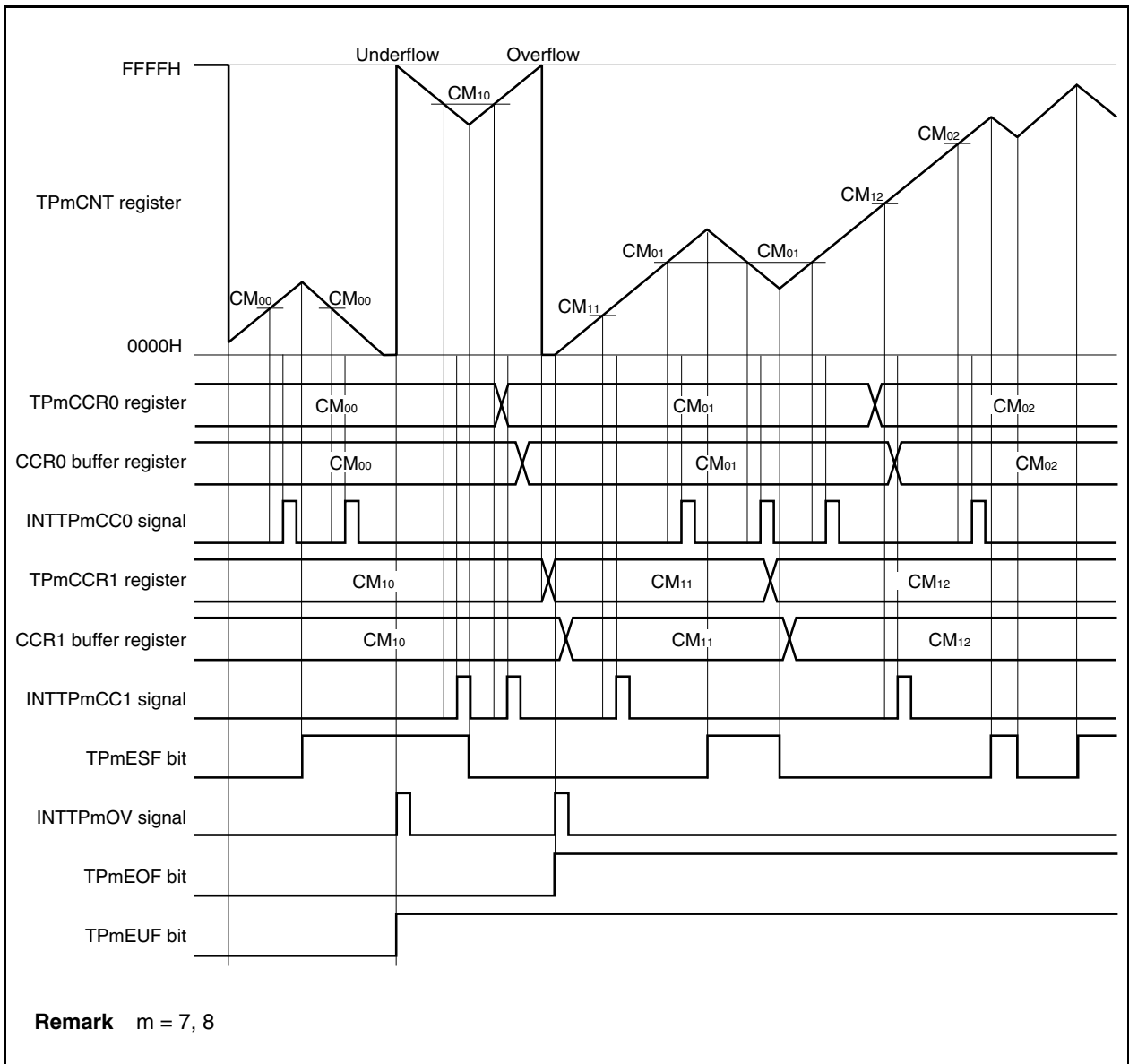

When the 16-bit counter starts operating (TPmCE bit = 0 → 1), the set value of the TPmTCW register is transferred to the 16-bit counter and the counter starts operating.

When the count value of the 16-bit counter matches the value of the CCR0 buffer register, a compare match interrupt request signal (INTTPmCC0) is generated.

When the count value of the 16-bit counter matches the value of the CCR1 buffer register, a compare match interrupt request signal (INTTPmCC1) is generated.

The 16-bit counter is not cleared to 0000H even when its count value matches the value of the CCRa buffer register because the TPmECM1 and TPmECM0 bits = 00 (a = 0, 1).

(c) Basic timing 3

[Register setting condition]

- TPmCTL2.TPmECM1 and TPmCTL2.TPmECM0 bits = 11  
 The count value of the 16-bit counter is cleared to 0000H when its value matches the value of the CCR0 buffer register.  
 The count value of the 16-bit counter is cleared to 0000H when its value matches the value of the CCR1 buffer register.
- Setting of the TPmCTL2.TPmLDE bit is invalid.
- TPmIOC3.TPmSCE bit = 0, and TPmIOC3.TPmECS1 and TPmIOC3.TPmECS0 bits = 00  
 Specification of the edge of the encoder clear input signal (TECRm pin) to be detected and cleared (no edge specified)

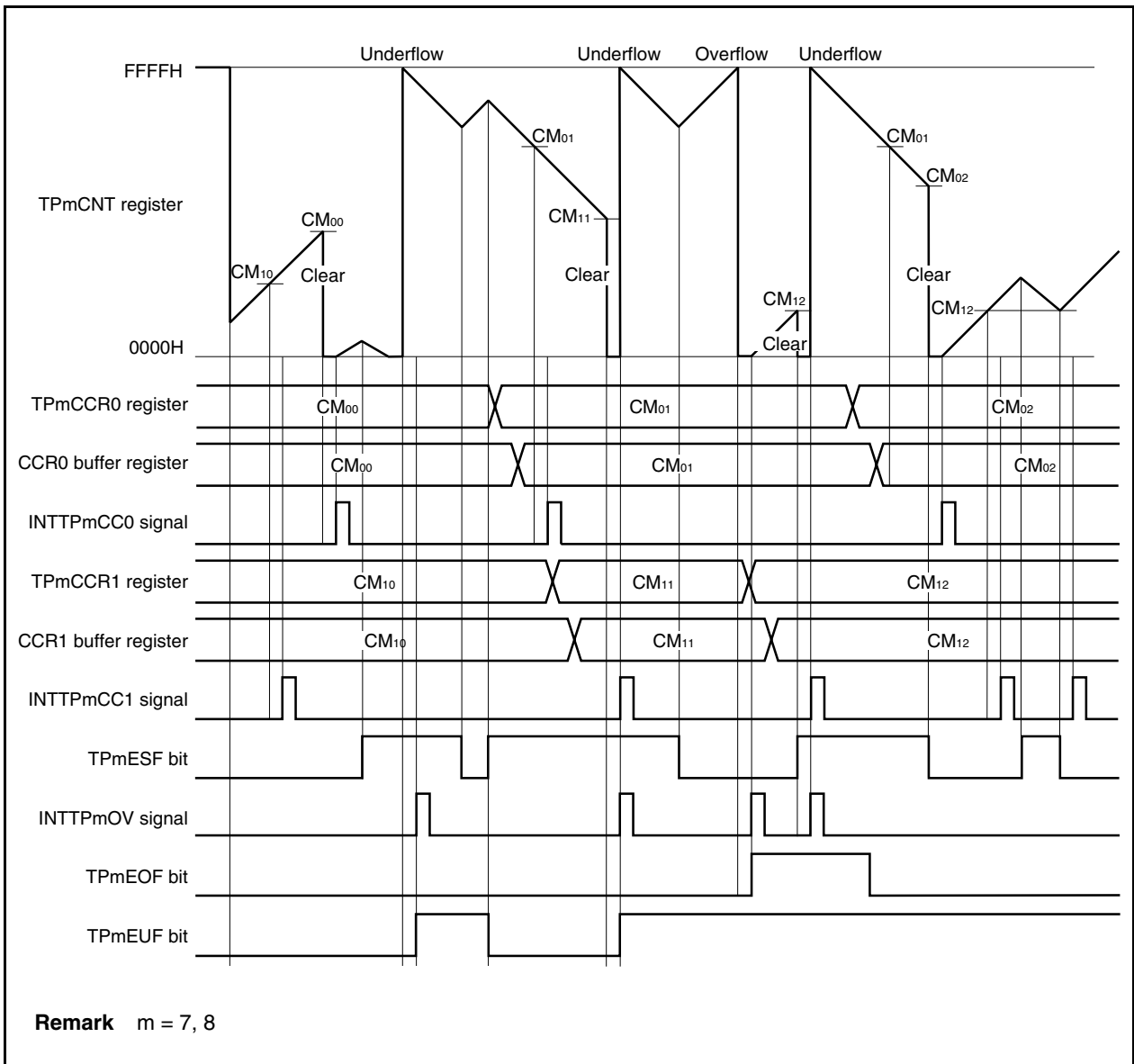

When the 16-bit counter starts operating (TPmCE bit = 0 → 1), the set value of the TPmTCW register is transferred to the 16-bit counter and the counter starts operating.

When the count value of the 16-bit counter matches the value of the CCR0 buffer register, a compare match interrupt request signal (INTTPmCC0) is generated. At this time, the 16-bit counter is cleared to 0000H if the next count operation is counting up.

When the count value of the 16-bit counter matches the value of the CCR1 buffer register, a compare match interrupt request signal (INTTPmCC1) is generated. At this time, the 16-bit counter is cleared to 0000H if the next count operation is counting down.

## 7.7 Selector Function

In the V850E/SJ3-H and V850E/SK3-H, the TIP input or RXDA input and the TIQ input or TSOUT signal<sup>Note</sup> can be selected as the capture trigger input of TMP and TMQ, respectively.

By using this function, the following is possible.

- The TIQ02 and TIQ03 input signals of TMQ0 can be selected from the port/timer alternate-function pins (TIQ02 and TIQ03 pins) and the TSOUT signal<sup>Note</sup> of the CAN controller.  
→ If the TSOUT signal of CAN0 or CAN1 is selected, the time stamp function of the CAN controller can be used.
- The TIP10 and TIP11 input signals of TMP1 can be selected from the port/timer alternate-function pins (TIP10 and TIP11 pins) and the UARTA reception alternate-function pins (RXDA0 and RXDA1). The TIP31 input signal of TMP3 can be selected from a port/timer alternate-function pin (TIP31 pin) and the UARTA reception alternate-function pin (RXDA3).  
→ When the RXDA0, RXDA1, or RXDA3 signal of UART0, UART1, or UART3 is selected, the LIN reception transfer rate and baud rate error of UARTA can be calculated.

- Cautions**
1. When using the selector function, set the capture trigger input of TMP or TMQ before connecting the timer.
  2. When setting the selector function, first disable the peripheral I/O to be connected (TMP/UARTA or TMQ/CAN controller<sup>Note</sup>).

**Note** CAN controller versions only

The capture trigger input for the selector function is specified by the following register.

**(1) Selector operation control register 0 (SELCNT0)**

The SELCNT0 register is an 8-bit register that selects the capture trigger for TMP1, TMP3, and TMQ0.

This register can be read or written in 8-bit or 1-bit units.

Reset sets this register to 00H.

After reset: 00H    R/W    Address: FFFFF308H

	7	<6>	5	<4>	<3>	2	<1>	<0>
SELCNT0	0	ISEL6	0	ISEL4	ISEL3	0	ISEL1 <sup>Note 1</sup>	ISEL0 <sup>Note 2</sup>

ISEL6	Selection of TIP31 input signal (TMP3)
0	TIP31 pin input (alternate function of P94 pin)
1	RXDA3 pin input (alternate function of P80 pin)

ISEL4	Selection of TIP11 input signal (TMP1)
0	TIP11 pin input (alternate function of P35 pin)
1	RXDA1 pin input/KR3 pin input (alternate function of P91 or P150 <sup>Note 3</sup> pin)

ISEL3	Selection of TIP10 input signal (TMP1)
0	TIP10 pin input (alternate function of P34 pin)
1	RXDA0 pin input (alternate function of P31 pin)

ISEL1 <sup>Note 1</sup>	Selection of TIQ03 input signal (TMQ0)
0	TIQ03 pin input/KR2 pin input (alternate function of P52 or P65 pin)
1	TSOUT signal of CAN1

ISEL0 <sup>Note 2</sup>	Selection of TIQ02 input signal (TMQ0)
0	TIQ02 pin input (alternate function of P51 pin)
1	TSOUT signal of CAN0

- Notes**
1. The ISEL1 bit is available only in the CAN controller (2-channel) version.  
In other cases, be sure to clear this bit to 0.
  2. The ISEL0 bit is valid only for the CAN controller version.  
In other cases, be sure to clear this bit to 0.
  3. P150/RXDA1/KR7 is available only in the V850E/SK3-H.

**Caution** To set the ISEL0, ISEL1, ISEL3, ISEL4, and ISEL6 bits to 1, set the corresponding pin in the capture trigger input mode.

## 7.8 Cautions

### (1) DMA transfer start factors

In the V850E/SJ3-H and V850E/SK3-H, the DMA transfer start factors INTTP0OV signal and INTUB0TIT signal, INTTP1OV signal and INTUB1TIR signal, and INTTP2OV signal and INTUB1TIT signal are used alternately and cannot be used simultaneously. To use the INTTP0OV, INTTP1OV, or INTTP2OV signal as DMA transfer start factors, set the DTFROB0 bit in the option byte area 0000007AH to 0 (see **CHAPTER 33 OPTION BYTE FUNCTION**). In this case, the INTUB0TIT, INTUB1TIR, and INTUB1TIT signals cannot be used as a DMA transfer start factor.

**Remark** For details, see **Table 22-1 DMA Transfer Start Factors**.

## CHAPTER 8 16-BIT TIMER/EVENT COUNTER Q (TMQ)

Timer Q (TMQ) is a 16-bit timer/event counter.

The V850E/SJ3-H and V850E/SK3-H incorporate TMQ0.

### 8.1 Overview

An outline of TMQ0 is shown below.

- Clock selection: 8 ways
- Capture/trigger input pins: 4
- External event count input pin: 1
- External trigger input pin: 1
- Timer/counter: 1
- Capture/compare registers: 4
- Capture/compare match interrupt request signals: 4
- Overflow interrupt request signal: 1
- Timer output pins: 4

### 8.2 Functions

TMQ0 has the following functions.

- Interval timer
- External event counter
- External trigger pulse output
- One-shot pulse output
- PWM output
- Free-running timer
- Pulse width measurement



### 8.3 Configuration

TMQ0 includes the following hardware.

**Table 8-1. Configuration of TMQ0**

Item	Configuration
Timer register	16-bit counter
Registers	TMQ0 capture/compare registers 0 to 3 (TQ0CCR0 to TQ0CCR3) TMQ0 counter read buffer register (TQ0CNT) CCR0 to CCR3 buffer registers
Timer inputs	4 (TIQ00 <sup>Note 1</sup> to TIQ03 pins)
Timer outputs	4 (TOQ00 to TOQ03 pins)
Control registers <sup>Note 2</sup>	TMQ0 control registers 0, 1 (TQ0CTL0, TQ0CTL1) TMQ0 I/O control registers 0 to 2 (TQ0IOC0 to TQ0IOC2) TMQ0 option register 0 (TQ0OPT0)

- Notes 1.** The TIQ00 pin functions alternately as a capture trigger input signal, external event count input signal, and external trigger input signal.
- 2.** When using the functions of the TIQ00 to TIQ03 and TOQ00 to TOQ03 pins, refer to **Table 4-25 Using Port Pin as Alternate-Function Pin**.

Figure 8-1. Block Diagram of TMQ0

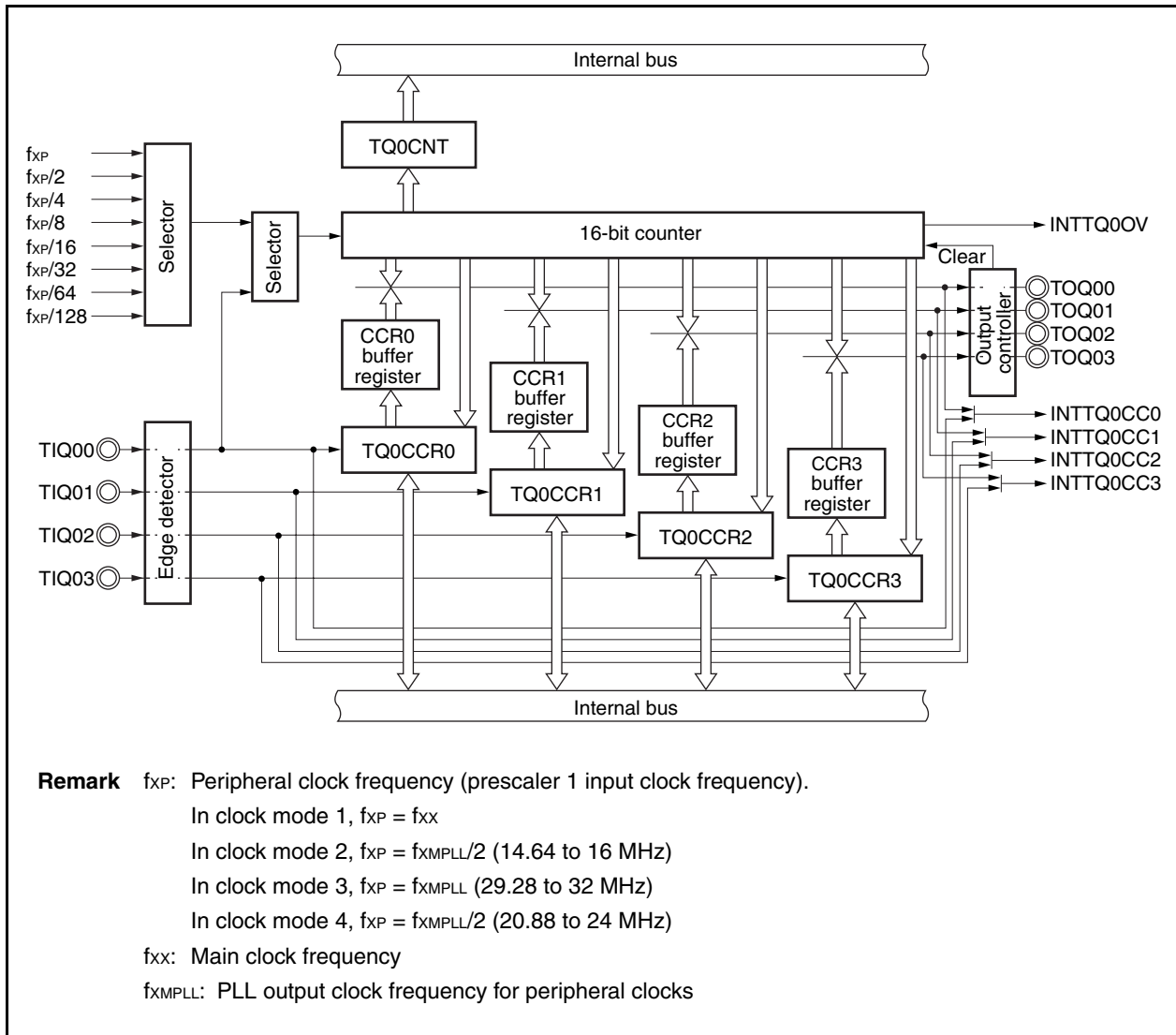
**(1) 16-bit counter**

This 16-bit counter can count internal clocks or external events.

The count value of this counter can be read by using the TQ0CNT register.

When the TQ0CTL0.TQ0CE bit = 0, the value of the 16-bit counter is FFFFH. If the TQ0CNT register is read at this time, 0000H is read.

Reset sets the TQ0CE bit to 0.

**(2) CCR0 buffer register**

This is a 16-bit compare register that compares the count value of the 16-bit counter.

When the TQ0CCR0 register is used as a compare register, the value written to the TQ0CCR0 register is transferred to the CCR0 buffer register. When the count value of the 16-bit counter matches the value of the CCR0 buffer register, a compare match interrupt request signal (INTTQ0CC0) is generated.

The CCR0 buffer register cannot be read or written directly.

The CCR0 buffer register is cleared to 0000H after reset, as the TQ0CCR0 register is cleared to 0000H.

**(3) CCR1 buffer register**

This is a 16-bit compare register that compares the count value of the 16-bit counter.

When the TQ0CCR1 register is used as a compare register, the value written to the TQ0CCR1 register is transferred to the CCR1 buffer register. When the count value of the 16-bit counter matches the value of the CCR1 buffer register, a compare match interrupt request signal (INTTQ0CC1) is generated.

The CCR1 buffer register cannot be read or written directly.

The CCR1 buffer register is cleared to 0000H after reset, as the TQ0CCR1 register is cleared to 0000H.

**(4) CCR2 buffer register**

This is a 16-bit compare register that compares the count value of the 16-bit counter.

When the TQ0CCR2 register is used as a compare register, the value written to the TQ0CCR2 register is transferred to the CCR2 buffer register. When the count value of the 16-bit counter matches the value of the CCR2 buffer register, a compare match interrupt request signal (INTTQ0CC2) is generated.

The CCR2 buffer register cannot be read or written directly.

The CCR2 buffer register is cleared to 0000H after reset, as the TQ0CCR2 register is cleared to 0000H.

**(5) CCR3 buffer register**

This is a 16-bit compare register that compares the count value of the 16-bit counter.

When the TQ0CCR3 register is used as a compare register, the value written to the TQ0CCR3 register is transferred to the CCR3 buffer register. When the count value of the 16-bit counter matches the value of the CCR3 buffer register, a compare match interrupt request signal (INTTQ0CC3) is generated.

The CCR3 buffer register cannot be read or written directly.

The CCR3 buffer register is cleared to 0000H after reset, as the TQ0CCR3 register is cleared to 0000H.

**(6) Edge detector**

This circuit detects the valid edges input to the TIQ00 and TIQ03 pins. No edge, rising edge, falling edge, or both the rising and falling edges can be selected as the valid edge by using the TQ0IOC1 and TQ0IOC2 registers.

**(7) Output controller**

This circuit controls the output of the TOQ00 to TOQ03 pins. The output controller is controlled by the TQ0IOC0 register.

**(8) Selector**

This selector selects the count clock for the 16-bit counter. Eight types of internal clocks or an external event can be selected as the count clock.

## 8.4 Registers

The registers that control TMQ0 are as follows.

- TMQ0 control register 0 (TQ0CTL0)
- TMQ0 control register 1 (TQ0CTL1)
- TMQ0 I/O control register 0 (TQ0IOC0)
- TMQ0 I/O control register 1 (TQ0IOC1)
- TMQ0 I/O control register 2 (TQ0IOC2)
- TMQ0 option register 0 (TQ0OPT0)
- TMQ0 capture/compare register 0 (TQ0CCR0)
- TMQ0 capture/compare register 1 (TQ0CCR1)
- TMQ0 capture/compare register 2 (TQ0CCR2)
- TMQ0 capture/compare register 3 (TQ0CCR3)
- TMQ0 counter read buffer register (TQ0CNT)

**Remark** When using the functions of the TIQ00 to TIQ03 and TOQ00 to TOQ03 pins, refer to **Table 4-25 Using Port Pin as Alternate-Function Pin**.

**(1) TMQ0 control register 0 (TQ0CTL0)**

The TQ0CTL0 register is an 8-bit register that controls the operation of TMQ0.

This register can be read or written in 8-bit or 1-bit units.

Reset sets this register to 00H.

The same value can always be written to the TQ0CTL0 register by software.

After reset: 00H    R/W    Address:    FFFFF540H

<7>	6	5	4	3	2	1	0	
TQ0CTL0	TQ0CE	0	0	0	0	TQ0CKS2	TQ0CKS1	TQ0CKS0

TQ0CE	TMQ0 operation control
0	TMQ0 operation disabled (TMQ0 reset asynchronously <sup>Note</sup> ).
1	TMQ0 operation enabled. TMQ0 operation started.

TQ0CKS2	TQ0CKS1	TQ0CKS0	Internal count clock selection
0	0	0	$f_{XP}$
0	0	1	$f_{XP}/2$
0	1	0	$f_{XX}/4$
0	1	1	$f_{XP}/8$
1	0	0	$f_{XP}/16$
1	0	1	$f_{XP}/32$
1	1	0	$f_{XP}/64$
1	1	1	$f_{XP}/128$

**Note** The TQ0OPT0.TQ0OVF bit and 16-bit counter are reset at the same time. In addition, the timer output pins (TOQ00 to TOQ03 pins) are reset to the status set by the TQ0IOC0 register when the 16-bit counter is reset.

- Cautions**
1. Set the TQ0CKS2 to TQ0CKS0 bits when the TQ0CE bit = 0. When the value of the TQ0CE bit is changed from 0 to 1, the TQ0CKS2 to TQ0CKS0 bits can be set simultaneously.
  2. Be sure to clear bits 3 to 6 to "0".

**Remark**  $f_{XP}$ : Peripheral clock frequency (prescaler 1 input clock frequency).  
 In clock mode 1,  $f_{XP} = f_{XX}$   
 In clock mode 2,  $f_{XP} = f_{XMPLL}/2$  (14.64 to 16 MHz)  
 In clock mode 3,  $f_{XP} = f_{XMPLL}$  (29.28 to 32 MHz)  
 In clock mode 4,  $f_{XP} = f_{XMPLL}/2$  (20.88 to 24 MHz)  
 $f_{XX}$ : Main clock frequency  
 $f_{XMPLL}$ : PLL output clock frequency for peripheral clocks

**(2) TMQ0 control register 1 (TQ0CTL1)**

The TQ0CTL1 register is an 8-bit register that controls the operation of TMQ0.

This register can be read or written in 8-bit or 1-bit units.

Reset sets this register to 00H.

After reset: 00H R/W Address: FFFFF541H

	7	<6>	<5>	4	3	2	1	0
TQ0CTL1	0	TQ0EST	TQ0EEE	0	0	TQ0MD2	TQ0MD1	TQ0MD0

TQ0EST	Software trigger control
0	–
1	Generate a valid signal for external trigger input. <ul style="list-style-type: none"> <li>• In one-shot pulse output mode: A one-shot pulse is output with writing 1 to the TQ0EST bit as the trigger.</li> <li>• In external trigger pulse output mode: A PWM waveform is output with writing 1 to the TQ0EST bit as the trigger.</li> </ul>
The read value of TQ0EST bit is always 0.	

TQ0EEE	Count clock selection
0	Disable operation with external event count input (TIQ00 pin). (Perform counting with the count clock selected by the TQ0CTL0.TQ0CKS0 to TQ0CKS2 bits.)
1	Enable operation with external event count input (TIQ00 pin). (Perform counting at the valid edge of the external event count input signal.)
The TQ0EEE bit selects whether counting is performed with the internal count clock or the valid edge of the external event count input.	

TQ0MD2	TQ0MD1	TQ0MD0	Timer mode selection
0	0	0	Interval timer mode
0	0	1	External event count mode
0	1	0	External trigger pulse output mode
0	1	1	One-shot pulse output mode
1	0	0	PWM output mode
1	0	1	Free-running timer mode
1	1	0	Pulse width measurement mode
1	1	1	Setting prohibited

- Cautions**
1. The TQ0EST bit is valid only in the external trigger pulse output mode or one-shot pulse output mode. In any other mode, writing 1 to this bit is ignored.
  2. External event count input is selected in the external event count mode regardless of the value of the TQ0EEE bit.
  3. Set the TQ0EEE and TQ0MD2 to TQ0MD0 bits when the TQ0CTL0.TQ0CE bit = 0. (The same value can be written when the TQ0CE bit = 1.) The operation is not guaranteed when rewriting is performed with the TQ0CE bit = 1. If rewriting was mistakenly performed, clear the TQ0CE bit to 0 and then set the bits again.
  4. Be sure to clear bits 3, 4, and 7 to “0”.

**(3) TMQ0 I/O control register 0 (TQ0IOC0)**

The TQ0IOC0 register is an 8-bit register that controls the timer output (TOQ00 to TOQ03 pins). This register can be read or written in 8-bit or 1-bit units. Reset sets this register to 00H.

After reset: 00H    R/W    Address: FFFFF542H

	7	<6>	5	<4>	3	<2>	1	<0>
TQ0IOC0	TQ0OL3	TQ0OE3	TQ0OL2	TQ0OE2	TQ0OL1	TQ0OE1	TQ0OL0	TQ0OE0

TQ0OLm	TOQ0m pin output level setting (m = 0 to 3) <sup>Note</sup>
0	TOQ0m pin output starts at high level
1	TOQ0m pin output starts at low level

TQ0OEm	TOQ0m pin output setting (m = 0 to 3)
0	Timer output disabled <ul style="list-style-type: none"> <li>• When TQ0OLm bit = 0: Low level is output from the TOQ0m pin</li> <li>• When TQ0OLm bit = 1: High level is output from the TOQ0m pin</li> </ul>
1	Timer output enabled (A pulse is output from the TOQ0m pin).

**Note** The output level of the timer output pin (TOQ0m) specified by the TQ0OLm bit is shown below.

• When TQ0OLm bit = 0

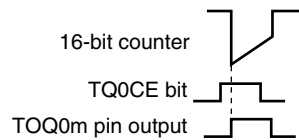

• When TQ0OLm bit = 1

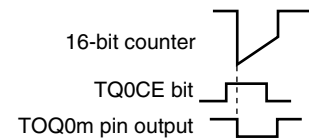

- Cautions**
1. The pin output changes if the setting of the TQ0IOC0 register is rewritten when the port is set to output TOQ0m. Therefore, note changes in the pin status by setting the port in the input mode and making the output status of the pins a high-impedance state.
  2. Rewrite the TQ0OLm and TQ0OEm bits when the TQ0CTL0.TQ0CE bit = 0. (The same value can be written when the TQ0CE bit = 1.) If rewriting was mistakenly performed, clear the TQ0CE bit to 0 and then set the bits again.
  3. Even if the TQ0OLm bit is manipulated when the TQ0CE and TQ0OEm bits are 0, the TOQ0m pin output level varies.

**Remark** m = 0 to 3

**(4) TMQ0 I/O control register 1 (TQ0IOC1)**

The TQ0IOC1 register is an 8-bit register that controls the valid edge of the capture trigger input signals (TIQ00 to TIQ03 pins).

This register can be read or written in 8-bit or 1-bit units.

Reset sets this register to 00H.

After reset: 00H    R/W    Address:    FFFFF543H

	7	6	5	4	3	2	1	0
TQ0IOC1	TQ0IS7	TQ0IS6	TQ0IS5	TQ0IS4	TQ0IS3	TQ0IS2	TQ0IS1	TQ0IS0

TQ0IS7	TQ0IS6	Capture trigger input signal (TIQ03 pin) valid edge setting
0	0	No edge detection (capture operation invalid)
0	1	Detection of rising edge
1	0	Detection of falling edge
1	1	Detection of both edges

TQ0IS5	TQ0IS4	Capture trigger input signal (TIQ02 pin) valid edge detection
0	0	No edge detection (capture operation invalid)
0	1	Detection of rising edge
1	0	Detection of falling edge
1	1	Detection of both edges

TQ0IS3	TQ0IS2	Capture trigger input signal (TIQ01 pin) valid edge setting
0	0	No edge detection (capture operation invalid)
0	1	Detection of rising edge
1	0	Detection of falling edge
1	1	Detection of both edges

TQ0IS1	TQ0IS0	Capture trigger input signal (TIQ00 pin) valid edge setting
0	0	No edge detection (capture operation invalid)
0	1	Detection of rising edge
1	0	Detection of falling edge
1	1	Detection of both edges

- Cautions**
1. Rewrite the TQ0IS7 to TQ0IS0 bits when the TQ0CTL0.TQ0CE bit = 0. (The same value can be written when the TQ0CE bit = 1.) If rewriting was mistakenly performed, clear the TQ0CE bit to 0 and then set the bits again.
  2. The TQ0IS7 to TQ0IS0 bits are valid only in the free-running timer mode (only when TQ0OPT0.TQ0CCSm bit = 1) and the pulse width measurement mode (m = 0 to 3). In all other modes, a capture operation is not possible.



**(5) TMQ0 I/O control register 2 (TQ0IOC2)**

The TQ0IOC2 register is an 8-bit register that controls the valid edge of the external event count input signal (TIQ00 pin) and external trigger input signal (TIQ00 pin).

This register can be read or written in 8-bit or 1-bit units.

Reset sets this register to 00H.

After reset: 00H		R/W	Address: FFFFF544H					
	7	6	5	4	3	2	1	0
TQ0IOC2	0	0	0	0	TQ0EES1	TQ0EES0	TQ0ETS1	TQ0ETS0

TQ0EES1	TQ0EES0	External event count input signal (TIQ00 pin) valid edge setting
0	0	No edge detection (external event count invalid)
0	1	Detection of rising edge
1	0	Detection of falling edge
1	1	Detection of both edges

TQ0ETS1	TQ0ETS0	External trigger input signal (TIQ00 pin) valid edge setting
0	0	No edge detection (external trigger invalid)
0	1	Detection of rising edge
1	0	Detection of falling edge
1	1	Detection of both edges

- Cautions**
1. Rewrite the TQ0EES1, TQ0EES0, TQ0ETS1, and TQ0ETS0 bits when the TQ0CTL0.TQ0CE bit = 0. (The same value can be written when the TQ0CE bit = 1.) If rewriting was mistakenly performed, clear the TQ0CE bit to 0 and then set the bits again.
  2. The TQ0EES1 and TQ0EES0 bits are valid only when the TQ0CTL1.TQ0EEE bit = 1 or when the external event count mode (TQ0CTL1.TQ0MD2 to TQ0CTL1.TQ0MD0 bits = 001) has been set.
  3. The TQ0ETS1 and TQ0ETS0 bits are valid only when the external trigger pulse output mode (TQ0CTL1.TQ0MD2 to TQ0CTL1.TQ0MD0 bits = 010) or the one-shot pulse output mode (TQ0CTL1.TQ0MD2 to TQ0CTL1.TQ0MD0 = 011) is set.

**(6) TMQ0 option register 0 (TQ0OPT0)**

The TQ0OPT0 register is an 8-bit register used to set the capture/compare operation and detect an overflow.

This register can be read or written in 8-bit or 1-bit units.

Reset sets this register to 00H.

After reset: 00H R/W Address: FFFFF545H

	7	6	5	4	3	2	1	<0>
TQ0OPT0	TQ0CCS3	TQ0CCS2	TQ0CCS1	TQ0CCS0	0	0	0	TQ0OVF

TQ0CCSm	TQ0CCRm register capture/compare selection
0	Compare register selected
1	Capture register selected (cleared by setting the TQ0CTL0.TQ0CE bit = 0)
The TQ0CCSm bit setting is valid only in the free-running timer mode.	

TQ0OVF	TMQ0 overflow detection flag
Set (1)	Overflow occurred
Reset (0)	TQ0OVF bit 0 written or TQ0CTL0.TQ0CE bit = 0
<ul style="list-style-type: none"> <li>• The TQ0OVF bit is set when the 16-bit counter count value overflows from FFFFH to 0000H in the free-running timer mode or the pulse width measurement mode.</li> <li>• An overflow interrupt request signal (INTTQ0OV) is generated at the same time that the TQ0OVF bit is set to 1. The INTTQ0OV signal is not generated in modes other than the free-running timer mode and the pulse width measurement mode.</li> <li>• The TQ0OVF bit is not cleared to 0 even when the TQ0OVF bit or the TQ0OPT0 register are read when the TQ0OVF bit = 1.</li> <li>• Before clearing the TQ0OVF bit to 0 after the INTTQ0OV signal has been generated, be sure to confirm (read) that the TQ0OVF bit is set to 1.</li> <li>• The TQ0OVF bit can be both read and written, but the TQ0OVF bit cannot be set to 1 by software. Writing 1 has no influence on the operation of TMQ0.</li> </ul>	

**Cautions**

1. Rewrite the TQ0CCS3 to TQ0CCS0 bits when the TQ0CTL0.TQ0CE bit = 0. (The same value can be written when the TQ0CE bit = 1.) If rewriting was mistakenly performed, clear the TQ0CE bit to 0 and then set the bits again.

2. Be sure to clear bits 1 to 3 to "0".

**Remark** m = 0 to 3

**(7) TMQ0 capture/compare register 0 (TQ0CCR0)**

The TQ0CCR0 register is a 16-bit register that can be used as a capture register or a compare register depending on the mode.

This register can be used as a capture register or a compare register only in the free-running timer mode, depending on the setting of the TQ0OPT0.TQ0CCS0 bit. In the pulse width measurement mode, the TQ0CCR0 register can be used only as a capture register. In any other mode, this register can be used only as a compare register.

The TQ0CCR0 register can be read or written during operation.

This register can be read or written in 16-bit units.

Reset sets this register to 0000H.

**Caution** Accessing the TQ0CCR0 register is prohibited in the following statuses. For details, refer to 3.4.9 (2) Accessing specific on-chip peripheral I/O registers.

- When the CPU operates with the subclock and the main clock oscillation is stopped
- When the CPU operates with the internal oscillation clock

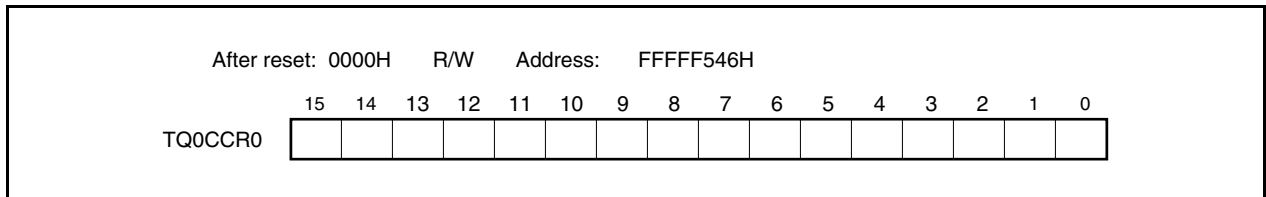

**(a) Function as compare register**

The TQ0CCR0 register can be rewritten even when the TQ0CTL0.TQ0CE bit = 1.

The set value of the TQ0CCR0 register is transferred to the CCR0 buffer register. When the value of the 16-bit counter matches the value of the CCR0 buffer register, a compare match interrupt request signal (INTTQ0CC0) is generated. If TOQ00 pin output is enabled at this time, the output of the TOQ00 pin is inverted.

When the TQ0CCR0 register is used as a cycle register in the interval timer mode, external event count mode, external trigger pulse output mode, one-shot pulse output mode, or PWM output mode, the value of the 16-bit counter is cleared (0000H) if its count value matches the value of the CCR0 buffer register.

The compare register is not cleared when the TQ0CTL0.TQ0CE bit = 0.

**(b) Function as capture register**

When the TQ0CCR0 register is used as a capture register in the free-running timer mode, the count value of the 16-bit counter is stored in the TQ0CCR0 register if the valid edge of the capture trigger input pin (TIQ00 pin) is detected. In the pulse-width measurement mode, the count value of the 16-bit counter is stored in the TQ0CCR0 register and the 16-bit counter is cleared (0000H) if the valid edge of the capture trigger input pin (TIQ00 pin) is detected.

Even if the capture operation and reading the TQ0CCR0 register conflict, the correct value of the TQ0CCR0 register can be read.

The capture register is cleared when the TQ0CTL0.TQ0CE bit = 0.

The following table shows the functions of the capture/compare register in each mode, and how to write data to the compare register.

**Table 8-2. Function of Capture/Compare Register in Each Mode and How to Write Compare Register**

Operation Mode	Capture/Compare Register	How to Write Compare Register
Interval timer	Compare register	Anytime write
External event counter	Compare register	Anytime write
External trigger pulse output	Compare register	Batch write <sup>Note</sup>
One-shot pulse output	Compare register	Anytime write
PWM output	Compare register	Batch write <sup>Note</sup>
Free-running timer	Capture/compare register	Anytime write
Pulse width measurement	Capture register	None

**Note** Triggered by writing to the TQ0CCR1 register

**Remark** For anytime write and batch write, **8.6 (2) Anytime write and batch write.**

**(8) TMQ0 capture/compare register 1 (TQ0CCR1)**

The TQ0CCR1 register is a 16-bit register that can be used as a capture register or a compare register depending on the mode.

This register can be used as a capture register or a compare register only in the free-running timer mode, depending on the setting of the TQ0OPT0.TQ0CCS1 bit. In the pulse width measurement mode, the TQ0CCR1 register can be used only as a capture register. In any other mode, this register can be used only as a compare register.

The TQ0CCR1 register can be read or written during operation.

This register can be read or written in 16-bit units.

Reset sets this register to 0000H.

**Caution** Accessing the TQ0CCR1 register is prohibited in the following statuses. For details, refer to 3.4.9 (2) Accessing specific on-chip peripheral I/O registers.

- When the CPU operates with the subclock and the main clock oscillation is stopped
- When the CPU operates with the internal oscillation clock

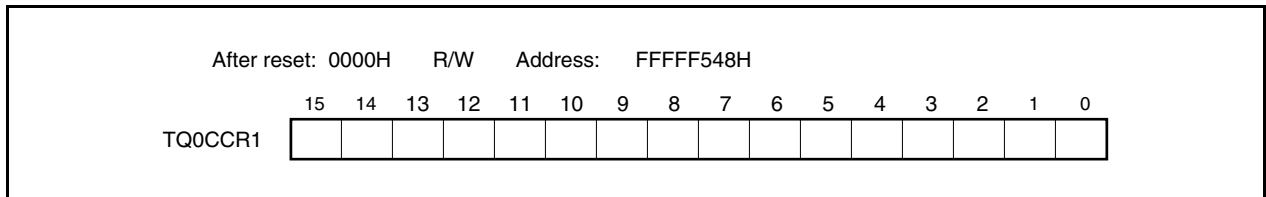

**(a) Function as compare register**

The TQ0CCR1 register can be rewritten even when the TQ0CTL0.TQ0CE bit = 1.

The set value of the TQ0CCR1 register is transferred to the CCR1 buffer register. When the value of the 16-bit counter matches the value of the CCR1 buffer register, a compare match interrupt request signal (INTTQ0CC1) is generated. If TOQ01 pin output is enabled at this time, the output of the TOQ01 pin is inverted.

The compare register is not cleared when the TQ0CTL0.TQ0CE bit = 0.

**(b) Function as capture register**

When the TQ0CCR1 register is used as a capture register in the free-running timer mode, the count value of the 16-bit counter is stored in the TQ0CCR1 register if the valid edge of the capture trigger input pin (TIQ01 pin) is detected. In the pulse-width measurement mode, the count value of the 16-bit counter is stored in the TQ0CCR1 register and the 16-bit counter is cleared (0000H) if the valid edge of the capture trigger input pin (TIQ01 pin) is detected.

Even if the capture operation and reading the TQ0CCR1 register conflict, the correct value of the TQ0CCR1 register can be read.

The capture register is cleared when the TQ0CTL0.TQ0CE bit = 0.

The following table shows the functions of the capture/compare register in each mode, and how to write data to the compare register.

**Table 8-3. Function of Capture/Compare Register in Each Mode and How to Write Compare Register**

Operation Mode	Capture/Compare Register	How to Write Compare Register
Interval timer	Compare register	Anytime write
External event counter	Compare register	Anytime write
External trigger pulse output	Compare register	Batch write <sup>Note</sup>
One-shot pulse output	Compare register	Anytime write
PWM output	Compare register	Batch write <sup>Note</sup>
Free-running timer	Capture/compare register	Anytime write
Pulse width measurement	Capture register	None

**Note** Triggered by writing to the TQ0CCR1 register

**Remark** For anytime write and batch write, see **8.6 (2) Anytime write and batch write**.

**(9) TMQ0 capture/compare register 2 (TQ0CCR2)**

The TQ0CCR2 register is a 16-bit register that can be used as a capture register or a compare register depending on the mode.

This register can be used as a capture register or a compare register only in the free-running timer mode, depending on the setting of the TQ0OPT0.TQ0CCS2 bit. In the pulse width measurement mode, the TQ0CCR2 register can be used only as a capture register. In any other mode, this register can be used only as a compare register.

The TQ0CCR2 register can be read or written during operation.

This register can be read or written in 16-bit units.

Reset sets this register to 0000H.

**Caution** Accessing the TQ0CCR2 register is prohibited in the following statuses. For details, refer to 3.4.9 (2) Accessing specific on-chip peripheral I/O registers.

- When the CPU operates with the subclock and the main clock oscillation is stopped
- When the CPU operates with the internal oscillation clock

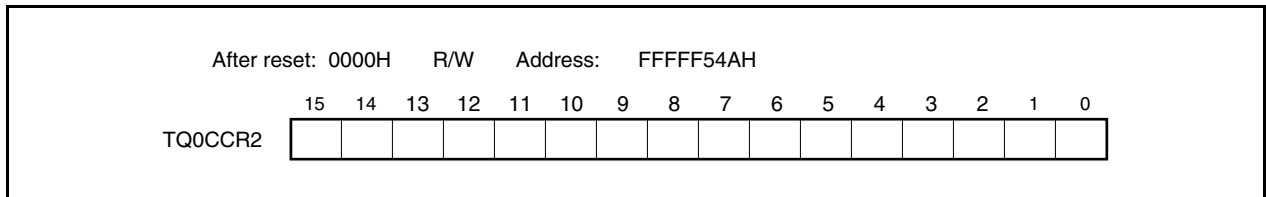

**(a) Function as compare register**

The TQ0CCR2 register can be rewritten even when the TQ0CTL0.TQ0CE bit = 1.

The set value of the TQ0CCR2 register is transferred to the CCR2 buffer register. When the value of the 16-bit counter matches the value of the CCR2 buffer register, a compare match interrupt request signal (INTTQ0CC2) is generated. If TOQ02 pin output is enabled at this time, the output of the TOQ02 pin is inverted.

The compare register is not cleared when the TQ0CTL0.TQ0CE bit = 0.

**(b) Function as capture register**

When the TQ0CCR2 register is used as a capture register in the free-running timer mode, the count value of the 16-bit counter is stored in the TQ0CCR2 register if the valid edge of the capture trigger input pin (TIQ02 pin) is detected. In the pulse-width measurement mode, the count value of the 16-bit counter is stored in the TQ0CCR2 register and the 16-bit counter is cleared (0000H) if the valid edge of the capture trigger input pin (TIQ02 pin) is detected.

Even if the capture operation and reading the TQ0CCR2 register conflict, the correct value of the TQ0CCR2 register can be read.

The capture register is cleared when the TQ0CTL0.TQ0CE bit = 0.

The following table shows the functions of the capture/compare register in each mode, and how to write data to the compare register.

**Table 8-4. Function of Capture/Compare Register in Each Mode and How to Write Compare Register**

Operation Mode	Capture/Compare Register	How to Write Compare Register
Interval timer	Compare register	Anytime write
External event counter	Compare register	Anytime write
External trigger pulse output	Compare register	Batch write <sup>Note</sup>
One-shot pulse output	Compare register	Anytime write
PWM output	Compare register	Batch write <sup>Note</sup>
Free-running timer	Capture/compare register	Anytime write
Pulse width measurement	Capture register	None

**Note** Triggered by writing to the TQ0CCR1 register

**Remark** For anytime write and batch write, see **8.6 (2) Anytime write and batch write**.



**(10) TMQ0 capture/compare register 3 (TQ0CCR3)**

The TQ0CCR3 register is a 16-bit register that can be used as a capture register or a compare register depending on the mode.

This register can be used as a capture register or a compare register only in the free-running timer mode, depending on the setting of the TQ0OPT0.TQ0CCS3 bit. In the pulse width measurement mode, the TQ0CCR3 register can be used only as a capture register. In any other mode, this register can be used only as a compare register.

The TQ0CCR3 register can be read or written during operation.

This register can be read or written in 16-bit units.

Reset sets this register to 0000H.

**Caution** Accessing the TQ0CCR3 register is prohibited in the following statuses. For details, refer to 3.4.9 (2) Accessing specific on-chip peripheral I/O registers.

- When the CPU operates with the subclock and the main clock oscillation is stopped
- When the CPU operates with the internal oscillation clock

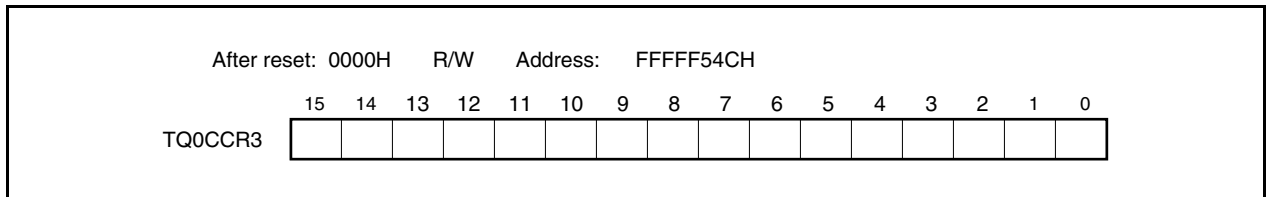

**(a) Function as compare register**

The TQ0CCR3 register can be rewritten even when the TQ0CTL0.TQ0CE bit = 1.

The set value of the TQ0CCR3 register is transferred to the CCR3 buffer register. When the value of the 16-bit counter matches the value of the CCR3 buffer register, a compare match interrupt request signal (INTTQ0CC3) is generated. If TOQ03 pin output is enabled at this time, the output of the TOQ03 pin is inverted.

The compare register is not cleared when the TQ0CTL0.TQ0CE bit = 0.

**(b) Function as capture register**

When the TQ0CCR3 register is used as a capture register in the free-running timer mode, the count value of the 16-bit counter is stored in the TQ0CCR3 register if the valid edge of the capture trigger input pin (TIQ03 pin) is detected. In the pulse-width measurement mode, the count value of the 16-bit counter is stored in the TQ0CCR3 register and the 16-bit counter is cleared (0000H) if the valid edge of the capture trigger input pin (TIQ03 pin) is detected.

Even if the capture operation and reading the TQ0CCR3 register conflict, the correct value of the TQ0CCR3 register can be read.

The capture register is cleared when the TQ0CTL0.TQ0CE bit = 0.

The following table shows the functions of the capture/compare register in each mode, and how to write data to the compare register.

**Table 8-5. Function of Capture/Compare Register in Each Mode and How to Write Compare Register**

Operation Mode	Capture/Compare Register	How to Write Compare Register
Interval timer	Compare register	Anytime write
External event counter	Compare register	Anytime write
External trigger pulse output	Compare register	Batch write <sup>Note</sup>
One-shot pulse output	Compare register	Anytime write
PWM output	Compare register	Batch write <sup>Note</sup>
Free-running timer	Capture/compare register	Anytime write
Pulse width measurement	Capture register	None

**Note** Triggered by writing to the TQ0CCR1 register

**Remark** For anytime write and batch write, see **8.6 (2) Anytime write and batch write**.

**(11) TMQ0 counter read buffer register (TQ0CNT)**

The TQ0CNT register is a read buffer register that can read the count value of the 16-bit counter.

If this register is read when the TQ0CTL0.TQ0CE bit = 1, the count value of the 16-bit timer can be read.

This register is read-only, in 16-bit units.

The value of the TQ0CNT register is cleared to 0000H when the TQ0CE bit = 0. If the TQ0CNT register is read at this time, the value of the 16-bit counter (FFFFH) is not read, but 0000H is read.

The value of the TQ0CNT register is cleared to 0000H after reset, as the TQ0CE bit is cleared to 0.

**Caution** Accessing the TQ0CNT register is prohibited in the following statuses. For details, refer to 3.4.9 (2) Accessing specific on-chip peripheral I/O registers.

- When the CPU operates with the subclock and the main clock oscillation is stopped
- When the CPU operates with the internal oscillation clock

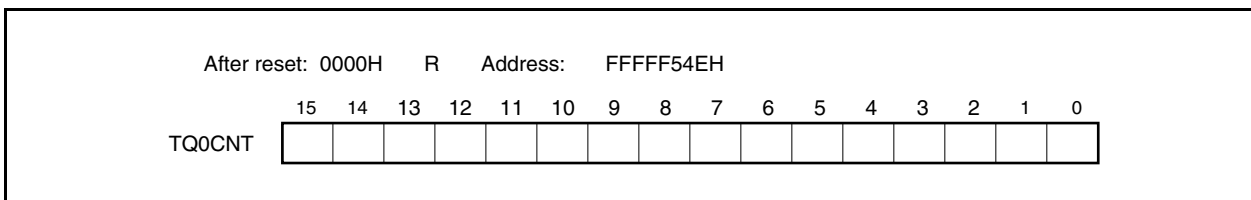

**8.5 Timer Output Operations**

The following table shows the operations and output levels of the TOQ00 to TOQ03 pins.

**Table 8-6. Timer Output Control in Each Mode**

Operation Mode	TOQ00 Pin	TOQ01 Pin	TOQ02 Pin	TOQ03 Pin
Interval timer mode	Square wave output			
External event count mode	None			
External trigger pulse output mode	Square wave output	External trigger pulse output		
One-shot pulse output mode		One-shot pulse output		
PWM output mode		PWM output		
Free-running timer mode	Square wave output (only when compare function is used)			
Pulse width measurement mode	None			

**Table 8-7. Truth Table of TOQ00 to TOQ03 Pins Under Control of Timer Output Control Bits**

TQ0IOC0.TQ0OLm Bit	TQ0IOC0.TQ0OEm Bit	TQ0CTL0.TQ0CE Bit	Level of TOQ0m Pin
0	0	×	Low-level output
	1	0	Low-level output
		1	Low level immediately before counting, high level after counting is started
1	0	×	High-level output
	1	0	High-level output
		1	High level immediately before counting, low level after counting is started

**Remark** m = 0 to 3

## 8.6 Operation

TMQ0 can perform the following operations.

Operation	TQ0CTL1.TQ0EST Bit (Software Trigger Bit)	TIQ00 Pin (External Trigger Input)	Capture/Compare Register Setting	Compare Register Write
Interval timer mode	Invalid	Invalid	Compare only	Anytime write
External event count mode <sup>Note 1</sup>	Invalid	Invalid	Compare only	Anytime write
External trigger pulse output mode <sup>Note 2</sup>	Valid	Valid	Compare only	Batch write
One-shot pulse output mode <sup>Note 2</sup>	Valid	Valid	Compare only	Anytime write
PWM output mode	Invalid	Invalid	Compare only	Batch write
Free-running timer mode	Invalid	Invalid	Switching enabled	Anytime write
Pulse width measurement mode <sup>Note 2</sup>	Invalid	Invalid	Capture only	Not applicable

**Notes 1.** To use the external event count mode, specify that the valid edge of the TIQ00 pin capture trigger input is not detected (by clearing the TQ0IOC1.TQ0IS1 and TQ0IOC1.TQ0IS0 bits to “00”).

- 2.** When using the external trigger pulse output mode, one-shot pulse output mode, and pulse width measurement mode, select the internal clock as the count clock (by clearing the TQ0CTL1.TQ0EEE bit to 0).

**(1) Counter basic operation**

This section explains the basic operation of the 16-bit counter. For details, refer to the description of the operation in each mode.

**(a) Counter start operation**

- External event count mode

When the TQ0CE bit value is changed from 0 to 1, the value of 0000H is set to the 16-bit counter.

After that, it counts up from 0001H, 0002H, 0003H, and so on each time the valid edge of the external event count input (TIQ00) is detected.

- Mode other than above

The 16-bit counter of TMQ0 starts counting from the default value FFFFH.

It counts up from FFFFH to 0000H, 0001H, 0002H, 0003H, and so on.

**(b) Clear operation**

The 16-bit counter is cleared to 0000H when its value matches the value of the compare register and when its value is captured. The counting operation from FFFFH to 0000H that takes place immediately after the counter has started counting or when the counter overflows is not a clearing operation. Therefore, the INTTQ0CCm interrupt signal is not generated (m = 0 to 3).

**(c) Overflow operation**

The 16-bit counter overflows when the counter counts up from FFFFH to 0000H in the free-running timer mode or pulse width measurement mode. If the counter overflows, the TQ0OPT0.TQ0OVF bit is set to 1 and an interrupt request signal (INTTQ0OV) is generated. Note that the INTTQ0OV signal is not generated under the following conditions.

- Immediately after a count operation has been started
- If the counter value matches the compare value FFFFH and is cleared
- When FFFFH is captured in the pulse width measurement mode and the counter counts up from FFFFH to 0000H

**Caution** After the overflow interrupt request signal (INTTQ0OV) has been generated, be sure to check that the overflow flag (TQ0OVF bit) is set to 1.

**(d) Counter read operation during counting operation**

The value of the 16-bit counter of TMQ0 can be read by using the TQ0CNT register during the count operation. When the TQ0CTL0.TQ0CE bit = 1, the value of the 16-bit counter can be read by reading the TQ0CNT register. When the TQ0CE bit = 0, the 16-bit counter is FFFFH and the TQ0CNT register is 0000H.

**(e) Interrupt operation**

TMQ0 generates the following five interrupt request signals.

- **INTTQ0CC0 interrupt:** This signal functions as a match interrupt request signal of the CCR0 buffer register and as a capture interrupt request signal to the TQ0CCR0 register.
- **INTTQ0CC1 interrupt:** This signal functions as a match interrupt request signal of the CCR1 buffer register and as a capture interrupt request signal to the TQ0CCR1 register.
- **INTTQ0CC2 interrupt:** This signal functions as a match interrupt request signal of the CCR2 buffer register and as a capture interrupt request signal to the TQ0CCR2 register.
- **INTTQ0CC3 interrupt:** This signal functions as a match interrupt request signal of the CCR3 buffer register and as a capture interrupt request signal to the TQ0CCR3 register.
- **INTTQ0OV interrupt:** This signal functions as an overflow interrupt request signal.

**(2) Anytime write and batch write**

The TQ0CCR0 to TQ0CCR3 registers can be rewritten in the TMQ0 during timer operation (TQ0CTL0.TQ0CE bit = 1), but the write method (anytime write, batch write) of the CCR0 to CCR3 buffer registers differs depending on the mode.

**(a) Anytime write**

In this mode, data is transferred at any time from the TQ0CCR0 to TQ0CCR3 registers to the CCR0 to CCR3 buffer registers during the timer operation.

**Figure 8-2. Flowchart of Basic Operation for Anytime Write**

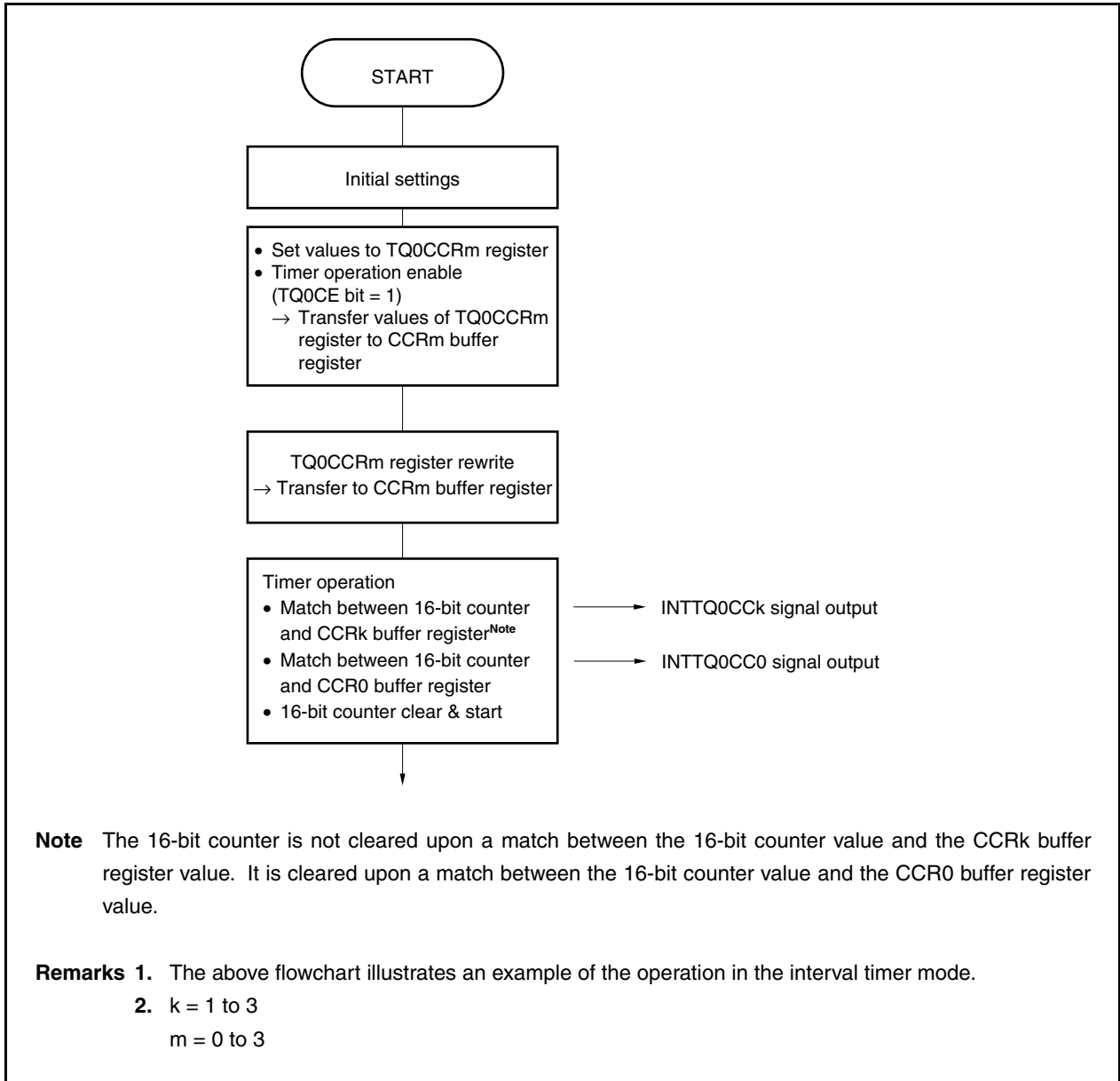
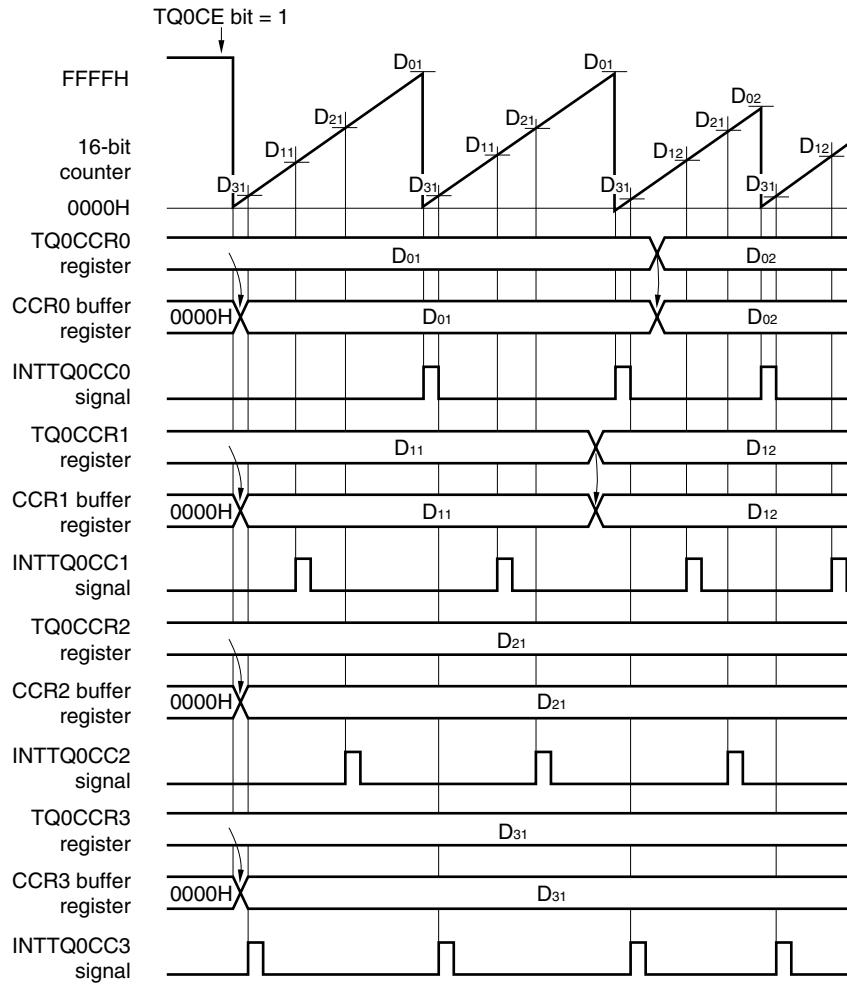

Figure 8-3. Timing of Anytime Write



- Remarks 1.** D<sub>01</sub>, D<sub>02</sub>: Setting values of TQ0CCR0 register  
 D<sub>11</sub>, D<sub>12</sub>: Setting values of TQ0CCR1 register  
 D<sub>21</sub>: Setting value of TQ0CCR2 register  
 D<sub>31</sub>: Setting value of TQ0CCR3 register

- 2.** The above timing chart illustrates an example of the operation in the interval timer mode.



**(b) Batch write**

In this mode, data is transferred all at once from the TQ0CCR0 to TQ0CCR3 registers to the CCR0 to CCR3 buffer registers during timer operation. This data is transferred upon a match between the value of the CCR0 buffer register and the value of the 16-bit counter. Transfer is enabled by writing to the TQ0CCR1 register.

Whether to enable or disable the next transfer timing is controlled by writing or not writing to the TQ0CCR1 register.

In order for the setting value when the TQ0CCR0 to TQ0CCR3 registers are rewritten to become the 16-bit counter comparison value (in other words, in order for this value to be transferred to the CCR0 to CCR3 buffer registers), it is necessary to rewrite TQ0CCR0 and finally write to the TQ0CCR1 register before the 16-bit counter value and the CCR0 buffer register value match. The values of the TQ0CCR0 to TQ0CCR3 registers are transferred to the CCR0 to CCR3 buffer registers upon a match between the count value of the 16-bit counter and the value of the CCR0 buffer register. Thus, even when wishing only to rewrite the value of the TQ0CCR0, TQ0CCR2, or TQ0CCR3 register, also write the same value (same as the value of the TQ0CCR1 register already set) to the TQ0CCR1 register.

Figure 8-4. Flowchart of Basic Operation for Batch Write

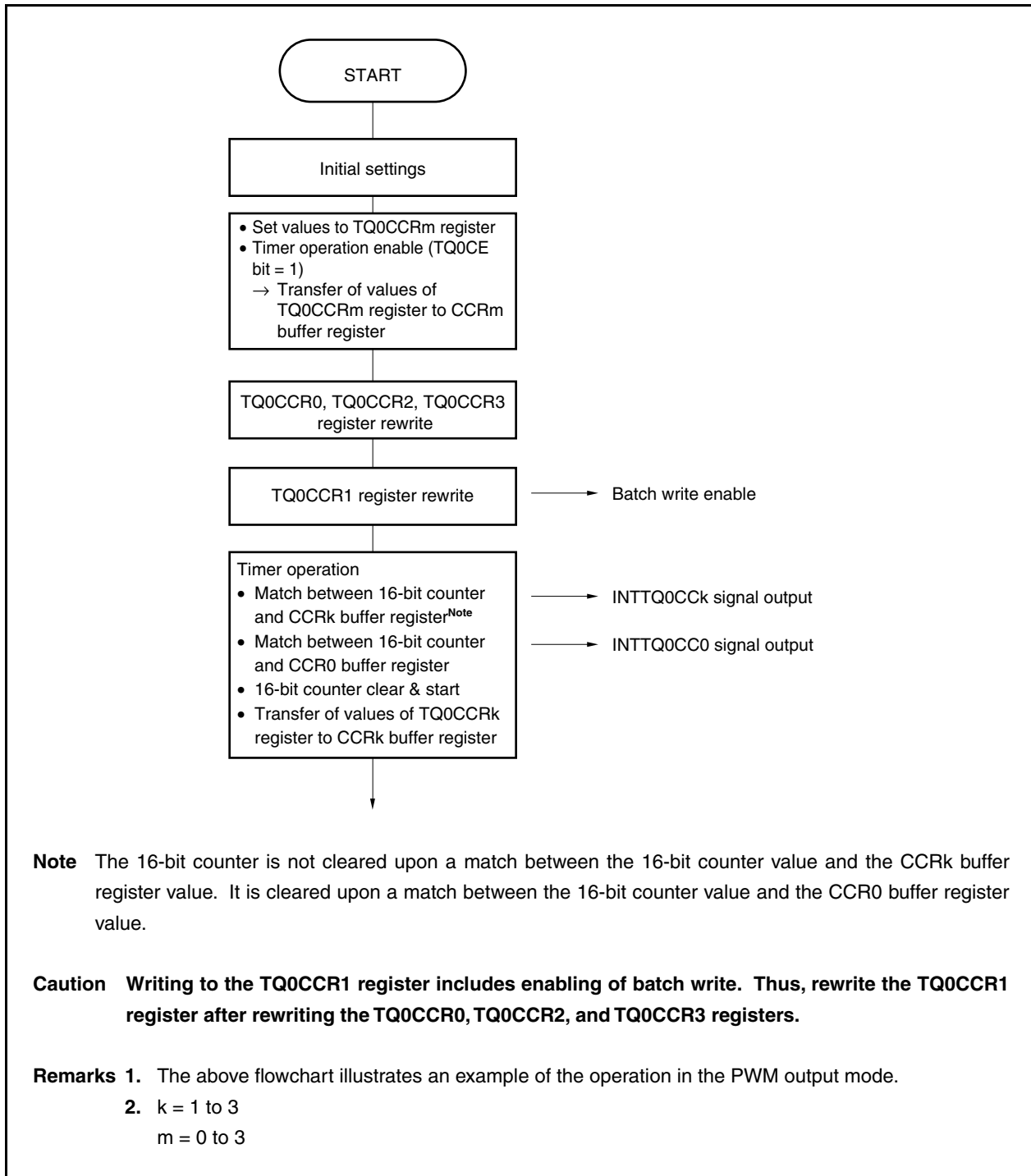
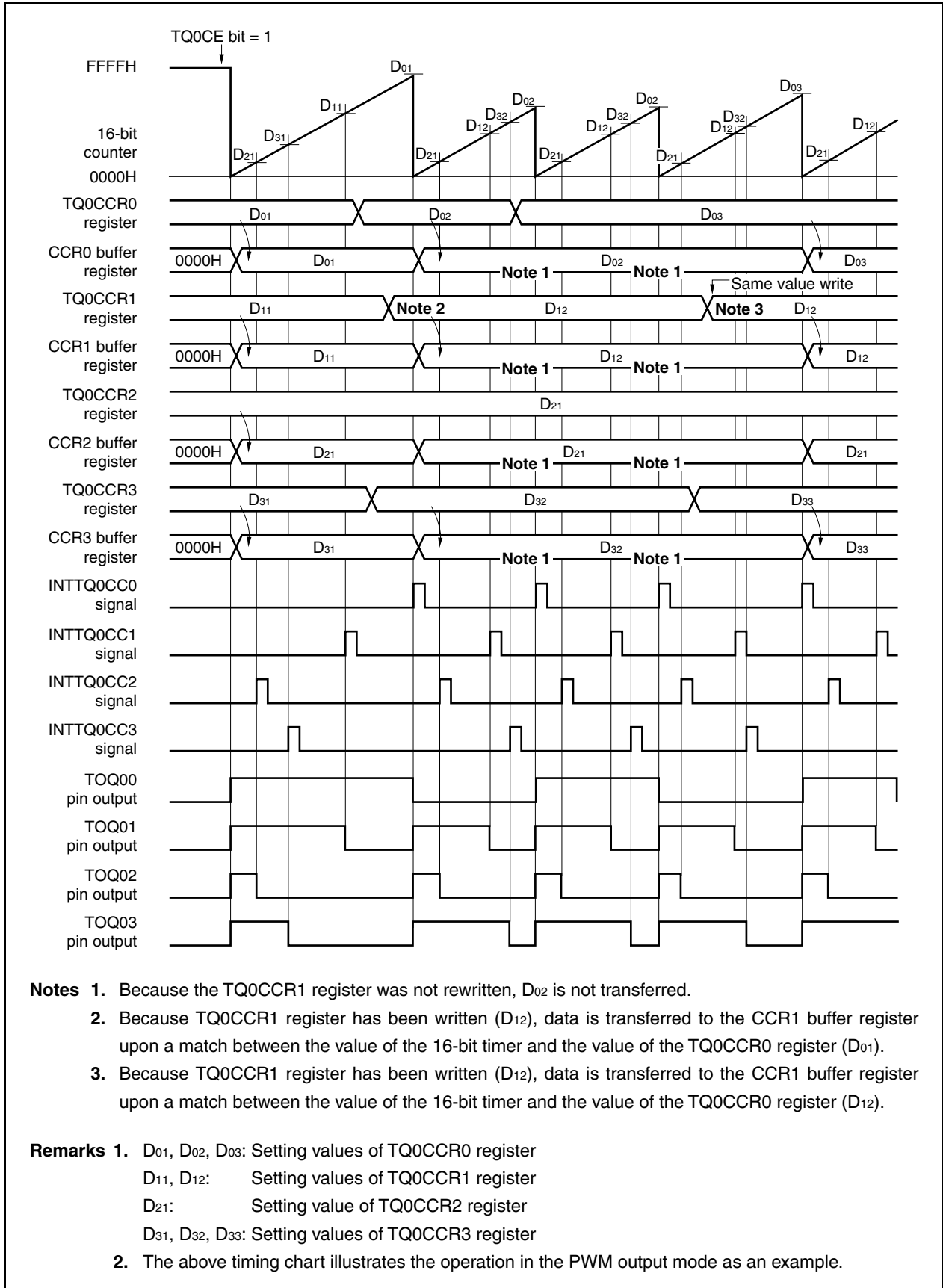

Figure 8-5. Timing of Batch Write



**8.6.1 Interval timer mode (TQ0MD2 to TQ0MD0 bits = 000)**

In the interval timer mode, an interrupt request signal (INTTQ0CC0) is generated at the interval set by the TQ0CCR0 register if the TQ0CTL0.TQ0CE bit is set to 1. A square wave with a duty factor of 50% whose half cycle is equal to the interval can be output from the TOQ00 pin.

The TQ0CCR1 to TQ0CCR3 registers are not used in the interval timer mode. However, the set value of the TQ0CCR1 to TQ0CCR3 registers is transferred to the CCR1 to CCR3 buffer registers and, when the count value of the 16-bit counter matches the value of the CCR1 to CCR3 buffer registers, compare match interrupt request signals (INTTQ0CC1 to INTTQ0CC3) are generated. In addition, a square wave with a duty factor of 50%, which is inverted when the INTTQ0CC1 to INTTQ0CC3 signals are generated, can be output from the TOQ01 to TOQ03 pins.

The value of the TQ0CCR1 to TQ0CCR3 registers can be rewritten even while the timer is operating.

**Figure 8-6. Configuration of Interval Timer**

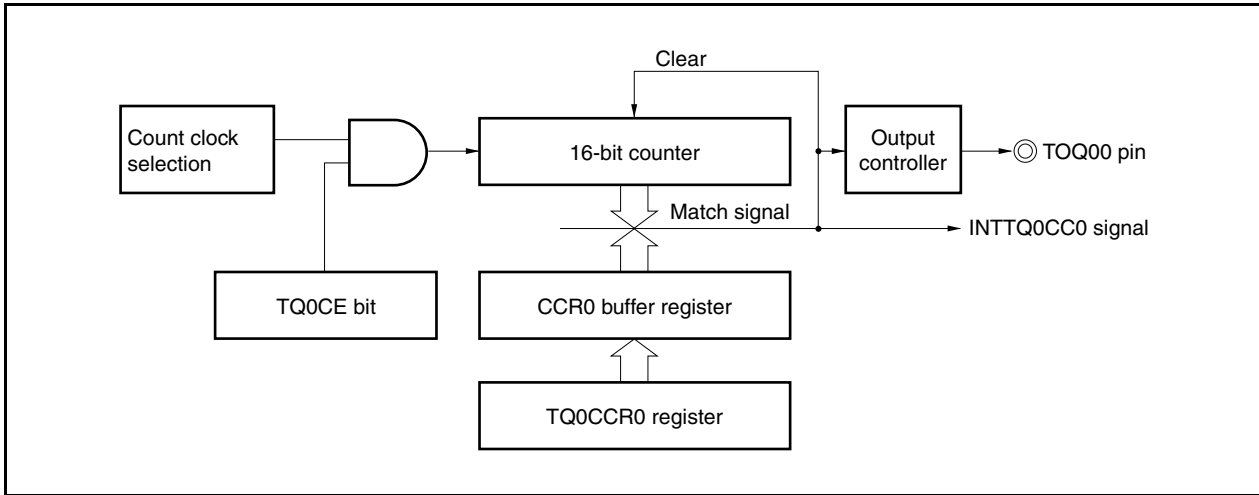

**Figure 8-7. Basic Timing of Operation in Interval Timer Mode**

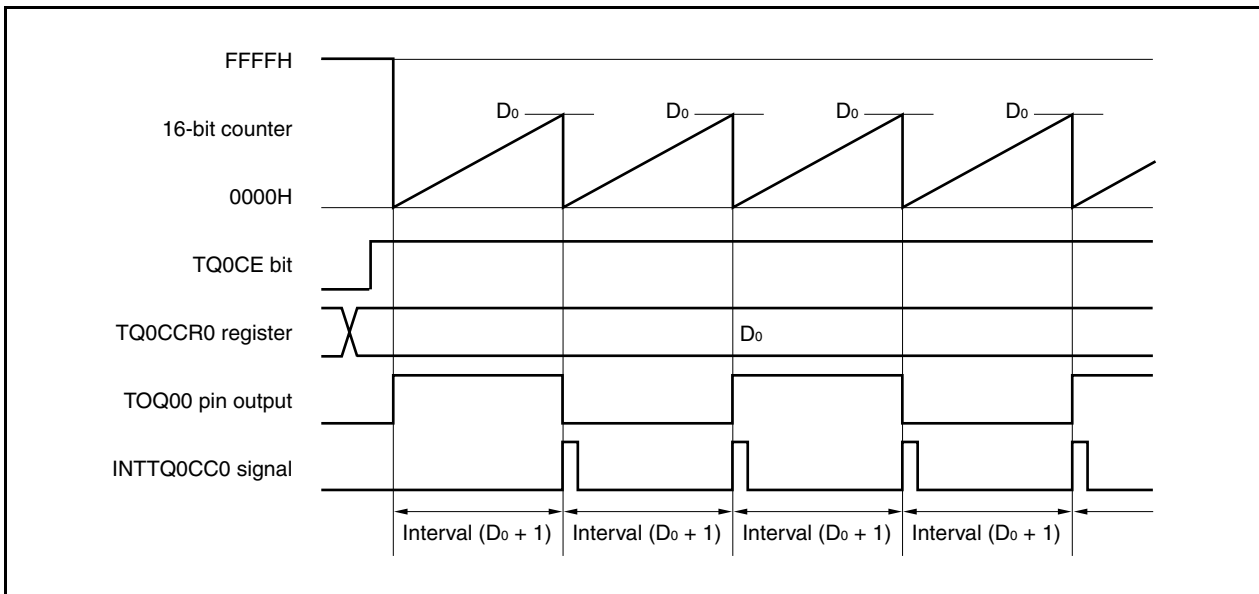

When the TQ0CE bit is set to 1, the value of the 16-bit counter is cleared from FFFFH to 0000H in synchronization with the count clock, and the counter starts counting. At this time, the output of the TOQ00 pin is inverted. Additionally, the set value of the TQ0CCR0 register is transferred to the CCR0 buffer register.

When the count value of the 16-bit counter matches the value of the CCR0 buffer register, the 16-bit counter is cleared to 0000H, the output of the TOQ00 pin is inverted, and a compare match interrupt request signal (INTTQ0CC0) is generated.

The interval can be calculated by the following expression.

$$\text{Interval} = (\text{Set value of TQ0CCR0 register} + 1) \times \text{Count clock cycle}$$

Figure 8-8. Register Setting for Interval Timer Mode Operation (1/3)

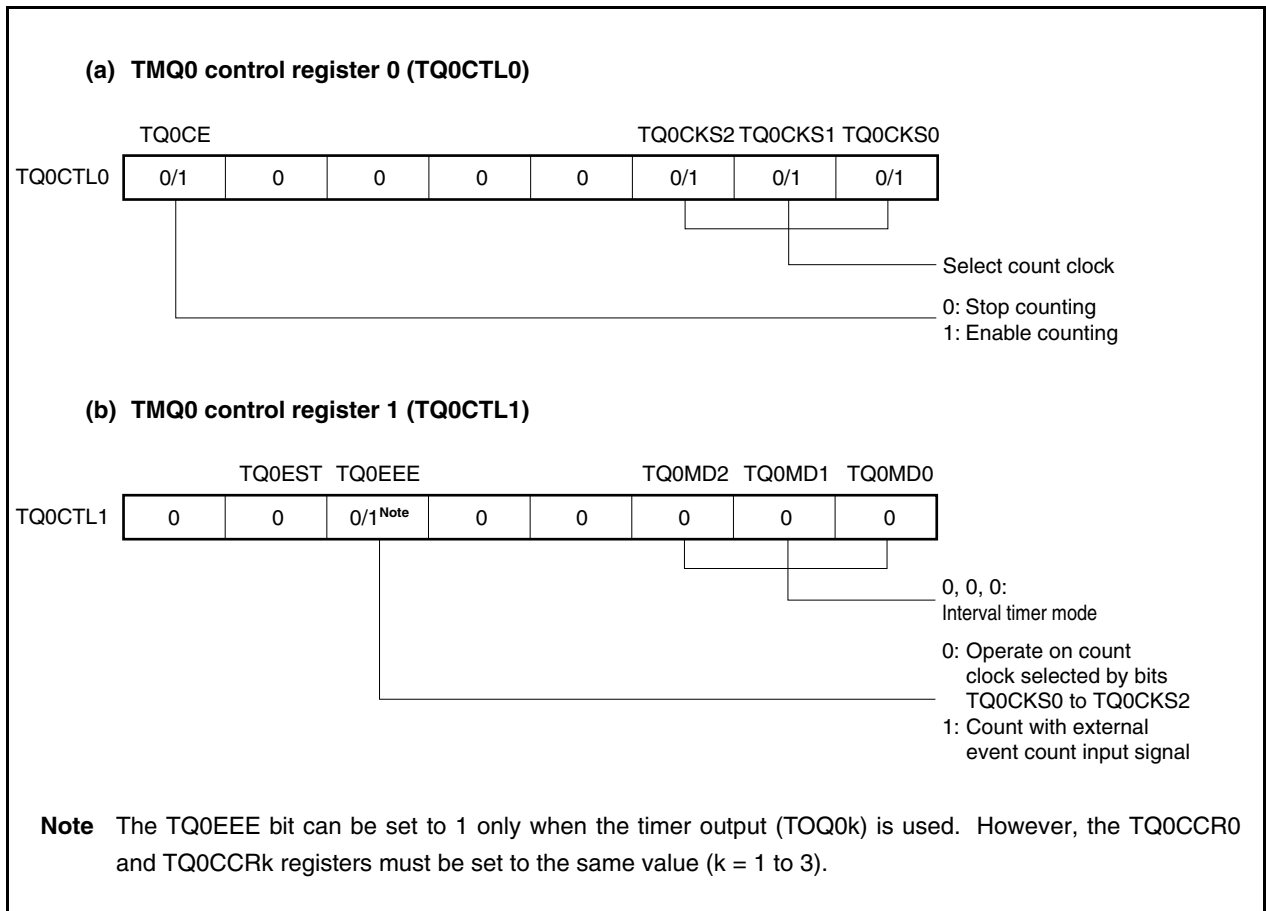
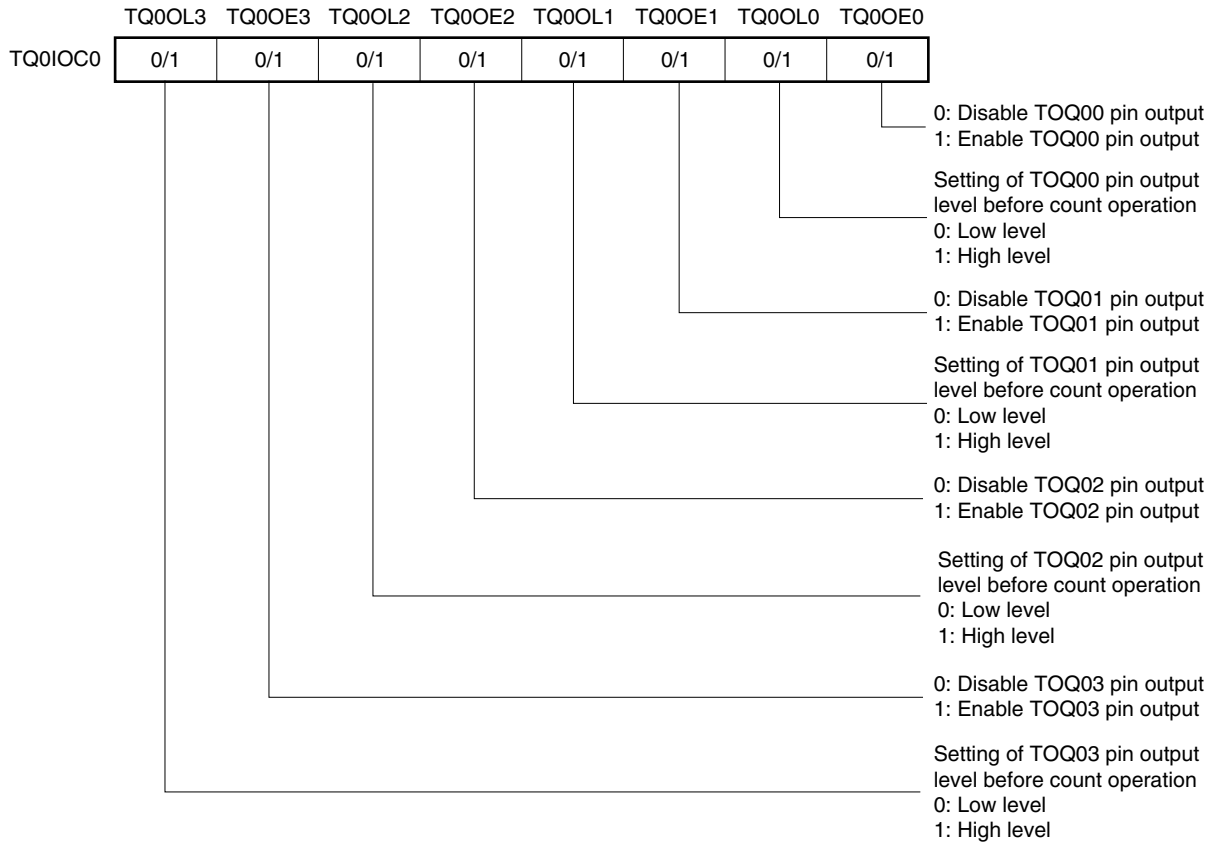
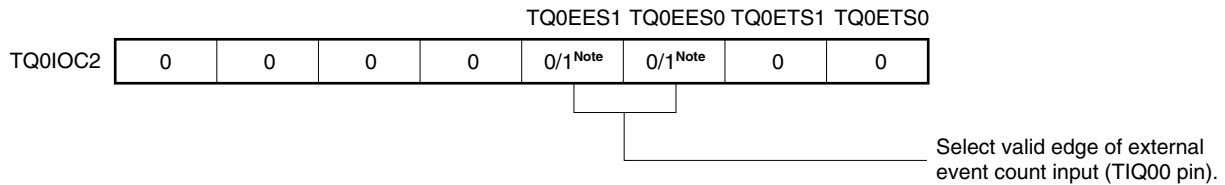

Figure 8-8. Register Setting for Interval Timer Mode Operation (2/3)

(c) TMQ0 I/O control register 0 (TQ0IOC0)



(d) TMQ0 I/O control register 2 (TQ0IOC2)



**Note** The TQ0EES1 and TQ0EES0 bits can be set only when timer outputs (TOQ01 to TOQ03) are used. However, set the TQ0CCR0 to TQ0CCR3 registers to the same value.

(e) TMQ0 counter read buffer register (TQ0CNT)

By reading the TQ0CNT register, the count value of the 16-bit counter can be read.

(f) TMQ0 capture/compare register 0 (TQ0CCR0)

If the TQ0CCR0 register is set to D<sub>0</sub>, the interval is as follows.

$$\text{Interval} = (D_0 + 1) \times \text{Count clock cycle}$$

Figure 8-8. Register Setting for Interval Timer Mode Operation (3/3)

**(g) TMQ0 capture/compare registers 1 to 3 (TQ0CCR1 to TQ0CCR3)**

The TQ0CCR1 to TQ0CCR3 registers are not used in the interval timer mode. However, the set value of the TQ0CCR1 to TQ0CCR3 registers are transferred to the CCR1 to CCR3 buffer registers. The TOQ01 to TOQ03 pin outputs are inverted and compare match interrupt request signals (INTTQ0CC1 to INTTQ0CC3) are generated when the count value of the 16-bit counter matches the value of the CCR1 to CCR3 buffer registers.

When the TQ0CCR1 to TQ0CCR3 registers are not used, it is recommended to set their values to FFFFH. Also mask the registers by the interrupt mask flags (TQ0CCIC1.TQ0CCMK1 to TQ0CCIC3.TQ0CCMK3).

**Remark** TMQ0 I/O control register 1 (TQ0IOC1) and TMQ0 option register 0 (TQ0OPT0) are not used in the interval timer mode.

(1) Interval timer mode operation flow

Figure 8-9. Software Processing Flow in Interval Timer Mode

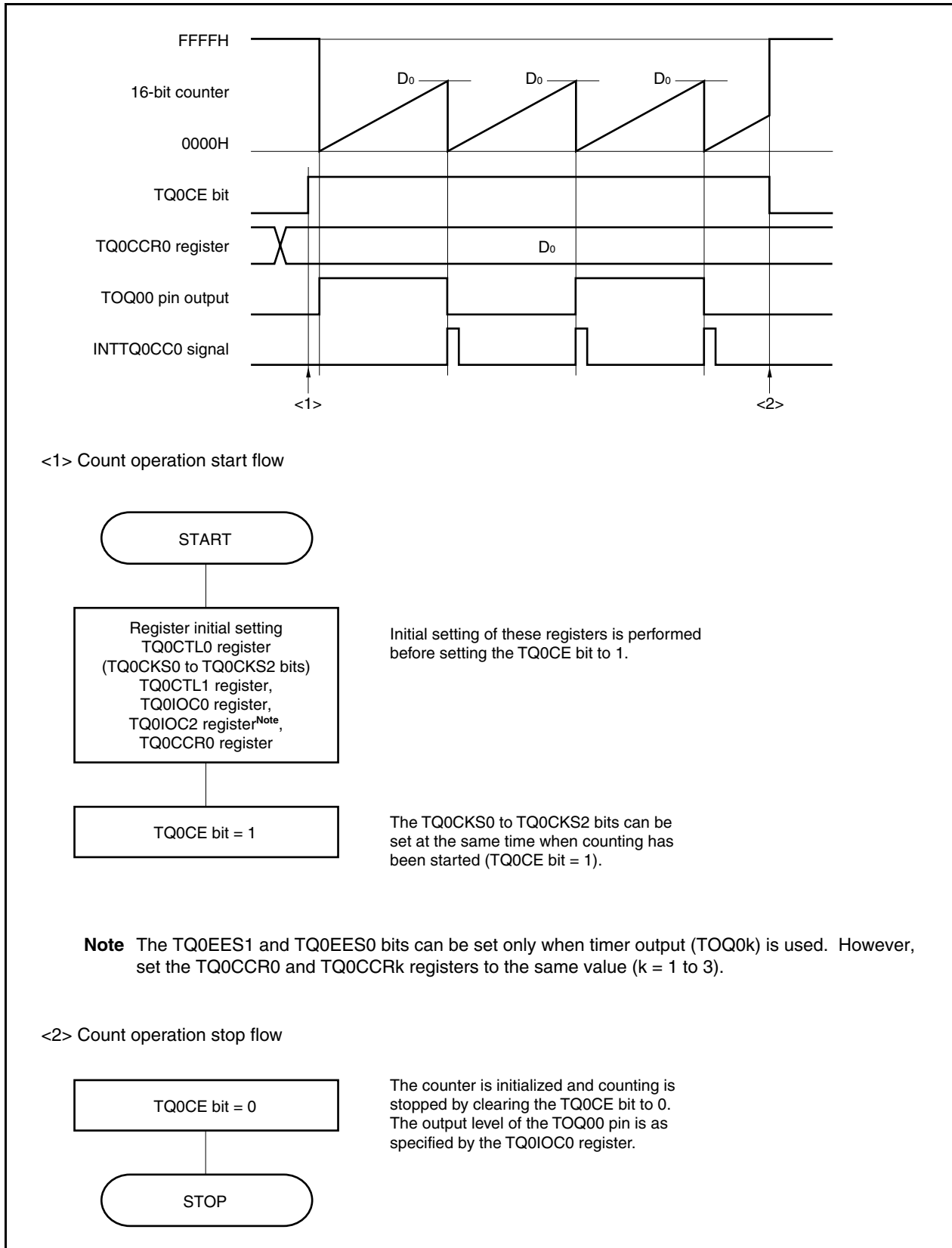



(2) Interval timer mode operation timing

(a) Operation if TQ0CCR0 register is set to 0000H

If the TQ0CCR0 register is set to 0000H, the INTTQ0CC0 signal is generated at each count clock, and the output of the TOQ00 pin is inverted.

The value of the 16-bit counter is always 0000H.

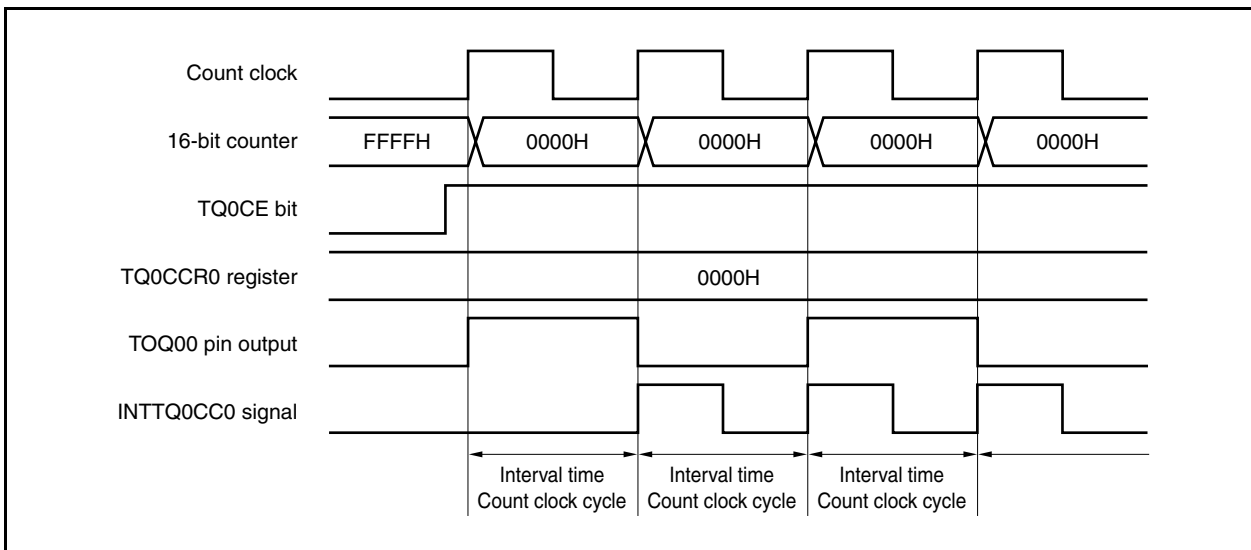

(b) Operation if TQ0CCR0 register is set to FFFFH

If the TQ0CCR0 register is set to FFFFH, the 16-bit counter counts up to FFFFH. The counter is cleared to 0000H in synchronization with the next count-up timing. The INTTQ0CC0 signal is generated and the output of the TOQ00 pin is inverted. At this time, an overflow interrupt request signal (INTTQ0OV) is not generated, nor is the overflow flag (TQ0OPT0.TQ0OVF bit) set to 1.

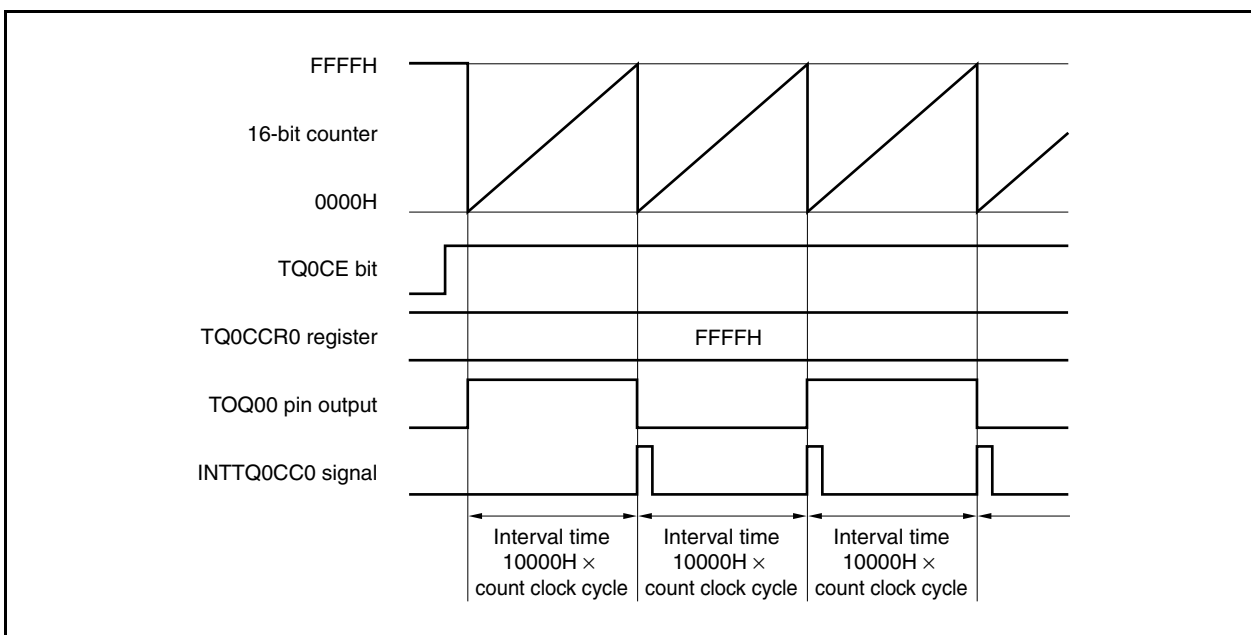

**(c) Notes on rewriting TQ0CCR0 register**

If the value of the TQ0CCR0 register is rewritten to a smaller value during counting, the 16-bit counter may overflow. If there is a possibility of overflow, stop counting and then change the set value.

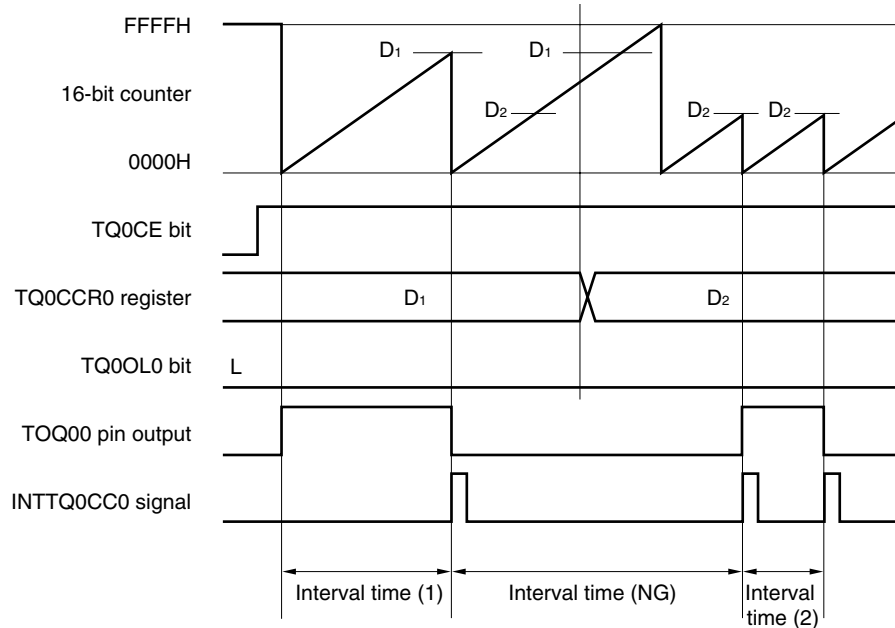

**Remark** Interval time (1):  $(D_1 + 1) \times \text{Count clock cycle}$   
Interval time (NG):  $(10000H + D_2 + 1) \times \text{Count clock cycle}$   
Interval time (2):  $(D_2 + 1) \times \text{Count clock cycle}$

If the value of the TQ0CCR0 register is changed from  $D_1$  to  $D_2$  while the count value is greater than  $D_2$  but less than  $D_1$ , the count value is transferred to the CCR0 buffer register as soon as the TQ0CCR0 register has been rewritten. Consequently, the value of the 16-bit counter that is compared is  $D_2$ .

Because the count value has already exceeded  $D_2$ , however, the 16-bit counter counts up to FFFFH, overflows, and then counts up again from 0000H. When the count value matches  $D_2$ , the INTTQ0CC0 signal is generated and the output of the TOQ00 pin is inverted.

Therefore, the INTTQ0CC0 signal may not be generated at the interval time " $(D_1 + 1) \times \text{Count clock cycle}$ " or " $(D_2 + 1) \times \text{Count clock cycle}$ " originally expected, but may be generated at an interval of " $(10000H + D_2 + 1) \times \text{Count clock period}$ ".

(d) Operation of TQ0CCR1 to TQ0CCR3 registers

Figure 8-10. Configuration of TQ0CCR1 to TQ0CCR3 Registers

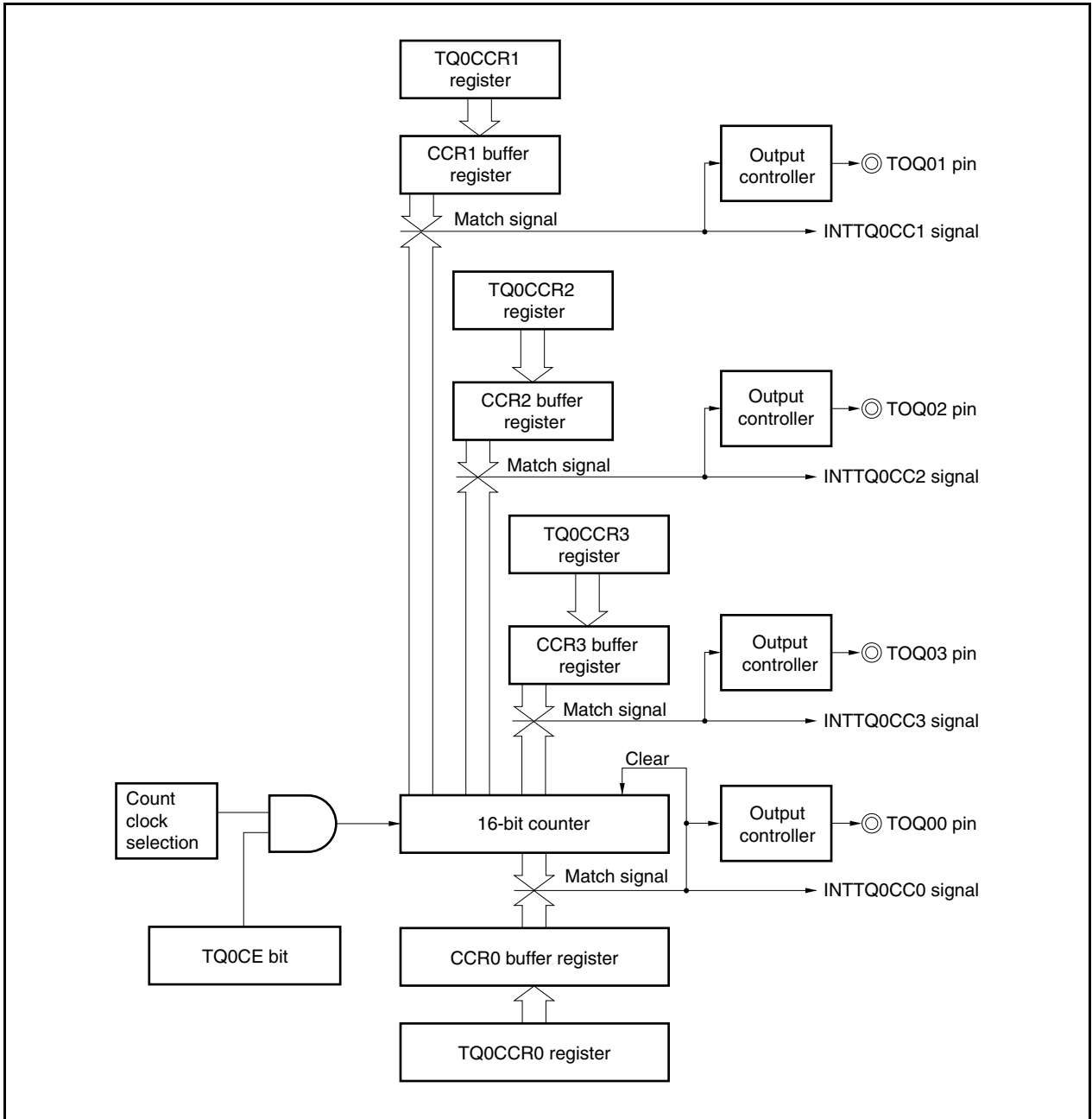

If the same value as the set value of the TQ0CCR0 register is set to the TQ0CCRk register, the INTTQ0CCk signal is generated together with the INTTQ0CC0 signal, and the output of the TOQ0k pin is inverted. This means that a square wave with a duty factor of 50% can be output from the TOQ0k pin.

If a value different from the set value of the TQ0CCR0 register is set to the TQ0CCRk register, the operation is as follows.

If the set value of the TQ0CCRk register is less than the set value of the TQ0CCR0 register, the INTTQ0CCk signal is generated once per cycle. At the same time, the output of the TOQ0k pin is inverted. The TOQ0k pin outputs a square wave with a duty factor of 50% after it first outputs a short-width pulse.

**Remark** k = 1 to 3

Figure 8-11. Timing Chart When  $D_{01} \geq D_{k1}$

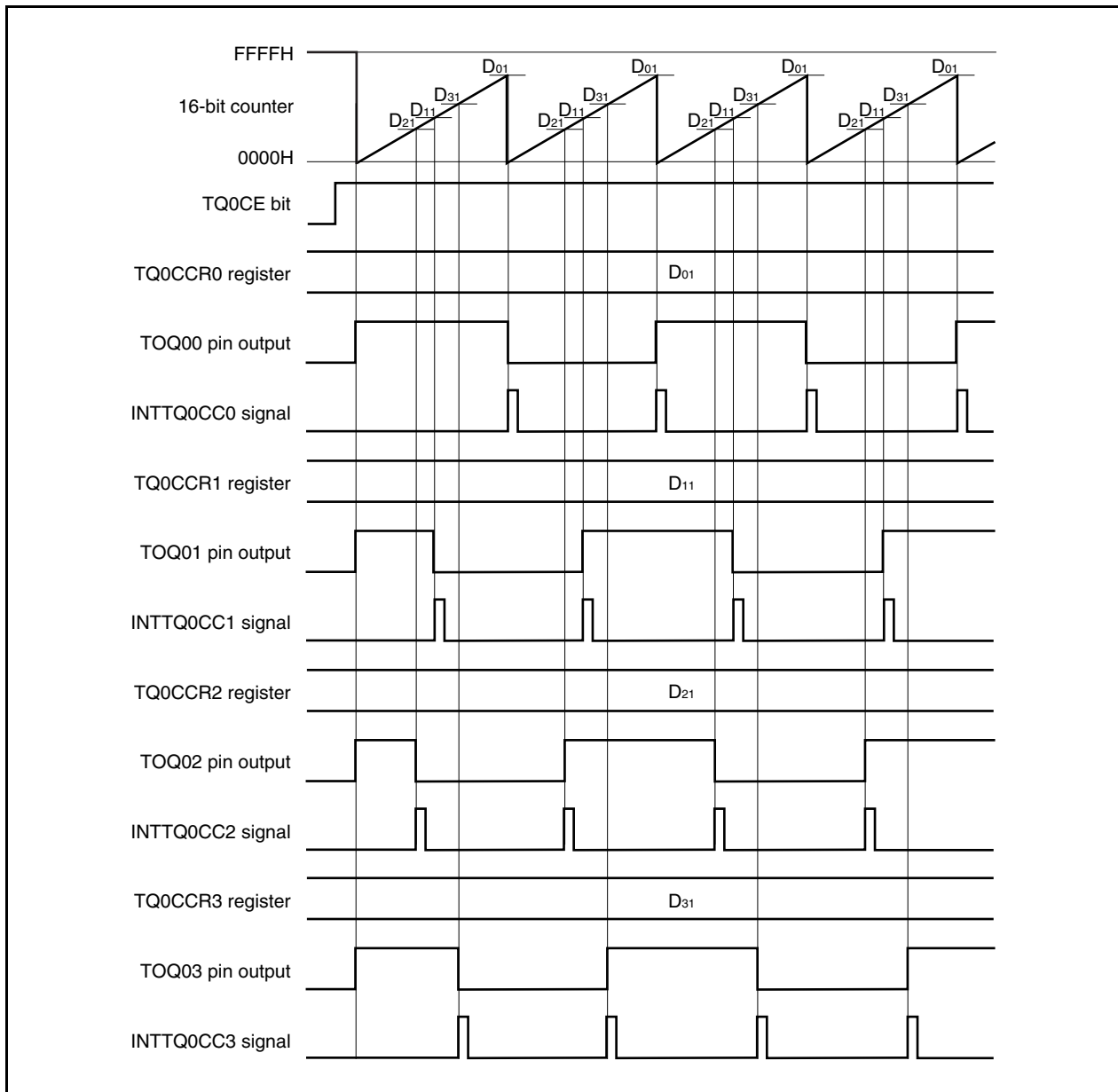

If the set value of the TQ0CCRk register is greater than the set value of the TQ0CCR0 register, the count value of the 16-bit counter does not match the value of the TQ0CCRk register. Consequently, the INTTQ0CCk signal is not generated, nor is the output of the TOQ0k pin changed. It is recommended to set FFFFH to the TQ0CCRk register when the TQ0CCRk register is not used.

**Remark** k = 1 to 3

**Figure 8-12. Timing Chart When  $D_{01} < D_{k1}$**

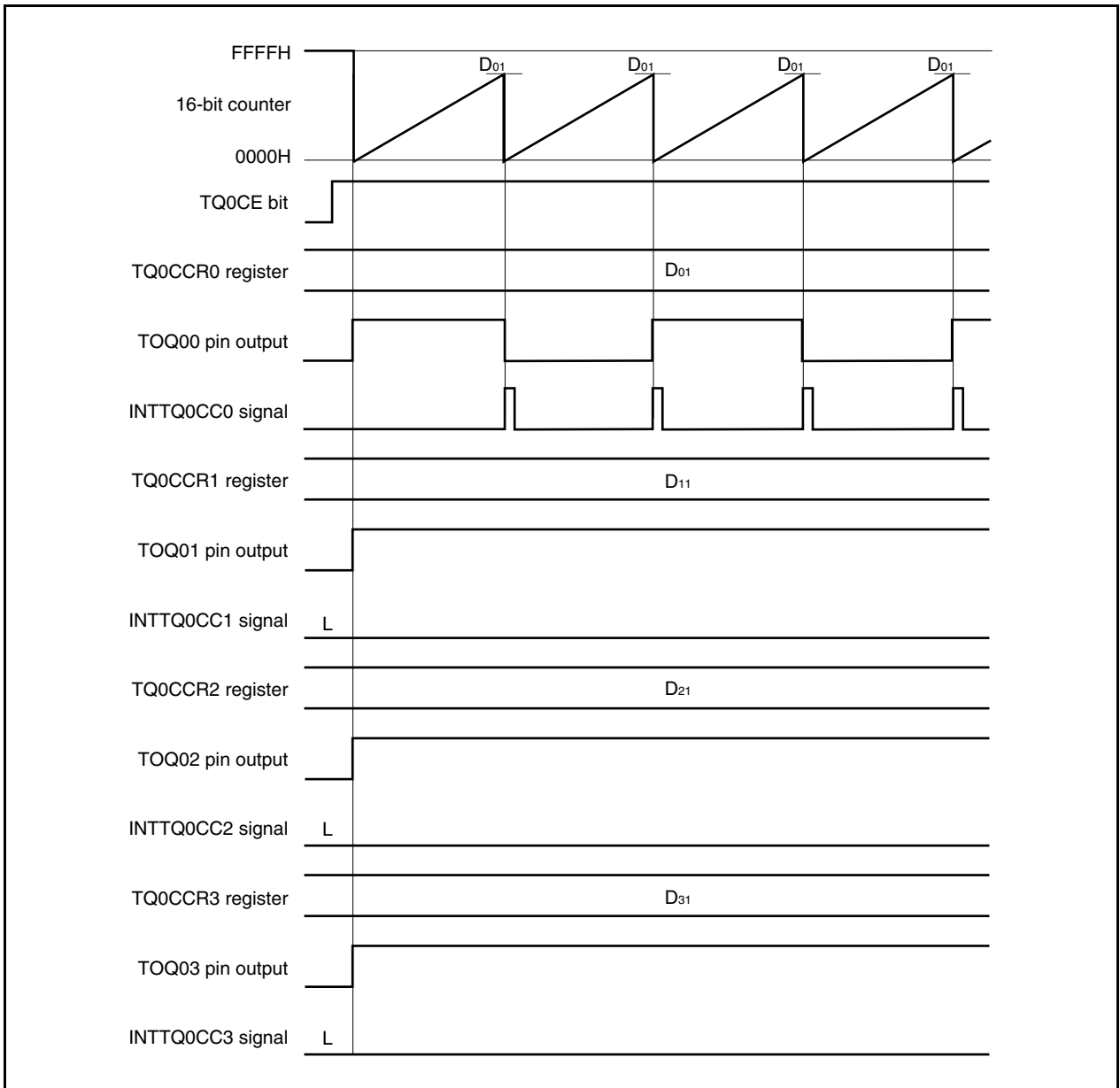

**(3) Operation by external event count input (TIQ00)**

**(a) Operation**

To count the 16-bit counter at the valid edge of external event count input (TIQ00) in the interval timer mode, the valid edge of the external event count input is necessary once because the 16-bit counter is cleared from FFFFH to 0000H immediately after the TQ0CE bit is set from 0 to 1.

When 0001H is set to both the TQ0CCR0 and TQ0CCRk registers, the output of the TOQ0k pins is inverted each time the 16-bit counter counts twice (k = 1 to 3).

The TQ0CTL0.TQ0EEE bit can be set to 1 in the interval timer mode only when the timer output (TOQ0k) is used with the external event count input.

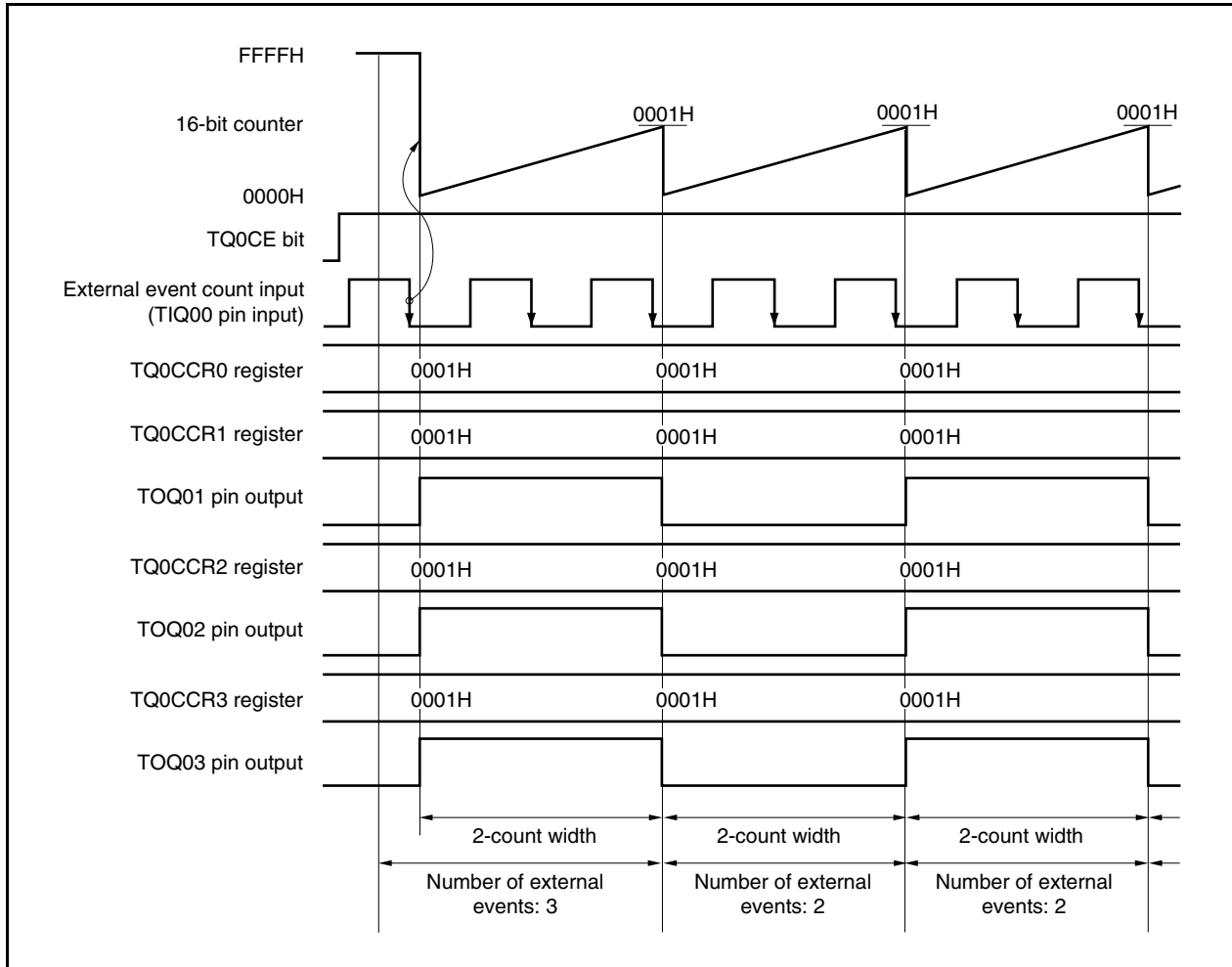

### 8.6.2 External event count mode (TQ0MD2 to TQ0MD0 bits = 001)

In the external event count mode, the valid edge of the external event count input (TIQ00) is counted when the TQ0CTL0.TQ0CE bit is set to 1, and an interrupt request signal (INTTQ0CC0) is generated each time the specified number of edges set by the TQ0CCR0 register have been counted. The TOQ00 to TOQ03 pins cannot be used. When using the TOQ01 and TOQ03 pins for external event count input, set the TQ0CTL1.TQ0EEE bit to 1 in the interval timer mode (see 8.6.1 (3) Operation by external event count input (TIQ00)).

The TQ0CCR1 to TQ0CCR3 registers are not used in the external event count mode.

**Caution** In the external event count mode, the TQ0CCR0 to TQ0CCR3 registers must not be cleared to 0000H.

Figure 8-13. Configuration in External Event Count Mode

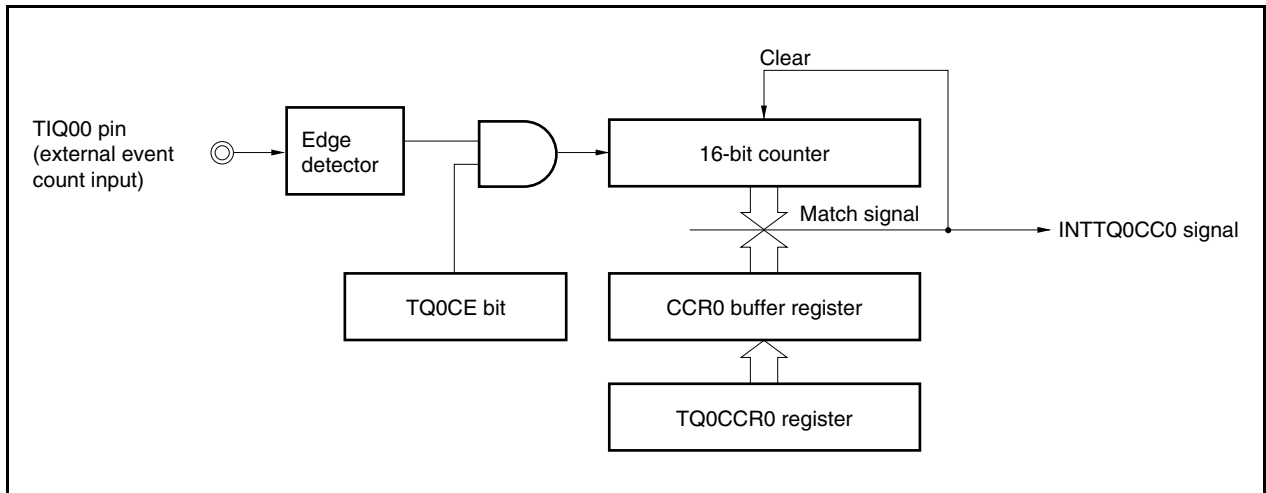
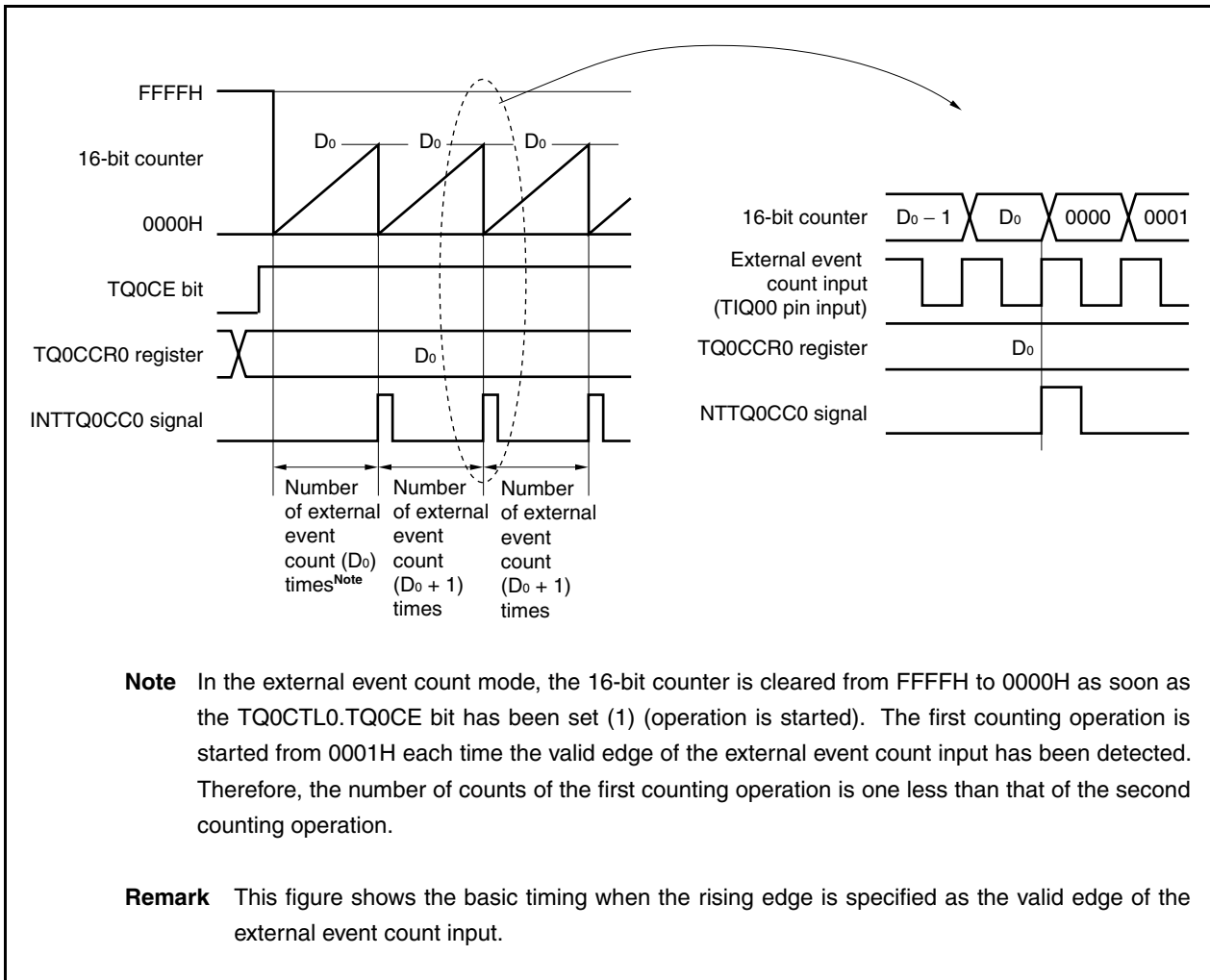

Figure 8-14. Basic Timing in External Event Count Mode



**Note** In the external event count mode, the 16-bit counter is cleared from FFFFH to 0000H as soon as the TQ0CTL0.TQ0CE bit has been set (1) (operation is started). The first counting operation is started from 0001H each time the valid edge of the external event count input has been detected. Therefore, the number of counts of the first counting operation is one less than that of the second counting operation.

**Remark** This figure shows the basic timing when the rising edge is specified as the valid edge of the external event count input.



When the TQ0CE bit is set to 1, the value of the 16-bit counter is cleared from FFFFH to 0000H. The counter counts each time the valid edge of external event count input is detected. Additionally, the set value of the TQ0CCR0 register is transferred to the CCR0 buffer register.

When the count value of the 16-bit counter matches the value of the CCR0 buffer register, the 16-bit counter is cleared to 0000H, and a compare match interrupt request signal (INTTQ0CC0) is generated.

The INTTQ0CC0 signal is generated for the first time when the valid edge of the external event count input has been detected “value set to TQ0CCR0 register” times. After that, the INTTQ0CC0 signal is generated each time the valid edge of the external event count has been detected “value set to TQ0CCR0 register + 1” times.

Figure 8-15. Register Setting for Operation in External Event Count Mode (1/2)

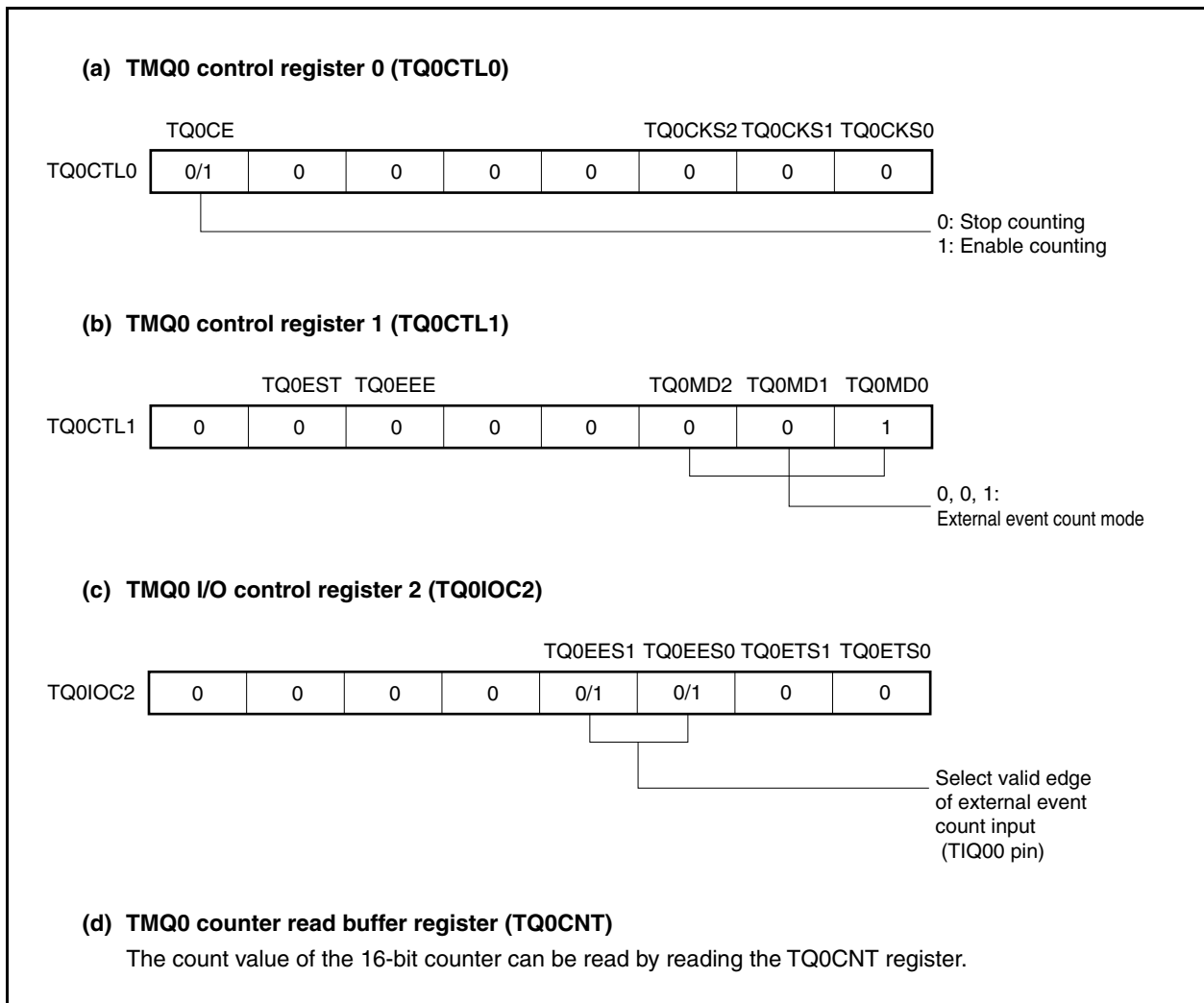

Figure 8-15. Register Setting for Operation in External Event Count Mode (2/2)

**(e) TMQ0 capture/compare register 0 (TQ0CCR0)**

If the TQ0CCR0 register is set to  $D_0$ , the count is cleared when the number of external events has reached  $(D_0)$  and the first compare match interrupt request signal (INTTQ0CC0) is generated. The second compare match interrupt request signal (INTTQ0CC0) is generated when the number of external events has reached  $(D_0 + 1)$ .

**(f) TMQ0 capture/compare registers 1 to 3 (TQ0CCR1 to TQ0CCR3)**

The TQ0CCR1 to TQ0CCR3 registers are not used in the external event count mode. However, the set value of the TQ0CCR1 to TQ0CCR3 registers are transferred to the CCR1 to CCR3 buffer registers. When the count value of the 16-bit counter matches the value of the CCR1 to CCR3 buffer registers, compare match interrupt request signals (INTTQ0CC1 to INTTQ0CC3) are generated.

When the TQ0CCR1 to TQ0CCR3 registers are not used, it is recommended to set their values to FFFFH. Also mask the registers by the interrupt mask flags (TQ0CCIC1.TQ0CCMK1 to TQ0CCIC3.TQ0CCMK3).

**Cautions** 1. Set the TQ0IOC0 register to 00H.

2. When an external clock is used as the count clock, the external clock can be input only from the TIQ00 pin. At this time, set the TQ0IOC1.TQ0IS1 and TQ0IOC1.TQ0IS0 bits to 00 (capture trigger input (TIQ00 pin): no edge detection).

**Remark** The TMQ0 I/O control register 1 (TQ0IOC1) and TMQ0 option register 0 (TQ0OPT0) are not used in the external event count mode.

(1) External event count mode operation flow

Figure 8-16. Flow of Software Processing in External Event Count Mode

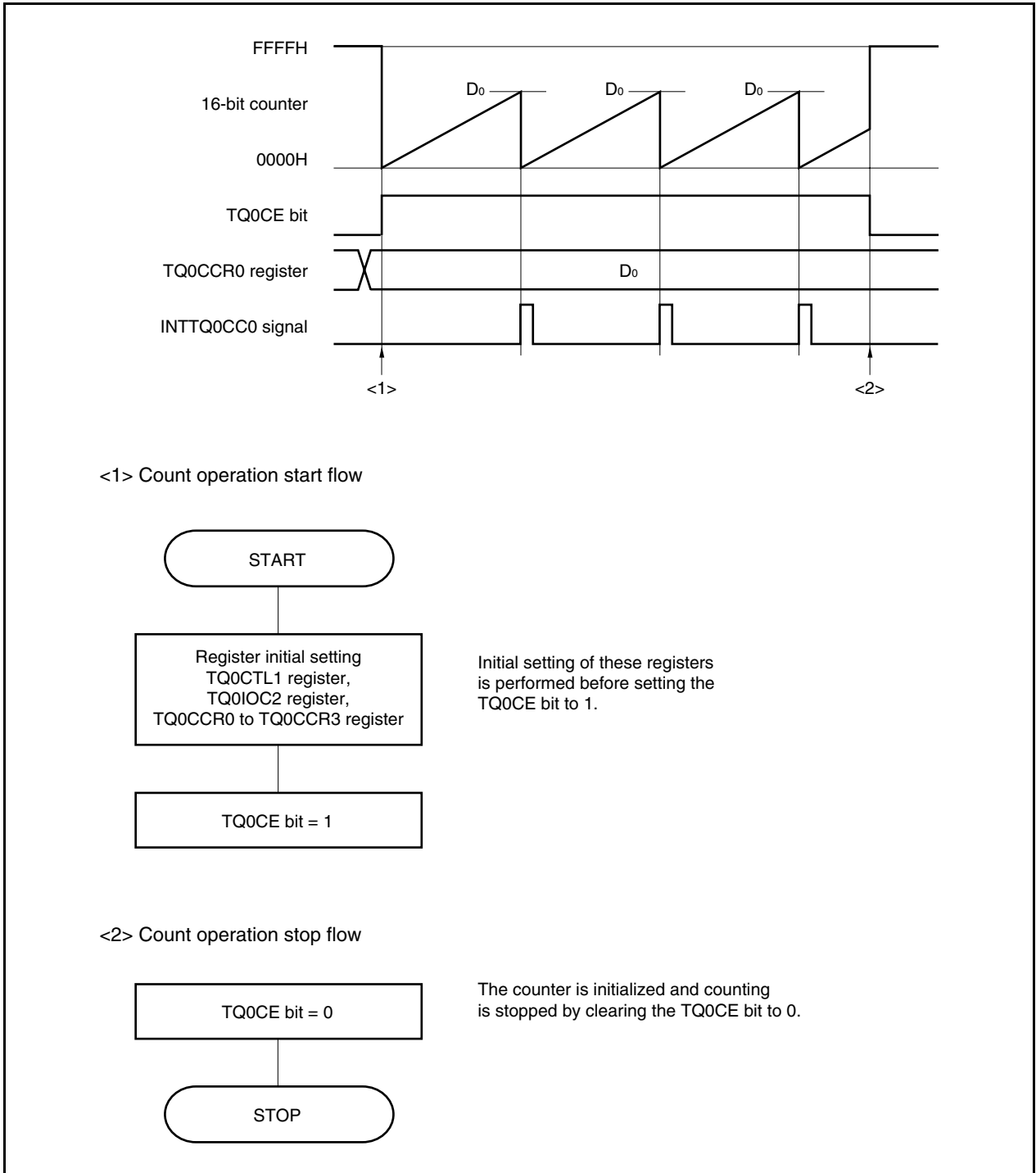

## (2) Operation timing in external event count mode

- Cautions**
1. In the external event count mode, setting the TQ0CCR0 to TQ0CCR3 registers to 0000H is disabled.
  2. In the external event count mode, use of the timer output (TOQ00 to TOQ03) is disabled. If performing external event count input (TIQ00) using the timer outputs (TOQ01 to TOQ03), set the interval timer mode to enable the count clock operation (TQ0CTL1.TQ0EEE bit = 1) for the external event count input (refer to 8.6.1 (3) Operation by external event count input (TIQ00)).

## (a) Operation if TQ0CCR0 register is set to FFFFH

If the TQ0CCR0 register is set to FFFFH, the 16-bit counter counts to FFFFH each time the valid edge of the external event count signal has been detected. The 16-bit counter is cleared to 0000H in synchronization with the next count-up timing, and the INTTQ0CC0 signal is generated. At this time, the TQ0OPT0.TQ0OVF bit is not set.

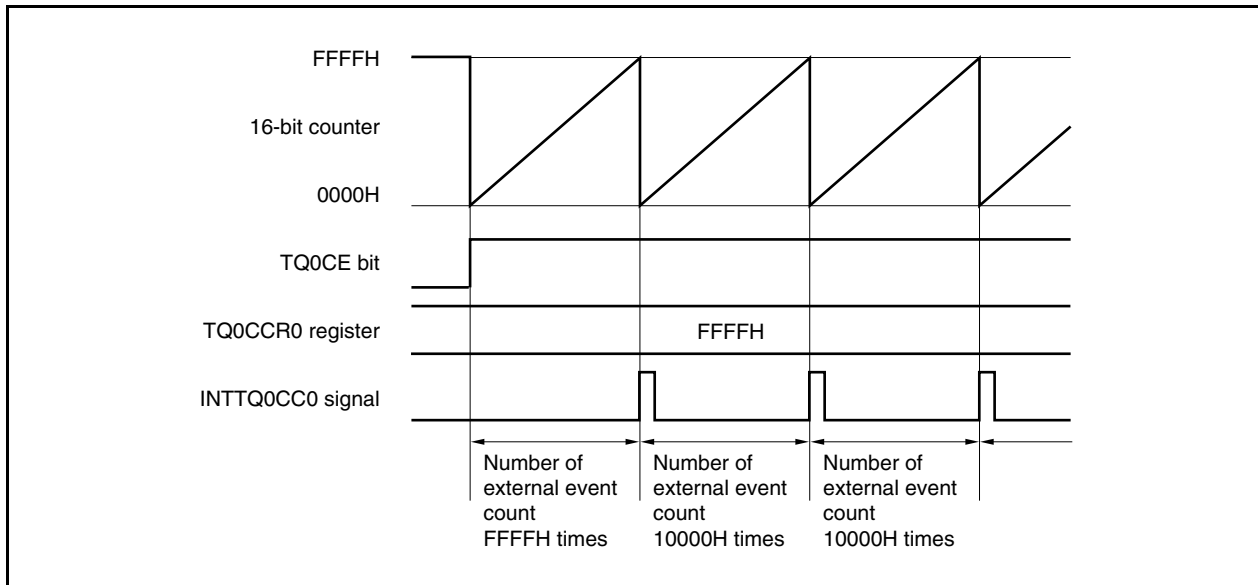

**(b) Notes on rewriting the TQ0CCR0 register**

If the value of the TQ0CCR0 register is rewritten to a smaller value during counting, the 16-bit counter may overflow. If there is a possibility of overflow, stop counting and then change the set value.

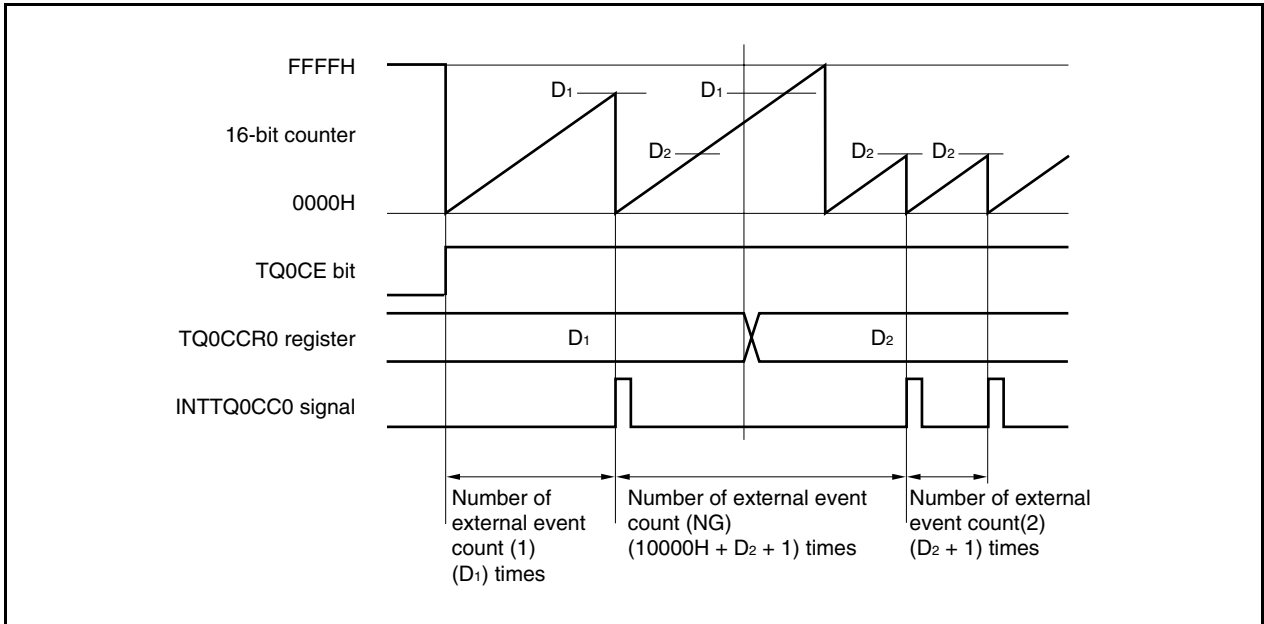

If the value of the TQ0CCR0 register is changed from D<sub>1</sub> to D<sub>2</sub> while the count value is greater than D<sub>2</sub> but less than D<sub>1</sub>, the count value is transferred to the CCR0 buffer register as soon as the TQ0CCR0 register has been rewritten. Consequently, the value that is compared with the 16-bit counter is D<sub>2</sub>.

Because the count value has already exceeded D<sub>2</sub>, however, the 16-bit counter counts up to FFFFH, overflows, and then counts up again from 0000H. When the count value matches D<sub>2</sub>, the INTTQ0CC0 signal is generated.

Therefore, the INTTQ0CC0 signal may not be generated at the valid edge count of “(D<sub>1</sub> + 1) times” or “(D<sub>2</sub> + 1) times” originally expected, but may be generated at the valid edge count of “(10000H + D<sub>2</sub> + 1) times”.

(c) Operation of TQ0CCR1 to TQ0CCR3 registers

Figure 8-17. Configuration of TQ0CCR1 to TQ0CCR3 Registers

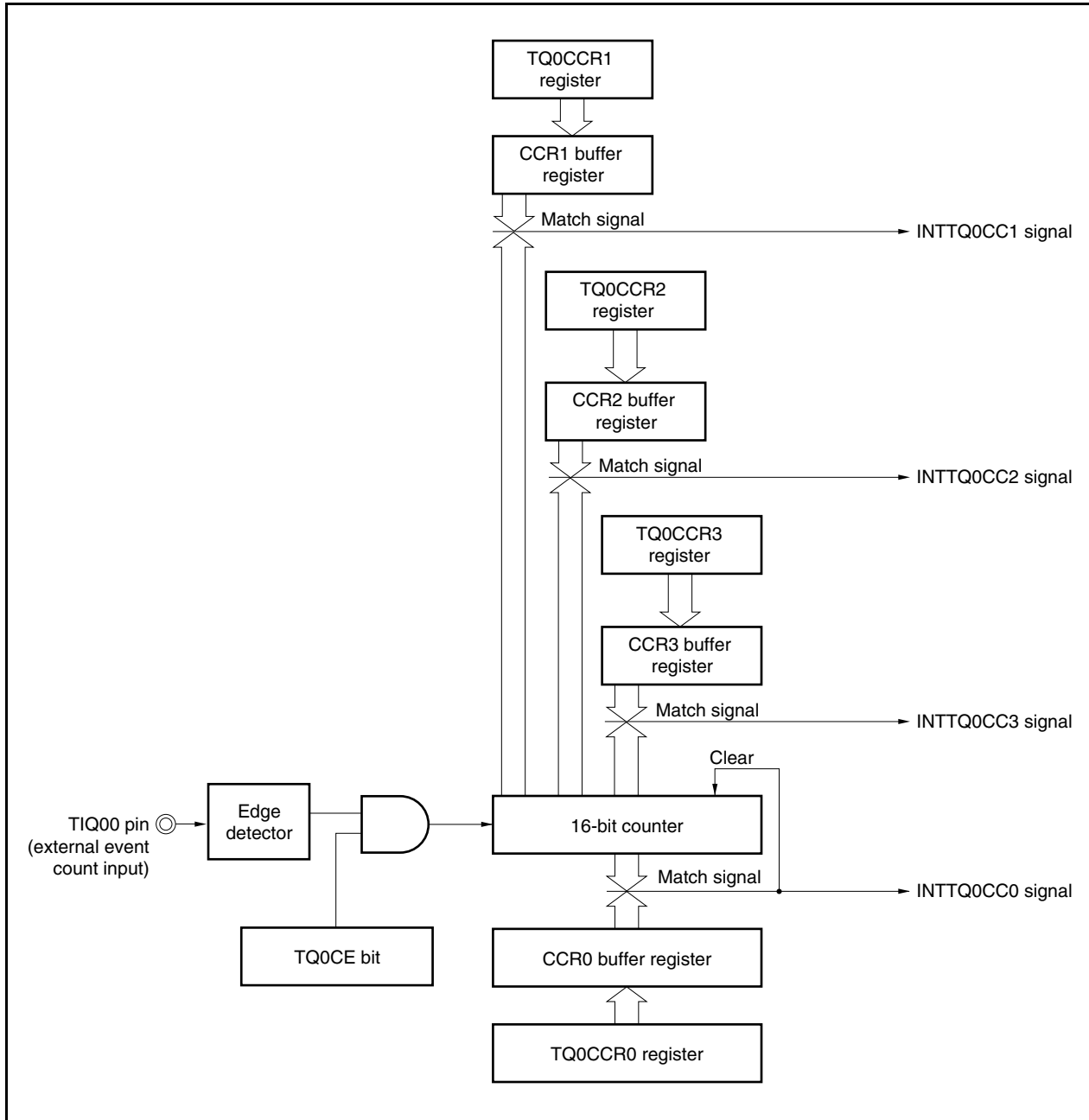

If the set value of the TQ0CCRk register is smaller than the set value of the TQ0CCR0 register, the INTTQ0CCk signal is generated once per cycle.

**Remark** k = 1 to 3

**Figure 8-18. Timing Chart When  $D_{01} \geq D_{k1}$**

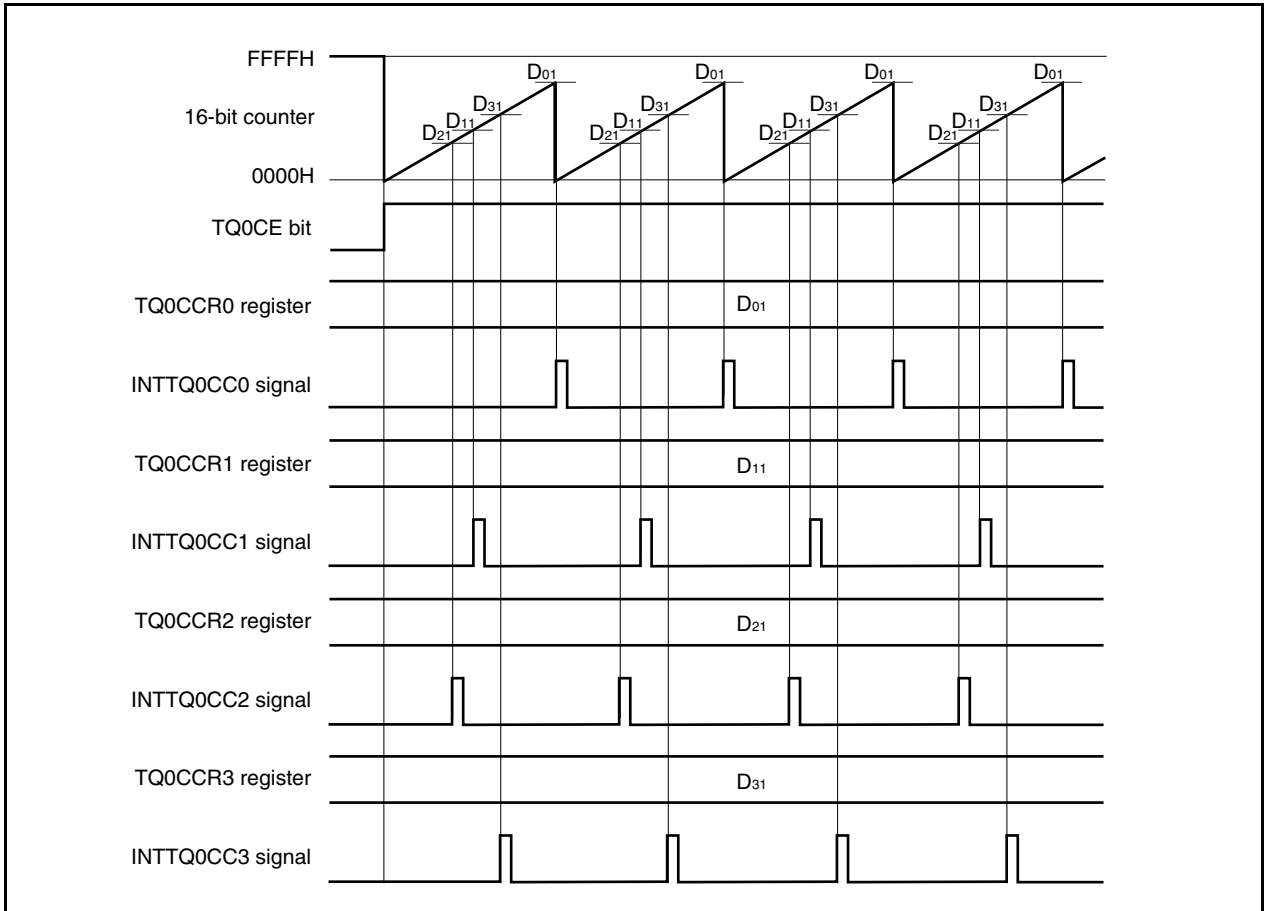

If the set value of the TQ0CCRk register is greater than the set value of the TQ0CCR0 register, the INTTQ0CCk signal is not generated because the count value of the 16-bit counter and the value of the TQ0CCRk register do not match.

It is recommended to set FFFFH to the TQ0CCRk register when the TQ0CCRk register is not used.

**Remark** k = 1 to 3

**Figure 8-19. Timing Chart When  $D_{01} < D_{k1}$**

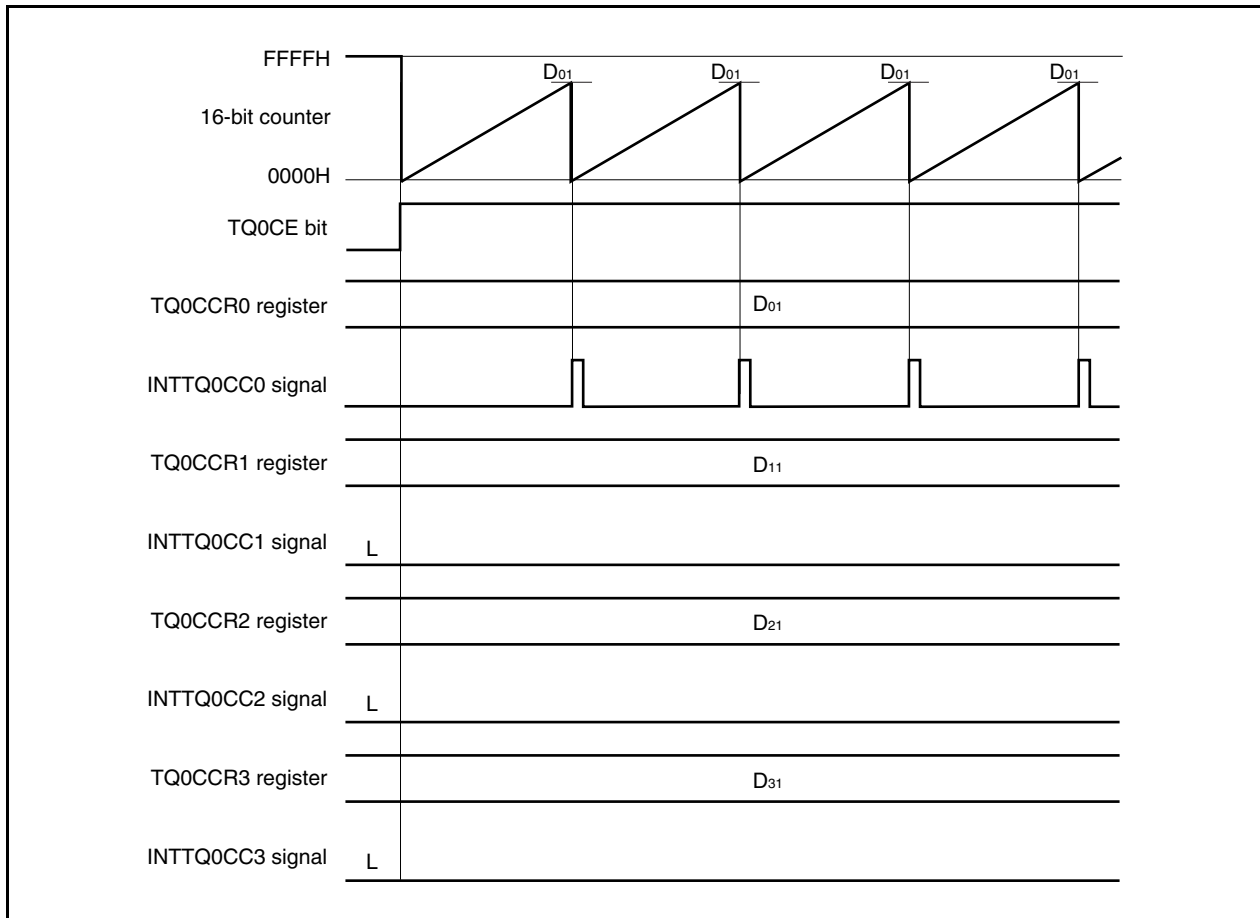



### 8.6.3 External trigger pulse output mode (TQ0MD2 to TQ0MD0 bits = 010)

In the external trigger pulse output mode, 16-bit timer/event counter Q waits for a trigger when the TQ0CTL0.TQ0CE bit is set to 1. When the valid edge of an external trigger input signal (TIQ00) is detected, 16-bit timer/event counter Q starts counting, and outputs a PWM waveform from the TOQ01 to TOQ03 pins.

Pulses can also be output by generating a software trigger instead of using the external trigger. When using a software trigger, a square wave with a duty factor of 50% whose half cycle is the set value of the TQ0CCR0 register + 1 can also be output from the TOQ00 pin.

Figure 8-20. Configuration in External Trigger Pulse Output Mode

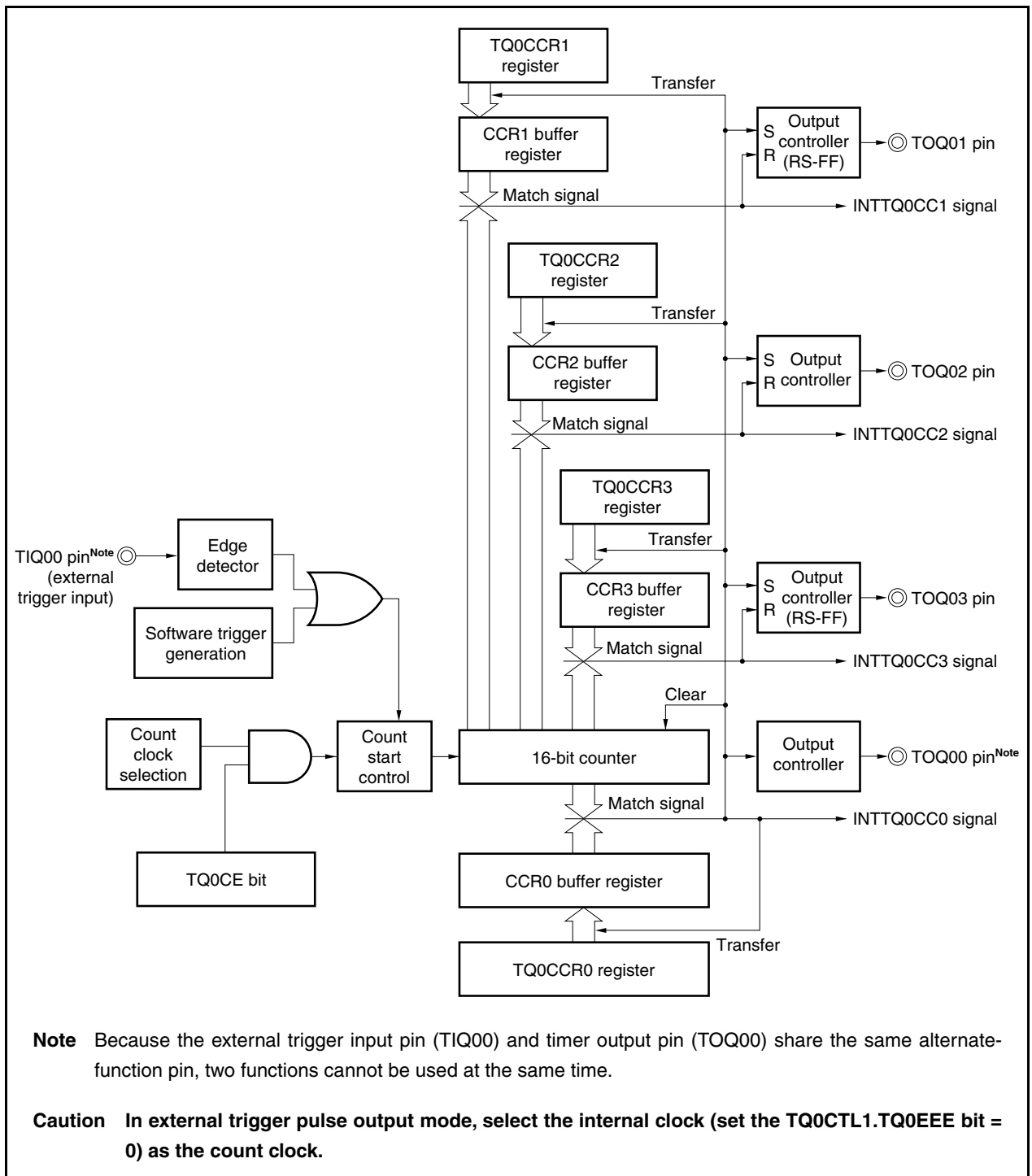
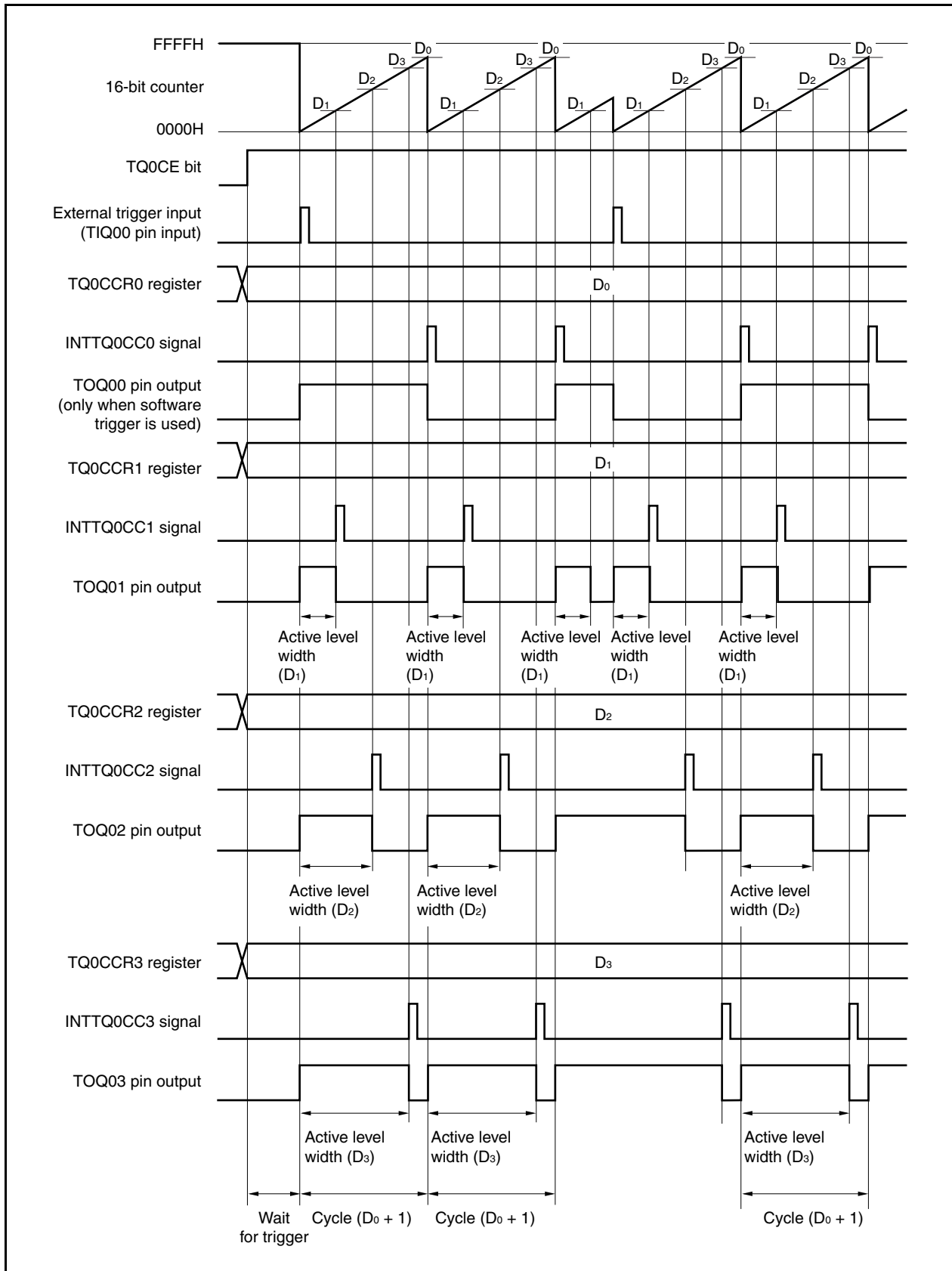

Figure 8-21. Basic Timing in External Trigger Pulse Output Mode



16-bit timer/event counter Q waits for a trigger when the TQ0CE bit is set to 1. When the trigger is generated, the 16-bit counter is cleared from FFFFH to 0000H, starts counting at the same time, and outputs a PWM waveform from the TOQ0k pin. If the trigger is generated again while the counter is operating, the counter is cleared to 0000H and restarted. (The output of the TOQ00 pin is inverted. The TOQ0k pin outputs a high-level regardless of the status (high/low) when a trigger occurs.)

The active level width, cycle, and duty factor of the PWM waveform can be calculated as follows.

$$\text{Active level width} = (\text{Set value of TQ0CCRk register}) \times \text{Count clock cycle}$$

$$\text{Cycle} = (\text{Set value of TQ0CCR0 register} + 1) \times \text{Count clock cycle}$$

$$\text{Duty factor} = (\text{Set value of TQ0CCRk register}) / (\text{Set value of TQ0CCR0 register} + 1)$$

The compare match request signal INTTQ0CC0 is generated when the 16-bit counter counts next time after its count value matches the value of the CCR0 buffer register, and the 16-bit counter is cleared to 0000H. The compare match interrupt request signal INTTQ0CCk is generated when the count value of the 16-bit counter matches the value of the CCRk buffer register.

The value set to the TQ0CCRm register is transferred to the CCRm buffer register when the count value of the 16-bit counter matches the value of the CCR0 buffer register and the 16-bit counter is cleared to 0000H.

The valid edge of an external trigger input signal (TIQ00), or setting the software trigger (TQ0CTL1.TQ0EST bit) to 1 is used as the trigger.

**Remark** k = 1 to 3, m = 0 to 3

**Figure 8-22. Setting of Registers in External Trigger Pulse Output Mode (1/3)**

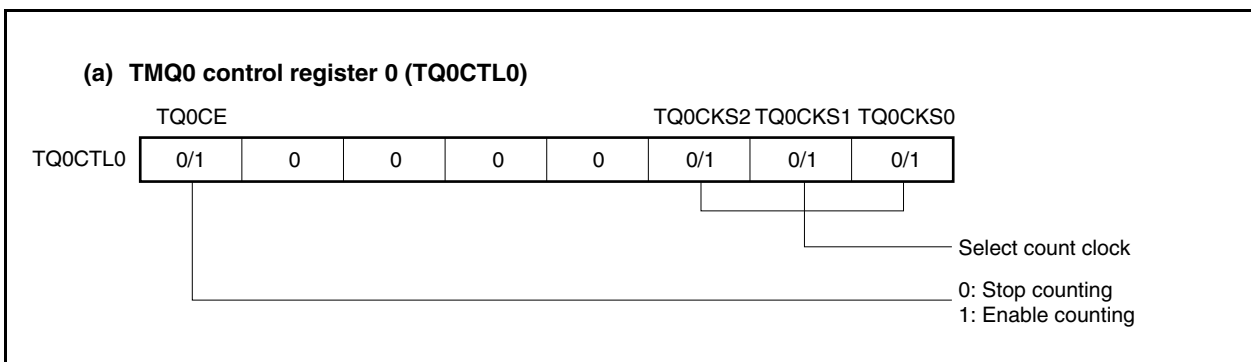
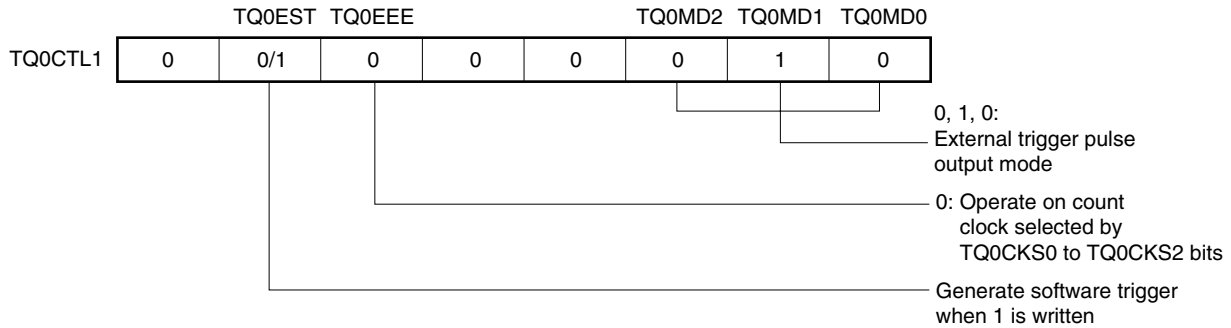
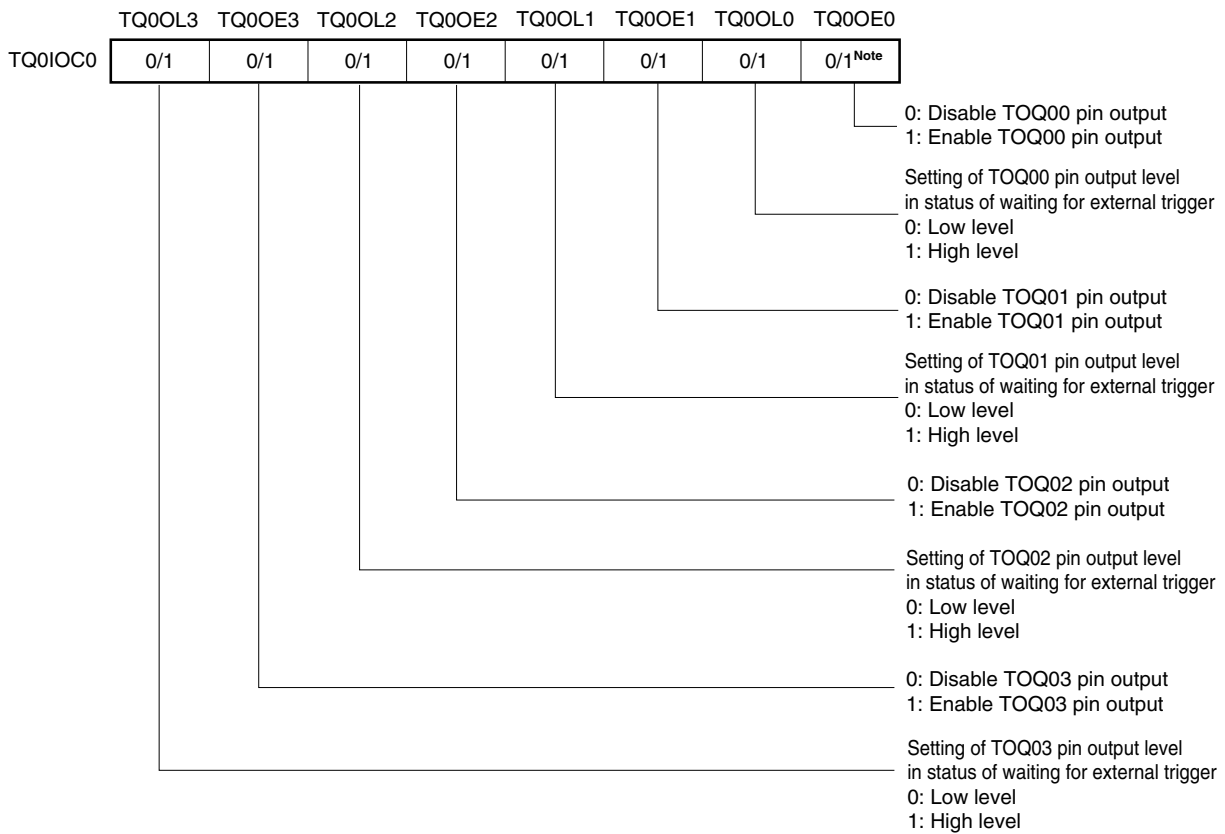

Figure 8-22. Setting of Registers in External Trigger Pulse Output Mode (2/3)

(b) TMQ0 control register 1 (TQ0CTL1)



(c) TMQ0 I/O control register 0 (TQ0IOC0)



• When TQ0OLk bit = 0

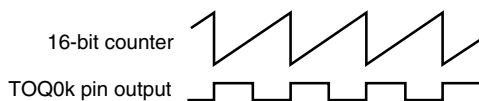

• When TQ0OLk bit = 1

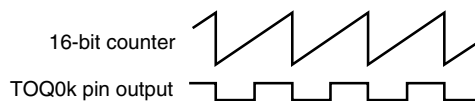

**Note** Clear this bit to 0 when the TOQ00 pin is not used in the external trigger pulse output mode.

Figure 8-22. Setting of Registers in External Trigger Pulse Output Mode (3/3)

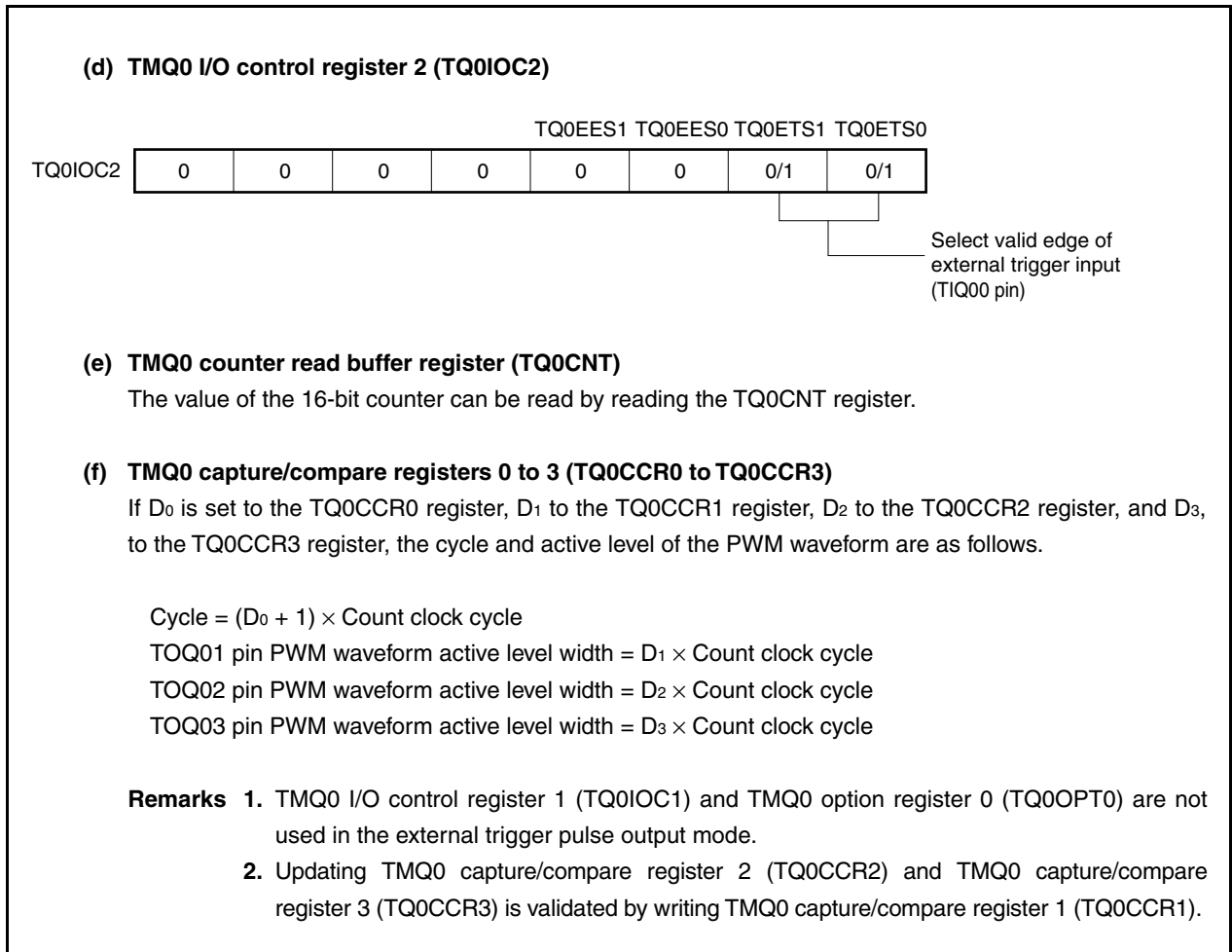

(1) Operation flow in external trigger pulse output mode

Figure 8-23. Software Processing Flow in External Trigger Pulse Output Mode (1/2)

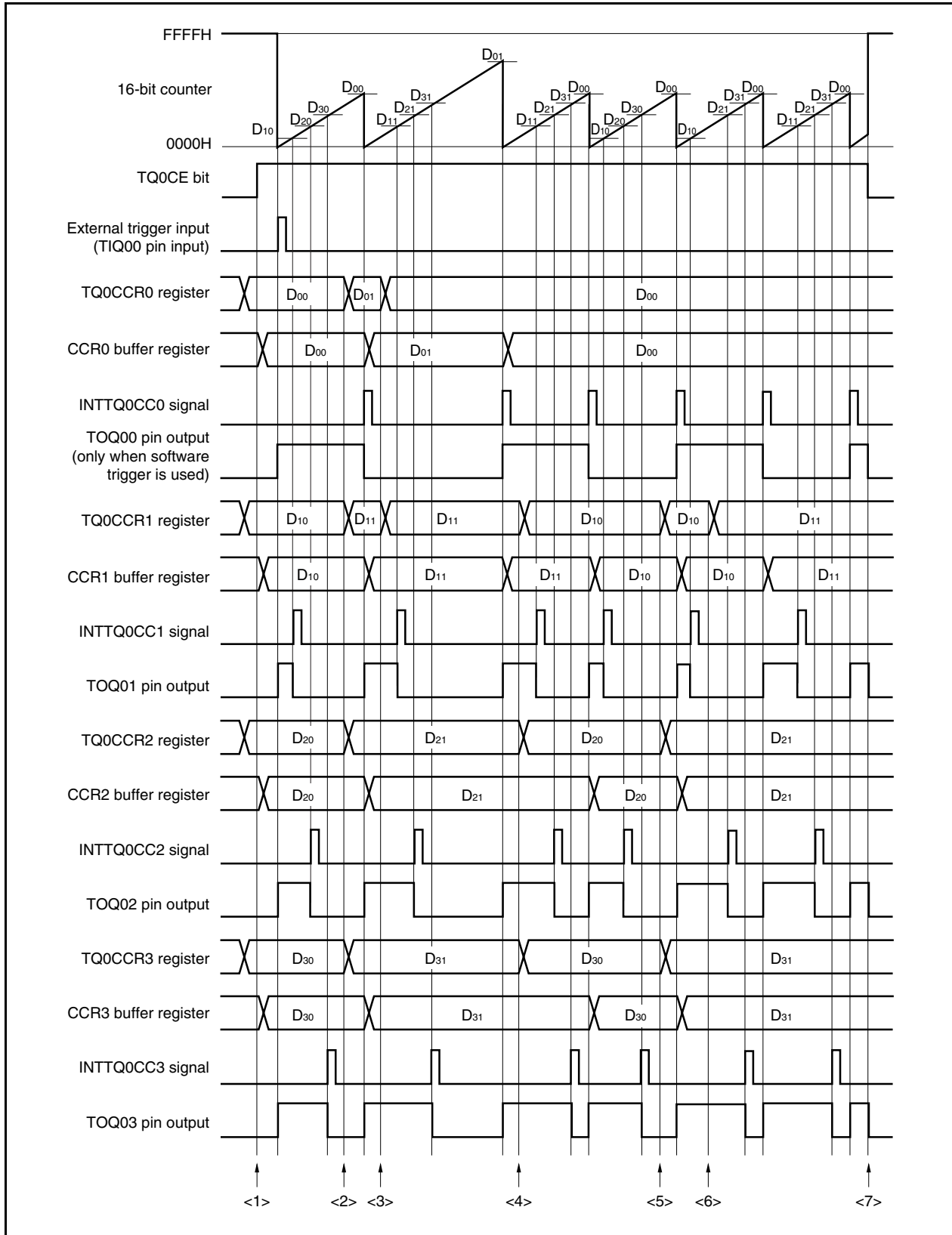
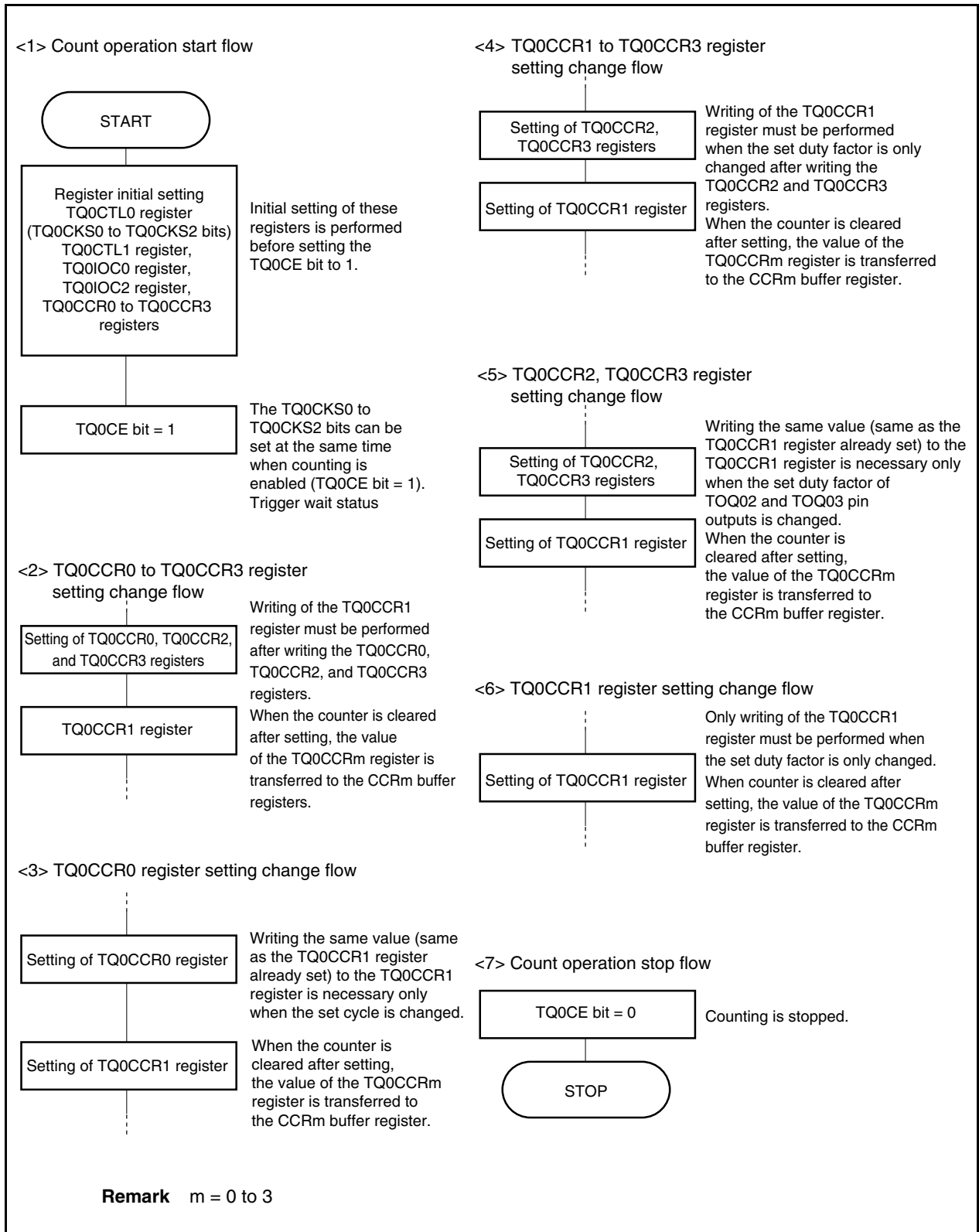

Figure 8-23. Software Processing Flow in External Trigger Pulse Output Mode (2/2)



(2) External trigger pulse output mode operation timing

(a) Note on changing pulse width during operation

To change the PWM waveform while the counter is operating, write the TQ0CCR1 register last.  
 Rewrite the TQ0CCRk register after writing the TQ0CCR1 register after the INTTQ0CC0 signal is detected.

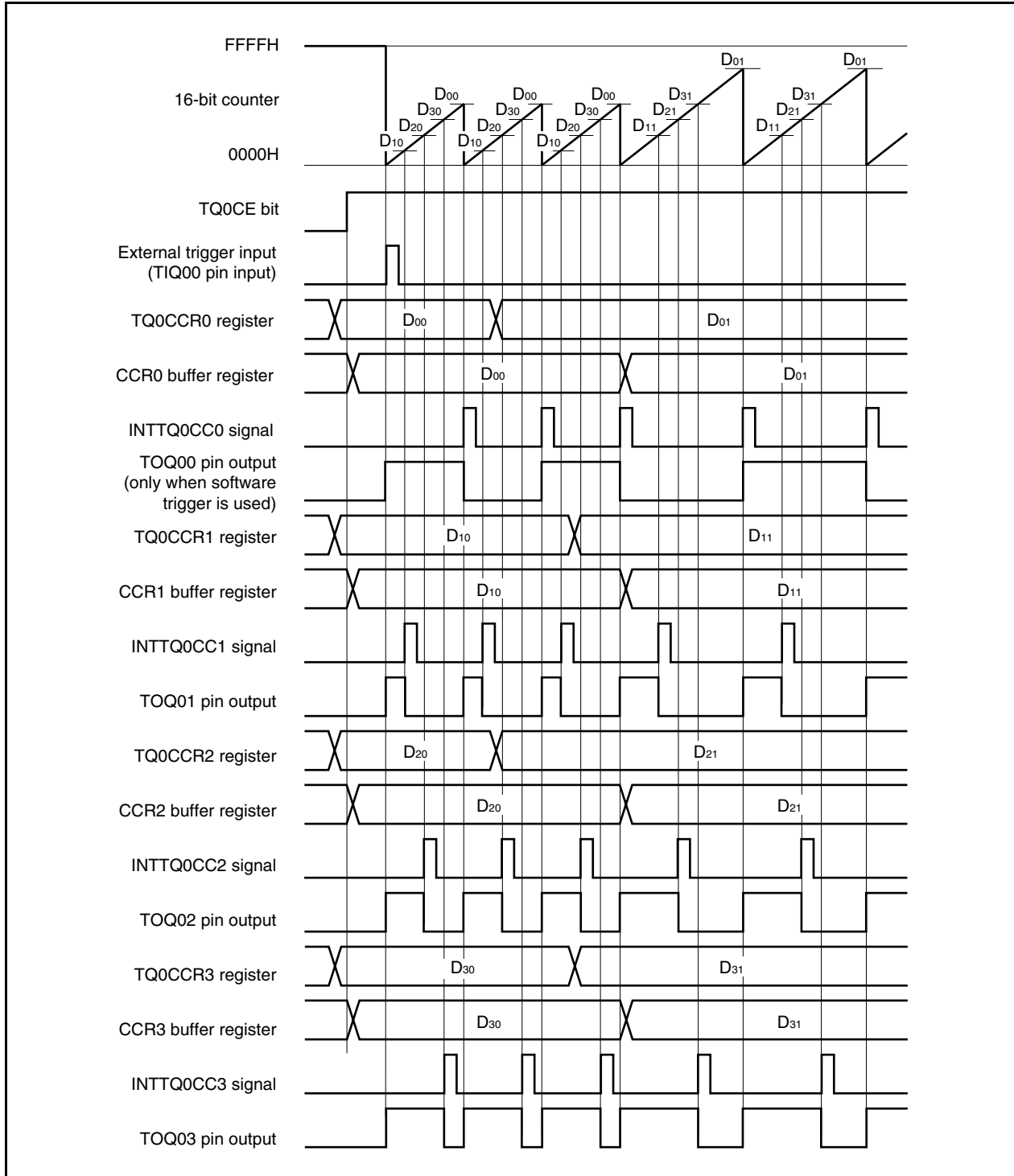



In order to transfer data from the TQ0CCRm register to the CCRm buffer register, the TQ0CCR1 register must be written.

To change both the cycle and active level width of the PWM waveform at this time, first set the cycle to the TQ0CCR0 register, set the active level width to the TQ0CCR2 and TQ0CCR3 registers, and then set an active level to the TQ0CCR1 register.

To change only the cycle of the PWM waveform, first set the cycle to the TQ0CCR0 register, and then write the same value (same as the TQ0CCR1 register already set) to the TQ0CCR1 register.

To change only the active level width (duty factor) of the PWM waveform, first set an active level to the TQ0CCR2 and TQ0CCR3 registers and then set an active level to the TQ0CCR1 register.

To change only the active level width (duty factor) of the PWM waveform output by the TOQ01 pin, only the TQ0CCR1 register has to be set.

To change only the active level width (duty factor) of the PWM waveform output by the TOQ02 and TOQ03 pins, first set an active level width to the TQ0CCR2 and TQ0CCR3 registers, and then write the same value (same as the TQ0CCR1 register already set) to the TQ0CCR1 register.

After data is written to the TQ0CCR1 register, the value written to the TQ0CCRm register is transferred to the CCRm buffer register in synchronization with clearing of the 16-bit counter, and is used as the value compared with the 16-bit counter.

To write the TQ0CCR0 to TQ0CCR3 registers again after writing the TQ0CCR1 register once, do so after the INTTQ0CC0 signal is generated. Otherwise, the value of the CCRm buffer register may become undefined because timing of transferring data from the TQ0CCRm register to the CCRm buffer register conflicts with writing the TQ0CCRm register.

**Remark** m = 0 to 3

**(b) 0%/100% output of PWM waveform**

To output a 0% waveform, set the TQ0CCRk register to 0000H. The 16-bit counter is cleared to 0000H and the INTTQ0CC0 and INTTQ0CCk signals are generated at the next timing after a match between the count value of the 16-bit counter and the value of the CCR0 buffer register.

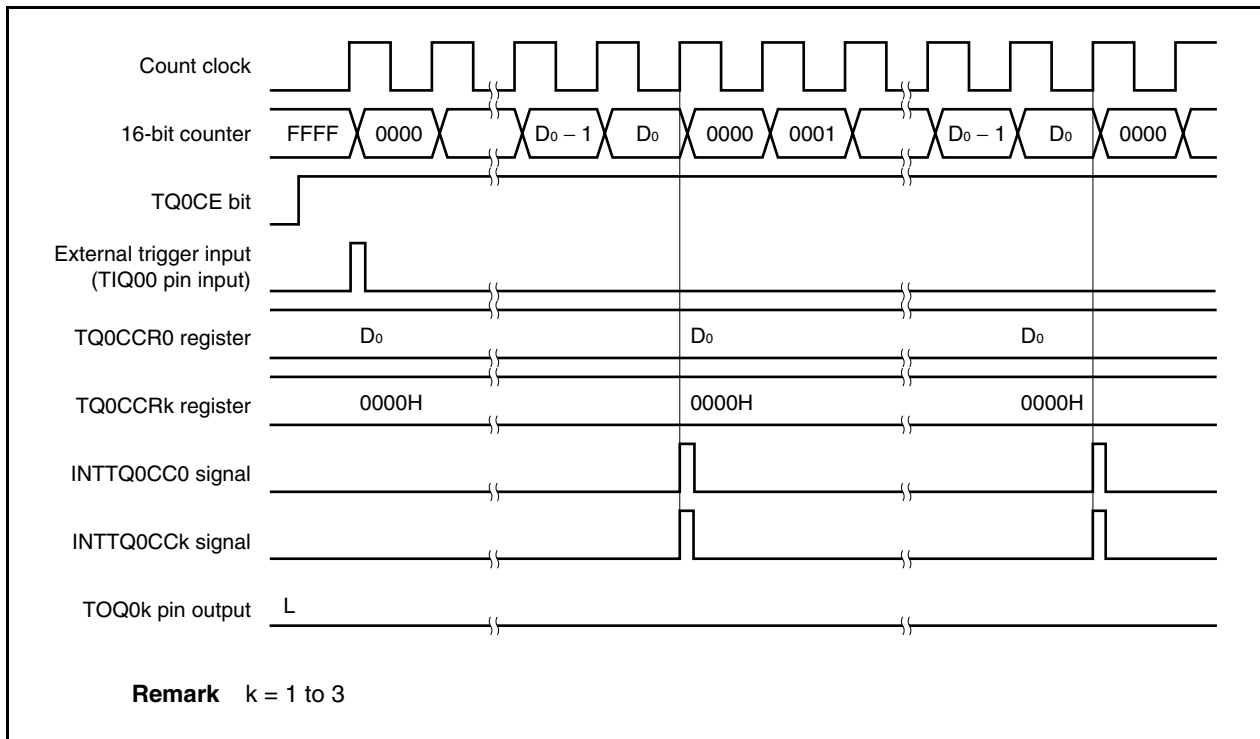

To output a 100% waveform, set a value of (set value of TQ0CCR0 register + 1) to the TQ0CCRk register. If the set value of the TQ0CCR0 register is FFFFH, 100% output cannot be produced.

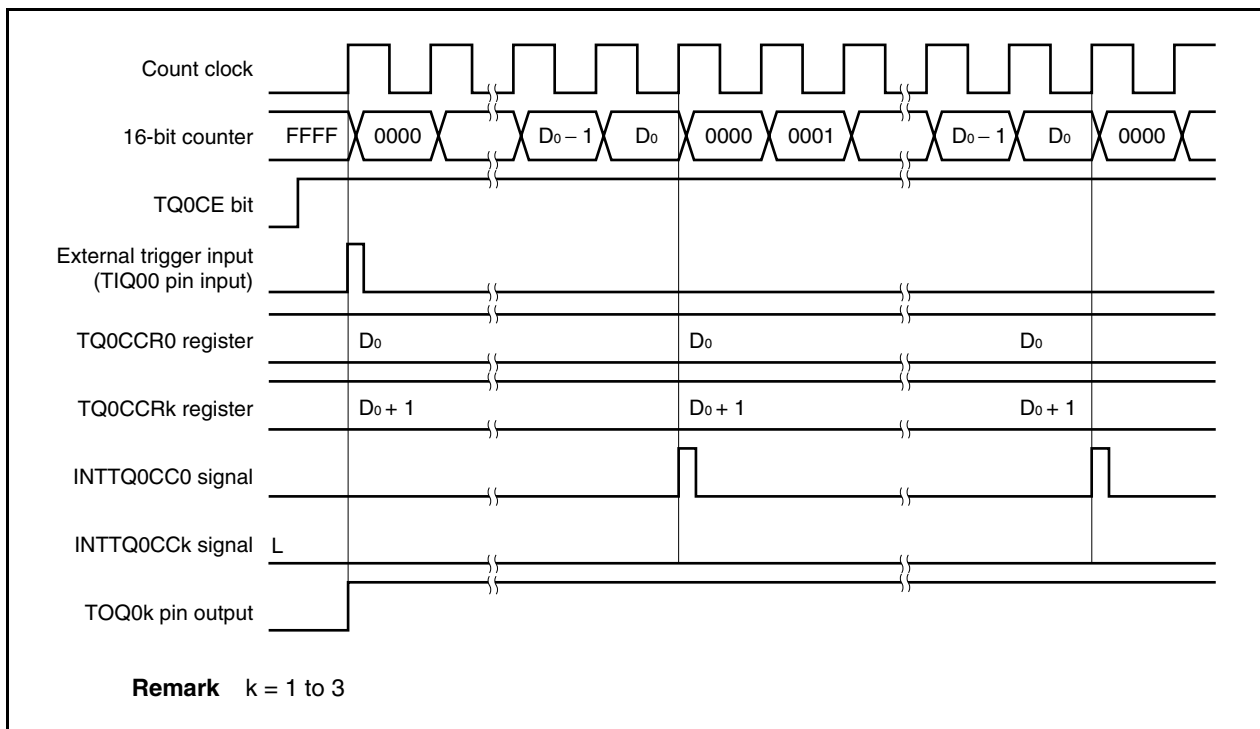

**(c) Conflict between trigger detection and match with CCRk buffer register**

If the trigger is detected immediately after the INTTQ0CCk signal is generated, the 16-bit counter is immediately cleared to 0000H, the output signal of the TOQ0k pin is asserted, and the counter continues counting. Consequently, the inactive period of the PWM waveform is shortened.

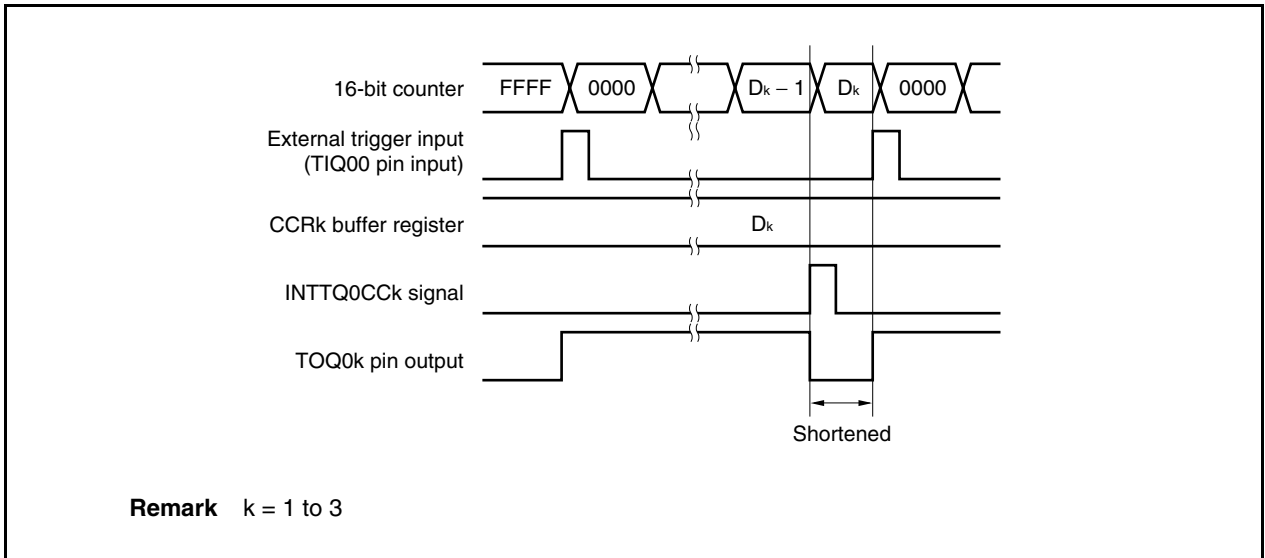

If the trigger is detected immediately before the INTTQ0CCk signal is generated, the INTTQ0CCk signal is not generated, and the 16-bit counter is cleared to 0000H and continues counting. The output signal of the TOQ0k pin remains active. Consequently, the active period of the PWM waveform is extended.

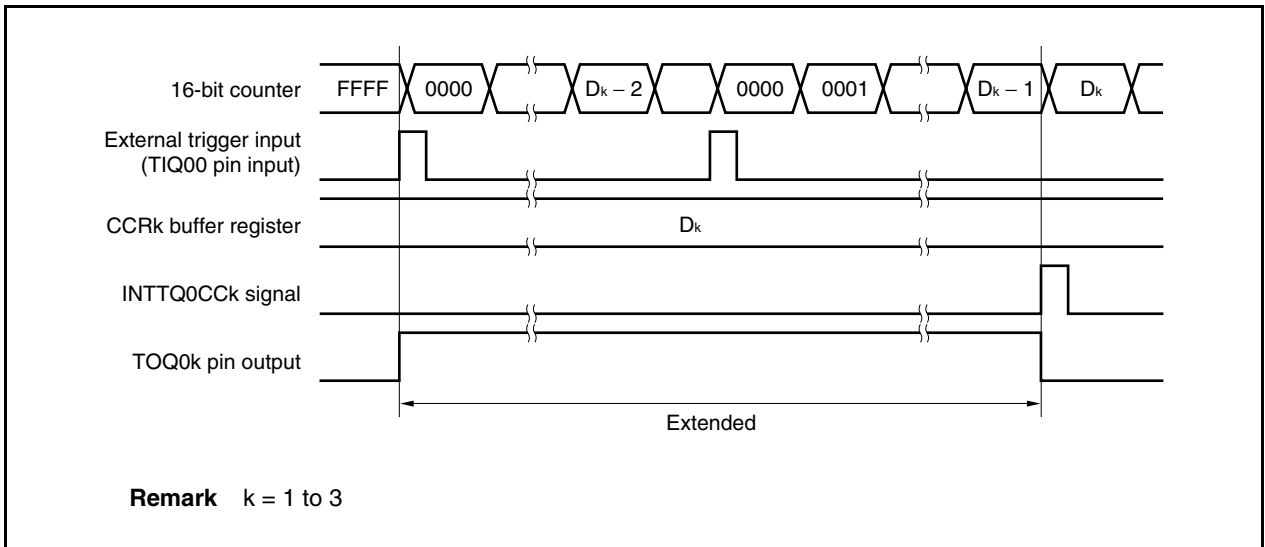

**(d) Conflict between trigger detection and match with CCR0 buffer register**

If the trigger is detected immediately after the INTTQ0CC0 signal is generated, the 16-bit counter is cleared to 0000H and continues counting up. Therefore, the active period of the TOQ0k pin is extended by time from generation of the INTTQ0CC0 signal to trigger detection.

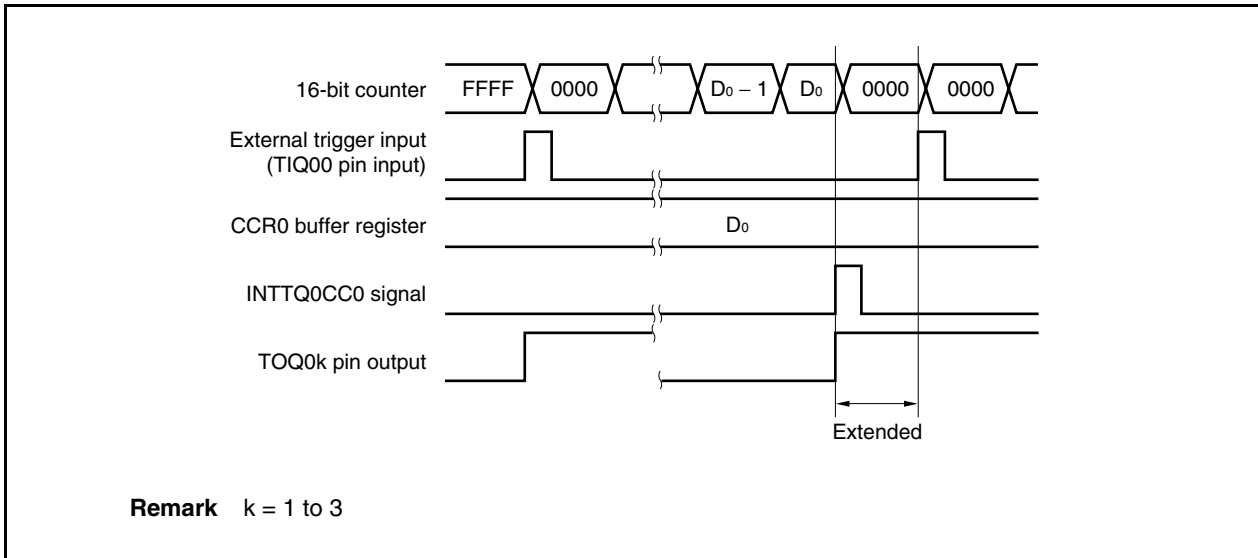

If the trigger is detected immediately before the INTTQ0CC0 signal is generated, the INTTQ0CC0 signal is not generated. The 16-bit counter is cleared to 0000H, the TOQ0k pin is asserted, and the counter continues counting. Consequently, the inactive period of the PWM waveform is shortened.

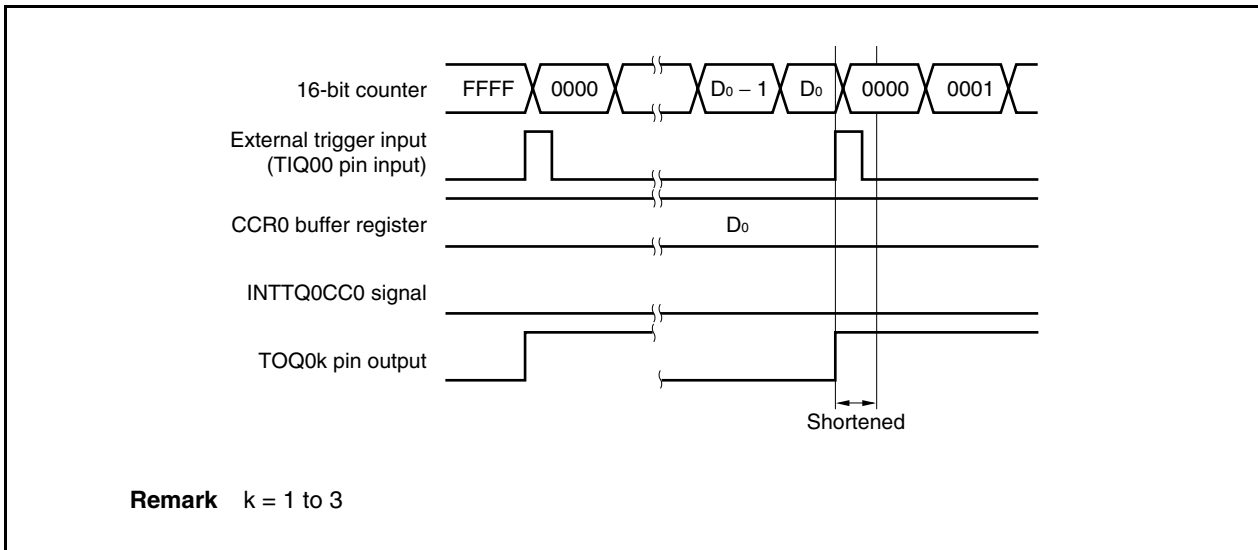

**(e) Generation timing of compare match interrupt request signal (INTTQ0CCK)**

The timing of generation of the INTTQ0CCK signal in the external trigger pulse output mode differs from the timing of other mode INTTQ0CCK signals; the INTTQ0CCK signal is generated when the count value of the 16-bit counter matches the value of the CCRk buffer register.

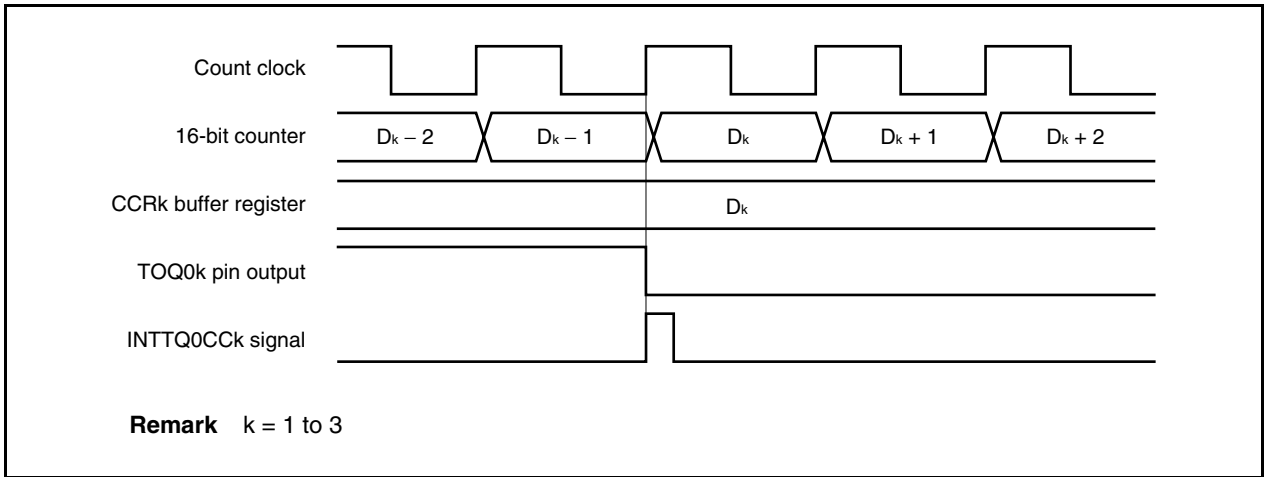

Usually, the INTTQ0CCK signal is generated in synchronization with the next count up after the count value of the 16-bit counter matches the value of the CCRk buffer register.

In the external trigger pulse output mode, however, it is generated one clock earlier. This is because the timing is changed to match the timing of changing the output signal of the TOQ0k pin.

### 8.6.4 One-shot pulse output mode (TQ0MD2 to TQ0MD0 bits = 011)

In the one-shot pulse output mode, 16-bit timer/event counter Q waits for a trigger when the TQ0CTL0.TQ0CE bit is set to 1. When the valid edge of an external trigger input (TIQ00) is detected, 16-bit timer/event counter Q starts counting, and outputs a one-shot pulse from the TOQ01 to TOQ03 pins.

Instead of the external trigger input (TIQ00), a software trigger can also be generated to output the pulse. When the software trigger is used, the TOQ00 pin outputs the active level while the 16-bit counter is counting, and the inactive level when the counter is stopped (waiting for a trigger).

Figure 8-24. Configuration in One-Shot Pulse Output Mode

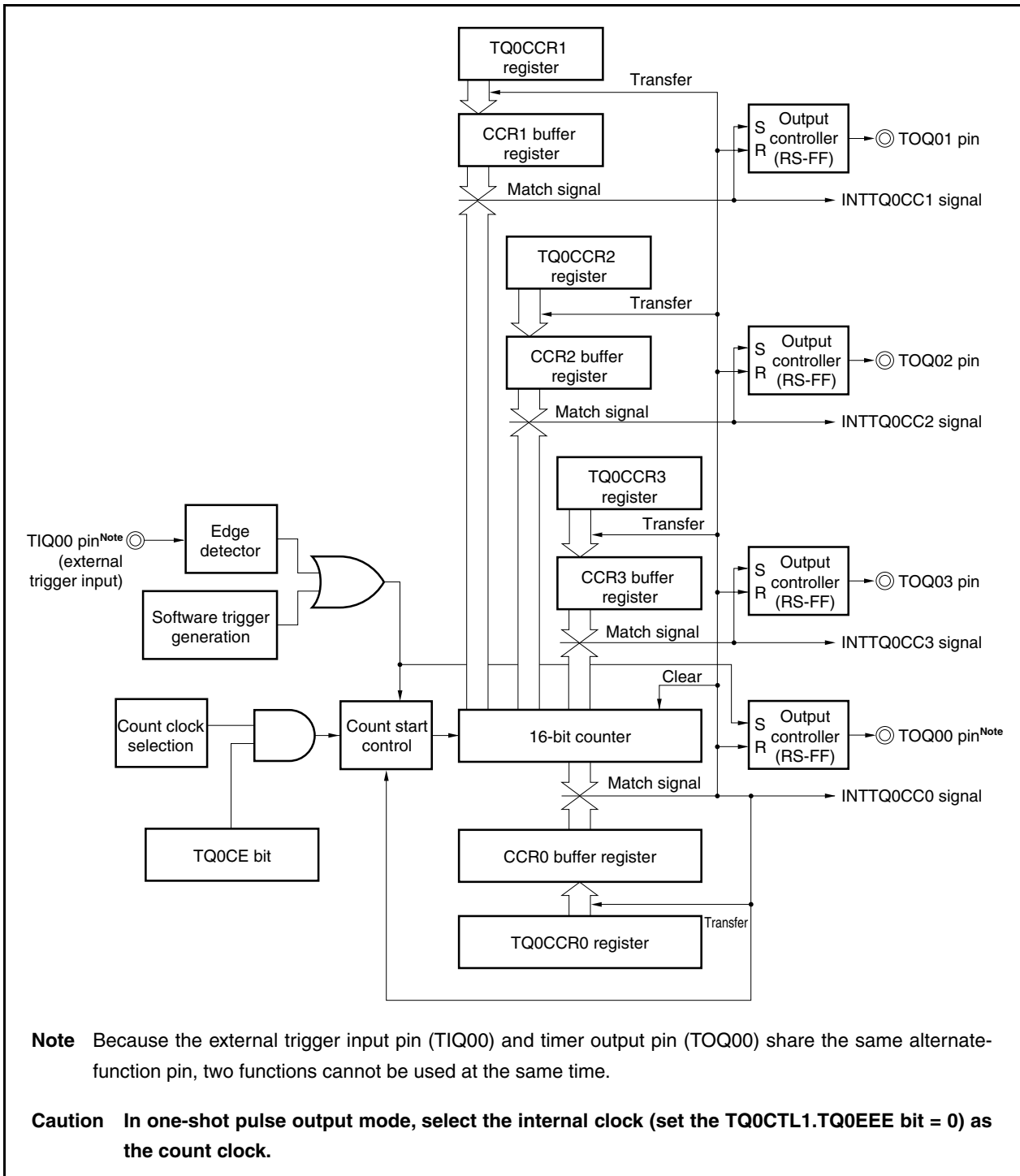
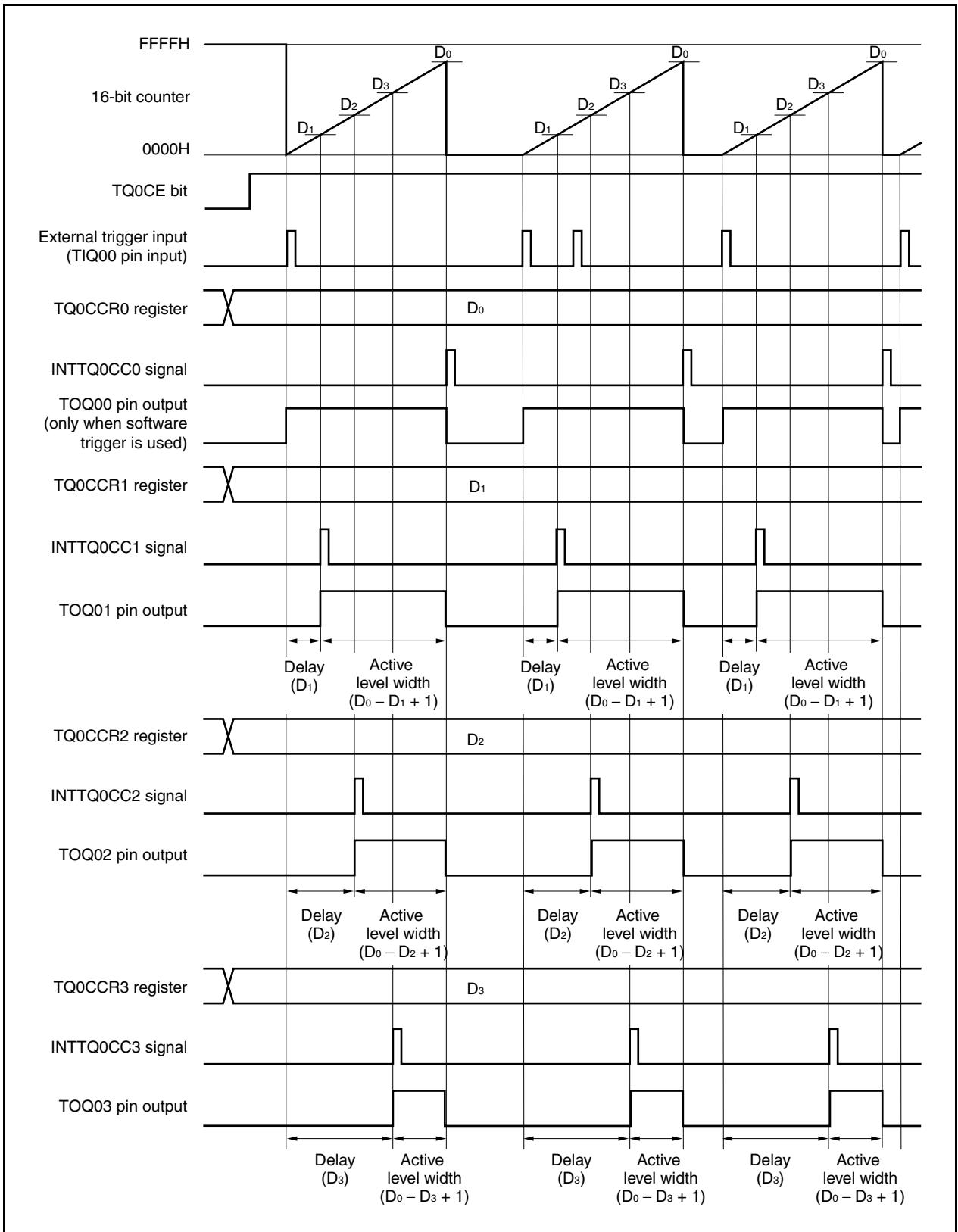

Figure 8-25. Basic Timing in One-Shot Pulse Output Mode



When the TQ0CE bit is set to 1, 16-bit timer/event counter Q waits for a trigger. When the trigger is generated, the 16-bit counter is cleared from FFFFH to 0000H, starts counting, and outputs a one-shot pulse from the TOQ0k pin. After the one-shot pulse is output, the 16-bit counter is set to 0000H, stops counting, and waits for a trigger. When the trigger is generated again, the 16-bit counter starts counting from 0000H. Generation of a trigger is ignored while the one-shot pulse is being output.

The output delay period and active level width of the one-shot pulse can be calculated as follows.

$$\text{Output delay period} = (\text{Set value of TQ0CCRk register}) \times \text{Count clock cycle}$$

$$\text{Active level width} = (\text{Set value of TQ0CCR0 register} - \text{Set value of TQ0CCRk register} + 1) \times \text{Count clock cycle}$$

The compare match interrupt request signal INTTQ0CC0 is generated when the 16-bit counter counts after its count value matches the value of the CCR0 buffer register. The compare match interrupt request signal INTTQ0CCk is generated when the count value of the 16-bit counter matches the value of the CCRk buffer register.

The valid edge of an external trigger input (TIQ00 pin) or setting the software trigger (TQ0CTL1.TQ0EST bit) to 1 is used as the trigger.

**Remark** k = 1 to 3

**Figure 8-26. Setting of Registers in One-Shot Pulse Output Mode (1/3)**

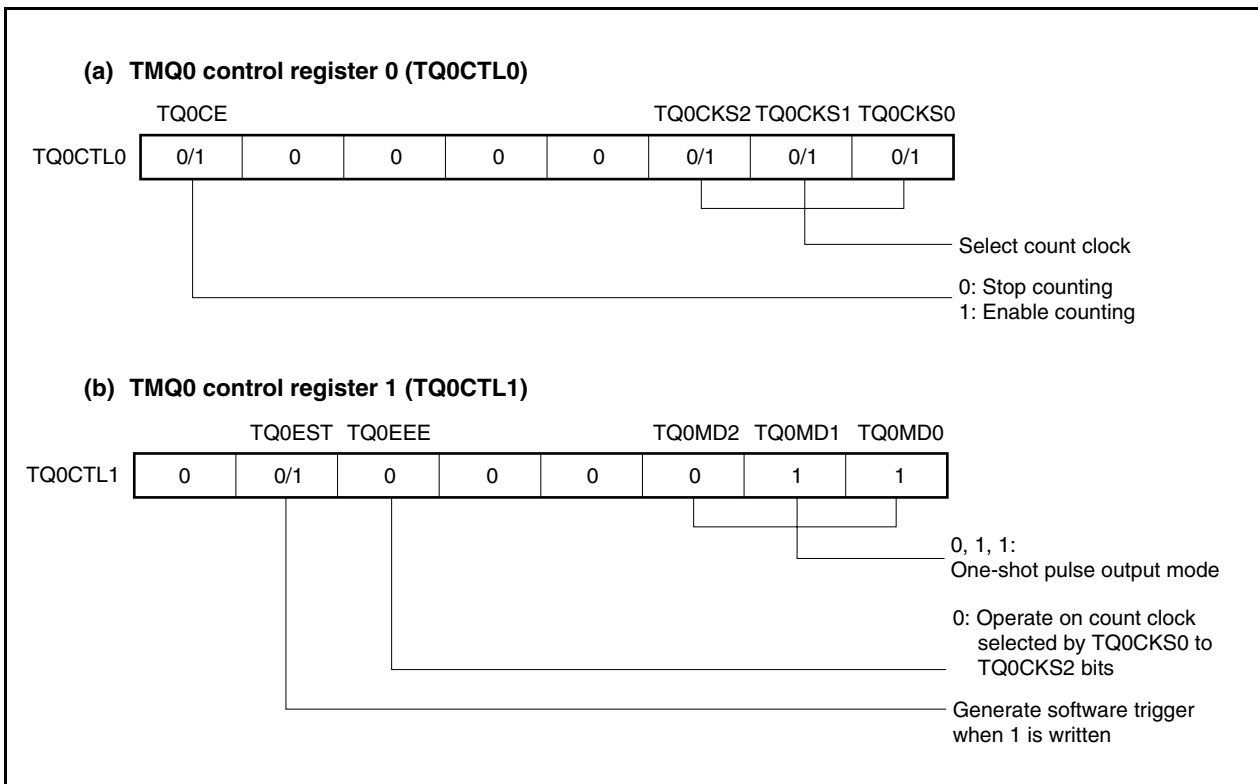



Figure 8-26. Register Setting in One-Shot Pulse Output Mode (2/3)

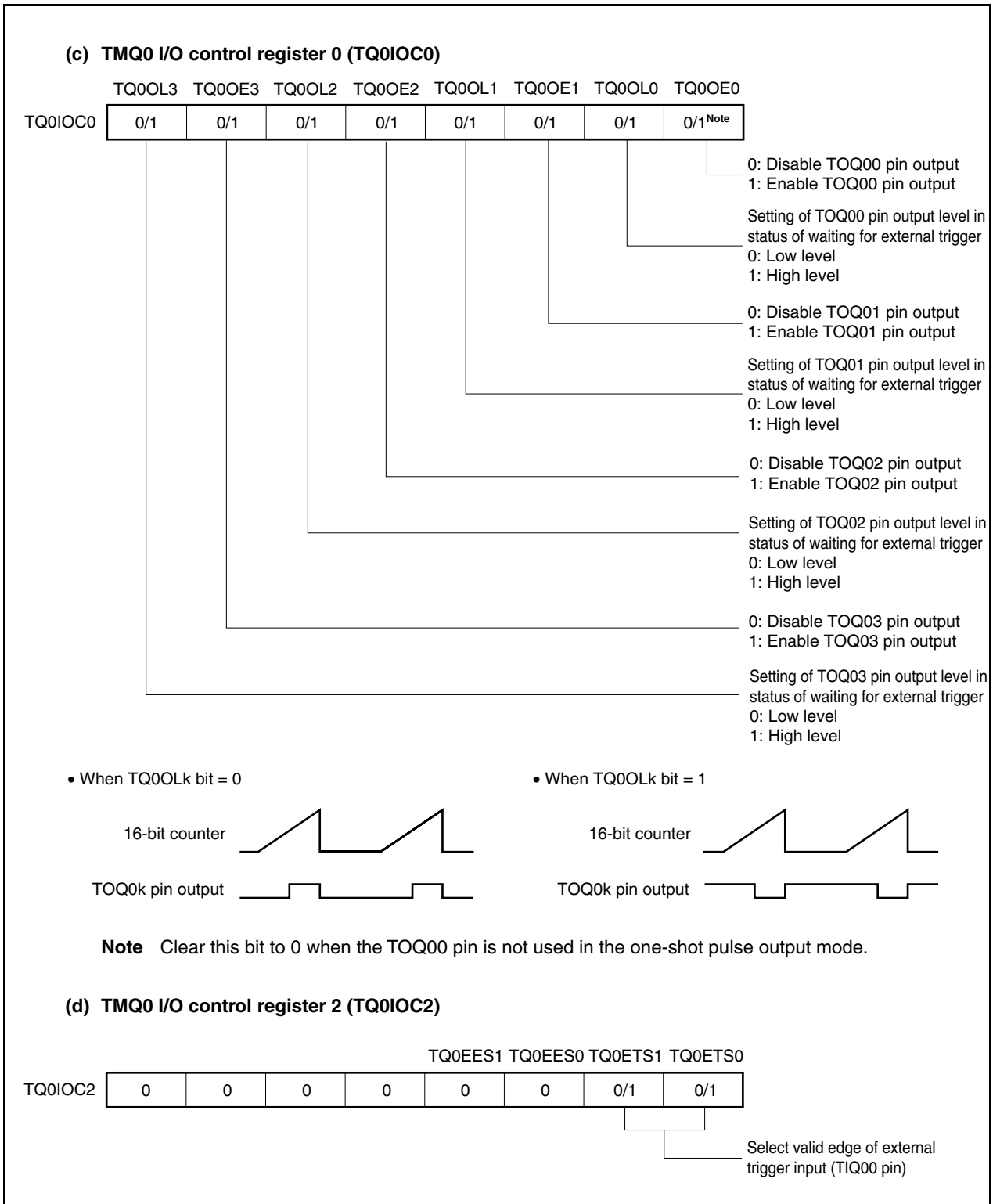

Figure 8-26. Register Setting in One-Shot Pulse Output Mode (3/3)

**(e) TMQ0 counter read buffer register (TQ0CNT)**

The value of the 16-bit counter can be read by reading the TQ0CNT register.

**(f) TMQ0 capture/compare registers 0 to 3 (TQ0CCR0 to TQ0CCR3)**

If  $D_0$  is set to the TQ0CCR0 register and  $D_k$  to the TQ0CCRk register, the active level width and output delay period of the one-shot pulse are as follows.

Active level width =  $(D_0 - D_k + 1) \times$  Count clock cycle

Output delay period =  $(D_k) \times$  Count clock cycle

**Caution** One-shot pulses are not output even in the one-shot pulse output mode, if the value set in the TQ0CCR0 register is greater than that set in the TQ0CCRk register.

**Remarks** 1. TMQ0 I/O control register 1 (TQ0IOC1) and TMQ0 option register 0 (TQ0OPT0) are not used in the one-shot pulse output mode.

2.  $k = 1$  to 3

(1) Operation flow in one-shot pulse output mode

Figure 8-27. Software Processing Flow in One-Shot Pulse Output Mode (1/2)

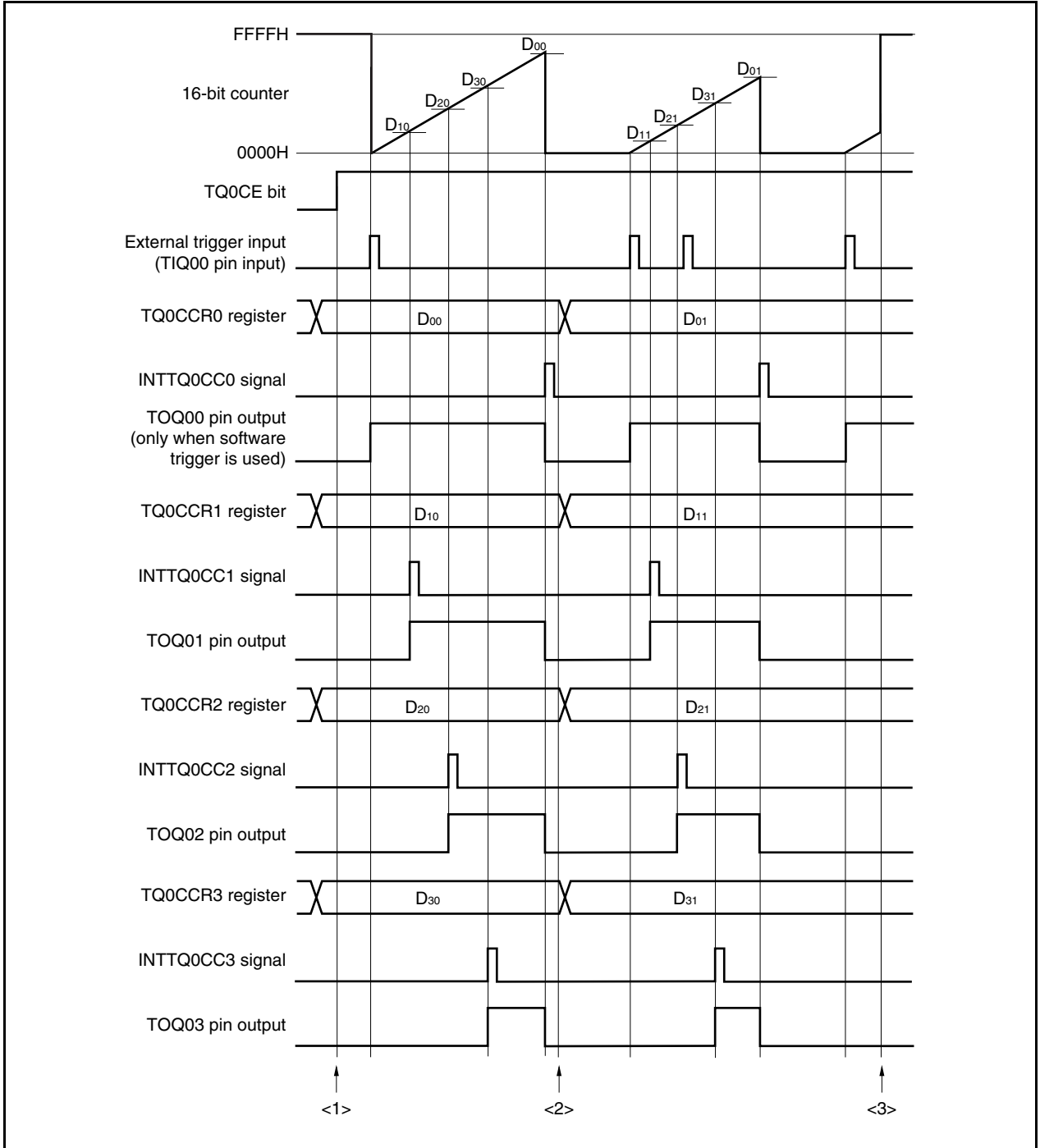
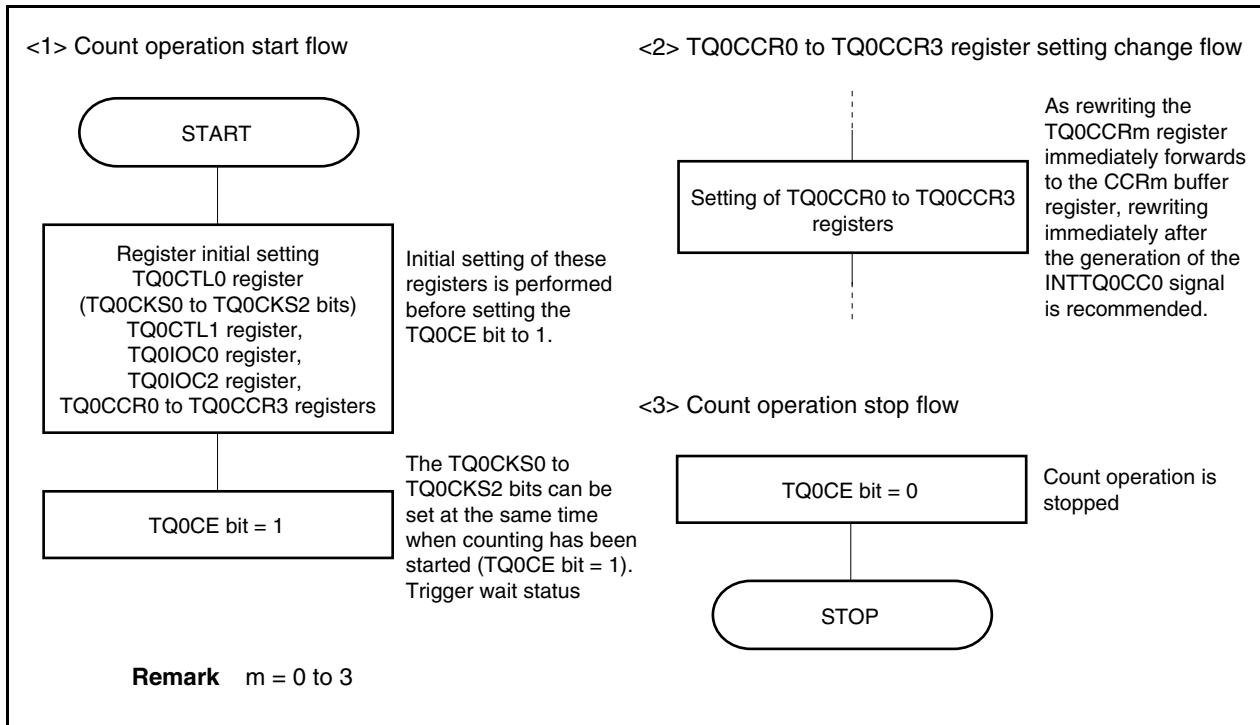

Figure 8-27. Software Processing Flow in One-Shot Pulse Output Mode (2/2)



## (2) Operation timing in one-shot pulse output mode

## (a) Note on rewriting TQ0CCRm register

If the value of the TQ0CCR0 register is rewritten to a smaller value during counting, the 16-bit counter may overflow. If there is a possibility of overflow, stop counting and then change the set value.

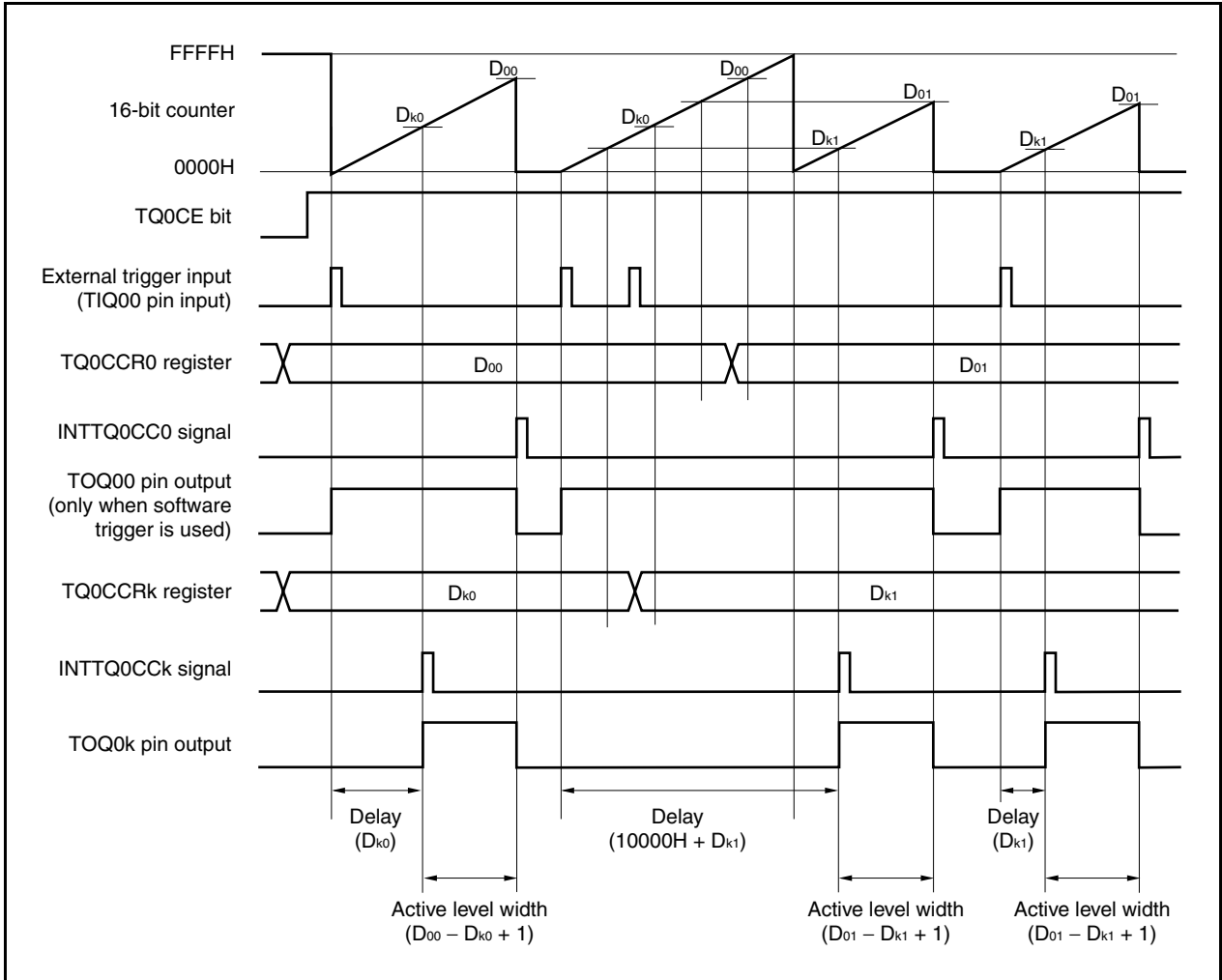

When the TQ0CCR0 register is rewritten from D<sub>00</sub> to D<sub>01</sub> and the TQ0CCRk register from D<sub>k0</sub> to D<sub>k1</sub> where D<sub>00</sub> > D<sub>01</sub> and D<sub>k0</sub> > D<sub>k1</sub>, if the TQ0CCRk register is rewritten when the count value of the 16-bit counter is greater than D<sub>k1</sub> and less than D<sub>k0</sub> and if the TQ0CCR0 register is rewritten when the count value is greater than D<sub>01</sub> and less than D<sub>00</sub>, each set value is reflected as soon as the register has been rewritten and compared with the count value. The counter counts up to FFFFH and then counts up again from 0000H. When the count value matches D<sub>k1</sub>, the counter generates the INTTQ0CCk signal and asserts the TOQ0k pin. When the count value matches D<sub>01</sub>, the counter generates the INTTQ0CC0 signal, deasserts the TOQ0k pin, and stops counting.

Therefore, the counter may output a pulse with a delay period or active period different from that of the one-shot pulse that is originally expected.

**Remark** m = 0 to 3,  
k = 1 to 3

**(b) Generation timing of compare match interrupt request signal (INTTQ0CCK)**

The generation timing of the INTTQ0CCK signal in the one-shot pulse output mode is different from other mode INTTQ0CCK signals; the INTTQ0CCK signal is generated when the count value of the 16-bit counter matches the value of the TQ0CCRk register.

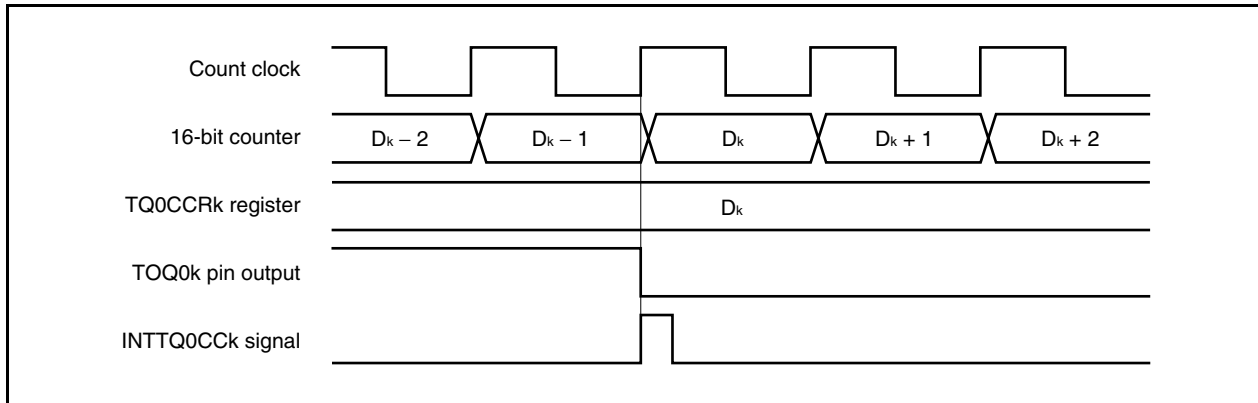

Usually, the INTTQ0CCK signal is generated when the 16-bit counter counts up next time after its count value matches the value of the TQ0CCRk register.

In the one-shot pulse output mode, however, it is generated one clock earlier. This is because the timing is changed to match the change timing of the TOQ0k pin.

**Remark**  $k = 1$  to 3

**8.6.5 PWM output mode (TQ0MD2 to TQ0MD0 bits = 100)**

In the PWM output mode, a PWM waveform is output from the TOQ01 to TOQ03 pins when the TQ0CTL0.TQ0CE bit is set to 1.

In addition, a square wave with a duty factor of 50% with the set value of the TQ0CCR0 register + 1 as half its cycle is output from the TOQ00 pin.

**Figure 8-28. Configuration in PWM Output Mode**

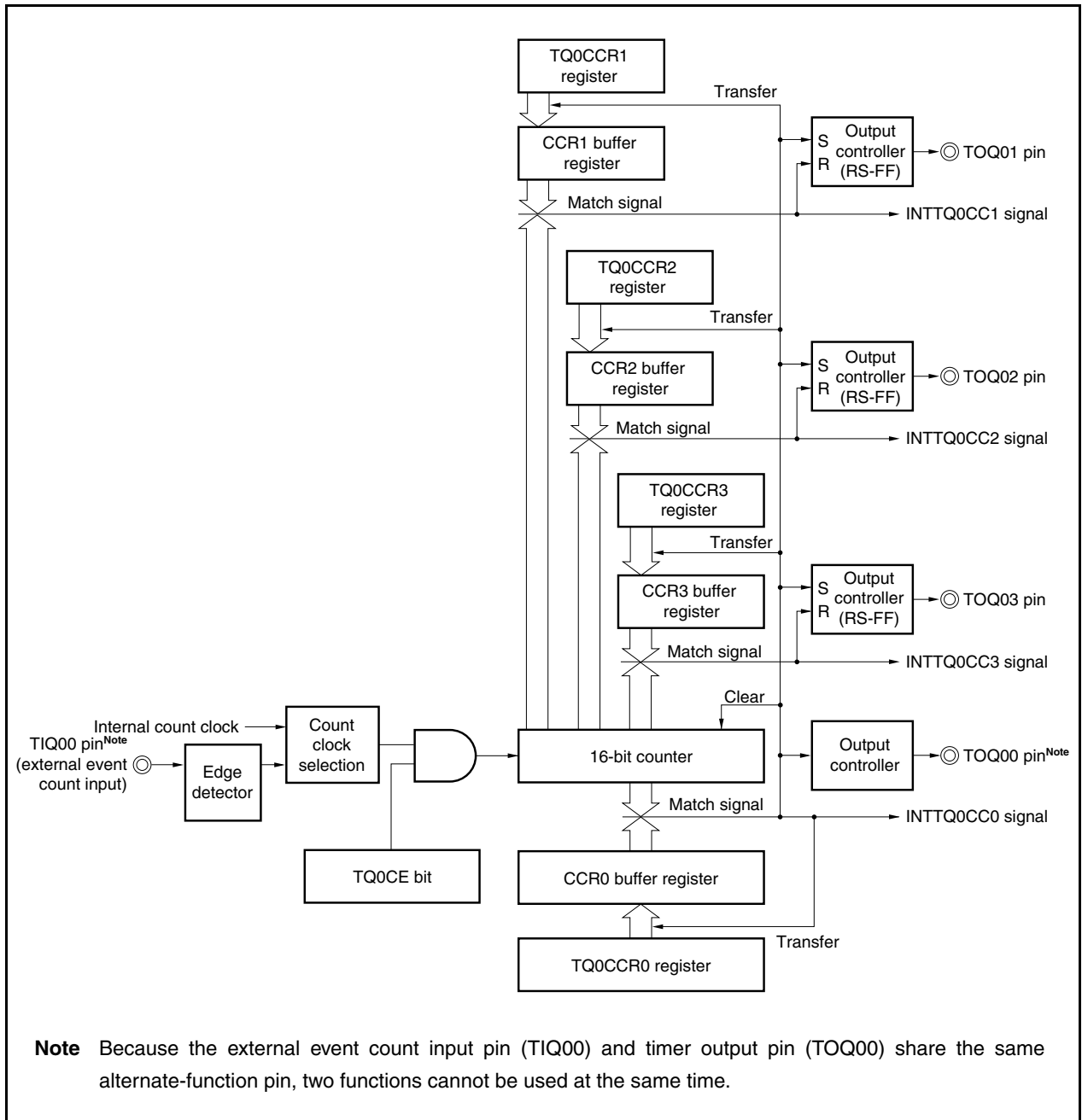

**Note** Because the external event count input pin (TIQ00) and timer output pin (TOQ00) share the same alternate-function pin, two functions cannot be used at the same time.

Figure 8-29. Basic Timing in PWM Output Mode

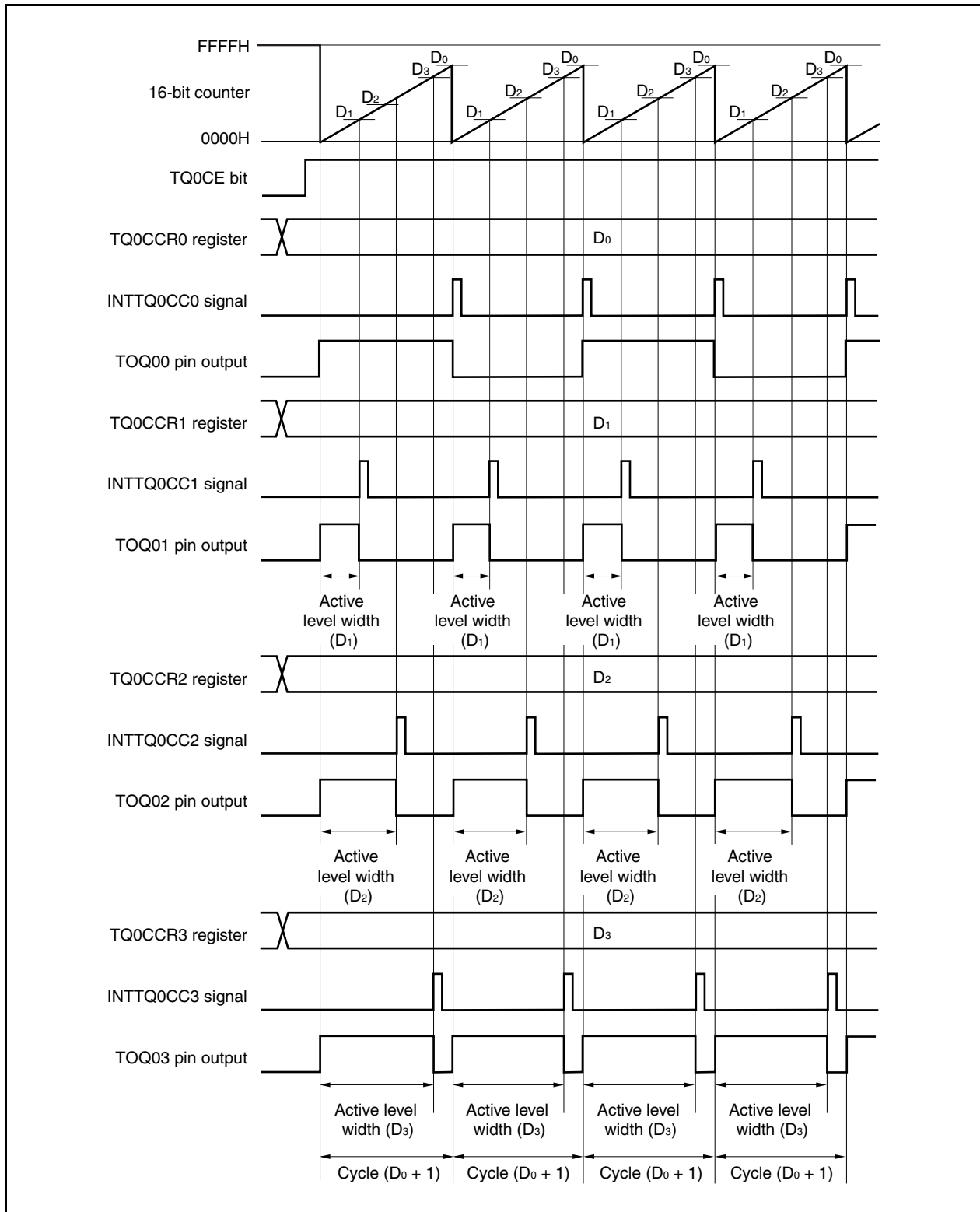



When the TQ0CE bit is set to 1, the 16-bit counter is cleared from FFFFH to 0000H, starts counting, and outputs PWM waveform from the TOQ0k pin.

The active level width, cycle, and duty factor of the PWM waveform can be calculated as follows.

$$\text{Active level width} = (\text{Set value of TQ0CCRk register}) \times \text{Count clock cycle}$$

$$\text{Cycle} = (\text{Set value of TQ0CCR0 register} + 1) \times \text{Count clock cycle}$$

$$\text{Duty factor} = (\text{Set value of TQ0CCRk register}) / (\text{Set value of TQ0CCR0 register} + 1)$$

The PWM waveform can be changed by rewriting the TQ0CCRm register while the counter is operating. The newly written value is reflected when the count value of the 16-bit counter matches the value of the CCR0 buffer register and the 16-bit counter is cleared to 0000H.

The compare match interrupt request signal INTTQ0CC0 is generated when the 16-bit counter counts next time after its count value matches the value of the CCR0 buffer register, and the 16-bit counter is cleared to 0000H. The compare match interrupt request signal INTTQ0CCk is generated when the count value of the 16-bit counter matches the value of the CCRk buffer register.

**Remark** k = 1 to 3, m = 0 to 3

Figure 8-30. Setting of Registers in PWM Output Mode (1/3)

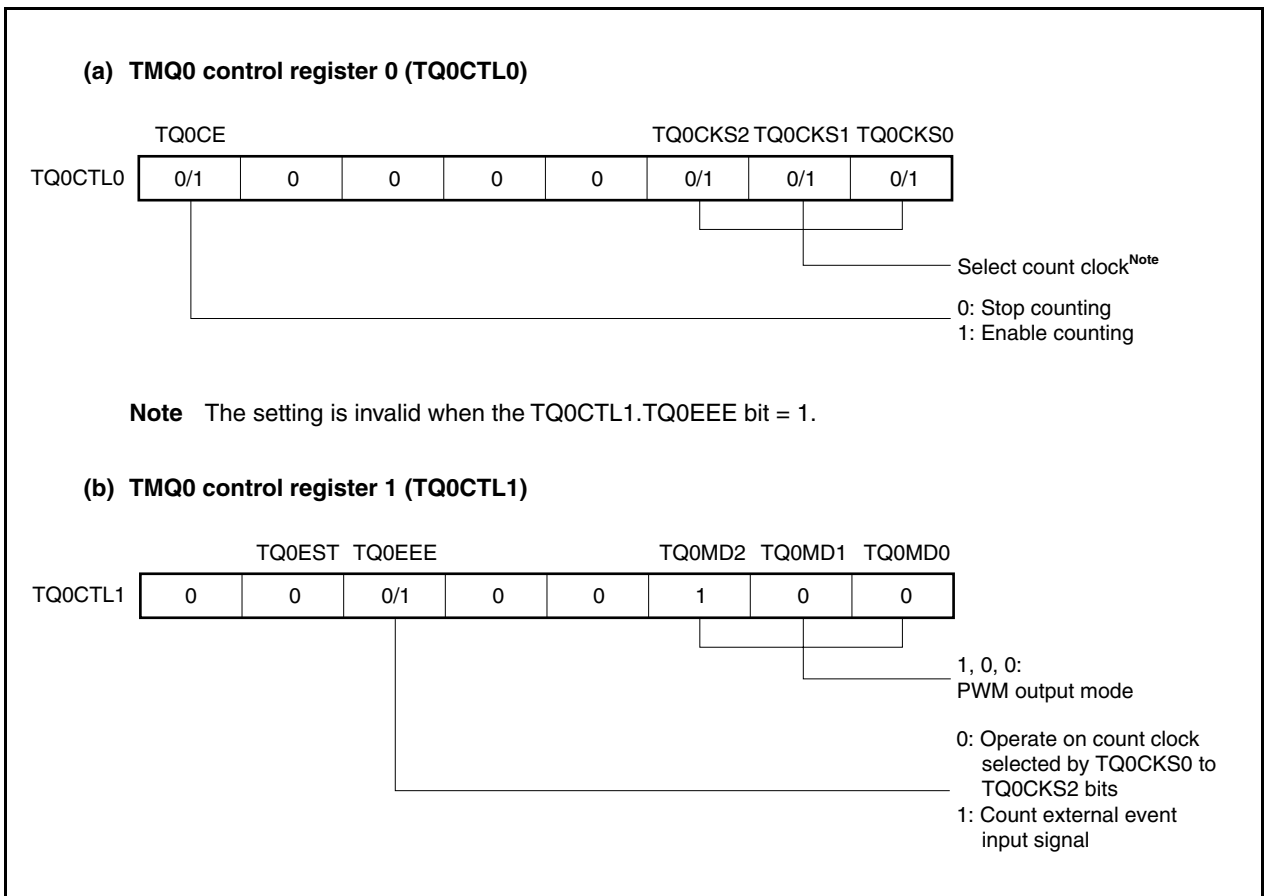

Figure 8-30. Setting of Registers in PWM Output Mode (2/3)

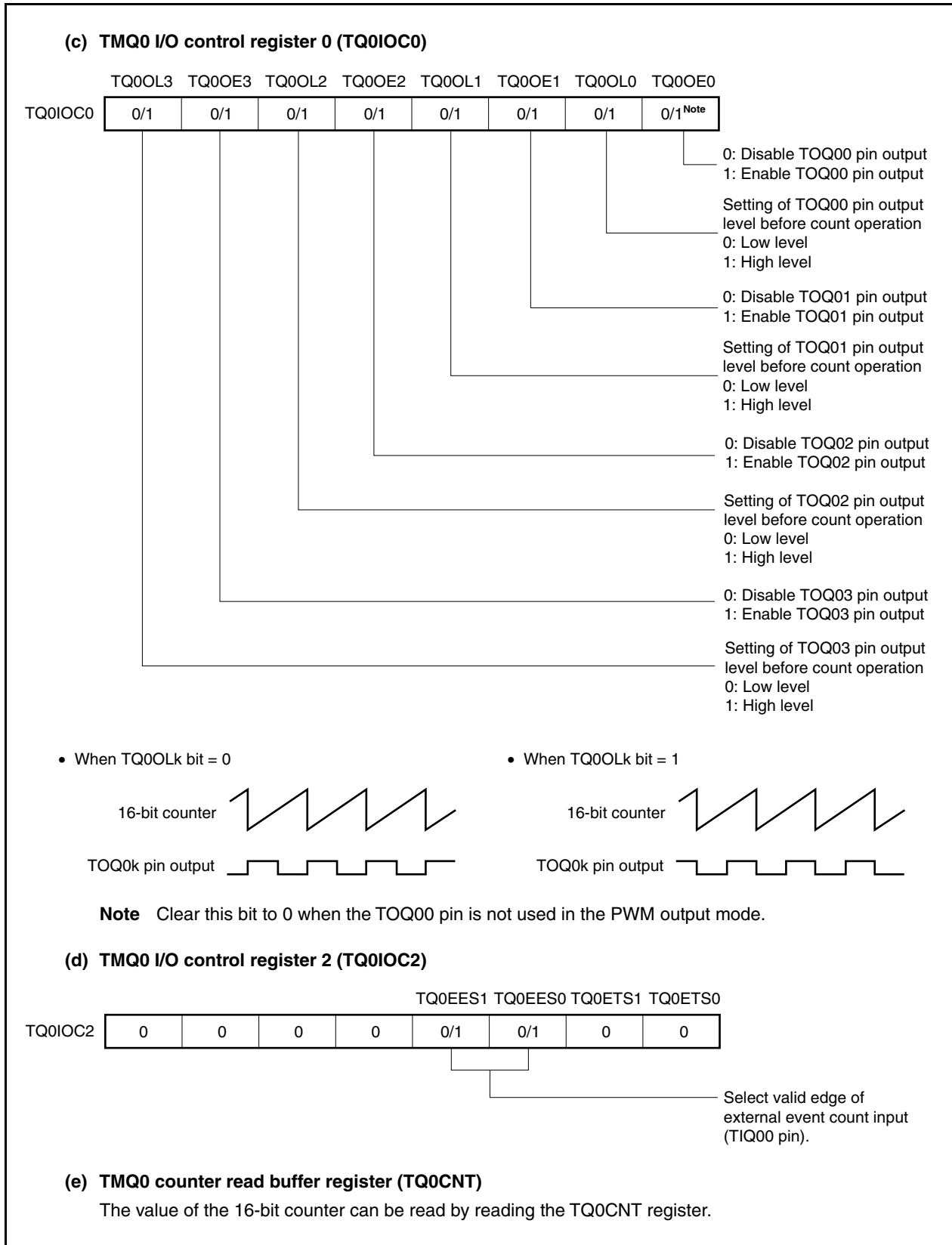

Figure 8-30. Register Setting in PWM Output Mode (3/3)

**(f) TMQ0 capture/compare registers 0 to 3 (TQ0CCR0 to TQ0CCR3)**

If  $D_0$  is set to the TQ0CCR0 register and  $D_k$  to the TQ0CCR1 register, the cycle and active level of the PWM waveform are as follows.

$$\text{Cycle} = (D_0 + 1) \times \text{Count clock cycle}$$

$$\text{Active level width} = D_k \times \text{Count clock cycle}$$

- Remarks**
1. TMQ0 I/O control register 1 (TQ0IOC1) and TMQ0 option register 0 (TQ0OPT0) are not used in the PWM output mode.
  2. Updating the TMQ0 capture/compare register 2 (TQ0CCR2) and TMQ0 capture/compare register 3 (TQ0CCR3) is validated by writing the TMQ0 capture/compare register 1 (TQ0CCR1).

(1) Operation flow in PWM output mode

Figure 8-31. Software Processing Flow in PWM Output Mode (1/2)

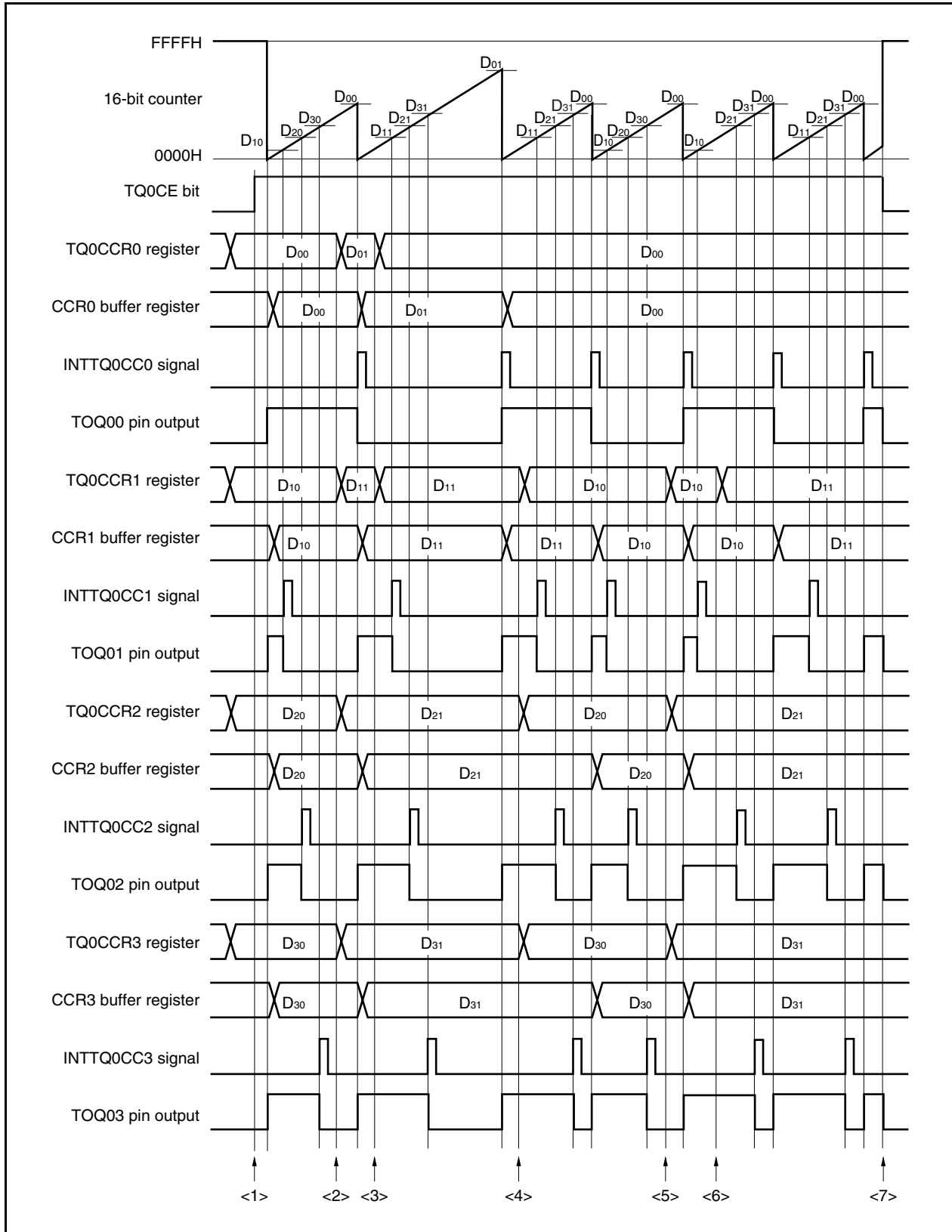
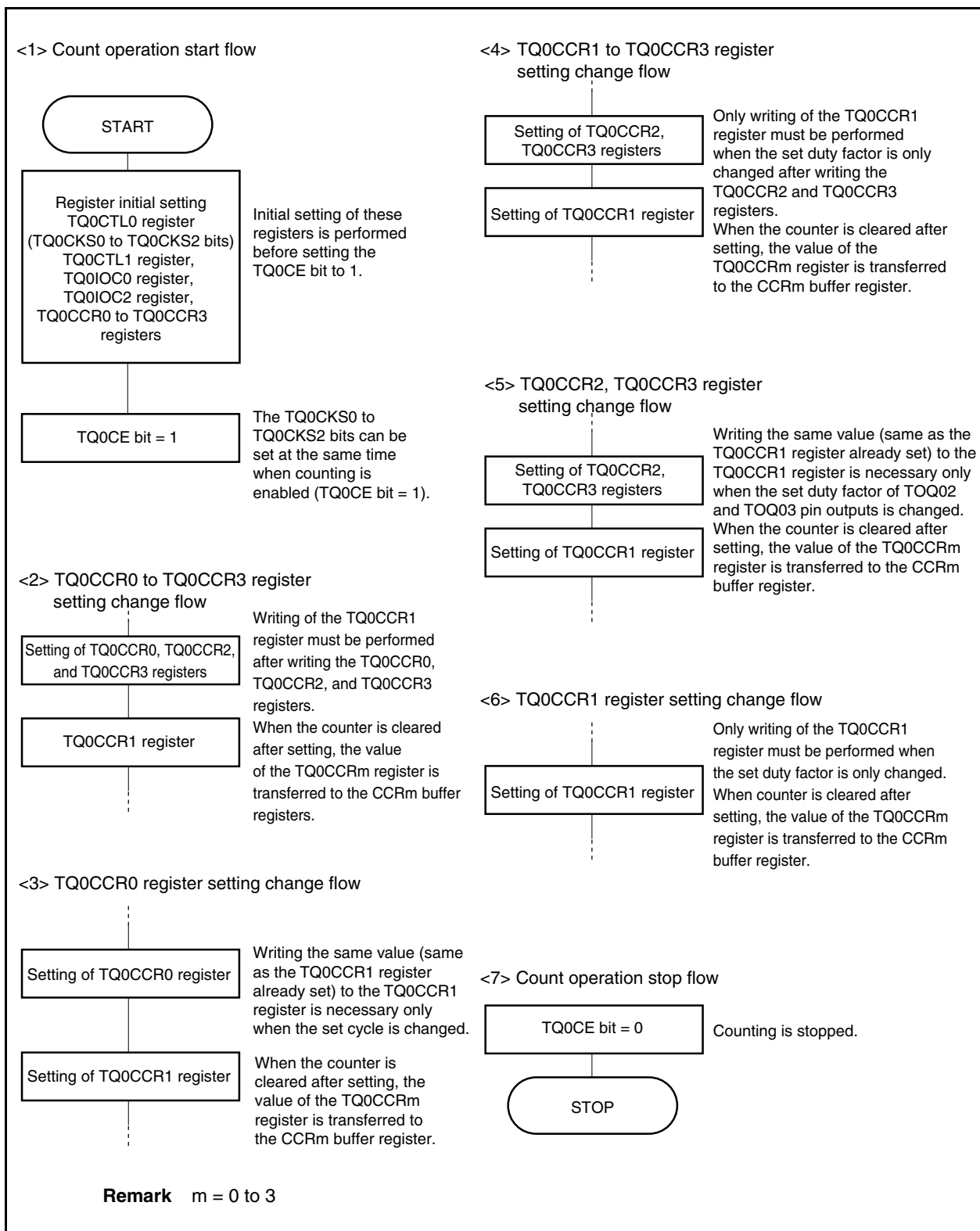

Figure 8-31. Software Processing Flow in PWM Output Mode (2/2)



(2) PWM output mode operation timing

(a) Changing pulse width during operation

To change the PWM waveform while the counter is operating, write the TQ0CCR1 register last. Rewrite the TQ0CCRm register after writing the TQ0CCR1 register after the INTTQ0CC0 signal is detected.

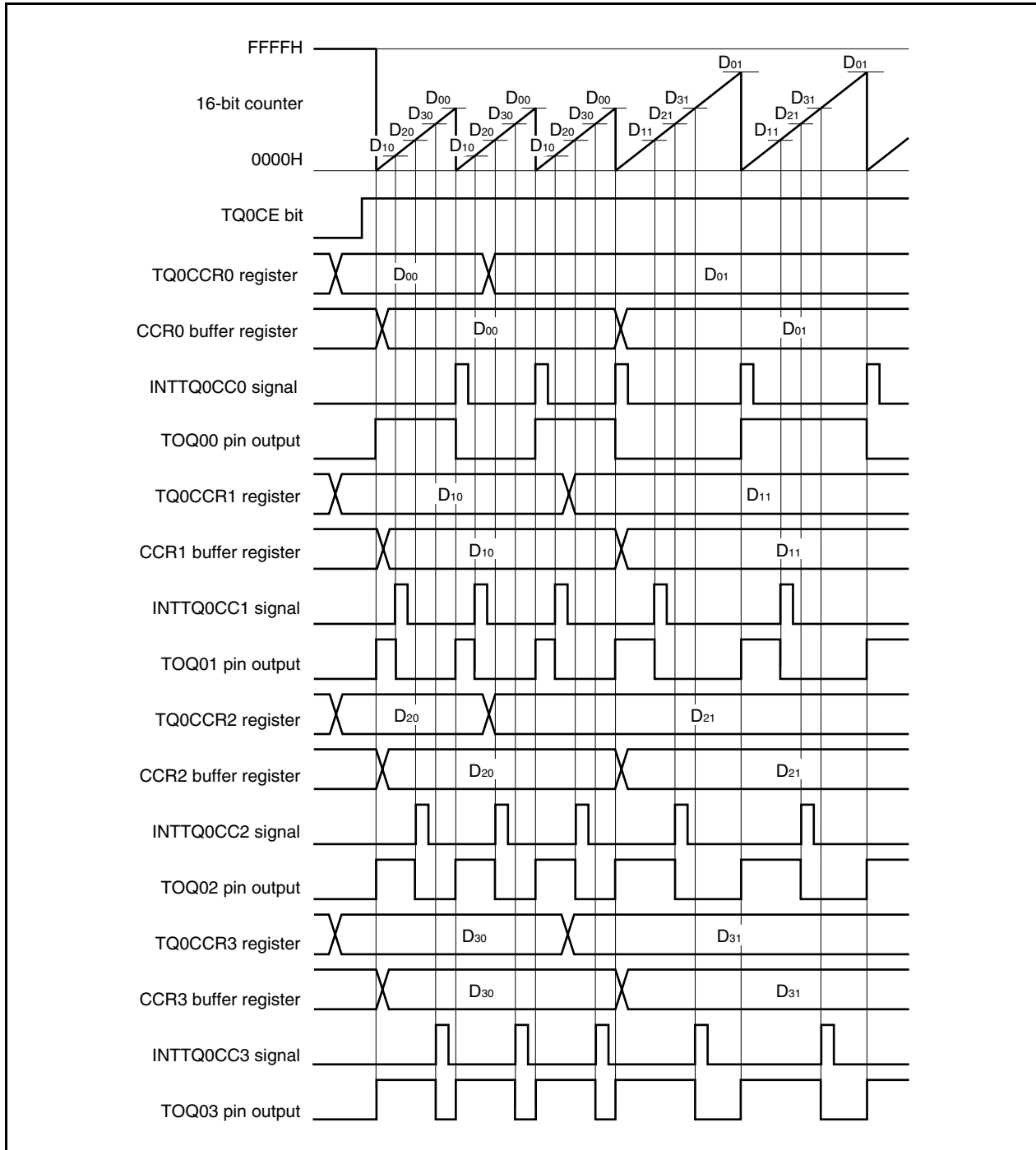

To transfer data from the TQ0CCRm register to the CCRm buffer register, the TQ0CCR1 register must be written.

To change both the cycle and active level of the PWM waveform at this time, first set the cycle to the TQ0CCR0 register, set the active level width to the TQ0CCR2 and TQ0CCR3 registers, and then set an active level width to the TQ0CCR1 register.

To change only the cycle of the PWM waveform, first set the cycle to the TQ0CCR0 register, and then write the same value (same as the TQ0CCR1 register already set) to the TQ0CCR1 register.

To change only the active level width (duty factor) of PWM wave, first set the active level to the TQ0CCR2 and TQ0CCR3 registers, and then set an active level to the TQ0CCR1 register.

To change only the active level width (duty factor) of the PWM waveform output by the TOQ01 pin, only the TQ0CCR1 register has to be set.

To change only the active level width (duty factor) of the PWM waveform output by the TOQ02 and TOQ03 pins, first set an active level width to the TQ0CCR2 and TQ0CCR3 registers, and then write the same value (same as the TQ0CCR1 register already set) to the TQ0CCR1 register.

After the TQ0CCR1 register is written, the value written to the TQ0CCRm register is transferred to the CCRm buffer register in synchronization with the timing of clearing the 16-bit counter, and is used as a value to be compared with the value of the 16-bit counter.

To change only the cycle of the PWM waveform, first set a cycle to the TQ0CCR0 register, and then write the same value to the TQ0CCR1 register.

To write the TQ0CCR0 to TQ0CCR3 registers again after writing the TQ0CCR1 register once, do so after the INTTQ0CC0 signal is generated. Otherwise, the value of the CCRm buffer register may become undefined because the timing of transferring data from the TQ0CCRm register to the CCRm buffer register conflicts with writing the TQ0CCRm register.

**Remark** m = 0 to 3

**(b) 0%/100% output of PWM waveform**

To output a 0% waveform, set the TQ0CCRk register to 0000H. The 16-bit counter is cleared to 0000H and the INTTQ0CC0 and INTTQ0CCk signals are generated at the timing following the clock in which the count value of the 16-bit counter matches the value of the CCR0 buffer register.

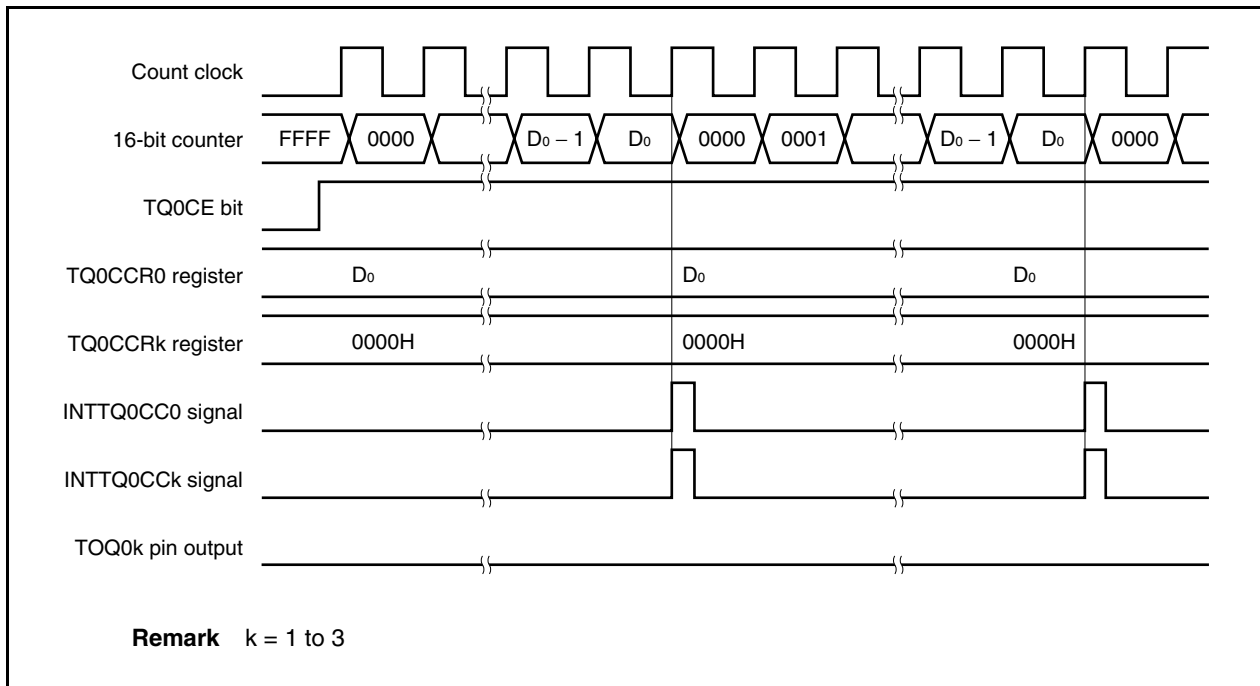

To output a 100% waveform, set a value of (set value of TQ0CCR0 register + 1) to the TQ0CCRk register. If the set value of the TQ0CCR0 register is FFFFH, 100% output cannot be produced.

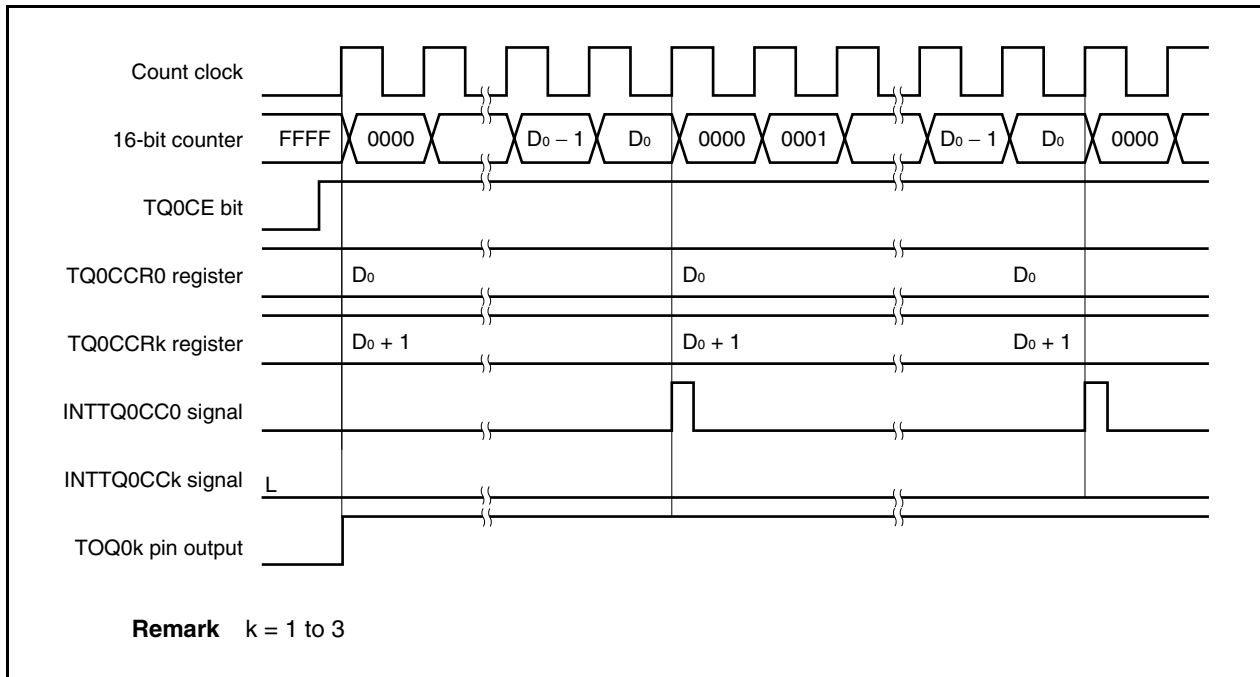



**(c) Generation timing of compare match interrupt request signal (INTTQ0CCK)**

The timing of generation of the INTTQ0CCK signal in the PWM output mode differs from the timing of other mode INTTQ0CCK signals; the INTTQ0CCK signal is generated when the count value of the 16-bit counter matches the value of the TQ0CCRk register.

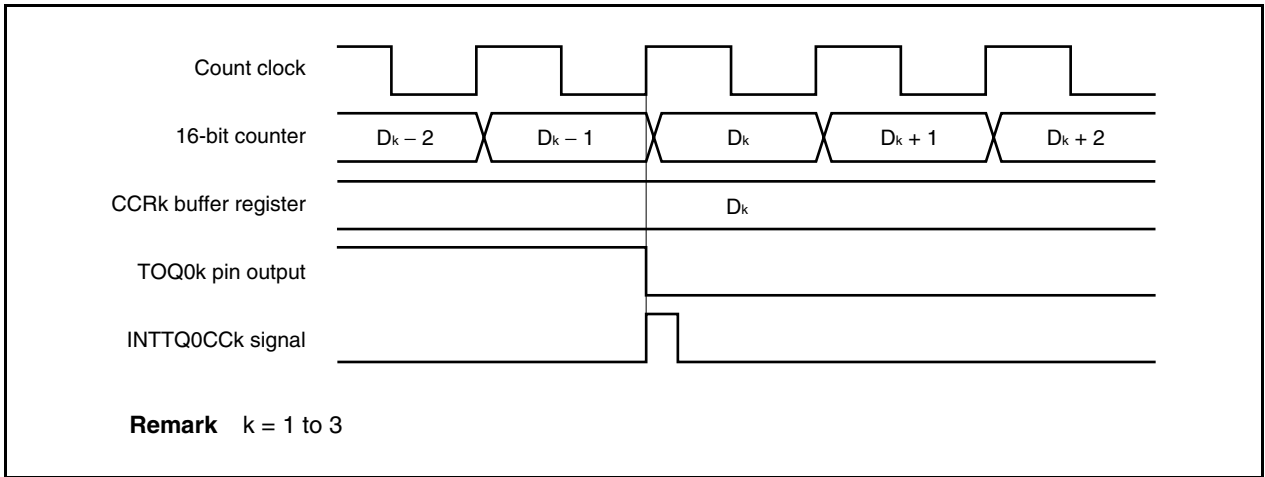

Usually, the INTTQ0CCK signal is generated in synchronization with the next counting up after the count value of the 16-bit counter matches the value of the TQ0CCRk register.

In the PWM output mode, however, it is generated one clock earlier. This is because the timing is changed to match the change timing of the output signal of the TOQ0k pin.

**8.6.6 Free-running timer mode (TQ0MD2 to TQ0MD0 bits = 101)**

In the free-running timer mode, 16-bit timer/event counter Q starts counting when the TQ0CTL0.TQ0CE bit is set to 1. At this time, the TQ0CCRm register can be used as a compare register or a capture register, depending on the setting of the TQ0OPT0.TQ0CCSm bits.

**Remark** m = 0 to 3

Figure 8-32. Configuration in Free-Running Timer Mode

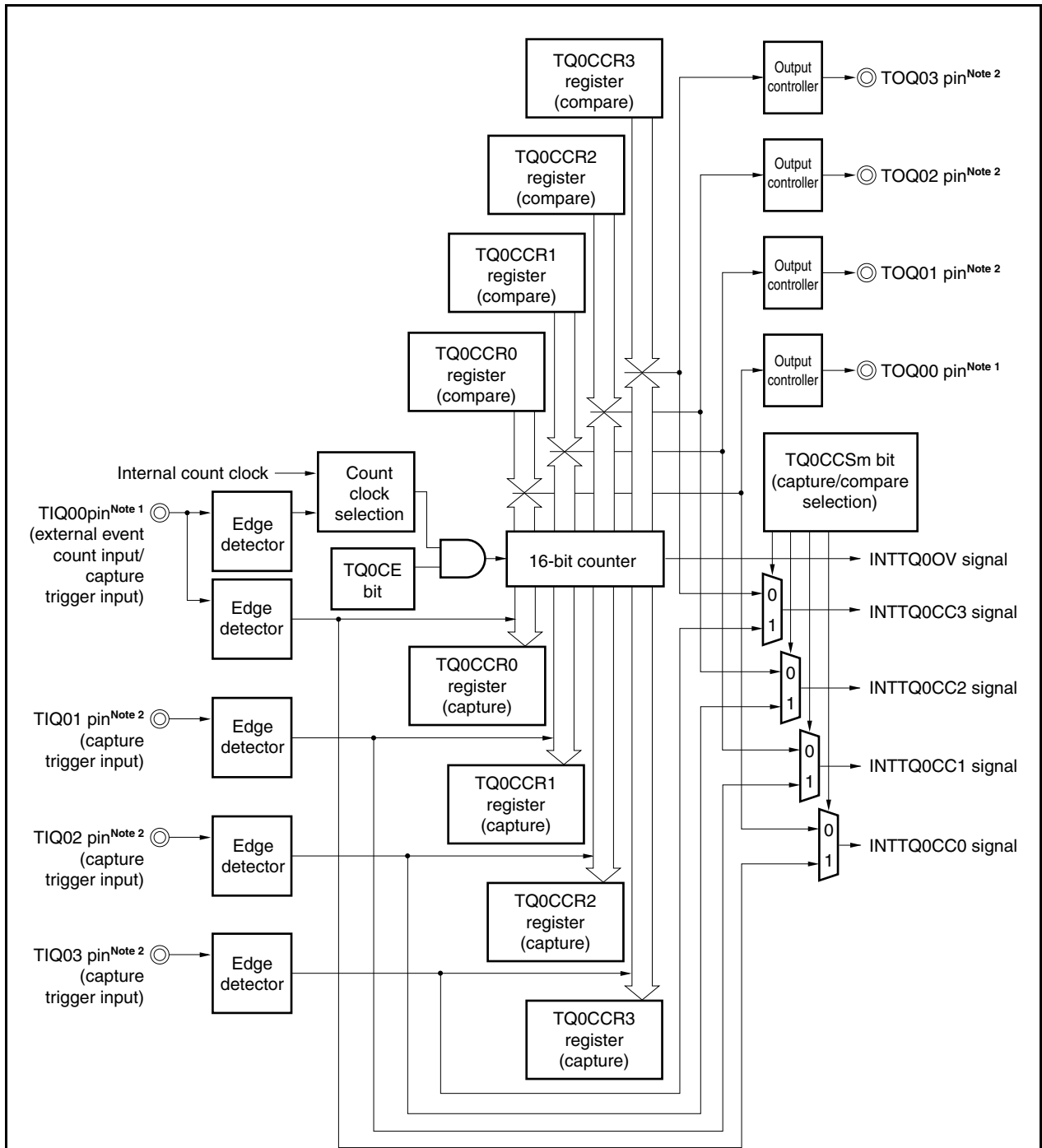

**Notes 1.** Because the external event count input pin (TIQ00), capture trigger input pin (TIQ00), and timer output pin (TOQ00) share the same alternate-function pin, two or more functions cannot be used at the same time.

**2.** Because the capture trigger input pin (TIQ0k) and external output pin (TOQ0k) share the same alternate-function pin, two or more functions cannot be used at the same time ( $k = 1$  to 3).

- Compare operation

When the TQ0CE bit is set to 1, 16-bit timer/event counter Q starts counting, and the output signals of the TOQ00 to TOQ03 pins are inverted. When the count value of the 16-bit counter later matches the set value of the TQ0CCRm register, a compare match interrupt request signal (INTTQ0CCm) is generated, and the output signal of the TOQ0m pin is inverted.

The 16-bit counter continues counting in synchronization with the count clock. When it counts up to FFFFH, it generates an overflow interrupt request signal (INTTQ0OV) at the next clock, is cleared to 0000H, and continues counting. At this time, the overflow flag (TQ0OPT0.TQ0OVF bit) is also set to 1. Confirm that the overflow flag is set to 1 and then clear it to 0 by executing the CLR instruction via software.

The TQ0CCRm register can be rewritten while the counter is operating. If it is rewritten, the new value is reflected immediately and compared with the count value.

**Remark** m = 0 to 3

**Figure 8-33. Basic Timing in Free-Running Timer Mode (Compare Function)**

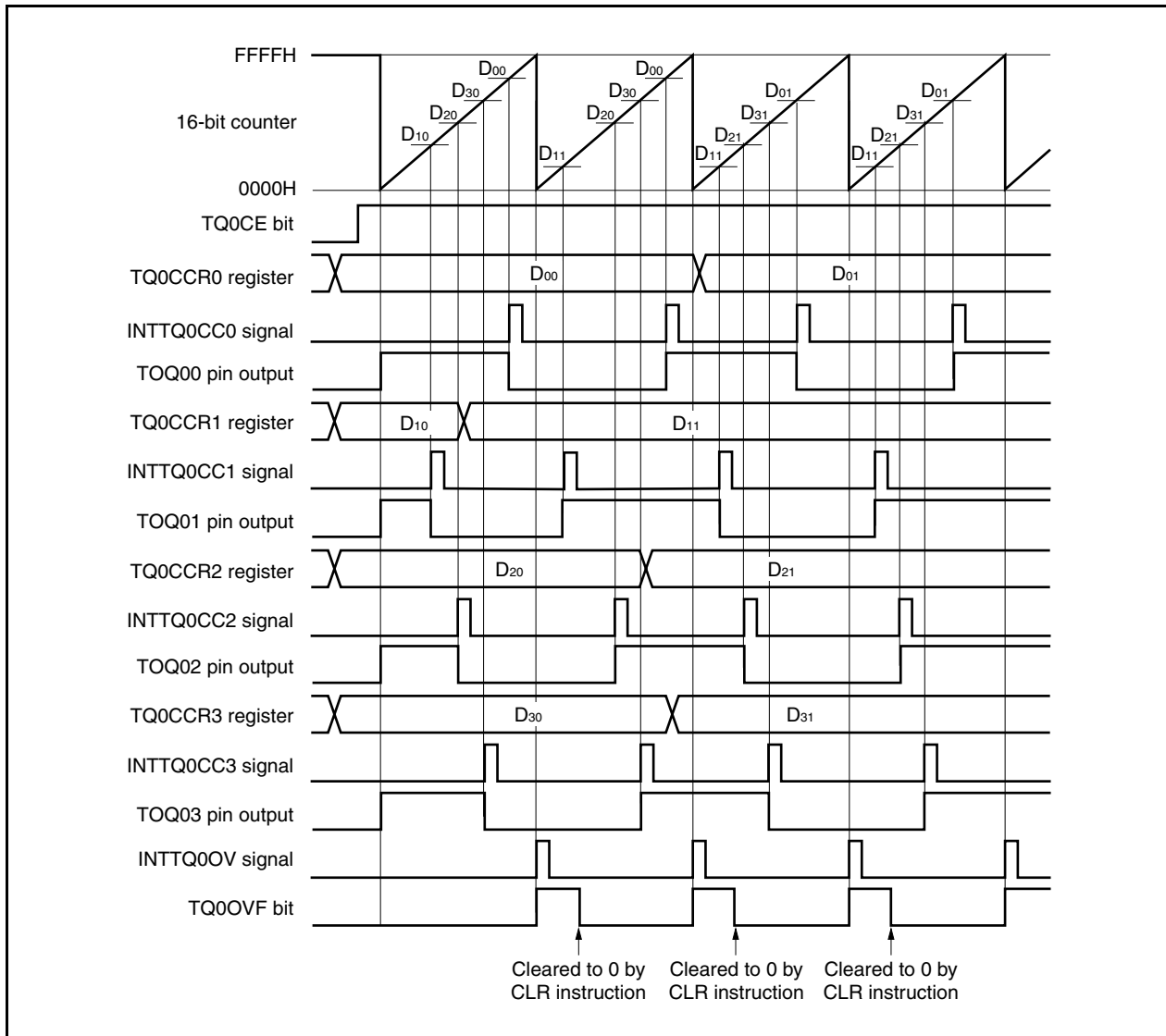

- Capture operation

When the TQ0CE bit is set to 1, the 16-bit counter starts counting. When the valid edge input to the TIQ0m pin is detected, the count value of the 16-bit counter is stored in the TQ0CCRm register, and a capture interrupt request signal (INTTQ0CCm) is generated.

The 16-bit counter continues counting in synchronization with the count clock. When it counts up to FFFFH, it generates an overflow interrupt request signal (INTTQ0OV) at the next clock, is cleared to 0000H, and continues counting. At this time, the overflow flag ((TQ0OPT0.TQ0OVF bit) is also set to 1. Confirm that the overflow flag is set to 1 and then clear it to 0 by executing the CLR instruction via software.

**Remark** m = 0 to 3

**Figure 8-34. Basic Timing in Free-Running Timer Mode (Capture Function)**

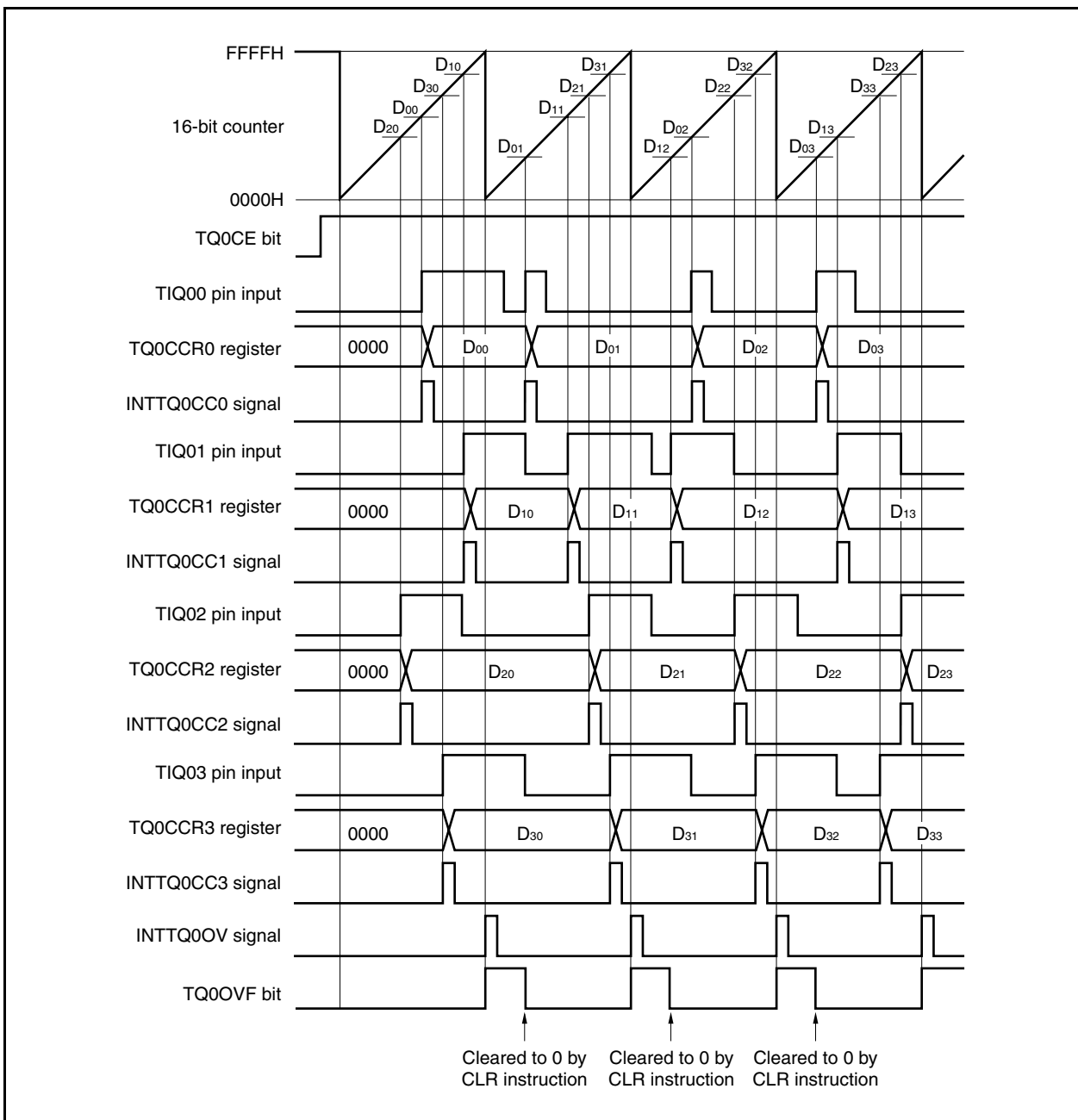
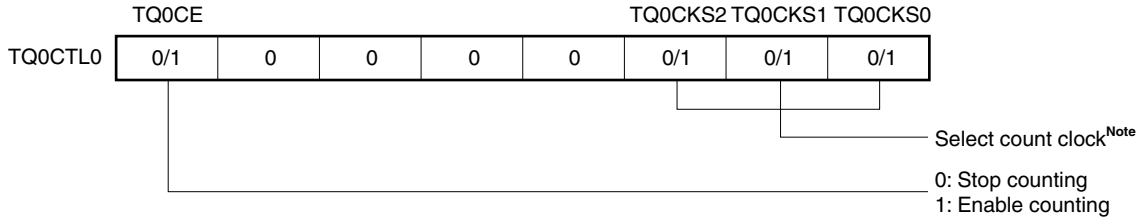

Figure 8-35. Register Setting in Free-Running Timer Mode (1/3)

(a) TMQ0 control register 0 (TQ0CTL0)



**Note** The setting is invalid when the TQ0CTL1.TQ0EEE bit = 1

(b) TMQ0 control register 1 (TQ0CTL1)

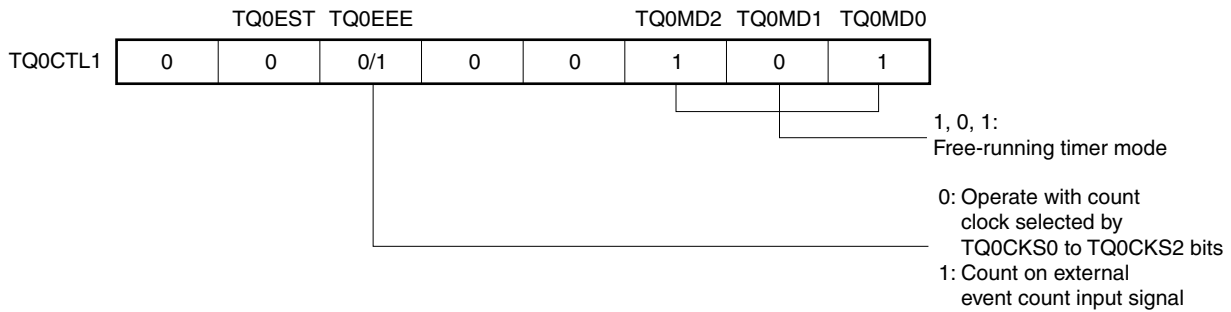

(c) TMQ0 I/O control register 0 (TQ0IOC0)

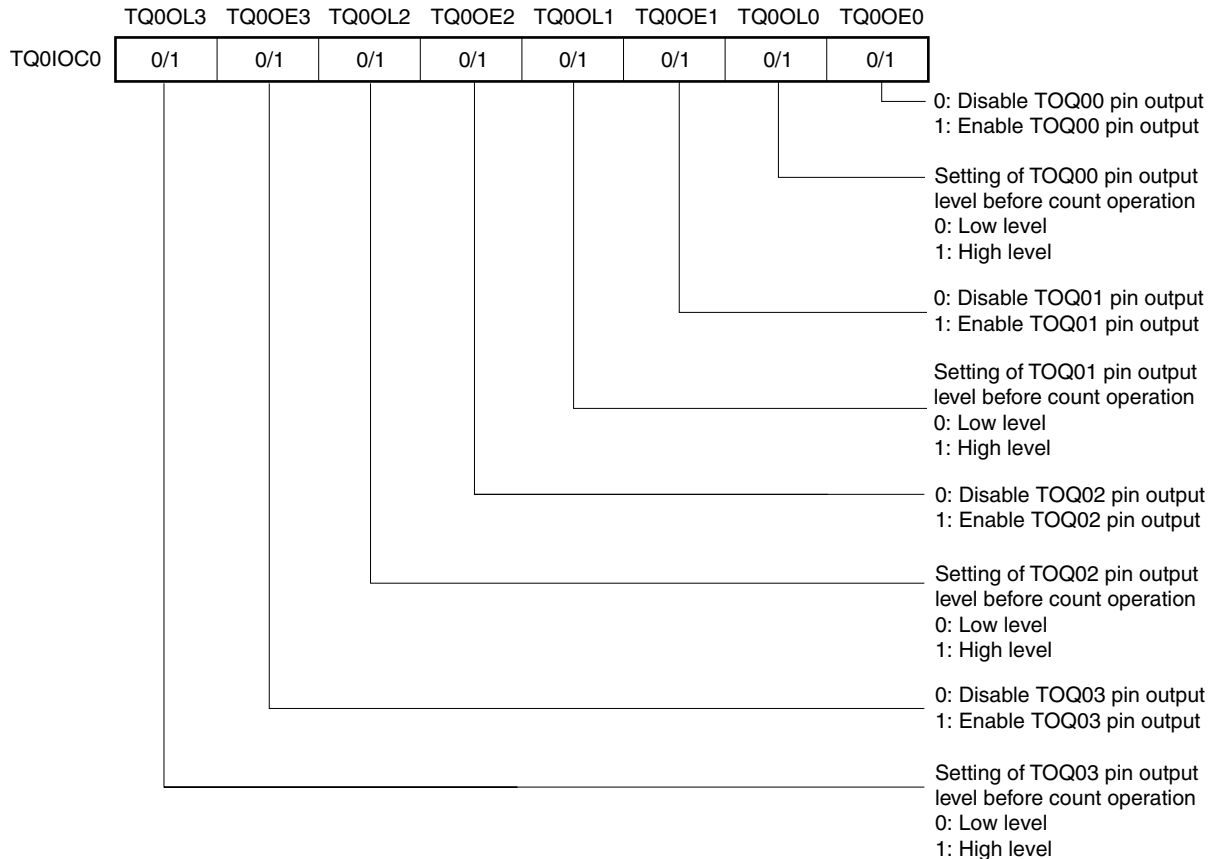

Figure 8-35. Register Setting in Free-Running Timer Mode (2/3)

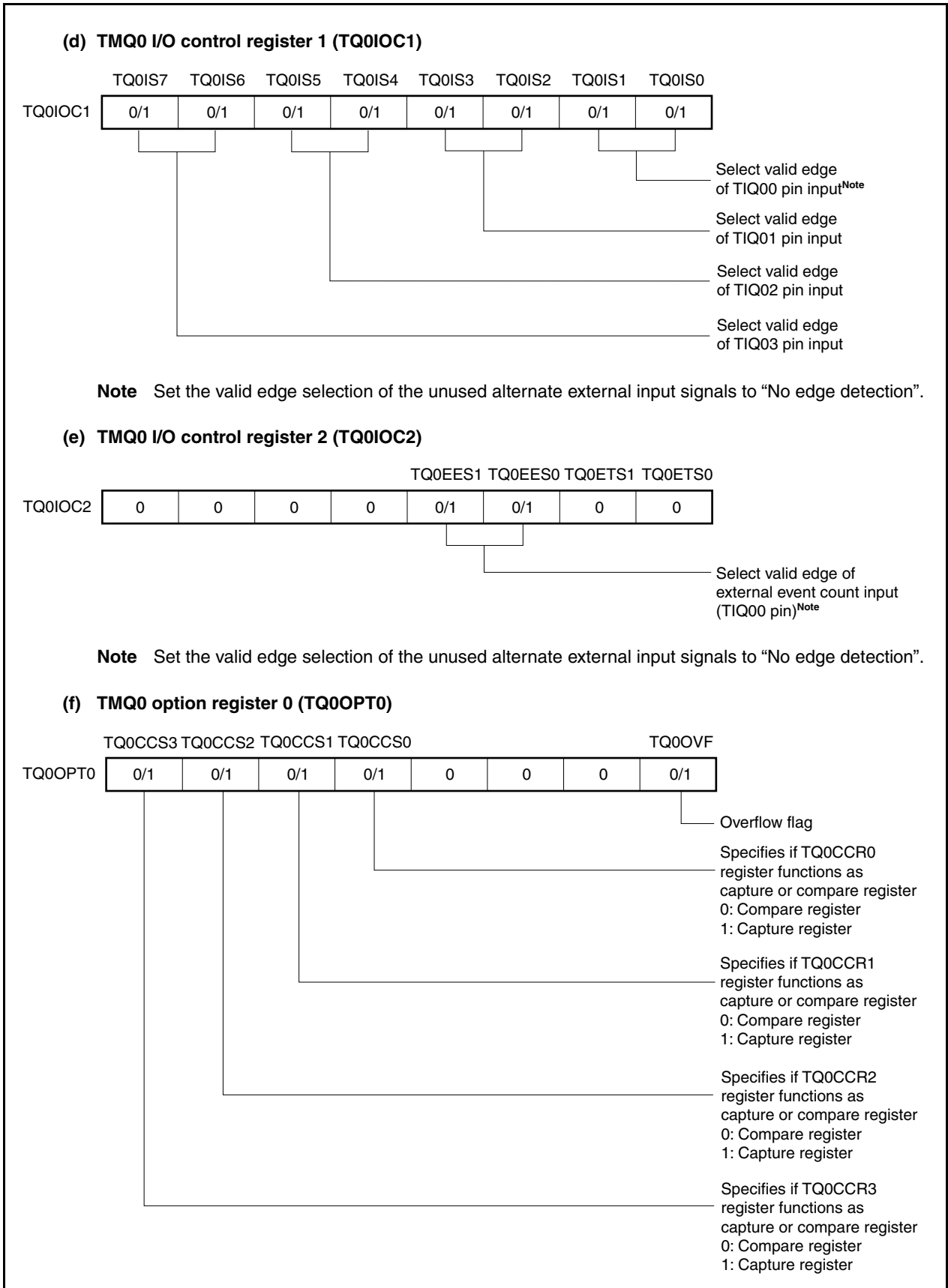

Figure 8-35. Register Setting in Free-Running Timer Mode (3/3)

**(g) TMQ0 counter read buffer register (TQ0CNT)**

The value of the 16-bit counter can be read by reading the TQ0CNT register.

**(h) TMQ0 capture/compare registers 0 to 3 (TQ0CCR0 to TQ0CCR3)**

These registers function as capture registers or compare registers depending on the setting of the TQ0OPT0.TQ0CCSm bit.

When the registers function as capture registers, they store the count value of the 16-bit counter when the valid edge input to the TIQ0m pin is detected.

When the registers function as compare registers and when  $D_m$  is set to the TQ0CCRm register, the INTTQ0CCm signal is generated when the counter reaches  $(D_m + 1)$ , and the output signal of the TOQ0m pin is inverted.

**Remark**  $m = 0$  to 3



(1) Operation flow in free-running timer mode

(a) When using capture/compare register as compare register

Figure 8-36. Software Processing Flow in Free-Running Timer Mode (Compare Function) (1/2)

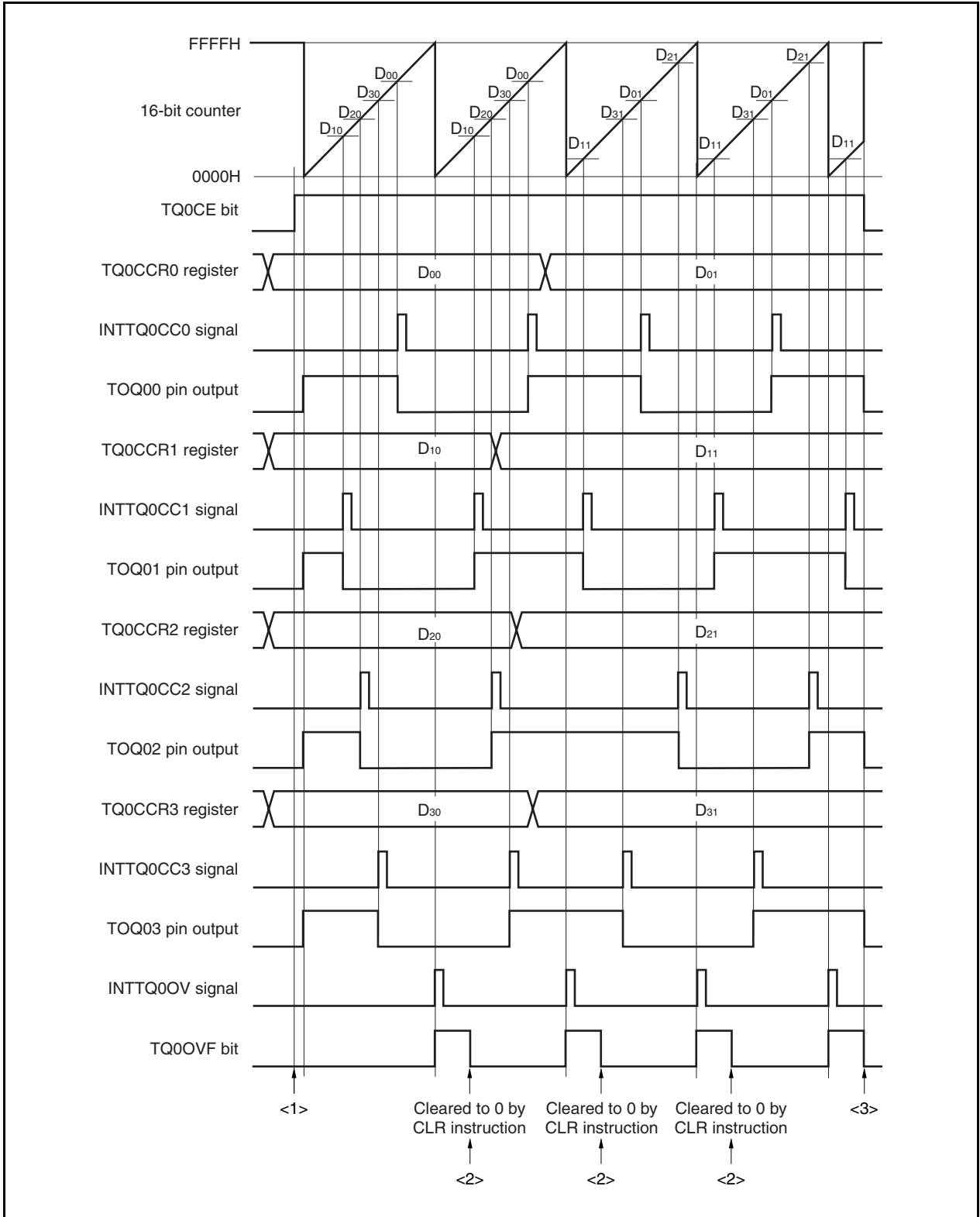
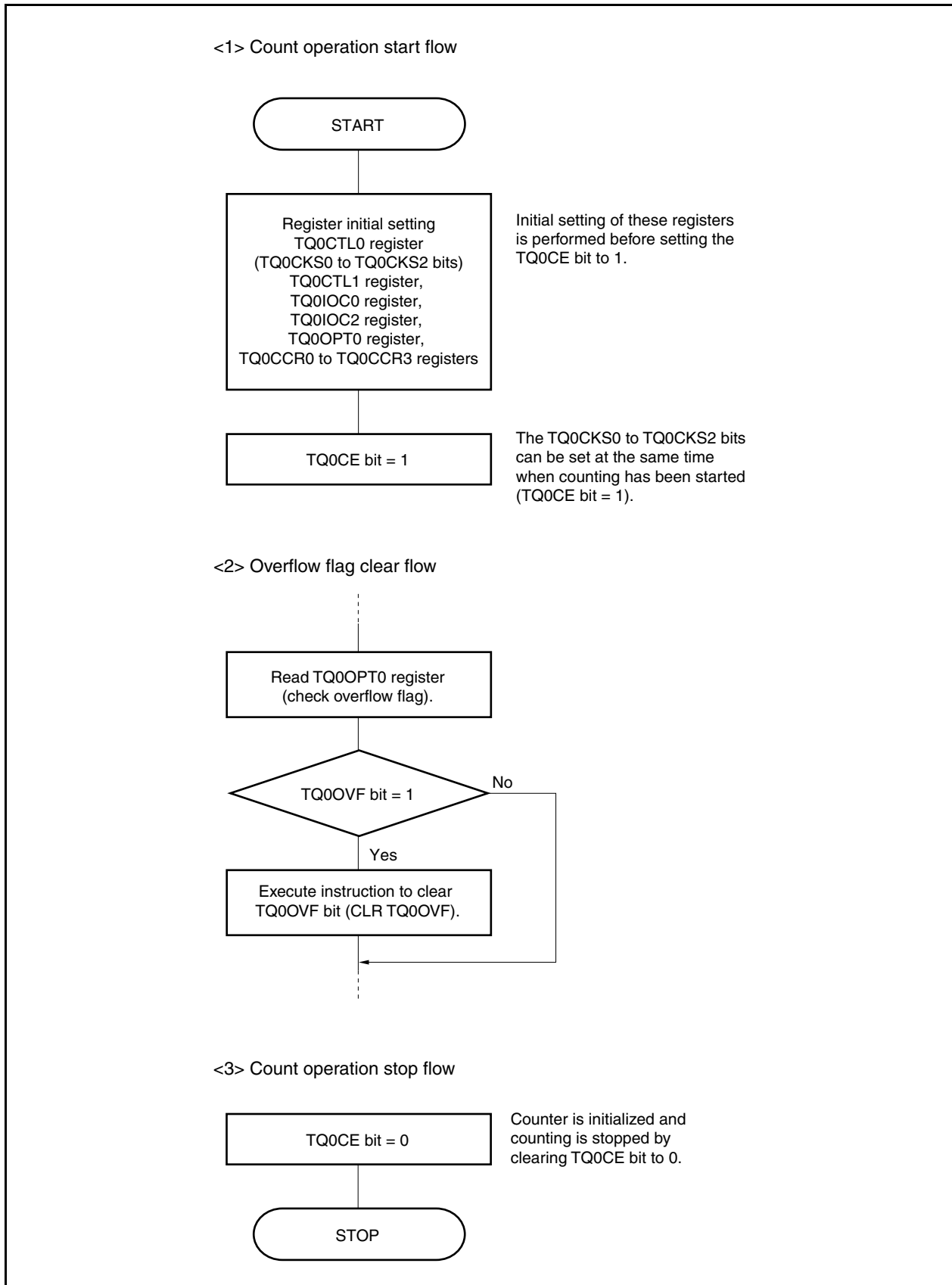

Figure 8-36. Software Processing Flow in Free-Running Timer Mode (Compare Function) (2/2)



(b) When using capture/compare register as capture register

Figure 8-37. Software Processing Flow in Free-Running Timer Mode (Capture Function) (1/2)

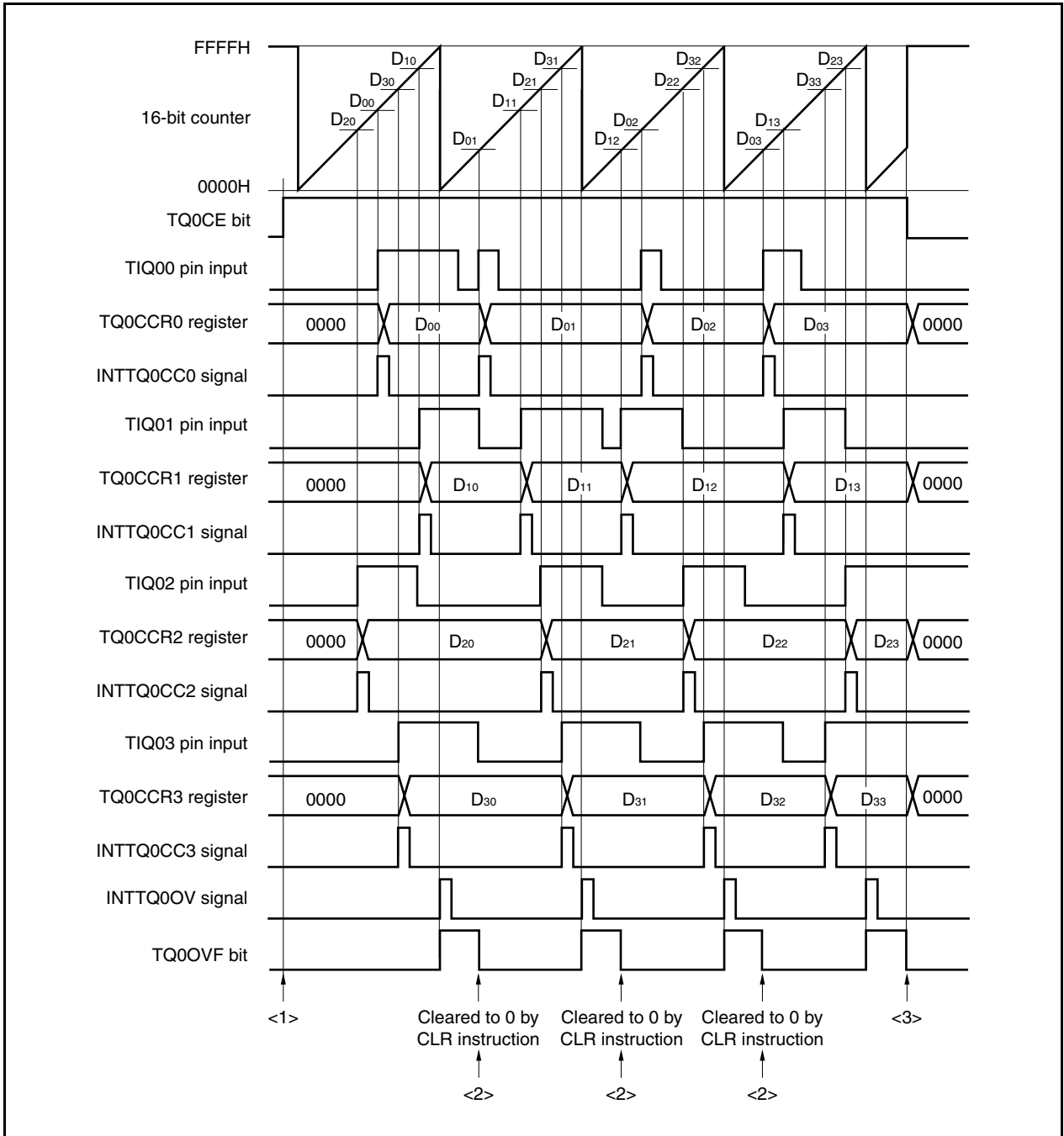
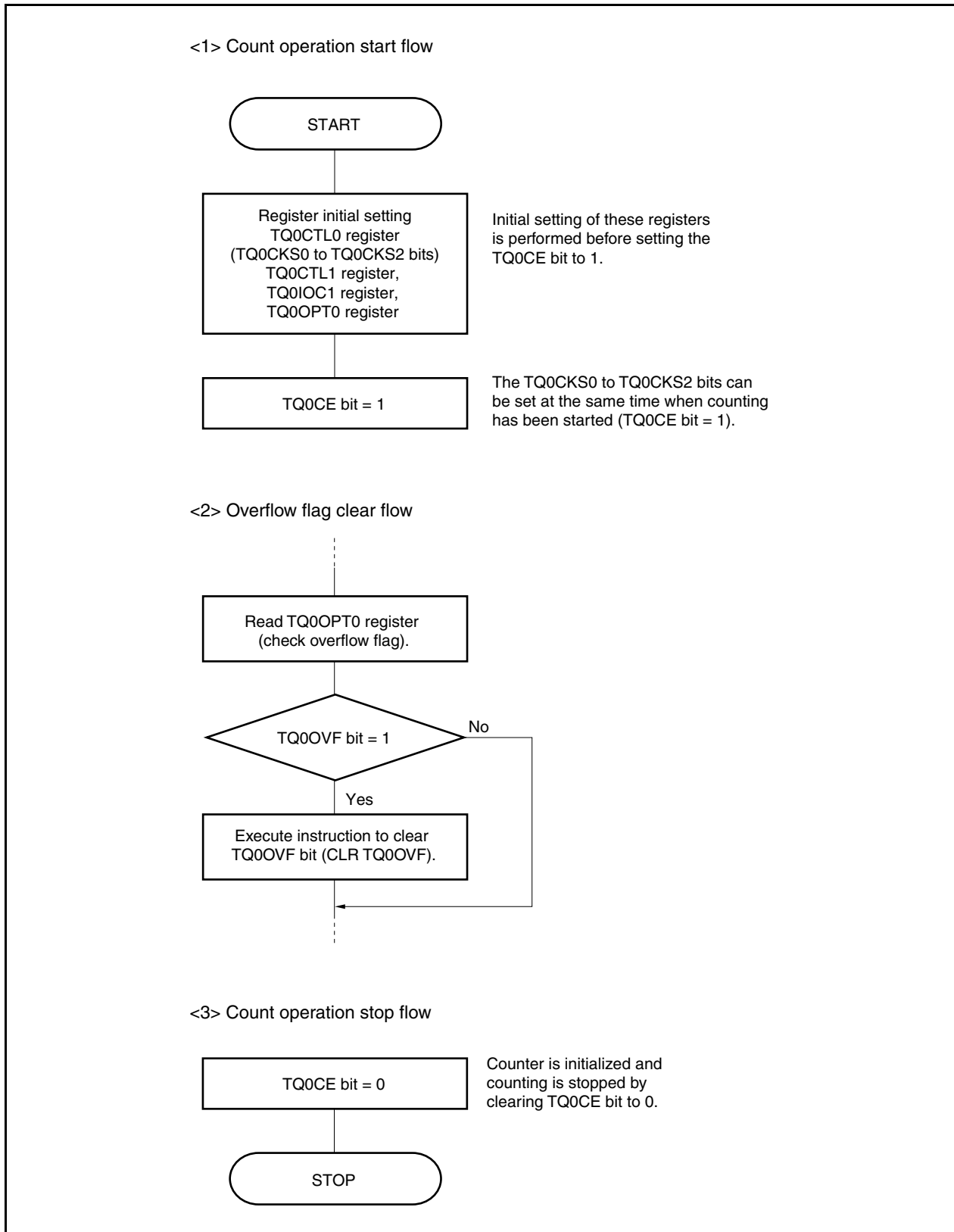

Figure 8-37. Software Processing Flow in Free-Running Timer Mode (Capture Function) (2/2)



(2) Operation timing in free-running timer mode

(a) Interval operation with compare register

When 16-bit timer/event counter Q is used as an interval timer with the TQ0CCRm register used as a compare register, software processing is necessary for setting a comparison value to generate the next interrupt request signal each time the INTTQ0CCm signal has been detected.

**Remark** m = 0 to 3

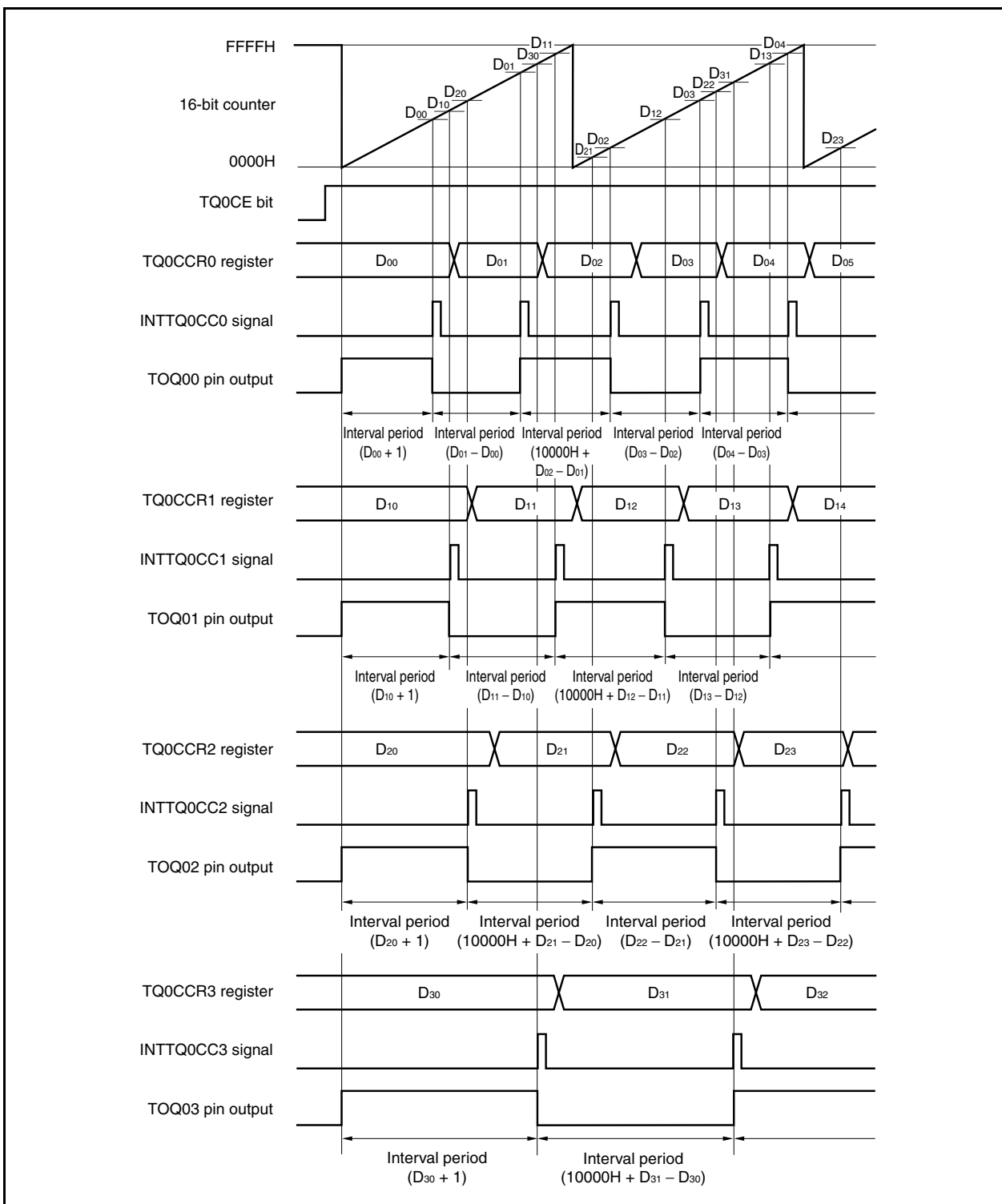

When performing an interval operation in the free-running timer mode, two intervals can be set with one channel.

To perform the interval operation, the value of the corresponding TQ0CCR<sub>m</sub> register must be re-set in the interrupt servicing that is executed when the INTTQ0CC<sub>m</sub> signal is detected.

The set value for re-setting the TQ0CCR<sub>m</sub> register can be calculated by the following expression, where “D<sub>m</sub>” is the interval period.

Compare register default value:  $D_m - 1$

Value set to compare register second and subsequent time: Previous set value +  $D_m$

(If the calculation result is greater than FFFFH, subtract 10000H from the result and set this value to the register.)

**Remark** m = 0 to 3

**(b) Pulse width measurement with capture register**

When pulse width measurement is performed with the TQ0CCRm register used as a capture register, software processing is necessary for reading the capture register each time the INTTQ0CCm signal has been detected and for calculating an interval.

**Remark** m = 0 to 3

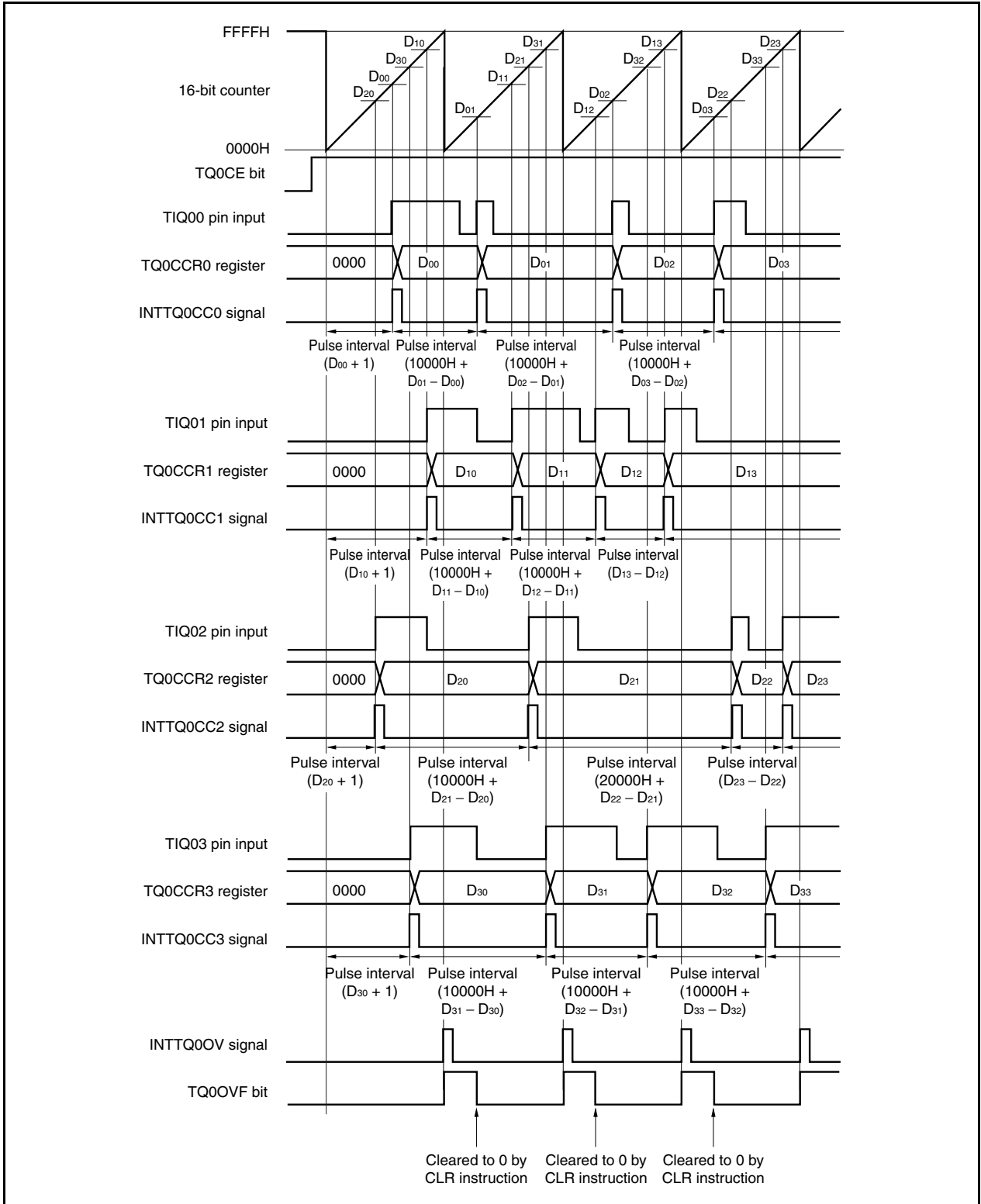

When executing pulse width measurement in the free-running timer mode, four pulse widths can be measured with one channel.

To measure a pulse width, the pulse width can be calculated by reading the value of the TQ0CCRm register in synchronization with the INTTQ0CCm signal, and calculating the difference between the read value and the previously read value.

**Remark** m = 0 to 3



**(c) Processing of overflow when two or more capture registers are used**

Care must be exercised in processing the overflow flag when two capture registers are used. First, an example of incorrect processing is shown below.

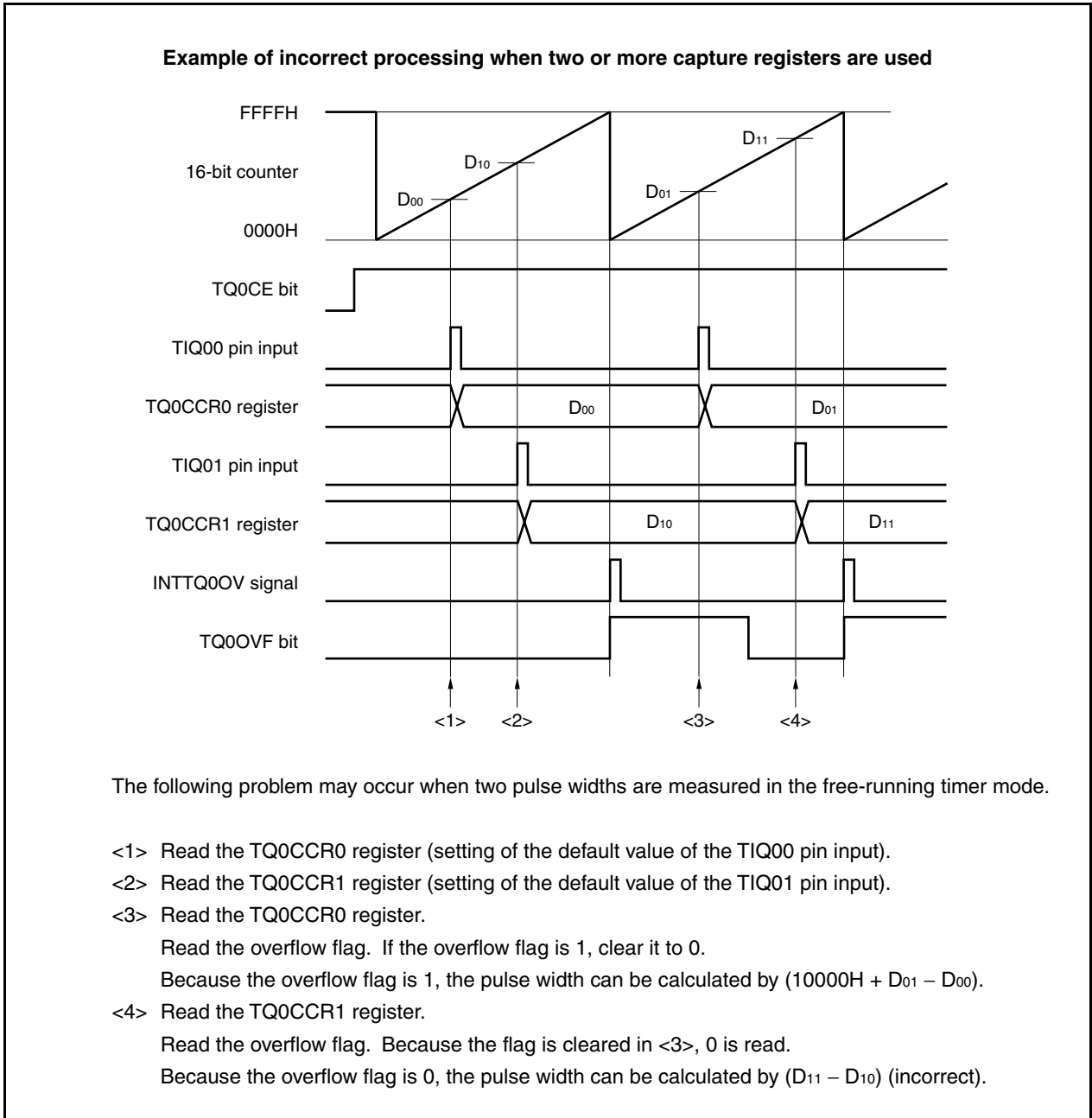

When two capture registers are used, and if the overflow flag is cleared to 0 by one capture register, the other capture register may not obtain the correct pulse width.

Use software when using two capture registers. An example of how to use software is shown below.

### Example when two capture registers are used (using overflow interrupt)

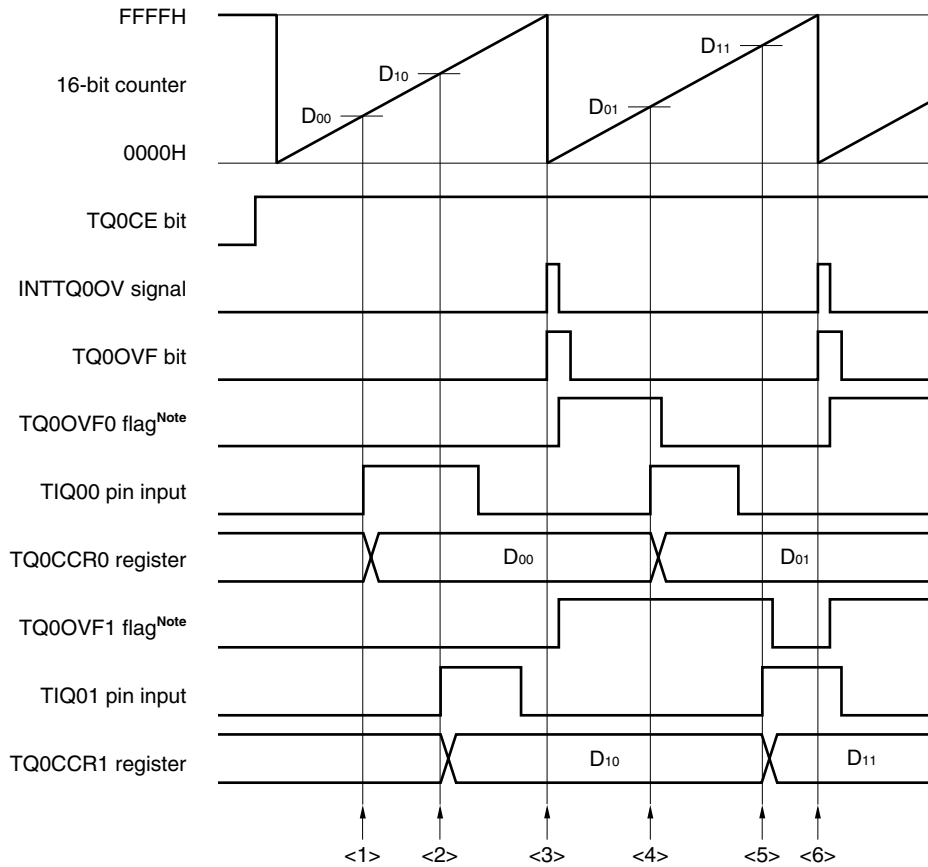

**Note** The TQ0OVF0 and TQ0OVF1 flags are set on the internal RAM by software.

- <1> Read the TQ0CCR0 register (setting of the default value of the TIQ00 pin input).
- <2> Read the TQ0CCR1 register (setting of the default value of the TIQ01 pin input).
- <3> An overflow occurs. Set the TQ0OVF0 and TQ0OVF1 flags to 1 in the overflow interrupt servicing, and clear the overflow flag to 0.
- <4> Read the TQ0CCR0 register.  
Read the TQ0OVF0 flag. If the TQ0OVF0 flag is 1, clear it to 0.  
Because the TQ0OVF0 flag is 1, the pulse width can be calculated by  $(10000H + D_{01} - D_{00})$ .
- <5> Read the TQ0CCR1 register.  
Read the TQ0OVF1 flag. If the TQ0OVF1 flag is 1, clear it to 0 (the TQ0OVF0 flag is cleared in <4>, and the TQ0OVF1 flag remains 1).  
Because the TQ0OVF1 flag is 1, the pulse width can be calculated by  $(10000H + D_{11} - D_{10})$  (correct).
- <6> Same as <3>

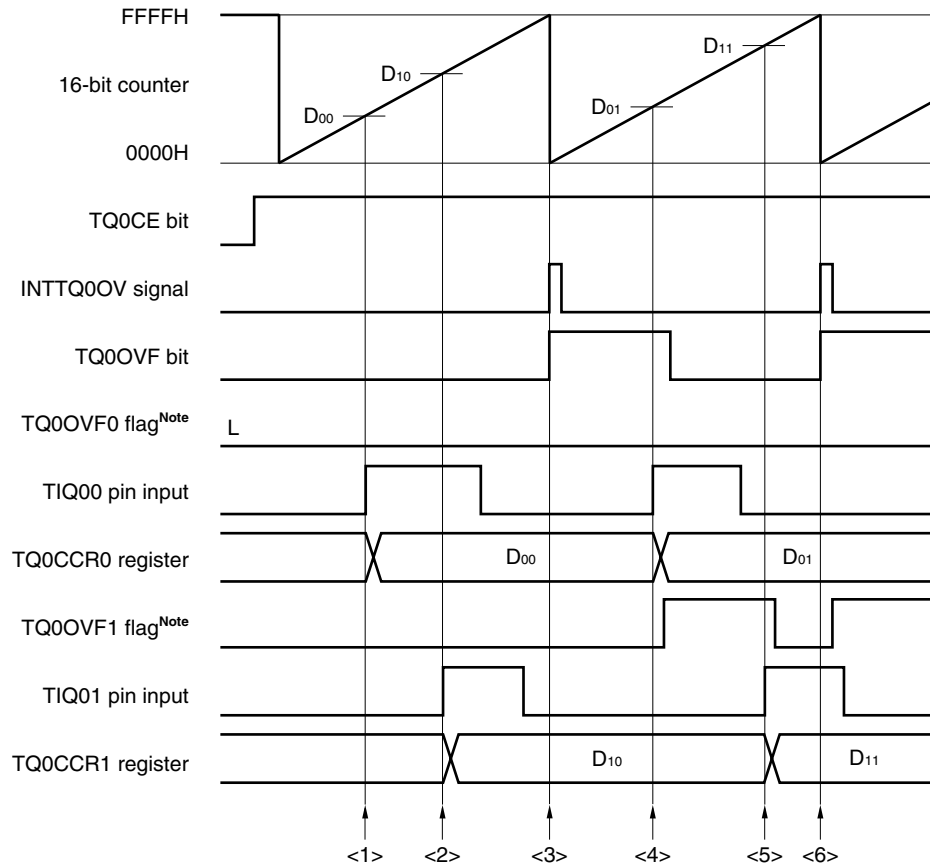
**Example when two capture registers are used (without using overflow interrupt)**

**Note** The TQ0OVF0 and TQ0OVF1 flags are set on the internal RAM by software.

<1> Read the TQ0CCR0 register (setting of the default value of the TIQ00 pin input).

<2> Read the TQ0CCR1 register (setting of the default value of the TIQ01 pin input).

<3> An overflow occurs. Nothing is done by software.

<4> Read the TQ0CCR0 register.

Read the overflow flag. If the overflow flag is 1, set only the TQ0OVF1 flag to 1, and clear the overflow flag to 0.

Because the overflow flag is 1, the pulse width can be calculated by  $(10000H + D_{01} - D_{00})$ .

<5> Read the TQ0CCR1 register.

Read the overflow flag. Because the overflow flag is cleared in <4>, 0 is read.

Read the TQ0OVF1 flag. If the TQ0OVF1 flag is 1, clear it to 0.

Because the TQ0OVF1 flag is 1, the pulse width can be calculated by  $(10000H + D_{11} - D_{10})$  (correct).

<6> Same as <3>

**(d) Processing of overflow if capture trigger interval is long**

If the pulse width is greater than one cycle of the 16-bit counter, care must be exercised because an overflow may occur more than once from the first capture trigger to the next. First, an example of incorrect processing is shown below.

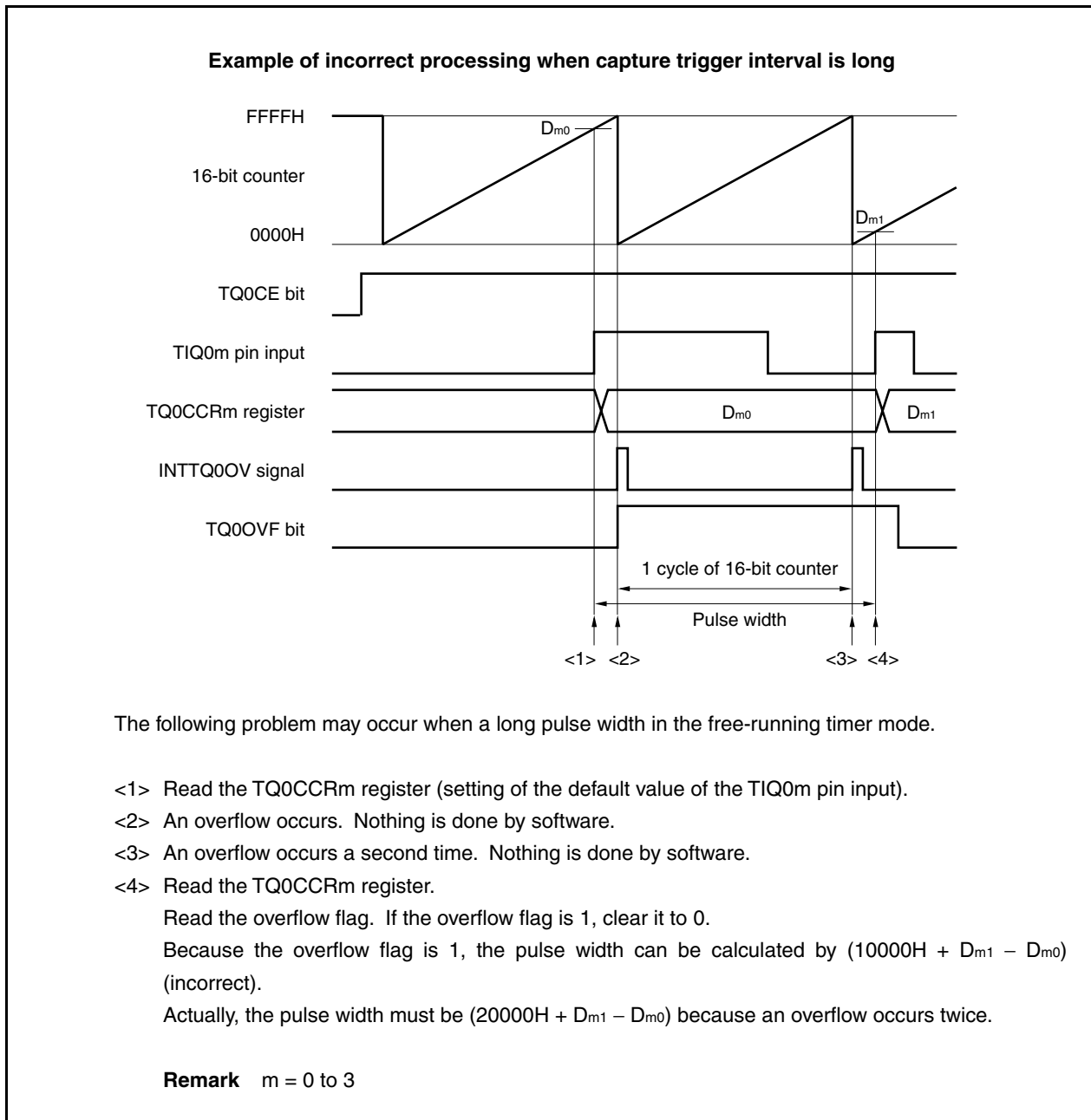

If an overflow occurs twice or more when the capture trigger interval is long, the correct pulse width may not be obtained.

If the capture trigger interval is long, slow the count clock to lengthen one cycle of the 16-bit counter, or use software. An example of how to use software is shown next.

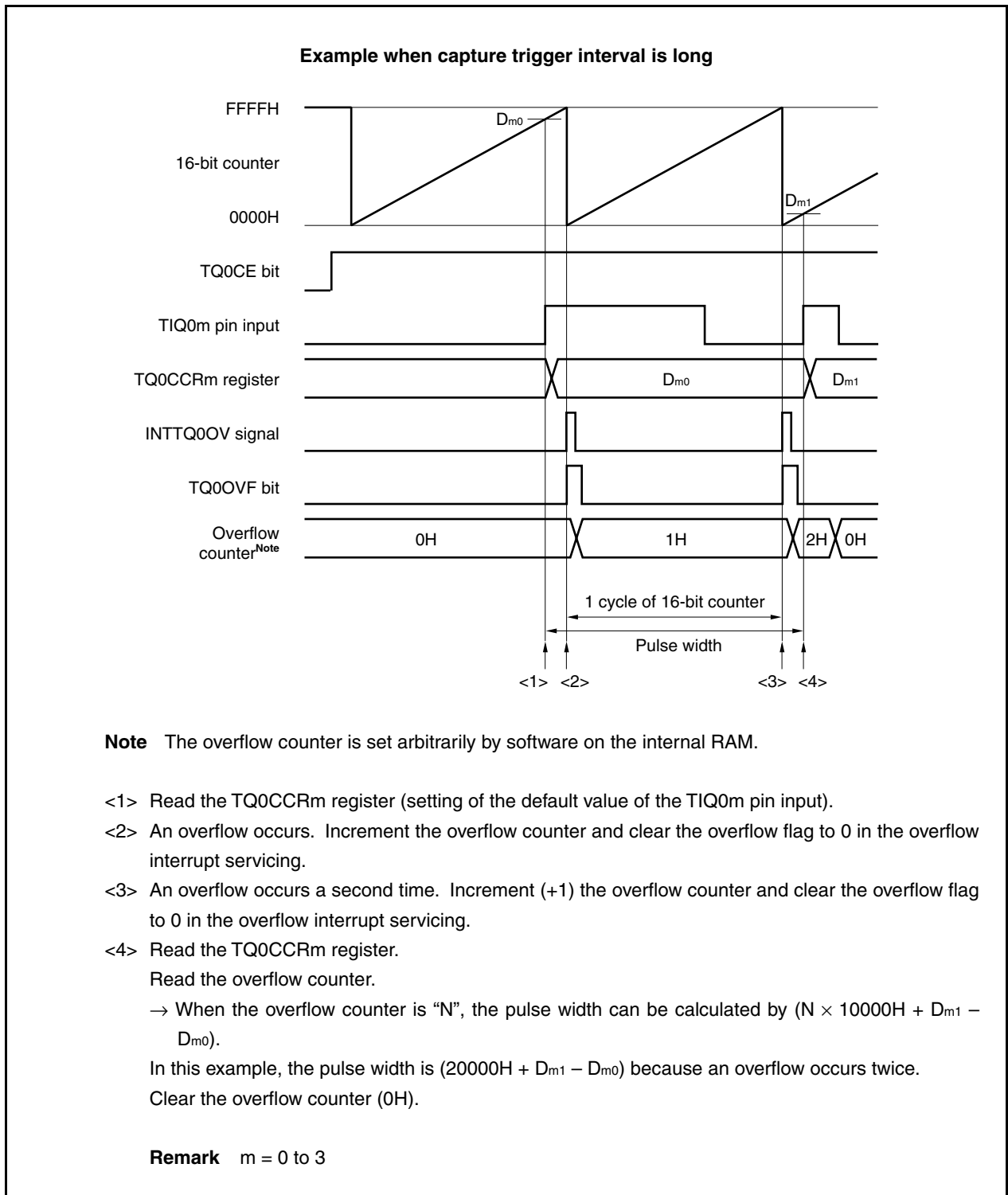
**(e) Clearing overflow flag**

The overflow flag can be cleared to 0 by clearing the TQ0OVF bit to 0 with the CLR instruction after reading TQ0OVF bit = 1 and by writing 8-bit data (bit 0 is 0) to the TQ0OPT0 register after reading TQ0OVF bit = 1.

**(3) Note on capture operation**

If the capture operation is used and if a slow clock is selected as the count clock, FFFFH, not 0000H, may be captured to the TQ0CCRm register, or the capture operation may not be performed (capture interrupt does not occur) if the capture trigger is input immediately after the TQ0CTL0.TQ0CE bit is set to 1 (m = 0 to 3).

The same operation results during the period in which no external event counts are input while the capture operation is used and an external event count input is used as a count clock.

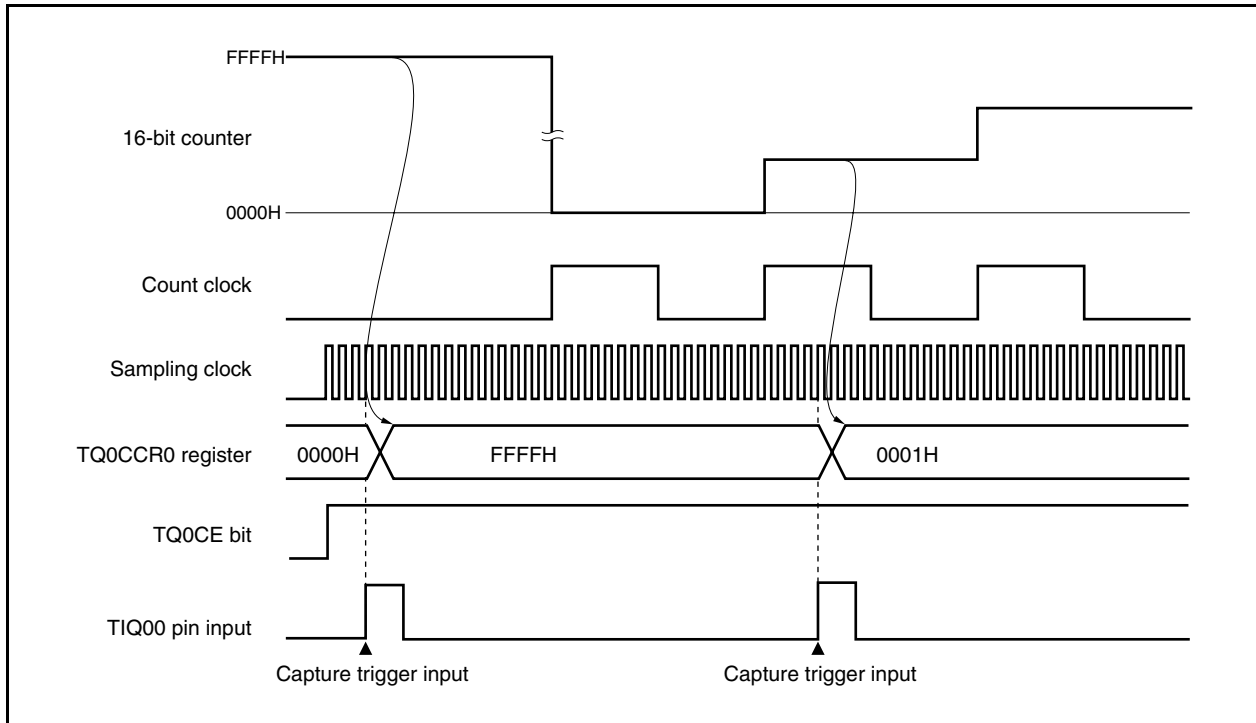

### 8.6.7 Pulse width measurement mode (TQ0MD2 to TQ0MD0 bits = 110)

In the pulse width measurement mode, 16-bit timer/event counter Q starts counting when the TQ0CTL0.TQ0CE bit is set to 1. Each time the valid edge input to the TIQ0m pin has been detected, the count value of the 16-bit counter is stored in the TQ0CCRm register, and the 16-bit counter is cleared to 0000H.

The interval of the valid edge can be measured by reading the TQ0CCRm register after a capture interrupt request signal (INTTQ0CCm) occurs.

In case of Figure 8-39, select either of the TIQ00 to TIQ03 pins as the capture trigger input pin. Specify “No edge detected” by using the TQ0IOC1 register for the unused pins.

**Remark** m = 0 to 3  
k = 1 to 3

**Figure 8-38. Configuration in Pulse Width Measurement Mode**

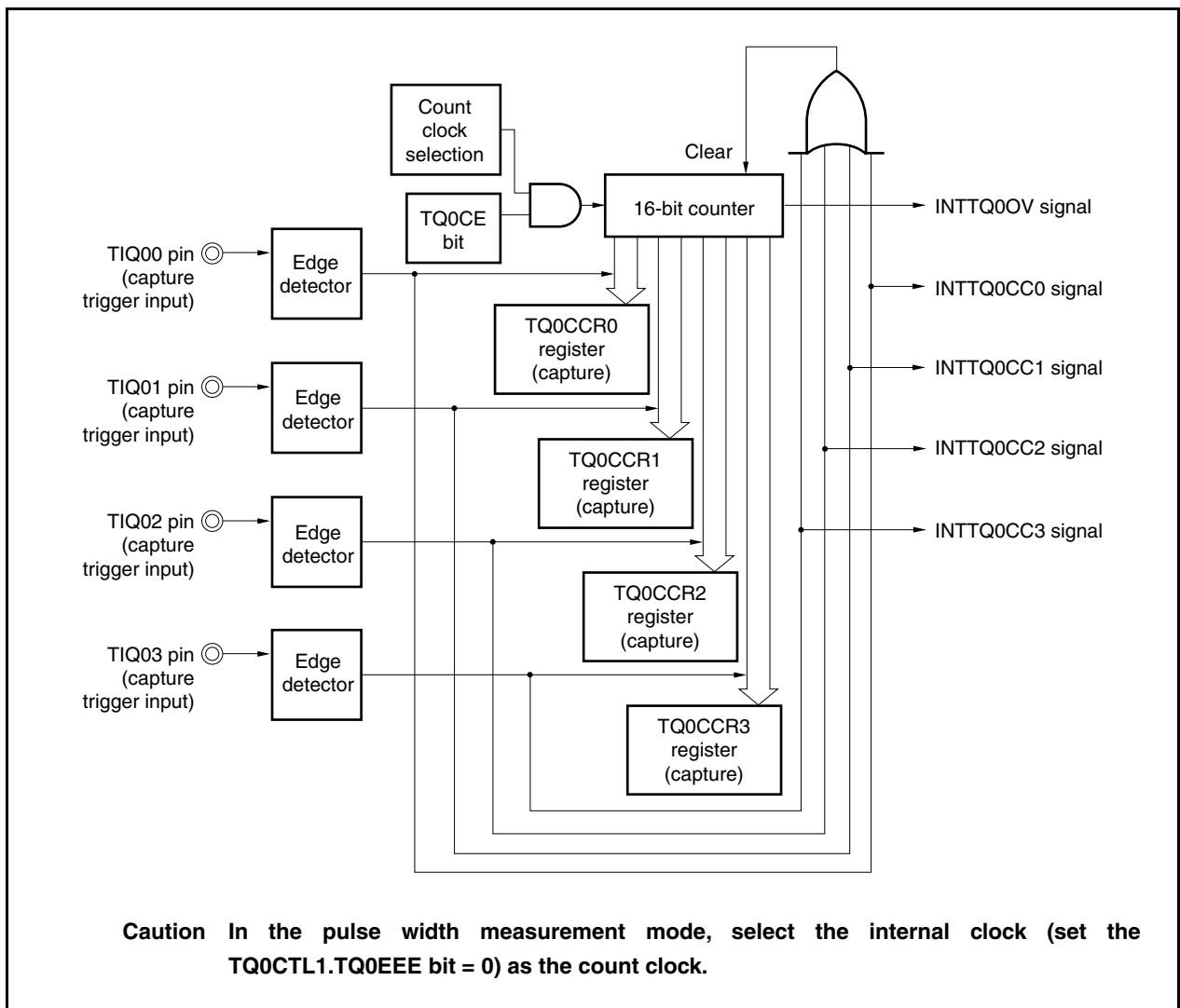
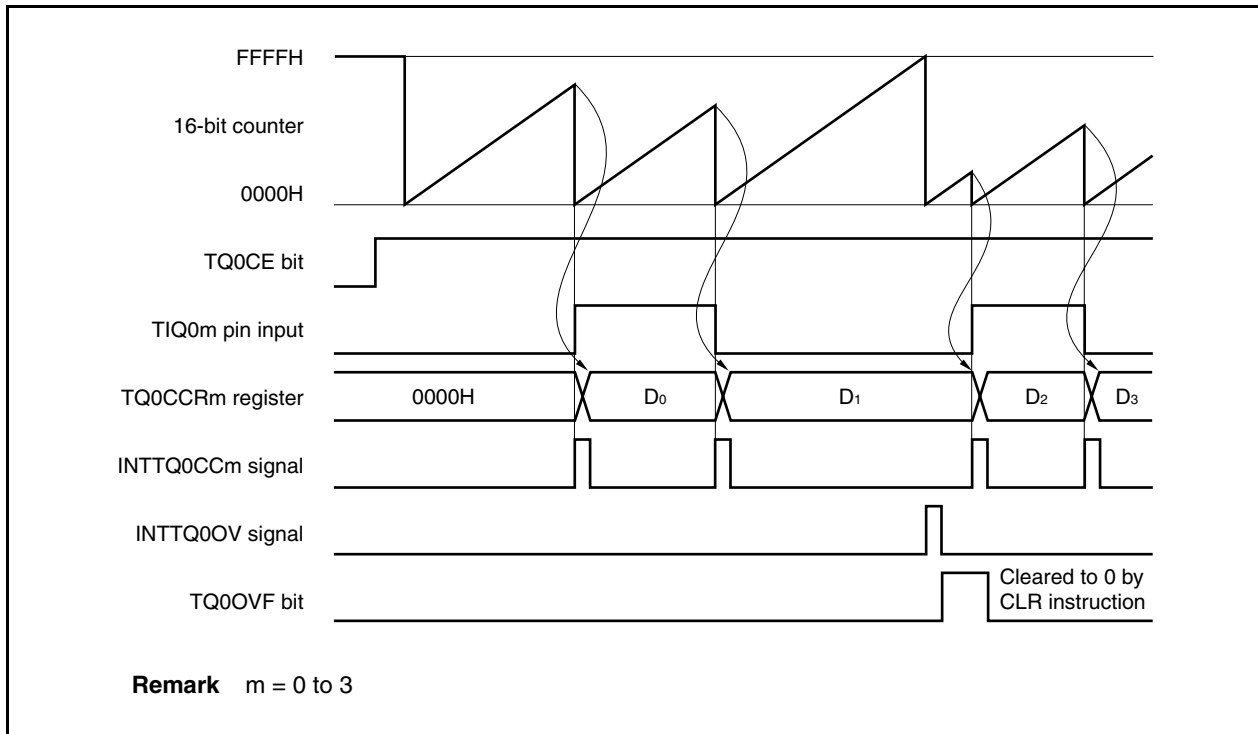

Figure 8-39. Basic Timing in Pulse Width Measurement Mode



When the TQ0CE bit is set to 1, the 16-bit counter starts counting. When the valid edge input to the TIQ0m pin is later detected, the count value of the 16-bit counter is stored in the TQ0CCRm register, the 16-bit counter is cleared to 0000H, and a capture interrupt request signal (INTTQ0CCm) is generated.

The pulse width is calculated as follows.

$$\text{Pulse width} = \text{Captured value} \times \text{Count clock cycle}$$

If the valid edge is not input to the TIQ0m pin even when the 16-bit counter counted up to FFFFH, an overflow interrupt request signal (INTTQ0OV) is generated at the next count clock, and the counter is cleared to 0000H and continues counting. At this time, the overflow flag (TQ0OPT0.TQ0OVF bit) is also set to 1. Clear the overflow flag to 0 by executing the CLR instruction via software.

If the overflow flag is set to 1, the pulse width can be calculated as follows.

$$\text{Pulse width} = (10000\text{H} \times \text{TQ0OVF bit set (1) count} + \text{Captured value}) \times \text{Count clock cycle}$$

**Remark** m = 0 to 3



Figure 8-40. Register Setting in Pulse Width Measurement Mode (1/2)

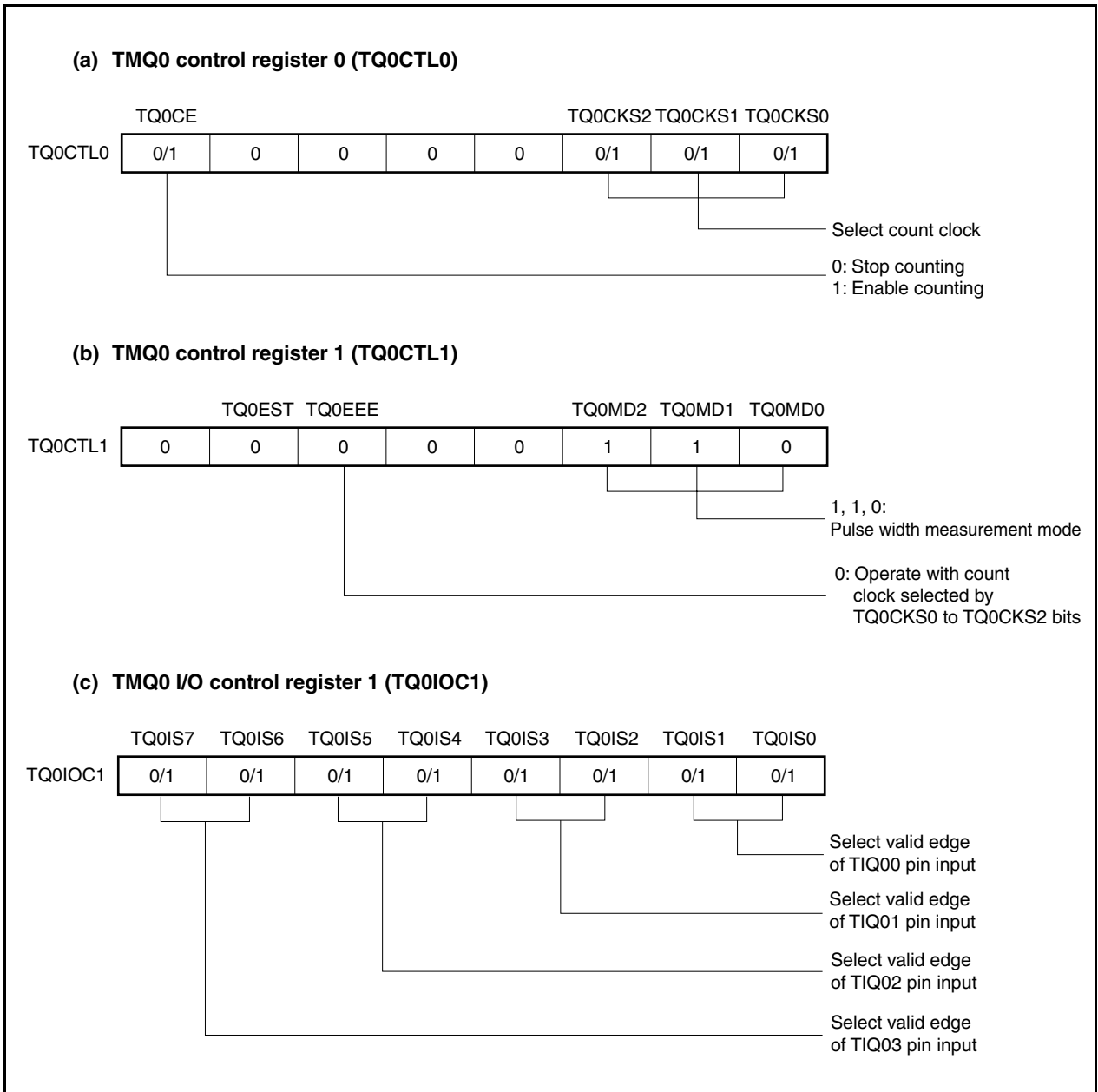
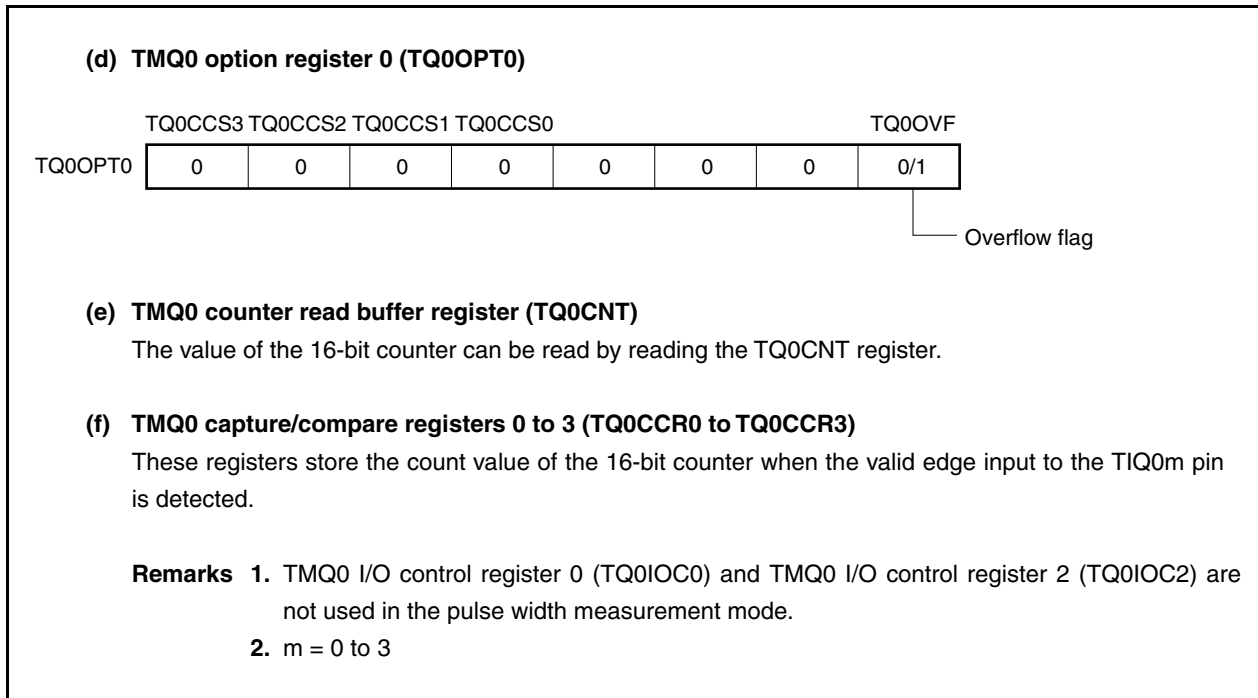
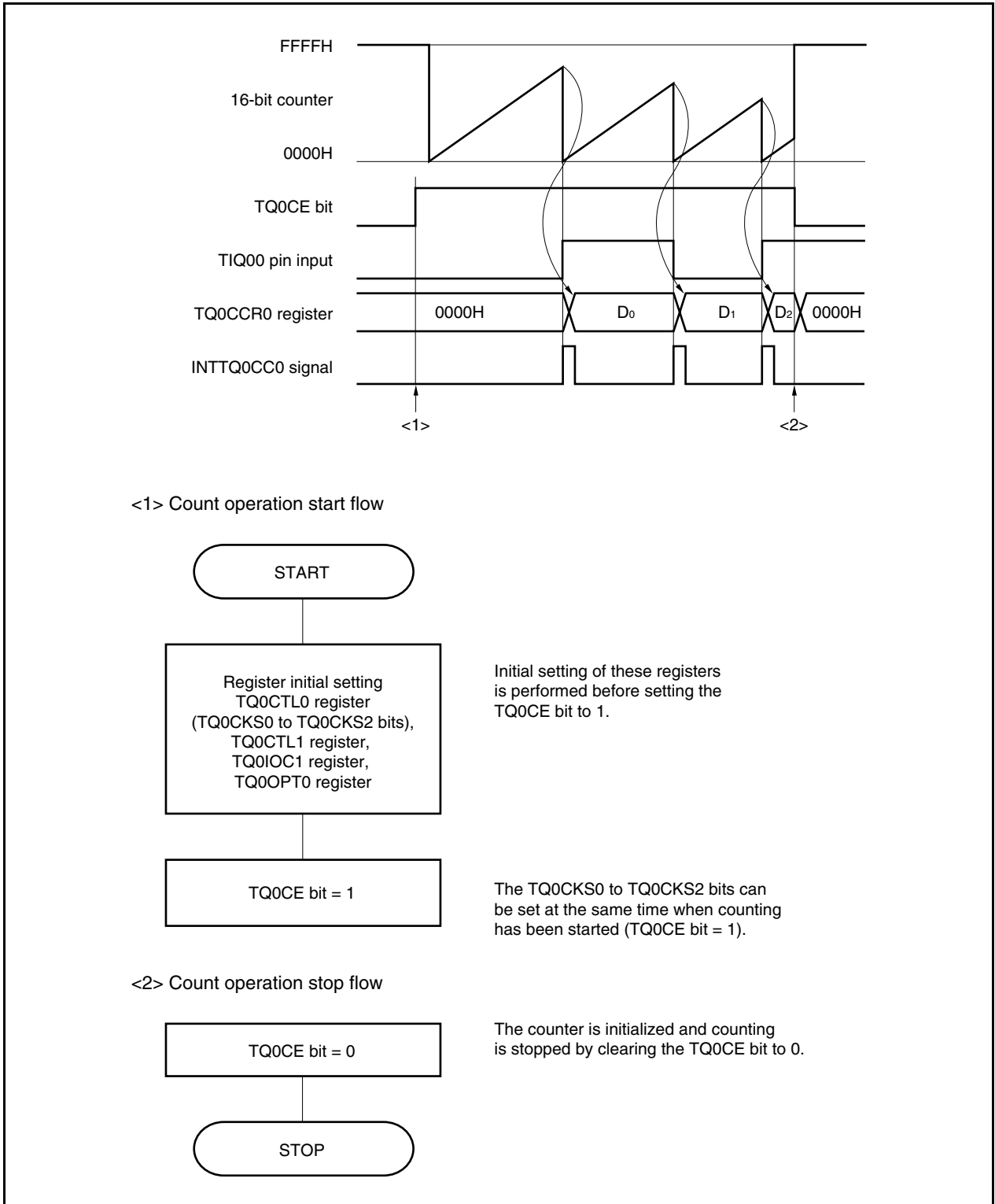

Figure 8-40. Register Setting in Pulse Width Measurement Mode (2/2)



(1) Operation flow in pulse width measurement mode

Figure 8-41. Software Processing Flow in Pulse Width Measurement Mode



**(2) Operation timing in pulse width measurement mode****(a) Clearing overflow flag**

The overflow flag can be cleared to 0 by clearing the TQ0OVF bit to 0 with the CLR instruction after reading the TQ0OVF bit when it is 1 and by writing 8-bit data (bit 0 is 0) to the TQ0OPT0 register after reading the TQ0OVF bit when it is 1.

**(3) Note**

If a slow clock is selected as the count clock, FFFFH, not 0000H, may be captured to the TQ0CCRm register, or the capture operation may not be performed (capture interrupt does not occur) if the capture trigger is input immediately after the TQ0CTL0.TQ0CE bit is set to 1 (m = 0 to 3).

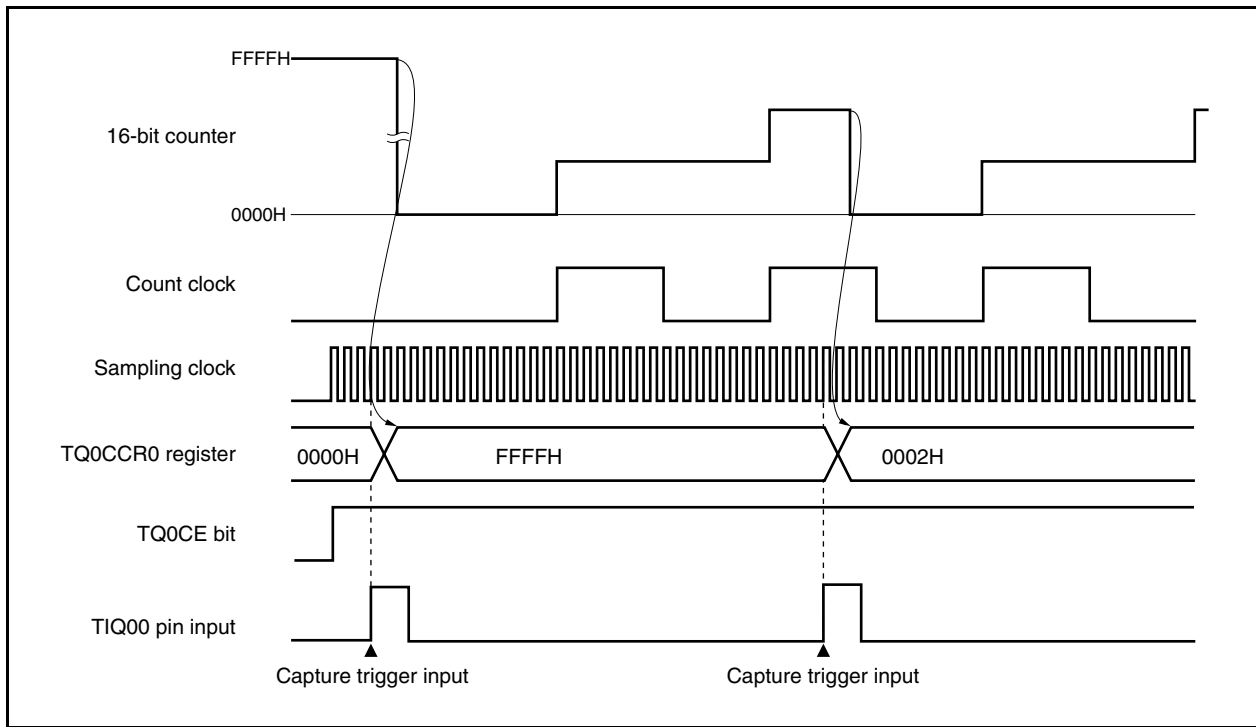
**8.7 Selector Function**

For the selector functions, see **7.7 Selector Function**.

## 8.8 Cautions

### (1) Switching of DMA transfer start factor

In the V850E/SJ3-H and V850E/SK3-H, the INTTQ0OV and INTUB0TIR signals, which are the DMA transfer start factors, share the same pin, and they cannot be used at the same time. To use the INTTQ0OV signal as the DMA transfer start factor, set the DTFROB0 bit of the option byte 0000007AH to 0 (refer to **CHAPTER 33 OPTION BYTE FUNCTION**). In this case, the INTUB0TIR signal cannot be used as the DMA transfer start factor.

**Remark** For details, see **Table 22-1 DMA Transfer Start Factors**.

### (2) Using TIQ0m pin and KRn pin at the same time

The TIQ0m pin and the KRn pin cannot be used at the same time ( $m = 0$  to  $3$ ,  $n = 0$  to  $3$ ). Although the TIQ00/KR3 pin and the TIQ03/KR2 pin are assigned to two different ports each, the pins cannot be used at the same time at different ports.

The following shows the settings when the TIQ0m pin is used and when the KRn pin is used.

Pin Name	When Used As TIQ0m Pin	When Used As KRn Pin
KR0/TIQ01	KRM.KRM0 bit = 0	TQ0IOC1.TQ0IS3, TQ0IS2 bits = 00
KR1/TIQ02	KRM.KRM1 bit = 0	TQ0IOC1.TQ0IS5, TQ0IS4 bits = 00
KR2/TIQ03	KRM.KRM2 bit = 0	TQ0IOC1.TQ0IS7, TQ0IS6 bits = 00
KR3/TIQ00	KRM.KRM3 bit = 0	TQ0IOC1.TQ0IS1, TQ0IS0 bits = 00 TQ0IOC2.TQ0EES1, TQ0EES0 bits = 00 TQ0IOC2.TQ0ETS1, TQ0ETS0 bits = 00

## CHAPTER 9 16-BIT INTERVAL TIMER M (TMM)

Timer M (TMM) is a 16-bit interval timer.

The V850E/SJ3-H and V850E/SK3-H incorporate TMM0 to TMM2.

### 9.1 Overview

The TMM<sub>n</sub> has the following functions (n = 0 to 2).

- Interval function
- 8 clocks selectable
- 16-bit counter × 1  
(The 16-bit counter cannot be read during timer count operation.)
- Compare register × 1  
(The compare register cannot be written during timer counter operation.)
- Compare match interrupt × 1

Timer M supports only the clear & start mode. The free-running timer mode is not supported.

## 9.2 Configuration

TMMn includes the following hardware (n = 0 to 2).

**Table 9-1. Configuration of TMMn**

Item	Configuration
Timer register	16-bit counter
Register	TMMn compare register 0 (TMnCMP0)
Control register	TMMn control register 0 (TMnCTL0)

**Remark** n = 0 to 2

**Figure 9-1. Block Diagram of TMM0**

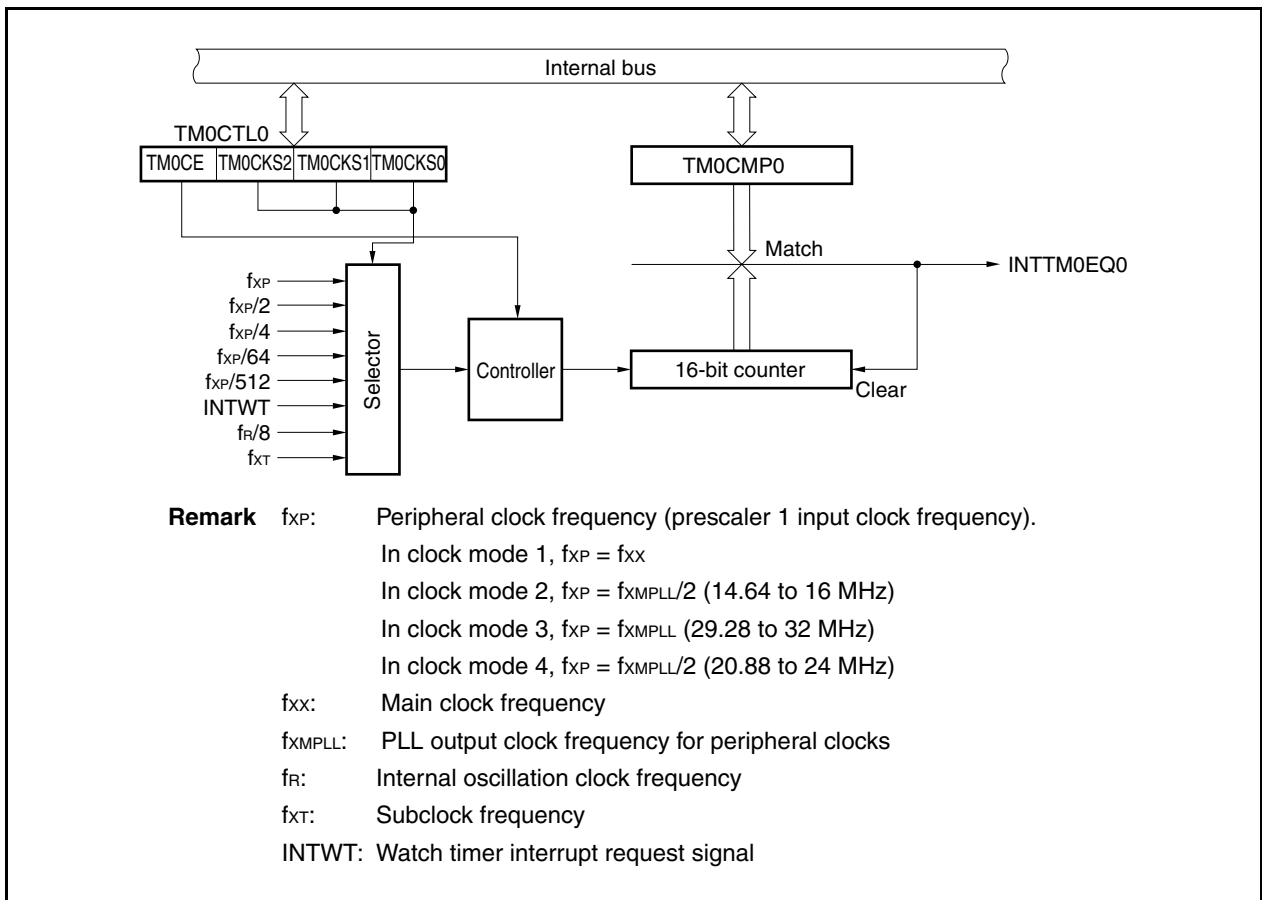
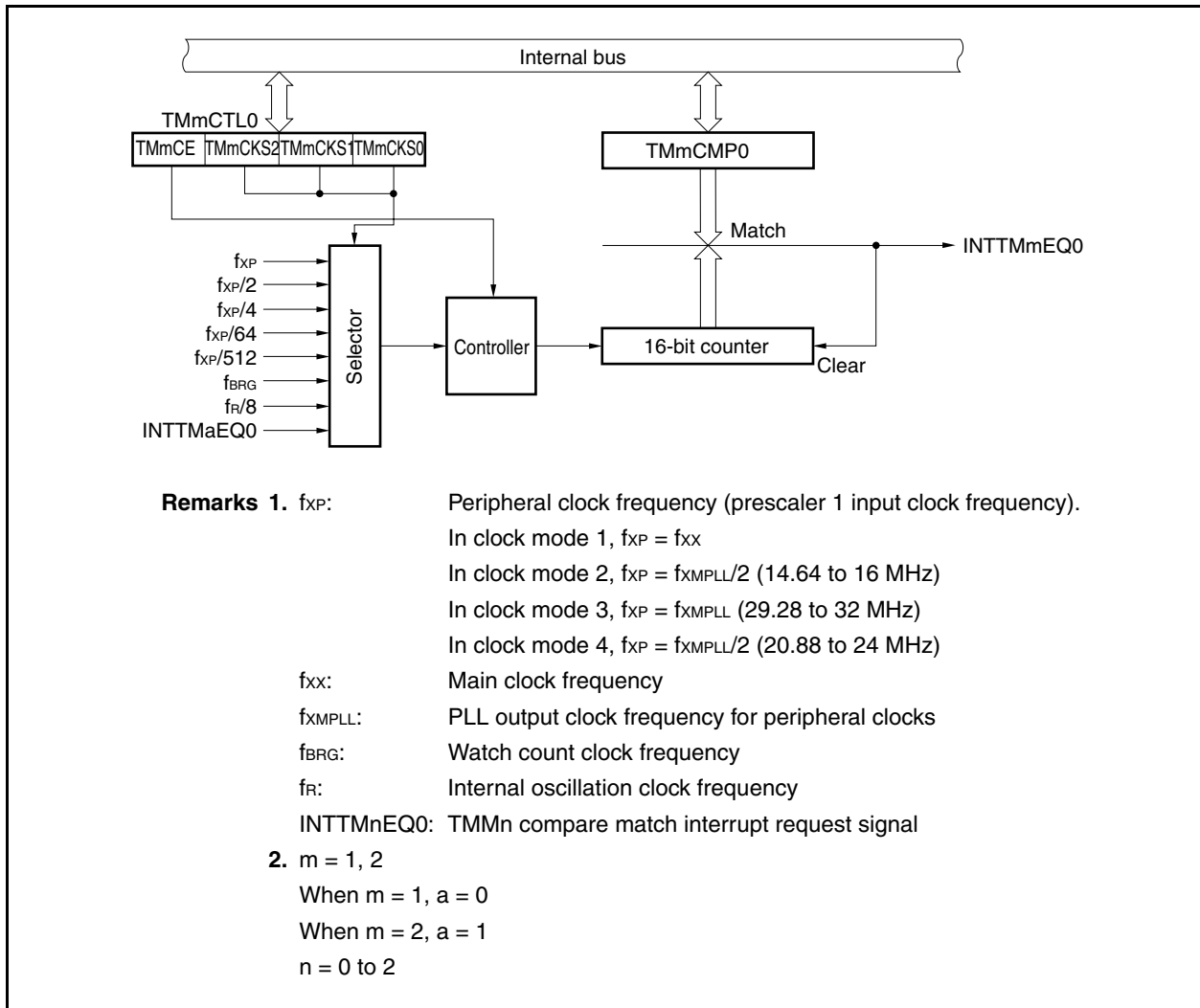

Figure 9-2. Block Diagram of TMM1 and TMM2



**(1) 16-bit counter**

This is a 16-bit counter that counts the internal clock.  
 The 16-bit counter cannot be read or written.

**(2) TMMn compare register 0 (TMnCMP0)**

The TMnCMP0 register is a 16-bit compare register.  
 This register can be read or written in 16-bit units.  
 Reset sets this register to 0000H.  
 The same value can always be written to the TMnCMP0 register by software.  
 During the TMMn operation (TMnCTL0.TMnCE bit = 1), rewriting the TMnCMP0 register is prohibited.

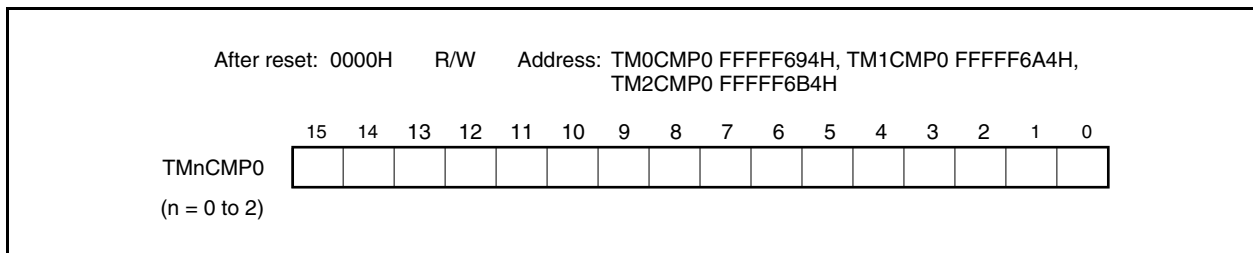



### 9.3 Register

#### (1) TMMn control register 0 (TMnCTL0)

The TMnCTL0 register is an 8-bit register that controls the TMMn operation.

This register can be read or written in 8-bit or 1-bit units.

Reset sets this register to 00H.

The same value can always be written to the TMnCTL0 register by software.

After reset: 00H	R/W	Address: TMOCTL0 FFFF690H, TM1CTL0 FFFF6A0H TM2CTL0 FFFF6B0H						
TMnCTL0 (n = 0 to 2)	<7>	6	5	4	3	2	1	0
	TMnCE	0	0	0	0	TMnCKS2	TMnCKS1	TMnCKS0

TMnCE	Internal clock operation enable/disable specification
0	TMMn operation disabled (16-bit counter reset asynchronously). Operation clock application stopped.
1	TMMn operation enabled. Operation clock application started. TMMn operation started.
The internal clock control and internal circuit reset for TMMn are performed asynchronously with the TMnCE bit. When the TMnCE bit is cleared to 0, the internal clock of TMMn is disabled (fixed to low level) and 16-bit counter is reset asynchronously.	

TMnCKS2	TMnCKS1	TMnCKS0	Count clock selection		
			TMM0	TMM1	TMM2
0	0	0	f <sub>XP</sub>	f <sub>XP</sub>	f <sub>XP</sub>
0	0	1	f <sub>XP</sub> /2	f <sub>XP</sub> /2	f <sub>XP</sub> /2
0	1	0	f <sub>XP</sub> /4	f <sub>XP</sub> /4	f <sub>XP</sub> /4
0	1	1	f <sub>XP</sub> /64	f <sub>XP</sub> /64	f <sub>XP</sub> /64
1	0	0	f <sub>XP</sub> /512	f <sub>XP</sub> /512	f <sub>XP</sub> /512
1	0	1	INTWT	f <sub>BRG</sub>	f <sub>BRG</sub>
1	1	0	f <sub>R</sub> /8	f <sub>R</sub> /8	f <sub>R</sub> /8
1	1	1	f <sub>XT</sub>	INTTM0EQ0	INTTM1EQ0

**Cautions**

1. Set the TMnCKS2 to TMnCKS0 bits when TMnCE bit = 0. When changing the value of TMnCE from 0 to 1, it is not possible to set the value of the TMnCKS2 to TMnCKS0 bits simultaneously.
2. Be sure to clear bits 3 to 6 to "0".

**Remarks**

1. f<sub>XP</sub>: Peripheral clock frequency (prescaler 1 input clock frequency).  
 In clock mode 1, f<sub>XP</sub> = f<sub>XX</sub>  
 In clock mode 2, f<sub>XP</sub> = f<sub>XMPLL</sub>/2 (14.64 to 16 MHz)  
 In clock mode 3, f<sub>XP</sub> = f<sub>XMPLL</sub> (29.28 to 32 MHz)  
 In clock mode 4, f<sub>XP</sub> = f<sub>XMPLL</sub>/2 (20.88 to 24 MHz)
- f<sub>XX</sub>: Main clock frequency
- f<sub>XMPLL</sub>: PLL output clock frequency for peripheral clocks
- f<sub>BRG</sub>: Watch count clock frequency
- f<sub>R</sub>: Internal oscillation clock frequency
- f<sub>XT</sub>: Subclock frequency
- INTTMaEQ0: TMMa compare match interrupt request signal

2. a = 0, 1

## 9.4 Operation

**Caution** Do not set the TMnCMP0 register to FFFFH.

### 9.4.1 Interval timer mode

In the interval timer mode, an interrupt request signal (INTTMnEQ0) is generated at the specified interval by the TMnCMP0 register if the TMnCTL0.TMnCE bit is set to 1.

**Figure 9-3. Configuration of Interval Timer**

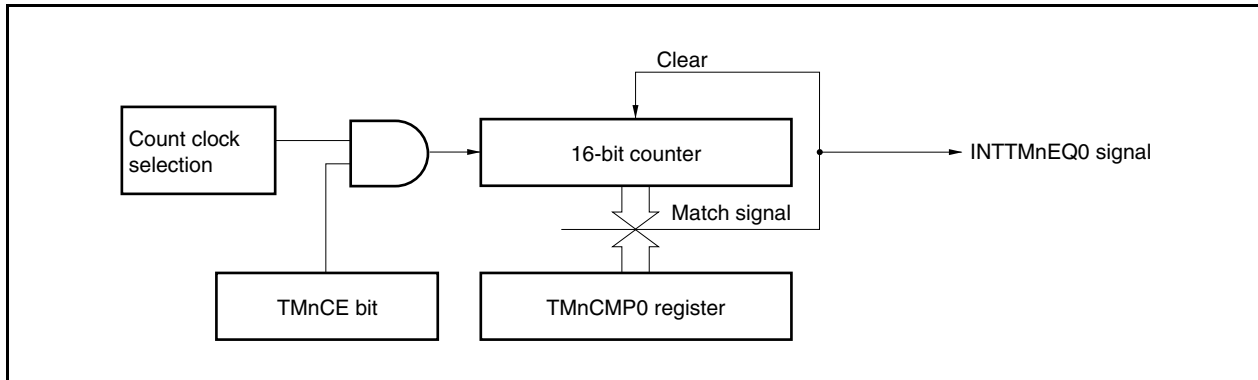

**Figure 9-4. Basic Timing of Operation in Interval Timer Mode**

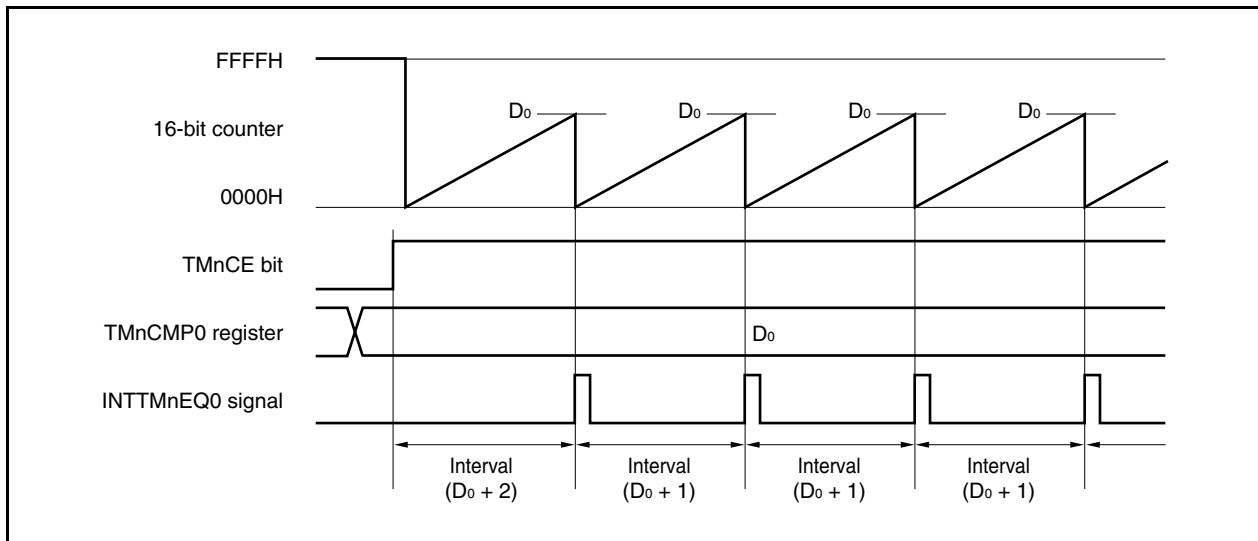

When the TMnCE bit is set to 1, the value of the 16-bit counter is cleared from FFFFH to 0000H in synchronization with the count clock, and the counter starts counting.

When the count value of the 16-bit counter matches the value of the TMnCMP0 register, the 16-bit counter is cleared to 0000H and a compare match interrupt request signal (INTTMnEQ0) is generated.

The interval can be calculated by the following expression.

$$\text{Interval} = (\text{Set value of TMnCMP0 register} + 1) \times \text{Count clock cycle}$$

Figure 9-5. Register Setting for Interval Timer Mode Operation

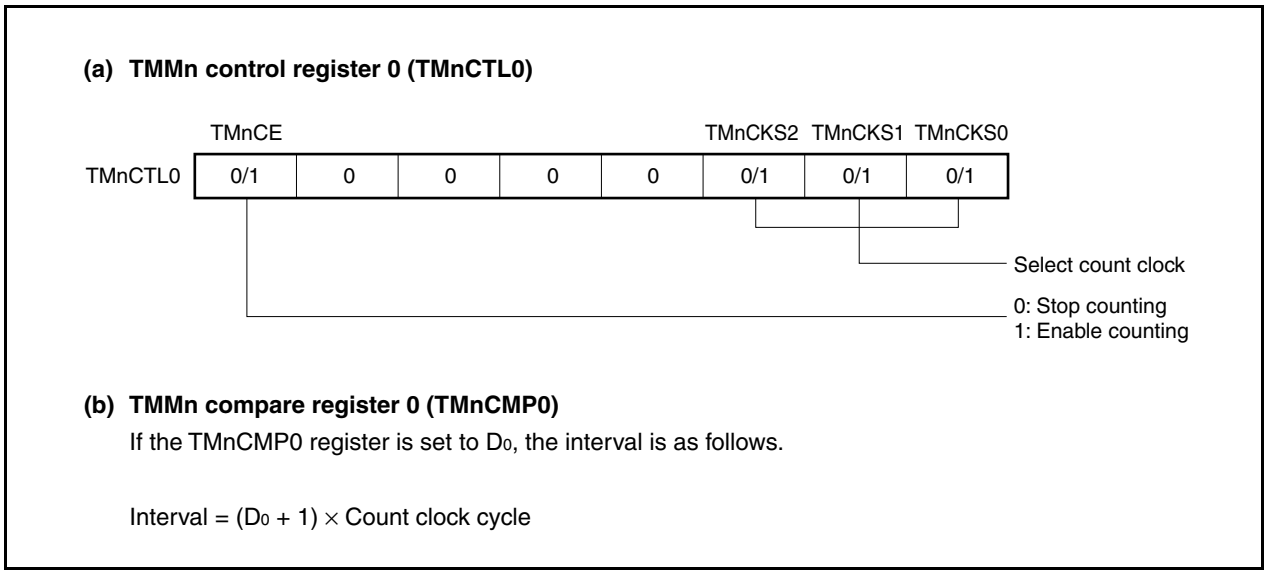

(1) Interval timer mode operation flow

Figure 9-6. Software Processing Flow in Interval Timer Mode

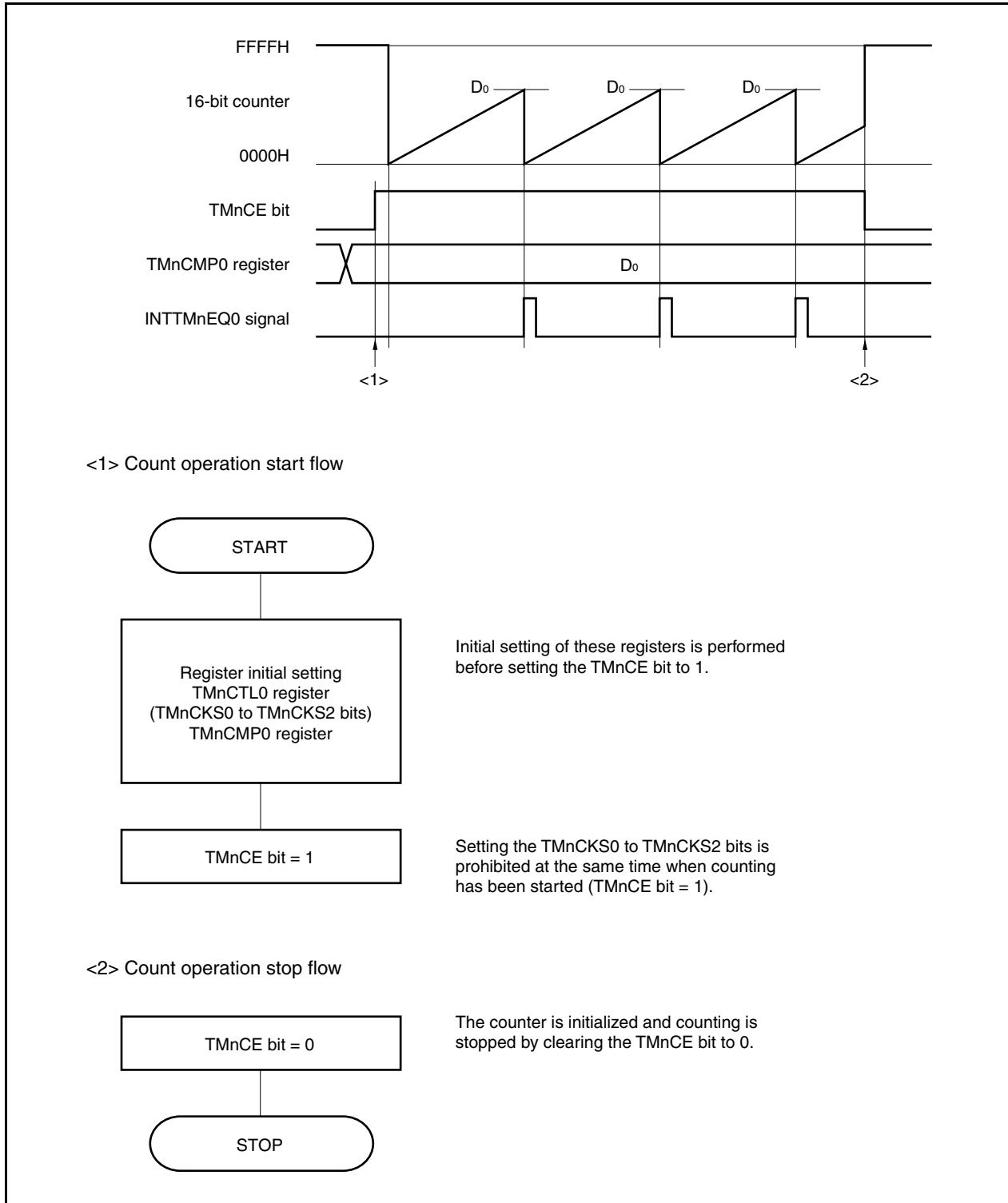

(2) Interval timer mode operation timing

**Caution** Do not set the TMnCMP0 register to FFFFH.

(a) Operation if TMnCMP0 register is set to 0000H

If the TMnCMP0 register is set to 0000H, the INTTMnEQ0 signal is generated at each count clock. The value of the 16-bit counter is always 0000H.

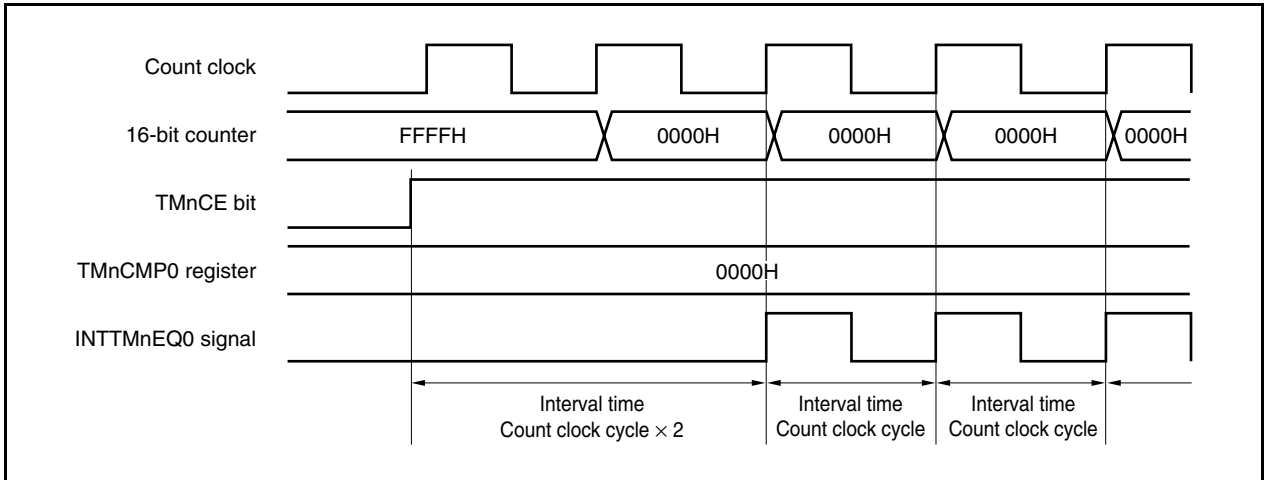

(b) Operation if TMnCMP0 register is set to N

If the TMnCMP0 register is set to N, the 16-bit counter counts up to N. The counter is cleared to 0000H in synchronization with the next count-up timing and the INTTMnEQ0 signal is generated.

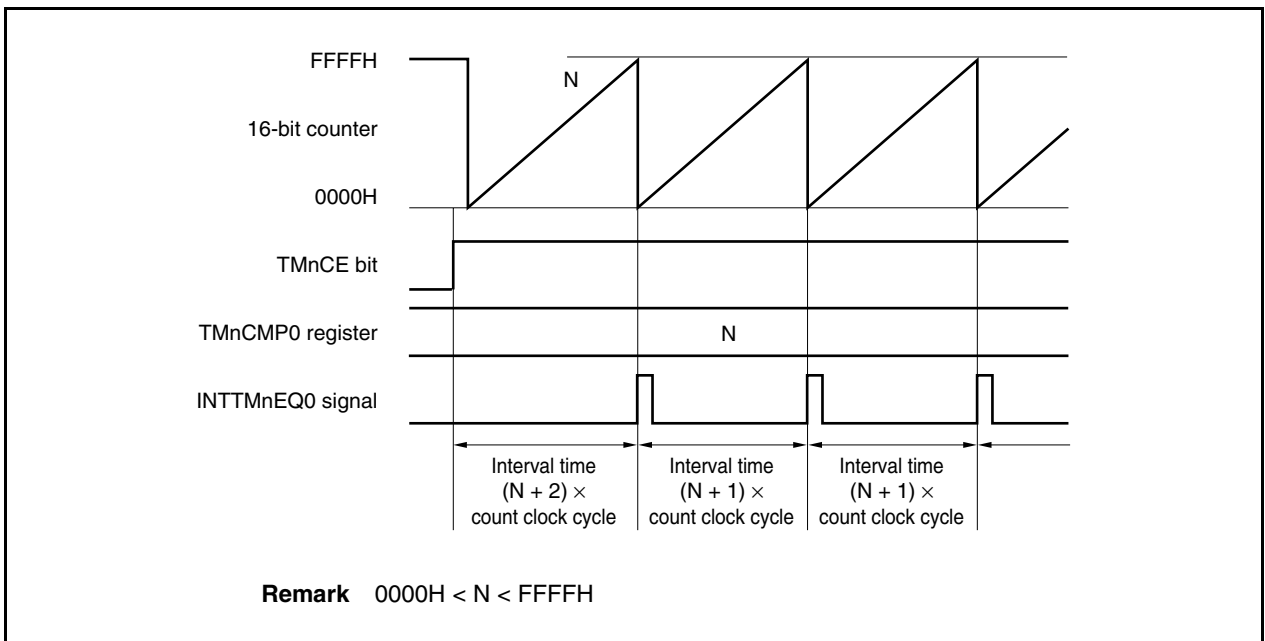

## 9.4.2 Cautions

### (1) Maximum time before counting start

It takes the 16-bit counter up to the following time to start counting after the TMnCTL0.TMnCE bit is set to 1, depending on the count clock selected.

Selected Count Clock	Maximum Time Before Counting Start
$f_{XP}$	$2/f_{XP}$
$f_{XP}/2$	$3/f_{XP}$
$f_{XP}/4$	$6/f_{XP}$
$f_{XP}/64$	$128/f_{XP}$
$f_{XP}/512$	$1024/f_{XP}$
INTWT	Second rising edge of INTWT signal
$f_R/8$	$16/f_R$
$f_{XT}$	$2/f_{XT}$
$f_{BRG}$	$2/f_{BRG}$
INTTM0EQ0	Second rising edge of INTTM0EQ0 signal
INTTM1EQ0	Second rising edge of INTTM1EQ0 signal

**Remarks 1.**  $f_{XP}$ : Peripheral clock frequency (prescaler 1 input clock frequency).

In clock mode 1,  $f_{XP} = f_{XX}$

In clock mode 2,  $f_{XP} = f_{XMPLL}/2$  (14.64 to 16 MHz)

In clock mode 3,  $f_{XP} = f_{XMPLL}$  (29.28 to 32 MHz)

In clock mode 4,  $f_{XP} = f_{XMPLL}/2$  (20.88 to 24 MHz)

$f_{XX}$ : Main clock frequency

$f_{XMPLL}$ : PLL output clock frequency for peripheral clocks

$f_{BRG}$ : Watch count clock frequency

$f_R$ : Internal oscillation clock frequency

$f_{XT}$ : Subclock frequency

INTTMaEQ0: TMMa compare match interrupt request signal

2. a = 0, 1

### (2) Caution on setting the TMnCMP0 and TMnCTL0 registers

Rewriting the TMnCMP0 and TMnCTL0 registers is prohibited while TMMn is operating.

If these registers are rewritten while the TMnCE bit is 1, the operation cannot be guaranteed.

If they are rewritten by mistake, clear the TMnCTL0.TMnCE bit to 0, and re-set the registers.

### (3) Caution for the interval timer mode

Do not set the TMnCMP0 register to FFFFH.

### (4) Switching DMA transfer start factor

In the V850E/SJ3-H and V850E/SK3-H, the INTTM1EQ0 and INTKR signals and the INTTM2EQ0 and INTP8 signals, which are the DMA transfer start factors, respectively share the same pin, and they cannot be used at the same time. To use INTTM1EQ0 or INTTM2EQ0 signal as the DAM transfer start factor, set the DTFROB0 bit of the option byte 0000007AH to 1. (Refer to **CHAPTER 33 OPTION BYTE FUNCTION.**) In this case, the INTKR and INTP8 signals cannot be used as the DMA transfer start factor.

**Remark** For details, see **Table 22-1 DMA Transfer Start Factors.**

## CHAPTER 10 WATCH FUNCTIONS

This chapter explains prescaler 3, watch timer, and real-time counter (RTC). For timer M, refer to **CHAPTER 9 16-BIT INTERVAL TIMER M (TMM)**.

### 10.1 Overview

The V850E/SJ3-H and V850E/SK3-H realizes a watch function in the following four ways.

#### (1) Watch timer

This timer generates an interrupt request signal (INTWT) at an interval of 0.5 or 0.25 seconds by using the main oscillation clock (fx) or subclock (fx<sub>T</sub>). When the main oscillation clock (fx) is used as the count clock, its frequency is divided by a prescaler 3 to 32.768 kHz.

#### (2) Watch timer + timer M0 (TMM0)

The main oscillation clock (fx) is divided by prescaler 3, watch timer, and TMM0 and an interrupt request signal (INTTMM0EQ0) is generated at an interval of 0.5 or 0.25 seconds. The frequency of 32.768 kHz is not necessary, and the watch function can be realized by using the main oscillation clock (fx) of any frequency.

#### (3) Real-time counter (RTC)

This counter can count up to 99 years, having a year, month, week, day, hour, minute, and second counters and a subcounter. The count value of the year, month, week, day, hour, minute, and second counters is indicated in BCD code<sup>Note</sup>. In addition, an alarm interrupt signal (INTRTC1) that generates an interrupt at any week, hour, and minute, and a periodic interrupt signal (INTRTC0) of 1 month to 0.5 seconds are supported. As the count clock, the main oscillation clock (fx) or subclock (fx<sub>T</sub>) can be used. When the main oscillation clock (fx) is used as the count clock, its frequency is divided by prescaler 3 to 32.768 kHz.

#### (4) Timer M1 or timer M2 (TMM1 or TMM2)

The main oscillation clock (fx) is divided by prescaler 3 and TMM1 or TMM2 and an interrupt request signal (INTTMMnEQ0) is generated at a time interval of 0.5 or 0.25 seconds. The frequency of 32.768 kHz is not necessary, and the watch function can be realized by the main oscillation clock (fx) of any frequency.

**Note** BCD (Binary Coded Decimal) code expresses the value of each digit of a decimal number in 4-bit binary number.

- Remarks**
- (1) and (2) above are compatible with the V850ES/SG3 and V850ES/SJ3.
  - When the main oscillation clock (fx) is used as the count clock, the IDLE2 mode is used as the standby mode to lower the current consumption. In the IDLE2 mode, the main oscillation clock (fx) continues, so that the watch function can continue even in the standby mode.
  - n = 1 or 2

## 10.2 Configuration

The block diagram of the watch function is shown below.

Figure 10-1. Block Diagram of Watch Function

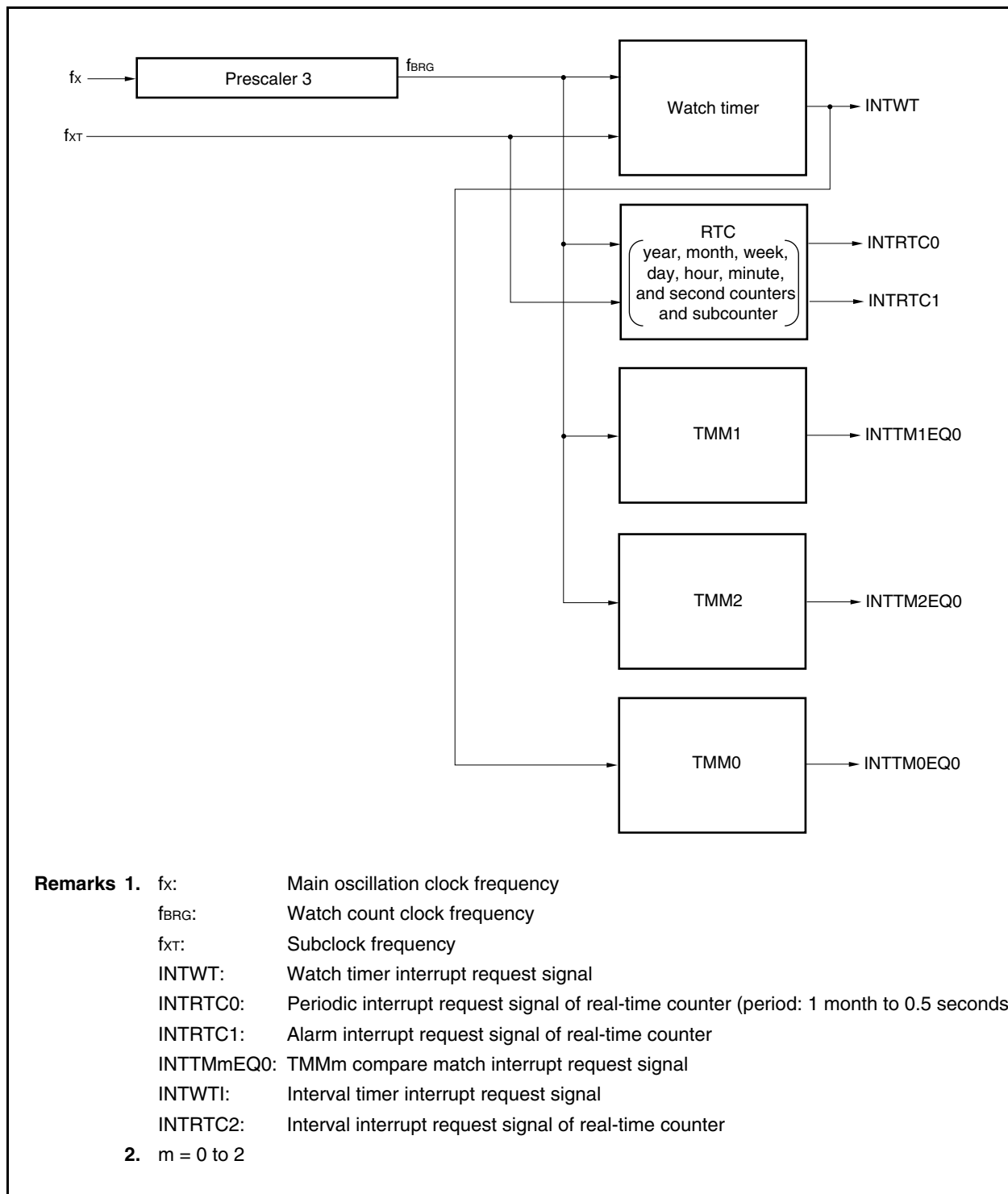



### 10.3 Prescaler 3

#### 10.3.1 Function

This prescaler generates a count clock (32.768 kHz) of the watch timer or real-time counter by dividing the main oscillation clock ( $f_x$ ).

It is also used in combination with TMM1 or TMM2, or with the watch timer and TMM0 to generate an interrupt request signal (INTTMMEQ0) of a time interval of 0.5 to 0.25 seconds which is necessary for the watch function, from the main oscillation clock ( $f_x$ ) of any frequency ( $m = 0$  to 2).

#### 10.3.2 Configuration

The block diagram of prescaler 3 is shown below.

Figure 10-2. Block Diagram of Prescaler 3

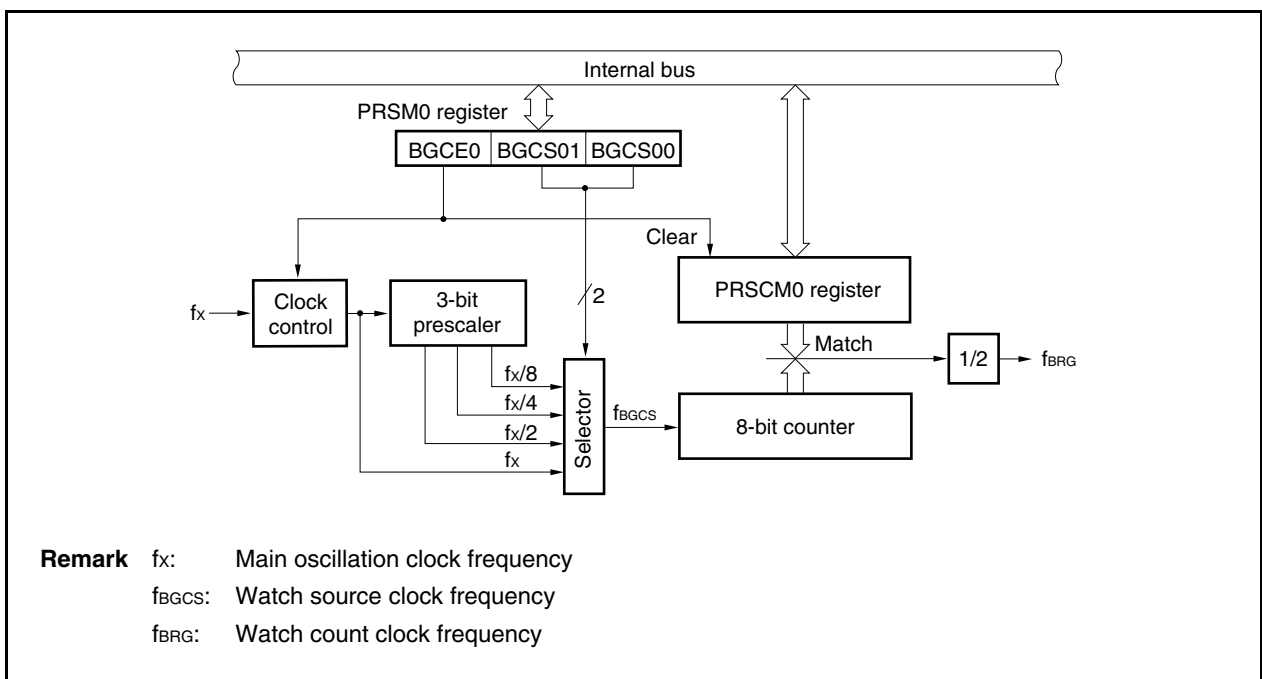

**(1) Clock control**

This circuit controls supplying and stopping of the main oscillation clock ( $f_x$ ).

**(2) 3-bit prescaler**

This is a prescaler that divides  $f_x$  and generates  $f_x/2$ ,  $f_x/4$ , or  $f_x/8$ .

**(3) 8-bit counter**

This is an 8-bit counter that counts the watch source clock ( $f_{BGCS}$ ).

**(4) PRSCM0 register**

This is an 8-bit compare register that sets the interval time of  $f_{BRG}$ .

**(5) PRSM0 register**

This register is used to control clock supply to the watch timer and select a watch source clock ( $f_{BGCS}$ ).

### 10.3.3 Registers

The following registers are provided for the prescaler 3.

- Prescaler mode register 0 (PRSM0)
- Prescaler compare register 0 (PRSCM0)

#### (1) Prescaler mode register 0 (PRSM0)

The PRSM0 register controls the generation of the watch timer count clock.

This register can be read or written in 8-bit or 1-bit units.

Reset sets this register to 00H.

After reset: 00H    R/W    Address: FFFFF8B0H								
	7	6	5	<4>	3	2	1	0
PRSM0	0	0	0	BGCE0	0	0	BGCS01	BGCS00

BGCE0	Main clock operation enable
0	Disabled
1	Enabled

BGCS01	BGCS00	Selection of watch source clock ( $f_{BGCS}$ )		5 MHz	4 MHz
0	0	$f_x$	200 ns	250 ns	
0	1	$f_x/2$	400 ns	500 ns	
1	0	$f_x/4$	800 ns	1 $\mu$ s	
1	1	$f_x/8$	1.6 $\mu$ s	2 $\mu$ s	

**Cautions**

1. Do not change the values of the BGCS00 and BGCS01 bits during watch timer operation.
2. Set the PRSM0 register before setting the BGCE0 bit to 1.
3. To realize the watch function by the watch timer or the real-time counter (RTC), set the PRSM0 and PRSCM0 registers according to the main oscillation clock frequency ( $f_x$ ) to be used so as to obtain an  $f_{BRG}$  frequency of 32.768 kHz.
4. Be sure to set bits 2, 3, and 5 to 7 to "0".

**(2) Prescaler compare register 0 (PRSCM0)**

The PRSCM0 register is an 8-bit compare register.

This register can be read or written in 8-bit units.

Reset sets this register to 00H.

After reset: 00H    R/W    Address: FFFF8B1H

PRSCM0	7	6	5	4	3	2	1	0
	PRSCM07	PRSCM06	PRSCM05	PRSCM04	PRSCM03	PRSCM02	PRSCM01	PRSCM00

**Cautions**

- 1. Do not rewrite the PRSCM0 register during watch timer operation.**
- 2. Set the PRSCM0 register before setting the PRSM0.BGCE0 bit to 1.**
- 3. To realize the watch function by the watch timer or the real-time counter (RTC), set the PRSM0 and PRSCM0 registers according to the main oscillation clock frequency (fx) to be used so as to obtain an fBRG frequency of 32.768 kHz.**

The calculation for fBRG is shown below.

$$f_{BRG} = f_{BGCS} / 2N$$

**Remark** fBGCS: Watch source clock set by the PRSM0 register  
 N: Set value of PRSCM0 register = 1 to 256  
 However, N = 256 only when PRSCM0 register is set to 00H.

**Example** When  $f_x = 3.997696$  MHz  
 $N = 61$  (Set value of PRSCM0 register = 3DH)  
 $f_{BGCS} = f_x = 3.997696$  MHz (Set value of PRSM0 register = 10H)  
 $f_{BRG} = 3.997696 / (2 \times 61)$   
 $= 32.768$  [kHz]

## 10.4 Watch Timer Functions

### 10.4.1 Functions

The watch timer has the following functions.

- Watch timer: An interrupt request signal (INTWT) is generated at intervals of 0.5 or 0.25 seconds by using the main oscillation clock (fx) or subclock (fxT).
- Interval timer: An interrupt request signal (INTWTI) is generated at set intervals.

The watch timer and interval timer functions can be used at the same time.

### 10.4.2 Configuration

The block diagram of the watch timer is shown below.

Figure 10-3. Block Diagram of Watch Timer

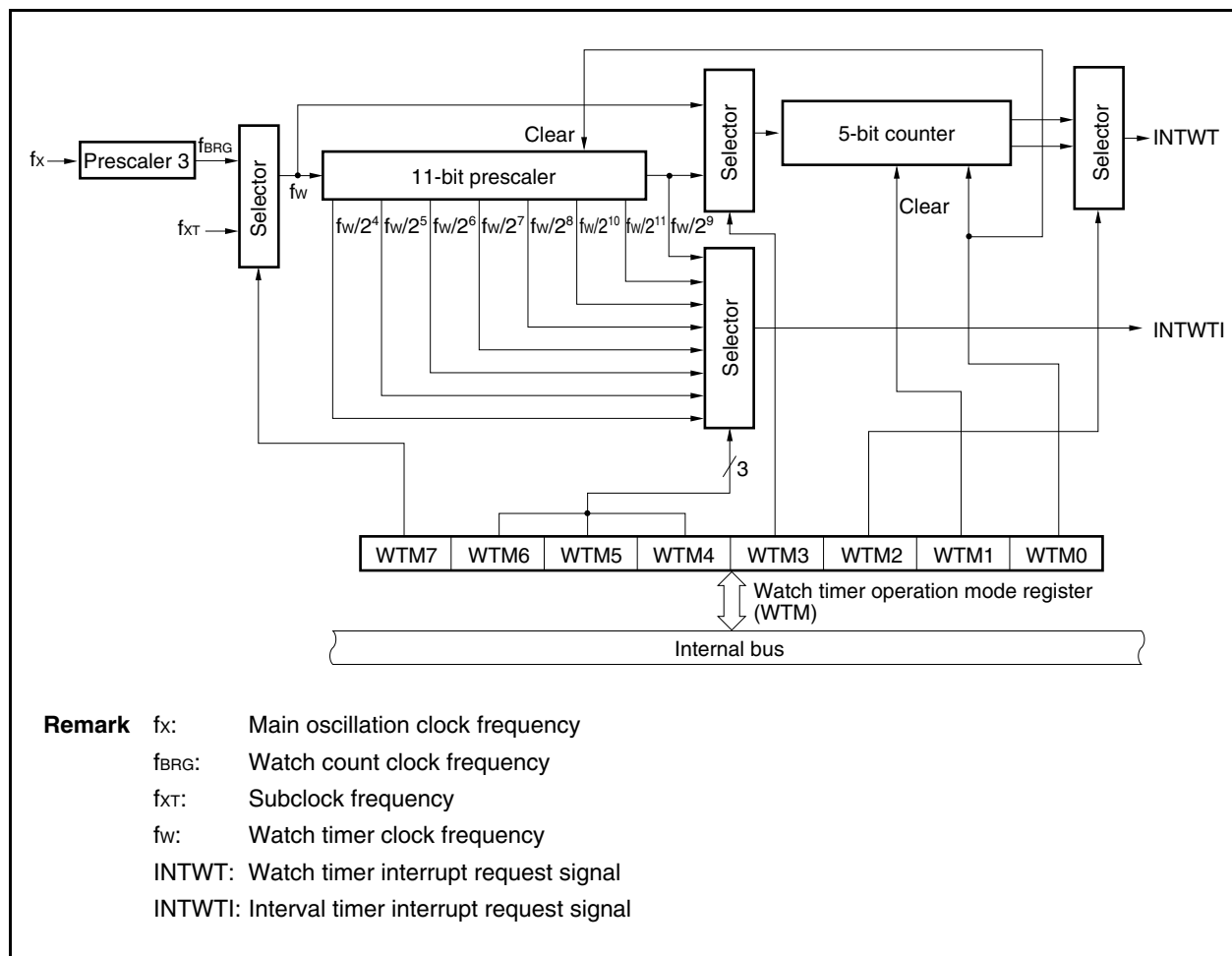

**(1) 11-bit prescaler**

This prescaler divides  $f_w$  to generate a clock of  $f_w/2^4$  to  $f_w/2^{11}$ .

**(2) 5-bit counter**

This counter counts  $f_w$  or  $f_w/2^9$ , and generates a watch timer interrupt request signal at intervals of  $2^4/f_w$ ,  $2^5/f_w$ ,  $2^{13}/f_w$ , or  $2^{14}/f_w$ .

**(3) Selector**

The watch timer has the following four selectors.

- Selector that selects the main oscillation clock ( $f_x$ ) or subclock ( $f_{XT}$ ) as the clock of the watch timer
- Selector that selects  $f_w$  or  $f_w/2^9$  as the count clock frequency of the 5-bit counter
- Selector that selects  $2^4/f_w$ ,  $2^{13}/f_w$ ,  $2^5/f_w$ , or  $2^{14}/f_w$  as the INTWT signal generation time interval
- Selector that selects  $2^4/f_w$  to  $2^{11}/f_w$  as the interval timer interrupt request signal (INTWTI) generation time interval

**(4) WTM register**

This is an 8-bit register that controls the operation of the watch timer/interval timer, and sets the interrupt request signal generation interval.

### 10.4.3 Control Registers

The following registers are provided for the watch timer.

- Watch timer operation mode register (WTM)
- Prescaler mode register 0 (PRSM0)
- Prescaler compare register 0 (PRSCM0)

#### (1) Watch timer operation mode register (WTM)

The WTM register enables or disables the count clock and operation of the watch timer, sets the interval time of the prescaler, controls the operation of the 5-bit counter, and sets the set time of the watch flag.

Set the PRSM0 register before setting the WTM register.

This register can be read or written in 8-bit or 1-bit units.

Reset sets this register to 00H.

(1/2)

After reset: 00H								R/W	Address: FFFFF680H								
			7	6	5	4	3	2	<1>	<0>							
WTM			WTM7	WTM6	WTM5	WTM4	WTM3	WTM2	WTM1	WTM0							
			WTM7	WTM6	WTM5	WTM4	Selection of interval time of prescaler										
			0	0	0	0	$2^4/f_w$ (488 $\mu$ s: $f_w = f_{XT}$ )										
			0	0	0	1	$2^5/f_w$ (977 $\mu$ s: $f_w = f_{XT}$ )										
			0	0	1	0	$2^6/f_w$ (1.95 ms: $f_w = f_{XT}$ )										
			0	0	1	1	$2^7/f_w$ (3.91 ms: $f_w = f_{XT}$ )										
			0	1	0	0	$2^8/f_w$ (7.81 ms: $f_w = f_{XT}$ )										
			0	1	0	1	$2^9/f_w$ (15.6 ms: $f_w = f_{XT}$ )										
			0	1	1	0	$2^{10}/f_w$ (31.3 ms: $f_w = f_{XT}$ )										
			0	1	1	1	$2^{11}/f_w$ (62.5 ms: $f_w = f_{XT}$ )										
			1	0	0	0	$2^4/f_w$ (488 $\mu$ s: $f_w = f_{BRG}$ )										
			1	0	0	1	$2^5/f_w$ (977 $\mu$ s: $f_w = f_{BRG}$ )										
			1	0	1	0	$2^6/f_w$ (1.95 ms: $f_w = f_{BRG}$ )										
			1	0	1	1	$2^7/f_w$ (3.91 ms: $f_w = f_{BRG}$ )										
			1	1	0	0	$2^8/f_w$ (7.81 ms: $f_w = f_{BRG}$ )										
			1	1	0	1	$2^9/f_w$ (15.6 ms: $f_w = f_{BRG}$ )										
			1	1	1	0	$2^{10}/f_w$ (31.3 ms: $f_w = f_{BRG}$ )										
			1	1	1	1	$2^{11}/f_w$ (62.5 ms: $f_w = f_{BRG}$ )										

WTM7	WTM3	WTM2	Selection of set time of watch flag
0	0	0	$2^{14}/f_w$ (0.5 s: $f_w = f_{XT}$ )
0	0	1	$2^{13}/f_w$ (0.25 s: $f_w = f_{XT}$ )
0	1	0	$2^5/f_w$ (977 $\mu$ s: $f_w = f_{XT}$ )
0	1	1	$2^4/f_w$ (488 $\mu$ s: $f_w = f_{XT}$ )
1	0	0	$2^{14}/f_w$ (0.5 s: $f_w = f_{BRG}$ )
1	0	1	$2^{13}/f_w$ (0.25 s: $f_w = f_{BRG}$ )
1	1	0	$2^5/f_w$ (977 $\mu$ s: $f_w = f_{BRG}$ )
1	1	1	$2^4/f_w$ (488 $\mu$ s: $f_w = f_{BRG}$ )

WTM1	Control of 5-bit counter operation
0	Clears after operation stops
1	Starts

WTM0	Watch timer operation enable
0	Stops operation (clears both prescaler and 5-bit counter)
1	Enables operation

**Caution** Rewrite the WTM2 to WTM7 bits while both the WTM0 and WTM1 bits are 0.

- Remarks**
1.  $f_w$ : Watch timer clock frequency
  2. Values in parentheses apply to operation with  $f_w = 32.768$  kHz

**(2) Prescaler mode register 0 (PRSM0)**

For details, refer to 10.3.3 (1) Prescaler mode register 0 (PRSM0).

**(3) Prescaler compare register 0 (PRSCM0)**

For details, refer to 10.3.3 (2) Prescaler compare register 0 (PRSCM0).

## 10.4.4 Operation

## (1) Operation as watch timer

The watch timer generates an interrupt request signal (INTWT) at fixed time intervals. The watch timer operates using time intervals of 0.25 or 0.5 seconds with the subclock ( $f_{XT}$ ) (32.768 kHz) or main oscillation clock ( $f_x$ ).

The count operation starts when the WTM.WTM1 and WTM.WTM0 bits are set to 11. When the WTM0 bit is cleared to 0, the 11-bit prescaler and 5-bit counter are cleared and the count operation stops.

The time of the watch timer can be adjusted by clearing the WTM1 bit to 0 and then the 5-bit counter when operating at the same time as the interval timer. At this time, an error of up to 15.6 ms may occur for the watch timer, but the interval timer is not affected.

If the main oscillation clock ( $f_x$ ) is used as the count clock of the watch timer, set the count clock using the PRSM0.BGCS01 and BGCS00 bits, the 8-bit comparison value using the PRSCM0 register, and the count clock frequency ( $f_{BRG}$ ) of the watch timer to 32.768 kHz.

When the PRSM0.BGCE0 bit is set (1),  $f_{BRG}$  is supplied to the watch timer.

## (2) Operation as interval timer

The watch timer can also be used as an interval timer that repeatedly generates an interrupt request signal (INTWTI) at intervals specified by a preset count value.

The interval time can be selected by the WTM.WTM4 to WTM7 bits.

Table 10-1. Interval Time of Interval Timer

WTM7	WTM6	WTM5	WTM4	Interval Time	
0	0	0	0	$2^4 \times 1/f_w$	488 $\mu$ s (operating at $f_w = f_{XT} = 32.768$ kHz)
0	0	0	1	$2^5 \times 1/f_w$	977 $\mu$ s (operating at $f_w = f_{XT} = 32.768$ kHz)
0	0	1	0	$2^6 \times 1/f_w$	1.95 ms (operating at $f_w = f_{XT} = 32.768$ kHz)
0	0	1	1	$2^7 \times 1/f_w$	3.91 ms (operating at $f_w = f_{XT} = 32.768$ kHz)
0	1	0	0	$2^8 \times 1/f_w$	7.81 ms (operating at $f_w = f_{XT} = 32.768$ kHz)
0	1	0	1	$2^9 \times 1/f_w$	15.6 ms (operating at $f_w = f_{XT} = 32.768$ kHz)
0	1	1	0	$2^{10} \times 1/f_w$	31.3 ms (operating at $f_w = f_{XT} = 32.768$ kHz)
0	1	1	1	$2^{11} \times 1/f_w$	62.5 ms (operating at $f_w = f_{XT} = 32.768$ kHz)
1	0	0	0	$2^4 \times 1/f_w$	488 $\mu$ s (operating at $f_w = f_{BRG} = 32.768$ kHz)
1	0	0	1	$2^5 \times 1/f_w$	977 $\mu$ s (operating at $f_w = f_{BRG} = 32.768$ kHz)
1	0	1	0	$2^6 \times 1/f_w$	1.95 ms (operating at $f_w = f_{BRG} = 32.768$ kHz)
1	0	1	1	$2^7 \times 1/f_w$	3.91 ms (operating at $f_w = f_{BRG} = 32.768$ kHz)
1	1	0	0	$2^8 \times 1/f_w$	7.81 ms (operating at $f_w = f_{BRG} = 32.768$ kHz)
1	1	0	1	$2^9 \times 1/f_w$	15.6 ms (operating at $f_w = f_{BRG} = 32.768$ kHz)
1	1	1	0	$2^{10} \times 1/f_w$	31.3 ms (operating at $f_w = f_{BRG} = 32.768$ kHz)
1	1	1	1	$2^{11} \times 1/f_w$	62.5 ms (operating at $f_w = f_{BRG} = 32.768$ kHz)

**Remark**  $f_w$ : Watch timer clock frequency



Figure 10-4. Operation Timing of Watch Timer/Interval Timer

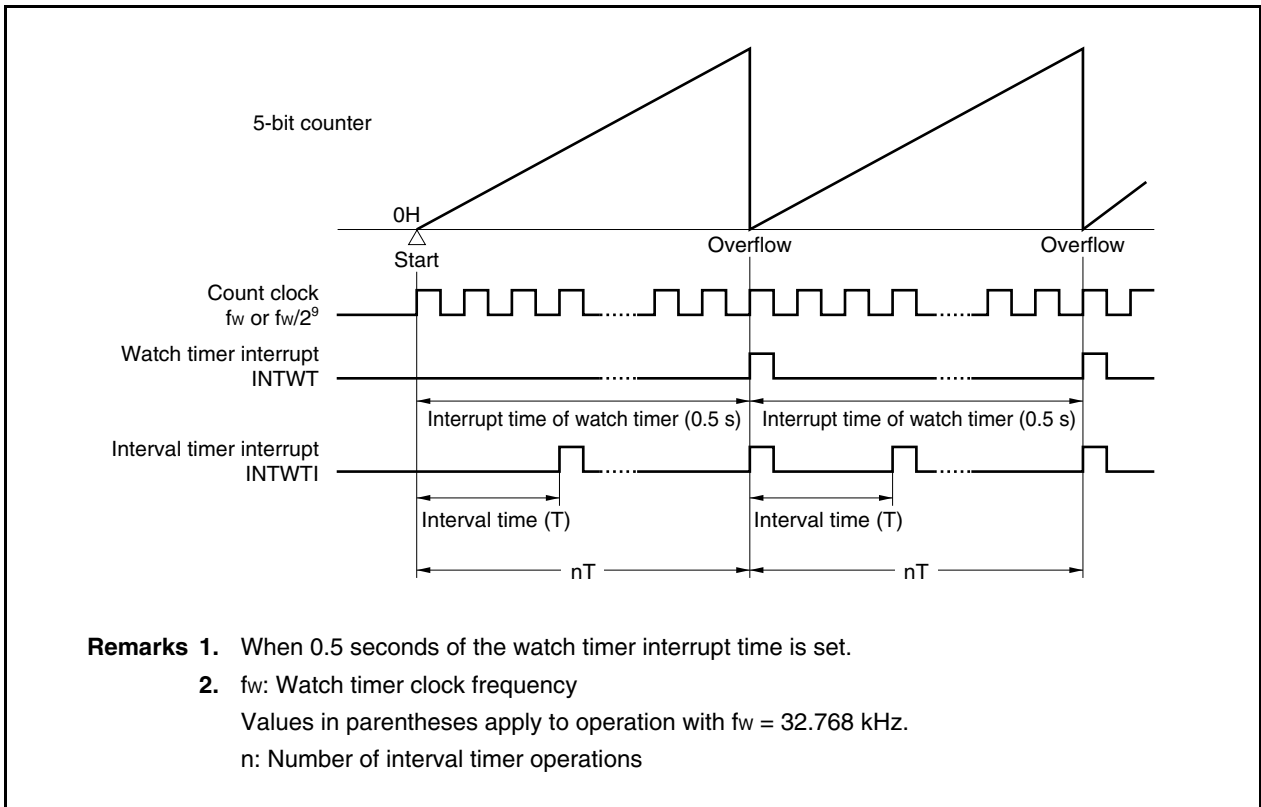

(3) Cautions

Some time is required before the first watch timer interrupt request signal (INTWT) is generated after operation is enabled (WTM.WTM1 and WTM.WTM0 bits = 1).

Figure 10-5. Example of Generation of Watch Timer Interrupt Request Signal (INTWT)  
(When Interrupt Cycle = 0.5 s)

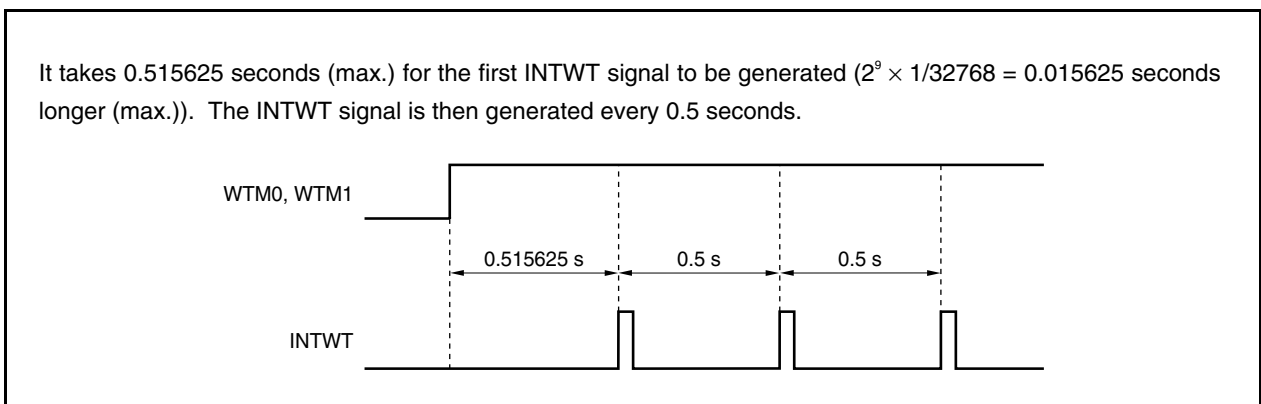

## 10.5 Real-time Counter (RTC)

### 10.5.1 Function

The real-time counter (RTC) has the following functions.

- Has year, month, week, day, hour, minute, and second counters and a subcounter, and can count up to 99 years.
- The value of the year, month, week, day, hour, minute, and second counters is indicated in BCD code<sup>Note 1</sup>.
- Alarm interrupt function
- Periodic interrupt function (period: 1 month to 0.5 s)
- Interval interrupt function (period: 1.95 ms to 125 ms)
- Pin output function of 1 Hz
- Pin output function of 32.768 kHz
- Pin output function of 512 Hz or 16.384 kHz
- Watch error correction function
- Subclock operation or main clock operation<sup>Note 2</sup> selectable

**Notes** 1. BCD (Binary Coded Decimal) code expresses the value of each digit of a decimal number as a 4-bit binary number.

2. Divide the main clock to 32.768 kHz by using the dedicated baud rate generator of the real-time counter.

### 10.5.2 Configuration

The real-time counter consists of the following hardware units.

**Table 10-2. Configuration of Real-Time Counter**

Item	Configuration
Control registers	Real-time counter control register 0 (RC1CC0) Real-time counter control register 1 (RC1CC1) Real-time counter control register 2 (RC1CC2) Real-time counter control register 3 (RC1CC3) Subcount register (RC1SUBC) Second count register (RC1SEC) Minute count register (RC1MIN) Hour count register (RC1HOUR) Day count register (RC1DAY) Week count register (RC1WEEK) Month count register (RC1MONTH) Year count register (RC1YEAR) Watch error correction register (RC1SUBU) Alarm minute setting register (RC1ALM) Alarm hour setting register (RC1ALH) Alarm week setting register (RC1ALW)

Figure 10-6. Block Diagram of Real-Time Counter

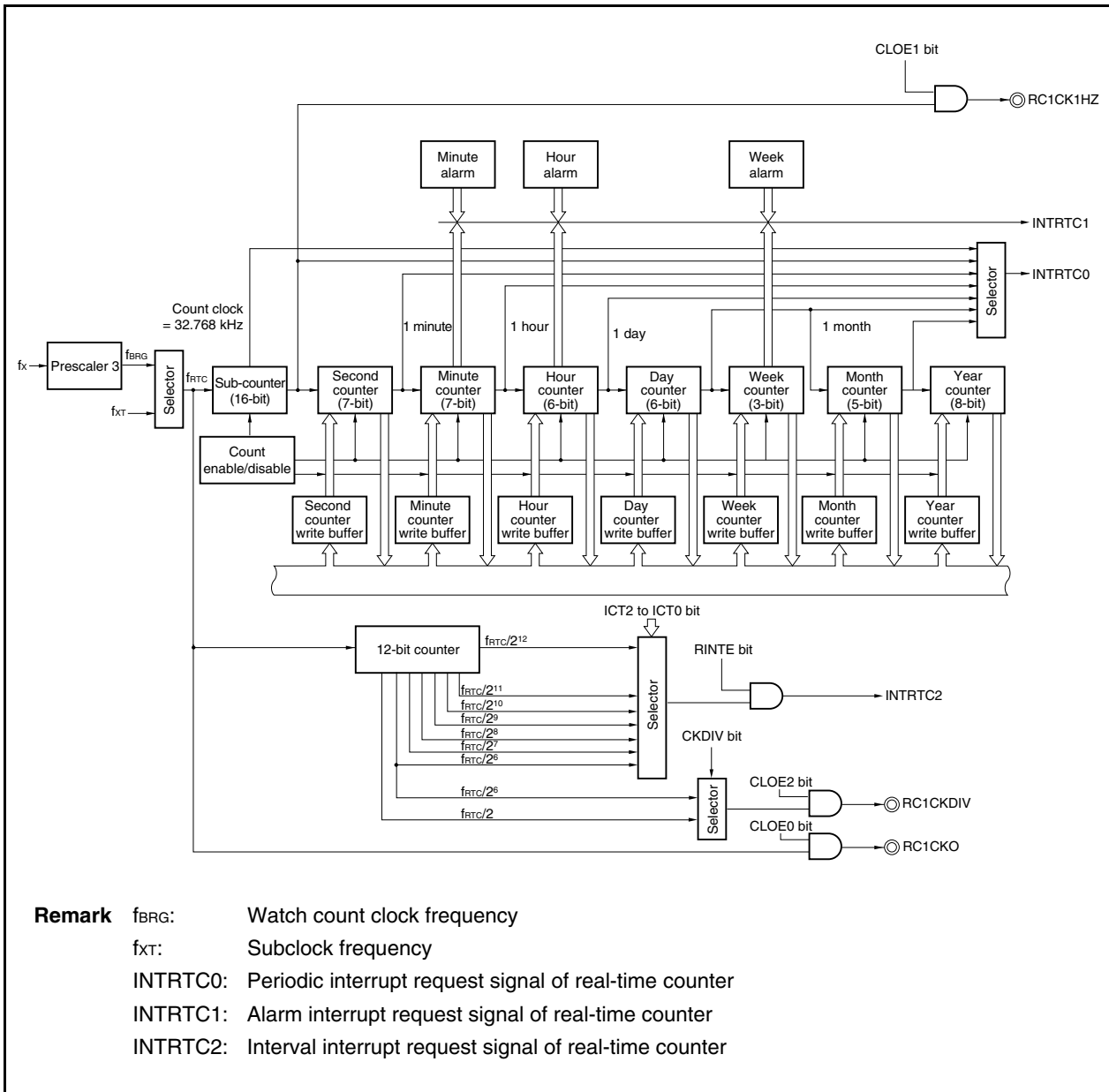

- Remark**
- $f_{BRG}$ : Watch count clock frequency
  - $f_{XT}$ : Subclock frequency
  - INTRTC0: Periodic interrupt request signal of real-time counter
  - INTRTC1: Alarm interrupt request signal of real-time counter
  - INTRTC2: Interval interrupt request signal of real-time counter

**(1) Pin configuration**

The RTC output pins constituting the real-time counter are alternate-function pins, as shown in **Table 10-3**. To use each of these pins, its port function must be set (refer to **Table 4-25 Using Port Pin as Alternate-Function Pin**).

**Table 10-3. Pin Configuration**

Pin No.		Port	RTC Output	Other Alternate Function
V850E/SJ3-H	V850E/SK3-H			
59	71	P80	RC1CK1HZ	RXDA3/INTP8
60	72	P81	RC1CKDIV	TXDA3/RC1CKO
60	72	P81	RC1CKO	TXDA3/RC1CKDIV

**(2) Interrupt function**

The RTC has the following three types of interrupt request signals.

**(a) INTRTC0**

This is a periodic interrupt request signal that is generated once every 0.5 second, 1 second, 1 minute, 1 hour, 1 day, or 1 month.

**(b) INTRTC1**

Alarm interrupt request signal

**(c) INTRTC2**

This is an interval interrupt request signal of a period of  $f_{RTC}/2^6$ ,  $f_{RTC}/2^7$ ,  $f_{RTC}/2^8$ ,  $f_{RTC}/2^9$ ,  $f_{RTC}/2^{10}$ ,  $f_{RTC}/2^{11}$ , or  $f_{RTC}/2^{12}$ .

### 10.5.3 Registers

The real-time counter is controlled by the following 16 types of registers.

#### (1) Real-time counter control register 0 (RC1CC0)

This register is used to select the input clock of the real-time counter.

This register can be read or written in 8-bit or 1-bit units.

Reset sets this register to 00H.

After reset: 00H								R/W	Address: FFFFADDH							
RC1CC0	<7>	6	5	4	3	2	1	0								
	RC1PWR	RC1CKS	0	0	0	0	0	0								
RC1PWR	Control of real-time counter operation															
0	Stops real-time counter operation.															
1	Enables real-time counter operation.															
RC1CKS	Selection of operating clock															
0	Selects $f_{XT}$ as operating clock.															
1	Selects $f_{BRG}$ as operating clock.															

**Cautions**

1. Stop the real-time counter (RC1PWR bit = 1 → 0) during operation as described in 10.5.4 (8) Initializing real-time counter.
2. The RC1CKS bit can be rewritten only when the operation of the real-time counter is stopped (RC1PWR bit = 0). Rewriting the RC1CKS bit as soon as setting the RC1PWR bit from “0” to “1” is prohibited.
3. Be sure to set bits 0 to 5 to “0”.

#### (2) Real-time counter control register 1 (RC1CC1)

This is an 8-bit register that starts or stops the operation of the real-time counter, controls the RC1CKO/RC1CK1HZ pin, select the 12-hour or 24-hour system, and sets the function of the periodic interrupt function.

This register can be read or written in 8-bit or 1-bit units.

Reset sets this register to 00H.

After reset: 00H R/W Address: FFFFFADEH

	<7>	6	<5>	<4>	<3>	2	1	0
RC1CC1	RTCE	0	CLOE1	CLOE0	AMPM	CT2	CT1	CT0
	RTCE	Control of operation of each counter						
	0	Stops counter operation.						
	1	Enables counter operation.						
	CLOE1	Output control of RC1CK1HZ pin						
	0	Disables output by RC1CK1HZ pin (1 Hz).						
	1	Enables output by RC1CK1HZ pin (1 Hz).						
	CLOE0	Output control of RC1CKO pin						
	0	Disables output by RC1CKO pin (32.768 kHz)						
	1	Enables output by RC1CKO pin (32.768 kHz)						
	AMPM	Selection of 12- or 24-hour system						
	0	12-hour display (a.m./p.m. indicated)						
	1	24-hour display						
	CT2	CT1	CT0	Selection of periodic interrupt (INTRTC0)				
	0	0	0	Periodic interrupt is not used.				
	0	0	1	Once every 0.5 second (as soon as second counter is up)				
	0	1	0	Once every 1 second (as soon as second counter is up)				
	0	1	1	Once every 1 minute (00 second at every minute)				
	1	0	0	Once every 1 hour (00 minute 00 second at every hour)				
	1	0	1	Once every 1 day (00 hour 00 minute 00 second at every day)				
	1	1	×	Once every 1 month (00 hour 00 minute 00 second in the morning of the first day of every month)				

- Cautions**
- Writing “0” to the RTCE bit is prohibited while the RTCE bit = 1. Clear (0) the RTCE bit by clearing (0) the RC1PWR bit as described in 10.5.4 (8) Initializing real-time counter.
  - The RC1CK1HZ output pin operates as follows when the setting of the CLOE1 bit is changed.
    - If CLOE1 bit is changed from 0 to 1: RC1CK1HZ outputs a pulse of 1 Hz after up to 2 clocks.
    - If CLOE1 bit is changed from 1 to 0: RC1CK1HZ output is stopped after up to 2 clocks (fixed to low level).
  - For how to set or change the AMPM bit, refer to 10.5.4 (1) Initialization and 10.5.4 (2) Rewriting each counter during clock operation. When the AMPM bit has been rewritten, re-set the RC1HOUR register.
  - To rewrite the CT2 to CT0 bits while the real-time counter is operating (RC1PWR bit = 1), refer to 10.5.4 (4) Changing setting of INTRTC0 interrupt during clock operation.
  - Be sure to set bit 6 to “0”.

**(3) Real-time counter control register 2 (RC1CC2)**

This is an 8-bit register that is used to control the alarm interrupt function and the wait state of the counter.

This register can be read or written in 8-bit or 1-bit units.

Reset sets this register to 00H.

After reset: 00H R/W Address: FFFFFADFH

	<7>	6	5	4	3	2	<1>	0
RC1CC2	WALE	0	0	0	0	0	RWST	RWAIT

WALE	Control of operation of alarm interrupt (INTRTC1)
0	Does not generate interrupt when alarm matches.
1	Generates interrupt when alarm matches.

RWST	Wait state of real-time counter
0	Counter is operating.
1	Counting up of the second to year counters is stopped (reading or writing the count value is enabled).

This is a status flag that indicates whether the RWAIT bit can be set. Before reading or writing a count value, be sure to confirm that the RWST bit is 1.

RWAIT	Wait control of real-time counter
0	Sets counter operation.
1	Stops counting operation of second to year counters (mode to read or write count value).

This bit controls the operation of the counter. Be sure to write "1" to this bit when the count value is to be read or written. If an overflow occurs in the RC1SUBC register while the RWAIT bit is "1", the overflow information is internally retained, "0" is written to the RWAIT bit, and the RC1SEC register is counted up after up to 2 clocks. If the value of the second counter is rewritten when the RWAIT bit = 1, the overflow information that has been retained is discarded.

- Cautions**
1. To rewrite the WALE bit while the real-time counter is operating (RC1CC0.RC1PWR bit = 1), refer to 10.5.4 (5) Changing setting of INTRTC1 interrupt during clock operation.
  2. To read or write the value of each counter, confirm that the RWST bit is 1.
  3. Even if the RWAIT bit is set to "0", the RWST bit is not set to 0 while each counter is being rewritten. It is set to 0 after writing of each counter has been completed.
  4. Be sure to set bits 2 to 6 to "0".



**(4) Real-time counter control register 3 (RC1CC3)**

This is an 8-bit register that is used to control the interval interrupt function and the RC1CKDIV pin.

This register can be read or written in 8-bit or 1-bit units.

Reset sets this register to 00H.

After reset: 00H R/W Address: FFFFFAE0H

	7	6	5	4	3	2	1	0
RC1CC3	RINTE	CLOE2	CKDIV	0	0	ICT2	ICT1	ICT0

RINTE	Control of interval interrupt (INTRTC2)
0	Interval interrupt is not generated.
1	Interval interrupt is generated.

CLOE2	Output control of RC1CKDIV pin
0	Output by RC1CKDIV pin is disabled.
1	Output by RC1CKDIV pin is enabled.

CKDIV	Selection of output frequency of RC1CKDIV pin
0	RC1CKDIV pin outputs 512 Hz (1.95 ms).
1	RC1CKDIV pin outputs 16.384 kHz (0.061 ms).

ICT2	ICT1	ICT0	Selection of interval interrupt (INTRTC2)
0	0	0	$2^9/f_{RTC}$ (1.953125 ms)
0	0	1	$2^7/f_{RTC}$ (3.90625 ms)
0	1	0	$2^8/f_{RTC}$ (7.8125 ms)
0	1	1	$2^9/f_{RTC}$ (15.625 ms)
1	0	0	$2^{10}/f_{RTC}$ (31.25 ms)
1	0	1	$2^{11}/f_{RTC}$ (62.5 ms)
1	1	×	$2^{12}/f_{RTC}$ (125 ms)

- Cautions 1.** To rewrite the RINTE bit while the real-time counter is operating (RCC1CC0.RC1PWR bit = 1), refer to 10.5.4 (7) Changing setting of INTRTC2 interrupt during clock operation.
- 2.** The RC1CKDIV output pin operates as follows when the setting of the CLOE2 bit is changed.
- When CLOE2 bit is changed from 0 to 1: The pulse set by the CKDIV bit is output after up to 2 clocks.
  - When CLOE2 bit is changed from 1 to 0: Output by the RC1CKDIV pin is stopped after up to 2 clocks (fixed to low level).
- 3.** To rewrite the ICT2 to ICT0 bits while the real-time counter is operating (RC1PWR bit = 1), refer to 10.5.4 (7) Changing setting of INTRTC2 interrupt during clock operation.
- 4.** Be sure to set bits 3 and 4 to “0”.

**(5) Subcount register (RC1SUBC)**

This is a 16-bit register that counts the reference time of 1 second of the real-time counter.

The value of this register ranges from 0000H to 7FFFH and the register counts 1 second with a clock of 32.768 kHz.

This register can only be read in 16-bit units.

Reset sets this register to 0000H.

- Cautions**
1. The value of this register may reach or exceed 8000H if the time is corrected by using the RC1SUBU register.
  2. The RC1SUBC register is also cleared by writing the second count register.
  3. The value of the RC1SUBC register is not guaranteed if it is read during operation because a value that is changing is read.

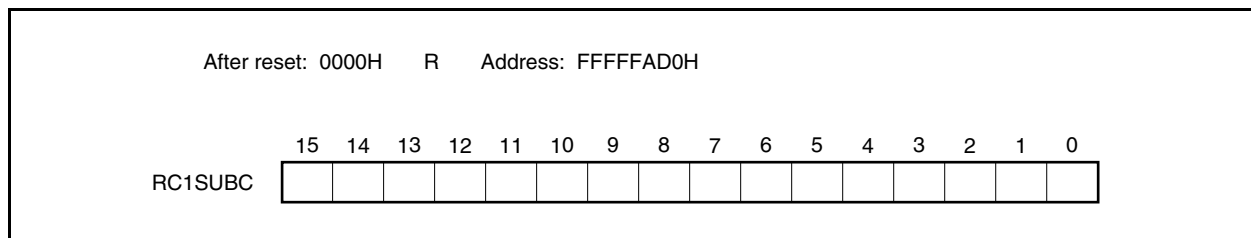

**(6) Second count register (RC1SEC)**

This is an 8-bit register that indicates the count value of seconds in a range of 0 to 59 (decimal number).

It counts up when an overflow occurs from the subcounter.

If a value is written to this register, it is written to a buffer and then to the counter after up to 2 clocks (32.768 kHz). Set a value of 00 to 59 (decimal number) to this register in BCD code.

This register can be read or written in 8-bit units.

Reset sets this register to 00H.

**Caution** Setting values other than 00 to 59 to the RC1SEC register is prohibited.

**Remark** Be sure to read or write the RC1SEC register by referring to **10.5.4 (1) Initialization**, **10.5.4 (2) Rewriting each counter during clock operation**, and **10.5.4 (3) Reading each counter during clock operation**.

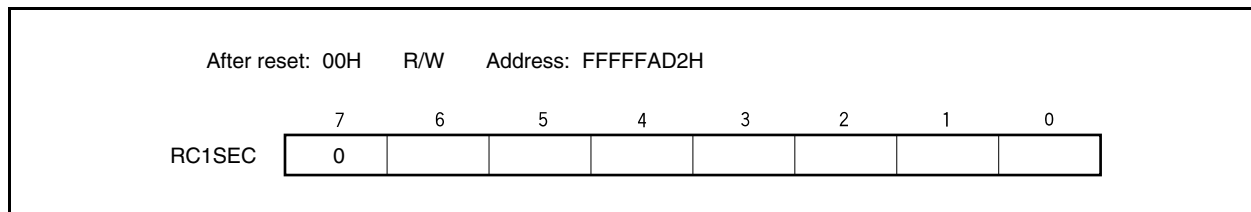

**(7) Minute count register (RC1MIN)**

This is an 8-bit register that indicates the count value of minutes in a range of 0 to 59 (decimal number).

It counts up when an overflow occurs from the second counter.

If a value is written to this register, it is written to a buffer and then to the counter after up to 2 clocks (32.768 kHz). Set a value of 00 to 59 (decimal number) to this register in BCD code.

This register can be read or written in 8-bit units.

Reset sets this register to 00H.

**Caution** Setting a value other than 00 to 59 to the RC1MIN register is prohibited.

**Remark** Be sure to read or write the RC1MIN register by referring to **10.5.4 (1) Initialization**, **10.5.4 (2) Rewriting each counter during clock operation**, and **10.5.4 (3) Reading each counter during clock operation**.

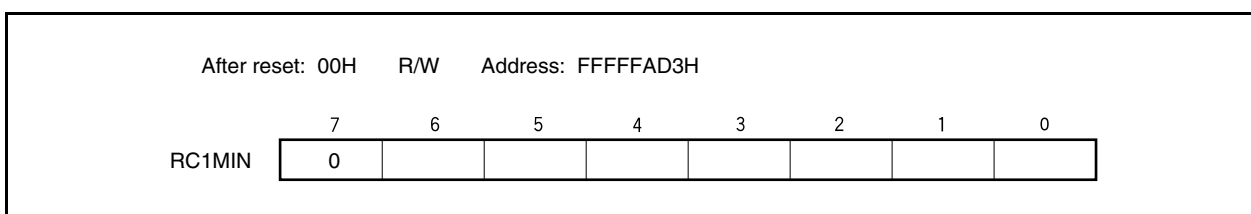
**(8) Hour count register (RC1HOUR)**

This is an 8-bit register that indicates the count value of hours in a range of 0 to 23, or 1 to 12 (decimal number).

It counts up when an overflow occurs from the minute counter.

If a value is written to this register, it is written to a buffer and then to the counter after up to 2 clocks (32.768 kHz). Set a value of 00 to 23, 01 to 12, or 21 to 32 (decimal number) to this register in BCD code.

This register can be read or written in 8-bit units.

Reset sets this register to 12H.

However, it is set to 00H if the RC1CC1.AMPM bit is set to 1.

- Cautions**
1. Bit 5 of the RC1HOUR register indicates AM (0) or PM (1) when the RC1CC1.AMPM bit = 0 (12-hour system).
  2. Setting a value other than 01 to 12, 21 to 32 (AMPM bit = 0) or 00 to 23 (AMPM bit = 1) to the RC1HOUR register is prohibited.

**Remark** Be sure to read or write the RC1HOUR register by referring to **10.5.4 (1) Initialization**, **10.5.4 (2) Rewriting each counter during clock operation**, and **10.5.4 (3) Reading each counter during clock operation**.

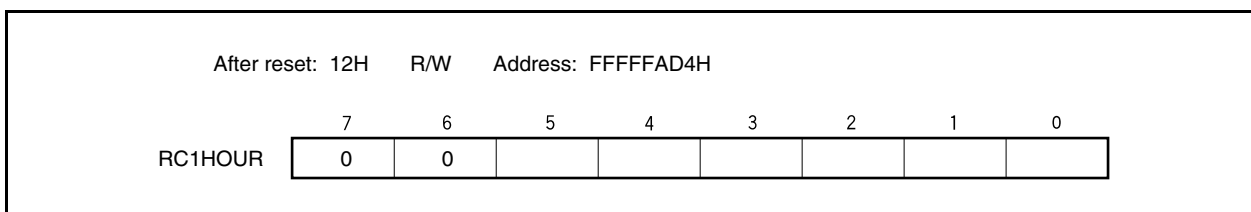

The relationship in time between the set value of the RC1CC1.AMPM bit and the value of the RC1HOUR register is shown in Table 10-4.

**Table 10-4. Time Digit Indication**

12-Hour System (AMPB Bit = 0)		24-Hour System (AMPB Bit = 1)	
Time	Value of RC1HOUR Register	Time	Value of RC1HOUR Register
0 o'clock AM	12H	0 o'clock	00H
1 o'clock AM	01H	1 o'clock	01H
2 o'clock AM	02H	2 o'clock	02H
3 o'clock AM	03H	3 o'clock	03H
4 o'clock AM	04H	4 o'clock	04H
5 o'clock AM	05H	5 o'clock	05H
6 o'clock AM	06H	6 o'clock	06H
7 o'clock AM	07H	7 o'clock	07H
8 o'clock AM	08H	8 o'clock	08H
9 o'clock AM	09H	9 o'clock	09H
10 o'clock AM	10H	10 o'clock	10H
11 o'clock AM	11H	11 o'clock	11H
0 o'clock PM	32H	12 o'clock	12H
1 o'clock PM	21H	13 o'clock	13H
2 o'clock PM	22H	14 o'clock	14H
3 o'clock PM	23H	15 o'clock	15H
4 o'clock PM	24H	16 o'clock	16H
5 o'clock PM	25H	17 o'clock	17H
6 o'clock PM	26H	18 o'clock	18H
7 o'clock PM	27H	19 o'clock	19H
8 o'clock PM	28H	20 o'clock	20H
9 o'clock PM	29H	21 o'clock	21H
10 o'clock PM	30H	22 o'clock	22H
11 o'clock PM	31H	23 o'clock	23H

The value of the RC1HOUR register is indicated in the 12-hour system when the AMPM bit is "0" and in the 24-hour system when it is "1".

In the 12-hour system, the fifth bit of RCHOUR indicates AM when it is 0 or PM when it is 1.

**(9) Day count register (RC1DAY)**

This is an 8-bit register that indicates the count value of days in a range of 1 to 31 (decimal number).

It counts up when an overflow occurs from the hour counter.

The counter counts up as follows.

- 01 to 31 (January, March, May, July, August, October, December)
- 01 to 30 (April, June, September, November)
- 01 to 29 (February of leap year)
- 01 to 28 (February of normal year)

If a value is written to this counter, it is written to a buffer and then to the counter after up to 2 clocks (32.768 kHz). Set a value of 01 to 31 (decimal number) to this register in BCD code.

This register can be read or written in 8-bit units.

Reset sets this register to 01H.

**Caution** Setting a value other than 01 to 31 to the RC1DAY register is prohibited. In addition, setting outside the above count range, such as “February 30”, is prohibited.

**Remark** Be sure to read or write the RC1DAY register by referring to **10.5.4 (1) Initialization**, **10.5.4 (2) Rewriting each counter during clock operation**, and **10.5.4 (3) Reading each counter during clock operation**.

After reset: 01H		R/W	Address: FFFFFAD6H					
	7	6	5	4	3	2	1	0
RC1DAY	0	0						

**(10) Week count register (RC1WEEK)**

This is an 8-bit register that indicates the count value of weeks in a range of 0 to 6 (decimal number).

It counts up in synchronization with the day counter.

If a value is written to this register, it is written to a buffer and then to the counter after up to 2 clocks (32.768 kHz). Set a value of 00 to 06 (decimal number) to this register in BCD code.

This register can be read or written in 8-bit units.

Reset sets this register to 00H.

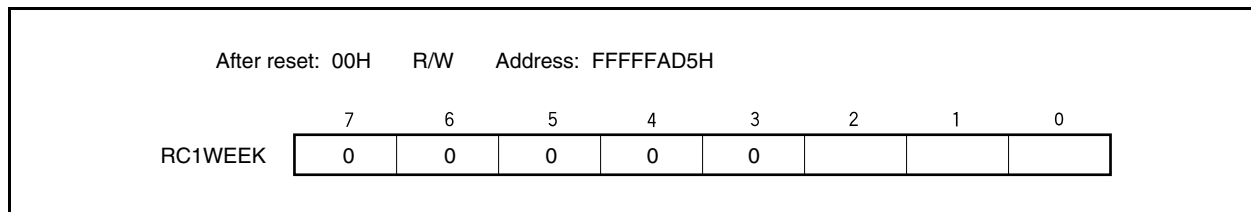

- Cautions**
1. Setting a value other than 00 to 06 to the RC1WEEK register is prohibited.
  2. A value corresponding to the month count register and day count register is not always stored automatically in the week count register.

**Be sure to set the week count register as follows after reset release.**

Day of Week	WEEK
Sunday	00H
Monday	01H
Tuesday	02H
Wednesday	03H
Thursday	04H
Friday	05H
Saturday	06H

**Remark** Be sure to read or write the RC1WEEK register by referring to **10.5.4 (1) Initialization**, **10.5.4 (2) Rewriting each counter during clock operation**, and **10.5.4 (3) Reading each counter during clock operation**.

**(11) Month count register (RC1MONTH)**

This is an 8-bit register that indicates the count value of months in a range of 0 to 12 (decimal number).

It counts up when an overflow occurs from the day counter.

If a value is written to this register, it is written to a buffer and then to the counter after up to 2 clocks (32.768 kHz). Set a value of 01 to 12 (decimal number) to this register in BCD code.

This register can be read or written in 8-bit units.

Reset sets this register to 01H.

**Caution** Setting a value other than 01 to 12 to the RC1MONTH register is prohibited.

**Remark** Be sure to read or write the RC1MONTH register by referring to **10.5.4 (1) Initialization**, **10.5.4 (2) Rewriting each counter during clock operation**, and **10.5.4 (3) Reading each counter during clock operation**.

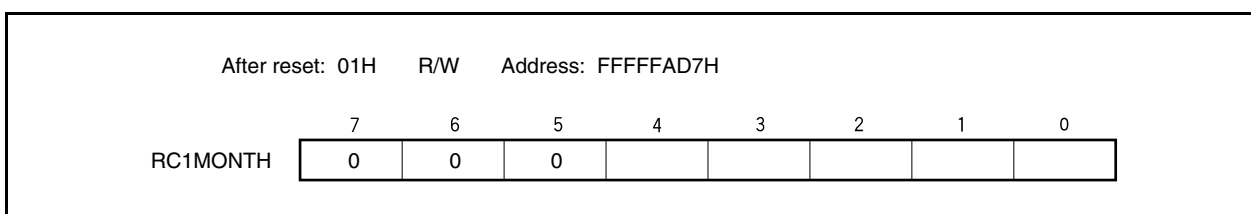
**(12) Year count register (RC1YEAR)**

This is an 8-bit register that indicates the count value of years in a range of 0 to 99 (decimal number).

It counts up when an overflow occurs from the month counter.

Leap years are set as 00, 04, 08, ..., 92, and 96.

If a value is written to this register, it is written to a buffer and then to the counter after up to 2 clocks (32.768 kHz). Set a value of 00 to 99 (decimal number) to this register in BCD code.

This register can be read or written in 8-bit units.

Reset sets this register to 00H.

**Caution** Setting a value other than 00 to 99 to the RC1YEAR register is prohibited.

**Remark** Be sure to read or write the RC1YEAR register by referring to **10.5.4 (1) Initialization**, **10.5.4 (2) Rewriting each counter during clock operation**, and **10.5.4 (3) Reading each counter during clock operation**.

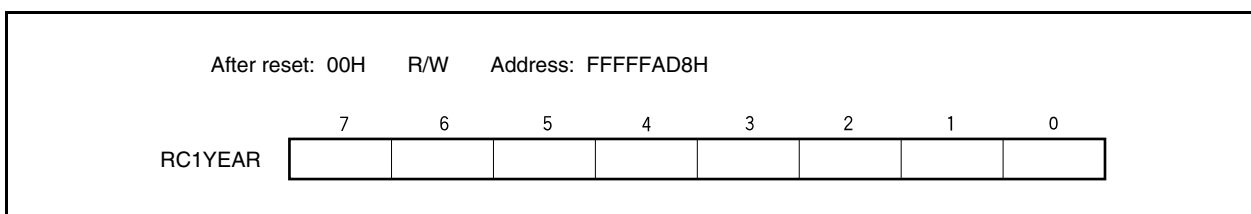

**(13) Watch error correction register (RC1SUBU)**

This register can correct the advance or delay of the watch with a high precision by changing the value (reference value: 7FFFH) that overflows from the subcount register (RSUBC) to the second count register.

This register can be read or written in 8-bit or 1-bit units.

Reset sets this register to 00H.

**Remarks 1.** The RC1SUBU register can be rewritten only when the real-time counter is initialized. Be sure to refer to **10.5.4 (1) Initialization**.

**2.** For watch error correction, refer to **10.5.4 (9) Example of correcting watch error of real-time counter**.

After reset: 00H	R/W	Address: FFFFFAD9H						
RC1SUBU	7	6	5	4	3	2	1	0
	DEV	F6	F5	F4	F3	F2	F1	F0
	DEV	Setting of timing of correcting watch error						
	0	Corrects watch error when the value of RC1SEC (second counter) is 00, 20, or 40 (every 20 seconds).						
	1	Corrects watch error when the value of RC1SEC (second counter) is 00 (every 60 seconds).						
	F6	Setting of watch error correction value						
	0	Increments the count value of RC1SUBC by a value set by the F5 to F0 bits (positive correction). Increment calculation expression: (Set value of F5 to F0 bits - 1) × 2						
	1	Decrements the count value of RC1SUBC by a value set by the F5 to F0 bits (negative correction). Decrement calculation expression: (Reverse value of set value of F5 to F0 bits + 1) × 2						
	The watch error is not corrected when the value of the F6 to F0 bits is {1/0, 0, 0, 0, 0, 0, 0, 1/0}.							



**(14) Alarm minute setting register (RC1ALM)**

This register sets the minutes of alarm.

This register can be read or written in 8-bit units.

Reset sets this register to 00H.

- Cautions**
1. Set a BCD code of 00 to 59 (decimal number) to this register. If a value other than this range is set, the alarm is not detected.
  2. To rewrite the RC1ALM register while the real-time counter is operating (RC1CC0.RC1PWR bit = 1), refer to 10.5.4 (5) Changing setting of INTRTC1 interrupt during clock operation.

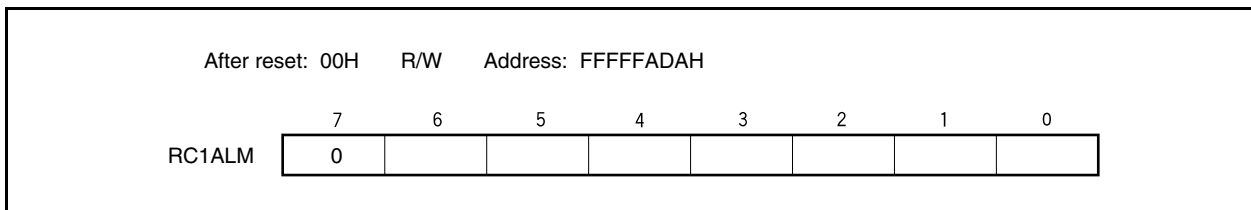

**(15) Alarm hour setting register (RC1ALH)**

This register sets the hours of alarm.

This register can be read or written in 8-bit units.

Reset sets this register to 12H.

- Cautions**
1. Set a BCD code of 00 to 23, 01 to 12, or 21 to 32 (decimal number) to this register. If a value other than this range is set, the alarm is not detected.
  2. Bit 5 of the RC1ALH register indicates AM (0) or PM (1) if the AMPM bit = 0 (12-hour system).
  3. To rewrite the RC1ALH register while the real-time counter is operating (RC1CC0.RC1PWR bit = 1), refer to 10.5.4 (5) Changing setting of INTRTC1 interrupt during clock operation.

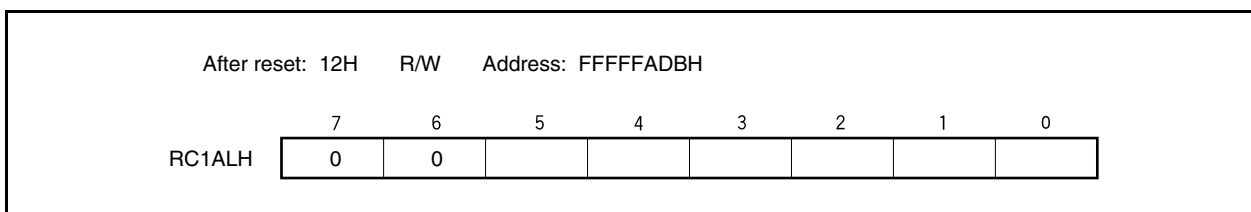

**(16) Alarm week setting register (RC1ALW)**

This register sets the weeks of alarm.

This register can be read or written in 8-bit units.

Reset sets this register to 00H.

**Caution** To rewrite the RC1ALW register while the real-time counter is operating (RC1CC0.RC1PWR bit = 1), refer to 10.5.4 (5) Changing setting of INTRTC1 interrupt during clock operation.

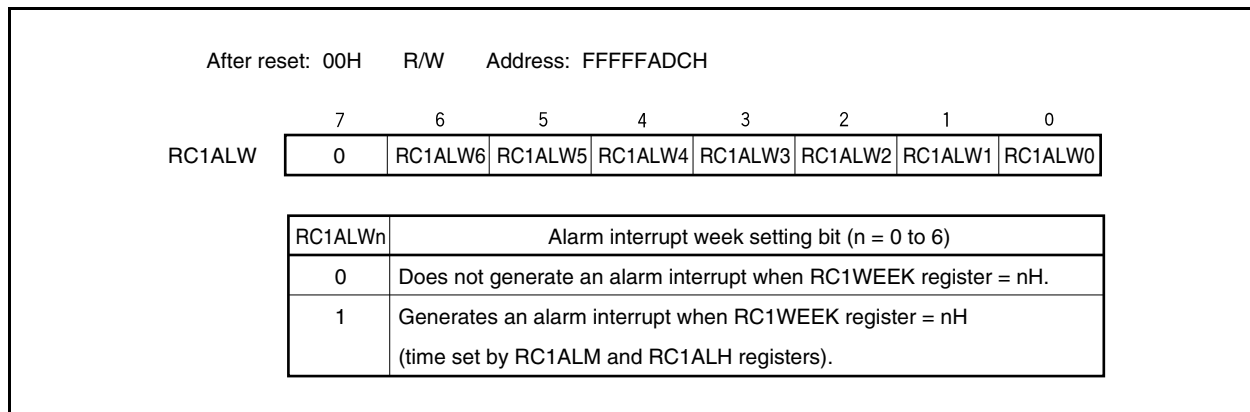

**(a) Example of setting alarm interrupt (example of setting RC1ALM, RC1ALH, and RC1ALW registers)**

Tables 10-5 and 10-6 show an example of setting where RC1WEEK register = 00H for Sundays, RC1WEEK register = 01H for Mondays, RC1WEEK register = 02H for Tuesdays, and RC1WEEK register = 06H for Saturdays.

**Table 10-5. Example of Setting Alarm When RC1CC1.AMPM Bit = 0 (In 12-Hour System of RC1HOUR Register)**

Register	RC1ALW	RC1ALH	RC1ALM
Alarm Setting Time			
AM 7:00, Sunday	01H	07H	00H
PM 12:15, Sunday and Monday	03H	32H	15H
PM 5:30, Monday, Tuesday, and Friday	26H	25H	30H
PM 10:45, every day	7FH	30H	45H

**Table 10-6. Example of Setting Alarm When RC1CC1.AMPM Bit = 1 (In 24-Hour System of RC1HOUR Register)**

Register	RC1ALW	RC1ALH	RC1ALM
Alarm Setting Time			
AM 7:00, Sunday	01H	07H	00H
PM 12:15, Sunday and Monday	03H	12H	15H
17:30, Monday, Tuesday, and Friday	26H	17H	30H
22:45, every day	7FH	22H	45H

## 10.5.4 Operation

## (1) Initialization

Initialization should be executed when the watch function or periodic interrupt operation is to be performed.

Figure 10-7. Initialization Procedure

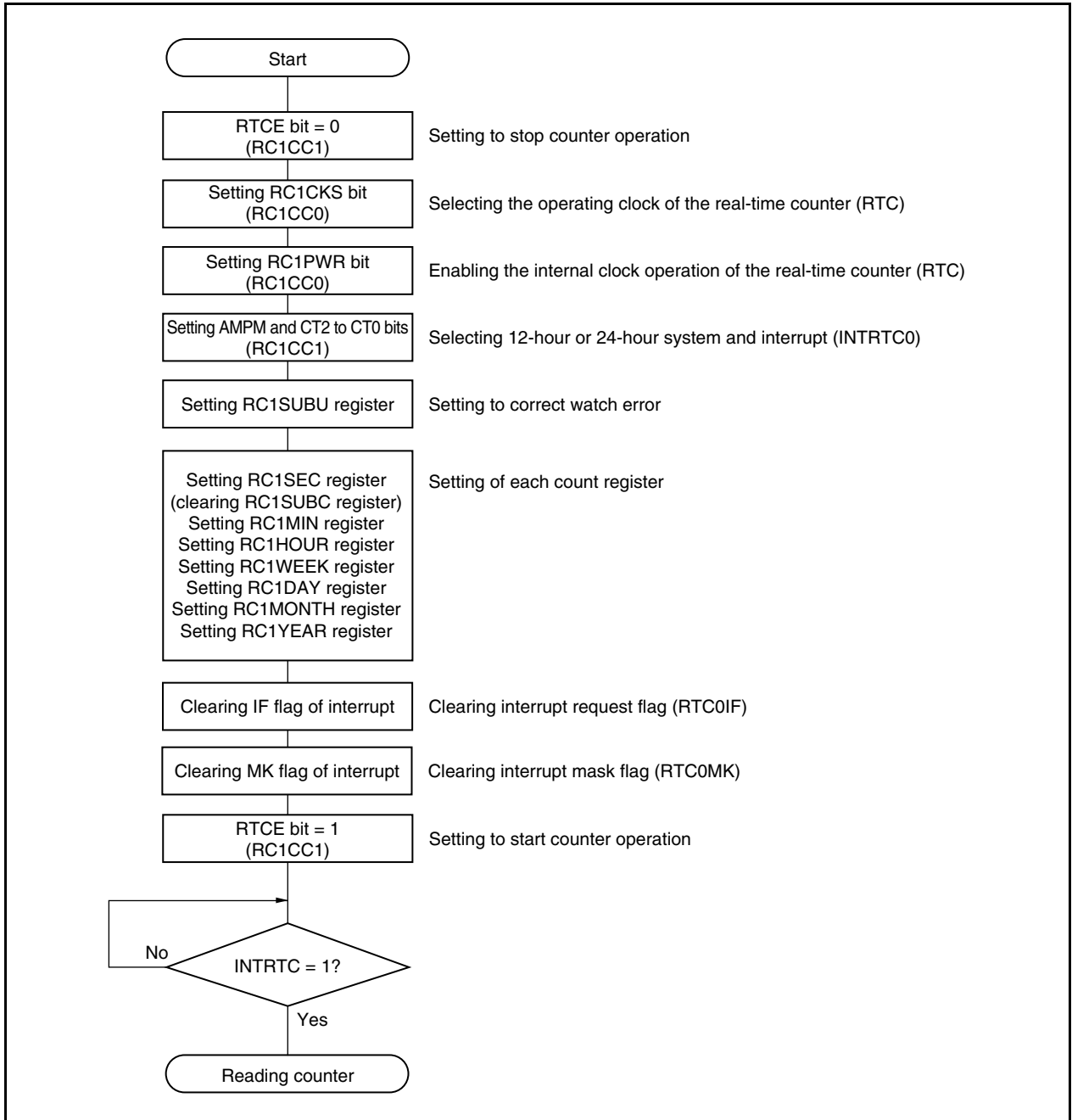

**(2) Rewriting each counter during clock operation**

Make the following setting to rewrite each counter (RC1SEC, RC1MIN, RC1HOUR, RC1WEEK, RC1DAY, RC1MONTH, or RC1YEAR register) during clock operation (RC1CC0.RC1PWR bit = 1).

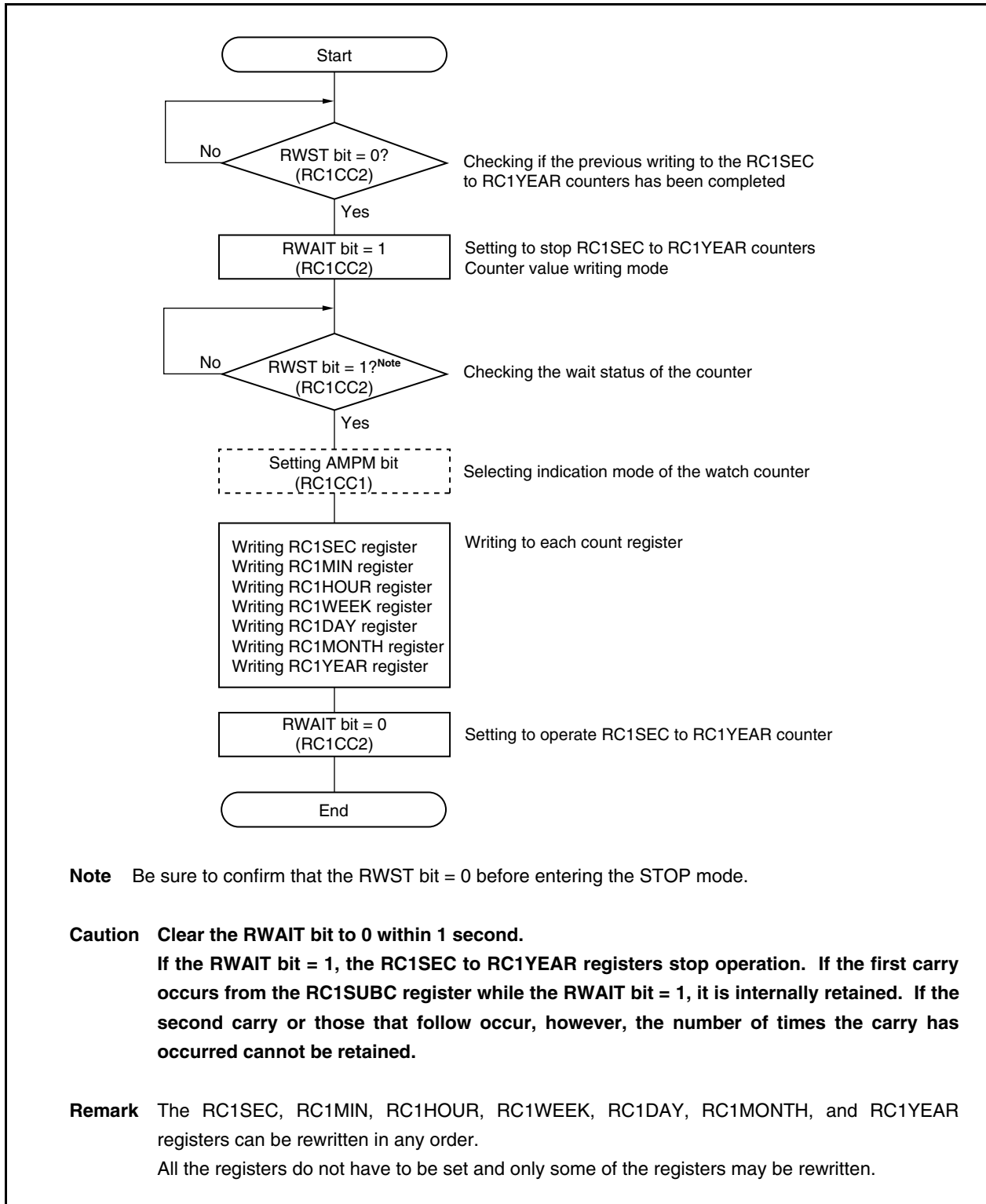
**Figure 10-8. Rewriting Each Counter During Clock Operation**

**(3) Reading each counter during clock operation**

Read each counter (RC1SEC, RC1MIN, RC1HOUR, RC1WEEK, RC1DAY, RC1MONTH, or RC1YEAR register) during clock operation (RC1CC0.RC1PWR bit = 1) as follows.

**Figure 10-9. Reading Each Counter During Clock Operation**

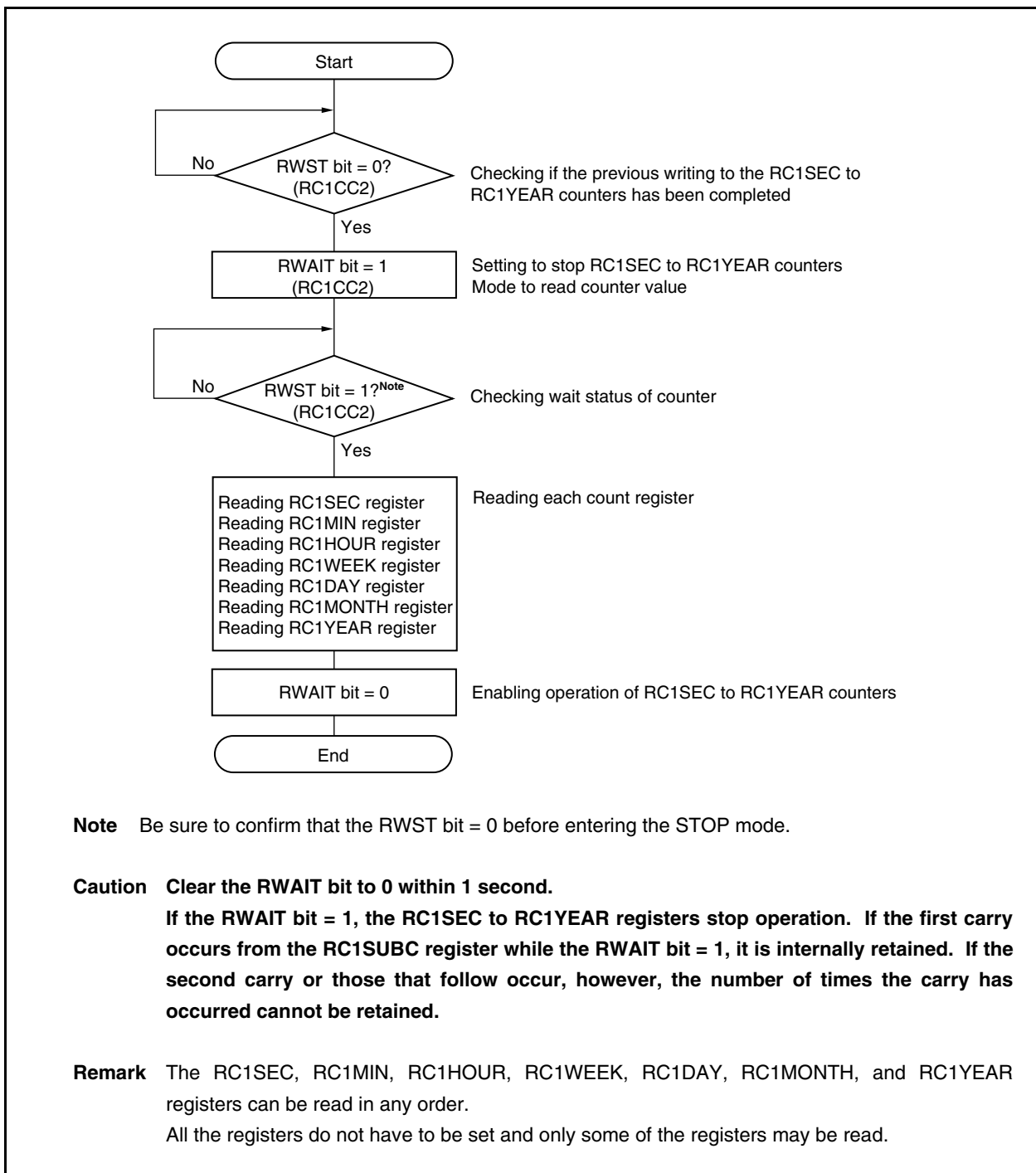

**(4) Changing setting of INTRTC0 interrupt during clock operation**

If the setting of the INTRTC0 interrupt (periodic interrupt) is changed during the clock operation of the real-time counter (RC1CC0.RC1PWR bit = 1), a whisker may be generated on the waveform of the INTRTC0 interrupt and an unintended signal may be output. To mask the whisker, change the setting of the INTRTC0 interrupt request signal as follows during clock operation (RC1PWR bit = 1).

**Figure 10-10. Changing Setting of INTRTC0 Interrupt During Clock Operation**

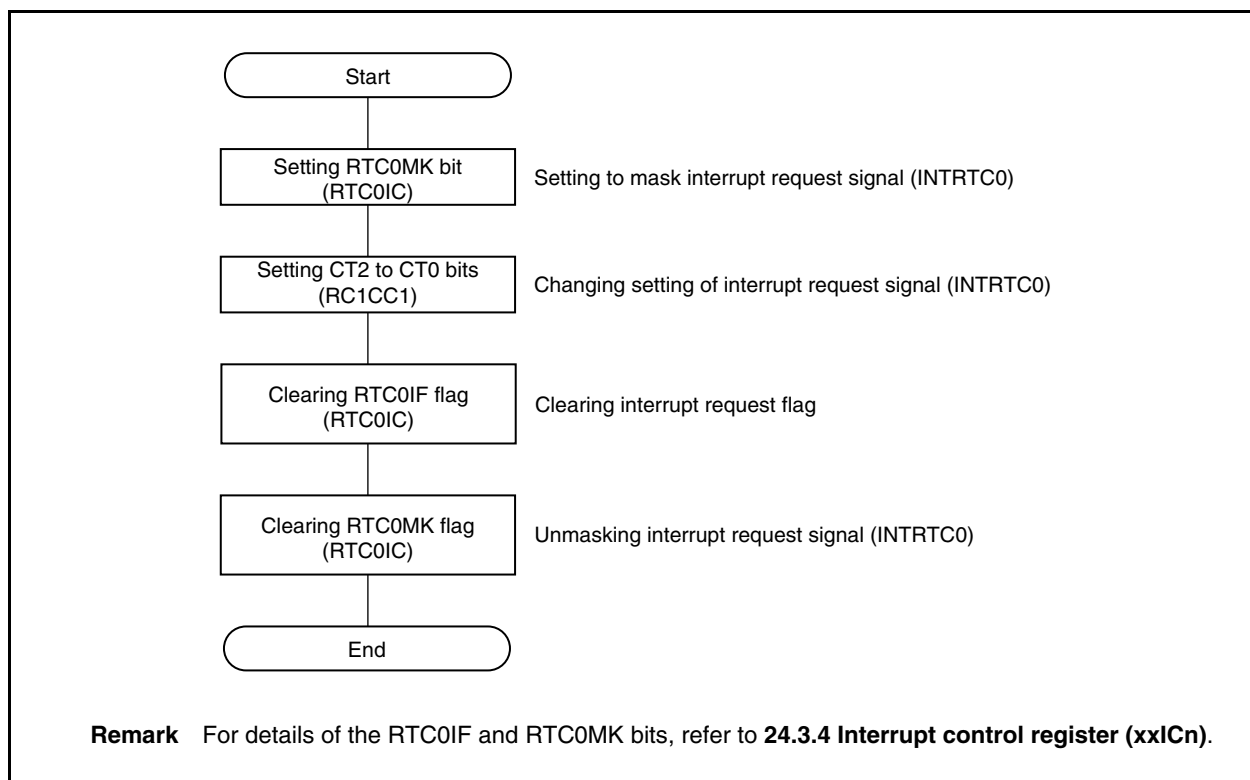

**(5) Changing setting of INTRTC1 interrupt during clock operation**

If the setting of the INTRTC1 interrupt (alarm interrupt) is changed during the clock operation of the real-time counter (RC1CC0.RC1PWR bit = 1), a whisker may be generated on the waveform of the INTRCT1 interrupt and an unintended signal may be output. To mask the whisker, change the setting of the INTRTC1 interrupt request signal as follows during clock operation (RC1PWR bit = 1).

**Figure 10-11. Changing Setting of INTRTC1 Interrupt During Clock Operation**

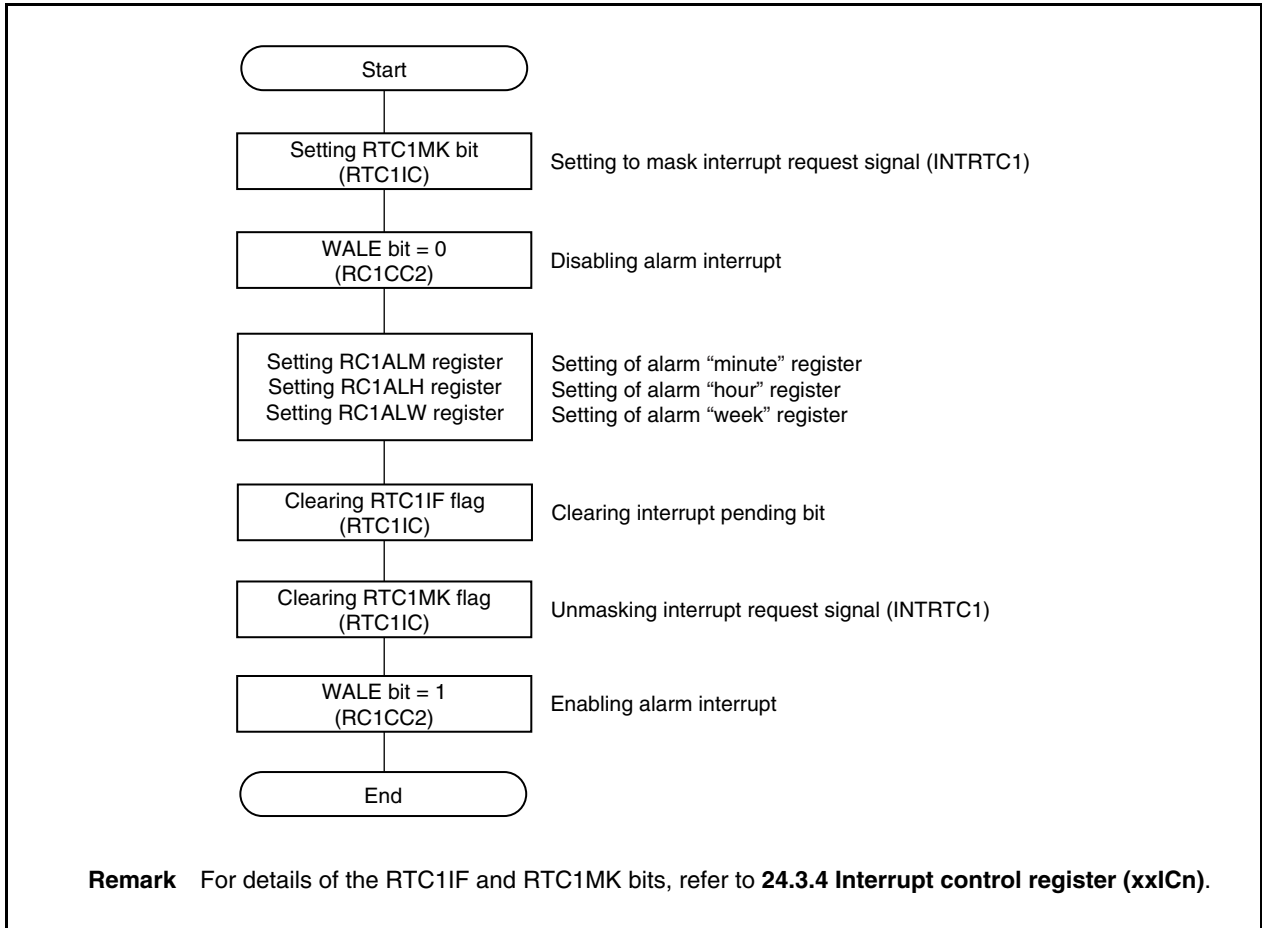

**(6) Initial setting of INTRTC2 interrupt**

Set the INTRTC1 interrupt (interval interrupt) as follows.

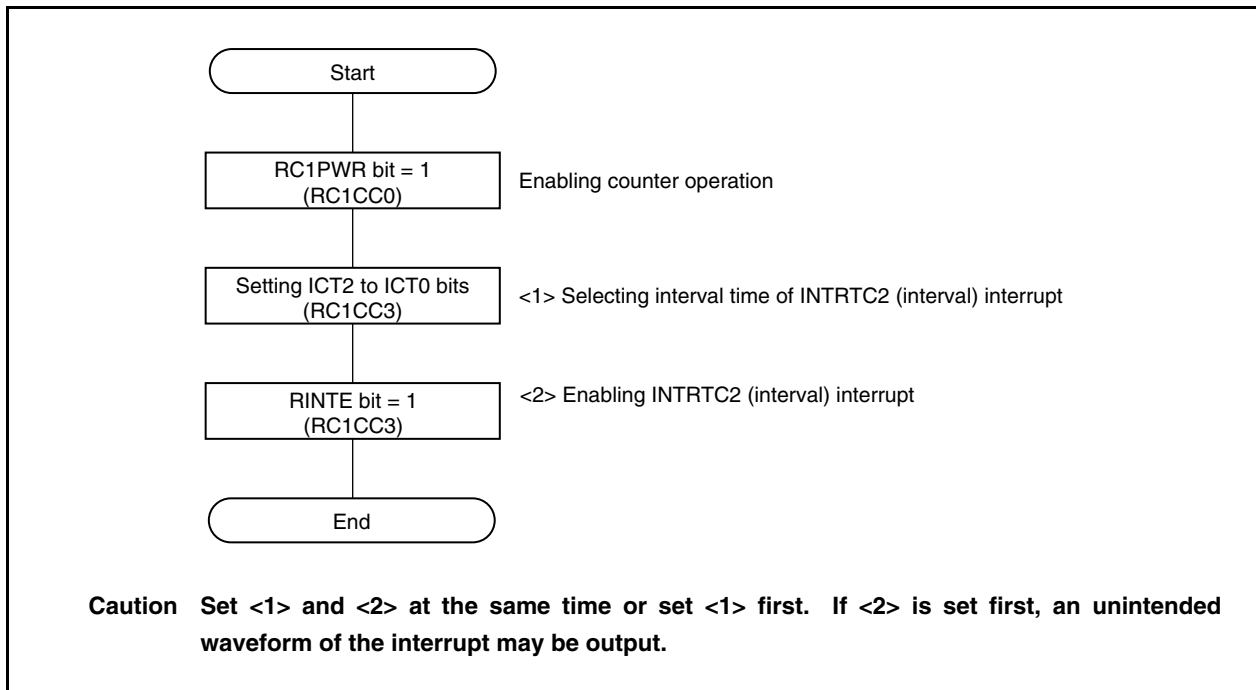
**Figure 10-12. Setting of INTRTC2 Interrupt**



**(7) Changing setting of INTRTC2 interrupt during clock operation**

If the setting of the INTRTC2 interrupt (interval interrupt) is changed during clock operation of the real-time counter (RC1CC0.RC1PWR bit = 1), a whisker may be generated on the waveform of the INTRCT2 interrupt and an unintended signal may be output. To mask the whisker, change the setting of the INTRTC2 interrupt request signal as follows during clock operation (RC1PWR bit = 1).

**Figure 10-13. Changing Setting of INTRTC2 Interrupt During Clock Operation**

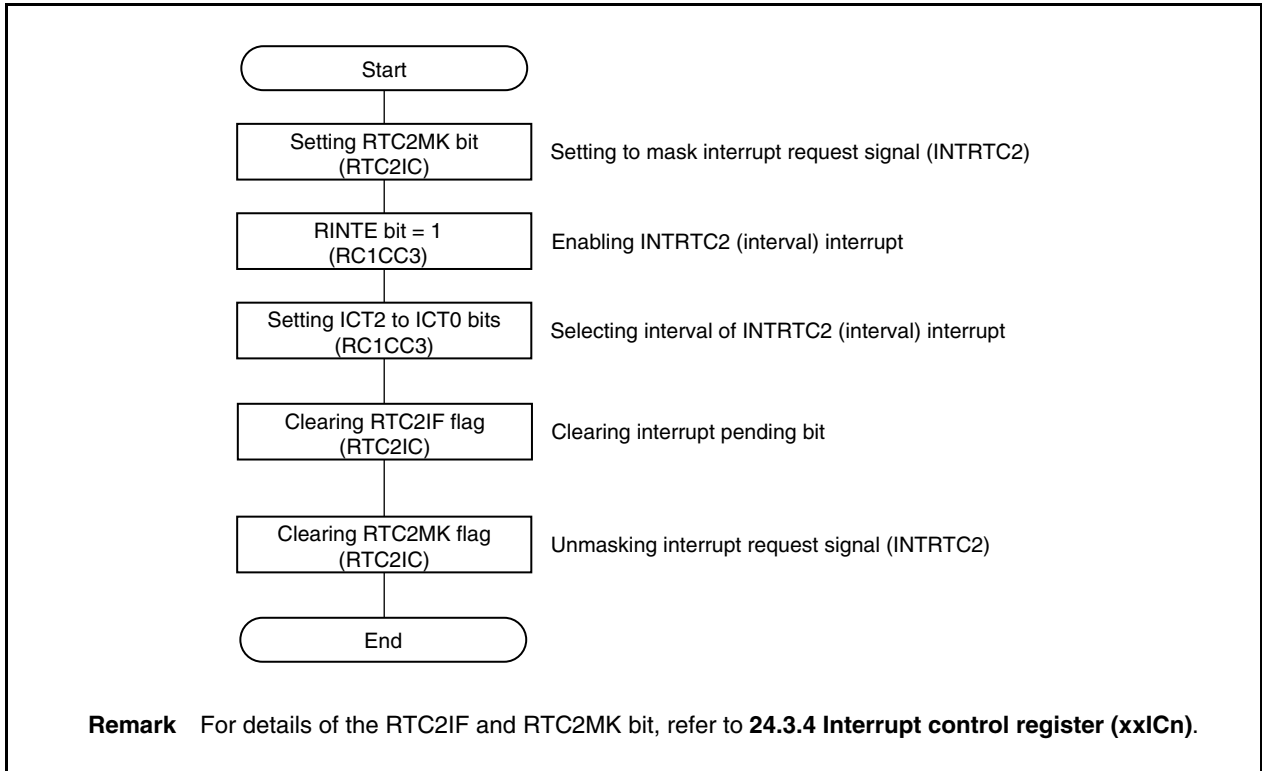

**(8) Initializing real-time counter**

The following figure shows the procedure for initializing the real-time counter

**Figure 10-14. Initializing Real-Time Counter**

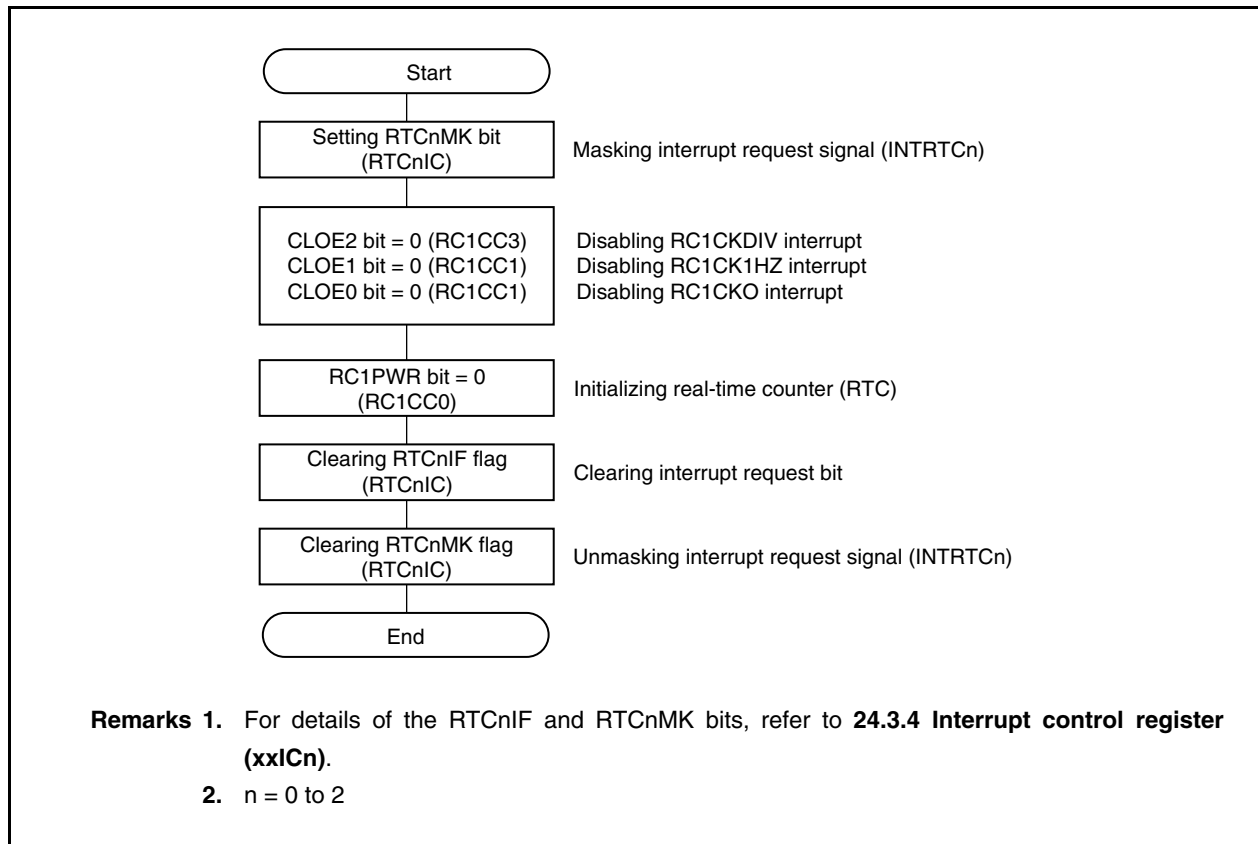

**(9) Example of correcting watch error of real-time counter**

The watch error correction function is to correct the deviation of the oscillation frequency of the resonator connected to the V850E/SJ3-H or V850E/SK3-H.

The “deviation” means the “constant deviation” of the frequency of the resonator when the resonator was designed.

A timing chart where a 32.768 kHz resonator is connected to the device when the system is designed, because an error occurs in the intended input clock “32.768 kHz”, and the counting operation of the RC1SUBC and RC1SEC registers to correct that error are shown below.

**Figure 10-15. Example of Watch Error Correction**

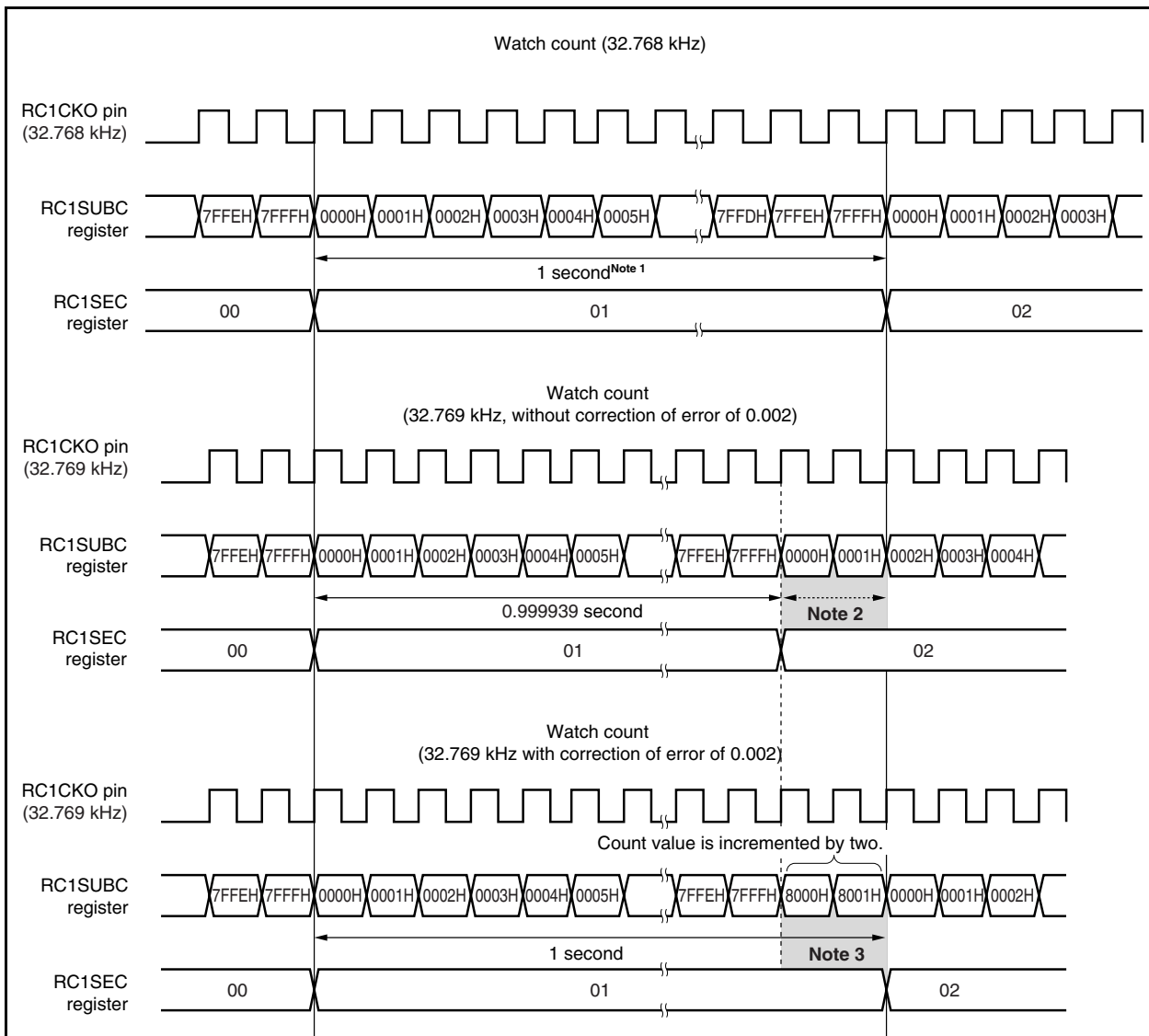

- Notes**
- One second is counted by counting 32768 (0000H to 7FFFH) clocks of 32.768 kHz.
  - $32768/32770 \approx 0.999939$  second if 32768 (0000H to 7FFFH) clocks of 32.770 kHz are counted. In this case, an error of  $-158.2$  seconds  $\approx (32768/32770 - 1) \times 60$  (seconds)  $\times 60$  (minutes)  $\times 24$  (hours)  $\times 30$  (days) is generated per month.
  - One second can be counted without an error by counting 32770 (0000H to 8001H) clocks of 32.770 kHz.

If a “positive error” that is faster than 32.768 kHz occurs on the resonator, as shown in Figure 10-15, the watch can be accurately counted by increasing the count value of the RC1SUBC register. Similarly, if a “negative error” that is slower than 32.768 kHz occurs on the resonator, the watch can be accurately counted by decreasing the count value of the RC1SUBC register.

Whether the value of the RC1SUBC register is to be increased or decreased is determined by the F6 to F0 bits, and the value by which the register value is to be increased or decreased is determined by the F5 to F0 bits.

**(a) Increasing count value of RC1SUBC register**

When the F6 bit = 0, the count value of the RC1SUBC register is increased by the value set by the F5 to F0 bits.

Expression for calculating increment:  $(\text{Set value of F5 to F0 bits} - 1) \times 2$

[Example of increasing count value of RC1SUBC register: F6 bit = 0]

If 15H (010101B) is set to the F5 to F0 bits

$(15H - 1) \times 2 = 40$  (increases count value of RC1SUBC register by 40)

Count value of RC1SUBC register =  $32768 + 40 = 32808$

**(b) Decreasing count value of RC1SUBC register**

When the F6 bit = 1, the count value of the RC1SUBC register is decreased by the inverted value of the value set to the F5 to F0 bits.

Expression for calculating decrement:  $(\text{Inverted value of set value of F5 to F0 bits} + 1) \times 2$

[Example of decreasing count value of RC1SUBC register: F6 bit = 1]

If 15H (010101B) is set to the F5 to F0 bits

Inverted data of 15H (010101B) = 2AH (101010B)

$(2AH + 1) \times 2 = 86$  (decreases count value of RC1SUBC register by 86)

Count value of RC1SUBC register =  $32768 - 86 = 32682$

**(c) RC1SUBU.DEV bit**

The RC1SUBU.DEV bit determines the timing in which the setting of the F6 to F0 bits is valid.

The value set by the F6 to F0 bits is not always reflected on the count value of the RC1SUBC register but it is reflected in the following timing.

**Table 10-7. Setting of DEV Bit**

Value of DEV Bit	Timing of Reflection on RC1SUBC Register
When 0	When RC1SEC register is 00, 20, or 40
When 1	When RC1SEC register is 00

[Example when 0010101B is set to F6 to F0 bits]

- When DEV bit = 0  
The count value of the RC1SUBC register is 00, 20, or 40 seconds, “32808”; otherwise, it is “32768”.
- When DEV bit = 1  
The count value of the RC1SUBC register is 00 seconds, “32808”; otherwise, it is “32768”.

The count value of the RC1SUBC register is not corrected every second but every 20 or 60 seconds, in accordance with the deviation range of the resonator.

The frequency range of the resonator that actually can be corrected is as follows.

- When DEV bit = 0: 32.76180000 kHz to 32.77420000 kHz
- When DEV bit = 1: 32.76593333 kHz to 32.77006667 kHz

When the DEV bit = 0, a frequency range three times wider than when the DEV bit = 1 can be corrected.

However, when the DEV bit = 1, the frequency can be set with an accuracy three times higher than when the DEV bit = 0.

Tables 10-8 and 10-9 show the set values of the DEV bit and F6 to F0 bits and a list of the frequencies that can be corrected.

**Table 10-8. Frequency Range Correctable When DEV Bit = 0**

F6 Bit	F5 to F0 Bits	RC1SUBC Register Correction Value	Connected Clock Frequency (with constant deviation included)
0	000000	No correction	–
0	000001	No correction	–
0	000010	Increments RC1SUBC register count value by +2 once every 20 seconds	32.76810000 kHz
0	000011	Increments RC1SUBC register count value by +4 once every 20 seconds	32.76820000 kHz
0	000100	Increments RC1SUBC register count value by +6 once every 20 seconds	32.76830000 kHz
		⋮	
0	111011	Increments RC1SUBC register count value by +120 once every 20 seconds	32.77400000 kHz
0	111110	Increments RC1SUBC register count value by +122 once every 20 seconds	32.77410000 kHz
0	111111	Increments RC1SUBC register count value by +124 once every 20 seconds	32.77420000 kHz (upper limit)
1	000000	No correction	–
1	000001	No correction	–
1	000010	Decrements RC1SUBC register count value by –124 once every 20 seconds	32.76180000 kHz (lower limit)
1	000011	Decrements RC1SUBC register count value by –122 once every 20 seconds	32.76190000 kHz
1	000100	Decrements RC1SUBC register count value by –120 once every 20 seconds	32.76200000 kHz
		⋮	
1	11011	Decrements RC1SUBC register count value by –6 once every 20 seconds	32.76770000 kHz
1	11110	Decrements RC1SUBC register count value by –4 once every 20 second	32.76780000 kHz
1	11111	Decrements RC1SUBC register count value by –2 once every 20 seconds	32.76790000 kHz

**Table 10-9. Frequency Range Correctable When DEV Bit = 1**

F6 Bit	F5 to F0 Bits	RC1SUBC Register Correction Value	Connected Clock Frequency (with constant deviation included)
0	000000	No correction	–
0	000001	No correction	–
0	000010	Increments RC1SUBC register count value by +2 once every 60 seconds	32.76803333 kHz
0	000011	Increments RC1SUBC register count value by +4 once every 60 seconds	32.76806667 kHz
0	000100	Increments RC1SUBC register count value by +6 once every 60 seconds	32.76810000 kHz
		⋮	
0	111011	Increments RC1SUBC register count value by +120 once every 60 seconds	32.77000000 kHz
0	111110	Increments RC1SUBC register count value by +122 once every 60 seconds	32.77003333 kHz
0	111111	Increments RC1SUBC register count value by +124 once every 60 seconds	32.77006667 kHz (upper limit)
1	000000	No correction	–
1	000001	No correction	–
1	000010	Decrements RC1SUBC register count value by –124 once every 60 seconds	32.76593333 kHz (lower limit)
1	000011	Decrements RC1SUBC register count value by –122 once every 60 seconds	32.76596667 kHz
1	000100	Decrements RC1SUBC register count value by –120 once every 60 seconds	32.76600000 kHz
		⋮	
1	11011	Decrements RC1SUBC register count value by –6 once every 60 seconds	32.76790000 kHz
1	11110	Decrements RC1SUBC register count value by –4 once every 60 seconds	32.76793333 kHz
1	11111	Decrements RC1SUBC register count value by –2 once every 60 seconds	32.76796667 kHz

## CHAPTER 11 FUNCTIONS OF WATCHDOG TIMER 2

### 11.1 Functions

Watchdog timer 2 has the following functions.

- Default-start watchdog timer<sup>Notes 1, 2</sup>
  - Reset mode: Reset operation upon overflow of watchdog timer 2 (generation of WDT2RES signal)
  - Non-maskable interrupt request mode: NMI operation upon overflow of watchdog timer 2 (generation of INTWDT2 signal)<sup>Note 3</sup>
- Input selectable from main clock, internal oscillation clock, and subclock as the source clock
- When the WDTMD1 bit of the option byte 0000007AH (see **CHAPTER 33 OPTION BYTE FUNCTION**) is set to 1, the operation mode of watchdog timer 2 can be fixed to reset mode ( $2^{12}/f_R$  to  $2^{19}/f_R$  selectable)<sup>Note 4</sup> and the source clock can be fixed to internal oscillation clock.

- Notes**
1. When watchdog timer 2 is not used or when changing the operation mode, be sure to always set the WDTMD1 bit of the option byte 0000007AH to 0. Changing modes with the WDTM2 register when the WDTMD1 bit is set to 1 is invalid.
  2. Watchdog timer 2 automatically starts in the reset mode following reset release.  
When watchdog timer 2 is not used, either stop its operation before reset is executed via this function, or clear watchdog timer 2 once and stop it within the next interval time.  
Also, write to the WDTM2 register for verification purposes only once, even if the default settings (reset mode, interval time:  $f_R/2^{19}$ ) do not need to be changed.
  3. For the non-maskable interrupt servicing due to a non-maskable interrupt request signal (INTWDT2), see **24.2.2 (2) INTWDT2 signal**.
  4. If a reset mode is fixed (WDTMD1 bit = 1) by the option byte 0000007AH, changing modes by using the WDTM2 register becomes invalid; therefore, it can be used as a way to prevent erroneous write operation due to a CPU hang-up.

## 11.2 Configuration

The following shows the block diagram of watchdog timer 2.

Figure 11-1. Block Diagram of Watchdog Timer 2

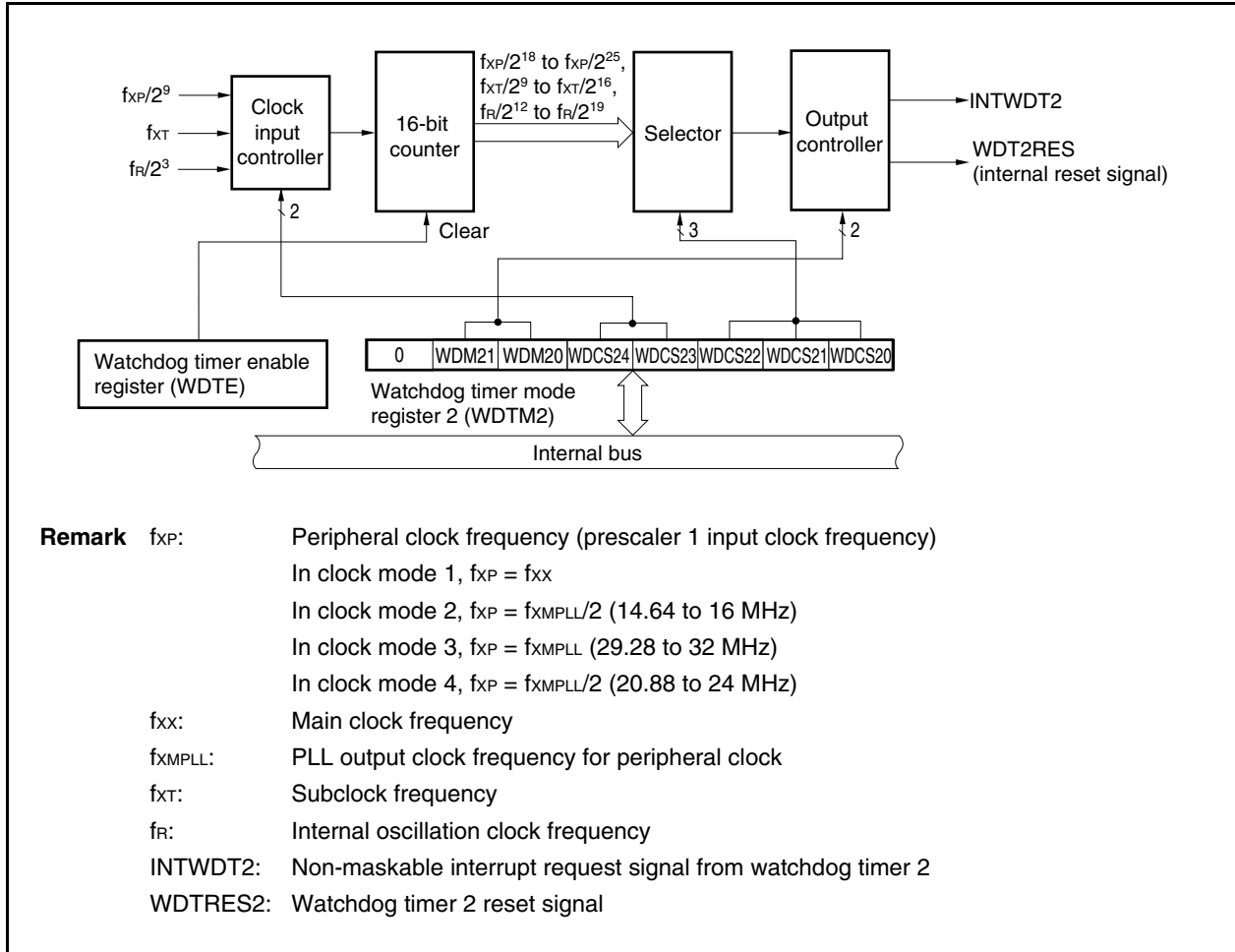

Watchdog timer 2 consists of the following hardware.

Table 11-1. Configuration of Watchdog Timer 2

Item	Configuration
Control registers	Watchdog timer mode register 2 (WDTM2) Watchdog timer enable register (WDTE)



### 11.3 Registers

#### (1) Watchdog timer mode register 2 (WDTM2)

The WDTM2 register sets the overflow time and operation clock of watchdog timer 2.

This register can be read or written in 8-bit units. This register can be read any number of times, but it can be written only once following reset release.

Reset sets this register to 67H.

**Caution** Accessing the WDTM2 register is prohibited in the following statuses. For details, refer to 3.4.9 (2) Accessing specific on-chip peripheral I/O registers.

- When the CPU operates with the subclock and the main clock oscillation is stopped
- When the CPU operates with the internal oscillation clock

(1/2)

After reset: 67H    R/W    Address: FFFFF6D0H

	7	6	5	4	3	2	1	0
WDTM2	0	WDM21	WDM20	WDCS24	WDCS23	WDCS22	WDCS21	WDCS20

WDM21	WDM20	Selection of operation mode of watchdog timer 2 <sup>Note</sup>
0	0	Stops operation
0	1	Non-maskable interrupt request mode (generation of INTWDT2 signal)
1	–	Reset mode (generation of WDT2RES signal)

**Note** When the WDTMD1 bit of the option byte 0000007AH (see **CHAPTER 33 OPTION BYTE FUNCTION**) is set to 1, the reset mode is fixed.

- Cautions**
1. When watchdog timer 2 is not used or when changing the operation mode, be sure to always set the WDTMD1 bit of the option byte 0000007AH to 0. Changing modes with the WDTM2 register when the WDTMD1 bit is set to 1 is invalid.
  2. For details of the WDCS20 to WDCS24 bits, see Table 11-2 Watchdog Timer 2 Clock Selection.
  3. Although watchdog timer 2 can be stopped just by stopping the operation of the internal oscillator, clear the WDTM2 register to 00H to securely stop the timer (to avoid selection of the main clock or subclock due to an erroneous write operation).
  4. If the WDTM2 register is rewritten twice after reset, an overflow signal is forcibly generated and the counter is reset.
  5. To intentionally generate an overflow signal, write to the WDTM2 register only twice or write a value other than “ACH” to the WDTE register once.  
However, when watchdog timer 2 is set to stop operation, an overflow signal is not generated even if data is written to the WDTM2 register only twice, or a value other than “ACH” is written to the WDTE register only once.
  6. To stop the operation of watchdog timer 2, set the RCM.RSTOP bit to 1 (to stop the internal oscillator) and write 00H in the WDTM2 register. If the RCM.RSTOP bit cannot be set to 1, set the WDCS23 bit to 1 ( $2^n/f_{XP}$  is selected and the clock can be stopped in the IDLE1, IDLE2, sub-IDLE, and subclock operation modes).  
However, when the WDTMD1 bit of the option byte 0000007AH (see CHAPTER 33 OPTION BYTE FUNCTION) is set to 1, the clock cannot be stopped other than be reset.
  7. Be sure to clear bit 7 to “0”.

**Remark**

$f_{XP}$ : Peripheral clock frequency (prescaler 1 input clock frequency)  
 In clock mode 1,  $f_{XP} = f_{XX}$   
 In clock mode 2,  $f_{XP} = f_{XMPLL}/2$  (14.64 to 16 MHz)  
 In clock mode 3,  $f_{XP} = f_{XMPLL}$  (29.28 to 32 MHz)  
 In clock mode 4,  $f_{XP} = f_{XMPLL}/2$  (20.88 to 24 MHz)

$f_{XX}$ : Main clock frequency

$f_{XMPLL}$ : PLL output clock frequency for peripheral clock

Table 11-2. Watchdog Timer 2 Clock Selection

WDCS24	WDCS23	WDCS22	WDCS21	WDCS20	Selected Clock	100 kHz (MIN.)	220 kHz (TYP.)	400 kHz (MAX.)	
0	0	0	0	0	$2^{12}/f_R$	41.0 ms	18.6 ms	10.2 ms	
0	0	0	0	1	$2^{13}/f_R$	81.9 ms	37.2 ms	20.5 ms	
0	0	0	1	0	$2^{14}/f_R$	163.8 ms	74.5 ms	41.0 ms	
0	0	0	1	1	$2^{15}/f_R$	327.7 ms	148.9 ms	81.9 ms	
0	0	1	0	0	$2^{16}/f_R$	655.4 ms	297.9 ms	163.8 ms	
0	0	1	0	1	$2^{17}/f_R$	1310.7 ms	595.8 ms	327.7 ms	
0	0	1	1	0	$2^{18}/f_R$	2621.4 ms	1191.6 ms	655.4 ms	
0	0	1	1	1	$2^{19}/f_R$	5242.9 ms	2383.1 ms	1310.7 ms	
						$f_{XP} = 32 \text{ MHz}$	$f_{XP} = 24 \text{ MHz}$	$f_{XP} = 16 \text{ MHz}$	$f_{XP} = 10 \text{ MHz}$
0	1	0	0	0	$2^{18}/f_{XP}$	8.2 ms	10.9 ms	16.4 ms	26.2 ms
0	1	0	0	1	$2^{19}/f_{XP}$	16.4 ms	21.8 ms	32.8 ms	52.4 ms
0	1	0	1	0	$2^{20}/f_{XP}$	32.8 ms	43.7 ms	65.5 ms	104.9 ms
0	1	0	1	1	$2^{21}/f_{XP}$	65.5 ms	87.4 ms	131.1 ms	209.7 ms
0	1	1	0	0	$2^{22}/f_{XP}$	131.1 ms	174.8 ms	262.1 ms	419.4 ms
0	1	1	0	1	$2^{23}/f_{XP}$	262.1 ms	349.5 ms	524.3 ms	838.9 ms
0	1	1	1	0	$2^{24}/f_{XP}$	524.3 ms	699.1 ms	1048.6 ms	1677.7 ms
0	1	1	1	1	$2^{25}/f_{XP}$	1048.6 ms	1398.1 ms	2097.2 ms	3355.4 ms
						$f_{XT} = 32.768 \text{ kHz}$			
1	x	0	0	0	$2^9/f_{XT}$	15.625 ms			
1	x	0	0	1	$2^{10}/f_{XT}$	31.25 ms			
1	x	0	1	0	$2^{11}/f_{XT}$	62.5 ms			
1	x	0	1	1	$2^{12}/f_{XT}$	125 ms			
1	x	1	0	0	$2^{13}/f_{XT}$	250 ms			
1	x	1	0	1	$2^{14}/f_{XT}$	500 ms			
1	x	1	1	0	$2^{15}/f_{XT}$	1000 ms			
1	x	1	1	1	$2^{16}/f_{XT}$	2000 ms			

**Caution** When the WDTMD1 bit of the option byte 000007AH (see CHAPTER 33 OPTION BYTE FUNCTION) is set to 1, the clock is fixed to the internal oscillation clock ( $f_R$ ) ( $2^{12}/f_R$  to  $2^{19}/f_R$  selectable).

**Remark**  $f_R$ : Internal oscillation clock frequency  
 $f_{XP}$ : Peripheral clock frequency (prescaler 1 input clock frequency)  
 In clock mode 1,  $f_{XP} = f_{XX}$   
 In clock mode 2,  $f_{XP} = f_{XMPLL}/2$  (14.64 to 16 MHz)  
 In clock mode 3,  $f_{XP} = f_{XMPLL}$  (29.28 to 32 MHz)  
 In clock mode 4,  $f_{XP} = f_{XMPLL}/2$  (20.88 to 24 MHz)  
 $f_{XX}$ : Main clock frequency  
 $f_{XMPLL}$ : PLL output clock frequency for peripheral clock  
 $f_{XT}$ : Subclock frequency

**(2) Watchdog timer enable register (WDTE)**

The counter of watchdog timer 2 is cleared and counting restarted by writing “ACH” to the WDTE register.

The WDTE register can be read or written in 8-bit units.

Reset sets this register to 9AH.

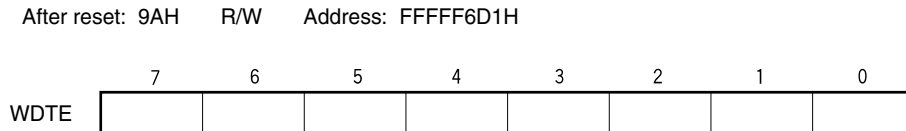

- Cautions**
1. When a value other than “ACH” is written to the WDTE register, an overflow signal is forcibly output.
  2. When a 1-bit memory manipulation instruction is executed for the WDTE register, an overflow signal is forcibly output.
  3. To intentionally generate an overflow signal, write to the WDTM2 register only twice or write a value other than “ACH” to the WDTE register once.  
However, when the watchdog timer 2 is set to stop operation, an overflow signal is not generated even if data is written to the WDTM2 register only twice, or a value other than “ACH” is written to the WDTE register only once.
  4. The read value of the WDTE register is “9AH” (which differs from written value “ACH”).

## 11.4 Operation

Watchdog timer 2 automatically starts in the reset mode following reset release.

The WDTM2 register can be written to only once following reset using byte access. To use watchdog timer 2, write the operation mode and the interval time to the WDTM2 register using an 8-bit memory manipulation instruction. After this, the operation of watchdog timer 2 cannot be stopped.

The WDCS24 to WDCS20 bits of the WDTM2 register are used to select the watchdog timer 2 loop detection time interval.

Writing ACH to the WDTE register clears the counter of watchdog timer 2 and starts the count operation again. After the count operation has started, write ACH to WDTE within the loop detection time interval.

If the time interval expires without ACH being written to the WDTE register, a reset signal (WDT2RES) or a non-maskable interrupt request signal (INTWDT2) is generated, depending on the set values of the WDM21 and WDTM2.WDM20 bits.

When the WDTM2.WDM21 bit is set to 1 (reset mode), if a WDT overflow occurs during oscillation stabilization after a reset or standby is released, no internal reset will occur and the CPU clock will switch to the internal oscillation clock.

To not use watchdog timer 2, write 00H to the WDTM2 register.

For the non-maskable interrupt servicing while the non-maskable interrupt request mode is set, see **24.2.2 (2) INTWDT2 signal**.

When the WDTMD1 bit of the option byte 0000007AH (see **CHAPTER 33 OPTION BYTE FUNCTION**) is set to 1, the operation mode of watchdog timer 2 can be fixed to reset mode ( $2^{12}/f_R$  to  $2^{19}/f_R$  selectable) and the source clock can be fixed to internal oscillation clock. However, when the WDTMD1 bit of the option byte 0000007AH is set to 1, watchdog timer 2 cannot be stopped other than be reset.

## CHAPTER 12 REAL-TIME OUTPUT FUNCTION (RTO)

### 12.1 Function

The real-time output function transfers preset data to the RTBLn and RTBHn registers, and then transfers this data by hardware to an external device via the output latches, upon occurrence of a timer interrupt. The pins through which the data is output to an external device constitute a port called the real-time output function (RTO).

Because RTO can output signals without jitter, it is suitable for controlling a stepper motor.

In the V850E/SJ3-H and V850E/SK3-H, two 6-bit real-time output port channels are provided.

The real-time output port can be set to the port mode or real-time output port mode in 1-bit units.

**Remark** n = 0, 1

## 12.2 Configuration

The block diagram of RTO is shown below.

**Figure 12-1. Block Diagram of RTO**

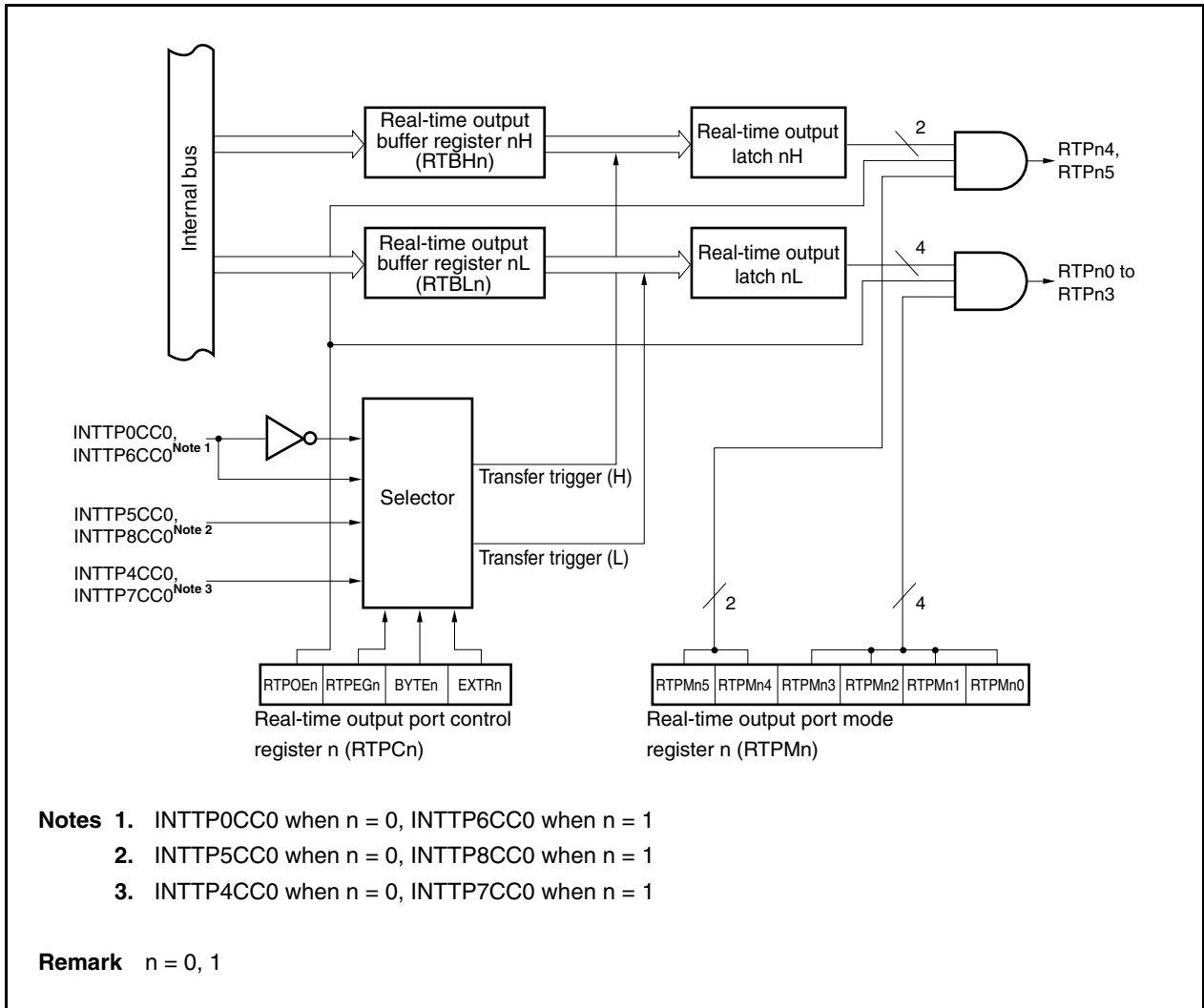

RTO consists of the following hardware.

**Table 12-1. Configuration of RTO**

Item	Configuration
Registers	Real-time output buffer registers nL, nH (RTBLn, RTBHn)
Control registers	Real-time output port mode register n (RTPMn) Real-time output port control register n (RTPCn)

**(1) Real-time output buffer registers nL, nH (RTBLn, RTBHn)**

The RTBLn and RTBHn registers are 4-bit registers that hold preset output data.

These registers are mapped to independent addresses in the peripheral I/O register area.

These registers can be read or written in 8-bit or 1-bit units.

Reset sets these registers to 00H.

If an operation mode of 4 bits × 1 channel or 2 bits × 1 channel is specified (RTPCn.BYTE<sub>n</sub> bit = 0), data can be individually set to the RTBLn and RTBHn registers. The data of both these registers can be read at once by specifying the address of either of these registers.

If an operation mode of 6 bits × 1 channel is specified (BYTE<sub>n</sub> bit = 1), 8-bit data can be set to both the RTBLn and RTBHn registers by writing the data to either of these registers. Moreover, the data of both these registers can be read at once by specifying the address of either of these registers.

Table 12-2 shows the operation when the RTBLn and RTBHn registers are manipulated.

After reset: 00H    R/W    Address: RTBL0 FFFFF6E0H, RTBH0 FFFFF6E2H,  
RTBL1 FFFFF6F0H, RTBH1 FFFFF6F2H

	7	6	5	4	3	2	1	0
RTBLn	-----				RTBLn3	RTBLn2	RTBLn1	RTBLn0
RTBHn	0	0	RTBHn5	RTBHn4	-----			

**Cautions**

1. When writing to bits 6 and 7 of the RTBHn register, always write 0.
2. Accessing the RTBLn and RTBHn registers is prohibited in the following statuses. For details, refer to 3.4.9 (2) Accessing specific on-chip peripheral I/O registers.
  - When the CPU operates with the subclock and the main clock oscillation is stopped
  - When the CPU operates with the internal oscillation clock

**Remark**    n = 0, 1

**Table 12-2. Operation During Manipulation of RTBLn and RTBHn Registers**

Operation Mode	Register to Be Manipulated	Read		Write <sup>Note</sup>	
		Higher 4 Bits	Lower 4 Bits	Higher 4 Bits	Lower 4 Bits
4 bits × 1 channel, 2 bits × 1 channel	RTBLn	RTBHn	RTBLn	Invalid	RTBLn
	RTBHn	RTBHn	RTBLn	RTBHn	Invalid
6 bits × 1 channel	RTBLn	RTBHn	RTBLn	RTBHn	RTBLn
	RTBHn	RTBHn	RTBLn	RTBHn	RTBLn

**Note** After setting the real-time output port, set output data to the RTBLn and RTBHn registers by the time a real-time output trigger is generated.



### 12.3 Registers

RTO is controlled using the following two registers.

- Real-time output port mode register n (RTPMn)
- Real-time output port control register n (RTPCn)

#### (1) Real-time output port mode register n (RTPMn)

The RTPMn register selects the real-time output port mode or port mode in 1-bit units.

This register can be read or written in 8-bit or 1-bit units.

Reset sets this register to 00H.

After reset: 00H    R/W    Address: RTPM0 FFFFF6E4H, RTPM1 FFFFF6F4H

	7	6	5	4	3	2	1	0
RTPMn (n = 0, 1)	0	0	RTPMn5	RTPMn4	RTPMn3	RTPMn2	RTPMn1	RTPMn0

RTPMnm	Control of real-time output port (m = 0 to 5)
0	Real-time output disabled
1	Real-time output enabled

**Cautions**

1. By enabling the real-time output operation (RTPCn.RTPOEn bit = 1), the bits enabled to real-time output among the RTPn0 to RTPn5 signals perform real-time output, and the bits set to port mode output 0.
2. If real-time output is disabled (RTPOEn bit = 0), the real-time output pins (RTPn0 to RTPn5) all output 0, regardless of the RTPMn register setting.
3. In order to use this register as the real-time output pins (RTPn0 to RTPn5), set these pins as real-time output port pins using the PMC and PFC registers.
4. Be sure to set bits 6 and 7 to "0".

**(2) Real-time output port control register n (RTPCn)**

The RTPCn register is a register that sets the operation mode and output trigger of the real-time output port. The relationship between the operation mode and output trigger of the real-time output port is as shown in Tables 12-3 and 12-4.

This register can be read or written in 8-bit or 1-bit units.

Reset sets this register to 00H.

After reset: 00H    R/W    Address: RTPC0 FFFFF6E5H, RTPC1 FFFFF6F5H

<7>	6	5	4	3	2	1	0
RTPCn (n = 0, 1)	RTPOEn	RTPEGn	BYTEn	EXTRn	0	0	0

RTPOEn	Control of real-time output operation
0	Disables operation <sup>Note 1</sup>
1	Enables operation

RTPEGn	Valid edge of INTTPaCC0 (n = 0, a = 0, 4, 5) and INTTPbCC0 (n = 1, b = 6 to 8) signals
0	Falling edge <sup>Note 2</sup>
1	Rising edge

BYTEn	Specification of channel configuration for real-time output
0	4 bits × 1 channel, 2 bits × 1 channel
1	6 bits × 1 channel

**Notes**

1. When the real-time output operation is disabled (RTPOEn bit = 0), all the bits of the real-time output signals (RTPn0 to RTPn5) output “0”.
2. The INTTP0CC0 and INTTP6CC0 signals are output for 1 clock of the count clock selected by TMP0 or TMP6.

**Caution** Set the RTPEGn, BYTEn, and EXTRn bits only when RTPOEn bit = 0.

**Table 12-3. Operation Modes and Output Triggers of Real-Time Output Port (n = 0)**

BYTE0	EXTR0	Operation Mode	RTBH0 (RTP04, RTP05)	RTBL0 (RTP00 to RTP03)
0	0	4 bits × 1 channel,	INTTP5CC0	INTTP4CC0
	1	2 bits × 1 channel	INTTP4CC0	INTTP0CC0
1	0	6 bits × 1 channel	INTTP4CC0	
	1		INTTP0CC0	

**Table 12-4. Operation Modes and Output Triggers of Real-Time Output Port (n = 1)**

BYTE1	EXTR1	Operation Mode	RTBH1 (RTP14, RTP15)	RTBL1 (RTP10 to RTP13)
0	0	4 bits × 1 channel,	INTTP8CC0	INTTP7CC0
	1	2 bits × 1 channel	INTTP7CC0	INTTP6CC0
1	0	6 bits × 1 channel	INTTP7CC0	
	1		INTTP6CC0	

## 12.4 Operation

If the real-time output operation is enabled by setting the RTPCn.RTPOEn bit to 1, the data of the RTBHn and RTBLn registers is transferred to the real-time output latch in synchronization with the generation of the selected transfer trigger (set by the RTPCn.EXTRn and RTPCn.BYTEn bits). Of the transferred data, only the data of the bits for which real-time output is enabled by the RTPMn register is output from the RTPn0 to RTPn5 bits. The bits for which real-time output is disabled by the RTPMn register output 0.

If the real-time output operation is disabled by clearing the RTPOEn bit to 0, the RTPn0 to RTPn5 signals output 0 regardless of the setting of the RTPMn register.

**Figure 12-2. Example of Operation Timing of RTO0 (When EXTR0 Bit = 0, BYTE0 Bit = 0)**

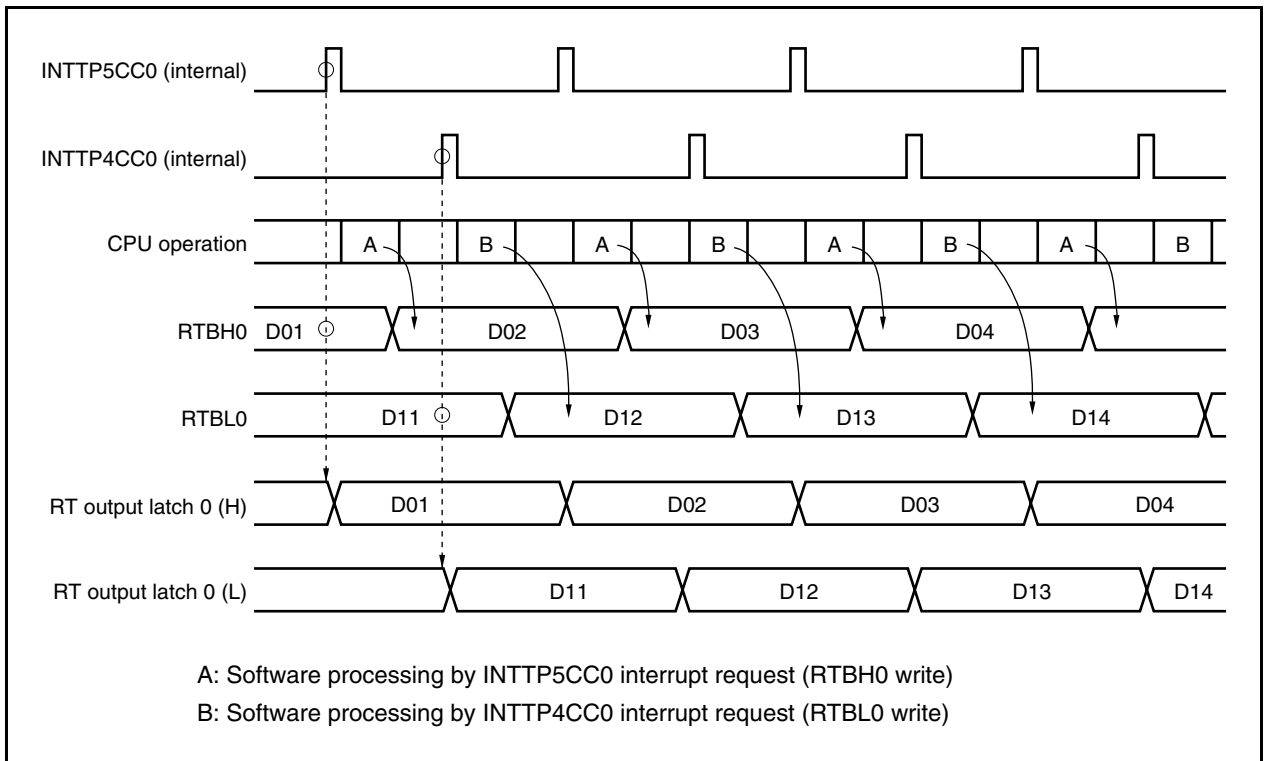

**Remark** For the operation during standby, see **CHAPTER 26 STANDBY FUNCTION**.

## 12.5 Usage

- (1) Disable real-time output.  
Clear the RTPCn.RTPOEn bit to 0.
- (2) Perform initialization as follows.
  - When  $n = 0$ , set the alternate-function pins of port 5  
Set the PFC5.PFC5m bit and PFCE5.PFCE5m bit to 1, and then set the PMC5.PMC5m bit to 1 ( $m = 0$  to 5).  
When  $n = 1$ , set the alternate-function pins of port 6  
Set the PFC6.PFC6m bit and PFCE6.PFCE6m bit to 0, and then set the PMC6.PMC6m bit to 1.
  - Specify the real-time output port mode or port mode in 1-bit units.  
Set the RTPMn register.
  - Channel configuration: Select the trigger and valid edge.  
Set the RTPCn.EXTRn, RTPCn.BYTEEn, and RTPCn.RTPEGn bits.
  - Set the initial values to the RTBHn and RTBLn registers<sup>Note 1</sup>.
- (3) Enable real-time output.  
Set the RTPOEn bit = 1.
- (4) Set the next output value to the RTBHn and RTBLn registers by the time the selected transfer trigger is generated<sup>Note 2</sup>.
- (5) Set the next real-time output value to the RTBHn and RTBLn registers via interrupt servicing corresponding to the selected trigger.

- Notes**
1. If the RTBHn and RTBLn registers are written when the RTPOEn bit = 0, that value is transferred to real-time output latches nH and nL, respectively.
  2. Even if the RTBHn and RTBLn registers are written when the RTPOEn bit = 1, data is not transferred to real-time output latches nH and nL.

## 12.6 Cautions

- (1) Prevent the following conflicts by software.
  - Conflict between real-time output disable/enable switching (RTPOEn bit) and selected real-time output trigger.
  - Conflict between writing to the RTBHn and RTBLn registers in the real-time output enabled status and the selected real-time output trigger.
- (2) Before performing initialization, disable real-time output (RTPOEn bit = 0).
- (3) Once real-time output has been disabled (RTPOEn bit = 0), be sure to initialize the RTBHn and RTBLn registers before enabling real-time output again (RTPOEn bit = 0 → 1).

## CHAPTER 13 A/D CONVERTER

### 13.1 Overview

The A/D converter converts analog input signals into digital values, has a resolution of 10 bits, and can handle 16 analog input signal channels (ANI0 to ANI15).

The A/D converter has the following features.

- 10-bit resolution
- 16 channels
- Successive approximation method
- Operating voltage:  $AV_{REF0} = 3.0$  to  $3.6$  V
- Analog input voltage: 0 V to  $AV_{REF0}$
- The following functions are provided as operation modes.
  - Continuous select mode
  - Continuous scan mode
  - One-shot select mode
  - One-shot scan mode
- The following functions are provided as trigger modes.
  - Software trigger mode
  - External trigger mode (external, 1)
  - Timer trigger mode
- Power-fail monitor function (conversion result compare function)

### 13.2 Functions

#### (1) 10-bit resolution A/D conversion

An analog input channel is selected from ANI0 to ANI15, and an A/D conversion operation is repeated at a resolution of 10 bits. Each time A/D conversion has been completed, an interrupt request signal (INTAD) is generated.

#### (2) Power-fail detection function

This function is used to detect a drop in the battery voltage. The result of A/D conversion (the value of the ADA0CRnH register) is compared with the value of the ADA0PFT register, and the INTAD signal is generated only when a specified comparison condition is satisfied ( $n = 0$  to 15).

### 13.3 Configuration

The block diagram of the A/D converter is shown below.

**Figure 13-1. Block Diagram of A/D Converter**

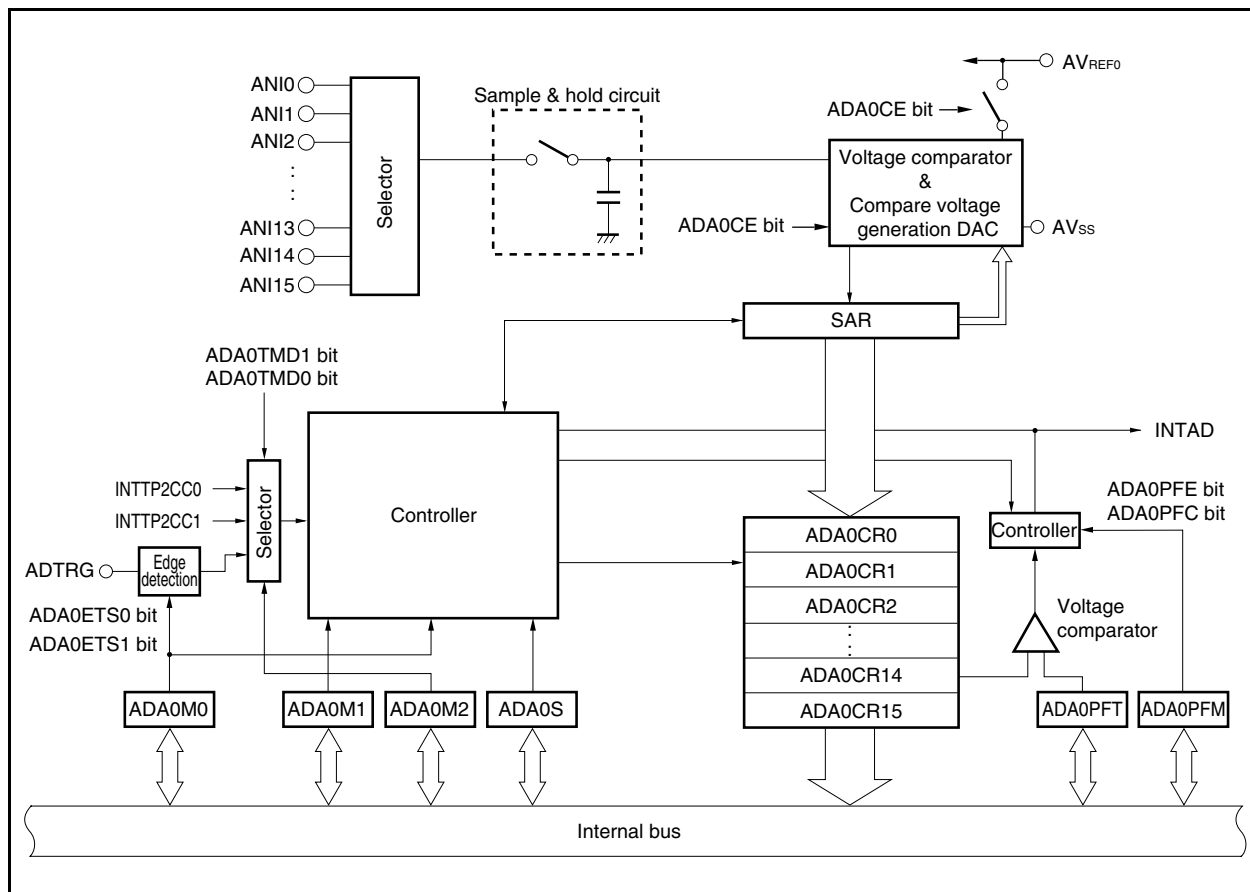

The A/D converter includes the following hardware.

**Table 13-1. Configuration of A/D Converter**

Item	Configuration
Analog inputs	16 channels (ANI0 to ANI15 pins)
Registers	Successive approximation register (SAR) A/D conversion result registers 0 to 15 (ADA0CR0 to ADA0CR15) A/D conversion result registers 0H to 15H (ADCR0H to ADCR15H): Only higher 8 bits can be read
Control registers	A/D converter mode registers 0 to 2 (ADA0M0 to ADA0M2) A/D converter channel specification register (ADA0S) Power fail compare mode register (ADA0PFM) Power fail compare threshold value register (ADA0PFT)

**(1) Successive approximation register (SAR)**

The SAR register compares the voltage value of the analog input signal with the output voltage of the compare voltage generation DAC (compare voltage), and holds the comparison result starting from the most significant bit (MSB).

When the comparison result has been held down to the least significant bit (LSB) (i.e., when A/D conversion is complete), the contents of the SAR register are transferred to the ADA0CRn register.

**Remark** n = 0 to 15

**(2) A/D conversion result register n (ADA0CRn), A/D conversion result register nH (ADA0CRnH)**

The ADA0CRn register is a 16-bit register that stores the A/D conversion result. ADA0ARn consist of 16 registers and the A/D conversion result is stored in the 10 higher bits of the AD0CRn register corresponding to analog input. (The lower 6 bits are fixed to 0.)

**(3) A/D converter mode register 0 (ADA0M0)**

This register specifies the operation mode and controls the conversion operation by the A/D converter.

**(4) A/D converter mode register 1 (ADA0M1)**

This register sets the conversion time of the analog input signal to be converted.

**(5) A/D converter mode register 2 (ADA0M2)**

This register sets the hardware trigger mode.

**(6) A/D converter channel specification register (ADA0S)**

This register sets the input port that inputs the analog voltage to be converted.

**(7) Power-fail compare mode register (ADA0PFM)**

This register sets the power-fail monitor mode.

**(8) Power-fail compare threshold value register (ADA0PFT)**

The ADA0PFT register sets a threshold value that is compared with the value of A/D conversion result register nH (ADA0CRnH). The 8-bit data set to the ADA0PFT register is compared with the higher 8 bits of the A/D conversion result register (ADA0CRnH).

**(9) Controller**

The controller compares the result of the A/D conversion (the value of the ADA0CRnH register) with the value of the ADA0PFT register when A/D conversion is completed or when the power-fail detection function is used, and generates the INTAD signal only when a specified comparison condition is satisfied.

**(10) Sample & hold circuit**

The sample & hold circuit samples each of the analog input signals selected by the input circuit and sends the sampled data to the voltage comparator. This circuit also holds the sampled analog input signal voltage during A/D conversion.

**(11) Voltage comparator**

The voltage comparator compares a voltage value that has been sampled and held with the voltage value of the compare voltage generation DAC.

**(12) Compare voltage generation DAC**

This compare voltage generation DAC is connected between  $AV_{REF0}$  and  $AV_{SS}$  and generates a voltage for comparison with the analog input signal.

**(13) ANI0 to ANI15 pins**

These are analog input pins for the 16 A/D converter channels and are used to input analog signals to be converted into digital signals. Pins other than the one selected as the analog input by the ADA0S register can be used as input port pins.

**Caution** Make sure that the voltages input to the ANI0 to ANI15 pins do not exceed the rated values. In particular if a voltage of  $AV_{REF0}$  or higher is input to a channel, the conversion value of that channel becomes undefined, and the conversion values of the other channels may also be affected.

**(14)  $AV_{REF0}$  pin**

This is the pin used to input the reference voltage of the A/D converter. Always make the potential at this pin the same as that at the  $V_{DD}$  pin even when the A/D converter is not used. The signals input to the ANI0 to ANI15 pins are converted to digital signals based on the voltage applied between the  $AV_{REF0}$  and  $AV_{SS}$  pins.

**(15)  $AV_{SS}$  pin**

This is the ground pin of the A/D converter. Always make the potential at this pin the same as that at the  $V_{SS}$  pin even when the A/D converter is not used.



### 13.4 Registers

The A/D converter is controlled by the following registers.

- A/D converter mode registers 0, 1, 2 (ADA0M0, ADA0M1, ADA0M2)
- A/D converter channel specification register 0 (ADA0S)
- Power-fail compare mode register (ADA0PFM)

The following registers are also used.

- A/D conversion result register n (ADA0CRn)
- A/D conversion result register nH (ADA0CRnH)
- Power-fail compare threshold value register (ADA0PFT)

#### (1) A/D converter mode register 0 (ADA0M0)

The ADA0M0 register is an 8-bit register that specifies the operation mode and controls conversion operations. This register can be read or written in 8-bit or 1-bit units. However, ADA0EF bit is read-only. Reset sets this register to 00H.

**Caution** Accessing the ADA0M0 register is prohibited in the following statuses. For details, refer to 3.4.9 (2) Accessing specific on-chip peripheral I/O registers.

- When the CPU operates with the subclock and the main clock oscillation is stopped
- When the CPU operates with the internal oscillation clock

(1/2)

After reset: 00H								R/W	Address: FFFFF200H								
	<7>	6	5	4	3	2	1	<0>									
ADA0M0	ADA0CE	0	ADA0MD1	ADA0MD0	ADA0ETS1	ADA0ETS0	ADA0TMD	ADA0EF									
	ADA0CE	A/D conversion control															
	0	Stops A/D conversion															
	1	Enables A/D conversion															
	ADA0MD1	ADA0MD0	Specification of A/D converter operation mode														
	0	0	Continuous select mode														
	0	1	Continuous scan mode														
	1	0	One-shot select mode														
	1	1	One-shot scan mode														

ADA0ETS1	ADA0ETS0	Specification of external trigger (ADTRG pin) input valid edge
0	0	No edge detection
0	1	Falling edge detection
1	0	Rising edge detection
1	1	Detection of both rising and falling edges

ADA0TMD	Trigger mode specification
0	Software trigger mode
1	External trigger mode/timer trigger mode

ADA0EF	A/D converter status display
0	A/D conversion stopped
1	A/D conversion in progress

- Cautions**
- If bit 0 is written, this is ignored.
  - Changing the ADA0M1 register is prohibited while A/D conversion is enabled (ADA0CE bit = 1).
  - In the following modes, write data to the ADA0M0, ADA0M2, ADA0S, ADA0PFM, and ADA0PFT registers while A/D conversion is stopped (ADA0CE bit = 0), and then enable the A/D conversion operation (ADA0CE bit = 1).
    - Normal conversion mode
    - One-shot select mode/one-shot scan mode of high-speed conversion mode
 If data is written to the ADA0M0, ADA0M2, ADA0S, ADA0PFM, and ADA0PFT registers in any other modes during A/D conversion (ADA0EF bit = 1), the operation is performed as follows, depending on the mode.
    - In software trigger mode
      - A/D conversion is stopped and started again from the beginning.
    - In hardware trigger mode
      - A/D conversion is stopped, and the trigger standby state is set.
  - To select the external trigger mode/timer trigger mode (ADA0TMD bit = 1), set the high-speed conversion mode (ADA0M1.ADA0HS1 bit = 1). Do not input a trigger during stabilization time that is inserted once after the A/D conversion operation is enabled (ADA0CE bit = 1).
  - When not using the A/D converter, stop the operation by setting the ADA0CE bit to 0 to reduce the power consumption.

**(2) A/D converter mode register 1 (ADA0M1)**

The ADA0M1 register is an 8-bit register that specifies the conversion time.

This register can be read or written in 8-bit or 1-bit units.

Reset sets this register to 00H.

After reset: 00H    R/W    Address: FFFFF201H

	7	6	5	4	3	2	1	0
ADA0M1	ADA0HS1	0	0	0	ADA0FR3	ADA0FR2	ADA0FR1	ADA0FR0

ADA0HS1	Specification of normal conversion mode/high-speed mode (A/D conversion time)
0	Normal conversion mode
1	High-speed conversion mode

- Cautions**
1. Changing the ADA0M1 register is prohibited while A/D conversion is enabled (ADA0M0.ADA0CE bit = 1).
  2. To select the external trigger mode/timer trigger mode (ADA0M0.ADA0TMD bit = 1), set the high-speed conversion mode (ADA0M1.ADA0HS1 bit = 1). Do not input a trigger during stabilization time that is inserted only once after the A/D conversion operation is enabled (ADA0CE bit = 1).
  3. Be sure to clear bits 6 to 4 to "0".

**Remark** For A/D conversion time setting examples, see **Tables 13-2** and **13-3**.

Table 13-2. Conversion Time Selection in Normal Conversion Mode (ADA0HS1 Bit = 0)

ADA0FR3 to ADA0FR0 Bits	A/D Conversion Time						
	Stabilization Time + Conversion Time + Wait Time	$f_{XP} = 32$ MHz	$f_{XP} = 24$ MHz	$f_{XP} = 20$ MHz	$f_{XP} = 16$ MHz	$f_{XP} = 4$ MHz	Trigger Response Time
0000	$66/f_{XP} (13/f_{XP} + 26/f_{XP} + 27/f_{XP})$	Setting prohibited	Setting prohibited	Setting prohibited	Setting prohibited	16.5 $\mu$ s	$3/f_{XP}$
0001	$131/f_{XP} (26/f_{XP} + 52/f_{XP} + 53/f_{XP})$	Setting prohibited	Setting prohibited	6.55 $\mu$ s	8.19 $\mu$ s	Setting prohibited	$3/f_{XP}$
0010	$196/f_{XP} (39/f_{XP} + 78/f_{XP} + 79/f_{XP})$	Setting prohibited	8.17 $\mu$ s	9.80 $\mu$ s	12.25 $\mu$ s	Setting prohibited	$3/f_{XP}$
0011	$259/f_{XP} (50/f_{XP} + 104/f_{XP} + 105/f_{XP})$	8.09 $\mu$ s	10.79 $\mu$ s	12.95 $\mu$ s	16.19 $\mu$ s	Setting prohibited	$3/f_{XP}$
0100	$311/f_{XP} (50/f_{XP} + 130/f_{XP} + 131/f_{XP})$	9.72 $\mu$ s	12.96 $\mu$ s	15.55 $\mu$ s	19.44 $\mu$ s	Setting prohibited	$3/f_{XP}$
0101	$363/f_{XP} (50/f_{XP} + 156/f_{XP} + 157/f_{XP})$	11.34 $\mu$ s	15.13 $\mu$ s	18.15 $\mu$ s	22.69 $\mu$ s	Setting prohibited	$3/f_{XP}$
0110	$415/f_{XP} (50/f_{XP} + 182/f_{XP} + 183/f_{XP})$	12.97 $\mu$ s	17.29 $\mu$ s	20.75 $\mu$ s	Setting prohibited	Setting prohibited	$3/f_{XP}$
0111	$467/f_{XP} (50/f_{XP} + 208/f_{XP} + 209/f_{XP})$	14.59 $\mu$ s	19.46 $\mu$ s	23.35 $\mu$ s	Setting prohibited	Setting prohibited	$3/f_{XP}$
1000	$519/f_{XP} (50/f_{XP} + 234/f_{XP} + 235/f_{XP})$	16.22 $\mu$ s	21.63 $\mu$ s	Setting prohibited	Setting prohibited	Setting prohibited	$3/f_{XP}$
1001	$571/f_{XP} (50/f_{XP} + 260/f_{XP} + 261/f_{XP})$	17.84 $\mu$ s	Setting prohibited	Setting prohibited	Setting prohibited	Setting prohibited	$3/f_{XP}$
1010	$623/f_{XP} (50/f_{XP} + 286/f_{XP} + 287/f_{XP})$	19.47 $\mu$ s	Setting prohibited	Setting prohibited	Setting prohibited	Setting prohibited	$3/f_{XP}$
1011	$675/f_{XP} (50/f_{XP} + 312/f_{XP} + 313/f_{XP})$	21.09 $\mu$ s	Setting prohibited	Setting prohibited	Setting prohibited	Setting prohibited	$3/f_{XP}$
Others	Setting prohibited						

- Remarks 1.** Stabilization time: A/D converter setup time (1  $\mu$ s or longer)  
Conversion time: Actual conversion time (2.6 to 10.4  $\mu$ s)  
Wait time: Wait time inserted before the next conversion  
Trigger response time: If a software trigger, external trigger, or timer trigger is generated after the stabilization time, it is inserted before the conversion time.
- 2.**  $f_{XP}$ : Peripheral clock frequency (prescaler 1 input clock frequency).  
In clock mode 1,  $f_{XP} = f_{XX}$   
In clock mode 2,  $f_{XP} = f_{XMPLL}/2$  (14.64 to 16 MHz)  
In clock mode 3,  $f_{XP} = f_{XMPLL}$  (29.28 to 32 MHz)  
In clock mode 4,  $f_{XP} = f_{XMPLL}/2$  (20.88 to 24 MHz)  
 $f_{XX}$ : Main clock frequency  
 $f_{XMPLL}$ : PLL output clock frequency for peripheral clocks

In the normal conversion mode, the conversion is started after the stabilization time elapsed from the ADA0M0.ADA0CE bit is set to 1, and A/D conversion is performed only during the conversion time (2.6 to 10.4  $\mu$ s). Operation is stopped after the conversion ends and the A/D conversion end interrupt request signal (INTAD) is generated after the wait time is elapsed.

Because the conversion operation is stopped during the wait time, operation current can be reduced.

**Caution** Set as  $2.6 \mu\text{s} \leq \text{conversion time} \leq 10.4 \mu\text{s}$ .

Table 13-3. Conversion Time Selection in High-Speed Conversion Mode (ADA0HS1 Bit = 1)

ADA0FR3 to ADA0FR0 Bits	A/D Conversion Time						Trigger Response Time
	Conversion Time (+ Stabilization Time)	$f_{XP} = 32$ MHz	$f_{XP} = 24$ MHz	$f_{XP} = 20$ MHz	$f_{XP} = 16$ MHz	$f_{XP} = 4$ MHz	
0000	$26/f_{XP} (+ 13/f_{XP})$	Setting prohibited	Setting prohibited	Setting prohibited	Setting prohibited	$6.5 \mu\text{s}$ (+ $3.25 \mu\text{s}$ )	$3/f_{XP}$
0001	$52/f_{XP} (+ 26/f_{XP})$	Setting prohibited	Setting prohibited	$2.6 \mu\text{s}$ (+ $1.3 \mu\text{s}$ )	$3.25 \mu\text{s}$ (+ $1.625 \mu\text{s}$ )	Setting prohibited	$3/f_{XP}$
0010	$78/f_{XP} (+ 39/f_{XP})$	Setting prohibited	$3.25 \mu\text{s}$ (+ $1.625 \mu\text{s}$ )	$3.9 \mu\text{s}$ (+ $1.95 \mu\text{s}$ )	$4.875 \mu\text{s}$ (+ $2.4375 \mu\text{s}$ )	Setting prohibited	$3/f_{XP}$
0011	$104/f_{XP} (+ 50/f_{XP})$	$3.25 \mu\text{s}$ (+ $1.5625 \mu\text{s}$ )	$4.33 \mu\text{s}$ (+ $2.083 \mu\text{s}$ )	$5.2 \mu\text{s}$ (+ $2.5 \mu\text{s}$ )	$6.5 \mu\text{s}$ (+ $3.125 \mu\text{s}$ )	Setting prohibited	$3/f_{XP}$
0100	$130/f_{XP} (+ 50/f_{XP})$	$4.0625 \mu\text{s}$ (+ $1.5625 \mu\text{s}$ )	$5.42 \mu\text{s}$ (+ $2.083 \mu\text{s}$ )	$6.5 \mu\text{s}$ (+ $2.5 \mu\text{s}$ )	$8.125 \mu\text{s}$ (+ $3.125 \mu\text{s}$ )	Setting prohibited	$3/f_{XP}$
0101	$156/f_{XP} (+ 50/f_{XP})$	$4.875 \mu\text{s}$ (+ $1.5625 \mu\text{s}$ )	$6.50 \mu\text{s}$ (+ $2.083 \mu\text{s}$ )	$7.8 \mu\text{s}$ (+ $2.5 \mu\text{s}$ )	$9.75 \mu\text{s}$ (+ $3.125 \mu\text{s}$ )	Setting prohibited	$3/f_{XP}$
0110	$182/f_{XP} (+ 50/f_{XP})$	$5.6875 \mu\text{s}$ (+ $1.5625 \mu\text{s}$ )	$7.58 \mu\text{s}$ (+ $2.083 \mu\text{s}$ )	$9.1 \mu\text{s}$ (+ $2.5 \mu\text{s}$ )	Setting prohibited	Setting prohibited	$3/f_{XP}$
0111	$208/f_{XP} (+ 50/f_{XP})$	$6.5 \mu\text{s}$ (+ $1.5625 \mu\text{s}$ )	$8.67 \mu\text{s}$ (+ $2.083 \mu\text{s}$ )	$10.4 \mu\text{s}$ (+ $2.5 \mu\text{s}$ )	Setting prohibited	Setting prohibited	$3/f_{XP}$
1000	$234/f_{XP} (+ 50/f_{XP})$	$7.3125 \mu\text{s}$ (+ $1.5625 \mu\text{s}$ )	$9.75 \mu\text{s}$ (+ $2.083 \mu\text{s}$ )	Setting prohibited	Setting prohibited	Setting prohibited	$3/f_{XP}$
1001	$260/f_{XP} (+ 50/f_{XP})$	$8.125 \mu\text{s}$ (+ $1.5625 \mu\text{s}$ )	Setting prohibited	Setting prohibited	Setting prohibited	Setting prohibited	$3/f_{XP}$
1010	$286/f_{XP} (+ 50/f_{XP})$	$8.9375 \mu\text{s}$ (+ $1.5625 \mu\text{s}$ )	Setting prohibited	Setting prohibited	Setting prohibited	Setting prohibited	$3/f_{XP}$
1011	$312/f_{XP} (+ 50/f_{XP})$	$9.75 \mu\text{s}$ (+ $1.5625 \mu\text{s}$ )	Setting prohibited	Setting prohibited	Setting prohibited	Setting prohibited	$3/f_{XP}$
Others	Setting prohibited						

- Remarks**
1. Stabilization time: A/D converter setup time ( $1 \mu\text{s}$  or longer)  
 Conversion time: Actual conversion time ( $2.6$  to  $10.4 \mu\text{s}$ )  
 Trigger response time: If a software trigger, external trigger, or timer trigger is generated after the stabilization time, it is inserted before the conversion time.
  2.  $f_{XP}$ : Peripheral clock frequency (prescaler 1 input clock frequency).  
 In clock mode 1,  $f_{XP} = f_{XX}$   
 In clock mode 2,  $f_{XP} = f_{XMPLL}/2$  ( $14.64$  to  $16$  MHz)  
 In clock mode 3,  $f_{XP} = f_{XMPLL}$  ( $29.28$  to  $32$  MHz)  
 In clock mode 4,  $f_{XP} = f_{XMPLL}/2$  ( $20.88$  to  $24$  MHz)  
 $f_{XX}$ : Main clock frequency  
 $f_{XMPLL}$ : PLL output clock frequency for peripheral clocks

In the high-speed conversion mode, the conversion is started after the stabilization time elapsed from the ADA0M0.ADA0CE bit is set to 1, and A/D conversion is performed only during the conversion time ( $2.6$  to  $10.4 \mu\text{s}$ ). The A/D conversion end interrupt request signal (INTAD) is generated immediately after the conversion ends.

In continuous conversion mode, the stabilization time is inserted only before the first conversion, and not inserted after the second conversion (the A/D converter remains running).

**Caution** Set as  $2.6 \mu\text{s} \leq \text{conversion time} \leq 10.4 \mu\text{s}$ .

**(3) A/D converter mode register 2 (ADA0M2)**

The ADA0M2 register specifies the hardware trigger mode.

This register can be read or written in 8-bit or 1-bit units.

Reset sets this register to 00H.

After reset: 00H    R/W    Address: FFFFF203H

	7	6	5	4	3	2	1	0
ADA0M2	0	0	0	0	0	0	ADA0TMD1	ADA0TMD0

ADA0TMD1	ADA0TMD0	Specification of hardware trigger mode
0	0	External trigger mode (when ADTRG pin valid edge detected)
0	1	Timer trigger mode 0 (when INTTP2CC0 interrupt request generated)
1	0	Timer trigger mode 1 (when INTTP2CC1 interrupt request generated)
1	1	Setting prohibited

**Cautions 1.** In the following modes, write data to the ADA0M2 register while A/D conversion is stopped (ADA0M0.ADA0CE bit = 0), and then enable the A/D conversion operation (ADA0CE bit = 1).

- Normal conversion mode
- One-shot select mode/one-shot scan mode of the high-speed conversion mode

**2.** Be sure to clear bits 7 to 2 to “0”.

**(4) A/D converter channel specification register (ADA0S)**

The ADA0S register specifies the pin that inputs the analog voltage to be converted into a digital signal.

This register can be read or written in 8-bit or 1-bit units.

Reset sets this register to 00H.

After reset: 00H R/W Address: FFFFF202H

	7	6	5	4	3	2	1	0
ADA0S	0	0	0	0	ADA0S3	ADA0S2	ADA0S1	ADA0S0

ADA0S3	ADA0S2	ADA0S1	ADA0S0	Select mode	Scan mode
0	0	0	0	ANI0	ANI0
0	0	0	1	ANI1	ANI0, ANI1
0	0	1	0	ANI2	ANI0 to ANI2
0	0	1	1	ANI3	ANI0 to ANI3
0	1	0	0	ANI4	ANI0 to ANI4
0	1	0	1	ANI5	ANI0 to ANI5
0	1	1	0	ANI6	ANI0 to ANI6
0	1	1	1	ANI7	ANI0 to ANI7
1	0	0	0	ANI8	ANI0 to ANI8
1	0	0	1	ANI9	ANI0 to ANI9
1	0	1	0	ANI10	ANI0 to ANI10
1	0	1	1	ANI11	ANI0 to ANI11
1	1	0	0	ANI12	ANI0 to ANI12
1	1	0	1	ANI13	ANI0 to ANI13
1	1	1	0	ANI14	ANI0 to ANI14
1	1	1	1	ANI15	ANI0 to ANI15

**Cautions 1.** In the following modes, write data to the ADA0S register while A/D conversion is stopped (ADA0M0.ADA0CE bit = 0), and then enable the A/D conversion operation (ADA0CE bit = 1).

- Normal conversion mode
- One-shot select mode/one-shot scan mode of the high-speed conversion mode

**2.** Be sure to clear bits 7 to 4 to “0”.

**(5) A/D conversion result registers n, nH (ADA0CRn, ADA0CRnH)**

The ADA0CRn and ADA0CRnH registers store the A/D conversion results.

These registers are read-only, in 16-bit or 8-bit units. However, specify the ADA0CRn register for 16-bit access and the ADA0CRnH register for 8-bit access. The 10 bits of the conversion result are read from the higher 10 bits of the ADA0CRn register, and 0 is read from the lower 6 bits. The higher 8 bits of the conversion result are read from the ADA0CRnH register.

**Caution** Accessing the ADA0CRn and ADA0CRnH registers is prohibited in the following statuses.

For details, refer to 3.4.9 (2) Accessing specific on-chip peripheral I/O registers.

- When the CPU operates with the subclock and the main clock oscillation is stopped
- When the CPU operates with the internal oscillation clock

After reset: Undefined R Address: ADA0CR0 FFFFFFF210H, ADA0CR1 FFFFFFF212H,  
 ADA0CR2 FFFFFFF214H, ADA0CR3 FFFFFFF216H,  
 ADA0CR4 FFFFFFF218H, ADA0CR5 FFFFFFF21AH,  
 ADA0CR6 FFFFFFF21CH, ADA0CR7 FFFFFFF21EH,  
 ADA0CR8 FFFFFFF220H, ADA0CR9 FFFFFFF222H,  
 ADA0CR10 FFFFFFF224H, ADA0CR11 FFFFFFF226H,  
 ADA0CR12 FFFFFFF228H, ADA0CR13 FFFFFFF22AH,  
 ADA0CR14 FFFFFFF22CH, ADA0CR15 FFFFFFF22EH

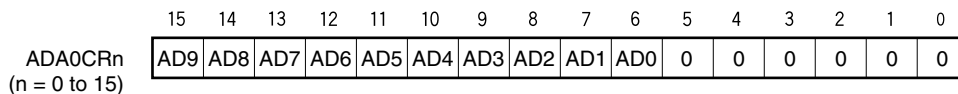

After reset: Undefined R Address: ADA0CR0H FFFFFFF211H, ADA0CR1H FFFFFFF213H,  
 ADA0CR2H FFFFFFF215H, ADA0CR3H FFFFFFF217H,  
 ADA0CR4H FFFFFFF219H, ADA0CR5H FFFFFFF21BH,  
 ADA0CR6H FFFFFFF21DH, ADA0CR7H FFFFFFF21FH,  
 ADA0CR8H FFFFFFF221H, ADA0CR9H FFFFFFF223H,  
 ADA0CR10H FFFFFFF225H, ADA0CR11H FFFFFFF227H,  
 ADA0CR12H FFFFFFF229H, ADA0CR13H FFFFFFF22BH,  
 ADA0CR14H FFFFFFF22DH, ADA0CR15H FFFFFFF22FH

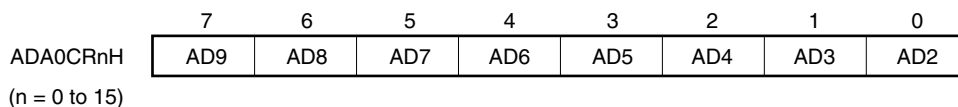

**Caution** A write operation to the ADA0M0 and ADA0S registers may cause the contents of the ADA0CRn register to become undefined. After the conversion, read the conversion result before writing to the ADA0M0 and ADA0S registers. Correct conversion results may not be read if a sequence other than the above is used.



The relationship between the analog voltage input to the analog input pins (ANI0 to ANI15) and the A/D conversion result (ADA0CRn register) is as follows.

$$SAR = \text{INT} \left( \frac{V_{IN}}{AV_{REF0}} \times 1,024 + 0.5 \right)$$

$$ADA0CR^{Note} = SAR \times 64$$

Or,

$$(SAR - 0.5) \times \frac{AV_{REF0}}{1,024} \leq V_{IN} < (SAR + 0.5) \times \frac{AV_{REF0}}{1,024}$$

- INT( ): Function that returns the integer of the value in ( )
- V<sub>IN</sub>: Analog input voltage
- AV<sub>REF0</sub>: AV<sub>REF0</sub> pin voltage
- ADA0CR: Value of ADA0CRn register

**Note** The lower 6 bits of the ADA0CRn register are fixed to 0.

The following shows the relationship between the analog input voltage and the A/D conversion results.

**Figure 13-2. Relationship Between Analog Input Voltage and A/D Conversion Results**

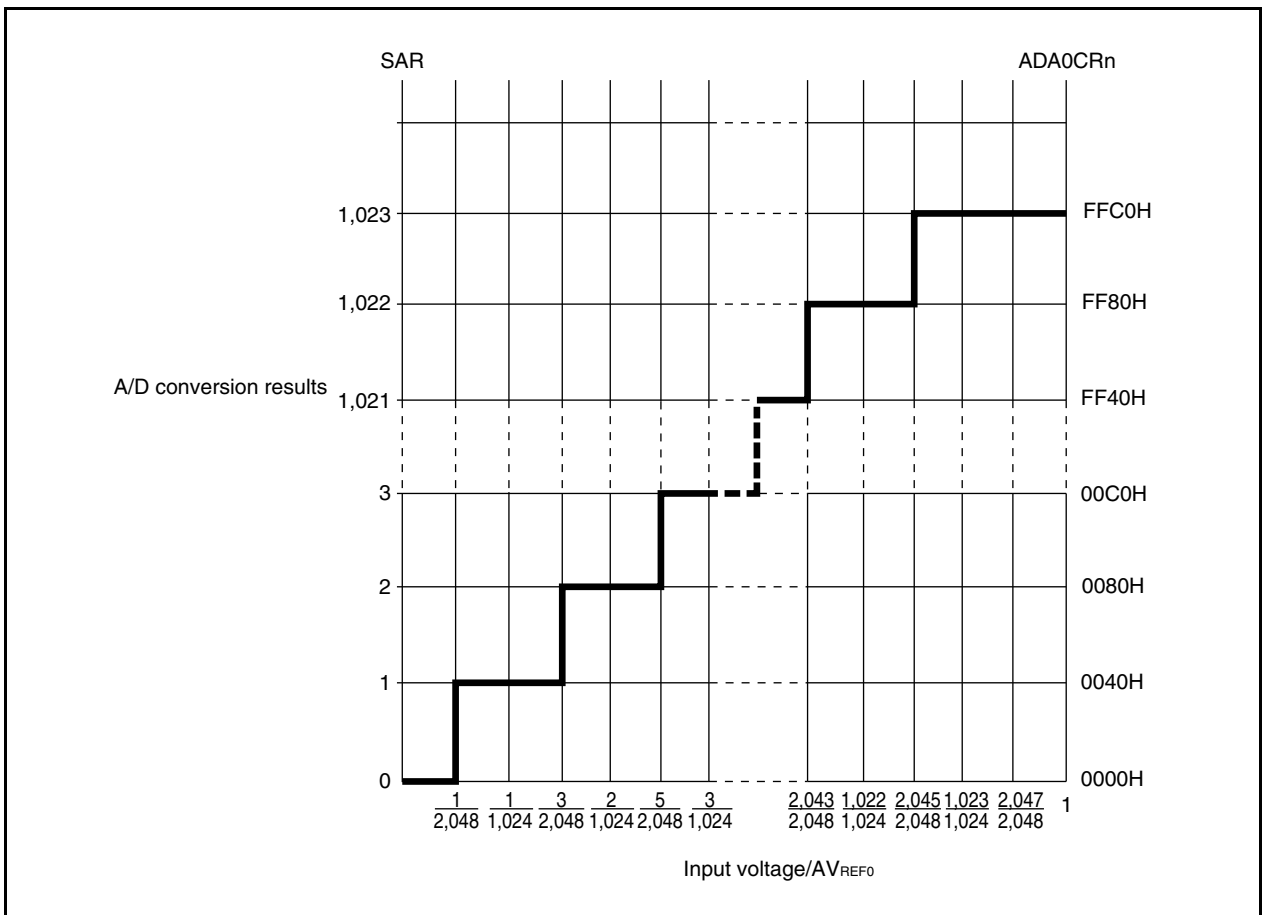

**(6) Power-fail compare mode register (ADA0PFM)**

The ADA0PFM register is an 8-bit register that sets the power-fail compare mode.

This register can be read or written in 8-bit or 1-bit units.

Reset sets this register to 00H.

After reset: 00H    R/W    Address: FFFFF204H

	<7>	6	5	4	3	2	1	0
ADA0PFM	ADA0PFE	ADA0PFC	0	0	0	0	0	0

ADA0PFE	Selection of power-fail compare enable/disable
0	Power-fail compare disabled
1	Power-fail compare enabled

ADA0PFC	Selection of power-fail compare mode
0	Generates an interrupt request signal (INTAD) when $ADA0CRnH \geq ADA0PFT$
1	Generates an interrupt request signal (INTAD) when $ADA0CRnH < ADA0PFT$

- Cautions**
- In the select mode, the 8-bit data set to the ADA0PFT register is compared with the value of the ADA0CRnH register specified by the ADA0S register. If the result matches the condition specified by the ADA0PFC bit, the conversion result is stored in the ADA0CRn register and the INTAD signal is generated. If it does not match, however, the interrupt signal is not generated.
  - In the scan mode, the 8-bit data set to the ADA0PFT register is compared with the contents of the ADA0CR0H register. If the result matches the condition specified by the ADA0PFC bit, the conversion result is stored in the ADA0CR0 register and the INTAD signal is generated. If it does not match, however, the INTAD signal is not generated. Regardless of the comparison result, the scan operation is continued and the conversion result is stored in the ADA0CRn register until the scan operation is completed. However, the INTAD signal is not generated after the scan operation has been completed.
  - In the following modes, write data to the ADA0PFM register while A/D conversion is stopped (ADA0M0.ADA0CE bit = 0), and then enable the A/D conversion operation (ADA0CE bit = 1).
    - Normal conversion mode
    - One-shot select mode/one-shot scan mode of the high-speed conversion mode
  - Be sure to set bits 0 to 5 to "0".

**(7) Power-fail compare threshold value register (ADA0PFT)**

The ADA0PFT register sets the compare value in the power-fail compare mode.

This register can be read or written in 8-bit or 1-bit units.

Reset sets this register to 00H.

After reset: 00H    R/W    Address: FFFFF205H

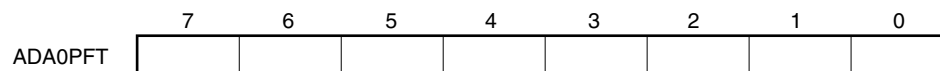

**Caution** In the following modes, write data to the ADA0PFT register while A/D conversion is stopped (ADA0M0.ADA0CE bit = 0), and then enable the A/D conversion operation (ADA0CE bit = 1).

- Normal conversion mode
- One-shot select mode/one-shot scan mode of the high-speed conversion mode

## 13.5 Operation

### 13.5.1 Basic operation

- <1> Set the operation mode, trigger mode, and conversion time for executing A/D conversion by using the ADA0M0, ADA0M1, ADA0M2, and ADA0S registers. When the ADA0M0.ADA0CE bit is set, conversion is started in the software trigger mode and the A/D converter waits for a trigger in the external or timer trigger mode.
- <2> When A/D conversion is started, the voltage input to the selected analog input channel is sampled by the sample & hold circuit.
- <3> When the sample & hold circuit samples the input channel for a specific time, it enters the hold status, and holds the input analog voltage until A/D conversion is complete.
- <4> Set bit 9 of the successive approximation register (SAR) to set the compare voltage generation DAC to  $(1/2) AV_{REF0}$ .
- <5> The voltage difference between the compare voltage generation DAC and the analog input voltage is compared by the voltage comparator. If the analog input voltage is higher than  $(1/2) AV_{REF0}$ , the MSB of the SAR register remains set. If it is lower than  $(1/2) AV_{REF0}$ , the MSB is reset.
- <6> Next, bit 8 of the SAR register is automatically set and the next comparison is started. Depending on the value of bit 9, to which a result has been already set, the compare voltage generation DAC is selected as follows.
  - Bit 9 = 1:  $(3/4) AV_{REF0}$
  - Bit 9 = 0:  $(1/4) AV_{REF0}$
 This compare voltage and the analog input voltage are compared and, depending on the result, bit 8 is manipulated as follows.  
 Analog input voltage  $\geq$  Compare voltage: Bit 8 = 1  
 Analog input voltage  $\leq$  Compare voltage: Bit 8 = 0
- <7> This comparison is continued to bit 0 of the SAR register.
- <8> When comparison of the 10 bits is complete, the valid digital result is stored in the SAR register, which is then transferred to and stored in the ADA0CRn register. After that, an A/D conversion end interrupt request signal (INTAD) is generated.
- <9> In one-shot select mode, conversion is stopped<sup>Note</sup>. In one-shot scan mode, conversion is stopped after scanning once<sup>Note</sup>. In continuous select mode, repeat steps <2> to <8> until the ADA0M0.ADA0CE bit is cleared to 0. In continuous scan mode, repeat steps <2> to <8> for each channel.

**Note** In the external trigger mode, timer trigger mode 0, or timer trigger mode 1, the trigger standby status is entered.

**Remark** The trigger standby status means the status after the stabilization time has elapsed.

13.5.2 Conversion operation timing

Figure 13-3. Conversion Operation Timing (Continuous Conversion)

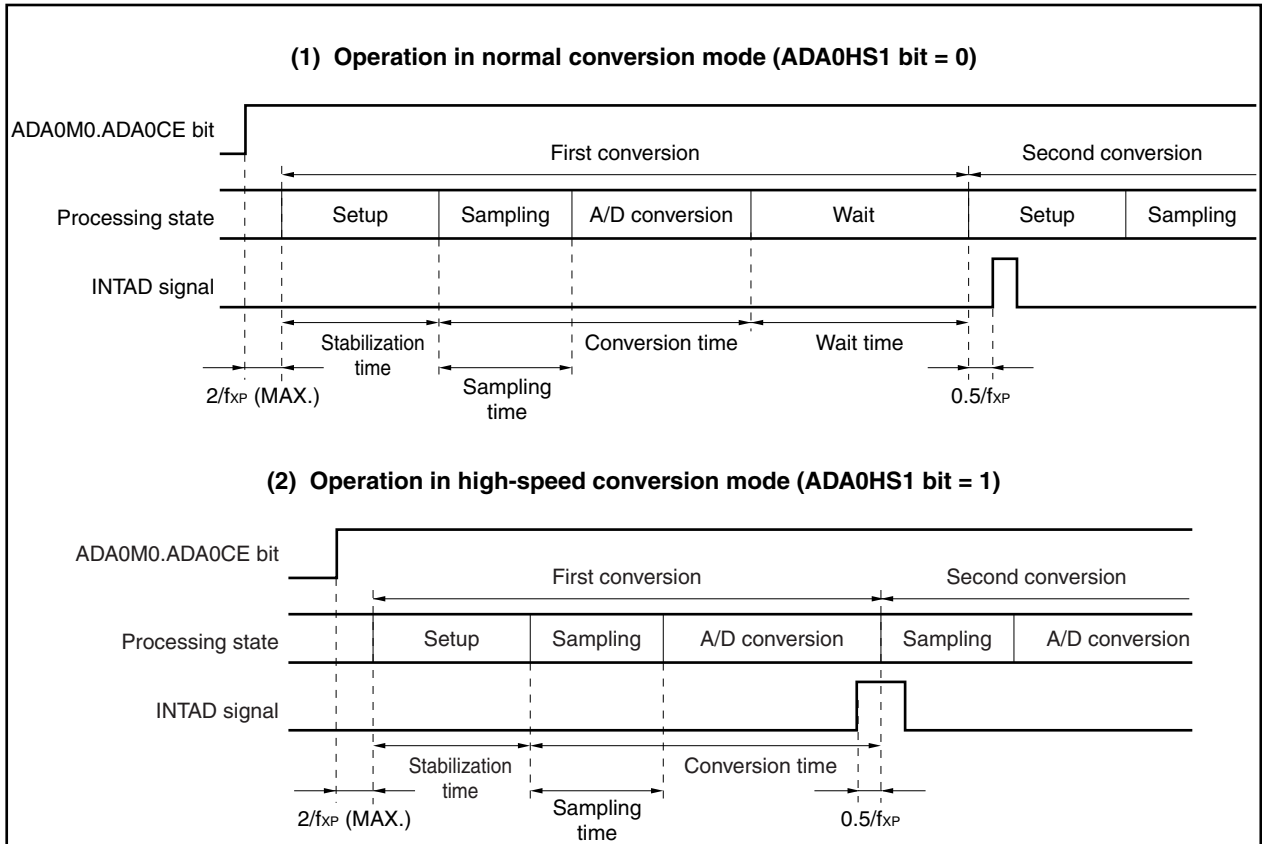

ADA0FR3 to ADA0FR0 Bits	Stabilization Time	Conversion Time (Sampling Time)	Wait Time	Trigger Response Time
0000	13/f <sub>XP</sub>	26/f <sub>XP</sub> (8/f <sub>XP</sub> )	27/f <sub>XP</sub>	3/f <sub>XP</sub>
0001	26/f <sub>XP</sub>	52/f <sub>XP</sub> (16/f <sub>XP</sub> )	53/f <sub>XP</sub>	3/f <sub>XP</sub>
0010	39/f <sub>XP</sub>	78/f <sub>XP</sub> (24/f <sub>XP</sub> )	79/f <sub>XP</sub>	3/f <sub>XP</sub>
0011	50/f <sub>XP</sub>	104/f <sub>XP</sub> (32/f <sub>XP</sub> )	105/f <sub>XP</sub>	3/f <sub>XP</sub>
0100	50/f <sub>XP</sub>	130/f <sub>XP</sub> (40/f <sub>XP</sub> )	131/f <sub>XP</sub>	3/f <sub>XP</sub>
0101	50/f <sub>XP</sub>	156/f <sub>XP</sub> (48/f <sub>XP</sub> )	157/f <sub>XP</sub>	3/f <sub>XP</sub>
0110	50/f <sub>XP</sub>	182/f <sub>XP</sub> (56/f <sub>XP</sub> )	183/f <sub>XP</sub>	3/f <sub>XP</sub>
0111	50/f <sub>XP</sub>	208/f <sub>XP</sub> (64/f <sub>XP</sub> )	209/f <sub>XP</sub>	3/f <sub>XP</sub>
1000	50/f <sub>XP</sub>	234/f <sub>XP</sub> (72/f <sub>XP</sub> )	235/f <sub>XP</sub>	3/f <sub>XP</sub>
1001	50/f <sub>XP</sub>	260/f <sub>XP</sub> (80/f <sub>XP</sub> )	261/f <sub>XP</sub>	3/f <sub>XP</sub>
1010	50/f <sub>XP</sub>	286/f <sub>XP</sub> (88/f <sub>XP</sub> )	287/f <sub>XP</sub>	3/f <sub>XP</sub>
1011	50/f <sub>XP</sub>	312/f <sub>XP</sub> (96/f <sub>XP</sub> )	313/f <sub>XP</sub>	3/f <sub>XP</sub>
Others	Setting prohibited			

- Remarks 1.** The above timings are when a trigger generates within the stabilization time. If the trigger generates after the stabilization time, the trigger response time is inserted.
- 2.** f<sub>XP</sub>: Peripheral clock frequency (prescaler 1 input clock frequency).  
See **Remark 2** in **Table 13-3** for details.

### 13.5.3 Trigger mode

The timing of starting the conversion operation is specified by setting a trigger mode. The trigger mode includes a software trigger mode and hardware trigger modes. The hardware trigger modes include timer trigger modes 0 and 1, and external trigger mode. The ADA0M0.ADA0TMD bit is used to set the trigger mode. The hardware trigger modes are set by the ADA0M2.ADA0TMD1 and ADA0M2.ADA0TMD0 bits.

#### (1) Software trigger mode

When the ADA0M0.ADA0CE bit is set to 1, the signal of the analog input pin (ANI0 to ANI15 pin) specified by the ADA0S register is converted. When conversion is complete, the result is stored in the ADA0CRn register. At the same time, the A/D conversion end interrupt request signal (INTAD) is generated.

If the operation mode specified by the ADA0M0.ADA0MD1 and ADA0M0.ADA0MD0 bits is the continuous select/scan mode, the next conversion is started, unless the ADA0CE bit is cleared to 0 after completion of the first conversion. Conversion is performed once and ends if the operation mode is the one-shot select/scan mode.

When conversion is started, the ADA0M0.ADA0EF bit is set to 1 (indicating that conversion is in progress).

If the ADA0M0, ADA0M2, ADA0S, ADA0PFM, or ADA0PFT register is written during conversion, the conversion is aborted and started again from the beginning. However, writing these registers is prohibited in the normal conversion mode and one-shot select mode/one-shot scan mode of the high-speed conversion mode.

#### (2) External trigger mode

In this mode, converting the signal of the analog input pin (ANI0 to ANI15) specified by the ADA0S register is started when an external trigger is input (to the ADTRG pin). Which edge of the external trigger is to be detected (i.e., the rising edge, falling edge, or both rising and falling edges) can be specified by using the ADA0M0.ADA0ETS1 and ADA0M0.ATA0ETS0 bits. When the ADA0CE bit is set to 1, the A/D converter waits for the trigger, and starts conversion after the external trigger has been input.

When conversion is completed, the result of conversion is stored in the ADA0CRn register, regardless of whether the continuous select, continuous scan, one-shot select, or one-shot scan mode is set as the operation mode by the ADA0MD1 and ADA0MD0 bits. At the same time, the INTAD signal is generated, and the A/D converter waits for the trigger again.

When conversion is started, the ADA0EF bit is set to 1 (indicating that conversion is in progress). While the A/D converter is waiting for the trigger, however, the ADA0EF bit is cleared to 0 (indicating that conversion is stopped). If the valid trigger is input during the conversion operation, the conversion is aborted and started again from the beginning.

If the ADA0M0, ADA0M2, ADA0S, ADA0PFM, or ADA0PFT register is written during the conversion operation, the conversion is not aborted, and the A/D converter waits for the trigger again. However, writing these registers is prohibited in the one-shot select mode/one-shot scan mode.

**Caution** To select the external trigger mode, set the high-speed conversion mode. Do not input a trigger during stabilization time that is inserted once after the A/D conversion operation is enabled (ADA0M0.ADA0CE bit = 1).

**Remark** The trigger standby status means the status after the stabilization time has elapsed.

**(3) Timer trigger mode**

In this mode, converting the signal of the analog input pin (ANI0 to ANI15) specified by the ADA0S register is started by the compare match interrupt request signal (INTTP2CC0 or INTTP2CC1) of the capture/compare register connected to the timer. The INTTP2CC0 or INTTP2CC1 signal is selected by the ADA0TMD1 and ADA0TMD0 bits, and conversion is started at the rising edge of the specified compare match interrupt request signal. When the ADA0CE bit is set to 1, the A/D converter waits for a trigger, and starts conversion when the compare match interrupt request signal of the timer is input.

When conversion is completed, regardless of whether the continuous select, continuous scan, one-shot select, or one-shot scan mode is set as the operation mode by the ADA0MD1 and ADA0MD0 bits, the result of the conversion is stored in the ADA0CRn register. At the same time, the INTAD signal is generated, and the A/D converter waits for the trigger again.

When conversion is started, the ADA0EF bit is set to 1 (indicating that conversion is in progress). While the A/D converter is waiting for the trigger, however, the ADA0EF bit is cleared to 0 (indicating that conversion is stopped). If the valid trigger is input during the conversion operation, the conversion is aborted and started again from the beginning.

If the ADA0M0, ADA0M2, ADA0S, ADA0PFM, or ADA0PFT register is written during conversion, the conversion is stopped and the A/D converter waits for the trigger again. However, writing these registers is prohibited in the one-shot select mode/one-shot scan mode.

**Caution** To select the timer trigger mode, set the high-speed conversion mode. Do not input a trigger during stabilization time that is inserted once after the A/D conversion operation is enabled (ADA0M0.ADA0CE bit = 1).

**Remark** The trigger standby status means the status after the stabilization time has elapsed.

**13.5.4 Operation mode**

Four operation modes are available as the modes in which to set the ANI0 to ANI15 pins: continuous select mode, continuous scan mode, one-shot select mode, and one-shot scan mode.

The operation mode is selected by the ADA0M0.ADA0MD1 and ADA0M0.ADA0MD0 bits.

**(1) Continuous select mode**

In this mode, the voltage of one analog input pin selected by the ADA0S register is continuously converted into a digital value.

The conversion result is stored in the ADA0CRn register corresponding to the analog input pin. In this mode, an analog input pin corresponds to an ADA0CRn register on a one-to-one basis. Each time A/D conversion is completed, the A/D conversion end interrupt request signal (INTAD) is generated. After completion of conversion, the next conversion is started, unless the ADA0M0.ADA0CE bit is cleared to 0 (n = 0 to 15).

**Figure 13-4. Timing Example of Continuous Select Mode Operation (ADA0S Register = 01H)**

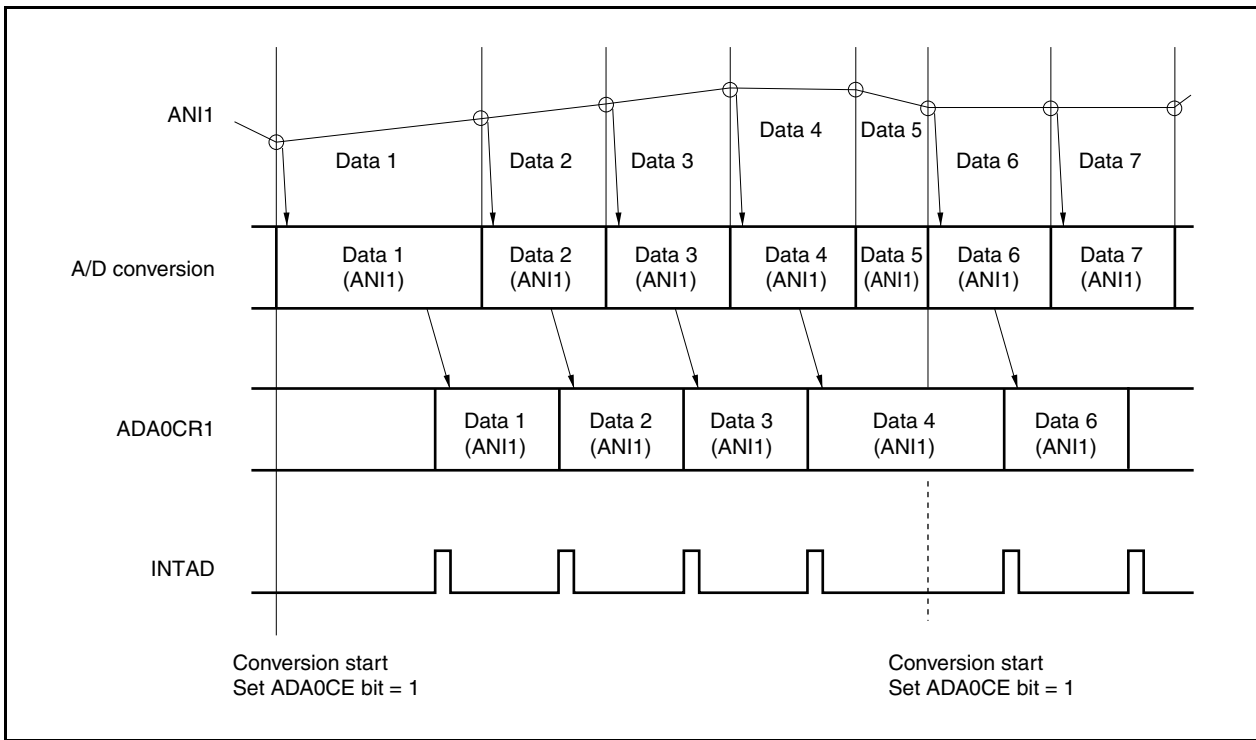

**(2) Continuous scan mode**

In this mode, analog input pins are sequentially selected, from the ANI0 pin to the pin specified by the ADA0S register, and their values are converted into digital values.

The result of each conversion is stored in the ADA0CRn register corresponding to the analog input pin. When conversion of the analog input pin specified by the ADA0S register is complete, the INTAD signal is generated, and A/D conversion is started again from the ANI0 pin, unless the ADA0CE bit is cleared to 0 (n = 0 to 15).



Figure 13-5. Timing Example of Continuous Scan Mode Operation (ADA0S Register = 03H)

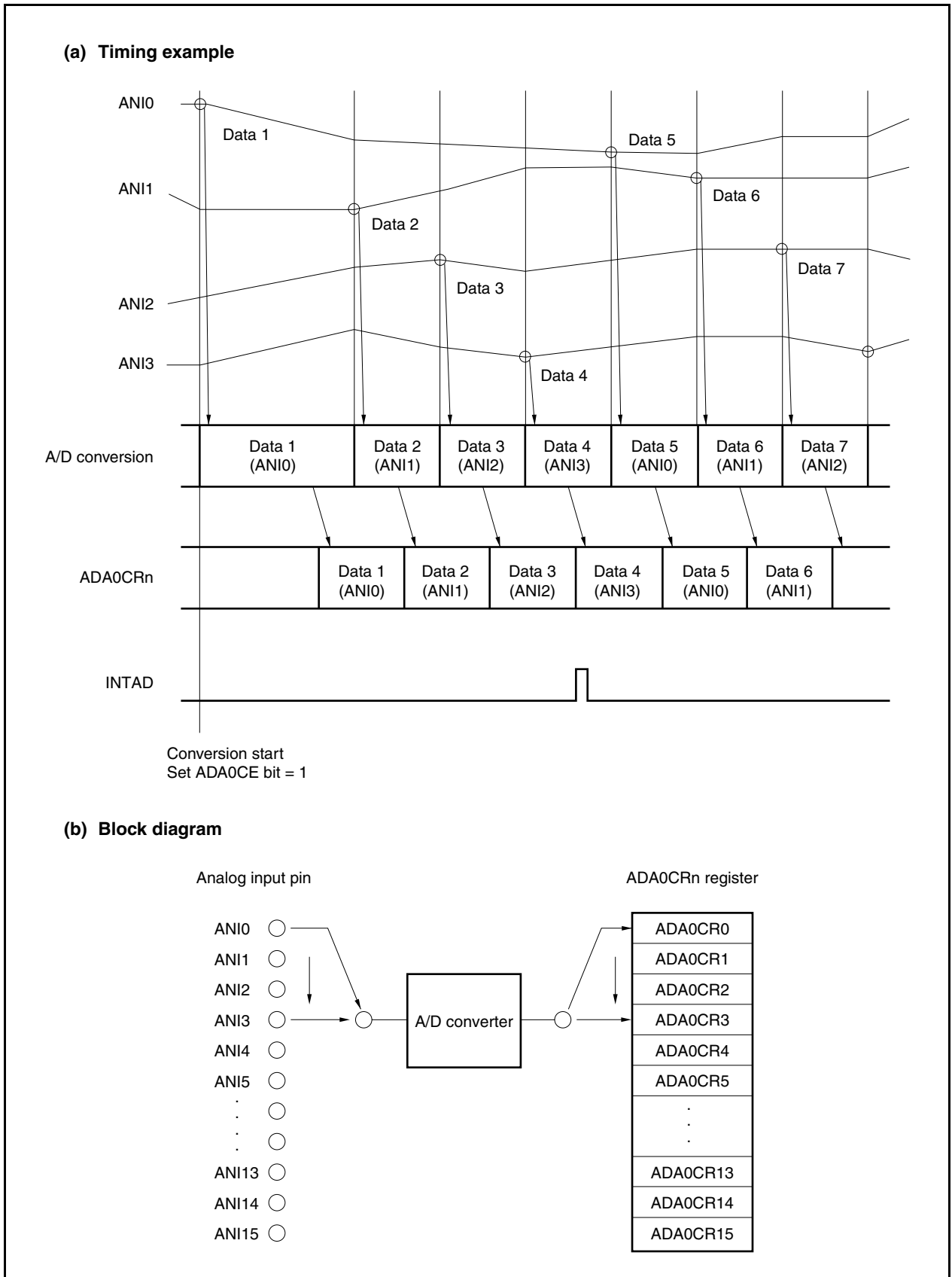

**(3) One-shot select mode**

In this mode, the voltage on the analog input pin specified by the ADA0S register is converted into a digital value only once.

The conversion result is stored in the ADA0CRn register corresponding to the analog input pin. In this mode, an analog input pin and an ADA0CRn register correspond on a one-to-one basis. When A/D conversion has been completed once, the INTAD signal is generated. The A/D conversion operation is stopped after it has been completed ( $n = 0$  to 15).

**Figure 13-6. Timing Example of One-Shot Select Mode Operation (ADA0S Register = 01H)**

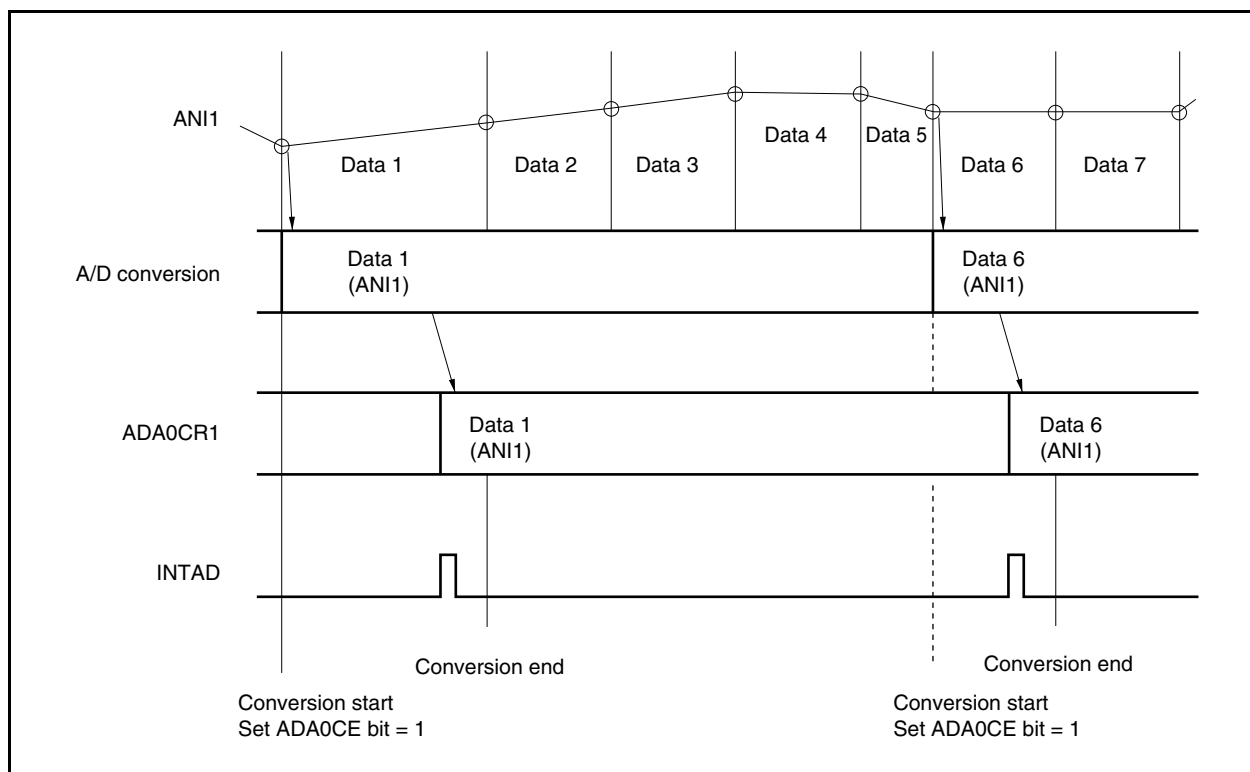
**(4) One-shot scan mode**

In this mode, analog input pins are sequentially selected, from the ANI0 pin to the pin specified by the ADA0S register, and their values are converted into digital values .

Each conversion result is stored in the ADA0CRn register corresponding to the analog input pin. When conversion of the analog input pin specified by the ADA0S register is complete, the INTAD signal is generated. A/D conversion is stopped after it has been completed ( $n = 0$  to 15).

Figure 13-7. Timing Example of One-Shot Scan Mode Operation (ADA0S Register = 03H)

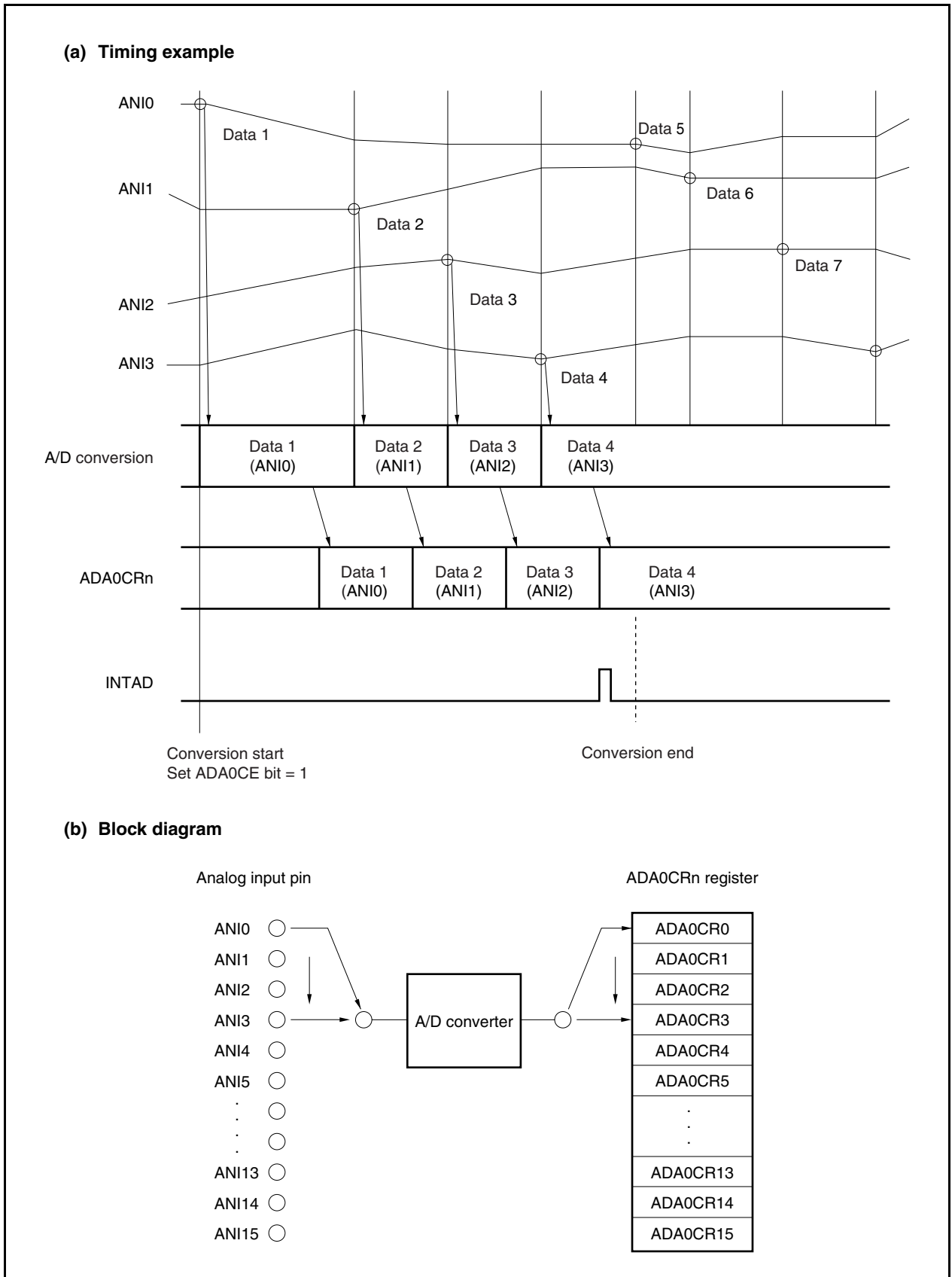

### 13.5.5 Power-fail compare mode

The A/D conversion end interrupt request signal (INTAD) can be controlled as follows by the ADA0PFM and ADA0PFT registers.

- When the ADA0PFM.ADA0PFE bit = 0, the INTAD signal is generated each time conversion is completed (normal use of the A/D converter).
- When the ADA0PFE bit = 1 and when the ADA0PFM.ADA0PFC bit = 0, the value of the ADA0CRnH register is compared with the value of the ADA0PFT register when conversion is completed, and the INTAD signal is generated only if  $ADA0CRnH \geq ADA0PFT$ .
- When the ADA0PFE bit = 1 and when the ADA0PFC bit = 1, the value of the ADA0CRnH register is compared with the value of the ADA0PFT register when conversion is completed, and the INTAD signal is generated only if  $ADA0CRnH < ADA0PFT$ .

**Remark** n = 0 to 15

In the power-fail compare mode, four modes are available as modes in which to set the ANI0 to ANI15 pins: continuous select mode, continuous scan mode, one-shot select mode, and one-shot scan mode.

**(1) Continuous select mode**

In this mode, the result of converting the voltage of the analog input pin specified by the ADA0S register is compared with the set value of the ADA0PFT register. If the result of power-fail compare matches the condition set by the ADA0PFC bit, the conversion result is stored in the ADA0CRn register, and the INTAD signal is generated. If it does not match, the conversion result is stored in the ADA0CRn register, and the INTAD signal is not generated. After completion of the first conversion, the next conversion is started, unless the ADA0M0.ADA0CE bit is cleared to 0 (n = 0 to 15).

**Figure 13-8. Timing Example of Continuous Select Mode Operation  
(When Power-Fail Comparison Is Made: ADA0S Register = 01H)**

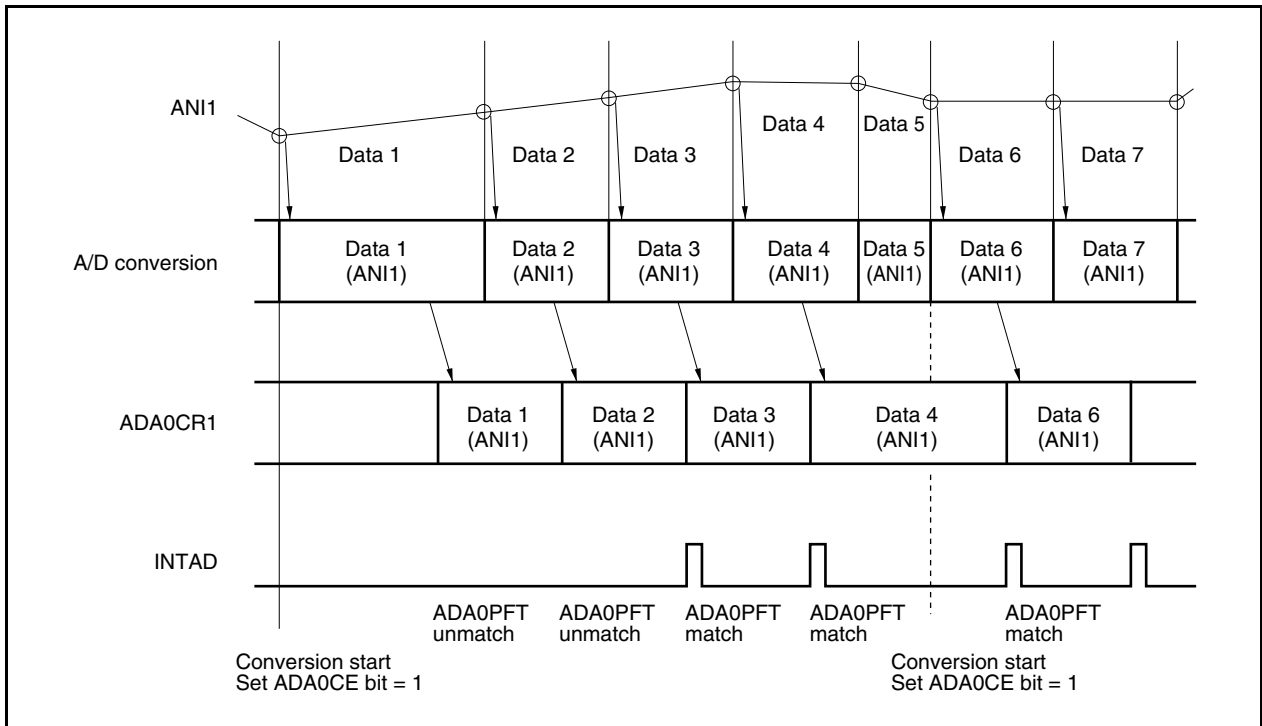
**(2) Continuous scan mode**

In this mode, the results of converting the voltages of the analog input pins sequentially selected from the ANI0 pin to the pin specified by the ADA0S register are stored, and the set value of the ADA0CR0H register of channel 0 is compared with the value of the ADA0PFT register. If the result of power-fail compare matches the condition set by the ADA0PFC bit, the conversion result is stored in the ADA0CR0 register, and the INTAD signal is generated. If it does not match, the conversion result is stored in the ADA0CR0 register, and the INTAD signal is not generated.

After the result of the first conversion has been stored in the ADA0CR0 register, the results of sequentially converting the voltages on the analog input pins up to the pin specified by the ADA0S register are continuously stored. After completion of conversion, the next conversion is started from the ANI0 pin again, unless the ADA0CE bit is cleared to 0.

**Figure 13-9. Timing Example of Continuous Scan Mode Operation  
(When Power-Fail Comparison Is Made: ADA0S Register = 03H)**

**(a) Timing example**

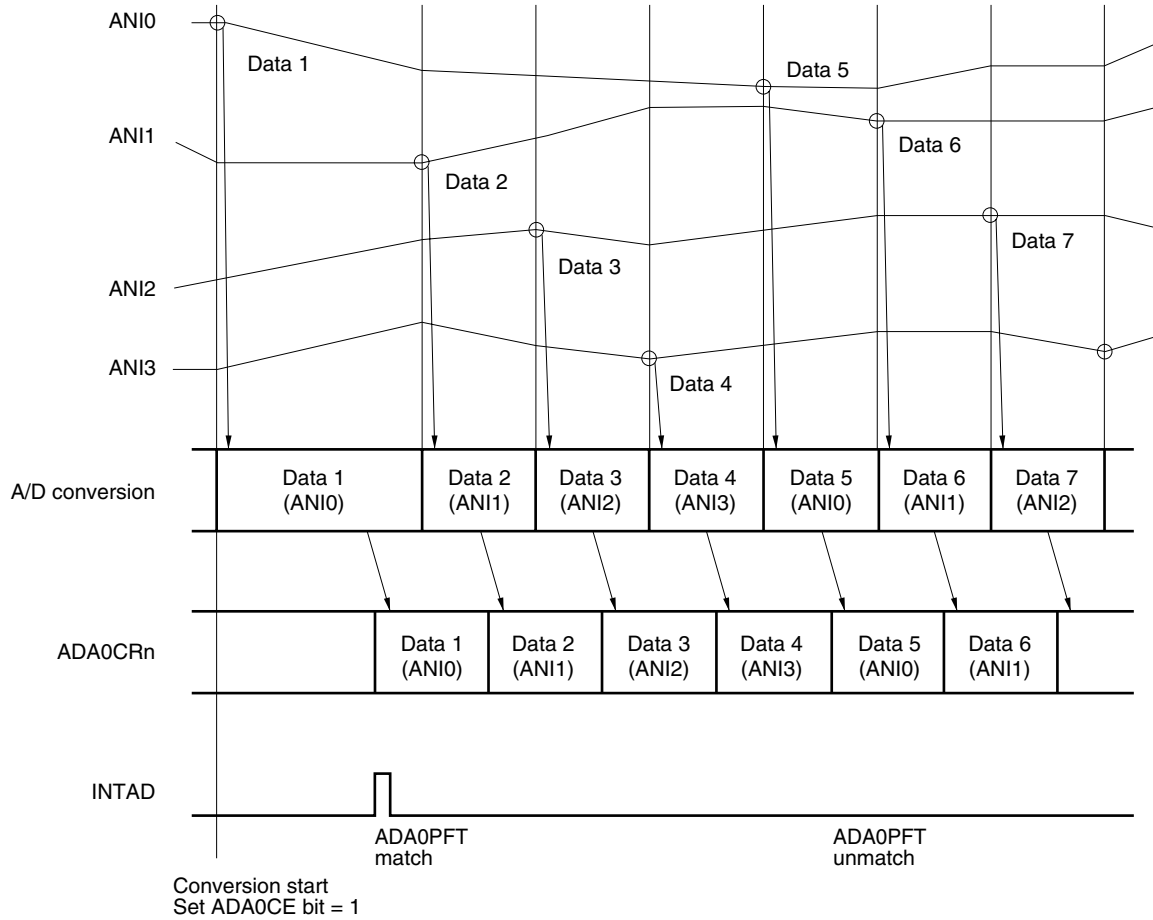

**(b) Block diagram**

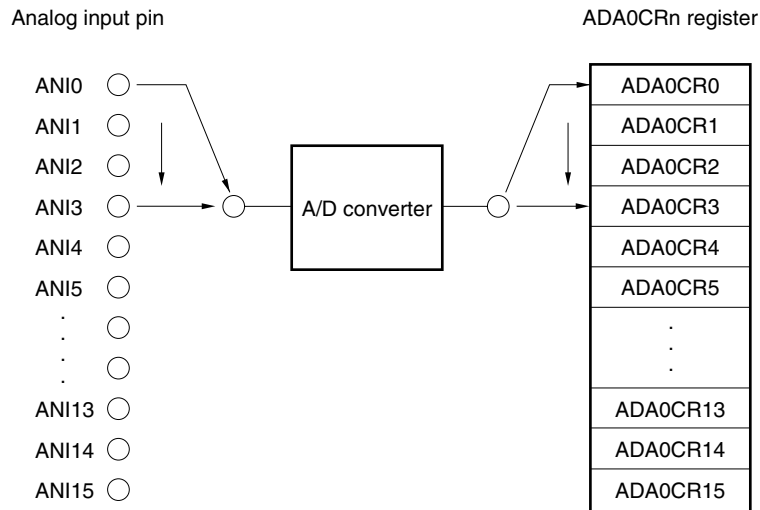

**(3) One-shot select mode**

In this mode, the result of converting the voltage of the analog input pin specified by the ADA0S register is compared with the set value of the ADA0PFT register. If the result of power-fail compare matches the condition set by the ADA0PFC bit, the conversion result is stored in the ADA0CRn register, and the INTAD signal is generated. If it does not match, the conversion result is stored in the ADA0CRn register, and the INTAD signal is not generated. Conversion is stopped after it has been completed.

**Figure 13-10. Timing Example of One-Shot Select Mode Operation  
(When Power-Fail Comparison Is Made: ADA0S Register = 01H)**

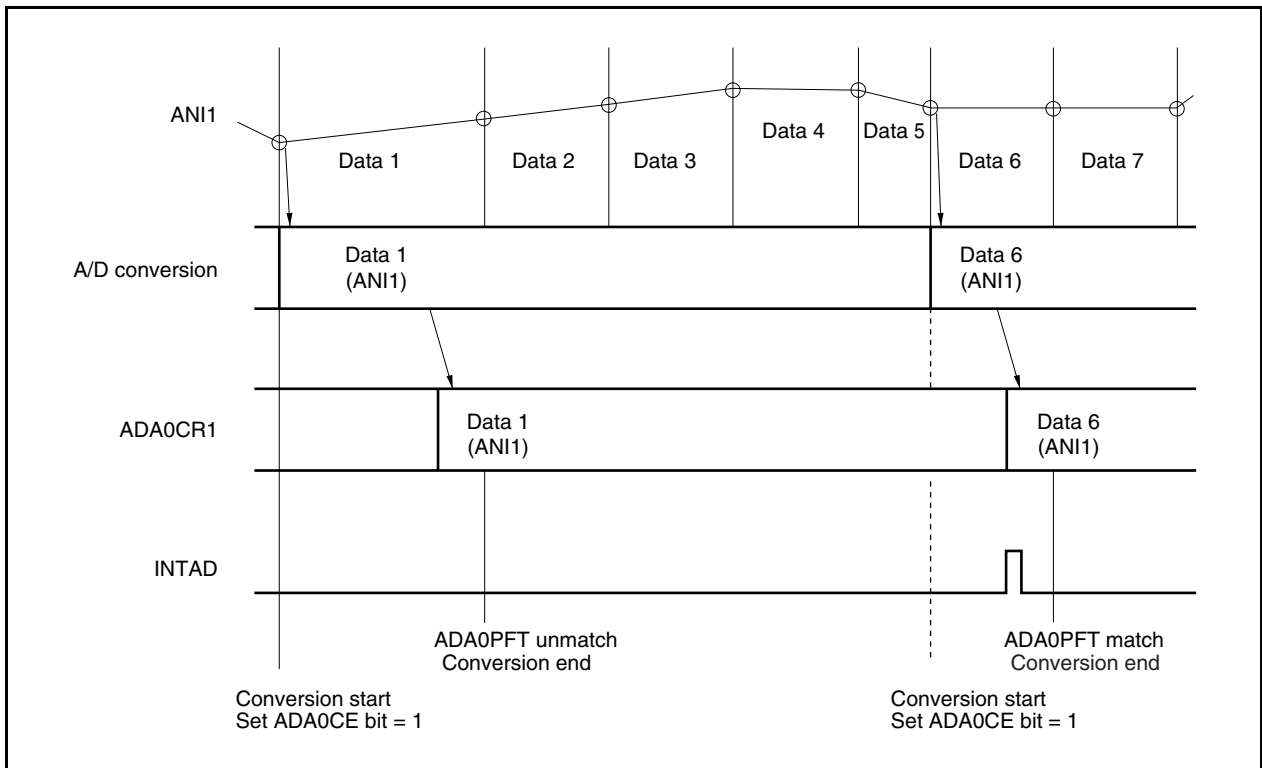
**(4) One-shot scan mode**

In this mode, the results of converting the voltages of the analog input pins sequentially selected from the ANI0 pin to the pin specified by the ADA0S register are stored, and the set value of the ADA0CR0H register of channel 0 is compared with the set value of the ADA0PFT register. If the result of power-fail compare matches the condition set by the ADA0PFC bit, the conversion result is stored in the ADA0CR0 register and the INTAD signal is generated. If it does not match, the conversion result is stored in the ADA0CR0 register, and the INTAD0 signal is not generated. After the result of the first conversion has been stored in the ADA0CR0 register, the results of converting the signals on the analog input pins specified by the ADA0S register are sequentially stored. The conversion is stopped after it has been completed.

**Figure 13-11. Timing Example of One-Shot Scan Mode Operation  
(When Power-Fail Comparison Is Made: ADA0S Register = 03H)**

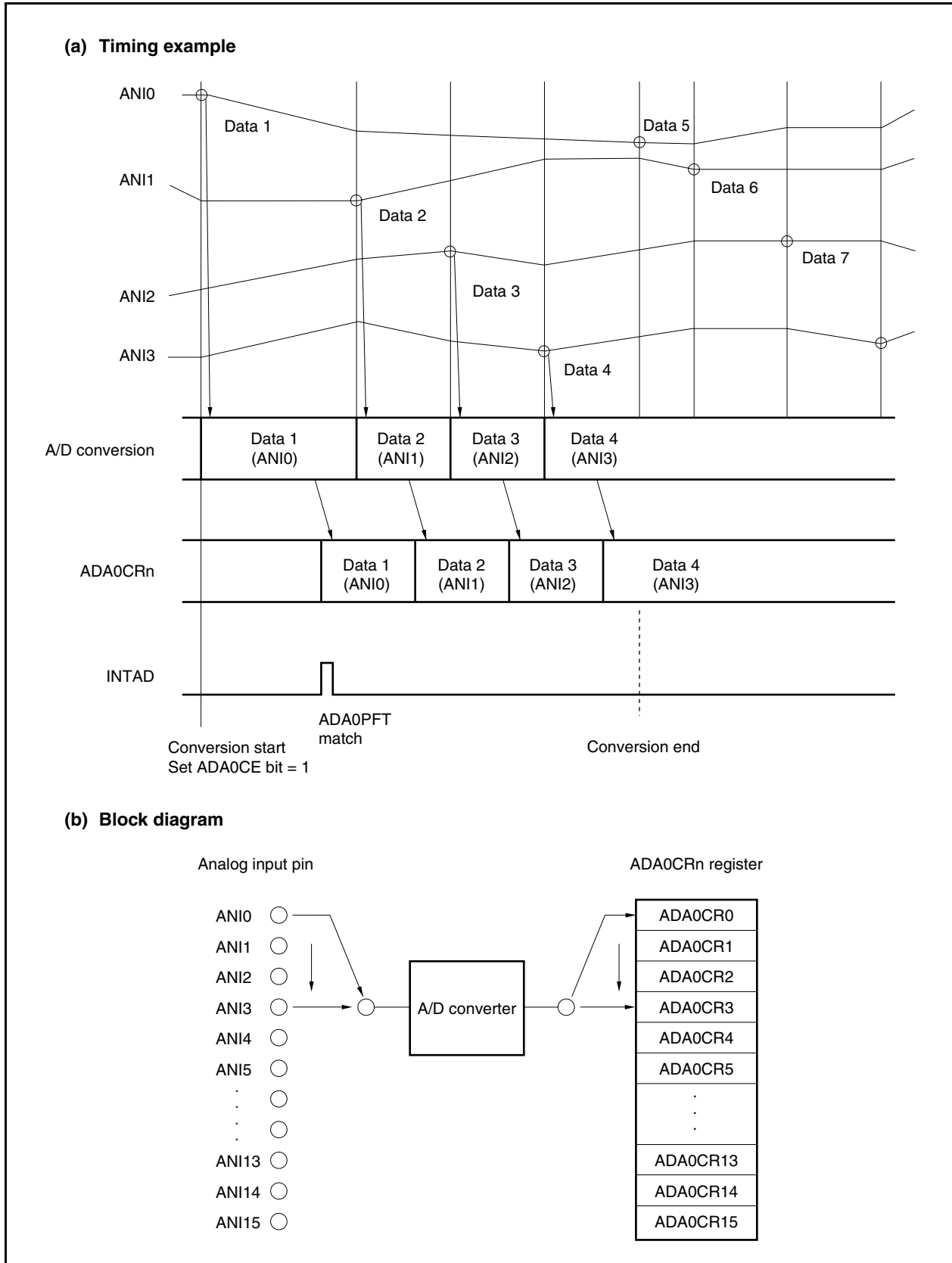



### 13.6 Cautions

**(1) When A/D converter is not used**

When the A/D converter is not used, the power consumption can be reduced by clearing the ADA0M0.ADA0CE bit to 0.

**(2) Input range of ANI0 to ANI15 pins**

Input the voltage within the specified range to the ANI0 to ANI15 pins. If a voltage equal to or higher than  $AV_{REF0}$  or equal to or lower than  $AV_{SS}$  (even within the range of the absolute maximum ratings) is input to any of these pins, the conversion value of that channel is undefined, and the conversion value of the other channels may also be affected.

**(3) Countermeasures against noise**

To maintain the 10-bit resolution, the ANI0 to ANI15 pins must be effectively protected from noise. The influence of noise increases as the output impedance of the analog input source becomes higher. To lower the noise, connecting an external capacitor as shown in Figure 13-12 is recommended.

**Figure 13-12. Processing of Analog Input Pin**

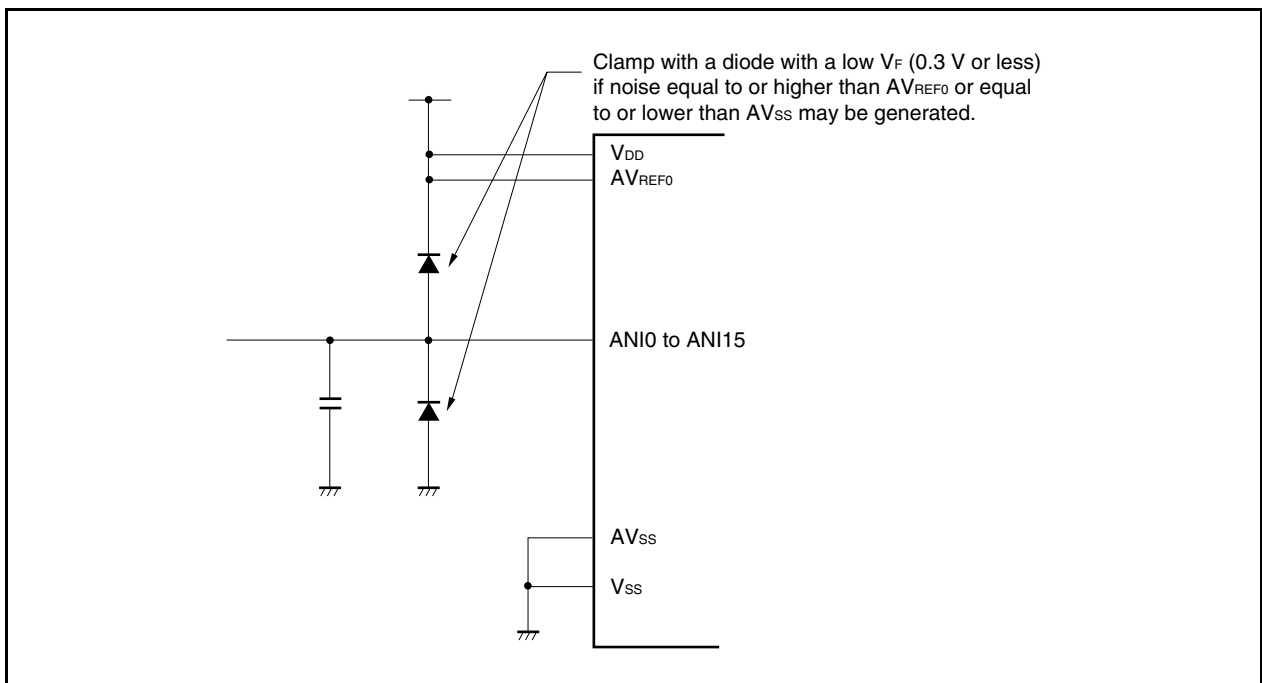

**(4) Alternate I/O**

The analog input (ANI0 to ANI15) pins are multiplexed with port pins. The  $AV_{REF0}$  power pin is multiplexed with the reference power supply to the A/D converter and the I/O buffer power supply of port 7. If any of the following processings is performed during A/D conversion, therefore, the expected A/D conversion value may not be obtained.

- (a) If a digital pulse is applied to a pin adjacent to a pin whose input analog signal is converted into a digital signal (for example, P72 and P74 pins during ANI3 conversion) (cause: influence of coupling noise)
- (b) If  $AV_{REF0}$  power supply fluctuates as a result of executing an instruction to read the P7H or P7L register to the input port during A/D conversion or an instruction to write data to the output port (cause: influence on the  $AV_{REF0}$  power supply)
- (c) If a current flows through a pin of port 7 (P70 to P715) that is set in the output mode because of the influence of the external circuit connected to the port pin and, as a result, the  $AV_{REF0}$  power supply fluctuates (cause: influence on the  $AV_{REF0}$  power supply)

If there is a possibility that any of the above processings may be executed during A/D conversion, be sure to execute A/D conversion more than once, check the A/D conversion value, and eliminate any abnormal value by program.

**(5) Interrupt request flag (ADIF)**

The interrupt request flag (ADIF) is not cleared even if the contents of the ADA0S register are changed. If the analog input pin is changed during A/D conversion, therefore, the result of converting the previously selected analog input signal may be stored and the conversion end interrupt request flag may be set immediately before the ADA0S register is rewritten. If the ADIF flag is read immediately after the ADA0S register is rewritten, the ADIF flag may be set even though the A/D conversion of the newly selected analog input pin has not been completed. When A/D conversion is stopped, clear the ADIF flag before resuming conversion.

**Figure 13-13. Generation Timing of A/D Conversion End Interrupt Request**

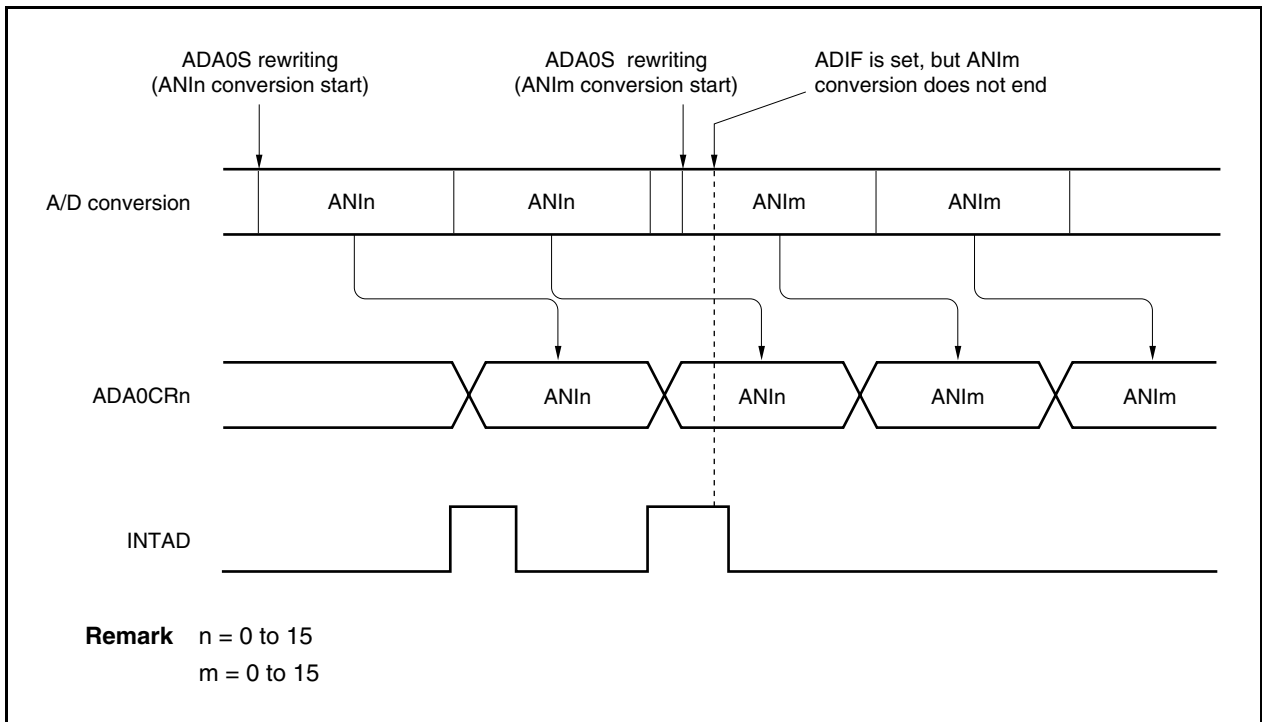

**(6) Internal equivalent circuit**

The following shows the equivalent circuit of the analog input block.

**Figure 13-14. Internal Equivalent Circuit of ANIn Pin**

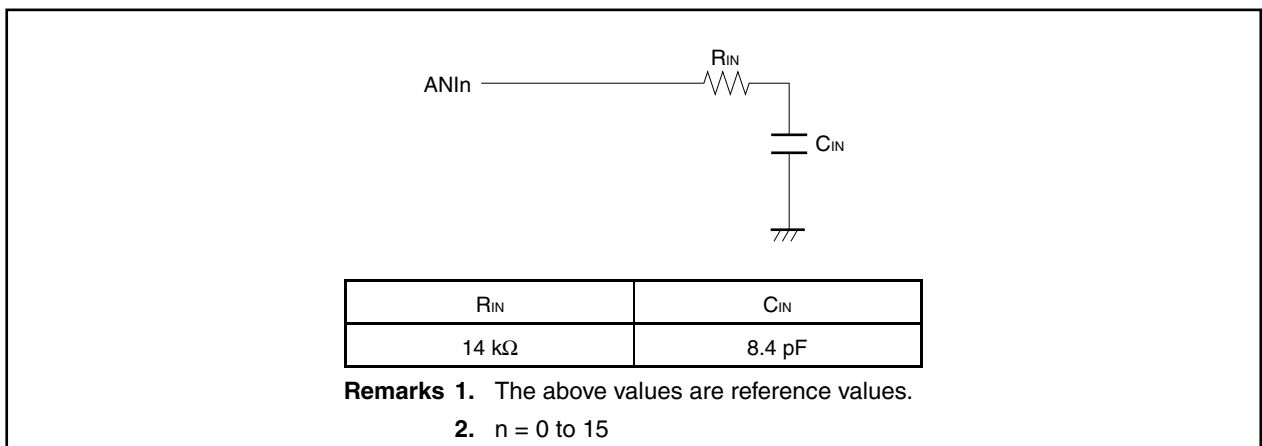

**(7) AV<sub>REF0</sub> pin**

- (a) The AV<sub>REF0</sub> pin is used as the power supply pin of the A/D converter and also supplies power to the alternate-function ports. In an application where a backup power supply is used, be sure to supply the same voltage as V<sub>DD</sub> to the AV<sub>REF0</sub> pin as shown in Figure 13-15.
- (b) The AV<sub>REF0</sub> pin is also used as the reference voltage pin of the A/D converter. If the source supplying power to the AV<sub>REF0</sub> pin has a high impedance or if the power supply has a low current supply capability, the reference voltage may fluctuate due to the current that flows during conversion (especially, immediately after the conversion operation enable bit ADA0CE has been set to 1). As a result, the conversion accuracy may drop. To avoid this, it is recommended to connect a capacitor across the AV<sub>REF0</sub> and AV<sub>SS</sub> pins to suppress the reference voltage fluctuation as shown in Figure 13-15.
- (c) If the source supplying power to the AV<sub>REF0</sub> pin has a high DC resistance (for example, because of insertion of a diode), the voltage when conversion is enabled may be lower than the voltage when conversion is stopped, because of a voltage drop caused by the A/D conversion current.

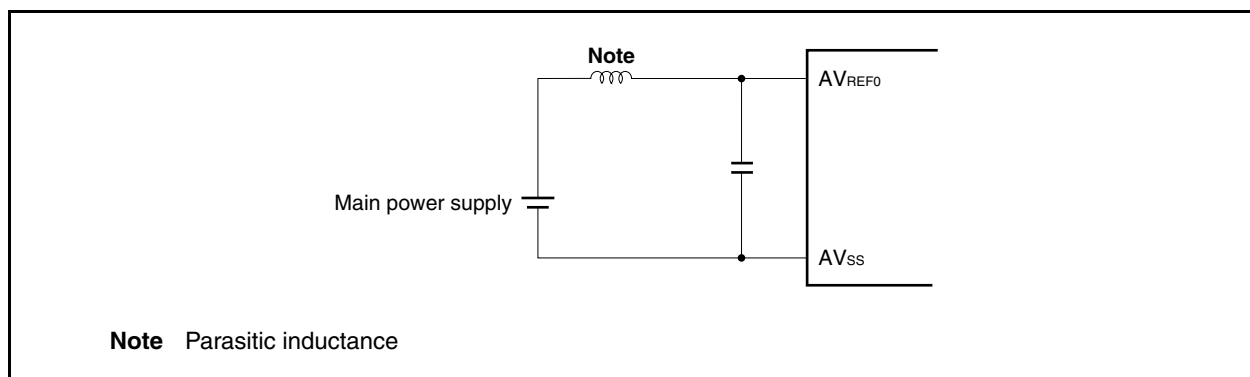
**Figure 13-15. AV<sub>REF0</sub> Pin Processing Example****(8) Reading ADA0CRn register**

When the ADA0M0 to ADA0M2, ADA0S, ADA0PFM, or ADA0PFT register is written, the contents of the ADA0CRn register may be undefined. Read the conversion result after completion of conversion and before writing to the ADA0M0 to ADA0M2, ADA0S, ADA0PFM, or ADA0PFT register. Also, when an external/timer trigger is acknowledged, the contents of the ADA0CRn register may be undefined. Read the conversion result after completion of conversion and before the next external/timer trigger is acknowledged. The correct conversion result may not be read at a timing different from the above.

**(9) Standby mode**

Because the A/D converter stops operating in the STOP mode, conversion results are invalid, so power consumption can be reduced. Operations are resumed after the STOP mode is released, but the A/D conversion results after the STOP mode is released are invalid. When using the A/D converter after the STOP mode is released, before setting the STOP mode or releasing the STOP mode, clear the ADA0M0.ADA0CE bit to 0 then set the ADA0CE bit to 1 after releasing the STOP mode.

In the IDLE1, IDLE2, or subclock operation mode, operation continues. To lower the power consumption, therefore, clear the ADA0M0.ADA0CE bit to 0. In the IDLE1 and IDLE2 modes, since the analog input voltage value cannot be retained, the A/D conversion results after the IDLE1 and IDLE2 modes are released are invalid. The results of conversions before the IDLE1 and IDLE2 modes were set are valid.

**(10) Restriction for each mode**

- (a) To select the external trigger mode/timer trigger mode, set the high-speed conversion mode. Do not input a trigger during stabilization time that is inserted once after the A/D conversion operation is enabled (ADA0M0.ADA0CE bit = 1).
  
- (b) In the following modes, write data to the A/D control register while A/D conversion is stopped (ADA0CE bit = 0), and then enable the A/D conversion operation (ADA0CE bit = 1).
  - Normal conversion mode
  - One-shot select mode/one-shot scan mode of high-speed conversion mode

**Remark** A/D control registers: ADA0M0, ADA0M2, ADA0S, ADA0PFM, and ADA0PFT registers

**(11) Variation of A/D conversion results**

The results of the A/D conversion may vary depending on the fluctuation of the supply voltage, or may be affected by noise. To reduce the variation, take counteractive measures with the program such as averaging the A/D conversion results.

**(12) A/D conversion result hysteresis characteristics**

The successive comparison type A/D converter holds the analog input voltage in the internal sample & hold capacitor and then performs A/D conversion. After the A/D conversion has finished, the analog input voltage remains in the internal sample & hold capacitor. As a result, the following phenomena may occur.

- When the same channel is used for A/D conversions, if the voltage is higher or lower than the previous A/D conversion, then hysteresis characteristics may appear where the conversion result is affected by the previous value. Thus, even if the conversion is performed at the same potential, the result may vary.
- When switching the analog input channel, hysteresis characteristics may appear where the conversion result is affected by the previous channel value. This is because one A/D converter is used for the A/D conversions. Thus, even if the conversion is performed at the same potential, the result may vary.

## 13.7 How to Read A/D Converter Characteristics Table

This section describes the terms related to the A/D converter.

### (1) Resolution

The minimum analog input voltage that can be recognized, i.e., the ratio of an analog input voltage to 1 bit of digital output is called 1 LSB (least significant bit). The ratio of 1 LSB to the full scale is expressed as %FSR (full-scale range). %FSR is the ratio of a range of convertible analog input voltages expressed as a percentage, and can be expressed as follows, independently of the resolution.

$$\begin{aligned} 1\%FSR &= (\text{Maximum value of convertible analog input voltage} - \text{Minimum value of convertible analog input voltage})/100 \\ &= (AV_{REF0} - 0)/100 \\ &= AV_{REF0}/100 \end{aligned}$$

When the resolution is 10 bits, 1 LSB is as follows:

$$\begin{aligned} 1 \text{ LSB} &= 1/2^{10} = 1/1,024 \\ &= 0.098\%FSR \end{aligned}$$

The accuracy is determined by the overall error, independently of the resolution.

### (2) Overall error

This is the maximum value of the difference between an actually measured value and a theoretical value. It is a total of zero-scale error, full-scale error, linearity error, and a combination of these errors. The overall error in the characteristics table does not include the quantization error.

Figure 13-16. Overall Error

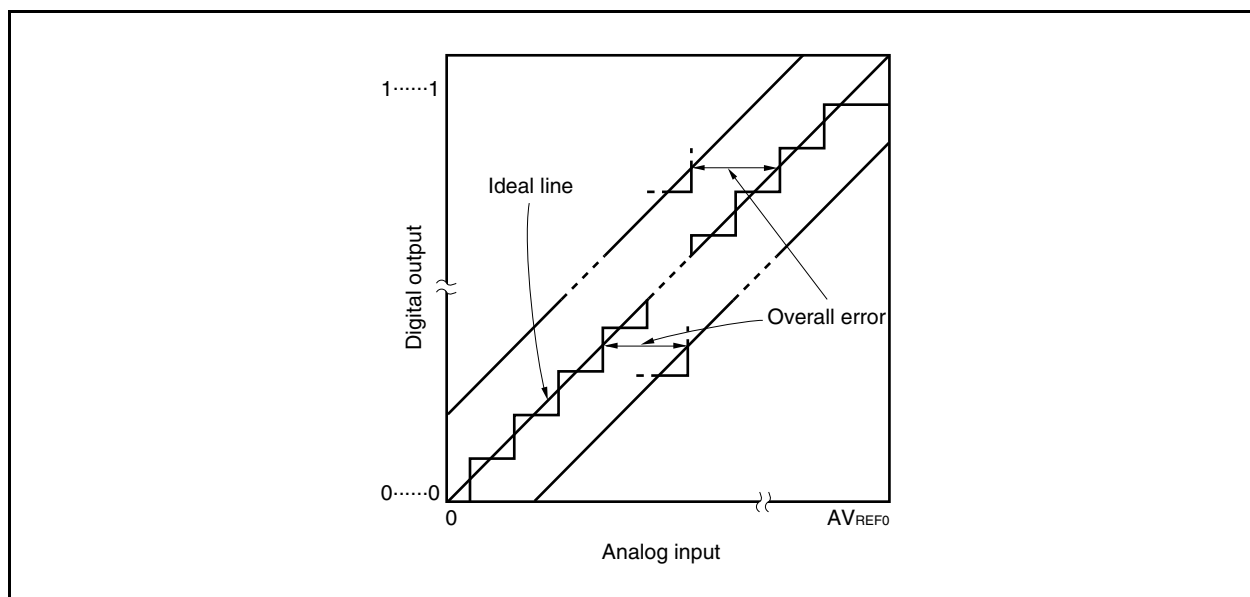

**(3) Quantization error**

This is an error of  $\pm 1/2$  LSB that inevitably occurs when an analog value is converted into a digital value. Because the A/D converter converts analog input voltages in a range of  $\pm 1/2$  LSB into the same digital codes, a quantization error is unavoidable.

This error is not included in the overall error, zero-scale error, full-scale error, integral linearity error, or differential linearity error in the characteristics table.

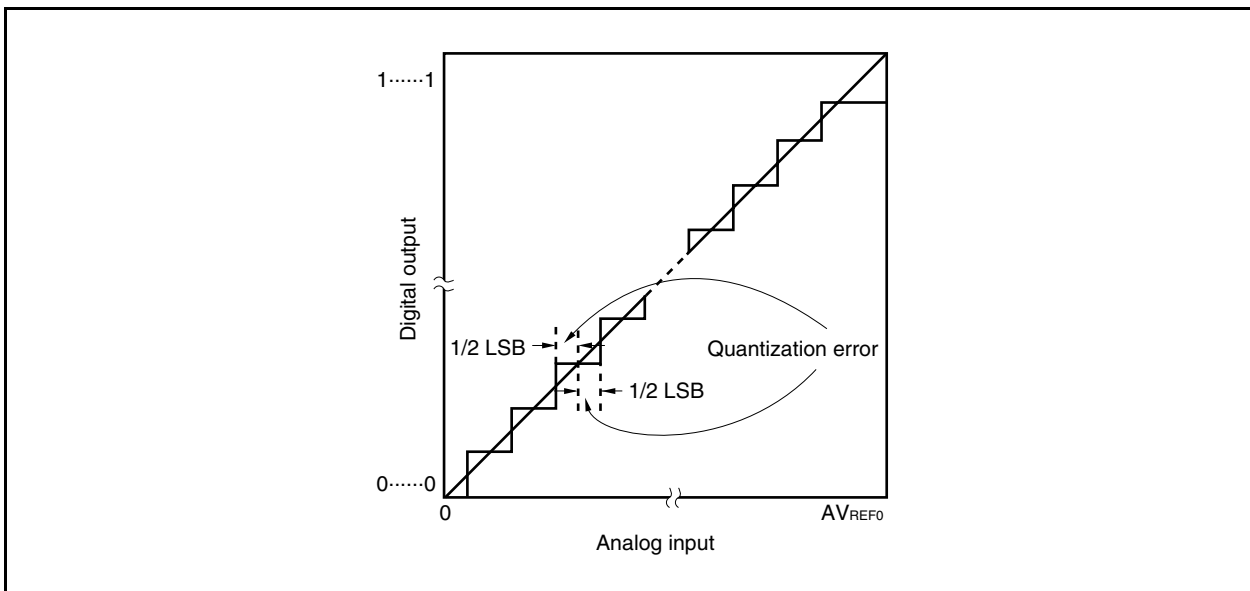
**Figure 13-17. Quantization Error****(4) Zero-scale error**

This is the difference between the actually measured analog input voltage and its theoretical value when the digital output changes from 0...000 to 0...001 ( $1/2$  LSB).

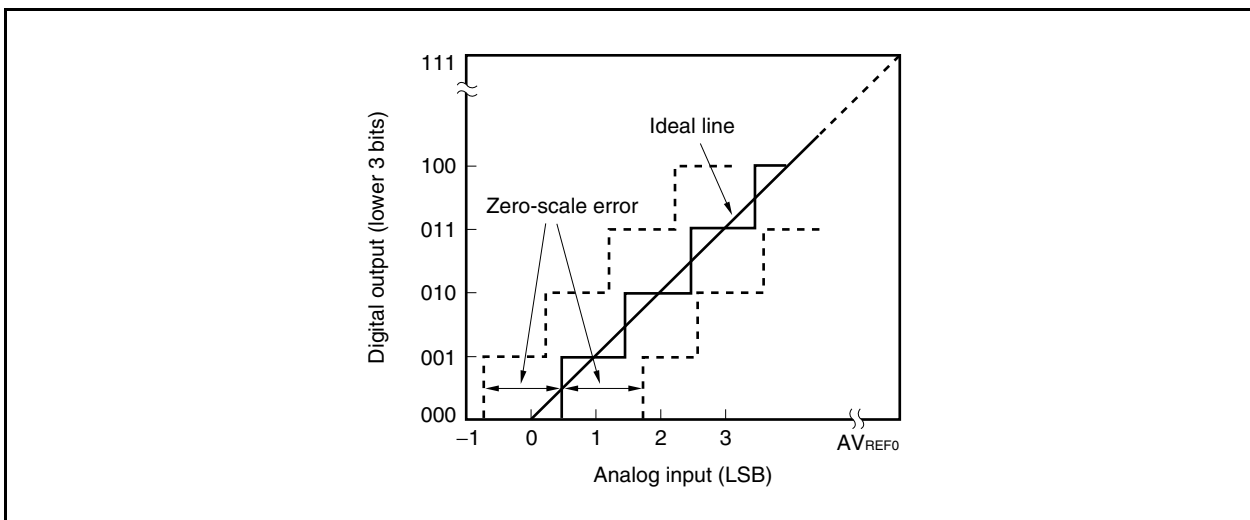
**Figure 13-18. Zero-Scale Error**

**(5) Full-scale error**

This is the difference between the actually measured analog input voltage and its theoretical value when the digital output changes from 1...110 to 1...111 (full scale – 3/2 LSB).

**Figure 13-19. Full-Scale Error**

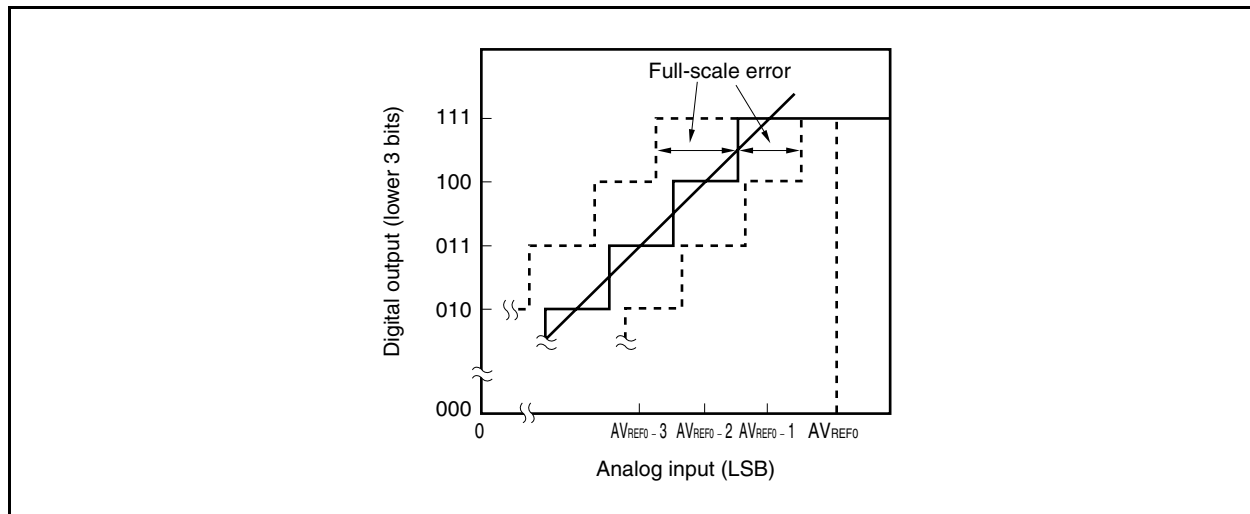

**(6) Differential linearity error**

Ideally, the width to output a specific code is 1 LSB. This error indicates the difference between the actually measured value and its theoretical value when a specific code is output. This indicates the basic characteristics of the A/D conversion when the voltage applied to the analog input pins of the same channel is consistently increased bit by bit from  $AV_{SS}$  to  $AV_{REF0}$ . When the input voltage is increased or decreased, or when two or more channels are used, refer to **13.7 (2) Overall error**.

**Figure 13-20. Differential Linearity Error**

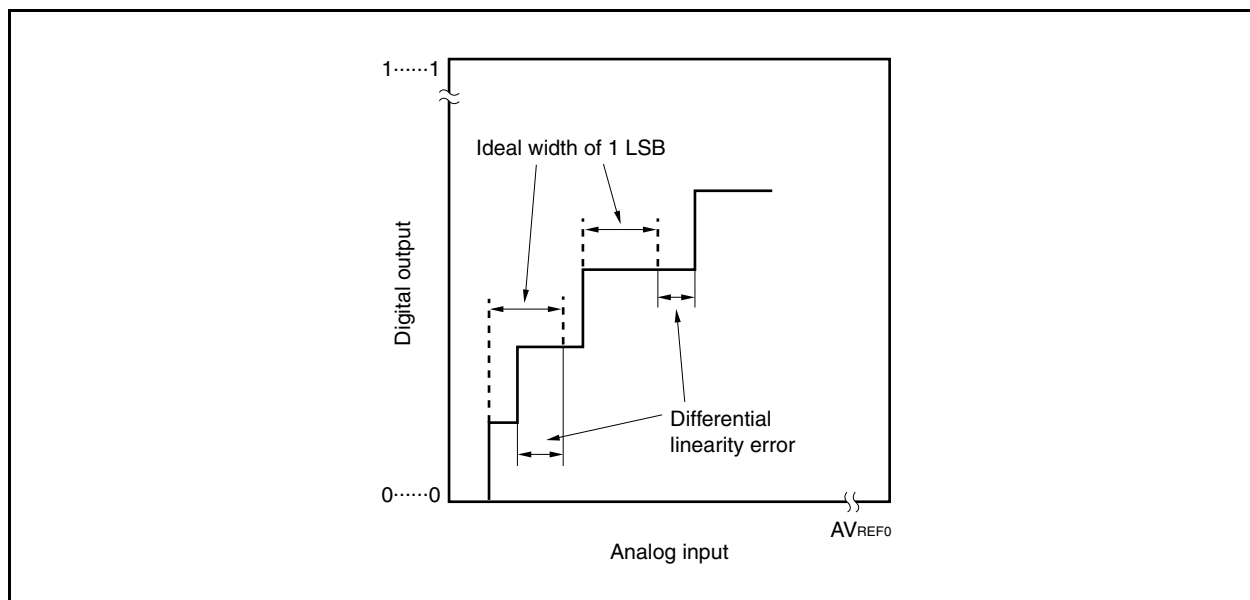



**(7) Integral linearity error**

This error indicates the extent to which the conversion characteristics differ from the ideal linear relationship. It indicates the maximum value of the difference between the actually measured value and its theoretical value where the zero-scale error and full-scale error are 0.

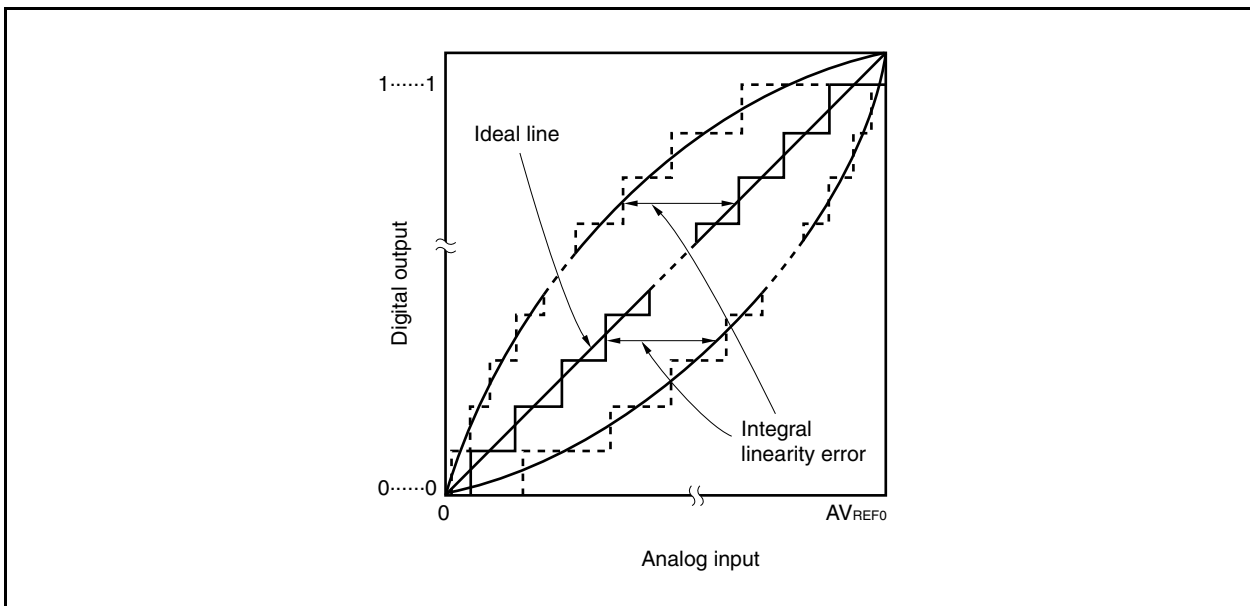
**Figure 13-21. Integral Linearity Error****(8) Conversion time**

This is the time required to obtain a digital output after each trigger has been generated. The conversion time in the characteristics table includes the sampling time.

**(9) Sampling time**

This is the time for which the analog switch is ON to load an analog voltage to the sample & hold circuit.

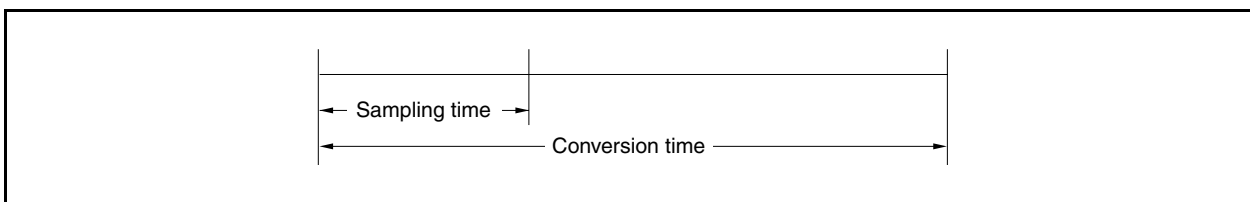
**Figure 13-22. Sampling Time**

## CHAPTER 14 D/A CONVERTER

### 14.1 Functions

The D/A converter has the following functions.

- 8-bit resolution  $\times$  2 channels (DA0CS0, DA0CS1)
- R-2R ladder method
- Settling time: 3  $\mu$ s max. (when  $AV_{REF1}$  is 3.0 to 3.6 V and external load is 20 pF)
- Analog output voltage:  $AV_{REF1} \times m/256$  ( $m = 0$  to 255; value set to DA0CSn register)
- Operation modes: Normal mode, real-time output mode

**Remark**  $n = 0, 1$

### 14.2 Configuration

The D/A converter configuration is shown below.

**Figure 14-1. Block Diagram of D/A Converter**

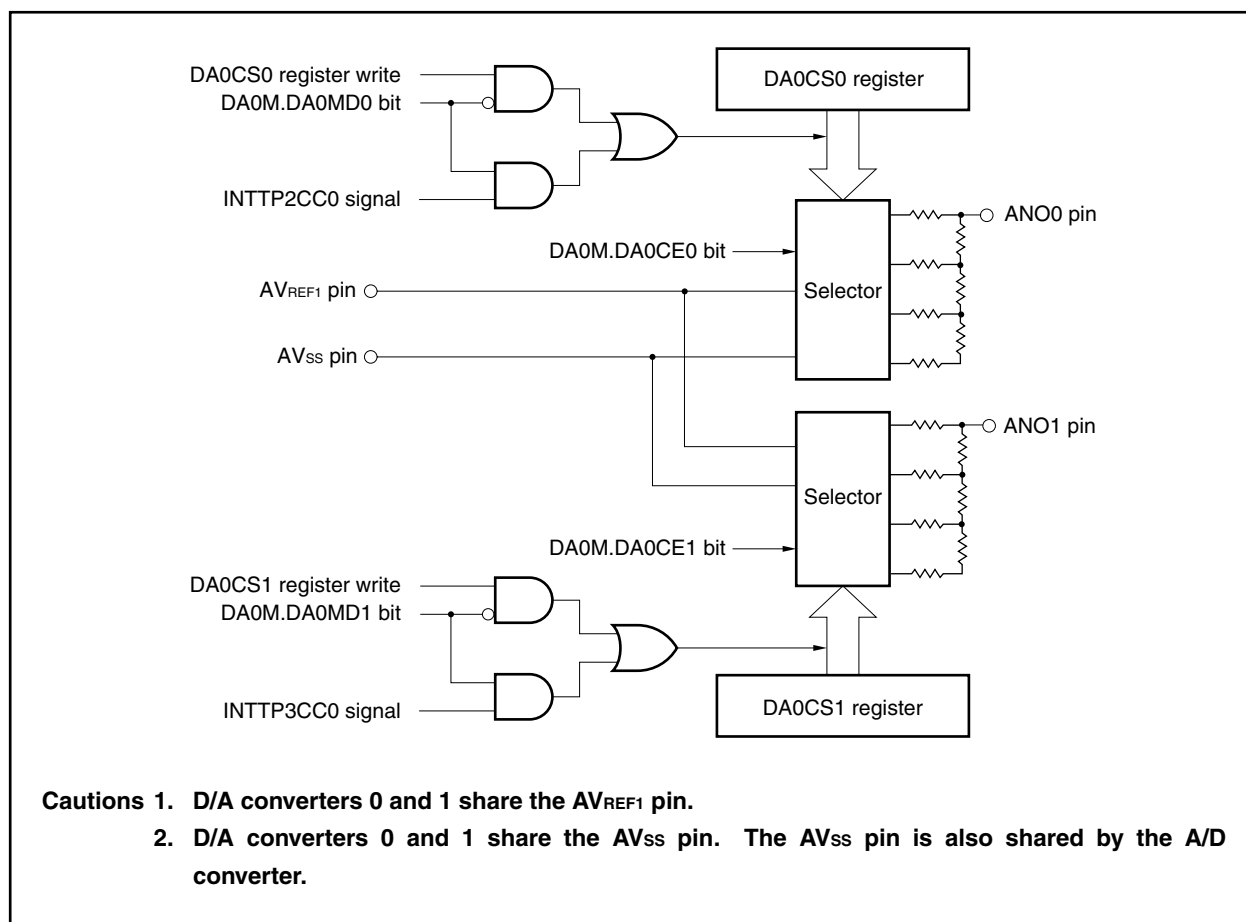

The D/A converter consists of the following hardware.

**Table 14-1. Configuration of D/A Converter**

Item	Configuration
Control registers	D/A converter mode register (DA0M) D/A converter conversion value setting registers 0, 1 (DA0CS0, DA0CS1)

### 14.3 Registers

The registers that control the D/A converter are as follows.

- D/A converter mode register (DA0M)
- D/A converter conversion value setting registers 0, 1 (DA0CS0, DA0CS1)

#### (1) D/A converter mode register (DA0M)

The DA0M register controls the operation of the D/A converter.

This register can be read or written in 8-bit or 1-bit units.

Reset sets this register to 00H.

After reset: 00H								R/W	Address: FFFF282H								
	7	6	<5>	<4>	3	2	1	0									
DA0M	0	0	DA0CE1	DA0CE0	0	0	DA0MD1	DA0MD0									

DA0CE <sub>n</sub>	Control of D/A converter operation enable/disable (n = 0, 1)
0	Disables operation
1	Enables operation

DA0MD <sub>n</sub>	Selection of D/A converter operation mode (n = 0, 1)
0	Normal mode
1	Real-time output mode <sup>Note</sup>

**Note** The output trigger in the real-time output mode (DA0MD<sub>n</sub> bit = 1) is as follows.

- When n = 0: INTTP2CC0 signal (see **CHAPTER 7 16-BIT TIMER/EVENT COUNTER P (TMP)**)
- When n = 1: INTTP3CC0 signal (see **CHAPTER 7 16-BIT TIMER/EVENT COUNTER P (TMP)**)

**Caution** Be sure to set bits 2, 3, 6, and 7 to “0”.

**(2) D/A converter conversion value setting registers 0, 1 (DA0CS0, DA0CS1)**

The DA0CS0 and DA0CS1 registers set the analog voltage value output to the ANO0 and ANO1 pins.

These registers can be read or written in 8-bit units.

Reset sets these registers to 00H.

After reset: 00H    R/W    Address: DA0CS0 FFFFF280H, DA0CS1 FFFFF281H

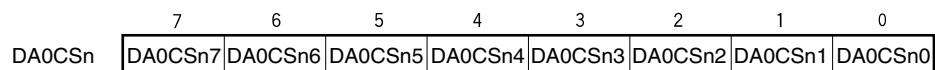

**Caution** In the real-time output mode (DA0M.DA0MDn bit = 1), set the DA0CSn register before the INTTP2CC0/INTTP3CC0 signals are generated. D/A conversion starts when the INTTP2CC0/INTTP3CC0 signals are generated.

**Remark** n = 0, 1

## 14.4 Operation

### 14.4.1 Operation in normal mode

D/A conversion is performed using a write operation to the DA0CSn register as the trigger.

The setting method is described below.

- <1> Set the DA0M.DA0MDn bit to 0 (normal mode).
- <2> Set the analog voltage value to be output to the ANOn pin to the DA0CSn register.  
Steps <1> and <2> above constitute the initial settings.
- <3> Set the DA0M.DA0CEn bit to 1 (D/A conversion enable).  
D/A conversion starts when this setting is performed.
- <4> To perform subsequent D/A conversions, write to the DA0CSn register.  
The previous D/A conversion result is held until the next D/A conversion is performed.

- Remarks**
1. For the alternate-function pin settings, see **Table 4-25 Using Port Pin as Alternate-Function Pin**.
  2. n = 0, 1

### 14.4.2 Operation in real-time output mode

D/A conversion is performed using the interrupt request signals (INTTP2CC0 and INTTP3CC0) of TMP2 and TMP3 as triggers.

The setting method is described below.

- <1> Set the DA0M.DA0MDn bit to 1 (real-time output mode).
- <2> Set the analog voltage value to be output to the ANOn pin to the DA0CSn register.
- <3> Set the DA0M.DA0CEn bit to 1 (D/A conversion enable).  
Steps <1> to <3> above constitute the initial settings.
- <4> Operate TMP2 and TMP3.
- <5> D/A conversion starts when the INTTP2CC0 and INTTP3CC0 signals are generated.
- <6> After that, the value set in DA0CSn register is output every time the INTTP2CC0 and INTTP3CC0 signals are generated.

- Remarks**
1. The output values of the ANO0 and ANO1 pins up to <5> above are undefined.
  2. For the output values of the ANO0 and ANO1 pins in the HALT, IDLE1, IDLE2, and STOP modes, see **CHAPTER 26 STANDBY FUNCTION**.
  3. For the alternate-function pin settings, see **Table 4-25 Using Port Pin as Alternate-Function Pin**.

### 14.4.3 Cautions

Observe the following cautions when using the D/A converter of the V850E/SJ3-H or V850E/SK3-H.

- (1) Do not change the set value of the DA0CSn register while the trigger signal is being issued in the real-time output mode.
- (2) Before changing the operation mode, be sure to clear the DA0M.DA0CEn bit to 0.
- (3) When using one of the P10/AN00 and P11/AN01 pins as an I/O port and the other as a D/A output pin, do so in an application where the port I/O level does not change during D/A output.
- (4) Make sure that  $AV_{REF0} = V_{DD} = AV_{REF1} = 3.0$  to  $3.6$  V. If this range is exceeded, the operation is not guaranteed.
- (5) Apply and cut power to  $AV_{REF1}$  at the same timing as  $AV_{REF0}$ .
- (6) No current can be output from the ANOn pin ( $n = 0, 1$ ) because the output impedance of the D/A converter is high. When connecting a resistor of  $2$  M $\Omega$  or less, insert a JFET input operational amplifier between the resistor and the ANOn pin.

**Figure 14-2. External Pin Connection Example**

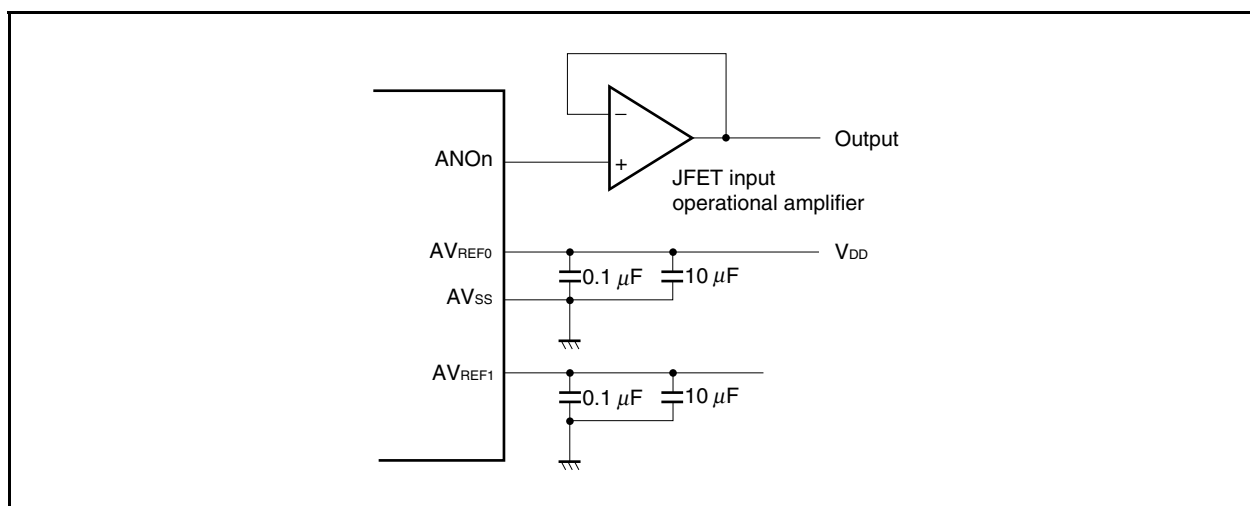

- (7) Because the D/A converter stops operation in the STOP mode, the ANO0 and ANO1 pins go into a high-impedance state, and the power consumption can be reduced. In the IDLE1, IDLE2, or subclock operation mode, however, the operation continues. To lower the power consumption, therefore, clear the DA0M.DA0CEn bit to 0.

## CHAPTER 15 ASYNCHRONOUS SERIAL INTERFACE A (UARTA)

### 15.1 Port Settings of UARTA0 to UARTA5

#### 15.1.1 For V850E/SJ3-H

**Table 15-1. Pin Configuration**

Mode	Pin Name	Alternate-Function Pin					
		Port <1>			Port <2>		
		Pin No.	Port	Alternate Function	Pin No.	Port	Alternate Function
UARTA0	TXDA0	25	P30	SOB4	–	–	–
	RXDA0	26	P31	INTP7/SIB4	–	–	–
UARTA1	TXDA1	61	P90	A0/KR6/SDA02	–	–	–
	RXDA1	62	P91	A1/KR7/KR7/SCL02	–	–	–
UARTA2	TXDA2	35	P38	SDA00/SIB2	–	–	–
	RXDA2	36	P39	SCL00/ $\overline{\text{SCKB2}}$	–	–	–
UARTA3	TXDA3	60	P81	RC1CKO/RC1CKDIV	–	–	–
	RXDA3	59	P80	INTP8/RC1CK1HZ	–	–	–
UARTA4	TXDA4	44	P61	RTP11/SOE0 <sup>Note</sup>	–	–	–
	RXDA4	43	P60	RTP10/SIE0 <sup>Note</sup>	–	–	–
UARTA5	TXDA5	51	P68	$\overline{\text{SCKB5}}$ /SCL05 <sup>Note</sup>	–	–	–
	RXDA5	50	P67	SOB5/SDA05 <sup>Note</sup>	–	–	–

<R>

<R>

<R>

<R>

<R>

**Note** Not available in the  $\mu$ PD70F3931, 70F3932, and 70F3933.

#### (1) UARTA0

The transmission/reception pins (TXDA0 and RXDA0) of UARTA0 are assigned to P30 and P31, respectively. When using UARTA0, specify P30 and P31 as the TXDA0 and RXDA0/INTP7 pins in advance, using the PMC3 and PFC3 registers. Furthermore, disable the edge detection of the INTP7 pin at P31 (INTF3.INTF31 bit = 0, INTR3.INTR31 bit = 0).

The TXDA0 and RXDA0 pins and the transmission/reception pins (SOB4 and SIB4) of CSIB4 are alternate functions of the same pin, and therefore cannot be used simultaneously. In addition, the RXDA0 pin also functions alternately as the INTP7 pin (external interrupt input), so use the INTP7 pin assigned to another port pin (P51) when using the RXDA0 and INTP7 pins simultaneously.

#### (2) UARTA1

The transmission/reception pins (TXDA1 and RXDA1) of UARTA1 are assigned to P90 and P91, respectively. When using UARTA1, specify P90 and P91 as the TXDA1 and RXDA1/KR7 pins in advance, using the PMC9, PFC9, and PFCE9 registers. Furthermore, disable the edge detection of the KR7 pin at P91 (KRM.KRM7 bit = 0).

The TXDA1 and RXDA1 pins, the serial transmission/reception data/serial clock pins (SDA02 and SCL02) of I<sup>2</sup>C02, the address bus pins (A0 and A1), and the key interrupt input pins (KR6 and KR7) are alternate functions of the same pin, and therefore cannot be used simultaneously.

**(3) UARTA2**

The transmission/reception pins (TXDA2 and RXDA2) of UARTA2 are assigned to P38 and P39, respectively. When using UARTA2, specify P38 and P39 as the TXDA2 and RXDA2 pins in advance, using the PMC3, PFC3, and PFCE3 registers.

The TXDA2 and RXDA2 pins and the serial clock/serial transmission/reception data pins (SDA00 and SCL00) of I<sup>2</sup>C00 are alternate functions of the same pin, and therefore cannot be used simultaneously. In addition, the TXDA2 and RXDA2 pins also function alternately as the serial reception data/serial clock pin (SIB2 and  $\overline{\text{SCKB2}}$ ) of CSIB2, so use the SIB2 and  $\overline{\text{SCKB2}}$  pins assigned to other port pins (P53 and P55) when using the TXDA2 and RXDA2 pins and the SIB2 and  $\overline{\text{SCKB2}}$  pins simultaneously.

**(4) UARTA3**

The transmission/reception pins (TXDA3 and RXDA3) of UARTA3 are assigned to P81 and P80, respectively. When using UARTA3, specify P81 and P80 as the TXDA3 and RXDA3/INTP8 pins in advance, using the PMC8, PFC8, and PFCE8 registers. Furthermore, disable the edge detection of the INTP8 pin at P80 (INTF8.INTF80 bit = 0, INTR3.INTR80 bit = 0).

The TXDA3 and RXDA3 pins and the clock output pins (RC1CKO, RC1CKDIV, and RC1CK1HZ) of RTC are alternate functions of the same pin, and therefore cannot be used simultaneously. In addition, the RXDA3 pin also functions alternately as the INTP8 pin (external interrupt input), so use the INTP8 pin assigned to another port pin (P93) when using the RXDA3 and INTP8 pins simultaneously.

**(5) UARTA4**

The transmission/reception pins (TXDA4 and RXDA4) of UARTA4 are assigned to P61 and P60, respectively. When using UARTA4, specify P61 and P60 as the TXDA4 and RXDA4 pins in advance, using the PMC6, PFC6, and PFCE6 registers.

<R> The TXDA4 and RXDA4 pins, the transmission/reception pins (SOE0 and SIE0)<sup>Note</sup>, and the real-time output pins (RTP11 and RTP10) are alternate functions of the same pin, and therefore cannot be used simultaneously.

**(6) UARTA5**

The transmission/reception pins (TXDA5 and RXDA5) of UARTA5 are assigned to P68 and P67, respectively. When using UARTA5, specify P68 and P67 as the TXDA5 and RXDA5 pins in advance, using the PMC6, PFC6, and PFCE6 registers.

<R> The TXDA5 and RXDA5 pins, the serial clock/serial transmission data pins ( $\overline{\text{SCKB5}}$  and SOB5) of CSIB5 and the serial clock/serial transmission/reception data pins (SCL05 and SDA05)<sup>Note</sup> of I<sup>2</sup>C05 are alternate functions of the same pin, and therefore cannot be used simultaneously.

<R> **Note** Not available in the  $\mu$ PD70F3931, 70F3932, and 70F3933.

**Caution** Do not switch port settings during operation. Also, be sure to disable operation of unused units for which port settings are not made.



## 15.1.2 For V850E/SK3-H

Table 15-2. Pin Configuration

Mode	Pin Name	Alternate-Function Pin					
		Port <1>			Port <2>		
		Pin No.	Port	Alternate Function	Pin No.	Port	Alternate Function
UARTA0	TXDA0	30	P30	SOB4	–	–	–
	RXDA0	31	P31	INTP7/SIB4	–	–	–
UARTA1	TXDA1	77	P90	A0/KR6/SDA02	94	P151	
	RXDA1	78	P91	A1/KR7/KR7/SCL02	93	P150	KR7
UARTA2	TXDA2	40	P38	SDA00/SIB2	43	P311	–
	RXDA2	41	P39	SCL00/ $\overline{\text{SCKB2}}$	44	P312	–
UARTA3	TXDA3	72	P81	RC1CK0/RC1CKDIV	–	–	–
	RXDA3	71	P80	INTP8/RC1CK1HZ	–	–	–
UARTA4	TXDA4	54	P61	RTP11/SOE0	52	P57	–
	RXDA4	53	P60	RTP10/SIE0	51	P56	–
UARTA5	TXDA5	61	P68	$\overline{\text{SCKB5}}$ /SCL05	76	P85	–
	RXDA5	60	P67	SOB5/SDA05	75	P84	–

**(1) UARTA0**

The transmission/reception pins (TXDA0 and RXDA0) of UARTA0 are assigned to P30 and P31, respectively. When using UARTA0, specify P30 and P31 as the TXDA0 and RXDA0/INTP7 pins in advance, using the PMC3 and PFC3 registers. Furthermore, disable the edge detection of the INTP7 pin at P31 (INTF3.INTF31 bit = 0, INTR3.INTR31 bit = 0).

The TXDA0 and RXDA0 pins and the transmission/reception pins (SOB4 and SIB4) of CSIB4 are alternate functions of the same pin, and therefore cannot be used simultaneously. In addition, the RXDA0 pin also functions alternately as the INTP7 pin (external interrupt input), so use the INTP7 pin assigned to another port pin (P51) when using the RXDA0 and INTP7 pins simultaneously.

**(2) UARTA1**

The transmission/reception pins (TXDA1 and RXDA1) of UARTA1 are assigned to two port pins P90, P91 and P151, P150, respectively, and can be used at either one of the two port pins only. When using UARTA1 at P90 and P91, specify P90 and P91 as the TXDA1 and RXDA1/KR7 pins in advance, using the PMC9, PFC9, and PFCE9 registers. Furthermore, disable the edge detection of the KR7 pin at P91 (KRM.KRM7 bit = 0). When using UARTA1 at P151 and P150, specify P151 and P150 as the TXDA1 and RXDA1/KR7 pins in advance, using the PMC15 register. Furthermore, disable the edge detection of the KR7 pin at P150 (KRM.KRM7 bit = 0).

RXDA1 and KR7 (key interrupt input) are alternate functions of both P91 and P150, and therefore cannot be used simultaneously. P90 and P91 also function as the serial transmission/reception data/serial clock pins (SDA02 and SCL02), address bus pins (A0 and A1), and key interrupt input pin (KR6) of I<sup>2</sup>C02. By using UARTA1 at P150 and P151, these alternate functions can be used simultaneously with UARTA1.

**(3) UARTA2**

The transmission/reception pins (TXDA2 and RXDA2) of UARTA2 are assigned to two port pins P38, P39 and P311, P312, respectively, and can be used at either one of the two port pins only. When using UARTA2 at P38 and P39, specify P38 and P39 as the TXDA2 and RXDA2 pins in advance, using the PMC3, PFC3, and PFCE3 registers. When using UARTA2 at P311 and P312, specify P311 and P312 as the TXDA2 and RXDA2 pins in advance, using the PMC3 register.

SDA00 and SCL00 (serial transmission/reception data/serial clock pins) of I<sup>2</sup>C00 and SIE2 and SCKB2 (serial reception data/serial clock pins) of CSIB2 are alternate functions of both P38 and P39. By using UARTA2 at P311 and P312, these alternate functions can be used simultaneously with UARTA2.

**(4) UARTA3**

The transmission/reception pins (TXDA3 and RXDA3) of UARTA3 are assigned to P81 and P80, respectively. When using UARTA3, specify P81 and P80 as the TXDA3 and RXDA3/INTP8 pins in advance, using the PMC8, PFC8, and PFCE8 registers. Furthermore, disable the edge detection of the INTP8 pin at P80 (INTF8.INTF80 bit = 0, INTR8.INTR80 bit = 0).

The TXDA3 and RXDA3 pins and the clock output pins (RC1CKO, RC1CKDIV, and RC1CK1HZ) of RTC are alternate functions of the same pin, and therefore cannot be used simultaneously. In addition, the TXDA3 and RXDA3 pins also function alternately as the INTP8 pin (external interrupt input), so use the INTP8 pin assigned to another port pin (P93) when using the RXDA3, TXDA pins and the INTP8 pin simultaneously.

**(5) UARTA4**

The transmission/reception pins (TXDA4 and RXDA4) of UARTA4 are assigned to two port pins P61, P60 and P57, P56, respectively, and can be used at either one of the two port pins only. When using UARTA4 at P61 and P60, specify P61 and P60 as the TXDA4 and RXDA4 pins in advance, using the PMC6, PFC6, and PFCE6 registers. When using UARTA4 at P57 and P56, specify P57 and P56 as the TXDA4 and RXDA4 pins in advance, using the PMC5 register.

SOE0 and SIE0 (transmission/reception pins) and RTP11 and RTP10 (real-time output pins) are alternate functions of both P61 and P60. By using UARTA4 at P57 and P56, these alternate functions can be used simultaneously with UARTA4.

**(6) UARTA5**

The transmission/reception pins (TXDA5 and RXDA5) of UARTA5 are assigned to two port pins P68, P67 and P85, P84, respectively, and can be used at either one of the two port pins only. When using UARTA5 at P68 and P67, specify P68 and P67 as the TXDA5 and RXDA5 pins in advance, using the PMC6, PFC6, and PFCE6 registers. When using UARTA5 at P85 and P84, specify P85 and P84 as the TXDA5 and RXDA5 pins in advance, using the PMC8 register.

SCKB5 and SOB5 (serial clock/serial transmission data pins) of CSIB5 and SCL05 and SDA05 (serial clock/serial transmission/reception data pins) of I<sup>2</sup>C05 are alternate functions of both P68 and P67. By using UARTA5 at P85 and P84, these alternate functions can be used simultaneously with UARTA5.

**Caution** Do not switch port settings during operation. Also, be sure to disable operation of unused units for which port settings are not made.

## 15.2 Features

- Transfer rate: 300 bps to 625 kbps (using dedicated baud rate generator)
- Full-duplex communication: Internal UARTAn receive data register (UAnRX)  
Internal UARTAn transmit data register (UAnTX)
- 2-pin configuration: TXDAn: Transmit data output pin  
RXDAn: Receive data input pin
- Reception error output function
  - Parity error
  - Framing error
  - Overrun error
- Interrupt sources: 2
  - Reception completion interrupt (INTUAnR): This interrupt occurs upon transfer of receive data from the receive shift register to UAnRX register after serial transfer completion, in the reception enabled status.
  - Transmission enable interrupt (INTUAnT): This interrupt occurs upon transfer of transmit data from the UAnTX register to the transmit shift register in the transmission enabled status.
- Character length: 7 or 8 bits
- Parity function: Odd, even, 0, none
- Transmission stop bit: 1 or 2 bits
- On-chip dedicated baud rate generator
- MSB-/LSB-first transfer selectable
- Transmit/receive data inverted input/output possible
- SBF (Sync Break Field) transmission/reception in the LIN (Local Interconnect Network) communication format possible
  - 13 to 20 bits selectable for SBF transmission
  - Recognition of 11 bits or more possible for SBF reception
  - SBF reception flag provided

**Remark** n = 0 to 5

### 15.3 Configuration

The block diagram of the UARTAn is shown below.

**Figure 15-1. Block Diagram of Asynchronous Serial Interface An**

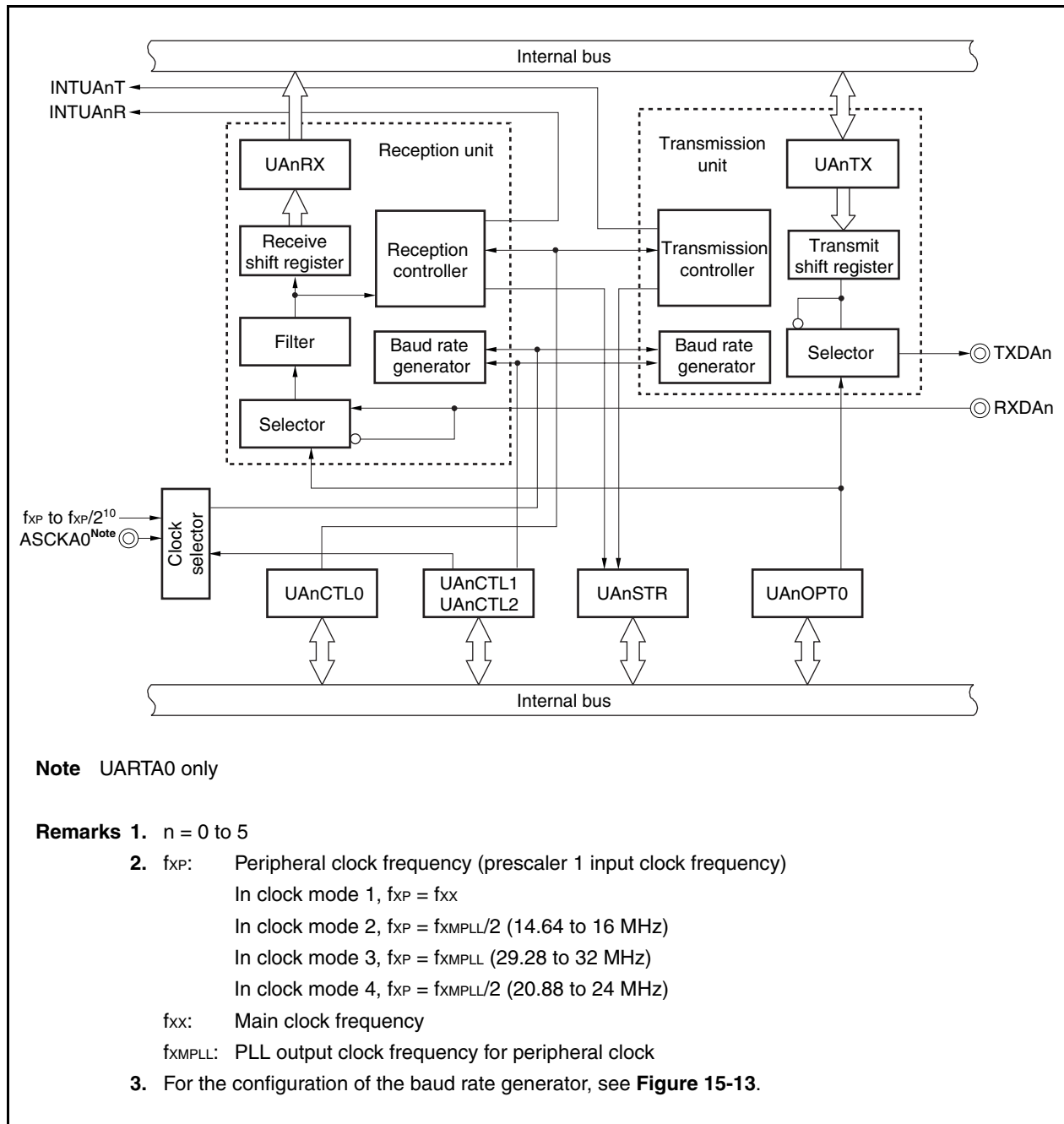

UARTAn consists of the following hardware units.

**Table 15-3. Configuration of UARTAn**

Item	Configuration
Registers	UARTAn control register 0 (UAnCTL0) UARTAn control register 1 (UAnCTL1) UARTAn control register 2 (UAnCTL2) UARTAn option control register 0 (UAnOPT0) UARTAn status register (UAnSTR) UARTAn receive shift register UARTAn receive data register (UAnRX) UARTAn transmit shift register UARTAn transmit data register (UAnTX)

**(1) UARTAn control register 0 (UAnCTL0)**

The UAnCTL0 register is an 8-bit register used to specify the UARTAn operation.

**(2) UARTAn control register 1 (UAnCTL1)**

The UAnCTL1 register is an 8-bit register used to select the input clock for the UARTAn.

**(3) UARTAn control register 2 (UAnCTL2)**

The UAnCTL2 register is an 8-bit register used to control the baud rate for the UARTAn.

**(4) UARTAn option control register 0 (UAnOPT0)**

The UAnOPT0 register is an 8-bit register used to control serial transfer for the UARTAn.

**(5) UARTAn status register (UAnSTR)**

The UAnSTRn register consists of flags indicating the error contents when a reception error occurs. Each one of the reception error flags is set (to 1) upon occurrence of a reception error.

**(6) UARTAn receive shift register**

This is a shift register used to convert the serial data input to the RXDAn pin into parallel data. Upon reception of 1 byte of data and detection of the stop bit, the receive data is transferred to the UAnRX register.

This register cannot be manipulated directly.

**(7) UARTAn receive data register (UAnRX)**

The UAnRX register is an 8-bit register that holds receive data. When 7 characters are received, 0 is stored in the highest bit (when data is received LSB first).

In the reception enabled status, receive data is transferred from the UARTAn receive shift register to the UAnRX register in synchronization with the completion of shift-in processing of 1 frame.

Transfer to the UAnRX register also causes the reception completion interrupt request signal (INTUAnR) to be output.

**(8) UARTAn transmit shift register**

The transmit shift register is a shift register used to convert the parallel data transferred from the UAnTX register into serial data.

When 1 byte of data is transferred from the UAnTX register, the shift register data is output from the TXDAn pin. This register cannot be manipulated directly.

**(9) UARTAn transmit data register (UAnTX)**

The UAnTX register is an 8-bit transmit data buffer. Transmission starts when transmit data is written to the UAnTX register. When data can be written to the UAnTX register (when data of one frame is transferred from the UAnTX register to the UARTAn transmit shift register), the transmission enable interrupt request signal (INTUAnT) is generated.

## 15.4 Registers

### (1) UARTAn control register 0 (UAnCTL0)

The UAnCTL0 register is an 8-bit register that controls the UARTAn serial transfer operation.

This register can be read or written in 8-bit or 1-bit units.

Reset sets this register to 10H.

(1/2)

After reset: 10H								R/W	Address: UA0CTL0 FFFFFFFA00H, UA1CTL0 FFFFFFFA10H, UA2CTL0 FFFFFFFA20H, UA3CTL0 FFFFFFFA30H, UA4CTL0 FFFFFFFA40H, UA5CTL0 FFFFFFFA50H							
	<7>	<6>	<5>	<4>	3	2	1	0								
UAnCTL0	UAnPWR	UAnTXE	UAnRXE	UAnDIR	UAnPS1	UAnPS0	UAnCL	UAnSL								
(n = 0 to 5)																
UAnPWR	UARTAn operation control															
0	Disable UARTAn operation (UARTAn reset asynchronously)															
1	Enable UARTAn operation															
The UARTAn operation is controlled by the UAnPWR bit. The TXDAn pin output is fixed to high level by clearing the UAnPWR bit to 0 (fixed to low level if UAnOPT0.UAnTDL bit = 1).																
UAnTXE	Transmission operation enable															
0	Disable transmission operation															
1	Enable transmission operation															
<ul style="list-style-type: none"> <li>• To start transmission, set the UAnPWR bit to 1 and then set the UAnTXE bit to 1.</li> <li>• To initialize the transmission unit, clear the UAnTXE bit to 0, wait for two cycles of the base clock (<math>f_{CLK}</math>), and then set the UAnTXE bit to 1 again. Otherwise, initialization may not be executed (for the base clock, see <b>15.7 (1) (a) Base clock</b>).</li> <li>• When the operation is enabled (UAnPWR bit = 1), the transmission operation is enabled after two or more cycles of the base clock (<math>f_{CLK}</math>) have elapsed since UAnTXE = 1.</li> <li>• When the UAnPWR bit is cleared to 0, the status of the internal circuit becomes the same status as UAnTXE bit = 0 by the UAnPWR bit even if the UAnTXE bit is 1. The transmission operation is enabled when the UAnPWR bit is set to 1 again.</li> </ul>																

UAnRXE	Reception operation enable
0	Disable reception operation
1	Enable reception operation

- To start reception, set the UAnPWR bit to 1 and then set the UAnRXE bit to 1.
- To initialize the reception unit, clear the UAnRXE bit to 0, wait for two cycles of the base clock, and then set the UAnRXE bit to 1 again. Otherwise, initialization may not be executed (for the base clock, see **15.7 (1) (a) Base clock**).
- When the operation is enabled (UAnPWR bit = 1), the reception operation is enabled after two or more cycles of the base clock ( $f_{CLK}$ ) have elapsed since UAnRXE = 1. If the start bit is received before the reception operation is enabled, the start bit is ignored.
- When the UAnPWR bit is cleared to 0, the status of the internal circuit becomes the same status as UAnRXE bit = 0 by the UAnPWR bit even if the UAnRXE bit is 1. The reception operation is enabled when the UAnPWR bit is set to 1 again.

UAnDIR <sup>Note</sup>	Transfer direction selection
0	MSB-first transfer
1	LSB-first transfer

UAnPS1 <sup>Note</sup>	UAnPS0 <sup>Note</sup>	Parity selection during transmission	Parity selection during reception
0	0	No parity output	Reception with no parity
0	1	0 parity output	Reception with 0 parity
1	0	Odd parity output	Odd parity check
1	1	Even parity output	Even parity check

- If “Reception with 0 parity” is selected during reception, a parity check is not performed. Therefore, the UAnSTR.UAnPE bit is not set.
- When transmission and reception are performed in the LIN format, clear the UAnPS1 and UAnPS0 bits to 00.

UAnCL <sup>Note</sup>	Specification of data character length of 1 frame of transmit/receive data
0	7 bits
1	8 bits

UAnSL <sup>Note</sup>	Specification of length of stop bit for transmit data
0	1 bit
1	2 bits

Only the first bit of the receive data stop bits is checked, regardless of the value of the UAnSL bit.

**Note** This register can be rewritten only when the UAnPWR bit = 0 or the UAnTXE bit = UAnRXE bit = 0. However, setting any or all of the UAnPWR, UAnTXE, and UAnRXE bits to 1 at the same time is possible.

**Remark** For details of parity, see **15.6.9 Parity types and operations**.



**(2) UARTAn control register 1 (UAnCTL1)**

For details, see 15.7 (2) **UARTAn control register 1 (UAnCTL1)**.

**(3) UARTAn control register 2 (UAnCTL2)**

For details, see 15.7 (3) **UARTAn control register 2 (UAnCTL2)**.

**(4) UARTAn option control register 0 (UAnOPT0)**

The UAnOPT0 register is an 8-bit register that controls the serial transfer operation of the UARTAn register. This register can be read or written in 8-bit or 1-bit units. The UAnSRF bit is a read-only bit. Reset sets this register to 14H.

**Caution** Do not set the UAnSRT and UAnSTT bits (to 1) during SBF reception (UAnSRF bit = 1).

(1/2)

After reset: 14H    R/W    Address: UA0OPT0 FFFFFFFA03H, UA1OPT0 FFFFFFFA13H,  
 UA2OPT0 FFFFFFFA23H, UA3OPT0 FFFFFFFA33H,  
 UA4OPT0 FFFFFFFA43H, UA5OPT0 FFFFFFFA53H

	$\langle 7 \rangle$	6	5	4	3	2	1	0
UAnOPT0 (n = 0 to 5)	UAnSRF	UAnSRT	UAnSTT	UAnSLS2	UAnSLS1	UAnSLS0	UAnTDL	UAnRDL

UAnSRF	SBF reception flag
0	When the UAnCTL0.UAnPWR bit = UAnCTL0.UAnRXE bit = 0 are set. Also upon normal end of SBF reception.
1	During SBF reception
<ul style="list-style-type: none"> <li>• SBF (Sync Brake Field) reception is judged during LIN communication.</li> <li>• The UAnSRF bit is held at 1 when an SBF reception error occurs, and then SBF reception is started again.</li> </ul>	

UAnSRT	SBF reception trigger
0	-
1	SBF reception trigger
<ul style="list-style-type: none"> <li>• This is the SBF reception trigger bit during LIN communication, and when read, "0" is always read. For SBF reception, set the UAnSRT bit (to 1) to enable SBF reception.</li> <li>• Set the UAnSRT bit after setting both the UAnPWR bit and UAnRXE bit to 1.</li> <li>• Set the UAnSRT bit (to 1) during a period of 1 bit after the reception end interrupt request signal (INTUANr) has been generated. (If this bit is set (to 1) during reception operation, the UAnSRF bit is cleared when reception of the current data is completed, even if SBF is not received.)</li> <li>• Writing 0 to the UAnSRT bit is valid. If 0 is written to the UAnSRT bit before SBF reception is started, therefore, SBF is not received but normal UART reception is executed.</li> </ul> <p>If 0 is written to the UAnOPT0 register during SBF reception, data that has already been received is received as SBF. If the data being received is not SBF, however, the following data operate as the receive data of UART, starting from the next receive data.</p> <p>The UAnSRF bit is cleared when 0 is written to the UAnSRT bit.</p>	

UAnSTT	SBF transmission trigger
0	–
1	SBF transmission trigger

- This is the SBF transmission trigger bit during LIN communication, and when read, “0” is always read.
- Set the UAnSTT bit after setting the UAnPWR bit = UAnTXE bit = 1.
- Writing 0 to the UAnSTT bit is valid. If 0 is written to this bit after 1 has been written to it and before it is sampled with the base clock, SBF transmission is therefore not executed. If 0 is written to the UAnSTT bit during SBF transmission, the UAnSTR.UAnTSF bit is cleared to 0 even though SBF transmission is executed.

UAnSLS2	UAnSLS1	UAnSLS0	SBF transmit length selection
1	0	1	13-bit output (reset value)
1	1	0	14-bit output
1	1	1	15-bit output
0	0	0	16-bit output
0	0	1	17-bit output
0	1	0	18-bit output
0	1	1	19-bit output
1	0	0	20-bit output

This register can be set when the UAnPWR bit = 0 or when the UAnTXE bit = 0.

UAnTDL	Transmit data level bit
0	Normal output of transfer data
1	Inverted output of transfer data

- The output level of the TXDAn pin can be inverted using the UAnTDL bit.
- This register can be set when the UAnPWR bit = 0 or when the UAnTXE bit = 0.

UAnRDL	Receive data level bit
0	Normal input of transfer data
1	Inverted input of transfer data

- The input level of the RXDAn pin can be inverted using the UAnRDL bit.
- This register can be set when the UAnPWR bit = 0 or the UAnRXE bit = 0.
- When the UAnRDL bit is set to 1 (inverted input of receive data), reception must be enabled (UAnCTL0.UAnRXE bit = 1) after setting the data reception pin to the UART reception pin (RXDAn) when reception is started. When the pin mode is changed after reception is enabled, the start bit will be mistakenly detected if the pin level is high.

**(5) UARTAn status register (UAnSTR)**

The UAnSTR register is an 8-bit register that displays the UARTAn transfer status and reception error contents. This register can be read or written in 8-bit or 1-bit units, but the UAnTSF bit is a read-only bit, while the UAnPE, UAnFE, and UAnOVE bits can both be read and written. However, these bits can only be cleared by writing 0; they cannot be set by writing 1 (even if 1 is written to them, the value is retained).

The initialization conditions are shown below.

Register/Bit	Initialization Conditions
UAnSTR register	<ul style="list-style-type: none"> <li>• Reset</li> <li>• UAnCTL0.UAnPWR = 0</li> </ul>
UAnTSF bit	<ul style="list-style-type: none"> <li>• UAnCTL0.UAnTXE = 0</li> </ul>
UAnPE, UAnFE, UAnOVE bits	<ul style="list-style-type: none"> <li>• 0 write</li> <li>• UAnCTL0.UAnRXE = 0</li> </ul>

**Caution** Be sure to read the error flags of the UAnPE, UAnFE, and UAnOVE bits to check the flag status, and then clear the flags by writing “0” to them.

After reset: 00H R/W Address: UA0STR FFFFFFFA04H, UA1STR FFFFFFFA14H,  
 UA2STR FFFFFFFA24H, UA3STR FFFFFFFA34H,  
 UA4STR FFFFFFFA44H, UA5STR FFFFFFFA54H

	<7>	6	5	4	3	<2>	<1>	<0>
UAnSTR (n = 0 to 5)	UAnTSF	0	0	0	0	UAnPE	UAnFE	UAnOVE

UAnTSF	Transfer status flag
0	<ul style="list-style-type: none"> <li>When the UAnPWR bit = 0 or the UAnTXE bit = 0 has been set.</li> <li>When, following transfer completion, there was no next data transfer from UAnTX register</li> </ul>
1	Write to UAnTX register
<p>The UAnTSF bit is always 1 when performing continuous transmission. When initializing the transmission unit, check that the UAnTSF bit = 0 before performing initialization. The transmit data is not guaranteed when initialization is performed while the UAnTSF bit = 1.</p>	

UAnPE	Parity error flag
0	<ul style="list-style-type: none"> <li>When the UAnPWR bit = 0 or the UAnRXE bit = 0 has been set.</li> <li>When 0 has been written</li> </ul>
1	When parity of data and parity bit do not match during reception.
<ul style="list-style-type: none"> <li>The operation of the UAnPE bit is controlled by the settings of the UAnCTL0.UAnPS1 and UAnCTL0.UAnPS0 bits.</li> <li>The UAnPE bit can be read and written, but it can only be cleared by writing 0 to it, and it cannot be set by writing 1 to it. When 1 is written to this bit, the value is retained.</li> </ul>	

UAnFE	Framing error flag
0	<ul style="list-style-type: none"> <li>When the UAnPWR bit = 0 or the UAnRXE bit = 0 has been set</li> <li>When 0 has been written</li> </ul>
1	When no stop bit is detected during reception
<ul style="list-style-type: none"> <li>Only the first bit of the receive data stop bits is checked, regardless of the value of the UAnCTL0.UAnSL bit.</li> <li>The UAnFE bit can be both read and written, but it can only be cleared by writing 0 to it, and it cannot be set by writing 1 to it. When 1 is written to this bit, the value is retained.</li> </ul>	

UAnOVE	Overrun error flag
0	<ul style="list-style-type: none"> <li>When the UAnPWR bit = 0 or the UAnRXE bit = 0 has been set.</li> <li>When 0 has been written</li> </ul>
1	When receive data has been set to the UAnRX register and the next receive operation is completed before that receive data has been read
<ul style="list-style-type: none"> <li>When an overrun error occurs, the data is discarded without the next receive data being written to the UAnRX register.</li> <li>The UAnOVE bit can be both read and written, but it can only be cleared by writing 0 to it. When 1 is written to this bit, the value is retained.</li> </ul>	

**Caution** Be sure to set bits 3 to 6 to “0”.

**(6) UARTAn receive data register (UAnRX)**

The UAnRX register is an 8-bit buffer register that stores parallel data converted by the receive shift register.

The data stored in the receive shift register is transferred to the UAnRX register upon completion of reception of 1 byte of data. The reception end interrupt request signal (INTUAnR) is generated in this timing.

During LSB-first reception when the data length has been specified as 7 bits, the receive data is transferred to bits 6 to 0 of the UAnRX register and the MSB always becomes 0. During MSB-first reception, the receive data is transferred to bits 7 to 1 of the UAnRX register and the LSB always becomes 0.

When an overrun error (UAnOVE) occurs, the receive data at this time is not transferred to the UAnRX register and is discarded.

This register is read-only, in 8-bit units.

In addition to reset input, the UAnRX register can be set to FFH by clearing the UAnCTL0.UAnPWR bit to 0.

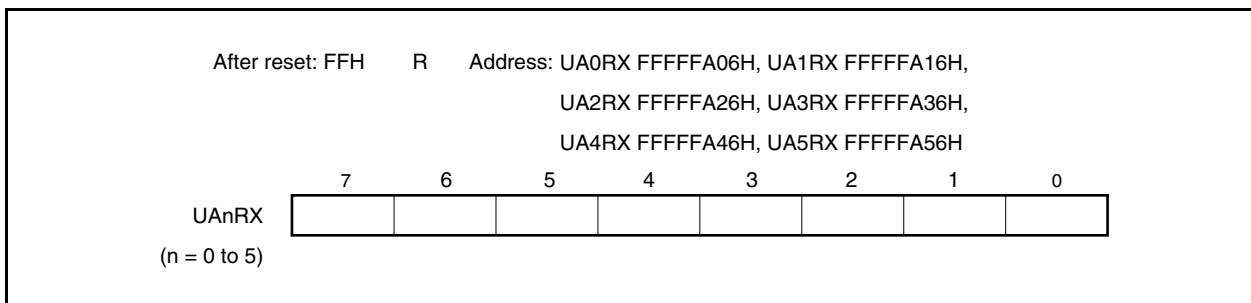
**(7) UARTAn transmit data register (UAnTX)**

The UAnTX register is an 8-bit register used to set transmit data.

Transmission starts when transmit data is written to the UAnTX register in the transmission enabled status (UAnCTL0.UAnTXE bit = 1). When the data of the UAnTX register has been transferred to the transmit shift register, the transmission enable interrupt request signal (INTUAnT) is generated.

This register can be read or written in 8-bit units.

Reset sets this register to FFH.

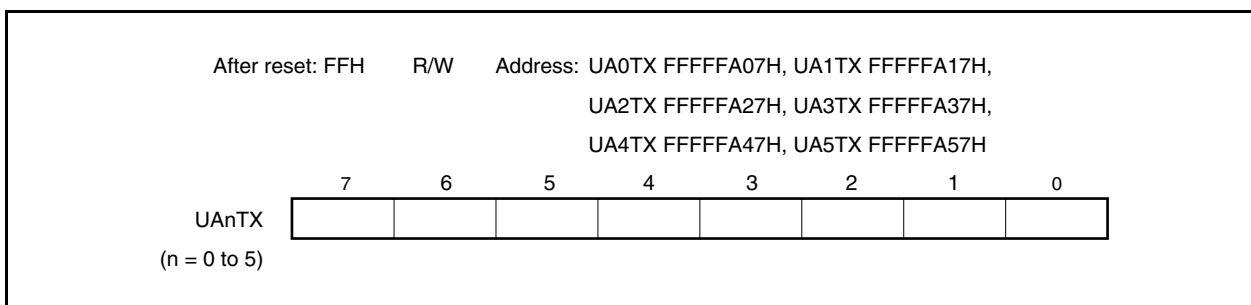

## 15.5 Interrupt Request Signals

The following two interrupt request signals are generated from UARTAn.

- Reception completion interrupt request signal (INTUAnR)
- Transmission enable interrupt request signal (INTUAnT)

The default priority for these two interrupt request signals is reception completion interrupt request signal then transmission enable interrupt request signal.

**Table 15-4. Interrupts and Their Default Priorities**

Interrupt	Priority
Reception complete	High
Transmission enable	Low

### (1) Reception completion interrupt request signal (INTUAnR)

A reception completion interrupt request signal is output when data is shifted into the receive shift register and transferred to the UAnRX register in the reception enabled status.

When a reception completion interrupt request signal is received and the data is read, read the UAnSTR register and check that the reception result is not an error.

No reception completion interrupt request signal is generated in the reception disabled status.

### (2) Transmission enable interrupt request signal (INTUAnT)

If transmit data is transferred from the UAnTX register to the UARTAn transmit shift register with transmission enabled, the transmission enable interrupt request signal is generated.

## 15.6 Operation

### 15.6.1 Data format

Full-duplex serial data reception and transmission is performed.

As shown in Figure 15-2, one data frame of transmit/receive data consists of a start bit, character bits, parity bit, and stop bit(s).

Specification of the character bit length within 1 data frame, parity selection, specification of the stop bit length, and specification of MSB/LSB-first transfer are performed using the UAnCTL0 register.

Moreover, control of UART output/inverted output for the TXDAn bit is performed using the UAnOPT0.UAnTDL bit.

- Start bit ..... 1 bit
- Character bits..... 7 bits/8 bits
- Parity bit ..... Even parity/odd parity/0 parity/no parity
- Stop bit..... 1 bit/2 bits

Figure 15-2. UARTA Transmit/Receive Data Format

(a) 8-bit data length, LSB first, even parity, 1 stop bit, transfer data: 55H

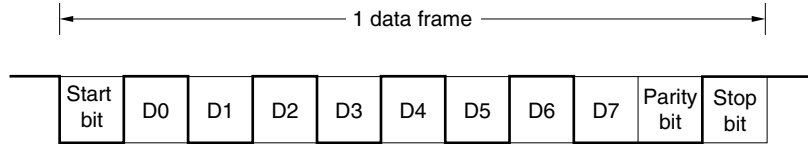

(b) 8-bit data length, MSB first, even parity, 1 stop bit, transfer data: 55H

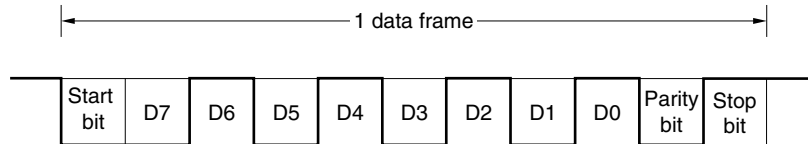

(c) 8-bit data length, MSB first, even parity, 1 stop bit, transfer data: 55H, TXDAn inversion



(d) 7-bit data length, LSB first, odd parity, 2 stop bits, transfer data: 36H

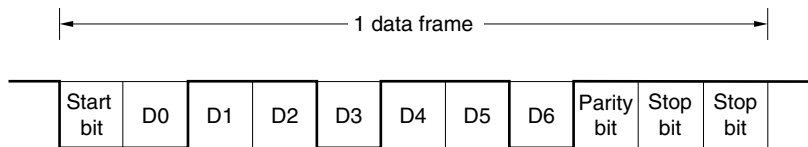

(e) 8-bit data length, LSB first, no parity, 1 stop bit, transfer data: 87H

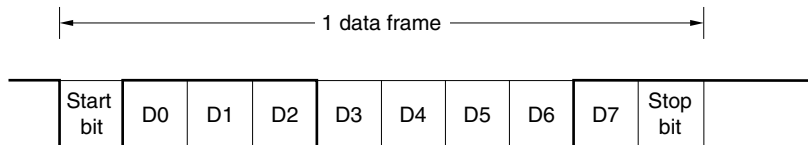



### 15.6.2 SBF transmission/reception format

The V850E/SJ3-H and V850E/SK3-H have an SBF (Sync Break Field) transmission/reception control function to enable use of the LIN function.

**Remark** LIN stands for Local Interconnect Network and is a low-speed (1 to 20 kbps) serial communication protocol intended to aid the cost reduction of an automotive network.

LIN communication is single-master communication, and up to 15 slaves can be connected to one master.

The LIN slaves are used to control the switches, actuators, and sensors, and these are connected to the LIN master via the LIN network.

Normally, the LIN master is connected to a network such as CAN (Controller Area Network).

In addition, the LIN bus uses a single-wire method and is connected to the nodes via a transceiver that complies with ISO9141.

In the LIN protocol, the master transmits a frame with baud rate information and the slave receives it and corrects the baud rate error. Therefore, communication is possible when the baud rate error in the slave is  $\pm 15\%$  or less.

Figures 15-3 and 15-4 outline the transmission and reception manipulations of LIN.

**Figure 15-3. LIN Transmission Manipulation Outline**

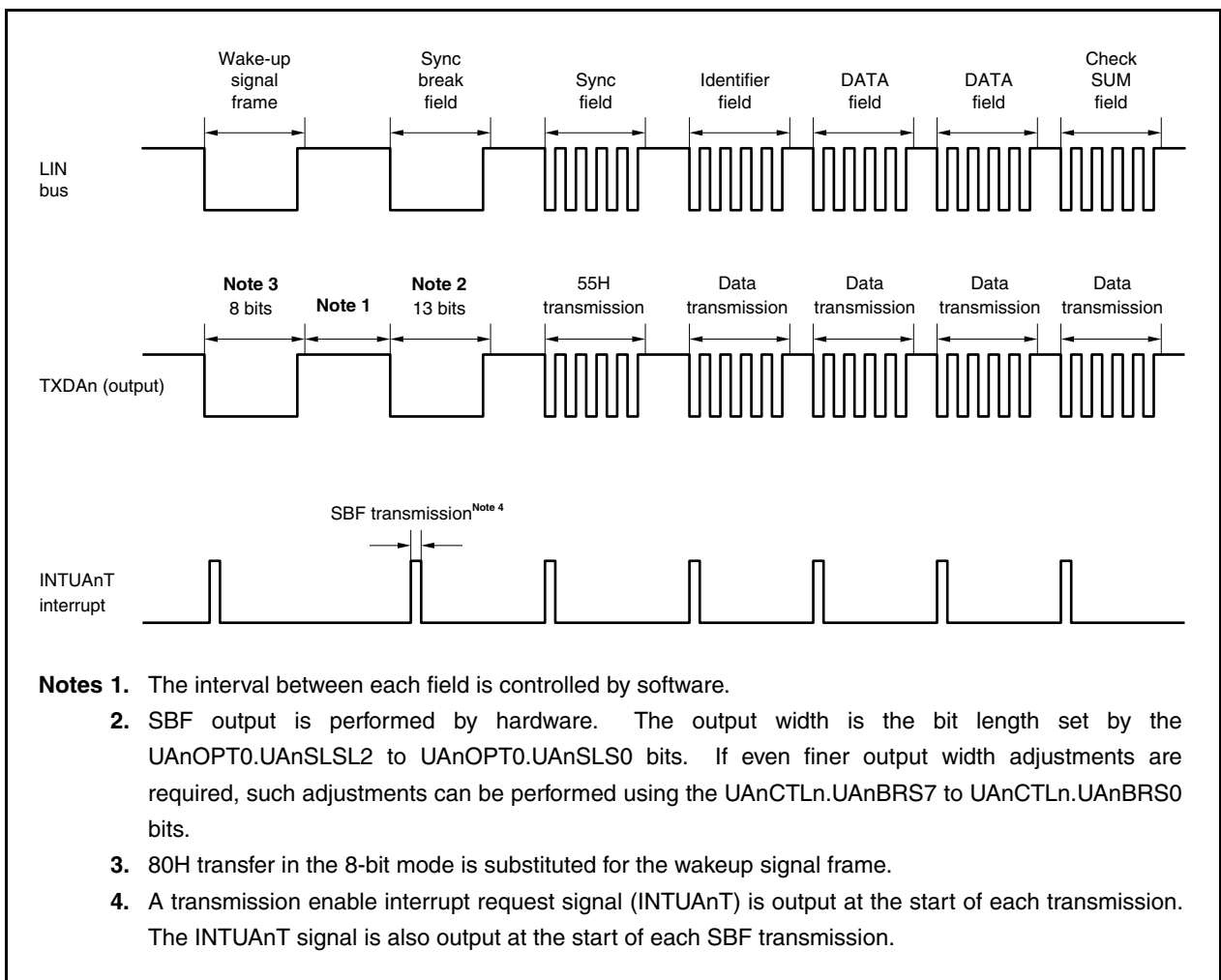
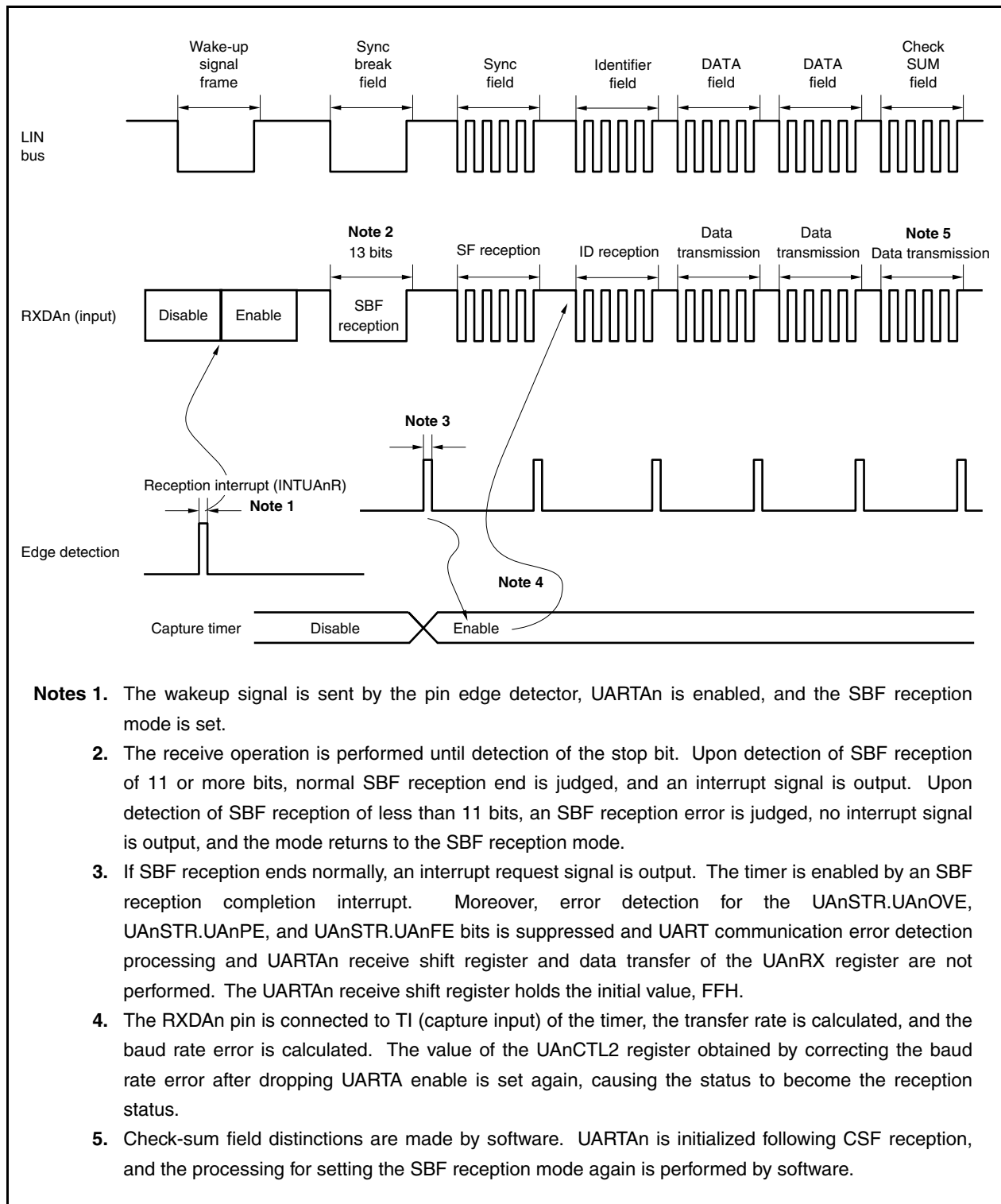

Figure 15-4. LIN Reception Manipulation Outline



### 15.6.3 SBF transmission

When the UAnCTL0.UAnPWR bit = UAnCTL0.UAnTXE bit = 1, the transmission enabled status is entered, and SBF transmission is started by setting (to 1) the SBF transmission trigger (UAnOPT0.UAnSTT bit).

Thereafter, a low level the width of bits 13 to 20 specified by the UAnOPT0.UAnSLS2 to UAnOPT0.UAnSLS0 bits is output. A transmission enable interrupt request signal (INTUAnT) is generated upon SBF transmission start. Following the end of SBF transmission, the UAnSTT bit is automatically cleared. Thereafter, the UART transmission mode is restored.

Transmission is suspended until the data to be transmitted next is written to the UAnTX register, or until the SBF transmission trigger (UAnSTT bit) is set.

Figure 15-5. SBF Transmission

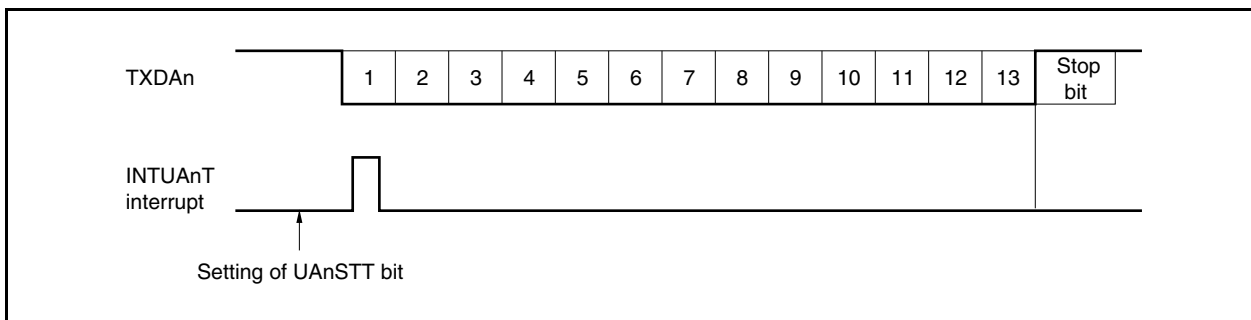

#### 15.6.4 SBF reception

The reception enabled status is achieved by setting the UAnCTL0.UAnPWR bit to 1 and then setting the UAnCTL0.UAnRXE bit to 1.

The SBF reception wait status is set by setting the SBF reception trigger (UAnOPT0.UAnSTR bit) to 1.

In the SBF reception wait status, similarly to the UART reception wait status, the RXDAn pin is monitored and start bit detection is performed.

Following detection of the start bit, reception is started and the internal counter counts up according to the set baud rate.

When a stop bit is received, if the SBF width is 11 or more bits, normal processing is judged and a reception completion interrupt request signal (INTUAnR) is output. The UAnOPT0.UAnSRF bit is automatically cleared and SBF reception ends. Error detection for the UAnSTR.UAnOVE, UAnSTR.UAnPE, and UAnSTR.UAnFE bits is suppressed and UART communication error detection processing is not performed. Moreover, data transfer of the UARTAn reception shift register and UAnRX register is not performed and FFH, the initial value, is held. If the SBF width is 10 or fewer bits, reception is terminated as error processing without outputting an interrupt, and the SBF reception mode is returned to. The UAnSRF bit is not cleared at this time.

**Caution** The LIN function does not assume that SBF is transmitted while data is being received. Consequently, if SBF is transmitted while data is being received, a framing error occurs (UAnSTR.UAnFE bit = 1).

Figure 15-6. SBF Reception

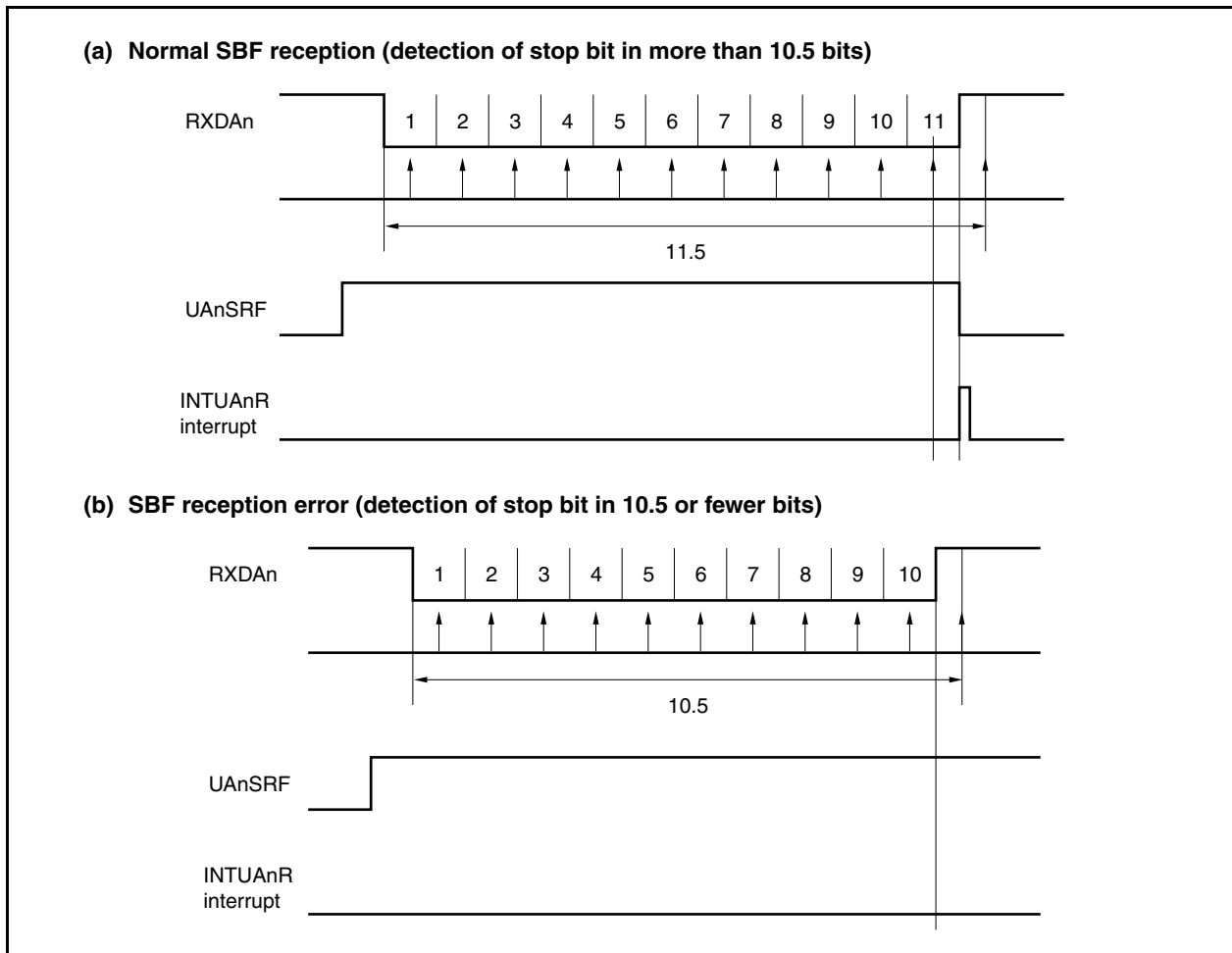

### 15.6.5 UART transmission

A high level is output to the TXDAn pin by setting the UAnCTL0.UAnPWR bit to 1.

Next, the transmission enabled status is set by setting the UAnCTL0.UAnTXE bit to 1, and transmission is started by writing transmit data to the UAnTX register. The start bit, parity bit, and stop bit are automatically added.

Since the CTS (transmit enable signal) input pin is not provided in UARTAn, use a port to check that reception is enabled at the transmit destination.

The data in the UAnTX register is transferred to the UARTAn transmit shift register upon the start of the transmit operation.

A transmission enable interrupt request signal (INTUAnT) is generated upon completion of transmission of the data of the UAnTX register to the UARTAn transmit shift register, and thereafter the contents of the UARTAn transmit shift register are output to the TXDAn pin.

Write of the next transmit data to the UAnTX register is enabled after the INTUAnT signal is generated.

**Figure 15-7. UART Transmission**

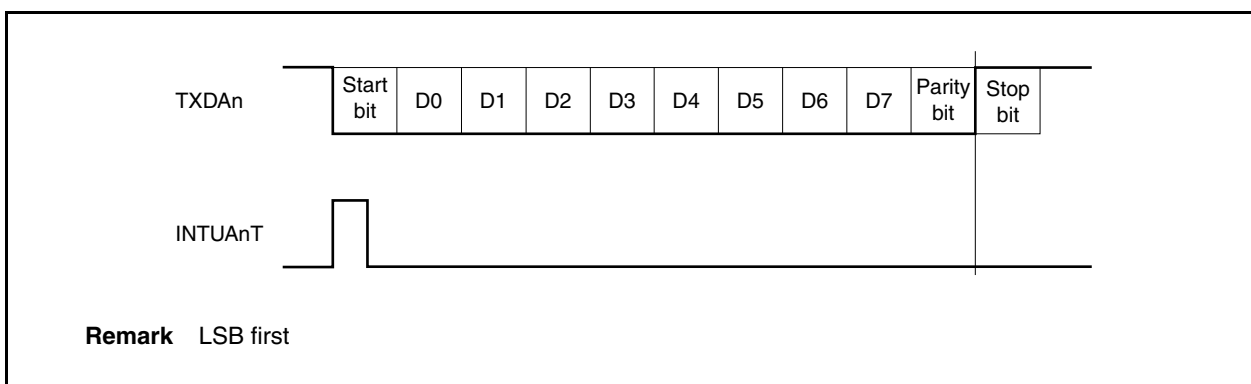

### 15.6.6 Continuous transmission procedure

UARTAn can write the next transmit data to the UAnTX register when the UARTAn transmit shift register starts the shift operation. The transmit timing of the UARTAn transmit shift register can be judged from the transmission enable interrupt request signal (INTUAnT).

An efficient communication rate is realized by writing the data to be transmitted next to the UAnTX register during transfer.

**Caution** When initializing transmissions during the execution of continuous transmissions, make sure that the UAnSTR.UAnTSF bit is 0, then perform the initialization. Transmit data that is initialized when the UAnTSF bit is 1 cannot be guaranteed.

Figure 15-8. Continuous Transmission Processing Flow

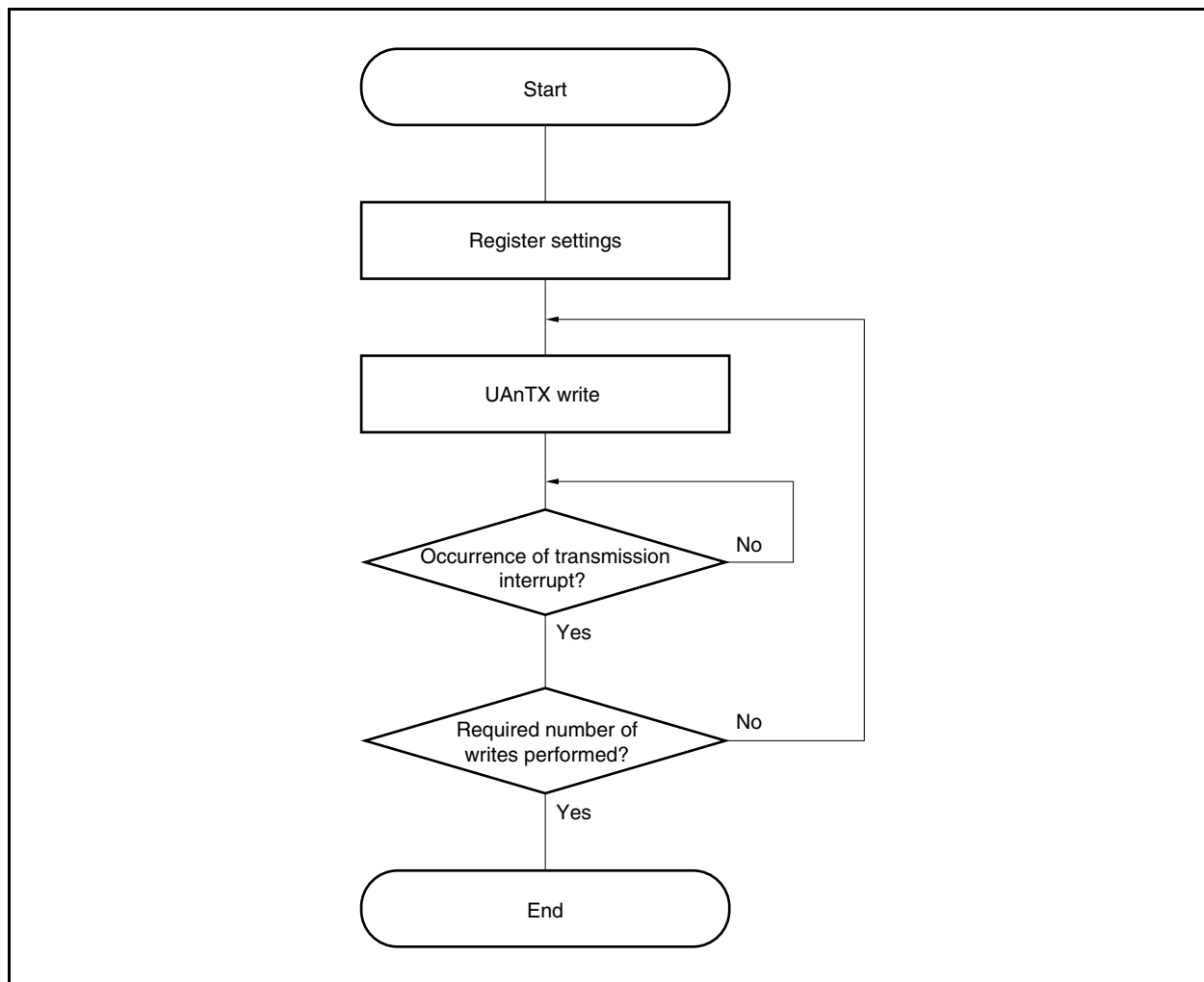
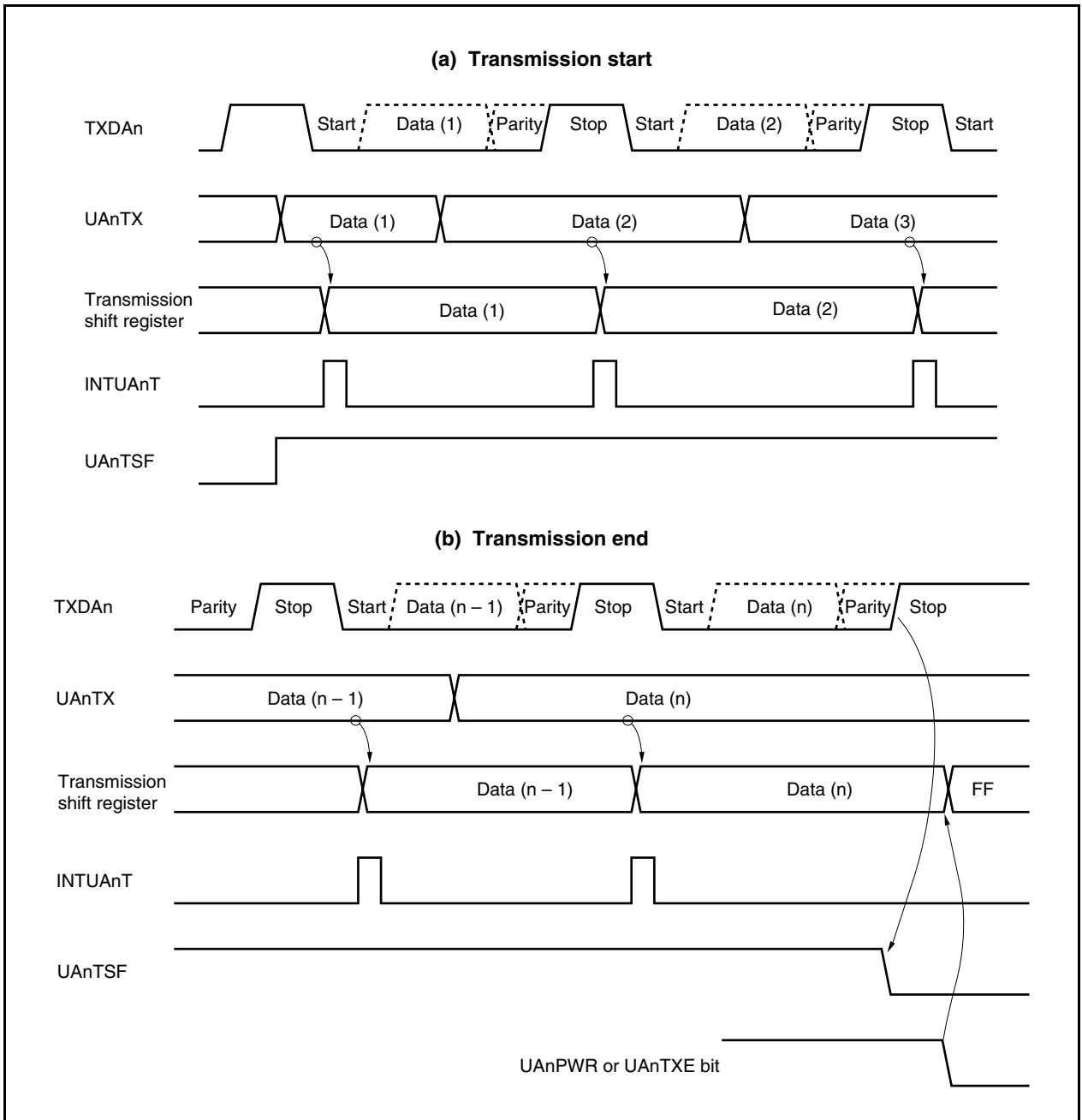

Figure 15-9. Continuous Transmission Operation Timing



### 15.6.7 UART reception

The reception wait status is set by setting the UAnCTL0.UAnPWR bit to 1 and then setting the UAnCTL0.UAnRXE bit to 1. In the reception wait status, the RXDAn pin is monitored and start bit detection is performed.

Start bit detection is performed using a two-step detection routine.

First the rising edge of the RXDAn pin is detected and sampling is started at the falling edge. The start bit is recognized if the RXDAn pin is low level at the start bit sampling point. After a start bit has been recognized, the receive operation starts, and serial data is saved to the UARTAn receive shift register according to the set baud rate.

When the reception completion interrupt request signal (INTUAnR) is output upon reception of the stop bit, the data of the UARTAn receive shift register is written to the UAnRX register. However, if an overrun error occurs (UAnSTR.UAnOVE bit = 1), the receive data at this time is not written to the UAnRX register and is discarded.

Even if a parity error (UAnSTR.UAnPE bit = 1) or a framing error (UAnSTR.UAnFE bit = 1) occurs during reception, reception continues until the reception position of the first stop bit, and INTUAnR is output following reception completion.

Figure 15-10. UART Reception

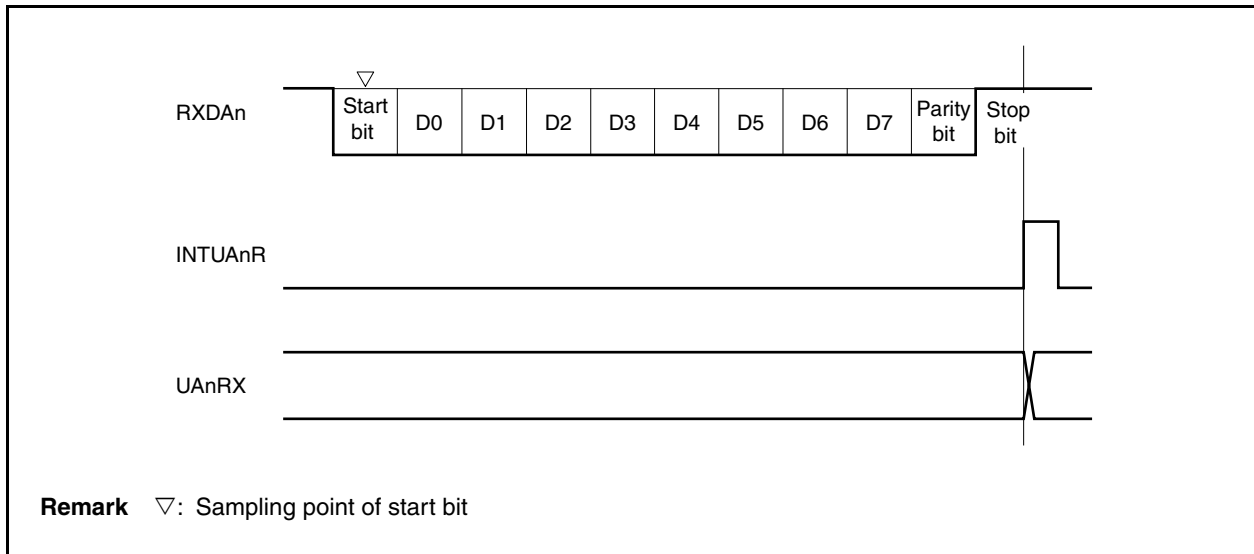

- Cautions**
1. Be sure to read the UAnRX register even when a reception error occurs. If the UAnRX register is not read, an overrun error occurs during reception of the next data, and reception errors continue occurring indefinitely.
  2. The operation during reception is performed assuming that there is only one stop bit. A second stop bit is ignored.
  3. When reception is completed, read the UAnRX register after the reception completion interrupt request signal (INTUAnR) has been generated, and clear the UAnPWR or UAnRXE bit to 0. If the UAnPWR or UAnRXE bit is cleared to 0 before the INTUAnR signal is generated, the read value of the UAnRX register cannot be guaranteed.
  4. If receive completion processing (INTUAnR signal generation) of UARTAn and the UAnPWR bit = 0 or UAnRXE bit = 0 conflict, the INTUAnR signal may be generated in spite of these being no data stored in the UAnRX register.  
To complete reception without waiting INTUAnR signal generation, be sure to clear (0) the interrupt request flag (UAnRIF) of the UAnRIC register, after setting (1) the interrupt mask flag (UAnRMK) of the interrupt control register (UAnRIC) and then set (1) the UAnPWR bit = 0 or UAnRXE bit = 0.



### 15.6.8 Reception errors

Errors during a receive operation are of three types: parity errors, framing errors, and overrun errors. Data reception result error flags are set in the UAnSTR register and a reception completion interrupt request signal (INTUAnR) is output when an error occurs.

It is possible to ascertain which error occurred during reception by reading the contents of the UAnSTR register. Clear the reception error flag by writing 0 to it after reading it.

- Receive data read flow

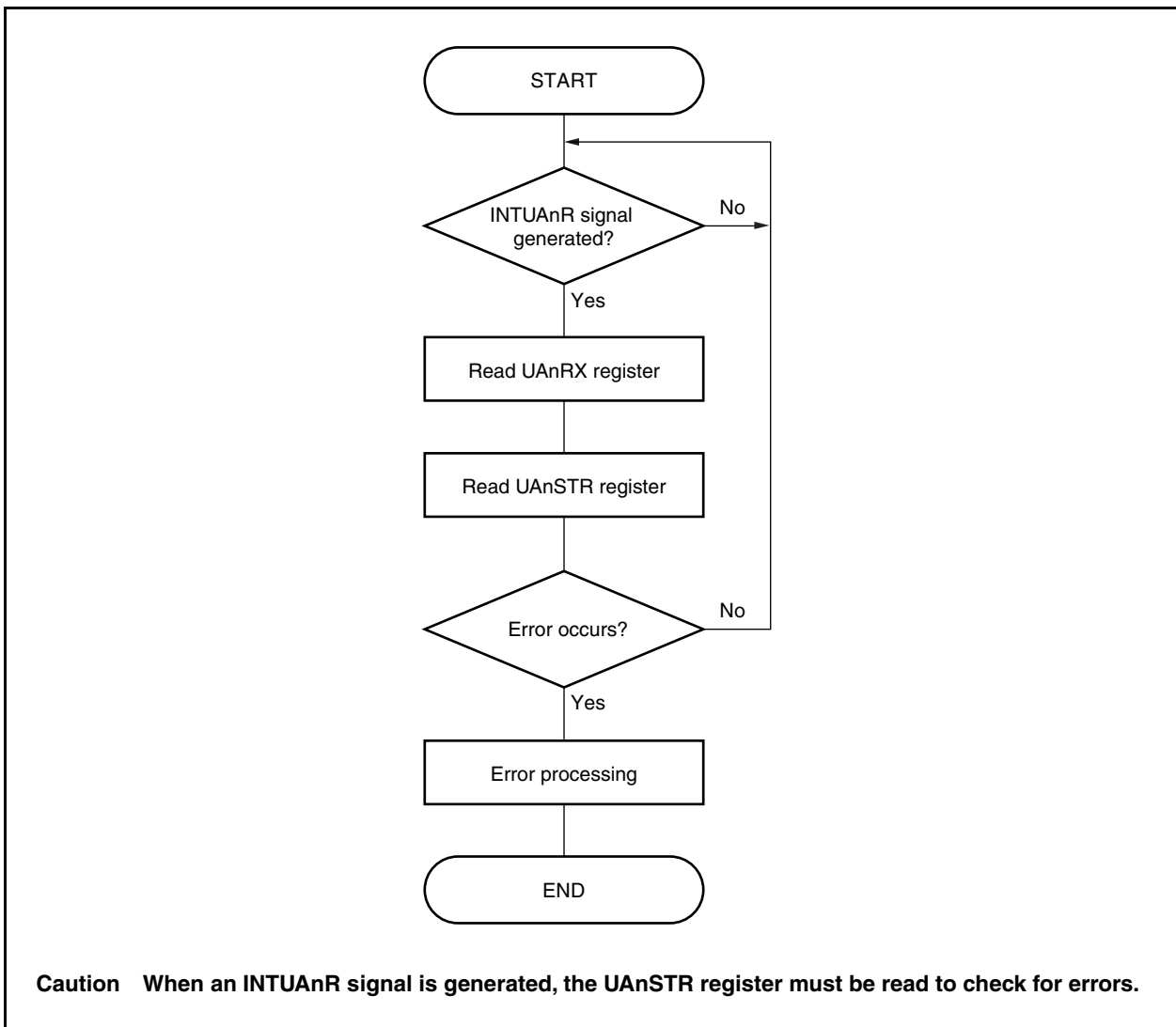

- Reception error causes

Error Flag	Reception Error	Cause
UAnPE	Parity error	Received parity bit does not match the setting
UAnFE	Framing error	Stop bit not detected
UAnOVE	Overrun error	Reception of next data completed before data was read from UAnRX register

When reception errors occur, perform the following procedures depending upon the kind of error.

- Parity error  
If false data is received due to problems such as noise in the reception line, discard the received data and retransmit.
- Framing error  
A baud rate error may have occurred between the reception side and transmission side or the start bit may have been erroneously detected. Since this is a fatal error for the communication format, check the operation stop in the transmission side, perform initialization processing each other, and then start the communication again.
- Overrun error  
Since the next reception is completed before reading receive data, 1 frame of data is discarded. If this data was needed, do a retransmission.

**Caution** If a receive error interrupt occurs during continuous reception, read the contents of the UAnSTR register must be read before the next reception is completed, then perform error processing.

### 15.6.9 Parity types and operations

**Caution** When using the LIN function, fix the UAnPS1 and UAnPS0 bits of the UAnCTL0 register to 00.

The parity bit is used to detect bit errors in the communication data. Normally the same parity is used on the transmission side and the reception side.

In the case of even parity and odd parity, it is possible to detect odd-count bit errors. In the case of 0 parity and no parity, errors cannot be detected.

#### (a) Even parity

##### (i) During transmission

The number of bits whose value is “1” among the transmit data, including the parity bit, is controlled so as to be an even number. The parity bit values are as follows.

- Odd number of bits whose value is “1” among transmit data: 1
- Even number of bits whose value is “1” among transmit data: 0

##### (ii) During reception

The number of bits whose value is “1” among the reception data, including the parity bit, is counted, and if it is an odd number, a parity error is output.

#### (b) Odd parity

##### (i) During transmission

Opposite to even parity, the number of bits whose value is “1” among the transmit data, including the parity bit, is controlled so that it is an odd number. The parity bit values are as follows.

- Odd number of bits whose value is “1” among transmit data: 0
- Even number of bits whose value is “1” among transmit data: 1

##### (ii) During reception

The number of bits whose value is “1” among the receive data, including the parity bit, is counted, and if it is an even number, a parity error is output.

#### (c) 0 parity

During transmission, the parity bit is always made 0, regardless of the transmit data.

During reception, parity bit check is not performed. Therefore, no parity error occurs, regardless of whether the parity bit is 0 or 1.

#### (d) No parity

No parity bit is added to the transmit data.

Reception is performed assuming that there is no parity bit. No parity error occurs since there is no parity bit.

**15.6.10 Receive data noise filter**

This filter samples signals received via the RXDAn pin using the base clock supplied by the dedicated baud rate generator.

When the same sampling value is read twice, the match detector output changes and the RXDAn signal is sampled as the input data. Therefore, data not exceeding 1 clock cycle width is judged to be noise and is not delivered to the internal circuit (see **Figure 15-12**). See **15.7 (1) (a) Base clock** for details of the base clock.

Moreover, since the circuit is as shown in **Figure 15-11**, the processing that goes on within the receive operation is delayed by 3 clocks in relation to the external signal status.

**Figure 15-11. Noise Filter Circuit**

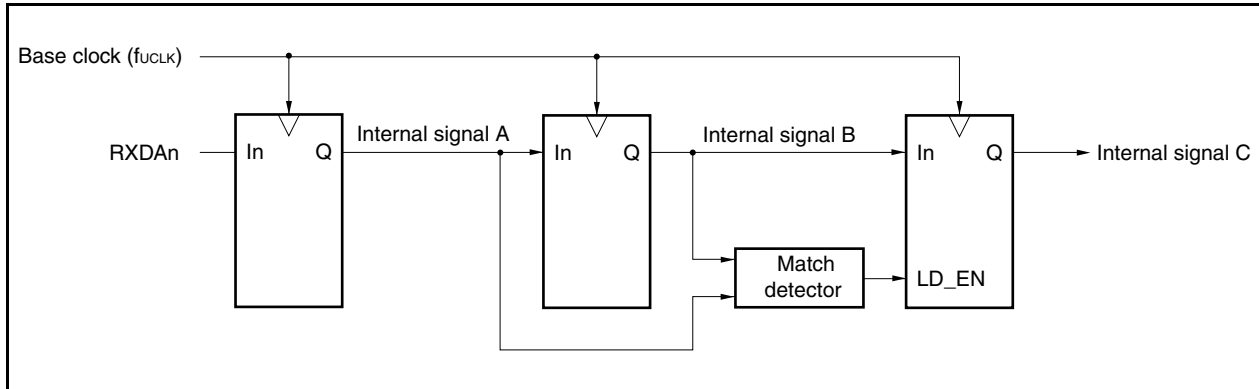

<R>

**Figure 15-12. Timing of RXDAn Signal Judged as Noise**

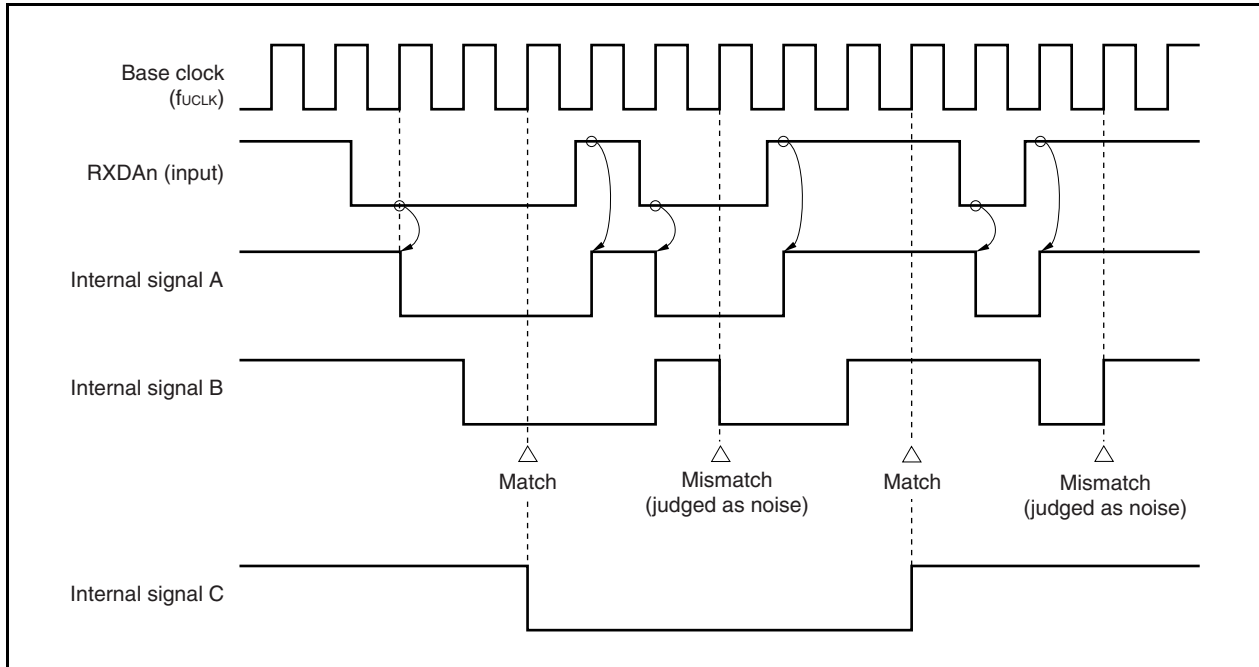

## 15.7 Dedicated Baud Rate Generator

The dedicated baud rate generator consists of a source clock selector block and an 8-bit programmable counter, and generates a serial clock during transmission and reception with UARTAn. Regarding the serial clock, a dedicated baud rate generator output can be selected for each channel.

There is an 8-bit counter for transmission and another one for reception.

### (1) Baud rate generator configuration

Figure 15-13. Configuration of Baud Rate Generator

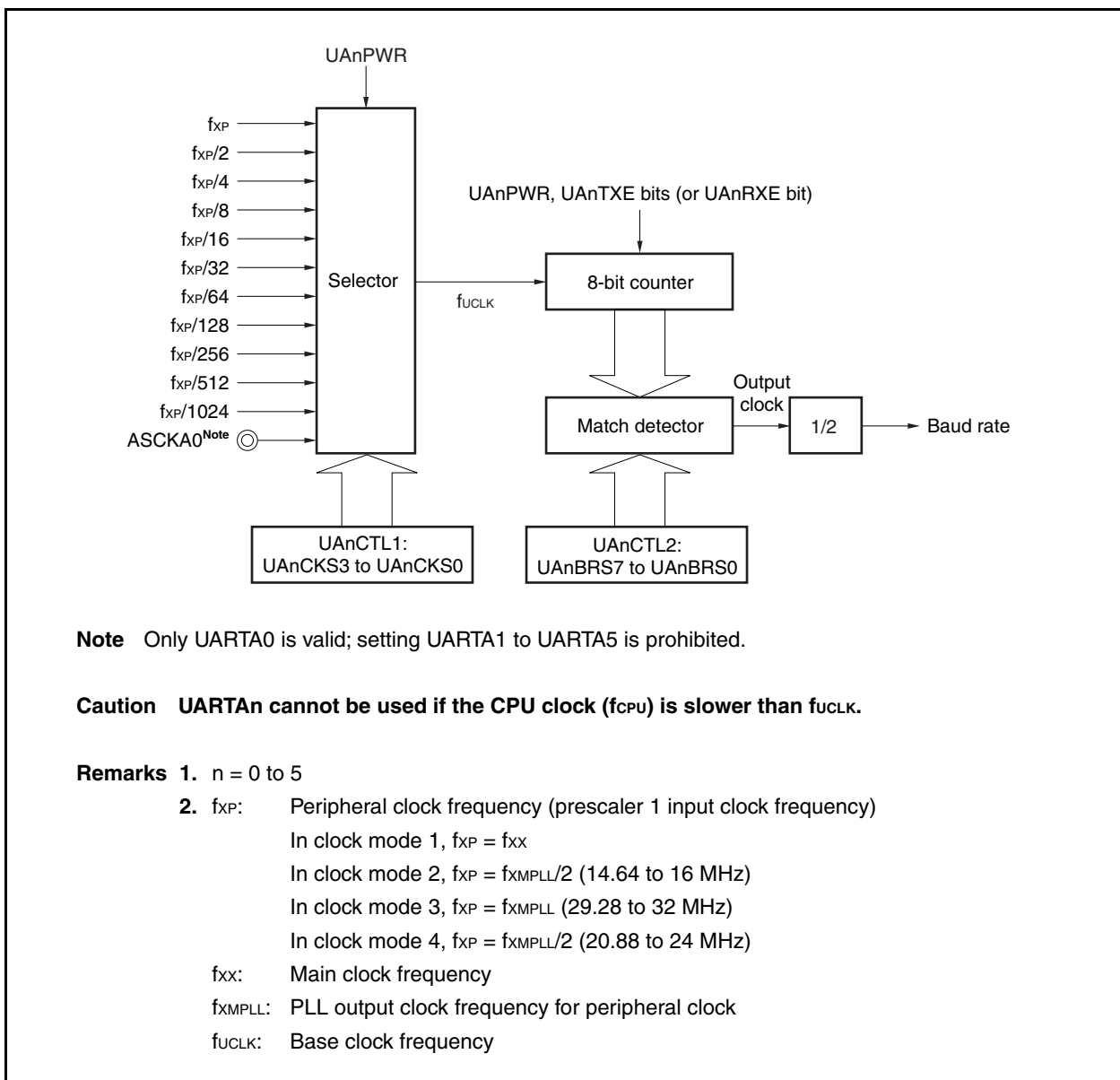

**Note** Only UARTA0 is valid; setting UARTA1 to UARTA5 is prohibited.

**Caution** UARTAn cannot be used if the CPU clock ( $f_{CPU}$ ) is slower than  $f_{UCLK}$ .

**Remarks** 1.  $n = 0$  to 5

2.  $f_{XP}$ : Peripheral clock frequency (prescaler 1 input clock frequency)

In clock mode 1,  $f_{XP} = f_{XX}$

In clock mode 2,  $f_{XP} = f_{XMPLL}/2$  (14.64 to 16 MHz)

In clock mode 3,  $f_{XP} = f_{XMPLL}$  (29.28 to 32 MHz)

In clock mode 4,  $f_{XP} = f_{XMPLL}/2$  (20.88 to 24 MHz)

$f_{XX}$ : Main clock frequency

$f_{XMPLL}$ : PLL output clock frequency for peripheral clock

$f_{UCLK}$ : Base clock frequency

**(a) Base clock**

When the UAnCTL0.UAnPWR bit is 1, the clock selected by the UAnCTL1.UAnCKS3 to UAnCTL1.UAnCKS0 bits is supplied to the 8-bit counter. This clock is called the base clock ( $f_{CLK}$ ). The base clock  $f_{CLK}$  is fixed to the low level when the UAnPWR bit is 0.

**(b) Serial clock generation**

A serial clock can be generated by setting the UAnCTL1 register and the UAnCTL2 register ( $n = 0$  to 5).

The base clock ( $f_{CLK}$ ) is selected by UAnCTL1.UAnCKS3 to UAnCTL1.UAnCKS0 bits.

The frequency division value for the 8-bit counter can be set using the UAnCTL2.UAnBRS7 to UAnCTL2.UAnBRS0 bits.

**(2) UARTAn control register 1 (UAnCTL1)**

The UAnCTL1 register is an 8-bit register that selects the UARTAn base clock.

This register can be read or written in 8-bit units.

Reset sets this register to 00H.

**Caution** Clear the UAnCTL0.UAnPWR bit to 0 before rewriting the UAnCTL1 register.

After reset: 00H    R/W    Address: UA0CTL1 FFFFFFFA01H, UA1CTL1 FFFFFFFA11H,  
 UA2CTL1 FFFFFFFA21H, UA3CTL1 FFFFFFFA31H,  
 UA4CTL1 FFFFFFFA41H, UA5CTL1 FFFFFFFA51H

	7	6	5	4	3	2	1	0
UAnCTL1	0	0	0	0	UAnCKS3	UAnCKS2	UAnCKS1	UAnCKS0

(n = 0 to 5)

UAnCKS3	UAnCKS2	UAnCKS1	UAnCKS0	Base clock (f <sub>CLK</sub> ) selection
0	0	0	0	f <sub>XP</sub>
0	0	0	1	f <sub>XP</sub> /2
0	0	1	0	f <sub>XP</sub> /4
0	0	1	1	f <sub>XP</sub> /8
0	1	0	0	f <sub>XP</sub> /16
0	1	0	1	f <sub>XP</sub> /32
0	1	1	0	f <sub>XP</sub> /64
0	1	1	1	f <sub>XP</sub> /128
1	0	0	0	f <sub>XP</sub> /256
1	0	0	1	f <sub>XP</sub> /512
1	0	1	0	f <sub>XP</sub> /1,024
1	0	1	1	External clock <sup>Note</sup> (ASCKA0 pin)
Other than above				Setting prohibited

**Note** Only UARTA0 is valid; setting UARTA1 to UARTA5 is prohibited.

**Remark** f<sub>XP</sub>: Peripheral clock frequency (prescaler 1 input clock frequency)  
 In clock mode 1, f<sub>XP</sub> = f<sub>XX</sub>  
 In clock mode 2, f<sub>XP</sub> = f<sub>XMPLL</sub>/2 (14.64 to 16 MHz)  
 In clock mode 3, f<sub>XP</sub> = f<sub>XMPLL</sub> (29.28 to 32 MHz)  
 In clock mode 4, f<sub>XP</sub> = f<sub>XMPLL</sub>/2 (20.88 to 24 MHz)

f<sub>XX</sub>: Main clock frequency  
 f<sub>XMPLL</sub>: PLL output clock frequency for peripheral clock

**(3) UARTAn control register 2 (UAnCTL2)**

The UAnCTL2 register is an 8-bit register that selects the baud rate (serial transfer speed) clock of UARTAn.

This register can be read or written in 8-bit units.

Reset sets this register to FFH.

**Caution** Clear the UAnCTL0.UAnPWR bit to 0 or clear the UAnTXE and UAnRXE bits to 00 before rewriting the UAnCTL2 register.

After reset FFH R/W Address: UA0CTL2 FFFFFFFA02H, UA1CTL2 FFFFFFFA12H,  
 UA2CTL2 FFFFFFFA22H, UA3CTL2 FFFFFFFA32H,  
 UA4CTL2 FFFFFFFA42H, UA5CTL2 FFFFFFFA52H

	7	6	5	4	3	2	1	0
UAnCTL2 (n = 0 to 5)	UAnBRS7	UAnBRS6	UAnBRS5	UAnBRS4	UAnBRS3	UAnBRS2	UAnBRS1	UAnBRS0

UAn BRS7	UAn BRS6	UAn BRS5	UAn BRS4	UAn BRS3	UAn BRS2	UAn BRS1	UAn BRS0	Default (k)	Serial clock
0	0	0	0	0	0	×	×	–	Setting prohibited
0	0	0	0	0	1	0	0	4	f <sub>uclk</sub> /4
0	0	0	0	0	1	0	1	5	f <sub>uclk</sub> /5
0	0	0	0	0	1	1	0	6	f <sub>uclk</sub> /6
:	:	:	:	:	:	:	:	:	:
1	1	1	1	1	1	0	0	252	f <sub>uclk</sub> /252
1	1	1	1	1	1	0	1	253	f <sub>uclk</sub> /253
1	1	1	1	1	1	1	0	254	f <sub>uclk</sub> /254
1	1	1	1	1	1	1	1	255	f <sub>uclk</sub> /255

**Remark** f<sub>uclk</sub>: Frequency of base clock frequency selected by the UAnCTL1.UAnCKS3 to UAnCTL1.UAnCKS0 bits



**(4) Baud rate**

The baud rate is obtained by the following equation.

$$\text{Baud rate} = \frac{f_{\text{UCLK}}}{2 \times k} \text{ [bps]}$$

When using the internal clock, the equation will be as follows (when using the ASCKA0 pin as clock at UARTA0, calculate using the above equation).

$$\text{Baud rate} = \frac{f_{\text{XP}}}{2^{m+1} \times k} \text{ [bps]}$$

**Remark**  $f_{\text{UCLK}}$  = Frequency of base clock selected by the UAnCTL1.UAnCKS3 to UAnCTL1.UAnCKS0 bits

$f_{\text{XP}}$ : Peripheral clock frequency (prescaler 1 input clock frequency)

In clock mode 1,  $f_{\text{XP}} = f_{\text{XX}}$

In clock mode 2,  $f_{\text{XP}} = f_{\text{XMPLL}}/2$  (14.64 to 16 MHz)

In clock mode 3,  $f_{\text{XP}} = f_{\text{XMPLL}}$  (29.28 to 32 MHz)

In clock mode 4,  $f_{\text{XP}} = f_{\text{XMPLL}}/2$  (20.88 to 24 MHz)

$f_{\text{XX}}$ : Main clock frequency

$f_{\text{XMPLL}}$ : PLL output clock frequency for peripheral clock

$m$  = Value set using the UAnCTL1.UAnCKS3 to UAnCTL1.UAnCKS0 bits ( $m = 0$  to  $10$ )

$k$  = Value set using the UAnCTL2.UAnBRS7 to UAnCTL2.UAnBRS0 bits ( $k = 4$  to  $255$ )

The baud rate error is obtained by the following equation.

$$\begin{aligned} \text{Error (\%)} &= \left( \frac{\text{Actual baud rate (baud rate with error)}}{\text{Target baud rate (correct baud rate)}} - 1 \right) \times 100 [\%] \\ &= \left( \frac{f_{\text{UCLK}}}{2 \times k \times \text{Target baud rate}} - 1 \right) \times 100 [\%] \end{aligned}$$

When using the internal clock, the equation will be as follows (when using the ASCKA0 pin as clock at UARTA0, calculate the baud rate error using the above equation).

$$\text{Error (\%)} = \left( \frac{f_{\text{XP}}}{2^{m+1} \times k \times \text{Target baud rate}} - 1 \right) \times 100 [\%]$$

- Cautions**
1. The baud rate error during transmission must be within the error tolerance on the receiving side.
  2. The baud rate error during reception must satisfy the range indicated in (5) Allowable baud rate range during reception.

**Remark**  $f_{\text{UCLK}}$  = Frequency of base clock selected by the UAnCTL1.UAnCKS3 to UAnCTL1.UAnCKS0 bits  
 $f_{\text{XP}}$ : Peripheral clock frequency (prescaler 1 input clock frequency)  
 In clock mode 1,  $f_{\text{XP}} = f_{\text{XX}}$   
 In clock mode 2,  $f_{\text{XP}} = f_{\text{XMPLL}}/2$  (14.64 to 16 MHz)  
 In clock mode 3,  $f_{\text{XP}} = f_{\text{XMPLL}}$  (29.28 to 32 MHz)  
 In clock mode 4,  $f_{\text{XP}} = f_{\text{XMPLL}}/2$  (20.88 to 24 MHz)  
 $f_{\text{XX}}$ : Main clock frequency  
 $f_{\text{XMPLL}}$ : PLL output clock frequency for peripheral clock  
 $m$  = Value set using the UAnCTL1.UAnCKS3 to UAnCTL1.UAnCKS0 bits ( $m = 0$  to 10)  
 $k$  = Value set using the UAnCTL2.UAnBRS7 to UAnCTL2.UAnBRS0 bits ( $k = 4$  to 255)

To set the baud rate, perform the following calculation and set the UAnCTL1 and UAnCTL2 registers (when using internal clock).

- <1> Set  $k = f_{XP}/(2 \times \text{Target baud rate})$ . Set  $m = 0$ .
- <2> Set  $k = k/2$  and  $m = m + 1$  where  $k \geq 256$ .
- <3> Repeat <2> until  $k < 256$ .
- <4> Roundup the first decimal place of  $k$ .  
If  $k = 256$  by the roundup, perform <2> again ( $k$  will become 128).
- <5> Set  $m$  to the UAnCTL1 register and  $k$  to the UAnCTL2 register.

Example: When  $f_{XP} = 32$  MHz and target baud rate = 153,600 bps

- <1>  $k = 32,000,000/(2 \times 153,600) = 104.16\dots$ ,  $m = 0$
- <2>, <3>  $k = 104.16\dots < 256$ ,  $m = 0$
- <4> Set value of UAnCTL2 register:  $k = 104 = 68H$ , set value of UAnCTL1 register:  $m = 0$

$$\begin{aligned} \text{Actual baud rate} &= 32,000,000/(2 \times 104) \\ &= 153,846 \text{ [bps]} \end{aligned}$$

$$\begin{aligned} \text{Baud rate error} &= \{32,000,000/(2 \times 104 \times 153,600) - 1\} \times 100 \\ &= 0.160 \text{ [%]} \end{aligned}$$

The representative examples of baud rate settings are shown below.

**Table 15-5. Baud Rate Generator Setting Data**

Baud Rate (bps)	$f_{XP} = 32$ MHz			$f_{XP} = 24$ MHz			$f_{XP} = 16$ MHz		
	UAnCTL1	UAnCTL2	ERR (%)	UAnCTL1	UAnCTL2	ERR (%)	UAnCTL1	UAnCTL2	ERR (%)
300	08H	D0H	0.16	08H	9CH	0.16	07H	D0H	0.16
600	07H	D0H	0.16	07H	9CH	0.16	06H	D0H	0.16
1200	06H	D0H	0.16	06H	9CH	0.16	05H	D0H	0.16
2400	05H	D0H	0.16	05H	9CH	0.16	04H	D0H	0.16
4800	04H	D0H	0.16	04H	9CH	0.16	03H	D0H	0.16
9600	03H	D0H	0.16	03H	9CH	0.16	02H	D0H	0.16
19200	02H	D0H	0.16	02H	9CH	0.16	01H	D0H	0.16
31250	02H	80H	0.00	01H	C0H	0.00	01H	80H	0.00
38400	01H	D0H	0.16	01H	9CH	0.16	00H	D0H	0.16
76800	00H	D0H	0.16	00H	9CH	0.16	00H	68H	0.16
153600	00H	68H	0.16	00H	4EH	0.16	00H	34H	0.16
312500	00H	33H	0.39	00H	26H	1.05	00H	1AH	-1.54
625000	00H	1AH	-1.54	00H	13H	1.05	00H	0DH	-1.54

**Remark**  $f_{XP}$ : Peripheral clock frequency (prescaler 1 input clock frequency)

In clock mode 1,  $f_{XP} = f_{XX}$

In clock mode 2,  $f_{XP} = f_{XMPLL}/2$  (14.64 to 16 MHz)

In clock mode 3,  $f_{XP} = f_{XMPLL}$  (29.28 to 32 MHz)

In clock mode 4,  $f_{XP} = f_{XMPLL}/2$  (20.88 to 24 MHz)

$f_{XX}$ : Main clock frequency

$f_{XMPLL}$ : PLL output clock frequency for peripheral clock

ERR: Baud rate error (%)

**(5) Allowable baud rate range during reception**

The baud rate error range at the destination that is allowable during reception is shown below.

**Caution** The baud rate error during reception must be set within the allowable error range using the following equation.

**Figure 15-14. Allowable Baud Rate Range During Reception**

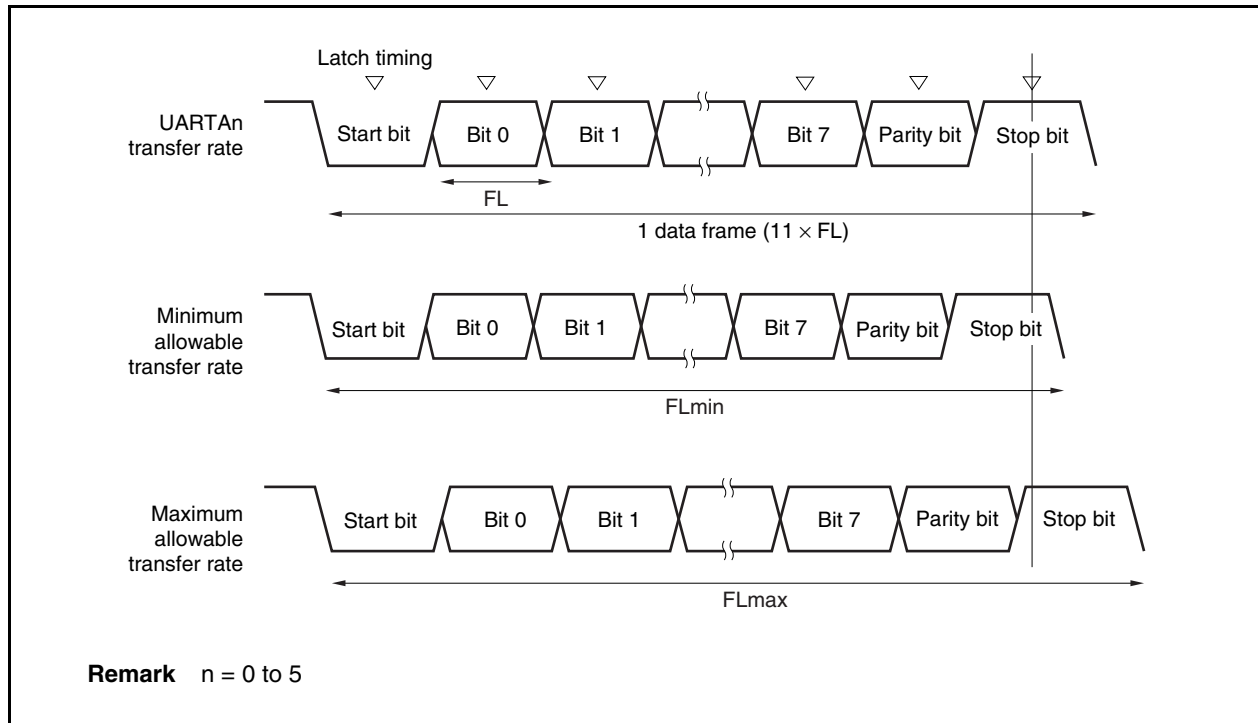

As shown in Figure 15-14, the receive data latch timing is determined by the counter set using the UAnCTL2 register following start bit detection. The transmit data can be normally received if up to the last data (stop bit) can be received in time for this latch timing.

When this is applied to 11-bit reception, the following is the theoretical result.

$$FL = (\text{Brate})^{-1}$$

Brate: UARTAn baud rate ( $n = 0$  to  $5$ )

k: Setting value of UAnCTL2.UAnBRS7 to UAnCTL2.UAnBRS0 bits ( $n = 0$  to  $5$ )

FL: 1-bit data length

Latch timing margin: 2 clocks

$$\text{Minimum allowable transfer rate: } FL_{\min} = 11 \times FL - \frac{k-2}{2k} \times FL = \frac{21k+2}{2k} FL$$

Therefore, the maximum baud rate that can be received by the destination is as follows.

$$BR_{max} = (FL_{min}/11)^{-1} = \frac{22k}{21k + 2} \text{ Brate}$$

Similarly, obtaining the following maximum allowable transfer rate yields the following.

$$\frac{10}{11} \times FL_{max} = 11 \times FL - \frac{k + 2}{2 \times k} \times FL = \frac{21k - 2}{2 \times k} FL$$

$$FL_{max} = \frac{21k - 2}{20 k} FL \times 11$$

Therefore, the minimum baud rate that can be received by the destination is as follows.

$$BR_{min} = (FL_{max}/11)^{-1} = \frac{20k}{21k - 2} \text{ Brate}$$

Obtaining the allowable baud rate error for UARTA and the destination from the above-described equations for obtaining the minimum and maximum baud rate values yields the following.

**Table 15-6. Maximum/Minimum Allowable Baud Rate Error**

Division Ratio (k)	Maximum Allowable Baud Rate Error	Minimum Allowable Baud Rate Error
4	+2.32%	-2.43%
8	+3.52%	-3.61%
20	+4.26%	-4.30%
50	+4.56%	-4.58%
100	+4.66%	-4.67%
255	+4.72%	-4.72%

- Remarks 1.** The reception accuracy depends on the bit count in 1 frame, the input clock frequency, and the division ratio (k). The higher the input clock frequency and the larger the division ratio (k), the higher the accuracy.
- 2.** k: Setting value of UAnCTL2.UAnBRS7 to UAnCTL2.UAnBRS0 bits (n = 0 to 5)

**(6) Baud rate during continuous transmission**

During continuous transmission, the transfer rate from the stop bit to the next start bit is usually 2 base clocks longer. However, timing initialization is performed via start bit detection by the receiving side, so this has no influence on the transfer result.

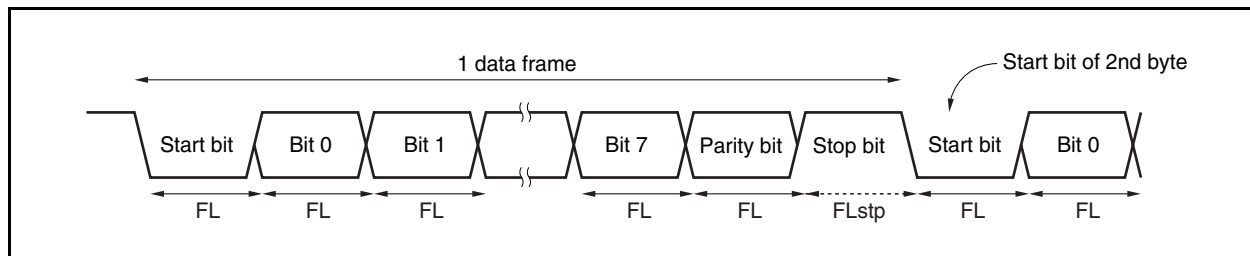
**Figure 15-15. Transfer Rate During Continuous Transfer**

Assuming 1 bit data length: FL; stop bit length: FLstp; and base clock frequency:  $f_{\text{UCLK}}$ , we obtain the following equation.

$$\text{FLstp} = \text{FL} + 2/f_{\text{UCLK}}$$

Therefore, the transfer rate during continuous transmission is as follows.

$$\text{Transfer rate} = 11 \times \text{FL} + (2/f_{\text{UCLK}})$$

## 15.8 Cautions

### (1) When clock supply to UARTAn is stopped

When the clock supply to UARTAn is stopped (for example, in IDLE1, IDLE2, or STOP mode), the operation stops with each register retaining the value it had immediately before the clock supply was stopped. The TXDAn pin output also holds and outputs the value it had immediately before the clock supply was stopped. However, the operation is not guaranteed after the clock supply is resumed. Therefore, after the clock supply is resumed, the circuits should be initialized by setting the UAnCTL0.UAnPWR, UAnCTL0.UAnRXEn, and UAnCTL0.UAnTXEn bits to 000.

### (2) Use of the RXDA1 and KR7 pins at the same time

The RXDA1 and KR7 pins must not be used at the same time. In the V850E/SK3-H, the RXDA1 and KR7 pins are assigned to two ports each, and cannot be used at the same time at different ports.

To use the RXDA1 pin, set the KRM.KRM7 bit of the KR7 pin to 0. To use the KR7 pin, set the UA1CTL0.UA1RXE bit to 0 (it is recommended to set the PFC91 bit to 1 and PFCE91 bit to 0 when using the KR7 pin at P91).

### (3) Error during DMA transfer

In UARTAn, the interrupt caused by a communication error does not occur. When performing the transfer of transmit data and receive data using DMA transfer, error processing cannot be performed even if errors (parity, overrun, framing) occur during transfer. Either read the UAnSTR register after DMA transfer has been completed to make sure that there are no errors, or read the UAnSTR register during communication to check for errors.

### (4) UARTAn startup sequence

Start up the UARTAn in the following sequence.

<1> Set the UAnCTL0.UAnPWR bit to 1.

<2> Set the ports.

<3> Set the UAnCTL0.UAnTXE bit to 1, UAnCTL0.UAnRXE bit to 1.

### (5) UARTAn stop sequence

Stop the UARTAn in the following sequence.

<1> Set the UAnCTL0.UAnTXE bit to 0, UAnCTL0.UAnRXE bit to 0.

<2> Set the ports and set the UAnCTL0.UAnPWR bit to 0 (it is not a problem if port setting is not changed).

### (6) Writing the same value to the UAnTX register in transmit mode

In transmit mode (UAnCTL0.UAnPWR bit = 1 and UAnCTL0.UAnTXE bit = 1), do not overwrite the same value to the UAnTX register by software because transmission starts by writing to this register. To transmit the same value continuously, overwrite the same value.

### (7) Continuous transmission

In continuous transmission, the communication rate from the stop bit to the next start bit is extended 2 base clocks more than usual. However, the reception side initializes the timing by detecting the start bit, so the reception result is not affected.

**(8) Switching DMA transfer start factor****(a) Switching DMA transfer start factor between INTUA1R and INTIIC2 signals**

Setting the DMA transfer start factor to other than the following combinations is prohibited.

**<1> When using UARTA1 and I<sup>2</sup>C02 simultaneously, and the INTUA1R signal is specified as the DMA transfer start factor (V850E/SK3-H only)**

When the DTFRn.IFCn5 to IFCn0 bits = 28H, set the DTFROB1 bit of the option byte 0000007AH (see **CHAPTER 33 OPTION BYTE FUNCTION**) to 1. This disables the DMA transfer start factor for the INTIIC2 signal. Therefore, a DMA transfer starts only when the INTUA1R signal is generated. Even if the INTIIC2 signal is generated, DMA transfer does not start.

**<2> When not using UARTA1 and using only I<sup>2</sup>C02, and the INTIIC2 signal is specified as the DMA transfer start factor**

When the DTFRn.IFCn5 to IFCn0 bits = 28H, set the DTFROB1 bit of the option byte 0000007AH to 0. A DMA transfer starts when the INTUA1R or INTIIC2 signal is generated.

**<3> When not using I<sup>2</sup>C02 and using only UARTA1, and the INTUA1R signal is specified as the DMA transfer start factor**

When the DTFRn.IFCn5 to IFCn0 bits = 28H, set the DTFROB1 bit of the option byte 0000007AH to 0. A DMA transfer starts when the INTUA1R or INTIIC2 signal is generated.

**Remark** For details, see **Table 22-1 DMA Transfer Start Factors**.

**(b) Switching DMA transfer start factor between INTUA2R and INTIIC0 signals**

Setting the DMA transfer start factor to other than the following combinations is prohibited.

**<1> When using UARTA2 and I<sup>2</sup>C00 simultaneously, and the INTUA2R signal is specified as the DMA transfer start factor (V850E/SK3-H only)**

When the DTFRn.IFCn5 to IFCn0 bits = 2AH, set the DTFROB1 bit of the option byte 0000007AH (see **CHAPTER 33 OPTION BYTE FUNCTION**) to 1. This disables the DMA transfer start factor for the INTIIC0 signal. Therefore, a DMA transfer starts only when the INTUA2R signal is generated. Even if the INTIIC0 signal is generated, DMA transfer does not start.

**<2> When not using UARTA2 and using only I<sup>2</sup>C00, and the INTIIC0 signal is specified as the DMA transfer start factor**

When the DTFRn.IFCn5 to IFCn0 bits = 2AH, set the DTFROB1 bit of the option byte 0000007AH to 0. A DMA transfer starts when the INTUA2R or INTIIC0 signal is generated.

**<3> When not using I<sup>2</sup>C00 and using only UARTA2, and the INTUA2R signal is specified as the DMA transfer start factor**

When the DTFRn.IFCn5 to IFCn0 bits = 2AH, set the DTFROB1 bit of the option byte 0000007AH to 0. A DMA transfer starts when the INTUA2R or INTIIC0 signal is generated.

**Remark** For details, see **Table 22-1. DMA Transfer Start Factors**.



## CHAPTER 16 ASYNCHRONOUS SERIAL INTERFACE B (UARTB)

### 16.1 Features

<R>

- Transfer rate: Maximum 1.5 Mbps (using a dedicated baud rate generator)
- Full-duplex communications
- Single mode and FIFO mode selectable
  - Single mode: 8-bit × 1-stage data register (UBnTX register or UBnRX register) is used for each of transmission and reception.
  - FIFO mode
    - Transmit FIFO: UBnTX register (8 bits × 16 stages).
    - Receive FIFO: UBnRXAP register (16 bits × 16 stages)
      - The error information of a received data is stored in the higher 8 bits of the UBnRXAP register.
- Two-pin configuration
  - TXDBn: Transmit data output pin
  - RXDBn: Receive data input pin
- Reception error detection function
  - Overflow error (FIFO mode only)
  - Parity error
  - Framing error
  - Overrun error (single mode only)
- Interrupt sources: 5 types
  - Reception error interrupt request signal (INTUBnTIRE)
  - Reception completion interrupt request signal (INTUBnTIR)
  - Transmission enable interrupt request signal (INTUBnTIT)
  - FIFO transmission completion interrupt request signal (INTUBnTIF) (FIFO mode only)
  - Reception timeout interrupt request signal (INTUBnTITO) (FIFO mode only)
- The character length of transmit/receive data is specified according to the UBnCTL0 register
- Character length: 7 or 8 bits
- Parity functions: Odd, even, 0, or none
- Transmission stop bits: 1 or 2 bits
- MSB first/LSB first selectable for transfer data
- On-chip dedicated baud rate generator

## 16.2 Configuration

The block diagram of the UARTBn is shown below.

**Figure 16-1. Block Diagram of UARTBn**

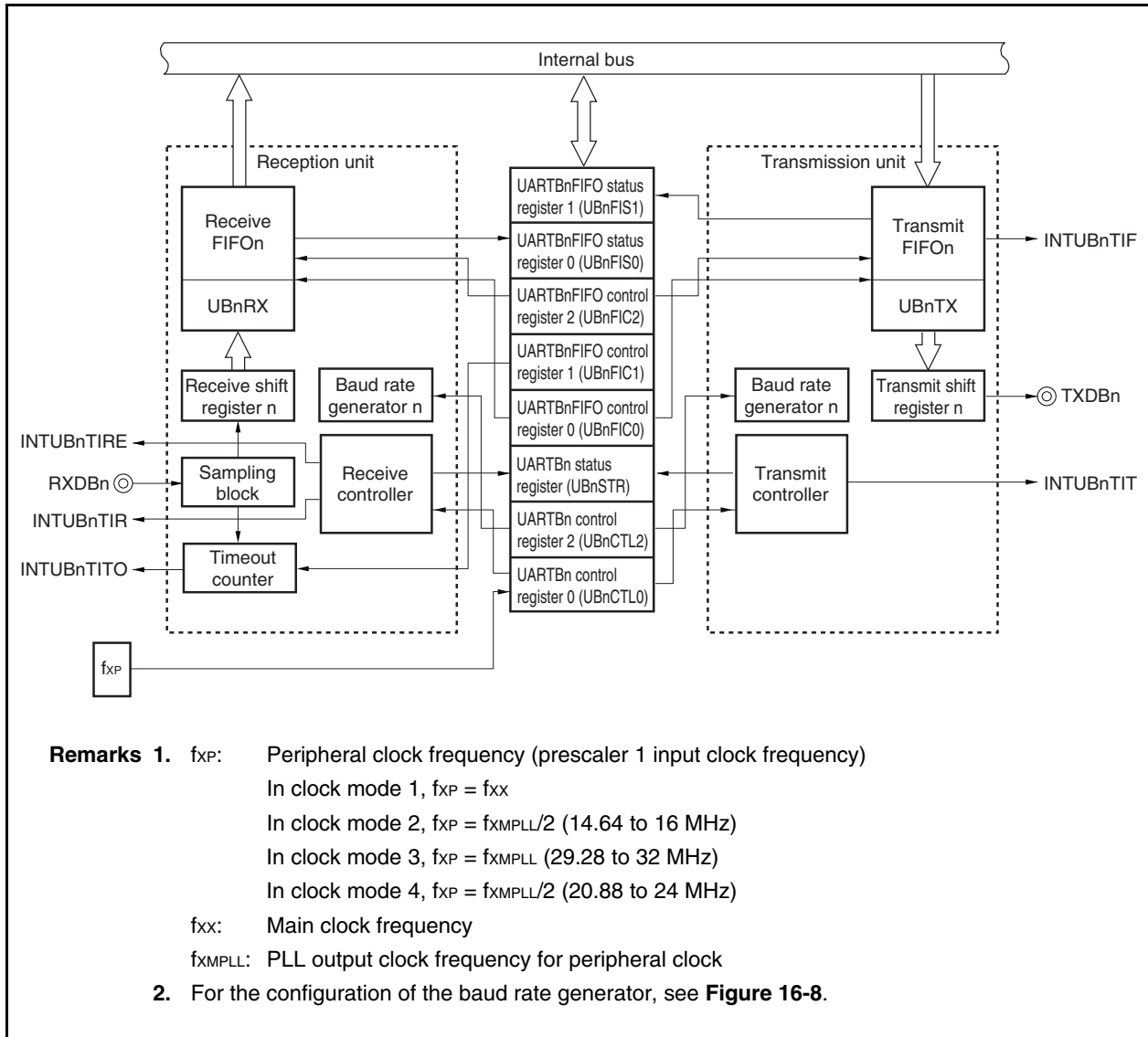

UARTBn consists of the following hardware units.

**Table 16-1. Configuration of UARTBn**

Item	Configuration
Registers	UARTBn control register 0 (UBnCTL0) UARTBn control register 2 (UBnCTL2) UARTBn status register (UBnSTR) UARTBn FIFO control register 0 (UBnFIC0) UARTBn FIFO control register 1 (UBnFIC1) UARTBn FIFO control register 2 (UBnFIC2) UARTBn FIFO status register 0 (UBnFIS0) UARTBn FIFO status register 1 (UBnFIS1) UARTBn receive shift register UARTBn receive data register AP (UBnRXAP) UARTBn receive data register (UBnRX) UARTBn transmit shift register UARTBn transmit data register (UBnTX)

**(1) UARTBn control register 0 (UBnCTL0)**

This register controls the transfer operation of UARTBn.

**(2) UARTBn status register (UBnSTR)**

This register indicates the transfer status during transmission and the contents of a reception error. The status flag of this register, which indicates the transfer status during transmission, indicates the data retention status of the transmit shift register n and the transmit data register n (the UBnTX register in the single mode or transmit FIFO n in the FIFO mode). Each reception error flag is set to 1 when a reception error occurs, and cleared to 0 when 0 is written to the UBnSTR register.

**(3) UARTBn control register 2 (UBnCTL2)**

This register is used to specify the division ratio by which to control the baud rate (serial transfer speed) of UARTBn.

**(4) UARTBn FIFO control register 0 (UBnFIC0)**

This register is used to select the operation mode of UARTBn, clear the transmit FIFO n/receive FIFO n that becomes valid in the FIFO mode, and specify the timing mode in which the transmission enable interrupt request signal (INTUBnTIT)/reception completion interrupt request signal (INTUBnTIR) occurs.

**(5) UARTBn FIFO control register 1 (UBnFIC1)**

This register is valid in the FIFO mode. It generates a reception timeout interrupt request signal (INTUBnTITO) if data is stored in the receive FIFO n when the next data does not come (start bit is not detected) even after the reception wait time of the next data has elapsed after the stop bit has been received.

**(6) UARTBn FIFO control register 2 (UBnFIC2)**

This register is valid in the FIFO mode. It is used to set the timing to generate the transmission completion interrupt request signal (INTUBnTIT)/reception completion interrupt request signal (INTUBnTIR), using the number of data transmitted or received as a trigger.

**(7) UARTBn FIFO status register 0 (UBnFIS0)**

This register is valid in the FIFO mode. The number of bytes of data stored in the receive FIFO can be read from this register.

**(8) UARTBn FIFO status register 1 (UBnFIS1)**

This register is valid in the FIFO mode. The number of empty bytes of the transmit FIFO can be read from this register.

**(9) UARTBn receive shift register**

This is a shift register that converts the serial data that was input to the RXDBn pin into parallel data. One byte of data is received, and if a stop bit is detected, the received data is transferred to the receive data register n.

This register cannot be directly manipulated.

**(10) UARTBn receive data register AP (UBnRXAP), UARTBn receive data register (UBnRX)**

The receive data register n holds receive data. In the single mode, the 8-bit  $\times$  1-stage UBnRX register is used. The 16-bit  $\times$  16-stage receive FIFO (UBnRXAP register) is used in the FIFO mode.

The receive data is stored in the lower 8 bits of the receive FIFO (UBnRXAP register) and the error information of the received data is stored in the higher 8 bits (bit 8 and bit 9). If a reception error (such as a parity error or a framing error) occurs in the FIFO mode, the error data can be identified by reading the UBnRXAP register in 16-bit (halfword) units (error information is appended as UBnPEF bit = 1 or UBnFEF bit = 1). When the lower 8 bits of the UBnRXAP register are read in 8-bit (byte) units, the higher 8 bits are discarded. Therefore, if no error has occurred, only the receive data of the UBnRXAP register can be read successively by being read in 8-bit (byte) units in the same way as the UBnRX register.

When 7-bit length data is received with the LSB first, the received data is transferred to bits 6 to 0 of the receive data register n from the LSB (bit 0), with the MSB (bit 7) always being 0. When data is received with the MSB first, the received data is transferred to bits 7 to 1 of the receive data register n from the MSB (bit 7), with the LSB (bit 0) always being 0. If an overrun error occurs, the receive data at that time is not transferred to the receive data register n.

While reception is enabled, the received data is transferred from the receive shift register n to the receive data register n, in synchronization with the shift-in processing of one frame.

A reception completion interrupt request signal (INTUBnTIR) is generated by transferring the data to the UBnRX register in the single mode, or transferring the number of receive data set as the trigger by the UBnFIC2.UBnRT3 to UBnFIC2.UBnRT0 bits to receive FIFO in the FIFO mode. If data is stored in receive FIFO when the next data does not come (start bit is not detected) after the next data reception wait time specified by the UBnFIC1.UBnTC4 to UBnFIC1.UBnTC0 bits has elapsed in the FIFO mode, a reception timeout interrupt request signal (INTUBnTITO) is generated.

**(11) UARTBn transmit shift register**

This is a shift register that converts the parallel data that was transferred from the transmit data register n into serial data.

When one byte of data is transferred from the transmit data register n, the transmit shift register data is output from the TXDBn pin.

This register cannot be directly manipulated.

**(12) UARTBn transmit data register (UBnTX)**

The transmit data register n is a buffer for transmit data. The 8-bit  $\times$  1-stage UBnTX register is used as this buffer in the single mode. In the FIFO mode, the 8-bit  $\times$  16-stage transmit FIFO n is used.

When 7-bit length data is transmitted with the LSB first, bits 6 to 0 of the transmit data register n are transmitted as the transmit data from the LSB (bit 0) with the MSB (bit 7) always being 0. When data is transmitted with the MSB first, bits 7 to 1 of the transmit data register n are transmitted as the transmit data from the MSB (bit 7) with the LSB (bit 0) always being 0.

In the single mode, transmission is started by writing transmit data to the UBnTX register while transmission is enabled (UBnCTL0.UBnTXE bit = 1). When writing the transmit data to the UBnTX register is enabled (when 1-byte data is transferred from the UBnTX register to the transmit shift register n), a transmission enable interrupt request signal (INTUBnTIT) is generated.

In the FIFO mode, transmission is started by writing at least the number of transmit data set as the trigger by the UBnFIC2.UBnTT3 to UBnFIC2.UBnTT0 bits and 16 bytes or less to transmit FIFO n and then enabling transmission (UBnTXE bit = 1). When the number of transmit data set as the trigger by the UBnFIC2.UBnTT3 to UBnFIC2.UBnTT0 bits have been transferred from transmit FIFO n to the transmit shift register n (transmit data of the number set as the trigger can be written), a transmission enable interrupt request signal (INTUBnTIT) is generated. In the FIFO mode, a FIFO transmission completion interrupt request signal (INTUBnTIF) is generated when there is no more data in transmit FIFO n and the transmit shift register n (when FIFO and the register become empty).

**(13) Timeout counter**

This counter is used to recognize that data exists (remains) in receive FIFO n when the number of received data does not reach the number set as the trigger by the UBnFIC2.UBnRT3 to UBnFIC2.UBnRT0 bits, and is valid only in the FIFO mode.

If data is stored in receive FIFO when the next data does not come (start bit is not detected) after the next data reception wait time specified by the UBnFIC1.UBnTC4 to UBnFIC1.UBnTC0 bits has elapsed after the stop bit has been received, a reception timeout interrupt request signal (INTUBnTITO) is generated.

**(14) Sampling block**

This block samples the RXDBn signal at the rising edge of  $f_{XP}$ . If the same sampling value is detected two times, output of the match detector changes, and the value is sampled as input data. Data of less than one clock width is judged as noise and is not transmitted to the internal circuitry.

**Remark**  $f_{XP}$ : Peripheral clock frequency (prescaler 1 input clock frequency)

In clock mode 1,  $f_{XP} = f_{XX}$

In clock mode 2,  $f_{XP} = f_{XMPLL}/2$  (14.64 to 16 MHz)

In clock mode 3,  $f_{XP} = f_{XMPLL}$  (29.28 to 32 MHz)

In clock mode 4,  $f_{XP} = f_{XMPLL}/2$  (20.88 to 24 MHz)

$f_{XX}$ : Main clock frequency

$f_{XMPLL}$ : PLL output clock frequency for peripheral clock

## 16.3 Control Registers

### (1) UARTBn control register 0 (UBnCTL0)

The UBnCTL0 register controls the transfer operations of UARTBn.

This register can be read or written in 8-bit or 1-bit units.

Reset sets this register to 10H.

- Cautions**
1. When using UARTBn, set the external pins related to the UARTBn function in the alternate-function mode, set UARTBn control register 2 (UBnCTL2). Then set the UBnPWR bit to 1 before setting the other bits.
  2. Be sure to input a high level to the RXDBn pin when setting the external pins related to the UARTBn function in the alternate-function mode. If a low level is input, it is judged that a falling edge is input after the UBnRXE bit has been set to 1, and reception may be started.

**Remark** When reception is disabled, the receive shift register n does not detect a start bit. No shift-in processing or transfer processing to the receive data register n is performed, and the contents of the receive data register are retained.

When reception is enabled, the receive shift operation starts, in synchronization with the detection of the start bit, and when the reception of one frame is completed, the contents of the receive shift register n are transferred to the receive data register n.

A reception completion interrupt request signal (INTUBnTIR) is also generated, in synchronization with the transfer to the receive data register n (in FIFO mode, transfer triggered by reaching set number of receive data).

If data is stored in receive FIFO n when the next data does not come (start bit is not detected) after the next data reception wait time specified by the UBnFIC1.UBnTC4 to UBnFIC1.UBnTC0 bits has elapsed in the FIFO mode, a reception timeout interrupt request signal (INTUBnTITO) is generated.

After reset: 10H R/W Address: UB0CTL0 FFFFFFFA80H, UB1CTL0 FFFFFFFAA0H

	<7>	<6>	<5>	<4>	3	2	1	0
UBnCTL0	UBnPWR	UBnTXE	UBnRXE	UBnDIR	UBnPS1	UBnPS0	UBnCL	UBnSL

(n = 0, 1)

UBnPWR	Operation clock control to UARTBn
0	Stops supply of clocks to UARTBn
1	Supplies clocks to UARTBn
<ul style="list-style-type: none"> <li>When the UBnPWR bit is cleared to 0, the UARTBn can be asynchronously reset.</li> <li>When the UBnPWR bit = 0, UARTBn is in a reset state. Therefore, to operate UARTBn, the UBnPWR bit must be set to 1.</li> <li>When the UBnPWR bit is changed from 1 to 0, all registers of UARTBn are initialized. When the UBnPWR bit is set to 1 again, the UARTBn registers must be set again.</li> <li>The TXDBn pin output is high level when the UBnPWR bit is cleared to 0.</li> </ul>	

UBnTXE	Transmission enable
0	Transmission is disabled
1	Transmission is enabled
<ul style="list-style-type: none"> <li>On startup, set the UBnPWR bit to 1 and then set the UBnTXE bit to 1. To stop transmission, clear the UBnTXE bit to 0 and then the UBnPWR bit to 0.</li> <li>When the transmission unit status is to be initialized, the transmission status may not be able to be initialized unless the UBnTXE bit is set to 1 again after an interval of two cycles of <math>f_{XP}</math> has elapsed since the UBnTXE bit was cleared to 0.</li> </ul>	

UBnRXE	Reception enable
0	Reception is disabled
1	Reception is enabled
<ul style="list-style-type: none"> <li>On startup, set the UBnPWR bit to 1 and then set the UBnRXE bit to 1. To stop reception, clear the UBnRXE bit to 0 and then the UBnPWR bit to 0.</li> <li>When the reception unit status is to be initialized, the reception status may not be able to be initialized unless the UBnRXE bit is set to 1 again after an interval of two cycles of <math>f_{XP}</math> has elapsed since the UBnRXE bit was cleared to 0.</li> </ul>	

**Remark**  $f_{XP}$ : Peripheral clock frequency (prescaler 1 input clock frequency)  
 In clock mode 1,  $f_{XP} = f_{XX}$   
 In clock mode 2,  $f_{XP} = f_{XMPLL}/2$  (14.64 to 16 MHz)  
 In clock mode 3,  $f_{XP} = f_{XMPLL}$  (29.28 to 32 MHz)  
 In clock mode 4,  $f_{XP} = f_{XMPLL}/2$  (20.88 to 24 MHz)  
 $f_{XX}$ : Main clock frequency  
 $f_{XMPLL}$ : PLL output clock frequency for peripheral clock

UBnDIR	Specification of transfer direction mode (MSB/LSB)
0	MSB transfer first
1	LSB transfer first

- Clear the UBnPWR bit or UBnTXE and UBnRXE bits to 0 before changing the setting of the UBnDIR bit.

UBnPS1	UBnPS0	Parity selection during transmission	Parity selection during reception
0	0	Do not output a parity bit	Receive with no parity
0	1	Output 0 parity	Receive as 0 parity
1	0	Output odd parity	Judge as odd parity
1	1	Output even parity	Judge as even parity

- Clear the UBnTXE and UBnRXE bits to 0 before overwriting the UBnPS1 and UBnPS0 bits.
- If “0 parity” is selected for reception, no parity judgment is made. Therefore, no error interrupt is generated because the UBnSTR.UBnPE bit is not set to 1.

UBnCL	Specification of data character length of 1-frame transmit/receive data
0	7 bits
1	8 bits

Clear the UBnTXE and UBnRXE bits to 0 before overwriting the UBnCL bit.

UBnSL	Specification of stop bit length of transmit data
0	1 bit
1	2 bits

- Clear the UBnTXE and UBnRXE bits to 0 before overwriting the UBnSL bit.
- Since reception always operates by using a single stop bit length, the UBnSL bit setting does not affect receive operations.

**Remark** For details of parity, see **16.6.6 Parity types and corresponding operation.**



**(2) UARTBn status register (UBnSTR)**

The UBnSTR register indicates the transfer status and reception error contents while UARTBn is transmitting data.

The status flag that indicates the transfer status during transmission indicates the data retention status of the transmit shift register n and transmit data register n (the UBnTX register in the single mode or transmit FIFO n in the FIFO mode). The status flag that indicates a reception error holds its status until it is cleared to 0.

This register can be read or written in 8-bit or 1-bit units.

Reset sets this register to 00H.

**Caution** When the UBnCTL0.UBnPWR bit or UBnCTL0.UBnRXE bit is set to 0, or when 0 is written to the UBnSTR register, the UBnSTR.UBnOVF, UBnSTR.UBnPE, UBnSTR.UBnFE, and UBnSTR.UBnOVE bits are cleared to 0.

After reset: 00H R/W Address: UB0STR FFFFFFFA84H, UB1STR FFFFFFFAA4H

	<7>	6	5	4	<3>	<2>	<1>	<0>
UBnSTR (n = 0, 1)	UBnTSF	0	0	0	UBnOVF	UBnPE	UBnFE	UBnOVE

UBnTSF	Transfer status flag
0	<ul style="list-style-type: none"> <li>In single mode (UBnFIC0.UBnMOD bit = 0) Data to be transferred to the transmit shift register n and UBnTX register does not exist (cleared (0) when UBnCTL0.UBnPWR bit = 0 or UBnCTL0.UBnTXE bit = 0).</li> <li>In FIFO mode (UBnFIC0.UBnMOD bit = 1) Data to be transferred to the transmit shift register n and transmit FIFO does not exist (cleared (0) when UBnCTL0.UBnPWR bit = 0 or UBnCTL0.UBnTXE bit = 0).</li> </ul>
1	<ul style="list-style-type: none"> <li>In single mode (UBnFIC0.UBnMOD bit = 0) Data to be transferred to the transmit shift register n or UBnTX register exists (transmission in progress).</li> <li>In FIFO mode (UBnFIC0.UBnMOD bit = 1) Data to be transferred to the transmit shift register n and transmit FIFO exists (transmission in progress).</li> </ul>

The value of the UBnTSF bit is reflected after two periods of  $f_{XP}$  have elapsed, after the transmit data is written to the UBnTX register. Therefore, exercise care when referencing the UBnTSF bit after transmit data has been written to the UBnTX register.

UBnOVF	Overflow flag
0	Overflow did not occur.
1	Overflow occurred (during reception).

- The UBnOVF bit is valid only in the FIFO mode (when UBnFIC0.UBnMOD bit = 1), and invalid in the single mode (when UBnFIC0.UBnMOD bit = 0).
- If an overflow occurs, the received data is not written to receive FIFO but discarded.

**Caution** Be sure to set bits 4 to 6 to “0”.

**Remark**  $f_{XP}$ : Peripheral clock frequency (prescaler 1 input clock frequency)  
 In clock mode 1,  $f_{XP} = f_{XX}$   
 In clock mode 2,  $f_{XP} = f_{XMPLL}/2$  (14.64 to 16 MHz)  
 In clock mode 3,  $f_{XP} = f_{XMPLL}$  (29.28 to 32 MHz)  
 In clock mode 4,  $f_{XP} = f_{XMPLL}/2$  (20.88 to 24 MHz)

$f_{XX}$ : Main clock frequency  
 $f_{XMPLL}$ : PLL output clock frequency for peripheral clock

UBnPE	Parity error flag
0	Parity error did not occur.
1	Parity error occurred (during reception).

- The UBnPE bit is valid only in the single mode (when UBnFIC0.UBnMOD bit = 0), and invalid in the FIFO mode (when UBnFIC0.UBnMOD bit = 1).
- The operation of the UBnPE bit differs according to the settings of the UBnCTL0.UBnPS1 and UBnCTL0.UBnPS0 bits.

UBnFE	Framing error flag
0	Framing error did not occur.
1	Framing error occurred (during reception).

- The UBnFE bit is valid only in the single mode (when UBnFIC0.UBnMOD bit = 0), and invalid in the FIFO mode (when UBnFIC0.UBnMOD bit = 1).
- Only the first bit of the stop bits of the receive data is checked, regardless of the stop bit length.

UBnOVE	Overrun error flag
0	Overrun error did not occur.
1	Overrun error occurred (during reception).

- The UBnOVE bit is valid only in the single mode (when UBnFIC0.UBnMOD bit = 0), and invalid in the FIFO mode (when UBnFIC0.UBnMOD bit = 1).
- When an overrun error occurs, the next receive data value is not written to the UBnRX register and the data is discarded.

**(3) UARTBn control register 2 (UBnCTL2)**

The UBnCTL2 register is used to specify the division ratio by which to control the baud rate (serial transfer speed) of UARTBn.

This register can be read or written in 16-bit units.

Reset sets this register to FFFFH.

**Caution** When rewriting the UBnBRS15 to UBnBRS0 bits of this register, set the UBnCTL0.UBnTXE and UBnCTL0.UBnRXE bits to 0 or clear the UBnCTL0.UBnPWR bit to 0.

After reset: FFFFH		R/W		Address: UB0CTL2 FFFFFA82H, UB1CTL2 FFFFFAA2H														
		15	14	13	12	11	10	9	8	7	6	5	4	3	2	1	0	
UBnCTL2 (n = 0, 1)	UBn	UBn	UBn	UBn	UBn	UBn	UBn	UBn	UBn	UBn	UBn	UBn	UBn	UBn	UBn	UBn	UBn	
	BRS	BRS	BRS	BRS	BRS	BRS	BRS	BRS	BRS	BRS	BRS	BRS	BRS	BRS	BRS	BRS	BRS	
	15	14	13	12	11	10	9	8	7	6	5	4	3	2	1	0		

**Remark** For the UBnBRS15 to UBnBRS0 bits, see **Table 16-2 Division Value of 16-bit Counter**.

**Table 16-2. Division Value of 16-bit Counter**

UBn BRS 15	UBn BRS 14	UBn BRS 13	UBn BRS 12	UBn BRS 11	UBn BRS 10	UBn BRS 9	UBn BRS 8	UBn BRS 7	UBn BRS 6	UBn BRS 5	UBn BRS 4	UBn BRS 3	UBn BRS 2	UBn BRS 1	UBn BRS 0	k	Output Clock Selected
0	0	0	0	0	0	0	0	0	0	0	0	0	0	x	x	4	$f_{XP}/k$
0	0	0	0	0	0	0	0	0	0	0	0	0	1	0	0	4	$f_{XP}/k$
0	0	0	0	0	0	0	0	0	0	0	0	0	1	0	1	5	$f_{XP}/k$
0	0	0	0	0	0	0	0	0	0	0	0	0	1	1	0	6	$f_{XP}/k$
•	•	•	•	•	•	•	•	•	•	•	•	•	•	•	•	•	•
•	•	•	•	•	•	•	•	•	•	•	•	•	•	•	•	•	•
•	•	•	•	•	•	•	•	•	•	•	•	•	•	•	•	•	•
1	1	1	1	1	1	1	1	1	1	1	1	1	1	0	0	65532	$f_{XP}/k$
1	1	1	1	1	1	1	1	1	1	1	1	1	1	0	1	65533	$f_{XP}/k$
1	1	1	1	1	1	1	1	1	1	1	1	1	1	1	0	65534	$f_{XP}/k$
1	1	1	1	1	1	1	1	1	1	1	1	1	1	1	1	65535	$f_{XP}/k$

**Remarks 1.**  $f_{XP}$ : Peripheral clock frequency (prescaler 1 input clock frequency)

In clock mode 1,  $f_{XP} = f_{XX}$

In clock mode 2,  $f_{XP} = f_{XMPLL}/2$  (14.64 to 16 MHz)

In clock mode 3,  $f_{XP} = f_{XMPLL}$  (29.28 to 32 MHz)

In clock mode 4,  $f_{XP} = f_{XMPLL}/2$  (20.88 to 24 MHz)

$f_{XX}$ : Main clock frequency

$f_{XMPLL}$ : PLL output clock frequency for peripheral clock

**2.** k: Value set by the UBnCTL2.UBnBRS15 to UBnCTL2.UBnBRS0 bits (k = 4, 5, 6, ..., 65535)

**3.** x: Don't care

**(4) UARTBn transmit data register (UBnTX)**

The UBnTX register is used to set transmit data. It functions as the 8-bit × 1-stage UBnTX register, in the single mode (UBnFIC0.UBnMOD bit = 0), and as the 8-bit × 16-stage transmit FIFO in the FIFO mode (UBnFIC0.UBnMOD bit = 1).

In the single mode, transmission is started by writing transmit data to the UBnTX register when transmission is enabled (UBnCTL0.UBnTXE bit = 1). When data can be written to the UBnTX register (when 1 byte of data is transferred from the UBnTX register to the transmit shift register n), a transmission enable interrupt request signal (INTUBnTIT) is generated.

In the FIFO mode, transmission is started by enabling transmission (UBnTXE bit = 1) after writing at least the number of transmit data set as the trigger by the UBnFIC2.UBnTT3 to UBnFIC2.UBnTT0 bits and 16 bytes or less to transmit FIFO. When the number of transmit data set as the trigger by the UBnFIC2.UBnTT3 to UBnFIC2.UBnTT0 bits have been transferred from transmit FIFO to the transmit shift register n (transmit data of the number set as the trigger can be written to transmit FIFO), a transmission enable interrupt request signal (INTUBnTIT) is generated. In the FIFO mode, a FIFO transmission completion interrupt request signal (INTUBnTIF) is generated when there is no more data in transmit FIFO and the transmit shift register n (when the FIFO and register become empty).

For the generation timing of the interrupt, see **16.4 Interrupt Request Signals**.

When 7-bit length data is transmitted with the LSB first, bits 6 to 0 of the transmit data register n are transmitted as the transmit data from the LSB (bit 0) with the MSB (bit 7) always being 0. When data is transmitted with the MSB first, bits 7 to 1 of the transmit data register n are transmitted as the transmit data from the MSB (bit 7) with the LSB (bit 0) always being 0.

This register is write-only in 8-bit units. Data is written to the transmit data register n.

Reset sets this register to FFH.

**Caution** Accessing the UBnTX register is prohibited in the following statuses. For details, refer to **3.4.9 (2) Accessing specific on-chip peripheral I/O registers**.

- When the CPU operates with the subclock and the main clock oscillation is stopped
- When the CPU operates with the internal oscillation clock

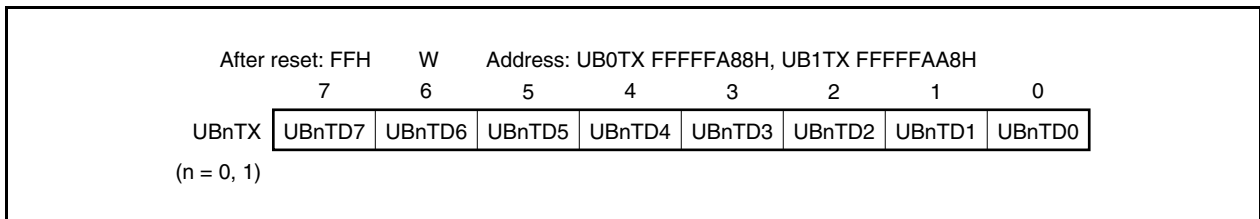

**(5) UARTBn receive data register AP (UBnRXAP), UARTBn receive data register (UBnRX)**

These registers store parallel data converted by the receive shift register n. They function as the 8-bit × 1-stage UBnRX register, in the single mode (UBnFIC0.UBnMOD bit = 0), and as the 16-bit × 16-stage receive FIFO (UBnRXAP register) in the FIFO mode (UBnFIC0.UBnMOD bit = 1).

The receive data is stored in the lower 8 bits of the receive FIFO (UBnRXAP register) and the error information of the received data is stored in the higher 8 bits (bit 8 and bit 9). If a reception error (such as a parity error or a framing error) occurs in the FIFO mode, the UBnRXAP register is read in 16-bit (halfword) units. In this way, the flag of the data stored in receive FIFO can be checked (error information is appended as UBnPEF bit = 1 or UBnFEF bit = 1), so that the error data can be recognized (when the lower 8 bits of the UBnRXAP register are read in 8-bit (byte) units, the higher 8 bits are discarded. Therefore, if no error has occurred, the receive data of the UBnRXAP register can be read successively by being read in 8-bit (byte) units in the same way as the UBnRX register).

If reception is enabled (UBnCTL0.UBnRXE bit = 1), the receive data is transferred from the receive shift register n to the receive data register n, in synchronization with the completion of the shift-in processing of one frame.

By transferring the receive data to the UBnRX register in the single mode or by transferring the number of receive data set as the trigger by the UBnFIC2.UBnRT3 to UBnFIC2.UBnRT0 bits to the receive FIFO in the FIFO mode, a reception completion interrupt request signal (INTUBnTIR) is generated. If data is stored in receive FIFO when the next data does not come (start bit is not detected) even after the next data reception wait time specified by the UBnFIC1.UBnTC4 to UBnFIC1.UBnTC0 bits has elapsed in the FIFO mode, a reception timeout interrupt request signal (INTUBnTITO) is generated.

For information about the timing for generating these interrupt requests, see **16.4 Interrupt Request Signals**.

If data is received with the LSB first when the data length is specified as 7 bits, the received data is transferred to bits 6 to 0 of the receive data register n from the LSB (bit 0), with the MSB (bit 7) always being 0. If data is received with the MSB first, it is transferred to bits 7 to 1 of the receive data register n from the MSB (bit 7) with the LSB (bit 0) always being 0. However, if an overrun error occurs, the receive data at that time is not transferred to the receive data register n.

The UBnRXAP register is read-only in 16-bit units. However, the lower 8 bits of the UBnRXAP register are read-only in 8-bit units.

The UBnRX register is read-only in 8-bit units.

In addition to reset input, the value of these registers can be set to FFH in the single mode or to 00FFH in the FIFO mode, by clearing the UBnCTL0.UBnPWR bit to 0.

**Cautions 1. Accessing the UBnRXAP and UBnRX registers is prohibited in the following statuses. For details, refer to 3.4.9 (2) Accessing specific on-chip peripheral I/O registers.**

- When the CPU operates with the subclock and the main clock oscillation is stopped
  - When the CPU operates with the internal oscillation clock
2. The UBnPEF and UBnFEF bits cannot be read because these registers serve as 8-bit registers in the single mode.
  3. When no reception error has occurred in the FIFO mode, the receive data of the UBnRXAP register can be read successively by reading the lower 8 bits of the UBnRXAP register in 8-bit (byte) units. An 8-bit access to the higher 8 bits is prohibited. If they are accessed, the operation is not guaranteed.

**Cautions 4. Do not perform the following operations when debugging a system that uses the single mode.**

- **Setting a break for an instruction immediately after the UBnRX register is read**
- **Setting a break before DMA transfer with the UBnRX register specified as the transfer source is completed**
- **Setting a break before completion of reception of the next data after reception of data and reading the UBnRX register, and checking the UBnRX register in the I/O register window of the debugger**

**If any of these operations is performed, an overrun error may occur during the subsequent reception.**

After reset: 00FFH R Address: UB0RXAP FFFFFFFA86H, UB1RXAP FFFFFFFAA6H

	15	14	13	12	11	10	9	8	7	6	5	4	3	2	1	0
UBnRXAP (n = 0, 1)	0	0	0	0	0	0	UBn PEF	UBn FEF	UBn RD7	UBn RD6	UBn RD5	UBn RD4	UBn RD3	UBn RD2	UBn RD1	UBn RD0

After reset: FFH R Address: UB0RX FFFFFFFA86H, UB1RX FFFFFFFAA6H

	7	6	5	4	3	2	1	0
UBnRX (n = 0, 1)	UBnRD7	UBnRD6	UBnRD5	UBnRD4	UBnRD3	UBnRD2	UBnRD1	UBnRD0

UBnPEF	Parity error flag
0	No parity error
1	Parity error occurs (during reception).

- The UBnPEF bit is valid only in the FIFO mode (UBnFIC0.UBnMOD bit = 1), and is invalid in the single mode (UBnFIC0.UBnMOD bit = 0).
- The operation of the UBnPEF bit differs depending on the set values of the UBnCTL0.UBnPS1 and UBnCTL0.UBnPS0 bits.

UBnFEF	Framing error flag
0	No framing error
1	Framing error occurs (during reception).

- The UBnFEF bit is valid only in the FIFO mode (UBnFIC0.UBnMOD bit = 1), and is invalid in the single mode (UBnFIC0.UBnMOD bit = 0).
- Only the first bit of the stop bits of the receive data is checked, regardless of the stop bit length.

UBnRD7 to UBnRD0	Stores receive data.
---------------------	----------------------

**(6) UARTBn FIFO control register 0 (UBnFIC0)**

The UBnFIC0 register is used to select the operation mode of UARTBn and the functions that become valid in the FIFO mode (UBnMOD bit = 1). In the FIFO mode, it clears transmit FIFO/receive FIFO and specifies the timing mode in which the transmission enable interrupt request signal (INTUBnTIT)/reception completion interrupt request signal (INTUBnTIR) is generated.

This register can be read or written in 8-bit or 1-bit units.

Reset sets this register to 00H.



After reset: 00H    R/W    Address: UB0FIC0 FFFFFFFA8AH, UB1FIC0 FFFFFFFAAAH

	<7>	6	5	4	<3>	<2>	1	0
UBnFIC0 (n = 0, 1)	UBnMOD	0	0	0	UBnTFC	UBnRFC	UBnITM	UBnIRM

UBnMOD	Specification of UARTBn operation mode
0	Single mode
1	FIFO mode

UBnTFC	Transmit FIFO clear trigger bit
0	Normal status
1	Clear (This bit automatically returns to 0 after transmit FIFO is cleared.)

- The UBnTFC bit is valid only in the FIFO mode (UBnMOD bit = 1), and is invalid in the single mode (UBnMOD bit = 0).
- When 1 is written to the UBnTFC bit, the pointer to transmit FIFO is cleared to 0. In the pending mode (UBnITM bit = 0), the interrupt request signal (INTUBnTIT) held pending is cleared<sup>Note</sup>. However, bit 7 (UBnTITIF) of the interrupt control register (UBnTITIC) is not cleared to 0. Clear this bit to 0 as necessary.  
When 0 is written to the UBnTFC bit, the status is retained. No operation, such as clearing or setting, is executed.
- When writing 1 to the UBnTFC bit, be sure to clear the UBnCTL0.UBnTXE bit to 0 (disabling transmission). If 1 is written to the UBnTFC bit when the UBnTXE bit is 1 (transmission enabled), the operation is not guaranteed.

**Note** After transmit FIFO is cleared (UBnTFC bit = 1), accessing the registers related to UARTBn is prohibited for the duration of four cycles of  $f_{XP}$  or until clearing the UBnTFC bit (automatic recovery) is confirmed by reading the UBnFIC0 register. If these registers are accessed, the operation is not guaranteed.

**Cautions 1.** Be sure to select the single mode when writing a transmit data or reading a received data by using the DMA control. In FIFO mode, the use of the DMA control is prohibited.

**2.** Be sure to set bits 4 to 6 to “0”.

**Remark**  $f_{XP}$ : Peripheral clock frequency (prescaler 1 input clock frequency)  
 In clock mode 1,  $f_{XP} = f_{XX}$   
 In clock mode 2,  $f_{XP} = f_{XMPLL}/2$  (14.64 to 16 MHz)  
 In clock mode 3,  $f_{XP} = f_{XMPLL}$  (29.28 to 32 MHz)  
 In clock mode 4,  $f_{XP} = f_{XMPLL}/2$  (20.88 to 24 MHz)  
 $f_{XX}$ : Main clock frequency  
 $f_{XMPLL}$ : PLL output clock frequency for peripheral clock

UBnRFC	Receive FIFO <sub>n</sub> (UBnRXAP) clear trigger bit
0	Normal status
1	Clear (This bit automatically returns to 0 after receive FIFO <sub>n</sub> is cleared.)

- The UBnRFC bit is valid only in the FIFO mode (UBnMOD bit = 1), and is invalid in the single mode (UBnMOD bit = 0).
- When 1 is written to the UBnRFC bit, the pointer to receive FIFO<sub>n</sub> is cleared to 0. In the pending mode (UBnIRM bit = 0), the interrupt request signal (INTUBnTIR) held pending is cleared<sup>Note</sup>. However, bit 7 (UBnTIRIF) of the interrupt control register (UBnTIRIC) is not cleared to 0. Clear this bit to 0 as necessary.  
When 0 is written to the UBnRFC bit, the status is retained. No operation, such as clearing or setting, is executed.
- When writing 1 to the UBnRFC bit, be sure to clear the UBnCTL0.UBnRXE bit to 0 (disabling reception). If 1 is written to the UBnRFC bit when the UBnRXE bit is 1 (reception enabled), the operation is not guaranteed.

UBnITM	Specification of INTUBnTIT interrupt generation timing in FIFO mode
0	Pending mode
1	Pointer mode

In the FIFO mode, the INTUBnTIT signal is generated as soon as transmit data of the number set as the trigger by the UBnFIC2.UBnTT3 to UBnFIC2.UBnTT0 bits have been transferred from transmit FIFO<sub>n</sub> to the transmit shift register n. After the INTUBnTIT signal request has been generated, specify the timing of actually generating the INTUBnTIT signal as the pending mode or pointer mode. For details, see **16.5 (2) Pending mode/pointer mode**.

**Note** After receive FIFO<sub>n</sub> (UBnRXAP) is cleared (UBnRFC bit = 1), accessing the registers related to UARTB<sub>n</sub> is prohibited for the duration of four cycles of  $f_{XP}$  or until clearing the UBnRFC bit (automatic recovery) is confirmed by reading the UBnFIC0 register. If these registers are accessed, the operation is not guaranteed.

**Remark**  $f_{XP}$ : Peripheral clock frequency (prescaler 1 input clock frequency)  
 In clock mode 1,  $f_{XP} = f_{XX}$   
 In clock mode 2,  $f_{XP} = f_{XMPLL}/2$  (14.64 to 16 MHz)  
 In clock mode 3,  $f_{XP} = f_{XMPLL}$  (29.28 to 32 MHz)  
 In clock mode 4,  $f_{XP} = f_{XMPLL}/2$  (20.88 to 24 MHz)  
 $f_{XX}$ : Main clock frequency  
 $f_{XMPLL}$ : PLL output clock frequency for peripheral clock

UBnIRM	Specification of INTUBnTIR interrupt generation timing in FIFO mode
0	Pending mode
1	Pointer mode

In the FIFO mode, the INTUBnTIR signal is generated as soon as receive data of the number set as the trigger by the UBnFIC2.UBnRT3 to UBnFIC2.UBnRT0 bits have been transferred from the receive shift register n to receive FIFO. After the INTUBnTIR signal request has been generated, specify the timing of actually generating the INTUBnTIR signal as the pending mode or pointer mode. For details, see **16.5 (2) Pending mode/pointer mode**.

**(7) UARTBn FIFO control register 1 (UBnFIC1)**

The UBnFIC1 register is valid in the FIFO mode (UBnFIC0.UBnMOD bit = 1). It generates a reception timeout interrupt request signal (INTUBnTITO) if data is stored in receive FIFO when the next data does not come (start bit is not detected) after the lapse of the time set by the UBnTC4 to UBnTC0 bits (next data reception wait time), after the stop bit has been received.

This register can be read or written in 8-bit or 1-bit units.

Reset sets this register to 00H.

After reset: 00H    R/W    Address: UB0FIC1 FFFFA8BH, UB1FIC1 FFFFAABH

<7>	6	5	4	3	2	1	0	
UBnFIC1	UBnTCE	0	0	UBnTC4	UBnTC3	UBnTC2	UBnTC1	UBnTC0

(n = 0, 1)

UBnTCE	Specification of timeout counter function disable/enable
0	Disable use of timeout counter function.
1	Enable use of timeout counter function.

UBnTC4	UBnTC3	UBnTC2	UBnTC1	UBnTC0	Next data reception wait time
0	0	0	0	0	32 bytes (32 × 8/ baud rate)
0	0	0	0	1	31 bytes (31 × 8/ baud rate)
0	0	0	1	0	30 bytes (30 × 8/ baud rate)
0	0	0	1	1	29 bytes (29 × 8/ baud rate)
•	•	•	•	•	•
•	•	•	•	•	•
•	•	•	•	•	•
1	1	1	0	0	4 bytes (4 × 8/ baud rate)
1	1	1	0	1	3 bytes (3 × 8/ baud rate)
1	1	1	1	0	2 bytes (2 × 8/ baud rate)
1	1	1	1	1	1 byte (1 × 8/ baud rate)

When counting up of the reception wait time, set by the UBnTC4 to UBnTC0 bits, is complete, the count value of the timeout counter is cleared to 0, regardless of the status of the data stored in receive FIFO. When the next start bit is later detected, counting is started again from the stop bit of that data.

**Caution** Be sure to set bits 5 and 6 to “0”.

**(8) UARTBn FIFO control register 2 (UBnFIC2)**

The UBnFIC2 register is valid in the FIFO mode (UBnFIC0.UBnMOD bit = 1). It sets the timing of generating an interrupt, using the number of transmit/receive data as a trigger. When data is transmitted, the number of data transferred from transmit FIFO<sub>n</sub> is specified as the condition of generating the interrupt. When data is received, the number of data stored in receive FIFO<sub>n</sub> is specified as the interrupt generation condition.

This register can be read or written in 16-bit units.

When the higher 8 bits of the UBnFIC2 register can be used as the UBnFIC2H register and the lower 8 bits, as the UBnFIC2L register, these registers can be read or written in 8-bit units.

Reset sets the UBnFIC2 register to 0000H and the UBnFIC2H and UBnFIC2L registers to 00H.

**Caution** Be sure to set the UBnCTL0.UBnTXE bit (to disable transmission) and UBnCTL0.UBnRXE bit (to disable reception) to 0 before writing data to the UBnFIC2 register. If data is written to the UBnFIC2 register with the UBnTXE or UBnRXE bit set to 1, the operation is not guaranteed.

(1/2)

After reset: 0000H    R/W    Address: UB0FIC2 FFFFA8CH, UB1FIC2 FFFFAACH																
	15	14	13	12	11	10	9	8	7	6	5	4	3	2	1	0
UBnFIC2 (n = 0, 1)	0	0	0	0	UBn TT3	UBn TT2	UBn TT1	UBn TT0	0	0	0	0	UBn RT3	UBn RT2	UBn RT1	UBn RT0

UBnTT3	UBnTT2	UBnTT1	UBnTT0	Number of data of transmit FIFO <sub>n</sub> set as trigger	Pointer mode	Pending mode
0	0	0	0	1 byte	Settable	Settable
0	0	0	1	2 bytes	Setting prohibited	
0	0	1	0	3 bytes		
0	0	1	1	4 bytes		
0	1	0	0	5 bytes		
0	1	0	1	6 bytes		
0	1	1	0	7 bytes		
0	1	1	1	8 bytes		
1	0	0	0	9 bytes		
1	0	0	1	10 bytes		
1	0	1	0	11 bytes		
1	0	1	1	12 bytes		
1	1	0	0	13 bytes		
1	1	0	1	14 bytes		
1	1	1	0	15 bytes		
1	1	1	1	16 bytes		

- Set the number of transmit FIFO<sub>n</sub> transmit data to be the trigger.
- Each time data of the specified number has shifted out from transmit FIFO<sub>n</sub> to the transmit shift register n, the INTUBnTIT signal is generated.  
In the pending mode (UBnFIC0.UBnITM bit = 0), the INTUBnTIT signal is generated under the conditions of the pending mode.
- In the pointer mode (UBnFIC0.UBnITM bit = 1), the number of transmit data set as the trigger can be only 1 byte (UBnTT3 to UBnTT0 bits = 0000), and other settings are prohibited. If a setting of other than 1 byte is made, the operation is not guaranteed.

**Caution** Be sure to set bits 4 to 7 and 12 to 15 to “0”.

UBnRT3	UBnRT2	UBnRT1	UBnRT0	Number of data of transmit FIFO set as trigger	Pointer mode	Pending mode
0	0	0	0	1 byte	Settable	Settable
0	0	0	1	2 bytes	Setting prohibited	
0	0	1	0	3 bytes		
0	0	1	1	4 bytes		
0	1	0	0	5 bytes		
0	1	0	1	6 bytes		
0	1	1	0	7 bytes		
0	1	1	1	8 bytes		
1	0	0	0	9 bytes		
1	0	0	1	10 bytes		
1	0	1	0	11 bytes		
1	0	1	1	12 bytes		
1	1	0	0	13 bytes		
1	1	0	1	14 bytes		
1	1	1	0	15 bytes		
1	1	1	1	16 bytes		

- Set the number of receive FIFO receive data to be the trigger.
- Each time data of the specified number has been stored from the receive shift register n to receive FIFO, the INTUBnTIR interrupt is generated.  
In the pending mode (UBnFIC0.UBnIRM bit = 0), the INTUBnTIR signal is generated under the conditions of the pending mode.
- In the pointer mode (UBnFIC0.UBnIRM bit = 1), the number of receive data set as the trigger can be only 1 byte (UBnRT3 to UBnRT0 bits = 0000), and other settings are prohibited. If a setting of other than 1 byte is made, the operation is not guaranteed.

**(9) UARTBn FIFO status register 0 (UBnFIS0)**

The UBnFIS0 register is valid in the FIFO mode (UBnFIC0.UBnMOD bit = 1). It is used to read the number of bytes of the data stored in receive FIFO.

This register is read-only in 8-bit units.

Reset sets this register to 00H.

**Caution** Accessing the UBnFIS0 register is prohibited in the following statuses. For details, refer to 3.4.9 (2) Accessing specific on-chip peripheral I/O registers.

- When the CPU operates with the subclock and the main clock oscillation is stopped
- When the CPU operates with the internal oscillation clock

After reset: 00H	R	Address: UB0FIS0 FFFFA8EH, UB1FIS0 FFFFAAEH						
UBnFIS0	7	6	5	4	3	2	1	0
(n = 0, 1)	0	0	0	UBnRB4	UBnRB3	UBnRB2	UBnRB1	UBnRB0
	UBnRB4	UBnRB3	UBnRB2	UBnRB1	UBnRB0	Receive FIFO pointer		
	0	0	0	0	0	0 bytes		
	0	0	0	0	1	1 byte		
	0	0	0	1	0	2 bytes		
	0	0	0	1	1	3 bytes		
	0	0	1	0	0	4 bytes		
	0	0	1	0	1	5 bytes		
	0	0	1	1	0	6 bytes		
	0	0	1	1	1	7 bytes		
	0	1	0	0	0	8 bytes		
	0	1	0	0	1	9 bytes		
	0	1	0	1	0	10 bytes		
	0	1	0	1	1	11 bytes		
	0	1	1	0	0	12 bytes		
	0	1	1	0	1	13 bytes		
	0	1	1	1	0	14 bytes		
	0	1	1	1	1	15 bytes		
	1	0	0	0	0	16 bytes		
	Other than above					Invalid		
Indicates the number of bytes (readable bytes) of the data stored in receive FIFO as a receive FIFO pointer.								

**(10) UARTBn FIFO status register 1 (UBnFIS1)**

The UBnFIS1 register is valid in the FIFO mode (UBnFIC0.UBnMOD bit = 1). This register can be used to read the number of empty bytes of transmit FIFO.

This register is read-only in 8-bit units.

Reset sets this register to 10H.

**Cautions** 1. **Accessing the UBnFIS1 register is prohibited in the following statuses. For details, refer to 3.4.9 (2) Accessing specific on-chip peripheral I/O registers.**

- **When the CPU operates with the subclock and the main clock oscillation is stopped**
  - **When the CPU operates with the internal oscillation clock**
2. **The values of the UBnTB4 to UBnTB0 bits are reflected after transmit data has been written to the UBnTX register and then time of two cycles of  $f_{XP}$  has passed. Therefore, care must be exercised when referencing the UBnFIS1 register after transmit data has been written to the UBnTX register.**

**Remark**  $f_{XP}$ : Peripheral clock frequency (prescaler 1 input clock frequency)

In clock mode 1,  $f_{XP} = f_{XX}$

In clock mode 2,  $f_{XP} = f_{XMPLL}/2$  (14.64 to 16 MHz)

In clock mode 3,  $f_{XP} = f_{XMPLL}$  (29.28 to 32 MHz)

In clock mode 4,  $f_{XP} = f_{XMPLL}/2$  (20.88 to 24 MHz)

$f_{XX}$ : Main clock frequency

$f_{XMPLL}$ : PLL output clock frequency for peripheral clock



After reset: 10H R Address: UB0FIS1 FFFFFFFA8FH, UB1FIS1 FFFFFFFAAFH

	7	6	5	4	3	2	1	0
UBnFIS1 (n = 0, 1)	0	0	0	UBnTB4	UBnTB3	UBnTB2	UBnTB1	UBnTB0

UBnTB4	UBnTB3	UBnTB2	UBnTB1	UBnTB0	Transmit FIFO n pointer
0	0	0	0	0	0 bytes
0	0	0	0	1	1 byte
0	0	0	1	0	2 bytes
0	0	0	1	1	3 bytes
0	0	1	0	0	4 bytes
0	0	1	0	1	5 bytes
0	0	1	1	0	6 bytes
0	0	1	1	1	7 bytes
0	1	0	0	0	8 bytes
0	1	0	0	1	9 bytes
0	1	0	1	0	10 bytes
0	1	0	1	1	11 bytes
0	1	1	0	0	12 bytes
0	1	1	0	1	13 bytes
0	1	1	1	0	14 bytes
0	1	1	1	1	15 bytes
1	0	0	0	0	16 bytes
Setting prohibited					Invalid

Indicates the number of empty bytes of transmit FIFO n (bytes that can be written) as a transmit FIFO n pointer.

## 16.4 Interrupt Request Signals

The following five types of interrupt requests are generated from UARTBn.

- Reception completion interrupt request signal (INTUBnTIR)
- Transmission enable interrupt request signal (INTUBnTIT)
- FIFO transmission completion interrupt request signal (INTUBnTIF)
- Reception error interrupt request signal (INTUBnTIRE)
- Reception timeout interrupt request signal (INTUBnTITO)

The default priorities among these five types of interrupt requests is, from high to low, reception completion interrupt request signal, transmission enable interrupt request signal, FIFO transmission completion interrupt request signal, reception error interrupt request signal, and reception timeout interrupt request signal.

**Table 16-3. Generated Interrupts and Default Priorities**

Interrupt	Priority
Reception completion	1
Transmission enable	2
FIFO transmission completion	3
Reception error	4
Reception timeout	5

### (1) Reception error interrupt request signal (INTUBnTIRE)

#### (a) Single mode

When reception is enabled, a reception error interrupt request signal is generated according to the logical OR of the three types of reception errors (parity error, framing error, overrun error) explained for the UBnSTR register.

When reception is disabled, no reception error interrupt request signal is generated.

#### (b) FIFO mode

When reception is enabled, a reception error interrupt request signal is generated according to the logical OR of the three types of reception errors (parity error, framing error, overflow error) explained for the UBnSTR register.

When reception is disabled, no reception error interrupt request signal is generated.

**(2) Reception completion interrupt request signal (INTUBnTIR)****(a) Single mode**

When reception is enabled, a reception completion interrupt request signal is generated if data is shifted into the receive shift register n and stored in the UBnRX register (if the receive data can be read).

When reception is disabled, no reception completion interrupt request signal is generated.

**(b) FIFO mode**

When reception is enabled, a reception completion interrupt request signal is generated if data is shifted into the receive shift register n and receive data of the number set as the trigger by the UBnFIC2.UBnRT3 to UBnFIC2.UBnRT0 bits is transferred to receive FIFO n (if receive data of the specified number can be read).

When reception is disabled, no reception completion interrupt request signal is generated.

**(3) Transmission enable interrupt request signal (INTUBnTIT)****(a) Single mode**

The transmission enable interrupt request signal is generated if transmit data of one frame, including 7 or 8 bits of characters, is shifted out from the transmit shift register n and the UBnTX register becomes empty (if transmit data can be written).

**(b) FIFO mode**

The transmission enable interrupt request signal is generated if transmit data of the number set as the trigger by the UBnFIC2.UBnTT3 to UBnFIC2.UBnTT0 bits is transferred to the transmit shift register n from transmit FIFO n (if transmit data of the specified number can be written).

**(4) FIFO transmission completion interrupt request signal (INTUBnTIF)****(a) Single mode**

Cannot be used.

**(b) FIFO mode**

The FIFO transmission completion interrupt request signal is generated when no more data is in transmit FIFO n and the transmit shift register n (when the FIFO and register become empty). After the FIFO transmission completion interrupt request signal has occurred, clear the interrupt request signal (INTUBnTIF) held pending in the pending mode (UBnFIC0.UBnITM bit = 0) by clearing the FIFO (UBnFIC0.UBnTFC bit = 1).

**Caution** If the FIFO transmission completion interrupt request signal is generated (all transmit data are not transmitted) because writing the next transmit data to transmit FIFO n is delayed, do not clear the FIFO.

**(5) Reception timeout interrupt request signal (INTUBnTITO)****(a) Single mode**

Cannot be used.

**(b) FIFO mode**

The reception timeout interrupt request signal is generated if data is stored in receive FIFO when the next data does not come (start bit is not detected) even after the next data reception wait time specified by the UBnFIC1.UBnTC4 to UBnFIC1.UBnTC0 bits has elapsed, when the timeout counter function is used (UBnFIC1.UBnTCE bit = 1).

The reception timeout interrupt request signal is not generated while reception is disabled.

If receive data of the number set as the trigger by the UBnFIC2.UBnRT3 to UBnFIC2.UBnRT0 bits is not received, the timing of reading the number of receive data less than the specified number can be set by the reception timeout interrupt request signal.

Since the timeout counter starts counting at start bit detection, a receive timeout interrupt request signal does not occur if data of 1 character has not been received.

## 16.5 Control Modes

### (1) Single mode/FIFO mode

The single mode or FIFO mode can be selected by using the UBnFIC0.UBnMOD bit.

**Caution** Be sure to select the single mode when writing a transmit data or reading a received data by using the DMA control. In FIFO mode, the use of the DMA control is prohibited.

#### (a) Single mode

- Each of the UBnRX and UBnTX registers consists of 8 bits  $\times$  1 stage.
- When 1 byte of data is received, the INTUBnTIR signal is generated.
- If the next reception operation of UARTBn is completed before the receive data of the UBnRX register is read after the INTUBnTIR signal has been generated, the INTUBnTIRE signal is generated and an overrun error occurs.

#### (b) FIFO mode

- Receive FIFO (UBnRXAP register) consists of 16 bits  $\times$  16 stages and transmit FIFO consists of 8 bits  $\times$  16 stages.
- Receive FIFO can recognize error data by reading the 16-bit UBnRXAP register only when a reception error (parity error or framing error) occurs.
- Transmission is started when transmission is enabled (UBnCTL0.UBnTXE bit = 1) after transmit data of at least the number set as the trigger by the UBnFIC2.UBnTT3 to UBnFIC2.UBnTT0 bits and 16 bytes or less are written to transmit FIFO.
- The pending mode or pointer mode can be selected for the generation timing of the INTUBnTIT and INTUBnTIR signals.

**(2) Pending mode/pointer mode**

The pending mode or pointer mode can be selected by using the UBnFIC0.UBnITM and UBnFIC0.UBnIRM bits in the FIFO mode (UBnFIC0.UBnMOD bit = 1).

If transmission is started by writing data of more than double the amount set as the trigger by the UBnFIC2.UBnTT3 to UBnFIC2.UBnTT0 bits to transmit FIFO, the transmission enable interrupt request signal (INTUBnTIT) may occur more than once. The reception completion interrupt request signal (INTUBnTIR) may also occur more than once if the number of receive data set as the trigger by the UBnFIC2.UBnRT3 to UBnFIC2.UBnRT0 bits is 8 bytes or less in receive FIFO. In the pending or pointer mode, it can be specified how an interrupt is handled after it has been held pending.

**(a) Pending mode****(i) During transmission (writing to transmit FIFO)**

- If the data of the first transmission enable interrupt request signal (INTUBnTIT) is not written to transmit FIFO after the interrupt has occurred, the second INTUBnTIT signal does not occur (is held pending) even if the generation condition of the second INTUBnTIT signal is satisfied (when transmit data of the number set as the trigger by the UBnFIC2.UBnTT3 to UBnFIC2.UBnTT0 bits is transferred from transmit FIFO to the transmit shift register n).

When data for the first INTUBnTIT signal is later written to transmit FIFO, the pending INTUBnTIT signal is generated<sup>Note</sup>.

**Note** The number of pending interrupts is as follows.

When trigger is set to 1 byte (UBnFIC2.UBnTT3 to UBnFIC2.UBnTT0 bits = 0000): 15 times max.

When trigger is set to 2 bytes (UBnFIC2.UBnTT3 to UBnFIC2.UBnTT0 bits = 0001): 7 times max.

:

When trigger is set to 6 bytes (UBnFIC2.UBnTT3 to UBnFIC2.UBnTT0 bits = 0101): 1 time max.

When trigger is set to 7 bytes (UBnFIC2.UBnTT3 to UBnFIC2.UBnTT0 bits = 0110): 1 time max.

When trigger is set to 8 bytes (UBnFIC2.UBnTT3 to UBnFIC2.UBnTT0 bits = 0111): 1 time max.

- In the pending mode, transmit data of the number set as the trigger by the UBnFIC2.UBnTT3 to UBnFIC2.UBnTT0 bits is always written to transmit FIFO when the transmission enable interrupt request signal (INTUBnTIT) occurs. Writing data to transmit FIFO is prohibited if the data is more or less than the specified number. If data more or less than the specified number is written, the operation is not guaranteed.

**(ii) During reception (reading from receive FIFO)**

- If data for the first reception completion interrupt request signal (INTUBnTIR) is not read from receive FIFO, the second INTUBnTIR signal does not occur (is held pending) even if the generation condition of the second INTUBnTIR is satisfied (if receive data of the number set as the trigger by the UBnFIC2.UBnRT3 to UBnFIC2.UBnRT0 bits can be read from receive FIFO). When data for the first INTUBnTIR signal is later read from the receive FIFO, the pending INTUBnTIR signal is generated<sup>Note</sup>.

**Note** The number of pending interrupts is as follows.

When trigger is set to 1 byte (UBnFIC2.UBnRT3 to UBnFIC2.UBnRT0 bits = 0000): 15 times max.

When trigger is set to 2 bytes (UBnFIC2.UBnRT3 to UBnFIC2.UBnRT0 bits = 0001): 7 times max.

:

When trigger is set to 6 bytes (UBnFIC2.UBnRT3 to UBnFIC2.UBnRT0 bits = 0101): 1 time max.

When trigger is set to 7 bytes (UBnFIC2.UBnRT3 to UBnFIC2.UBnRT0 bits = 0110): 1 time max.

When trigger is set to 8 bytes (UBnFIC2.UBnRT3 to UBnFIC2.UBnRT0 bits = 0111): 1 time max.

- In the pending mode, receive data of the number set as the trigger by the UBnFIC2.UBnRT3 to UBnFIC2.UBnRT0 bits is always read from receive FIFO when the reception completion interrupt request signal (INTUBnTIR) occurs. Reading data from receive FIFO is prohibited if the data is more or less than the specified number. If data more or less than the specified number is read, the operation is not guaranteed.

**(b) Pointer mode****(i) During transmission (writing to transmit FIFO)**

- Each time the data of 1 byte is transferred to the transmit shift register n from transmit FIFO, a transmission enable interrupt request signal (INTUBnTIT) occurs.
- In the pointer mode, be sure to fix the UBnFIC2.UBnTT3 to UBnFIC2.UBnTT0 bits to 0000 (set number of transmit data: 1 byte) as the number of transmit data set as the trigger for transmit FIFO when the transmission enable interrupt request signal (INTUBnTIT) occurs. If any other setting is made, the operation is not guaranteed.
- After the transmission enable interrupt request signal (INTUBnTIT) has been acknowledged, data of the number of empty bytes of transmit FIFO can be written to transmit FIFO by referencing the UBnFIS1 register.

**(ii) During reception (reading from receive FIFO)**

- Each time the data of 1 byte is transferred to receive FIFO from the receive shift register n, a reception completion interrupt request signal (INTUBnTIR) occurs.
- In the pointer mode, be sure to fix the UBnFIC2.UBnRT3 to UBnFIC2.UBnRT0 bits to 0000 (set number of receive data: 1 byte) as the number of receive data set as the trigger for receive FIFO when the reception completion interrupt request signal (INTUBnTIR) occurs. If any other setting is made, the operation is not guaranteed.
- After the reception completion interrupt request signal (INTUBnTIR) has been acknowledged, data of the number of bytes stored in receive FIFO can be read from receive FIFO by referencing the UBnFIS0 register. In some cases, however, data is not stored in receive FIFO even though the INTUBnTIR signal is generated (UBnFIS0.UBnRB4 to UBnFIS0.UBnRB0 bits = 00000). In these cases, do not read data from receive FIFO. Always read data from receive FIFO when the number of bytes stored in receive FIFO is 1 byte or more (UBnRB4 to UBnRB0 bits = other than 00000).



## 16.6 Operation

### 16.6.1 Data format

Full-duplex serial data transmission and reception can be performed.

The transmit/receive data format consists of one data frame containing a start bit, character bits, a parity bit, and stop bits as shown in Figure 16-2.

The character bit length within one data frame, the type of parity, and the stop bit length are specified by UARTBn control register 0 (UBnCTL0).

Also, data is transferred with LSB first/MSB first.

**Figure 16-2. Asynchronous Serial Interface Transmit/Receive Data Format (LSB-First Transfer)**

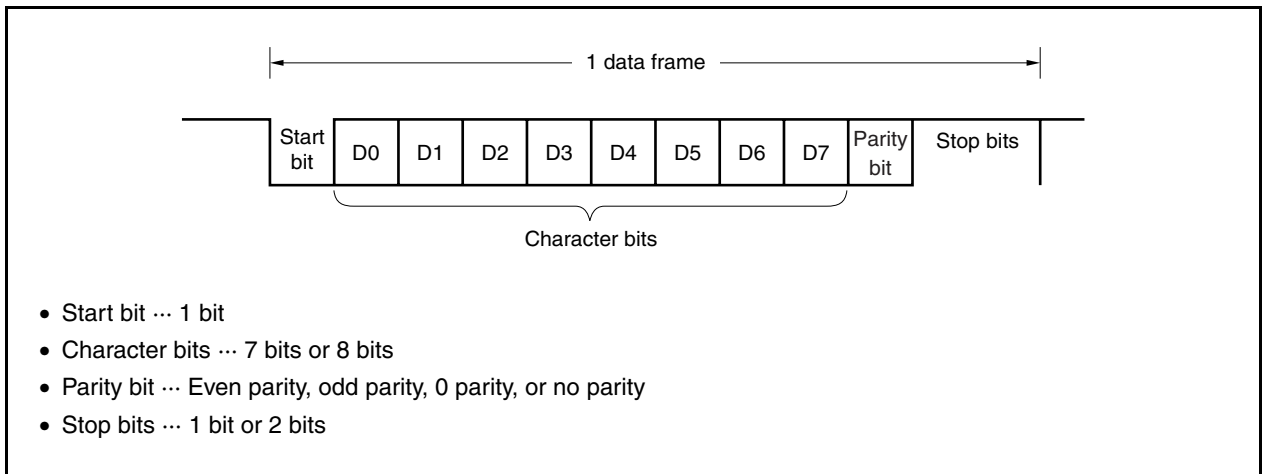

### 16.6.2 Transmit operation

In the single mode (UBnFIC0.UBnMOD bit = 0), transmission is enabled when the UBnCTL0.UBnTXE bit is set to 1, and transmission is started when transmit data is written to the UBnTX register.

In the FIFO mode (UBnFIC0.UBnMOD bit = 1), transmission is started when transmit data of at least the number set as the trigger by the UBnFIC2.UBnTT3 to UBnFIC2.UBnTT0 bits and 16 bytes or less is written to transmit FIFO and then the UBnTXE bit is set to 1.

**Caution** Setting the UBnCTL0.UBnTXE bit to 1 before writing transmit data to transmit FIFO in the FIFO mode is prohibited. The operation is not guaranteed if this setting is made.

#### (1) Transmission enabled state

This state is set by the UBnCTL0.UBnTXE bit.

- UBnTXE = 1: Transmission enabled state
- UBnTXE = 0: Transmission disabled state

Since UARTBn does not have a CTS (transmission enabled signal) input pin, a port should be used to confirm whether the destination is in the reception enabled state.

#### (2) Starting a transmit operation

- **In single mode (UBnFIC0.UBnMOD bit = 0)**

In the single mode, transmission is started when transmit data is written to the UBnTX register while transmission is enabled.

- **In FIFO mode (UBnFIC0.UBnMOD bit = 1)**

In the FIFO mode, transmission is started when transmit data of at least the number set as the trigger by the UBnFIC2.UBnTT3 to UBnFIC2.UBnTT0 bits and 16 bytes or less is written to transmit FIFO and then transmission is enabled (UBnTXE bit = 1).

Data in the transmit data register n (UBnTX register in single mode or transmit FIFO in the FIFO mode) is transferred to the transmit shift register n when transmission is started. Then, the transmit shift register n outputs data to the TXDBn pin sequentially beginning with the LSB (the transmit data is transferred sequentially starting with the start bit). The start bit, parity bit, and stop bits are added automatically.

**(3) Transmission interrupt request signal****(a) Transmission enable interrupt request signal (INTUBnTIT)**

- **In single mode (UBnFIC0.UBnMOD bit = 0)**

In the single mode, the transmission enable interrupt request signal (INTUBnTIT) occurs when transmit data can be written to the UBnTX register (when 1 byte of data is transferred from the UBnTX register to the transmit shift register n).

- **In FIFO mode (UBnFIC0.UBnMOD bit = 1)**

In the FIFO mode, the INTUBnTIT signal occurs when transmit data of the number set as the trigger specified by the UBnFIC2.UBnTT3 to UBnFIC2.UBnTT0 bits is transferred from transmit FIFO<sub>n</sub> to the transmit shift register n (if transmit data of the number set as the trigger can be written).

- **If pending mode is specified (UBnFIC0.UBnITM bit = 0) in FIFO mode**

If the pending mode is specified in the FIFO mode, the second INTUBnTIT signal is held pending after the first INTUBnTIT signal has occurred, until as many transmit data as the number set as the trigger by the UBnFIC2.UBnTT3 to UBnFIC2.UBnTT0 bits are written to transmit FIFO<sub>n</sub>, even if the generation condition of the second INTUBnTIT signal is satisfied. When as many transmit data as the number set as the trigger are written to transmit FIFO<sub>n</sub> in response to the first INTUBnTIT signal, the second pending INTUBnTIT signal is generated.

- **If pointer mode is specified (UBnFIC0.UBnITM bit = 1) in FIFO mode**

If the pointer mode is specified in the FIFO mode, the second INTUBnTIT signal occurs when the generation condition of the second INTUBnTIT signal is satisfied even if as many transmit data as the number set as the trigger by the UBnFIC2.UBnTT3 to UBnFIC2.UBnTT0 bits are not written to transmit FIFO<sub>n</sub> when the first INTUBnTIT signal occurs.

**(b) FIFO transmission completion interrupt request signal (INTUBnTIF)**

The FIFO transmission completion interrupt request signal (INTUBnTIF) occurs when no more data is in transmit FIFO and the transmit shift register n in the FIFO mode (UBnFIC0.UBnMOD bit = 1). After the INTUBnTIF signal has occurred, clear the pending INTUBnTIT signal in the pending mode (UBnFIC0.UBnITM bit = 0) by clearing the FIFO (UBnFIC0.UBnTFC bit = 1). If the INTUBnTIF signal occurs because writing the next transmit data to transmit FIFO<sub>n</sub> is delayed (if all transmit data have not been transmitted), do not clear the FIFO.

If the data to be transmitted next has not been written to the transmit data register n, the transmit operation is suspended.

**Caution** In the single mode, the transmission enable interrupt request signal (INTUBnTIT) occurs when the UBnTX register becomes empty (when 1 byte of data is transferred from the UBnTX register to the transmit shift register n). In the FIFO mode, the FIFO transmission completion interrupt request signal (INTUBnTIF) occurs when data is no longer in transmit FIFO<sub>n</sub> and the transmit shift register n (when the FIFO and register are empty). However, the INTUBnTIT signal or INTUBnTIF signal is not generated if the transmit data register n becomes empty due to RESET input.

**Figure 16-3. Timing of Asynchronous Serial Interface Transmission Enable Interrupt Request Signal (INTUBnTIT)**

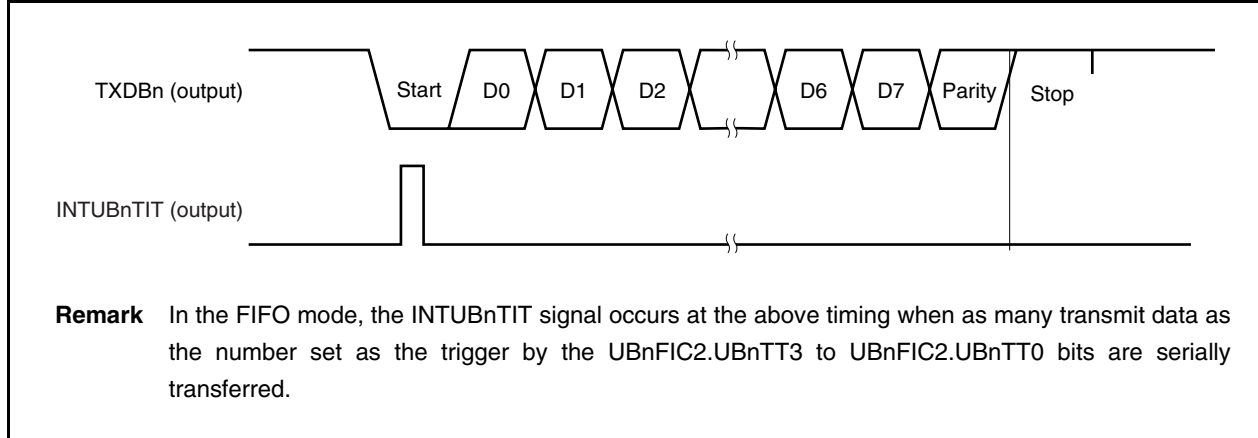

**Figure 16-4. Timing of Asynchronous Serial Interface FIFO Transmission Completion Interrupt Request Signal (INTUBnTIF)**

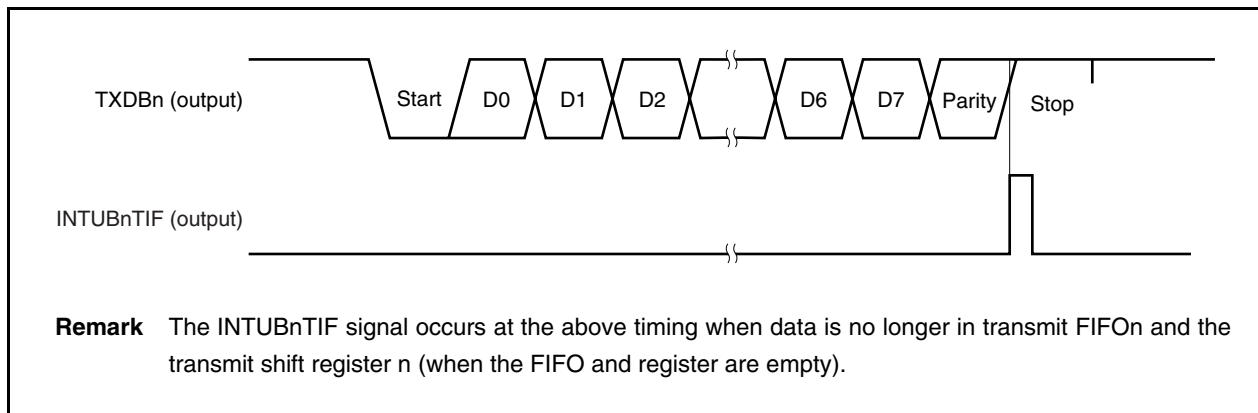

### 16.6.3 Continuous transmission operation

**Cautions 1. Be sure to check whether the transmission has been completed before performing initialization during the transmission processing (UBnSTR.UBnTSF bit = 0, but it can be checked by the generation of the FIFO transmission completion interrupt request signal (INTUBnTIF) in the FIFO mode.)**

**2. Be sure to select the single mode when writing a transmit data or reading a received data by using the DMA control. In FIFO mode, the use of the DMA control is prohibited.**

- **In single mode (UBnFIC0.UBnMOD bit = 0)**

In the single mode, the next data can be written to the UBnTX register as soon as the transmit shift register n has started a shift operation. The timing of transfer can be identified by the transmission enable interrupt request signal (INTUBnTIT). By writing the next transmit data to the UBnTX register via the INTUBnTIT signal within one data frame transmission period, data can be transmitted without an interval and an efficient communication rate can be realized.

- **If pending mode is specified (UBnFIC0.UBnITM bit = 0) in FIFO mode**

If transmit data of at least the number set as the transmit trigger by UBnFIC2.UBnTT3 to UBnFIC2.UBnTT0 bits and 16 bytes or less is written to transmit FIFO<sub>n</sub>, transmission starts.

If the pending mode is specified in the FIFO mode, as many of the next transmit data as the number set as the trigger by the UBnFIC2.UBnTT3 to UBnFIC2.UBnTT0 bits can be written to transmit FIFO<sub>n</sub> as soon as the transmit shift register n has started shifting the last data of the specified number of data. The timing of transfer can be identified by the INTUBnTIT signal. By writing as many of the next transmit data as the number set as the trigger to transmit FIFO<sub>n</sub> or writing the next transmit data to the transmit FIFO<sub>n</sub> within the transmission period of the data in transmit FIFO<sub>n</sub> via the INTUBnTIT signal, data can be transmitted without an interval and an efficient communication rate can be realized.

- **If pointer mode is specified (UBnFIC0.UBnITM bit = 1) in FIFO mode**

If the pointer mode is specified in the FIFO mode, a INTUBnTIT signal occurs and the next data can be written to transmit FIFO<sub>n</sub> as soon as the transmit shift register n has started shifting the number of transmit data set as the trigger. At this time, as many data as the number of empty bytes of transmit FIFO<sub>n</sub> can be written by referencing the UBnFIS1 register. The timing of transfer can be identified by the INTUBnTIT signal. By writing as many of the next transmit data as the number specified as the trigger to transmit FIFO<sub>n</sub> or writing the next transmit data to the transmit FIFO<sub>n</sub> within the transmission period of the data in transmit FIFO<sub>n</sub> via the INTUBnTIT signal, data can be transmitted without an interval and an efficient communication rate can be realized.

#### 16.6.4 Receive operation

The awaiting reception state is set by setting the `UBnCTL0.UBnPWR` bit to 1 and then setting the `UBnCTL0.UBnRXE` bit to 1. `RXDn` pin sampling begins and a start bit is detected. When the start bit is detected, the receive operation begins, and data is stored sequentially in the receive shift register `n` according to the baud rate that was set.

In the single mode (`UBnFIC0.UBnMOD` bit = 0), a reception completion interrupt request signal (`INTUBnTIR`) is generated each time the reception of one frame of data is completed. Normally, the receive data is transferred from the `UBnRX` register to memory by this interrupt servicing.

In the FIFO mode (`UBnFIC0.UBnMOD` bit = 1), the `INTUBnTIR` signal occurs when as many receive data as the number set as the trigger by the `UBnFIC2.UBnRT3` to `UBnFIC2.UBnRT0` bits are transferred to receive FIFO.

If the pending mode is specified (`UBnFIC0.UBnIRM` bit = 0) in the FIFO mode, as many receive data as the number set as the trigger by the `UBnFIC2.UBnRT3` to `UBnFIC2.UBnRT0` bits can be read from receive FIFO.

If the pointer mode is specified (`UBnFIC0.UBnIRM` bit = 1) in the FIFO mode, as many data as the number of bytes stored in receive FIFO (0 bytes or more) can be read from receive FIFO by referencing the number of receive data specified as the trigger by the `UBnRT3` to `UBnRT0` bits (1 byte) or the `UBnFIS0` register.

- Cautions 1.** If the pointer mode is specified in the FIFO mode and if as many data as the number of bytes stored in receive FIFO are read by referencing the `UBnFIS0` register, no data may be stored in receive FIFO (`UBnFIS0.UBnRB4` to `UBnFIS0.UBnRB0` bits = 00000) even though the reception completion interrupt request signal (`INTUBnTIR`) has occurred. In this case, do not read data from receive FIFO. Be sure to read data from receive FIFO after confirming that the number of bytes stored in receive FIFO = 1 byte or more (`UBnRB4` to `UBnRB0` bits = other than 00000).
- 2.** Be sure to select the single mode when reading a received data by using the DMA control. In FIFO mode, use of the DMA control is prohibited.

##### (1) Reception enabled state

This state is set by the `UBnCTL0.UBnRXE` bit.

- `UBnRXE` = 1: Reception enabled state
- `UBnRXE` = 0: Reception disabled state

In the reception disabled state, the reception hardware stands by in the initial state. At this time, the reception completion interrupt request signal or reception error interrupt request signal does not occur, and the contents of the receive data register `n` (`UBnRX` register in the single mode or receive FIFO in the FIFO mode (`UBnRXAP` register)) are retained.

##### (2) Starting a receive operation

A receive operation is started by the detection of a start bit.

The `RXDn` pin is sampled using the serial clock from `UARTBn` control register 2 (`UBnCTL2`).

**(3) Reception interrupt request signal****(a) Reception completion interrupt request signal (INTUBnTIR)****• In single mode (UBnFIC0.UBnMOD bit = 0)**

When UBnCTL0.UBnRXE bit = 1 and the reception of one frame of data is completed (the stop bit is detected) in the single mode, a reception completion interrupt request signal (INTUBnTIR) is generated and the receive data in the receive shift register n is transferred to the UBnRX register at the same time.

Also, if an overrun error occurs, the receive data at that time is not transferred to the UBnRX register, and a reception error interrupt request signal (INTUBnTIRE) is generated.

If a parity error or framing error occurs during the reception operation, the reception operation continues up to the position at which the stop bit is received. After completion of reception, an INTUBnTIRE signal occurs (the receive data in the receive shift register n is transferred to the UBnRX register).

If the UBnRXE bit is reset (0) during a receive operation, the receive operation is immediately stopped. At this time, the contents of the UBnRX register remain unchanged, the contents of the UARTBn status register (UBnSTR) are cleared, and the INTUBnTIR and INTUBnTIRE signals do not occur.

No INTUBnTIR signal is generated when the UBnRXE bit = 0 (reception is disabled).

**• In FIFO mode (UBnFIC0.UBnMOD bit = 1)**

In the FIFO mode, the reception completion interrupt request signal (INTUBnTIR) occurs when data of one frame has been received (stop bit is detected) and when as many receive data as the number specified as the trigger by the UBnFIC2.UBnRT3 to UBnFIC2.UBnRT0 bits are transferred from the receive shift register to receive FIFO. If an overflow error occurs, the receive data is not transferred to receive FIFO and the reception error interrupt request signal (INTUBnTIRE) occurs.

If a parity error or framing error occurs during reception, reception continues up to the reception position of the stop bit. After reception has been completed, the INTUBnTIRE signal occurs and the receive data in the receive shift register n is transferred to receive FIFO. At this time, error information is appended as the UBnRXAP.UBnPEF or UBnRXAP.UBnFEF bit = 1. If the INTUBnTIRE signal occurs, the error data can be recognized by reading receive FIFO as a 16-bit register, UBnRXAP.

**(b) Reception timeout interrupt request signal (INTUBnTITO) (only in FIFO mode)**

When the timeout counter function (UBnFIC1.UBnTCE bit = 1) is used in the FIFO mode, the reception timeout interrupt request signal (INTUBnTITO) occurs if the next data does not come even after the next data reception wait time specified by the UBnFIC1.UBnTC4 to UBnFIC1.UBnTC0 bits has elapsed and if data is stored in receive FIFO.

The INTUBnTITO signal does not occur while reception is disabled.

If as many receive data as the number set as the trigger by the UBnFIC2.UBnRT3 to UBnFIC2.UBnRT0 bits are not received, the timing of reading less receive data than the specified number can be set by the INTUBnTITO signal.

Since the timeout counter starts counting at start bit detection, a receive timeout interrupt request signal does not occur if data of 1 character has not been received.

**Figure 16-5. Timing of Asynchronous Serial Interface Reception Completion Interrupt Request Signal (INTUBnTIR)**

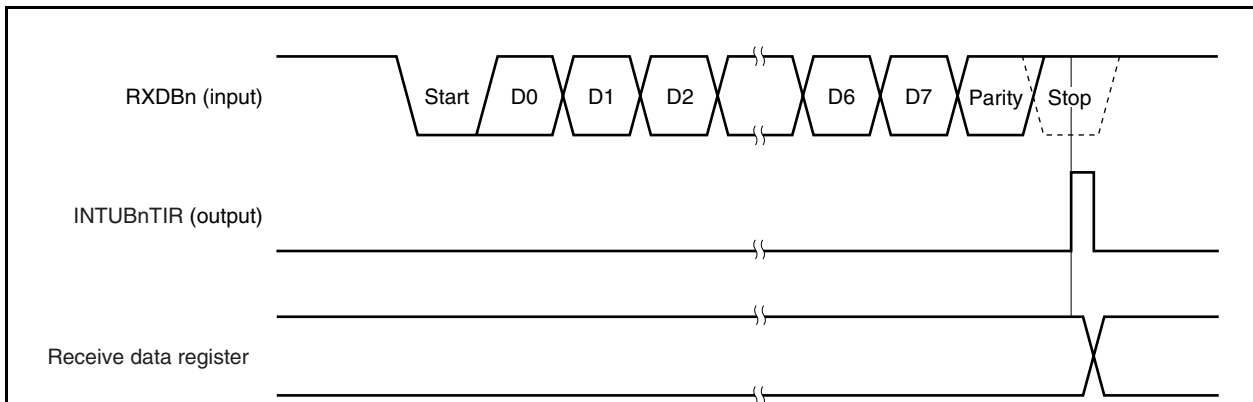

**Cautions 1.** Be sure to read all the data (the number of data indicated by the UBnFIS0.UBnRB4 to UBnFIS0.UBnRB0 bits) stored in the receive data register n (UBnRX register in the single mode or receive FIFO in the FIFO mode (UBnRXAP register)) even when a reception error occurs.

Unless the receive data register is read, an overrun error occurs when the next data is received, causing the reception error status to persist.

If the pending mode is specified in the FIFO mode, however, be sure to clear the FIFO (UBnFIC0.UBnRFC bit = 1) after reading the data stored in receive FIFO.

In the FIFO mode, the FIFO can be cleared even without reading the data stored in receive FIFO.

If a parity error or framing error occurs in the FIFO mode, the UBnRXAP register can be read in 16-bit (halfword) units.

**2.** Data is always received with one stop bit (1).

A second stop bit is ignored.



### 16.6.5 Reception error

In the single mode (UBnFIC0.UBnMOD bit = 0), the three types of errors that can occur during a receive operation are a parity error, framing error, and overrun error. In the FIFO mode (UBnFIC0.UBnMOD bit = 1), the three types of errors that can occur during a receive operation are a parity error, framing error, and overflow error.

As a result of data reception, the UBnSTR.UBnPE, UBnSTR.UBnFE, or UBnSTR.UBnOVE bit is set to 1 if a parity error, framing error, or overrun error occurs in the single mode. The UBnSTR.UBOVF bit is set to 1 if an overflow error occurs in the FIFO mode. The UBnRXAP.UBnPEF or UBnRXAP.UBnFEF bit is set to 1 if a parity error or framing error occurs in the FIFO mode. At the same time, a reception error interrupt request signal (INTUBnTIRE) occurs. The contents of the error can be detected by reading the contents of the UBnSTR or UBnRXAP register.

The contents of the UBnSTR register are reset when 0 is written to the UBnOVF, UBnPE, UBnFE, or UBnOVE bit, or the UBnCTL0.UBnPWR or UBnCTL0.UBnRXE bit. The contents of the UBnRXAP register are reset when 0 is written to the UBnCTL0.UBnPWR bit.

**Table 16-4. Reception Error Causes**

Error Flag	Valid Operation Mode	Error Flag	Reception Error	Cause
UBnPE	Single mode	UBnPE	Parity error	The parity specification during transmission does not match the parity of the receive data
UBnFE		UBnFE	Framing error	No stop bit detected
UBnOVE		UBnOVE	Overrun error	The reception of the next data is completed before data is read from the UBnRX register
UBnOVF	FIFO mode	UBnOVF	Overflow error	The reception of the next data is completed while receive FIFO is full and before data is read.
UBnPEF		UBnPEF	Parity error	The parity specification during transmission does not match the parity of the data to be received.
UBnFEF		UBnFEF	Framing error	The stop bit is not detected when the target data is loaded.

**16.6.6 Parity types and corresponding operation**

A parity bit is used to detect a bit error in communication data. Normally, the same type of parity bit is used at the transmission and reception sides.

**(1) Even parity****(a) During transmission**

The parity bit is controlled so that the number of bits with the value “1” within the transmit data including the parity bit is even. The parity bit value is as follows.

- If the number of bits with the value “1” within the transmit data is odd: 1
- If the number of bits with the value “1” within the transmit data is even: 0

**(b) During reception**

The number of bits with the value “1” within the receive data including the parity bit is counted, and a parity error is generated if this number is odd.

**(2) Odd parity****(a) During transmission**

In contrast to even parity, the parity bit is controlled so that the number of bits with the value “1” within the transmit data including the parity bit is odd. The parity bit value is as follows.

- If the number of bits with the value “1” within the transmit data is odd: 0
- If the number of bits with the value “1” within the transmit data is even: 1

**(b) During reception**

The number of bits with the value “1” within the receive data including the parity bit is counted, and a parity error is generated if this number is even.

**(3) 0 parity**

During transmission the parity bit is set to “0” regardless of the transmit data.

During reception, no parity bit check is performed. Therefore, no parity error is generated regardless of whether the parity bit is “0” or “1”.

**(4) No parity**

No parity bit is added to the transmit data.

During reception, the receive operation is performed as if there were no parity bit. Since there is no parity bit, no parity error is generated.

### 16.6.7 Receive data noise filter

The RXDBn signal is sampled at the rising edge of the peripheral clock ( $f_{XP}$ ). If the same sampling value is obtained twice, the match detector output changes, and this output is sampled as input data. Therefore, data not exceeding one clock width is judged to be noise and is not delivered to the internal circuit (see **Figure 16-7**).

Also, since the circuit is configured as shown in Figure 16-6, internal processing during a receive operation is delayed by up to 2 clocks according to the external signal status.

**Figure 16-6. Noise Filter Circuit**

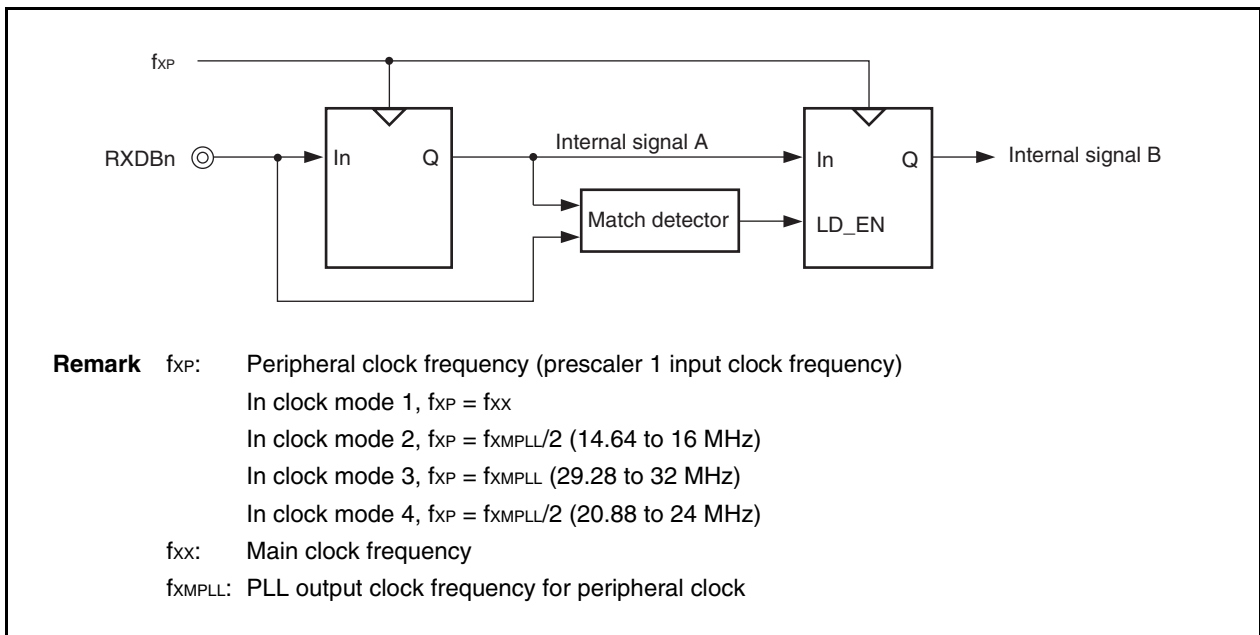
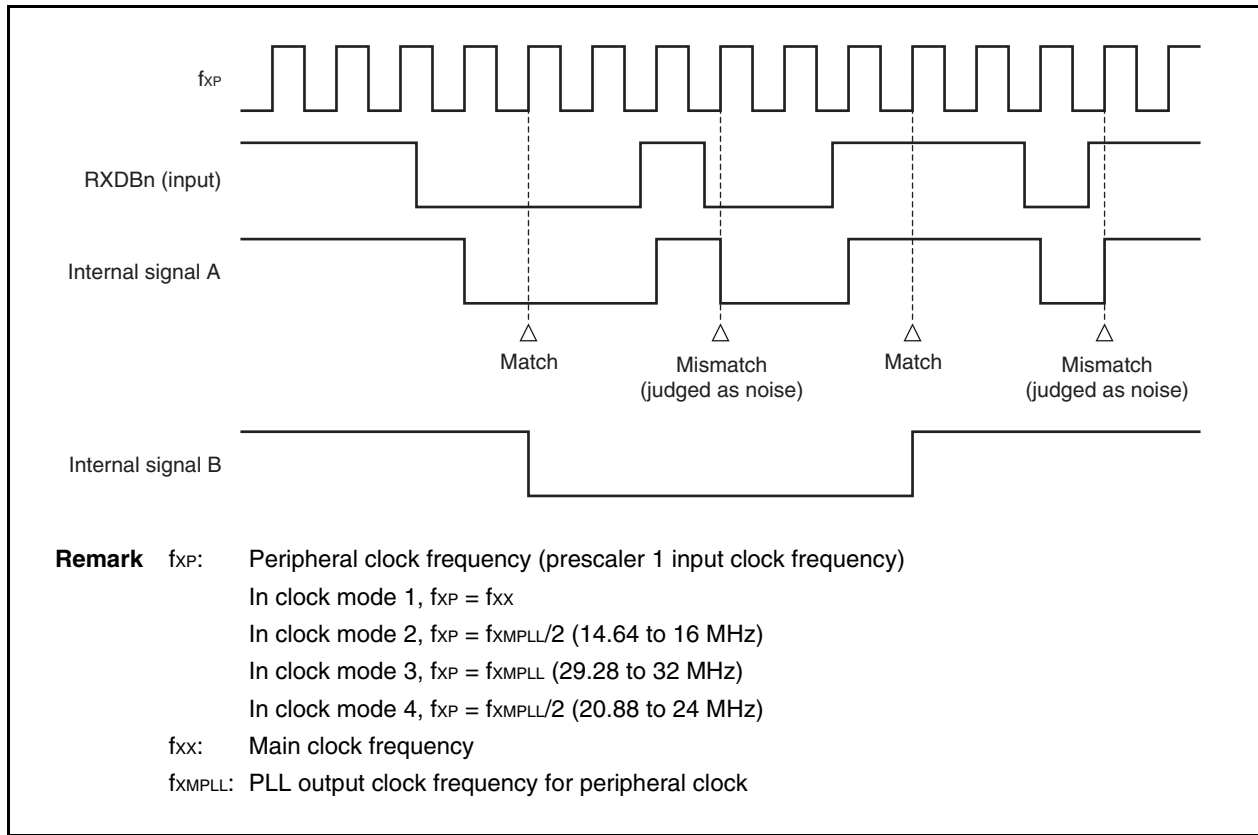

Figure 16-7. Timing of RXDBn Signal Judged as Noise



## 16.7 Dedicated Baud Rate Generator (BRG)

A dedicated baud rate generator, which consists of a 16-bit programmable counter, generates serial clocks during transmission/reception in UARTBn. The dedicated baud rate generator output can be selected as the serial clock for each channel.

Separate 16-bit counters exist for transmission and for reception. The baud rate for transmission/reception is the same at the same channel.

### (1) Baud rate generator configuration

Figure 16-8. Baud Rate Generator Configuration

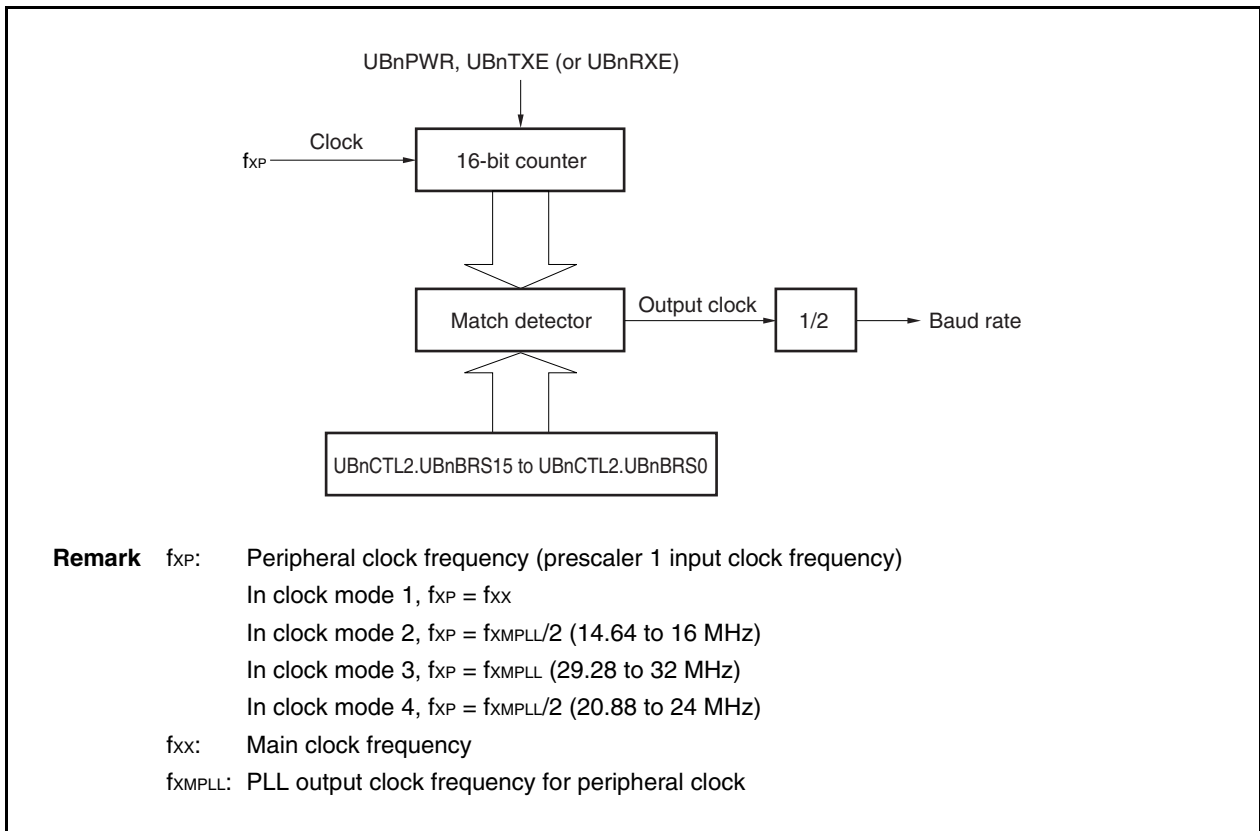

#### (a) Base clock (Clock)

When UBnCTL0.UBnPWR bit = 1, the peripheral clock ( $f_{XP}$ ) is supplied to the transmission/reception unit. This clock is called the base clock (Clock).

**(2) Serial clock generation**

A serial clock can be generated according to the settings of the UBnCTL2 register.

The 16-bit counter divisor value can be selected according to the UBnCTL2.UBnBRS15 to UBnCTL2.UBnBRS0 bits.

**(a) Baud rate**

The baud rate is the value obtained according to the following formula.

$$\text{Baud rate} = \frac{f_{XP}}{2 \times k} \text{ [bps]}$$

$f_{XP}$ : Peripheral clock frequency (prescaler 1 input clock frequency)

In clock mode 1,  $f_{XP} = f_{XX}$

In clock mode 2,  $f_{XP} = f_{XMPLL}/2$  (14.64 to 16 MHz)

In clock mode 3,  $f_{XP} = f_{XMPLL}$  (29.28 to 32 MHz)

In clock mode 4,  $f_{XP} = f_{XMPLL}/2$  (20.88 to 24 MHz)

$f_{XX}$ : Main clock frequency

$f_{XMPLL}$ : PLL output clock frequency for peripheral clock

$k$  = Value set according to UBnCTL2.UBnBRS15 to UBnCTL2.UBnBRS0 bits ( $k = 4, 5, 6, \dots, 65535$ )

**(b) Baud rate error**

The baud rate error is obtained according to the following formula.

$$\text{Error (\%)} = \left( \frac{\text{Actual baud rate (baud rate with error)}}{\text{Desired baud rate (normal baud rate)}} - 1 \right) \times 100 \text{ [\%]}$$

**Cautions 1. Make sure that the baud rate error during transmission does not exceed the allowable error of the reception destination.**

**2. Make sure that the baud rate error during reception is within the allowable baud rate range during reception, which is described in paragraph (4).**

**Example:**  $f_{XP} = 32 \text{ MHz} = 32,000,000 \text{ Hz}$

Settings of UBnCTL2.UBnBRS15 to UBnCTL2.UBnBRS0 bits = 0000000000110011B  
( $k = 51$ )

Target baud rate = 312500 bps

Baud rate =  $32 \text{ M}/(2 \times 51)$   
=  $32000000/(2 \times 51) = 313725 \text{ [bps]}$

Error =  $(313725/312500 - 1) \times 100$   
= 0.392 [%]

**(3) Baud rate setting example****Table 16-5. Baud Rate Generator Setting Data (1/2)**

Baud Rate (bps)	$f_{XP} = 32 \text{ MHz}$		$f_{XP} = 24 \text{ MHz}$		$f_{XP} = 16 \text{ MHz}$	
	UBnCTL2	ERR (%)	UBnCTL2	ERR (%)	UBnCTL2	ERR (%)
300	D055H	0.00	9C40H	0.00	682BH	0.00
600	682BH	0.00	4E20H	0.00	3415H	0.00
1200	3415H	0.00	2710H	0.00	1A0BH	0.00
2400	1A0BH	0.00	1388H	0.00	0D05H	0.01
4800	0D05H	0.01	09C4H	0.00	0683H	-0.02
9600	0683H	-0.02	04E2H	0.00	0341H	0.04
19200	0341H	0.04	0271H	0.00	01A1H	-0.08
31250	0200H	0.00	0180H	0.00	0100H	0.00
38400	01A1H	-0.08	0139H	-0.16	00D0H	0.16
76800	00D0H	0.16	009CH	0.16	0068H	0.16
153600	0068H	0.16	004EH	0.16	0034H	0.16
312500	0033H	0.39	0026H	1.05	001AH	-1.54
500000	0020H	0.00	0018H	0.00	0010H	0.00
625000	001AH	-1.54	0013H	1.05	000DH	-1.54
1500000	000BH	-3.03	0008H	0.00	0006H	-11.11

&lt;R&gt;

&lt;R&gt;

**Caution** The maximum transfer speed of the baud rate is 1.5 Mbps.**Remark**  $f_{XP}$ : Peripheral clock frequency (prescaler 1 input clock frequency)In clock mode 1,  $f_{XP} = f_{XX}$ In clock mode 2,  $f_{XP} = f_{XMPLL}/2$  (14.64 to 16 MHz)In clock mode 3,  $f_{XP} = f_{XMPLL}$  (29.28 to 32 MHz)In clock mode 4,  $f_{XP} = f_{XMPLL}/2$  (20.88 to 24 MHz) $f_{XX}$ : Main clock frequency $f_{XMPLL}$ : PLL output clock frequency for peripheral clock

k: Settings of UBnCTL2.UBnBRS15 to UBnCTL2.UBnBRS0 bits

ERR: Baud rate error [%]

**(4) Allowable baud rate range during reception**

The degree to which a discrepancy from the transmission destination's baud rate is allowed during reception is shown below.

**Caution** The equations described below should be used to set the baud rate error during reception so that it always is within the allowable error range.

**Figure 16-9. Allowable Baud Rate Range During Reception**

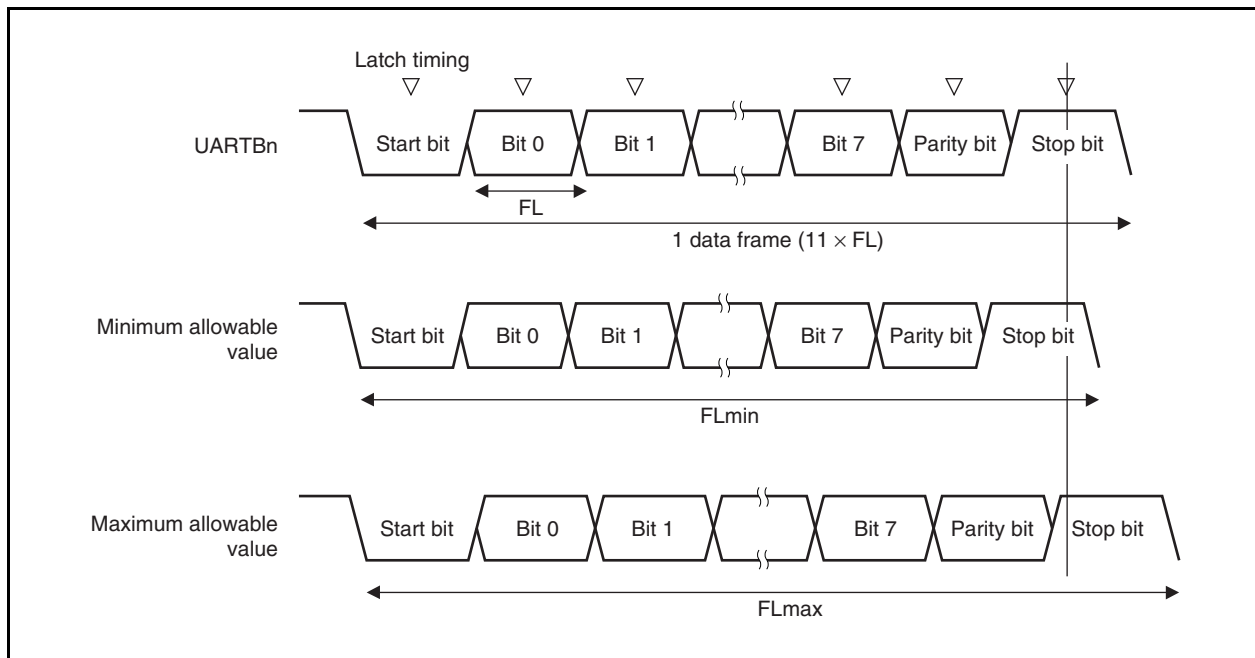

As shown in Figure 16-9, after the start bit is detected, the receive data latch timing is determined according to the counter that was set by the UBnCTL2 register. If all data up to the final data (stop bit) is in time for this latch timing, the data can be received normally.

Applying this to 11-bit reception is, theoretically, as follows.

$$FL = (\text{Brate})^{-1}$$

Brate: UARTBn baud rate

k: UBnCTL2 set value

FL: 1-bit data length

Latch timing margin: 2 clocks

$$\text{Minimum allowable value: } FL_{\min} = 11 \times FL - \frac{k-2}{2k} \times FL = \frac{21k+2}{2k} FL$$



Therefore, the maximum baud rate that can be received at the transfer destination is as follows.

$$BR_{max} = (FL_{min}/11)^{-1} = \frac{22k}{21k + 2} \text{ Brate}$$

Similarly, the maximum allowable value can be obtained as follows.

$$\frac{10}{11} \times FL_{max} = 11 \times FL - \frac{k + 2}{2 \times k} \times FL = \frac{21k - 2}{2 \times k} FL$$

$$FL_{max} = \frac{21k - 2}{20k} FL \times 11$$

Therefore, the minimum baud rate that can be received at the transfer destination is as follows.

$$BR_{min} = (FL_{max}/11)^{-1} = \frac{20k}{21k - 2} \text{ Brate}$$

The allowable baud rate error of UARTBn and the transfer destination can be obtained as follows from the expressions described above for computing the minimum and maximum baud rate values.

**Table 16-6. Maximum and Minimum Allowable Baud Rate Error**

Division Ratio (k)	Maximum Allowable Baud Rate Error	Minimum Allowable Baud Rate Error
4	+2.33 %	-2.44
8	+3.53 %	-3.61
16	+4.14 %	-4.19
32	+4.45 %	-4.48
64	+4.61 %	-4.62
128	+4.68 %	-4.69
256	+4.72 %	-4.73
512	+4.74 %	-4.74
1024	+4.75 %	-4.75
2048	+4.76 %	-4.76
4096	+4.76 %	-4.76
8192	+4.76 %	-4.76
16384	+4.76 %	-4.76
32768	+4.76 %	-4.76
65535	+4.76 %	-4.76

**Remarks 1.** The reception precision depends on the number of bits in one frame, the base clock frequency, and the division ratio (k). The higher the base clock frequency and the larger the division ratio (k), the higher the precision.

**2.** k: UBnCTL2 set value

**(5) Transfer rate during continuous transmission**

During continuous transmission, the transfer rate from a stop bit to the next start bit is extended two clocks longer than normal. However, on the reception side, the transfer result is not affected since the timing is initialized by the detection of the start bit.

**Figure 16-10. Transfer Rate During Continuous Transmission**

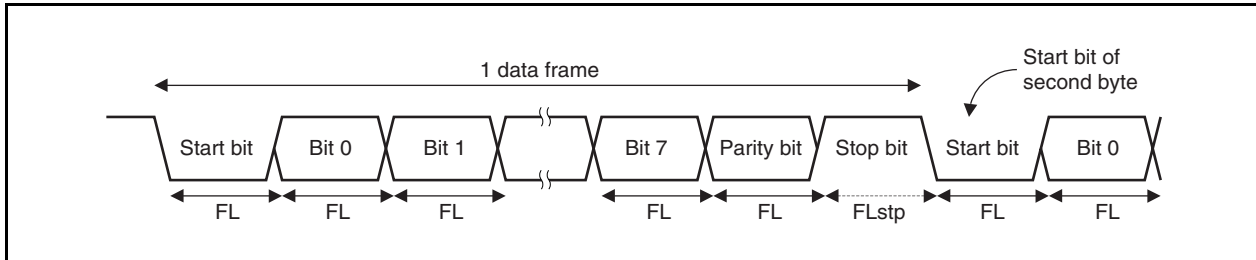

Representing the 1-bit data length by FL, the stop bit length by FLstp, and the base clock frequency by  $f_{XP}$  yields the following equation.

$$FL_{stp} = FL + 2/(f_{XP})$$

Therefore, the transfer rate during continuous transmission is as follows.

$$\text{Transfer rate} = 11 \times FL + 2/(f_{XP})$$

16.8 Control Flow

(1) Example of continuous transmission processing flow in single mode (CPU control)

Figure 16-11. Example of Continuous Transmission Processing Flow in Single Mode (CPU Control)

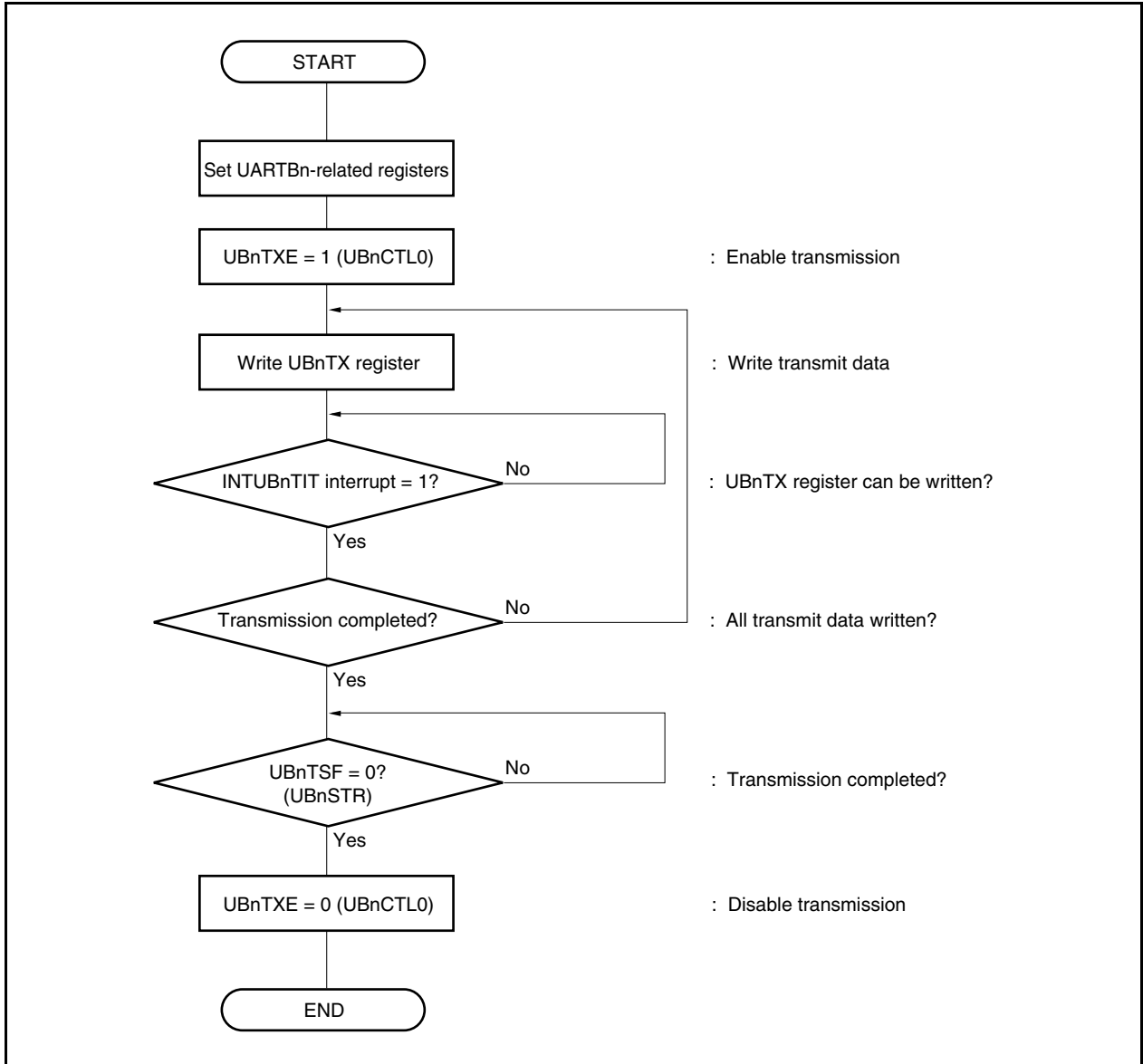

(2) Example of continuous reception processing flow in single mode (CPU control)

Figure 16-12. Example of Continuous Reception Processing Flow in Single Mode (CPU Control)

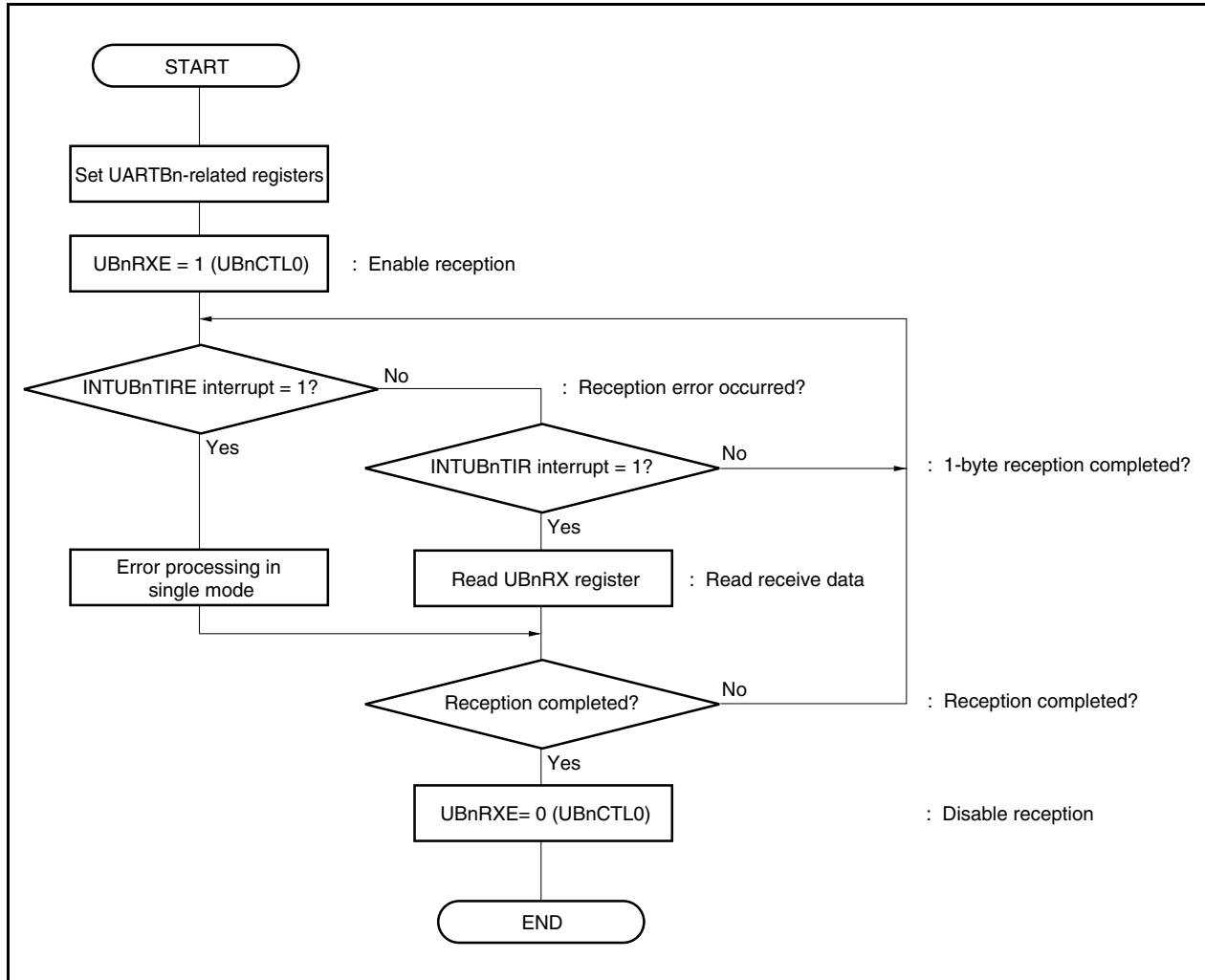

## (3) Example of continuous transmission processing flow in single mode (DMA control)

Figure 16-13. Example of Continuous Transmission Processing Flow in Single Mode (DMA Control)

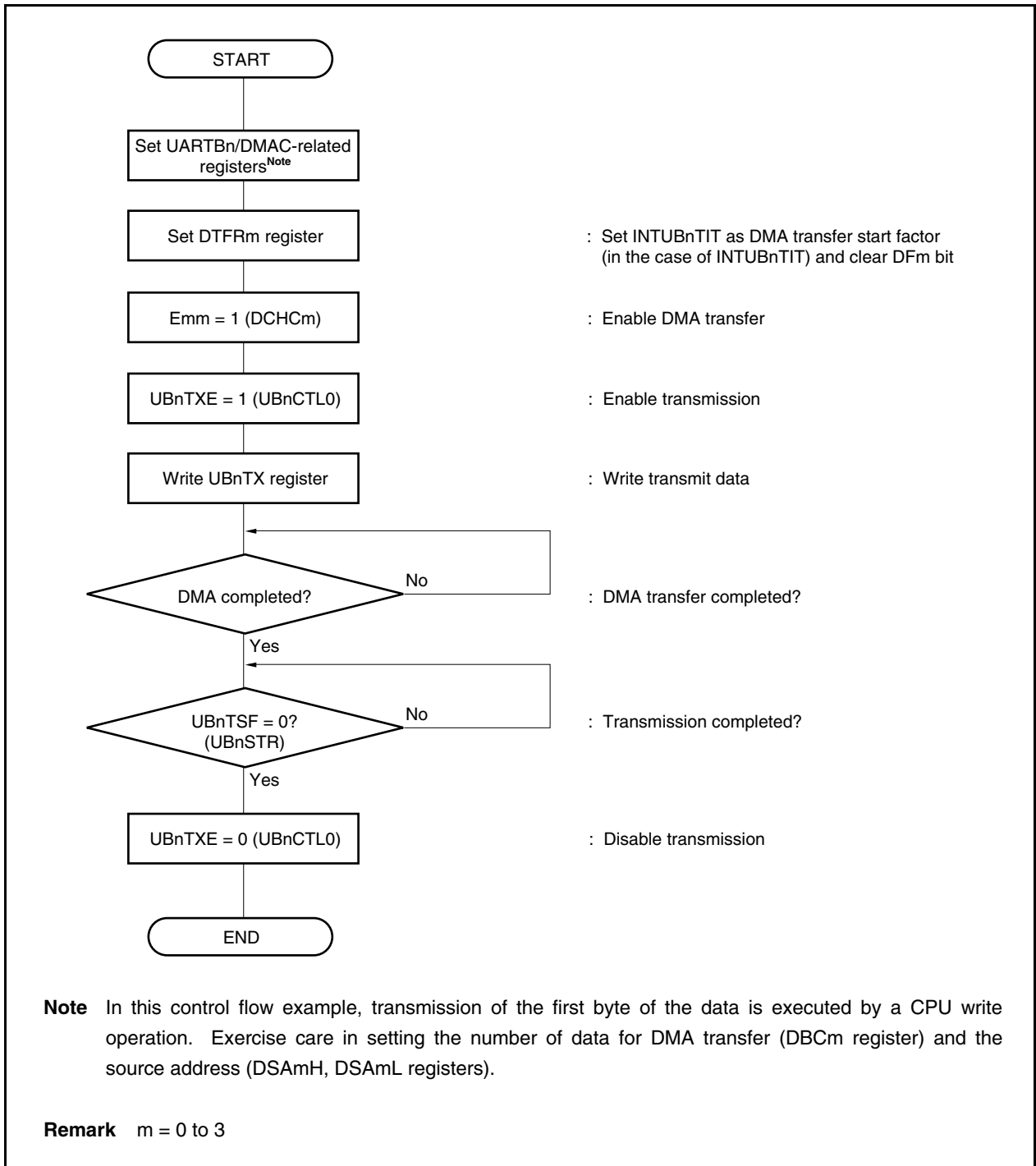

(4) Example of continuous reception processing flow in single mode (DMA control)

Figure 16-14. Example of Continuous Reception Processing Flow in Single Mode (DMA Control)

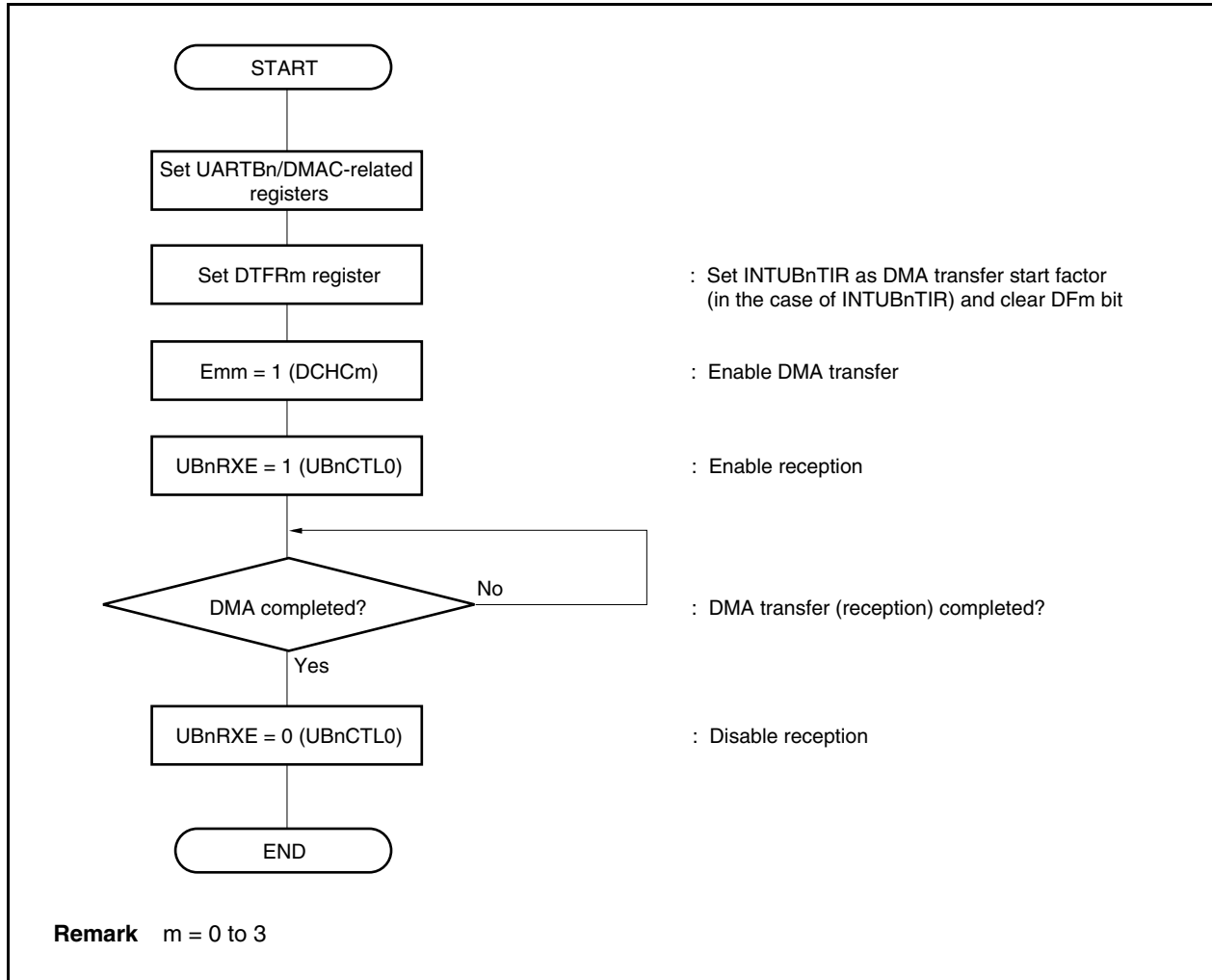

## (5) Example of continuous transmission processing flow in FIFO mode (CPU control)

Figure 16-15. Example of Continuous Transmission Processing Flow in FIFO Mode (CPU Control)

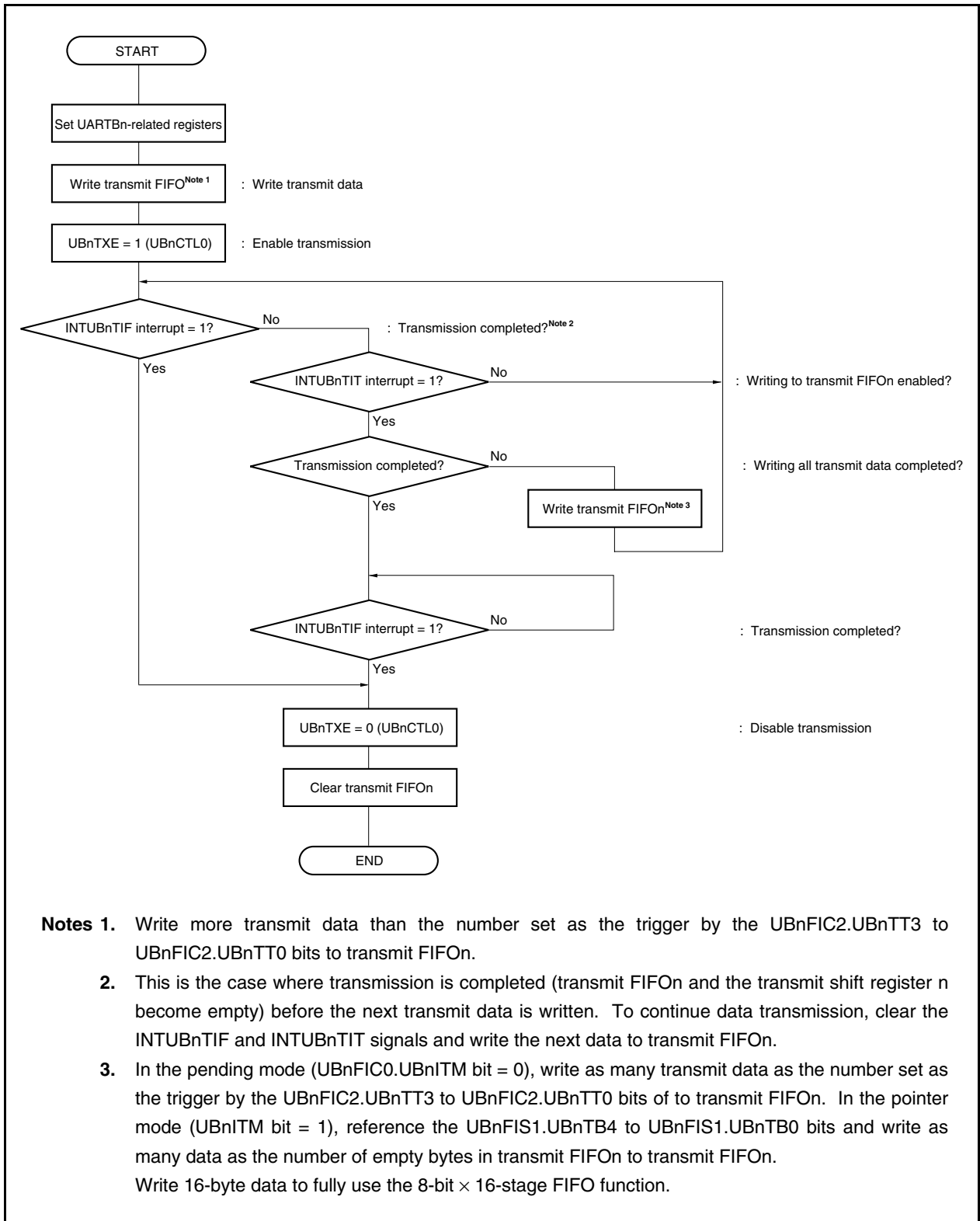

## (6) Example of continuous reception processing in FIFO mode (CPU control)

Figure 16-16. Example of Continuous Reception Processing in FIFO Mode (CPU Control)

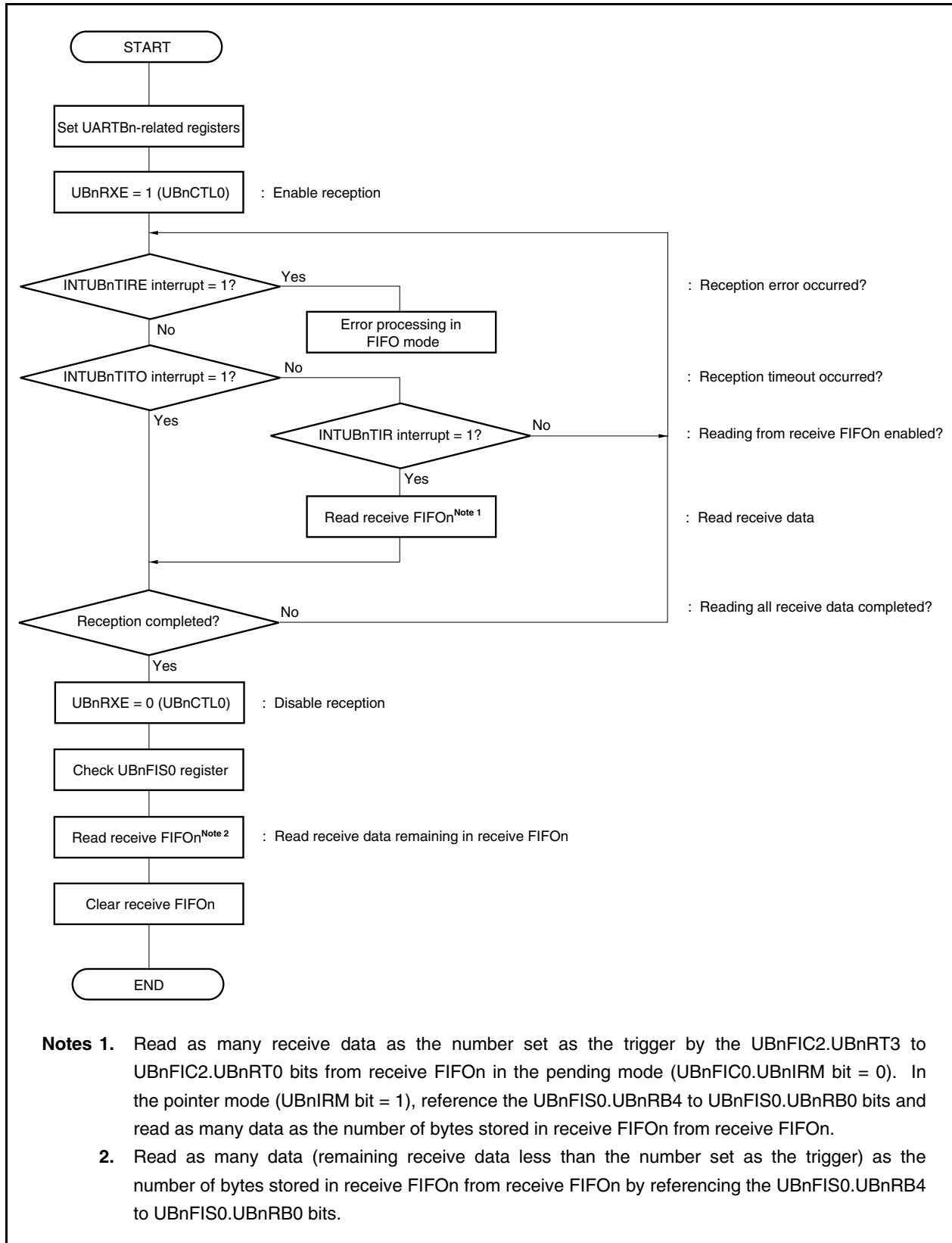

**Notes 1.** Read as many receive data as the number set as the trigger by the UBnFIC2.UBnRT3 to UBnFIC2.UBnRT0 bits from receive FIFO in the pending mode (UBnFIC0.UBnIRM bit = 0). In the pointer mode (UBnIRM bit = 1), reference the UBnFIS0.UBnRB4 to UBnFIS0.UBnRB0 bits and read as many data as the number of bytes stored in receive FIFO from receive FIFO.

**2.** Read as many data (remaining receive data less than the number set as the trigger) as the number of bytes stored in receive FIFO from receive FIFO by referencing the UBnFIS0.UBnRB4 to UBnFIS0.UBnRB0 bits.



## (7) Example of reception error processing in single mode

Figure 16-17. Example of Reception Error Processing Flow in Single Mode

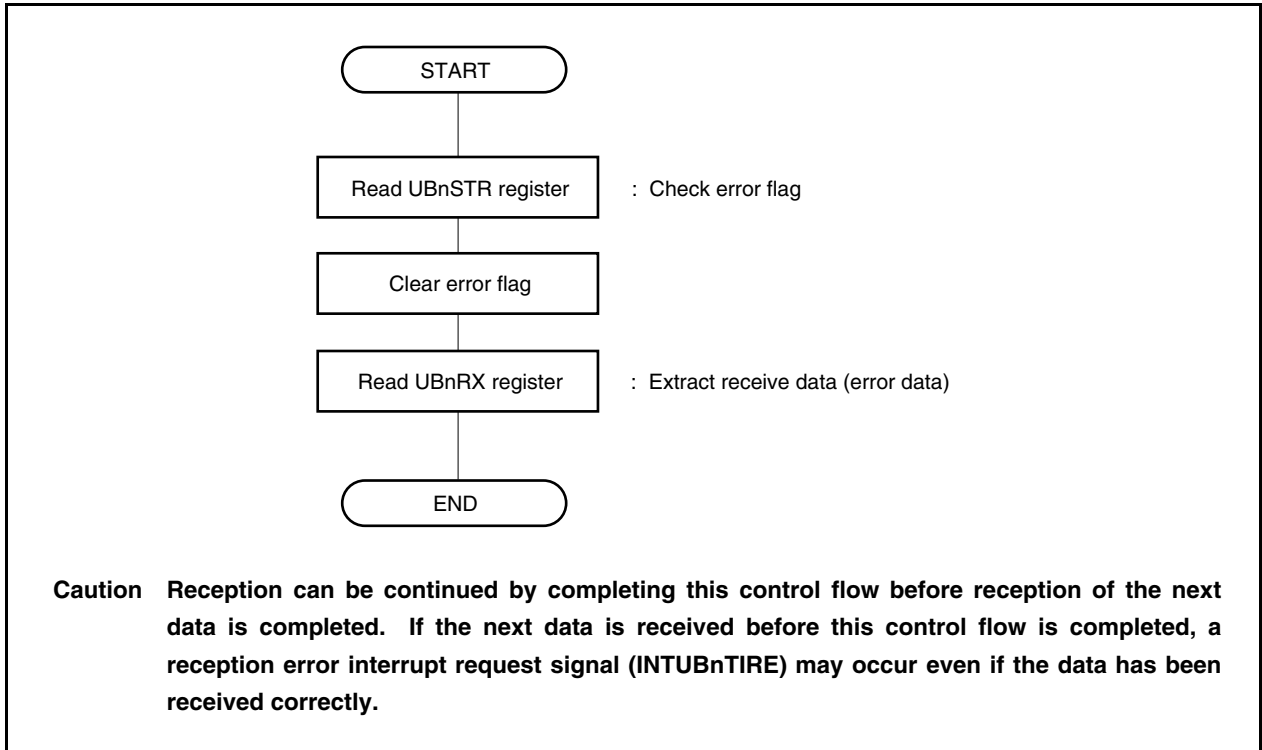

## (8) Example of reception error processing flow in FIFO mode (1)

Figure 16-18. Example of Reception Error Processing Flow in FIFO Mode (1)

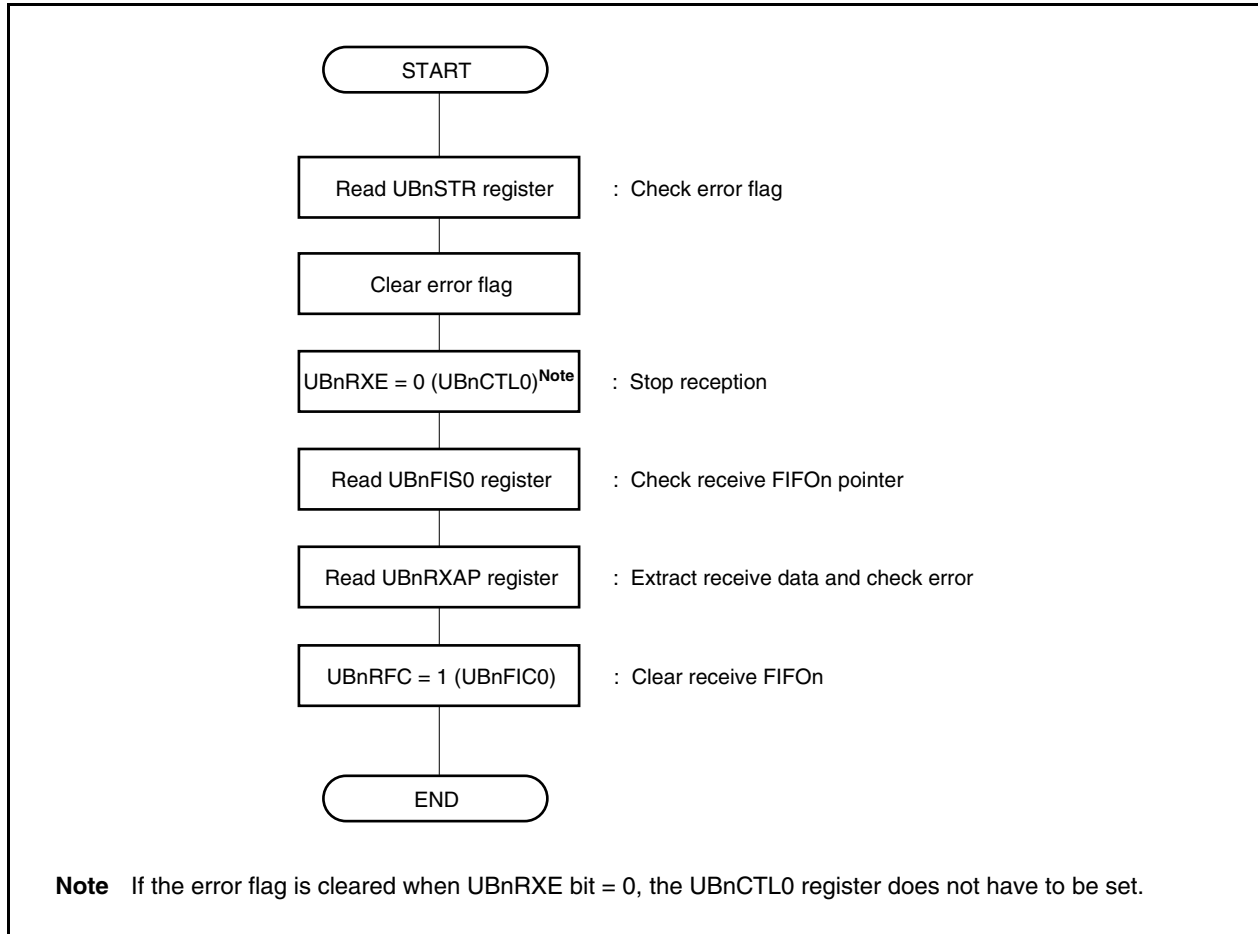

## (9) Example of reception error processing flow in FIFO mode (2)

Figure 16-19. Example of Reception Error Processing Flow in FIFO Mode (2)

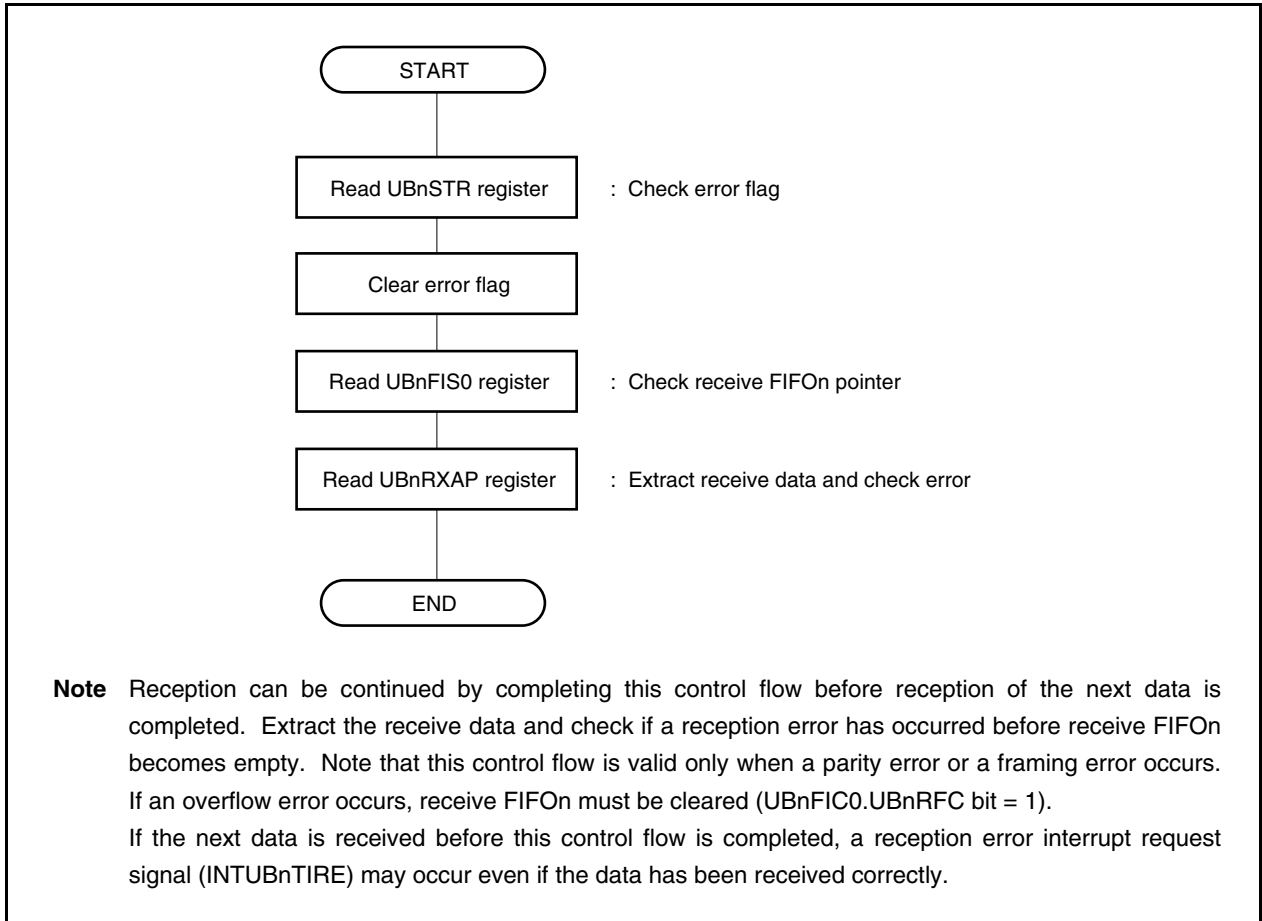

## 16.9 Cautions

Cautions concerning UARTBn are shown below.

### (1) When using DMA control

Be sure to select the single mode when writing a transmit data or reading a received data by using the DMA control. In FIFO mode, the use of the DMA control is prohibited.

### (2) When supply clock to UARTBn is stopped

When the supply of clocks to UARTBn is stopped (for example, IDLE and STOP modes), operation stops with each register retaining the value it had immediately before the supply of clocks was stopped. The TXDBn pin output also holds and outputs the value it had immediately before the supply of clocks was stopped. However, operation is not guaranteed after the supply of clocks is restarted. Therefore, after the supply of clocks is restarted, the circuits should be initialized by setting the UBnPWR bit = 0, UBnRXE bit = 0, and UBnTXE bit = 0.

### (3) Caution on setting UBnCTL0 register

- When using UARTBn, set the external pins related to the UARTBn function to the alternate function and set the UBnCTL2 register. Then set the UBnCTL0.UBnPWR bit to 1 before setting the other bits.
- Be sure to input a high level to the RXDBn pin when setting the external pins related to the UARTBn function to the alternate function. If a low level is input, it is judged that a falling edge is input after the UBnCTL0.UBnRXE bit has been set to 1, and reception may be started.

### (4) Caution on setting UBnFIC2 register

Be sure to clear the UBnCTL0.UBnTXE bit (to disable transmission) and UBnCTL0.UBnRXE bit (to disable reception) to 0 before writing data to the UBnFIC2 register. If data is written to the UBnFIC2 register with the UBnTXE or UBnRXE bit set to 1, the operation is not guaranteed.

### (5) Transmission interrupt request signal

In the single mode, the transmission enable interrupt request signal (INTUBnTIT) occurs when the UBnTX register becomes empty (when 1 byte of data is transferred from the UBnTX register to the transmit shift register). In the FIFO mode, the FIFO transmission completion interrupt request signal (INTUBnTIF) occurs when data is no longer in transmit FIFO and the transmit shift register n (when the FIFO and register are empty). However, the INTUBnTIT signal or INTUBnTIF signal does not occur if the transmit data register becomes empty due to  $\overline{\text{RESET}}$  input.

### (6) Initialization during continuous transmission in single mode

Confirm that the UBnSTR.UBnTSF bit is 0 before executing initialization during transmission processing. If initialization is executed while the UBnTSF bit is 1, the transmit data is not guaranteed.

### (7) Initialization during continuous transmission (pending mode) in FIFO mode

Confirm that the UBnSTR.UBnTSF bit is 0 before executing initialization during transmission processing (this can also be done by checking the FIFO transmission completion interrupt request signal (INTUBnTIF)). If initialization is executed while the UBnTSF bit is 1, the transmit data is not guaranteed.

**(8) Initialization during continuous transmission (pointer mode) in FIFO mode**

Confirm that the UBnSTR.UBnTSF bit is 0 before executing initialization during transmission processing (this can also be done by checking the FIFO transmission completion interrupt request signal (INTUBnTIF)). If initialization is executed while the UBnTSF bit is 1, the transmit data is not guaranteed.

**(9) Receive operation in FIFO mode (pointer mode specified)**

If the pointer mode is specified in the FIFO mode and if as many data as the number of bytes stored in receive FIFO<sub>n</sub> are read by referencing the UBnFIS0 register, no data may be stored in receive FIFO<sub>n</sub> (UBnFIS0.UBnRB4 to UBnFIS0.UBnRB0 bits = 00000) even though the reception completion interrupt request signal (INTUBnTIR) has occurred. In this case, do not read data from receive FIFO<sub>n</sub>. Be sure to read data from receive FIFO<sub>n</sub> after confirming that the number of bytes stored in receive FIFO<sub>n</sub> = 1 byte or more (UBnRB4 to UBnRB0 bits = other than 00000).

**(10) Switching DMA transfer start factor**

In the V850E/SJ3-H and V850E/SK3-H, the INTUB0TIR and INTTQ0OV signals, INTUB0TIT and INTTP0OV signals, INTUB1TIR and INTTP1OV signals, and INTUB1TIT and INTTP2OV signals, which are the DMA transfer start factors, share the same pin, respectively, and they cannot be used at the same time. To use the INTUB0TIR, INTUB0TIT, INTUB1TIR, or INTUB1TIT signal as the DMA transfer start factor, set the option byte (0000007AH) (see **CHAPTER 33 OPTION BYTE FUNCTION**) DTFROB0 bit = 1. In this case, the INTTQ0OV, INTTP0OV, INTTP1OV, and INTTP2OV signals cannot be used as the DMA transfer start factor.

**Remark** For details, see **Table 22-1 DMA Transfer Start Factors**.

## CHAPTER 17 3-WIRE VARIABLE-LENGTH SERIAL I/O B (CSIB)

### 17.1 Port Settings of CSIB0 to CSIB5

#### 17.1.1 For V850E/SJ3-H

**Table 17-1. Pin Configuration**

Mode	Pin Name	Alternate-Function Pin					
		Port <1>			Port <2>		
		Pin No.	Port	Alternate Function	Pin No.	Port	Alternate Function
CSIB0	SIB0	22	P40	SDA01	–	–	–
	SOB0	23	P41	SCL01	–	–	–
	$\overline{\text{SCKB0}}$	24	P42	INTP2	–	–	–
CSIB1	SIB1	68	P97	A7/TIP20/TOP20	–	–	–
	SOB1	69	P98	A8	–	–	–
	$\overline{\text{SCKB1}}$	70	P99	A9	–	–	–
CSIB2	SIB2	40	P53	KR3/TIQ00/TOQ00/RTP03/DDO	35	P38	TXDA2/SDA00
	SOB2	41	P54	KR4/RTP04/DCK	–	–	–
	$\overline{\text{SCKB2}}$	42	P55	KR5/RTP05/DMS	36	P39	RXDA2/SCL00
CSIB3	SIB3	71	P910	A10	–	–	–
	SOB3	72	P911	A11	–	–	–
	$\overline{\text{SCKB3}}$	73	P912	A12	–	–	–
CSIB4	SIB4	26	P31	RXDA0/INTP7	–	–	–
	SOB4	25	P30	TXDA0	–	–	–
	$\overline{\text{SCKB4}}$	27	P32	ASCKA0/TIP00/TOP00	–	–	–
CSIB5	SIB5	49	P66	INTP9/KR3/TIQ00/TOQ00	–	–	–
	SOB5	50	P67	RXDA5/SDA05 <sup>Note</sup>	–	–	–
	$\overline{\text{SCKB5}}$	51	P68	TXDA5/SCL05 <sup>Note</sup>	–	–	–

<R>

<R>

<R> **Note** These pins are not included in the  $\mu$ PD70F3931, 70F3932, and 70F3933.

#### (1) CSIB0

The serial reception data/serial transmission data/serial clock pins (SIB0, SOB0, and  $\overline{\text{SCKB0}}$ ) of CSIB0 are assigned to P40, P41, and P42, respectively. When using CSIB0, specify P40, P41, and P42 as the SIB0, SOB0, and  $\overline{\text{SCKB0}}$  pins in advance, using the PMC4 and PFC4 registers.

The SIB0, SOB0, and  $\overline{\text{SCKB0}}$  pins and the serial transmission/reception data/serial clock pins (SDA01 and SCL01) of I<sup>2</sup>C01 are alternate functions of the same pin, and therefore cannot be used simultaneously. In addition, the  $\overline{\text{SCKB0}}$  pin also functions alternately as the INTP2 pin (external interrupt input), so use the INTP2 pin assigned to another port pin (P05) when using the  $\overline{\text{SCKB0}}$  and INTP2 pins simultaneously.

#### (2) CSIB1

The serial reception data, serial transmission data, and serial clock pins (SIB1, SOB1, and  $\overline{\text{SCKB1}}$ ) of CSIB1 are assigned to P97, P98, and P99, respectively. When using CSIB1, specify P97, P98, and P99 as the SIB1, SOB1, and  $\overline{\text{SCKB1}}$  pins in advance, using the PMC9, PFC9 and PFCE9 registers.

The SIB1, SOB1, and  $\overline{\text{SCKB1}}$  pins, TMP2 I/O pins (TIP20/TOP20), and address bus pins (A7 to A9) are alternate functions of the same pins, and therefore cannot be used simultaneously.

### (3) CSIB2

The serial reception data, serial transmission data, and serial clock pins (SIB2, SOB2, and  $\overline{\text{SCKB2}}$ ) of CSIB2 are assigned to P53, P54, and P55, respectively. In addition, the SIB2 and  $\overline{\text{SCKB2}}$  pins are also assigned to P38 and P39, respectively, and can only be used at either one of the pins (if used at P38 and P39, it is for reception only). When using CSIB2 at P53, P54, and P55, specify P53, P54, and P55 as the SIB2, SOB2, and  $\overline{\text{SCKB2}}$  pins in advance, using the PMC5, PFC5 and PFCE5 registers. When using CSIB2 at P38 and P39 for reception only, specify P38 and P39 as the SIB2 and  $\overline{\text{SCKB2}}$  pins in advance, using the PMC3, PFC3, and PFCE3 registers.

P53, P54, and P55 function as the on-chip debug control pins (DDO, DCK, and DMS) and the I/O pins (TIQ00 and TOQ00) of TMQ0. By using CSIB2 at P38 and P39 for reception only, these alternate functions can be used simultaneously with CSIB2. P38 and P39 function as the UARTA2 transmission/reception pins (TXDA2 and RXDA2) and the serial transmission/reception data/serial clock pins (SDA00 and SCL00) of I<sup>2</sup>C00. By using CSIB2 at P53, P54, and P55, these alternate functions can be used simultaneously with CSIB2.

### (4) CSIB3

The serial reception data, serial transmission data, and serial clock pins (SIB3, SOB3, and  $\overline{\text{SCKB3}}$ ) of CSIB3 are assigned to P910, P911, and P912, respectively. When using CSIB3, specify P910, P911, and P912 as the SIB3, SOB3, and  $\overline{\text{SCKB3}}$  pins in advance, using the PMC9 and PFC9 registers.

The SIB3, SOB3, and  $\overline{\text{SCKB3}}$  pins and the address bus pins (A10 to A12) are alternate functions of the same pin, and therefore cannot be used simultaneously.

### (5) CSIB4

The serial reception data/serial transmission data/serial clock pins (SIB4, SOB4, and  $\overline{\text{SCKB4}}$ ) of CSIB4 are assigned to P31, P30, and P32, respectively. When using CSIB4, specify P31, P30, and P32 as the SIB4, SOB4, and  $\overline{\text{SCKB4}}$  pins in advance, using the PMC3, PFC3 and PFCE3 registers.

The SIB4 and SOB4 pins and the transmission/reception pins (RXDA0 and TXDA0) of UARTA0 are alternate functions of the same pin, and therefore cannot be used simultaneously. In addition, the SIB4 pin also functions alternately as the INTP7 pin (external interrupt input), so use the INTP7 pin assigned to another port pin (P51) when using the SIB4 and INTP7 pins simultaneously.

### (6) CSIB5

The serial reception data/serial transmission data/serial clock pins (SIB5, SOB5, and  $\overline{\text{SCKB5}}$ ) of CSIB5 are assigned to P66, P67, and P68, respectively. When using CSIB5, specify P66, P67, and P68 as the SIB5, SOB5, and  $\overline{\text{SCKB5}}$  pins in advance, using the PMC6, PFC6, and PFCE6 registers.

The SOB5 and  $\overline{\text{SCKB5}}$  pins, the transmission/reception pins (RXDA5 and TXDA5) of UARTA5, and the serial transmission/reception data/serial clock pins (SDA05 and SCL05)<sup>Note</sup> of I<sup>2</sup>C05 are alternate functions of the same pin, respectively, and therefore cannot be used simultaneously.

<R>

<R>

**Note** These pins are not included in the  $\mu$ PD70F3931, 70F3932, and 70F3933

**Caution** Do not switch port settings during operation. Also, be sure to disable operation of unused units for which port settings are not made.

## 17.1.2 For V850E/SK3-H

Table 17-2. Pin Configuration

Mode	Pin Name	Alternate-Function Pin					
		Port <1>			Port <2>		
		Pin No.	Port	Alternate Function	Pin No.	Port	Alternate Function
CSIB0	SIB0	24	P40	SDA01	–	–	–
	SOB0	25	P41	SCL01	–	–	–
	$\overline{\text{SCKB0}}$	26	P42	INTP2	–	–	–
CSIB1	SIB1	84	P97	A7/TIP20/TOP20	–	–	–
	SOB1	85	P98	A8	–	–	–
	$\overline{\text{SCKB1}}$	86	P99	A9	–	–	–
CSIB2	SIB2	48	P53	KR3/TIQ00/TOQ00/RTP03/DDO	40	P38	TXDA2/SDA00
	SOB2	49	P54	KR4/RTP04/DCK	42	P310	–
	$\overline{\text{SCKB2}}$	50	P55	KR5/RTP05/DMS	41	P39	RXDA2/SCL00
CSIB3	SIB3	87	P910	A10	–	–	–
	SOB3	88	P911	A11	–	–	–
	$\overline{\text{SCKB3}}$	89	P912	A12	–	–	–
CSIB4	SIB4	31	P31	RXDA0/INTP7	–	–	–
	SOB4	30	P30	TXDA0	–	–	–
	$\overline{\text{SCKB4}}$	32	P32	ASCKA0/TIP00/TOP00	–	–	–
CSIB5	SIB5	59	P66	INTP9/KR3/TIQ00/TOQ00	–	–	–
	SOB5	60	P67	RXDA5/SDA05	–	–	–
	$\overline{\text{SCKB5}}$	61	P68	TXDA5/SCL05	–	–	–

**(1) CSIB0**

The serial reception data/serial transmission data/serial clock pins (SIB0, SOB0, and  $\overline{\text{SCKB0}}$ ) of CSIB0 are assigned to P40, P41, and P42, respectively. When using CSIB0, specify P40, P41, and P42 as the SIB0, SOB0, and  $\overline{\text{SCKB0}}$  pins in advance, using the PMC4 and PFC4 registers.

The SIB0 and  $\overline{\text{SCKB0}}$  pins and the serial transmission/reception data/serial clock pins (SDA01 and SCL01) of  $\text{I}^2\text{C01}$  are alternate functions of the same pin, and therefore cannot be used simultaneously. In addition, the  $\overline{\text{SCKB0}}$  pin also functions alternately as the INTP2 pin (external interrupt input), so use the INTP2 pin assigned to another port pin (P05) when using the  $\overline{\text{SCKB0}}$  and INTP2 pins simultaneously.

**(2) CSIB1**

The serial reception data, serial transmission data, and serial clock pins (SIB1, SOB1, and  $\overline{\text{SCKB1}}$ ) of CSIB1 are assigned to P97, P98, and P99, respectively. When using CSIB1, specify P97, P98, and P99 as the SIB1, SOB1, and  $\overline{\text{SCKB1}}$  pins in advance, using the PMC9, PFC9, and PFCE9 registers.

The SIB1, SOB1, and  $\overline{\text{SCKB1}}$  pins, the TMP2 I/O pins (TIP20/TOP20), and the address bus pins (A7 to A9) are alternate functions of the same pins, and therefore cannot be used simultaneously.



**(3) CSIB2**

The serial reception data, serial transmission data, and serial clock pins (SIB2, SOB2, and  $\overline{\text{SCKB2}}$ ) of CSIB2 are assigned to P53, P54, and P55, respectively. In addition, the SIB2, SOB2, and  $\overline{\text{SCKB2}}$  pins are assigned to P38, P310, and P39, respectively, and can be used at either one of the pins only.

When using CSIB1 at P53, P54, and P55, specify P53, P54, and P55 as the SIB2, SOB2, and  $\overline{\text{SCKB2}}$  pins in advance, using the PMC5, PFC5 and PFCE5 registers. When using CSIB2 at P38, P310, and P39, specify P38, P310, and P39 as the SIB2, SOB2, and  $\overline{\text{SCKB2}}$  pins in advance, using the PMC3, PFC3, and PFCE3 registers.

P53, P54, and P55 function as the on-chip debug control pins (DDO, DCK, and DMS) and the I/O pins (TIQ00 and TOQ00) of TMQ0. By using CSIB2 at P38, P310, and P39, these alternate functions can be used simultaneously with CSIB2. P38 and P39 function as the serial transmission/reception data/serial clock pins (SDA00 and SCL00) of I<sup>2</sup>C00, and therefore cannot be used simultaneously. In addition, P38 and P39 also function as UARTA2 transmission/reception pins (TXDA2 and RXDA2). Use the TXDA2 and RXDA2 pins assigned to another port pin (P311 and P312) when using these pins and other alternate functions simultaneously.

**(4) CSIB3**

The serial reception data, serial transmission data, and serial clock pins (SIB3, SOB3, and  $\overline{\text{SCKB3}}$ ) of CSIB3 are assigned to P910, P911, and P912, respectively. When using CSIB3, specify P910, P911, and P912 as the SIB3, SOB3, and  $\overline{\text{SCKB3}}$  pins in advance, using the PMC9 and PFC9 registers.

The SIB3, SOB3, and  $\overline{\text{SCKB3}}$  pins and the address bus pins (A10 to A12) are alternate functions of the same pin, and therefore cannot be used simultaneously.

**(5) CSIB4**

The serial reception data/serial transmission data/serial clock pins (SIB4, SOB4, and  $\overline{\text{SCKB4}}$ ) of CSIB4 are assigned to P31, P30, and P32, respectively. When using CSIB4, specify P31, P30, and P32 as the SIB4, SOB4, and  $\overline{\text{SCKB4}}$  pins in advance, using the PMC3, PFC3 and PFCE3 registers.

The SIB4 and SOB4 pins and the transmission/reception pins (RXDA0 and TXDA0) of UARTA0 are alternate functions of the same pin, and therefore cannot be used simultaneously. In addition, the SIB4 pin also functions alternately as the INTP7 pin (external interrupt input), so use the INTP7 pin assigned to another port pin (P51) when using the SIB4 and INTP7 pins simultaneously.

**(6) CSIB5**

The serial reception data/serial transmission data/serial clock pins (SIB5, SOB5, and  $\overline{\text{SCKB5}}$ ) of CSIB5 are assigned to P66, P67, and P68, respectively. When using CSIB5, specify P66, P67, and P68 as the SIB5, SOB5, and  $\overline{\text{SCKB5}}$  pins in advance, using the PMC6, PFC6, and PFCE6 registers.

The SOB5 and  $\overline{\text{SCKB5}}$  pins, the transmission/reception pins (RXDA5 and TXDA5) of UARTA5, and the serial transmission/reception data/serial clock pins (SDA05 and SCL05) of I<sup>2</sup>C05 are alternate functions of the same pin, so use the RXDA5 and TXDA5 pins and SDA05 and SCL05 pins assigned to another port pin (UARTA5: P84 and P85, I<sup>2</sup>C05: P82 and P83) when using these pins and other alternate functions simultaneously.

**Caution Do not switch port settings during operation. Also, be sure to disable operation of unused units for which port settings are not made.**

## 17.2 Features

- Transfer rate: 8 Mbps max.
- Master mode and slave mode selectable
- Transfer data length selectable in 1-bit units between 8 and 16 bits
- Transfer data MSB-first/LSB-first switchable
- Serial clock and data phase switchable
- Transmission mode, reception mode, transmission/reception mode specifiable
  - Transmission mode: Transmission starts triggered by writing a transmit data to the CSIBn transmit data register (CBnTX) in the transmission enabled state.
  - Reception mode: Reception starts triggered by reading the CSIBn receive data register (CBnRX) in the reception enabled state.
  - Transmission/reception mode: Transmission/reception starts triggered by writing a transmit data to the CSIBn transmit data register (CBnTX) in the transmission/reception enabled state.
- Interrupt request signal
  - Reception completion interrupt (INTCBnR)
  - Transmission enable interrupt (INTCBnT)
- 3-wire transfer
  - SOBn: Serial data output
  - SIBn: Serial data input
  - $\overline{\text{SCKBn}}$ : Serial clock I/O

**Remark** n = 0 to 5

## 17.3 Configuration

The following shows the block diagram of CSIBn.

Figure 17-1. Block Diagram of CSIBn

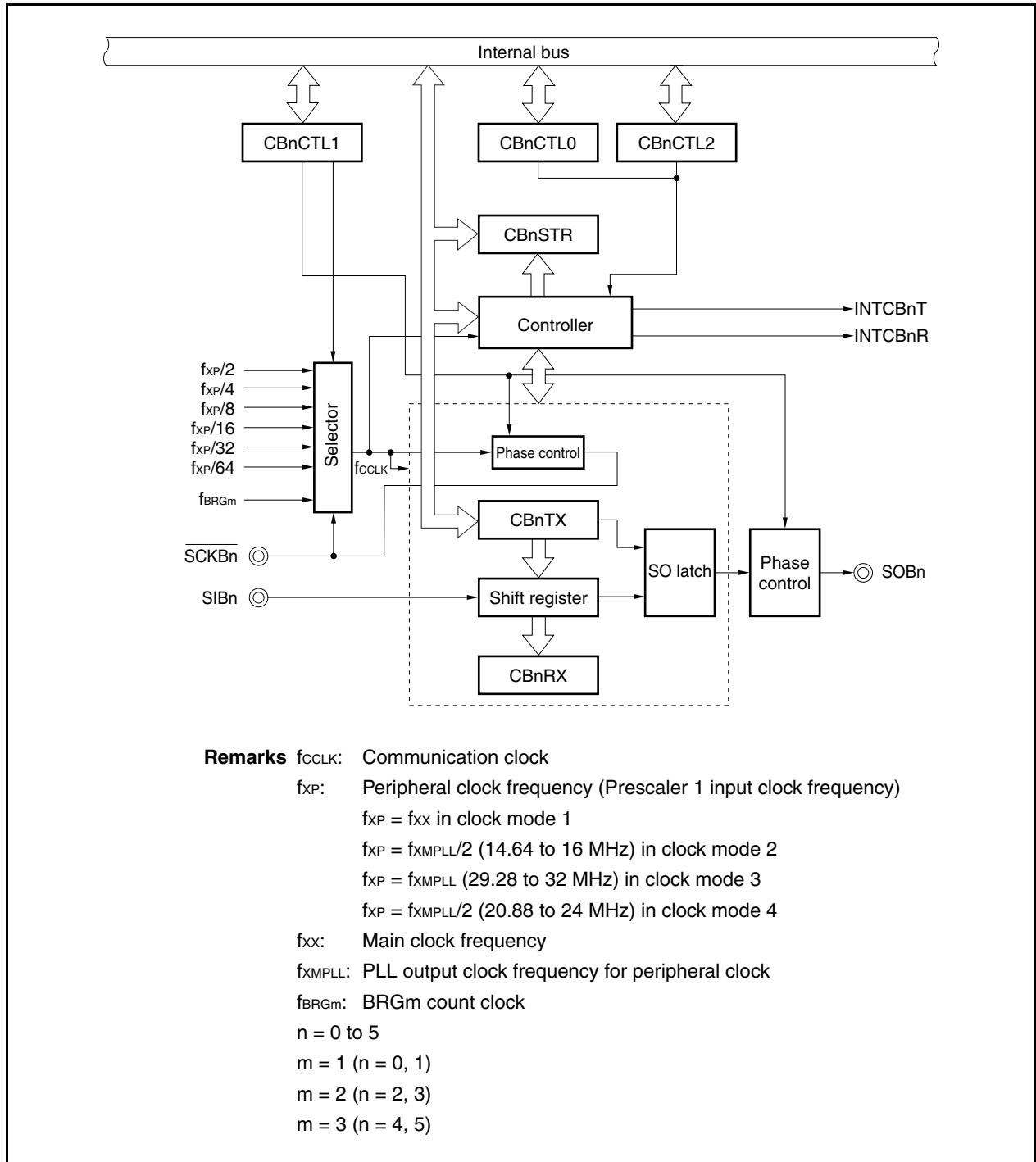

CSIBn includes the following hardware.

**Table 17-3. Configuration of CSIBn**

Item	Configuration
Registers	CSIBn receive data register (CBnRX) CSIBn transmit data register (CBnTX)
Control registers	CSIBn control register 0 (CBnCTL0) CSIBn control register 1 (CBnCTL1) CSIBn control register 2 (CBnCTL2) CSIBn status register (CBnSTR)

**(1) CSIBn receive data register (CBnRX)**

The CBnRX register is a 16-bit buffer register that holds receive data.

This register is read-only, in 16-bit units.

The receive operation is started by reading the CBnRX register in the reception enabled status.

If the transfer data length is 8 bits, the lower 8 bits of this register are read-only in 8-bit units as the CBnRXL register.

Reset sets this register to 0000H.

In addition to reset input, the CBnRX register can be initialized by clearing (to 0) the CBnPWR bit of the CBnCTL0 register.

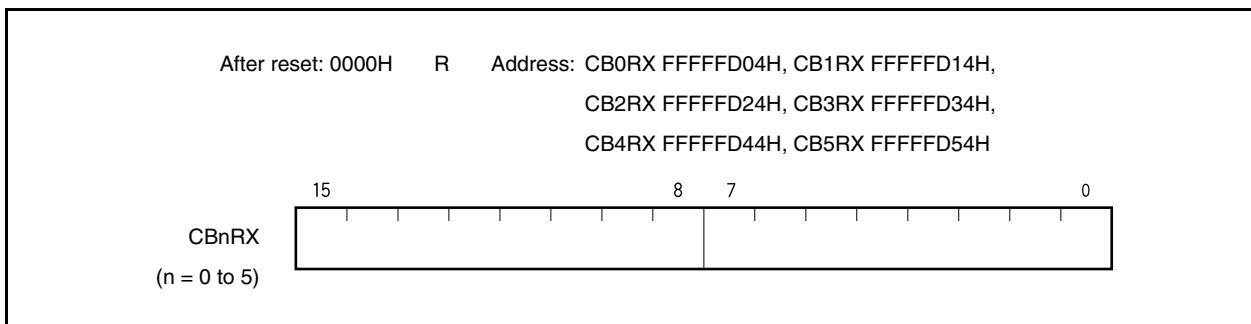

**(2) CSIBn transmit data register (CBnTX)**

The CBnTX register is a 16-bit buffer register used to write the CSIBn transfer data.

This register can be read or written in 16-bit units.

The transmit operation is started by writing data to the CBnTX register in the transmission enabled status.

If the transfer data length is 8 bits, the lower 8 bits of this register are read or written in 8-bit units as the CBnTXL register.

Reset sets this register to 0000H.

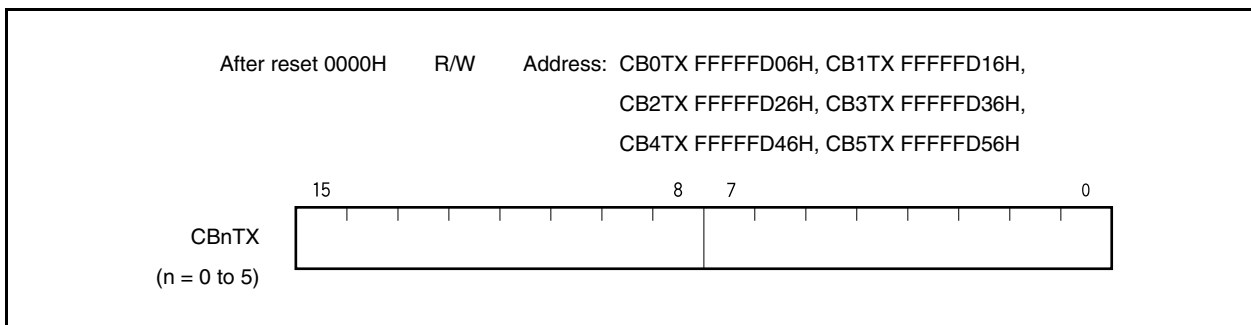

**Remark** The communication start conditions are shown below.

- |   |                          |
|---|--------------------------|
| Transmission mode (CBnTXE bit = 1, CBnRXE bit = 0):           | Write to CBnTX register  |
| Transmission/reception mode (CBnTXE bit = 1, CBnRXE bit = 1): | Write to CBnTX register  |
| Reception mode (CBnTXE bit = 0, CBnRXE bit = 1):              | Read from CBnRX register |

## 17.4 Registers

The following registers are used to control CSIBn.

- CSIBn control register 0 (CBnCTL0)
- CSIBn control register 1 (CBnCTL1)
- CSIBn control register 2 (CBnCTL2)
- CSIBn status register (CBnSTR)

### (1) CSIBn control register 0 (CBnCTL0)

CBnCTL0 is a register that controls the CSIBn serial transfer operation.

This register can be read or written in 8-bit or 1-bit units.

Reset sets this register to 01H.

(1/3)

After reset: 01H    R/W    Address: CB0CTL0 FFFFFFFD00H, CB1CTL0 FFFFFFFD10H,  
CB2CTL0 FFFFFFFD20H, CB3CTL0 FFFFFFFD30H,  
CB4CTL0 FFFFFFFD40H, CB5CTL0 FFFFFFFD50H

	<7>	<6>	<5>	<4>	3	2	1	<0>
CBnCTL0 (n = 0 to 5)	CBnPWR	CBnTXE <sup>Note</sup>	CBnRXE <sup>Note</sup>	CBnDIR <sup>Note</sup>	0	0	CBnTMS <sup>Note</sup>	CBnSCE

CBnPWR	Specification of CSIBn operation disable/enable
0	Disable CSIBn operation and reset the CBnSTR register
1	Enable CSIBn operation
• The CBnPWR bit controls the CSIBn operation and resets the internal circuit.	

CBnTXE <sup>Note</sup>	Specification of transmit operation disable/enable
0	Disable transmit operation
1	Enable transmit operation
• The SOBn output is low level when the CBnTXE bit is 0.	

CBnRXE <sup>Note</sup>	Specification of receive operation disable/enable
0	Disable receive operation
1	Enable receive operation
• When the CBnRXE bit is cleared to 0, no reception completion interrupt is output even when the prescribed data is transferred in order to disable the receive operation, and the receive data (CBnRX register) is not updated.	

**Note** These bits can only be rewritten when the CBnPWR bit = 0. However, CBnPWR bit = 1 can also be set at the same time as rewriting these bits.

**Cautions 1. To forcibly suspend transmission/reception, clear the CBnPWR bit instead of the CBnTXE and CBnRXE bits to 0. At this time, the clock output is stopped.**

**2. Be sure to set bits 3 and 2 to “0”.**

CBnDIR <sup>Note</sup>	Specification of transfer direction mode (MSB/LSB)
0	MSB-first transfer
1	LSB-first transfer

CBnTMS <sup>Note</sup>	Transfer mode specification
0	Single transfer mode
1	Continuous transfer mode

[In single transfer mode]

The reception completion interrupt request signal (INTCBnR) is generated.

Even if transmission is enabled (CBnTXE bit = 1), the transmission enable interrupt request signal (INTCBnT) is not generated.

If the next transmit data is written during communication (CBnSTR.CBnTSF bit = 1), it is ignored and the next communication is not started. Also, if reception-only communication is set (CBnTXE bit = 0, CBnRXE bit = 1), the next communication is not started even if the receive data is read during communication (CBnSTR.CBbTSF bit = 1).

[In continuous transfer mode]

The continuous transmission is enabled by writing the next transmit data during communication (CBnSTR.CBnTSF bit = 1). Writing the next transmission data is enabled after a transmission enable interrupt (INTCBnT) occurrence.

If reception-only communication is set (CBnTXE bit = 0, CBnRXE bit = 1) in the continuous transfer mode, the next reception is started continuously after a reception completion interrupt (INTCBnR) regardless of the read operation of the CBnRX register.

Therefore, read immediately the receive data from the CBnRX register. If this read operation is delayed, an overrun error (CBnOVE bit = 1) occurs.

**Note** These bits can only be rewritten when the CBnPWR bit = 0.  
However, CBnPWR bit = 1 can also be set at the same time as rewriting these bits.

CBnSCE	Specification of start transfer disable/enable
0	Communication start trigger invalid
1	Communication start trigger valid

- In master mode  
This bit enables or disables the communication start trigger.
  - (a) In single transmission or transmission/reception mode, or continuous transmission or continuous transmission/reception mode  
The setting of the CBnSCE bit has no influence on communication operation.
  - (b) In single reception mode  
Clear the CBnSCE bit to 0 before reading the last receive data because reception is started by reading the receive data (CBnRX register) to disable the reception startup<sup>Note 1</sup>.
  - (c) In continuous reception mode  
Clear the CBnSCE bit to 0 one communication clock before reception of the last data is completed to disable the reception startup after the last data is received<sup>Note 2</sup>.
- In slave mode  
This bit enables or disables the communication start trigger.  
Set the CBnSCE bit to 1<sup>Note 3</sup>.

- Notes**
1. If the CBnSCE bit is read while it is 1, the next communication operation is started.
  2. The CBnSCE bit is not cleared to 0 one communication clock before the completion of the last data reception, the next communication operation is automatically started.  
To start the communication operation again after the last data has been read, set the CBnSCE bit to "1" and dummy-read the CBnRX register.
  3. To start the reception, dummy reading is necessary.



**(a) How to use CBnSCE bit****(i) In single reception mode**

- <1> When the reception of the last data is completed with INTCBnR interrupt servicing, clear the CBnSCE bit to 0, and then read the CBnRX register.
- <2> When the reception is disabled after the reception of the last data has been completed, check that the CBnSTR.CBnTSF bit is 0, and then clear the CBnPWR and CBnRXE bits to 0. To continue reception, set the CBnSCE bit to 1 and start the next receive operation by performing a dummy read of the CBnRX register.

**(ii) In continuous reception mode**

- <1> Clear the CBnSCE bit to 0 during reception of the last data with INTCBnR interrupt servicing by the reception before the last reception, and then read the CBnRX register.
- <2> After receiving the INTCBnR signal of the last reception, read the last data from the CBnRX register.
- <3> When the reception is disabled after the reception of the last data has been completed, check that the CBnSTR.CBnTSF bit is 0, and then clear the CBnPWR and CBnRXE bits to 0. To continue reception, set the CBnSCE bit to 1 and start the next receive operation by performing a dummy read of the CBnRX register.

**Caution** In continuous reception mode, the serial clock is not stopped until the reception executed when the CBnSCE bit is cleared to 0 is completed after the reception is started by a dummy read.

**(2) CSIBn control register 1 (CBnCTL1)**

CBnCTL1 is an 8-bit register that controls the CSIBn serial transfer operation.

This register can be read or written in 8-bit or 1-bit units.

Reset sets this register to 00H.

**Caution** The CBnCTL1 register can be rewritten only when the CBnCTL0.CBnPWR bit = 0.

After reset 00H R/W Address: CB0CTL1 FFFFFFFD01H, CB1CTL1 FFFFFFFD11H,  
 CB2CTL1 FFFFFFFD21H, CB3CTL1 FFFFFFFD31H,  
 CB4CTL1 FFFFFFFD41H, CB5CTL1 FFFFFFFD51H

	7	6	5	4	3	2	1	0
CBnCTL1 (n = 0 to 5)	0	0	0	CBnCKP	CBnDAP	CBnCKS2	CBnCKS1	CBnCKS0

	CBnCKP	CBnDAP	Specification of data transmission/ reception timing in relation to SCKBn
Communication type 1	0	0	
Communication type 2	0	1	
Communication type 3	1	0	
Communication type 4	1	1	

CBnCKS2	CBnCKS1	CBnCKS0	Communication clock (f <sub>CLK</sub> ) <sup>Note</sup>	Mode
0	0	0	f <sub>XP</sub> /2	Master mode
0	0	1	f <sub>XP</sub> /4	Master mode
0	1	0	f <sub>XP</sub> /8	Master mode
0	1	1	f <sub>XP</sub> /16	Master mode
1	0	0	f <sub>XP</sub> /32	Master mode
1	0	1	f <sub>XP</sub> /64	Master mode
1	1	0	f <sub>BRGm</sub>	Master mode
1	1	1	External clock (SCKBn)	Slave mode

**Note** Set the communication clock (f<sub>CLK</sub>) to 8 MHz or lower.

- Remarks 1.** m = 1 (n = 0, 1)  
 m = 2 (n = 2, 3)  
 m = 3 (n = 4, 5)

For details of f<sub>BRGm</sub>, see **17.8 Baud Rate Generator**.

- 2.** f<sub>XP</sub>: Peripheral clock frequency (Prescaler 1 input clock frequency)  
 In clock mode 1, f<sub>XP</sub> = f<sub>XX</sub>  
 In clock mode 2, f<sub>XP</sub> = f<sub>XMPLL</sub>/2 (14.64 to 16 MHz)  
 In clock mode 3, f<sub>XP</sub> = f<sub>XMPLL</sub> (29.28 to 32 MHz)  
 In clock mode 4, f<sub>XP</sub> = f<sub>XMPLL</sub>/2 (20.88 to 24 MHz)

f<sub>XX</sub>: Main clock frequency

f<sub>XMPLL</sub>: PLL output clock frequency for peripheral clock

**(3) CSIBn control register 2 (CBnCTL2)**

CBnCTL2 is an 8-bit register that controls the number of CSIBn serial transfer bits.

This register can be read or written in 8-bit units.

Reset sets this register to 00H.

**Caution** The CBnCTL2 register can be rewritten only when the CBnCTL0.CBnPWR bit = 0 or when both the CBnTXE and CBnRXE bits = 0.

After reset: 00H    R/W    Address: CB0CTL2 FFFFFFFD02H, CB1CTL2 FFFFFFFD12H,  
 CB2CTL2 FFFFFFFD22H, CB3CTL2 FFFFFFFD32H,  
 CB4CTL2 FFFFFFFD42H, CB5CTL2 FFFFFFFD52H

	7	6	5	4	3	2	1	0
CBnCTL2 (n = 0 to 5)	0	0	0	0	CBnCL3	CBnCL2	CBnCL1	CBnCL0

CBnCL3	CBnCL2	CBnCL1	CBnCL0	Serial register bit length
0	0	0	0	8 bits
0	0	0	1	9 bits
0	0	1	0	10 bits
0	0	1	1	11 bits
0	1	0	0	12 bits
0	1	0	1	13 bits
0	1	1	0	14 bits
0	1	1	1	15 bits
1	×	×	×	16 bits

- Remarks**
1. If the number of transfer bits is other than 8 or 16, prepare and use data stuffed from the LSB of the CBnTX and CBnRX registers.
  2. ×: don't care

**(a) Transfer data length change function**

The CSIB<sub>n</sub> transfer data length can be set in 1-bit units between 8 and 16 bits using the CBnCTL2.CBnCL3 to CBnCTL2.CBnCL0 bits.

When the transfer bit length is set to a value other than 16 bits, set the data to the CBnTX or CBnRX register starting from the LSB, regardless of whether the transfer start bit is the MSB or LSB. Any data can be set for the higher bits that are not used, but the receive data becomes 0 following serial transfer.

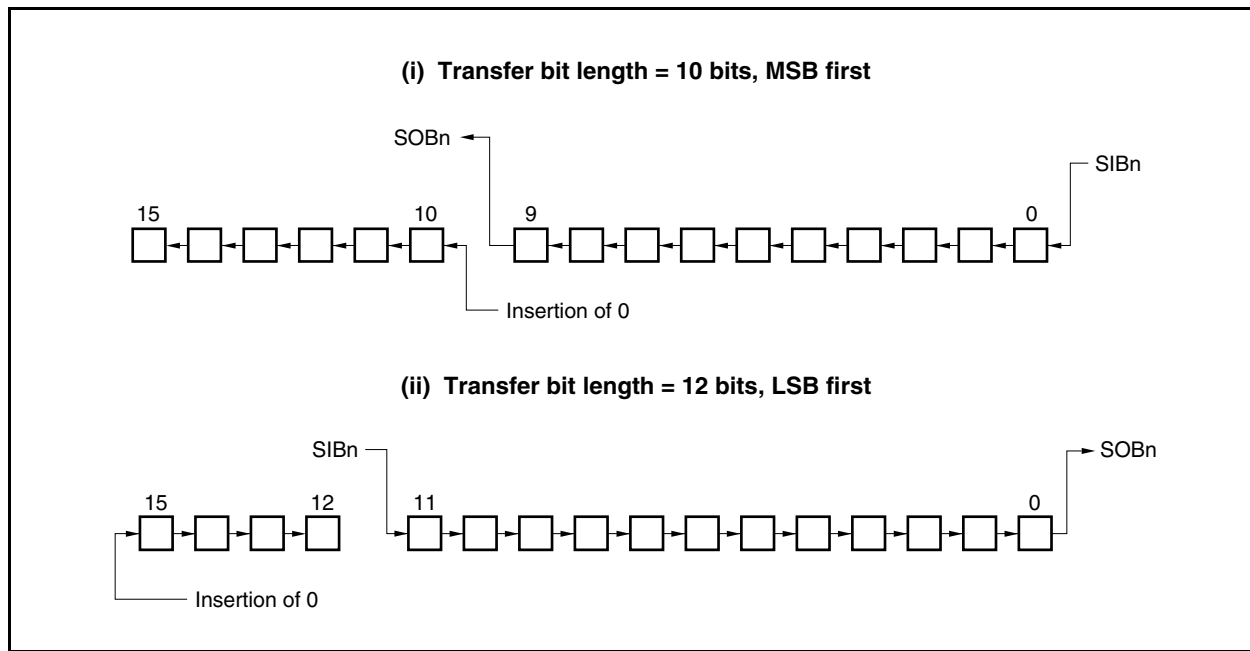

**(4) CSIBn status register (CBnSTR)**

CBnSTR is an 8-bit register that displays the CSIBn status.

This register can be read or written in 8-bit or 1-bit units, but the CBnTSF flag is read-only.

Reset sets this register to 00H.

In addition to reset input, the CBnSTR register can be initialized by clearing (0) the CBnCTL0.CBnPWR bit.

After reset: 00H    R/W    Address: CB0STR FFFF03H, CB1STR FFFF13H,  
 CB2STR FFFF23H, CB3STR FFFF33H,  
 CB4STR FFFF43H, CB5STR FFFF53H

	<7>	6	5	4	3	2	1	<0>
CBnSTR	CBnTSF	0	0	0	0	0	0	CBnOVE

(n = 0 to 5)

CBnTSF	Communication status flag
0	Communication stopped
1	Communicating
<ul style="list-style-type: none"> <li>• During transmission, this register is set when data is prepared in the CBnTX register, and during reception, it is set when a dummy read of the CBnRX register is performed.</li> <li>• When transfer ends, this flag is cleared to 0 at the last edge of the clock.</li> </ul>	

CBnOVE	Overrun error flag
0	No overrun
1	Overrun
<ul style="list-style-type: none"> <li>• An overrun error occurs when the next reception starts without reading the value of the CBnRX register by CPU, upon completion of the receive operation. The CBnOVE flag displays the overrun error occurrence status in this case.</li> <li>• The CBnOVE bit is valid also in the single transfer mode. Therefore, when only using transmission, note the following.                     <ul style="list-style-type: none"> <li>• Do not check the CBnOVE flag. (recommended)</li> <li>• Read this bit even if reading the reception data is not required.</li> </ul> </li> <li>• The CBnOVE flag is cleared by writing 0 to it. It cannot be set even by writing 1 to it.</li> </ul>	

**Caution** In single transfer mode, writing to the CBnTX register with the CBnTSF bit set to 1 is ignored. This has no influence on the operation during transfer.

For example, if the next data is written to the CBnTX register when DMA is started by generating the INTCBnR signal, the written data is not transferred because the CBnTSF bit is set to 1.

Use the continuous transfer mode, not the single transfer mode, for such applications.

## 17.5 Interrupt Request Signals

CSIBn can generate the following two types of interrupt request signals.

- Reception completion interrupt request signal (INTCBnR)
- Transmission enable interrupt request signal (INTCBnT)

Of these two interrupt request signals, the reception completion interrupt request signal has the higher priority by default, and the priority of the transmission enable interrupt request signal is lower.

**Table 17-4. Interrupts and Their Default Priority**

Interrupt	Priority
Reception complete	High
Transmission enable	Low

### (1) Reception completion interrupt request signal (INTCBnR)

When receive data is transferred to the CBnRX register while reception is enabled, the reception completion interrupt request signal is generated.

This interrupt request signal can also be generated if an overrun error occurs.

When the reception completion interrupt request signal is acknowledged and the data is read, read the CBnSTR register to check that the result of reception is not an error.

In the single transfer mode, the INTCBnR interrupt request signal is generated upon completion of transmission, even when only transmission is executed.

### (2) Transmission enable interrupt request signal (INTCBnT)

In the continuous transmission or continuous transmission/reception mode, transmit data is transferred from the CBnTX register and, as soon as writing to CBnTX has been enabled, the transmission enable interrupt request signal is generated.

In the single transmission and single transmission/reception modes, the INTCBnT interrupt is not generated.

## 17.6 Operation

### 17.6.1 Single transfer mode (master mode, transmission mode)

MSB first (CBnCTL0.CBnDIR bit = 0), communication type 1 (CBnCTL1.CBnCKP and CBnCTL1.CBnDAP bits = 00), communication clock ( $f_{\text{CCLK}} = f_{\text{XP}}/2$  (CBnCTL1.CBnCKS2 to CBnCTL1.CBnCKS0 bits = 000), transfer data length = 8 bits (CBnCTL2.CBnCL3 to CBnCTL2.CBnCL0 bits = 0000)

**Remark**  $f_{\text{XP}}$ : Peripheral clock frequency (Prescaler 1 input clock frequency)

In clock mode 1,  $f_{\text{XP}} = f_{\text{XX}}$

In clock mode 2,  $f_{\text{XP}} = f_{\text{XMPLL}}/2$  (14.64 to 16 MHz)

In clock mode 3,  $f_{\text{XP}} = f_{\text{XMPLL}}$  (29.28 to 32 MHz)

In clock mode 4,  $f_{\text{XP}} = f_{\text{XMPLL}}/2$  (20.88 to 24 MHz)

$f_{\text{XX}}$ : Main clock frequency

$f_{\text{XMPLL}}$ : PLL output clock frequency for peripheral clock

#### (1) Operation flow

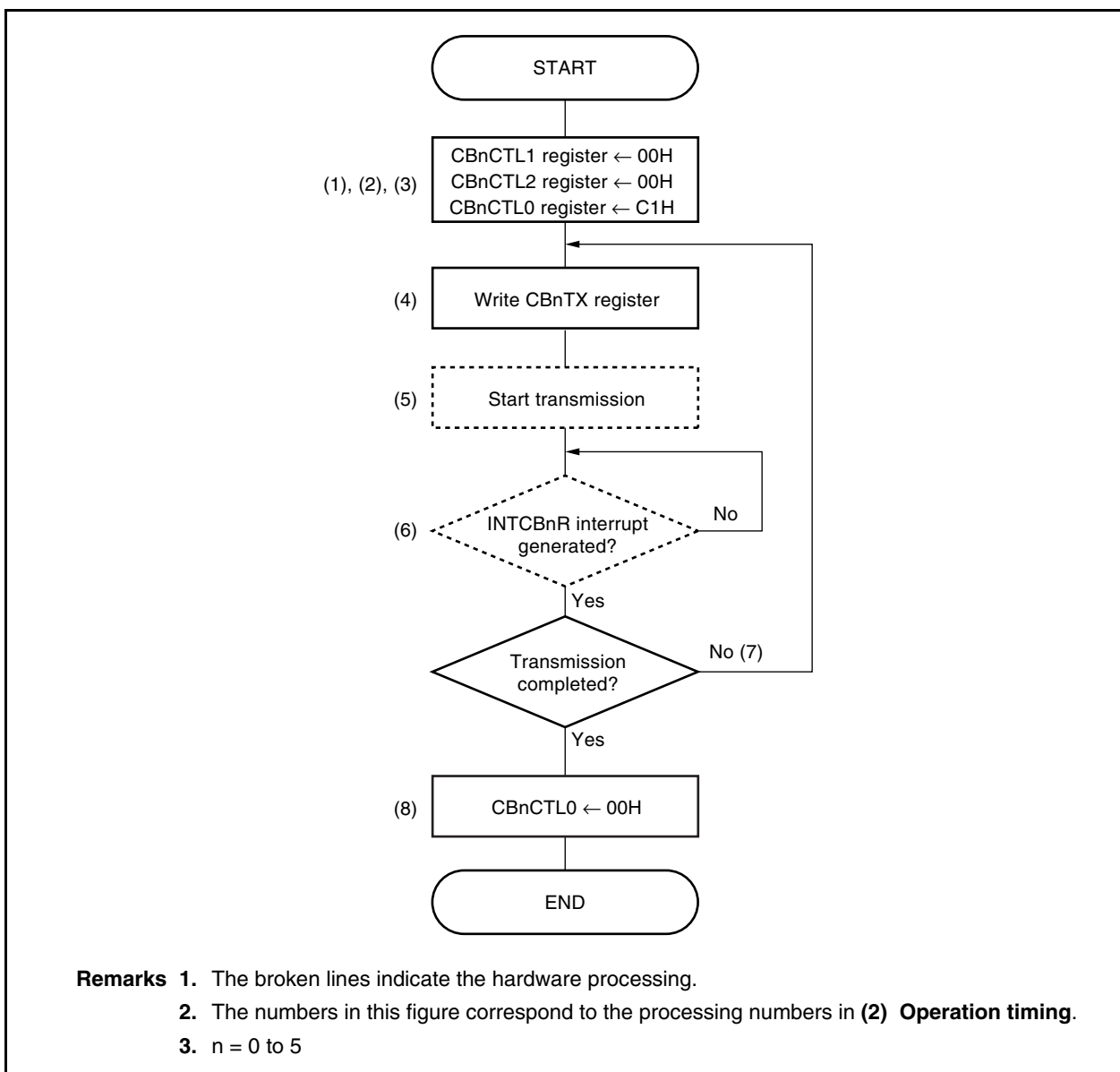

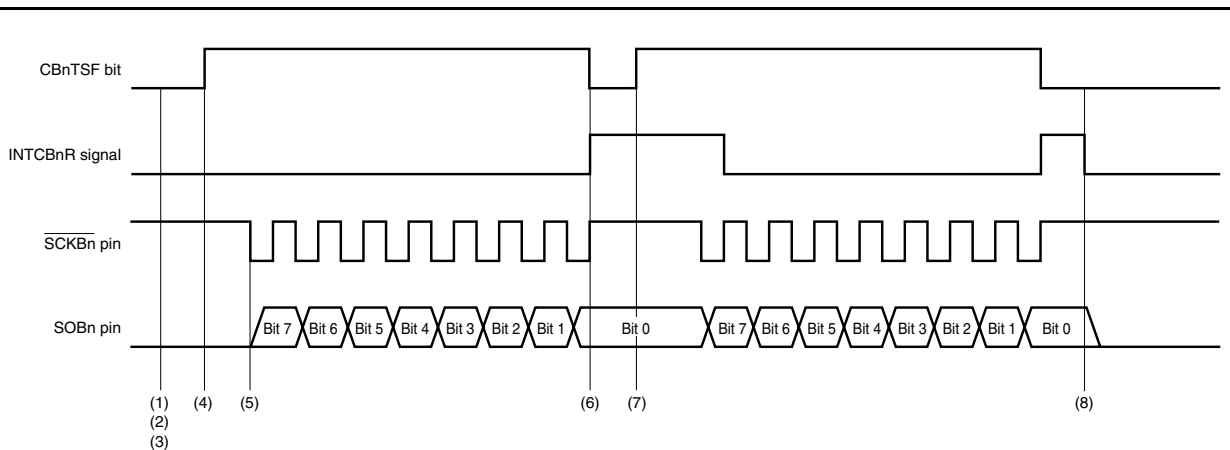
**(2) Operation timing**

- (1) Write 00H to the CBnCTL1 register, and select communication type 1, communication clock ( $f_{\text{CLK}}$ ) =  $f_{\text{XP}}/2$ , and master mode.
- (2) Write 00H to the CBnCTL2 register, and set the transfer data length to 8 bits.
- (3) Write C1H to the CBnCTL0 register, and select the transmission mode and MSB first at the same time as enabling the operation of the communication clock ( $f_{\text{CLK}}$ ).
- (4) The CBnSTR.CBnTSF bit is set to 1 by writing the transmit data to the CBnTX register, and transmission is started.
- (5) When transmission is started, output the serial clock to the  $\overline{\text{SCKBn}}$  pin, and output the transmit data from the SOBn pin in synchronization with the serial clock.
- (6) When transmission of the transfer data length set with the CBnCTL2 register is completed, stop the serial clock output and transmit data output, generate the reception completion interrupt request signal (INTCBnR) at the last edge of the serial clock, and clear the CBnTSF bit to 0.
- (7) To continue transmission, start the next transmission by writing the transmit data to the CBnTX register again after the INTCBnR signal is generated.
- (8) To end transmission, write the CBnCTL0.CBnPWR bit = 0 and the CBnCTL0.CBnTXE bit = 0.

**Remarks 1.**  $n = 0$  to 5

2.  $f_{\text{XP}}$ : Peripheral clock frequency (Prescaler 1 input clock frequency)

In clock mode 1,  $f_{\text{XP}} = f_{\text{XX}}$

In clock mode 2,  $f_{\text{XP}} = f_{\text{XMPLL}}/2$  (14.64 to 16 MHz)

In clock mode 3,  $f_{\text{XP}} = f_{\text{XMPLL}}$  (29.28 to 32 MHz)

In clock mode 4,  $f_{\text{XP}} = f_{\text{XMPLL}}/2$  (20.88 to 24 MHz)

$f_{\text{XX}}$ : Main clock frequency

$f_{\text{XMPLL}}$ : PLL output clock frequency for peripheral clock



**17.6.2 Single transfer mode (master mode, reception mode)**

MSB first (CBnCTL0.CBnDIR bit = 0), communication type 1 (CBnCTL1.CBnCKP and CBnCTL1.CBnDAP bits = 00), communication clock ( $f_{\text{CLK}}$ ) =  $f_{\text{XP}}/2$  (CBnCTL1.CBnCKS2 to CBnCTL1.CBnCKS0 bits = 000), transfer data length = 8 bits (CBnCTL2.CBnCL3 to CBnCTL2.CBnCL0 bits = 0000)

**Remark**  $f_{\text{XP}}$ : Peripheral clock frequency (Prescaler 1 input clock frequency)

In clock mode 1,  $f_{\text{XP}} = f_{\text{XX}}$

In clock mode 2,  $f_{\text{XP}} = f_{\text{XMPLL}}/2$  (14.64 to 16 MHz)

In clock mode 3,  $f_{\text{XP}} = f_{\text{XMPLL}}$  (29.28 to 32 MHz)

In clock mode 4,  $f_{\text{XP}} = f_{\text{XMPLL}}/2$  (20.88 to 24 MHz)

$f_{\text{XX}}$ : Main clock frequency

$f_{\text{XMPLL}}$ : PLL output clock frequency for peripheral clock

## (1) Operation flow

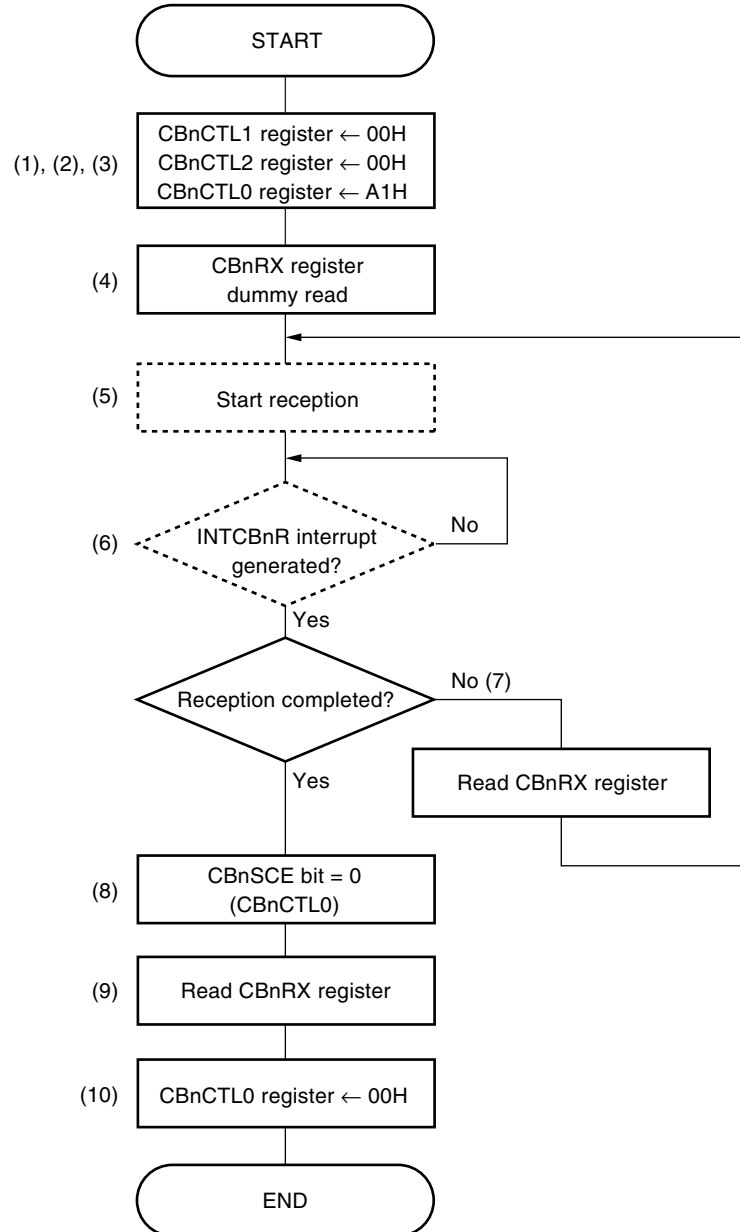

- Remarks**
1. The broken lines indicate the hardware processing.
  2. The numbers in this figure correspond to the processing numbers in (2) **Operation timing**.
  3.  $n = 0$  to 5

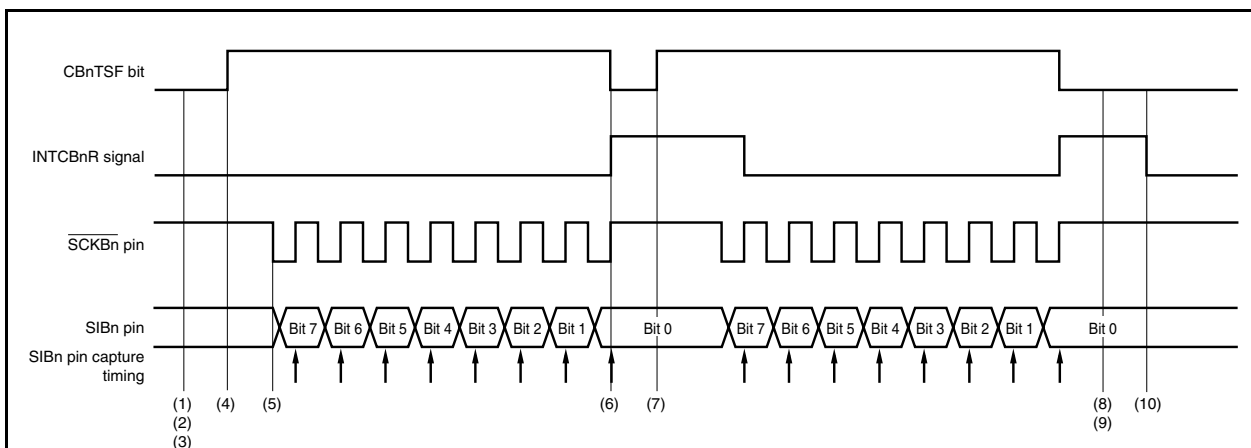
**(2) Operation timing**

- (1) Write 00H to the CBnCTL1 register, and select communication type 1, communication clock ( $f_{CCLK}$ ) =  $f_{XP}/2$ , and master mode.
- (2) Write 00H to the CBnCTL2 register, and set the transfer data length to 8 bits.
- (3) Write A1H to the CBnCTL0 register, and select the reception mode and MSB first at the same time as enabling the operation of the communication clock ( $f_{CCLK}$ ).
- (4) The CBnSTR.CBnTSP bit is set to 1 by performing a dummy read of the CBnRX register, and reception is started.
- (5) When reception is started, output the serial clock to the  $\overline{SCKBn}$  pin, and capture the receive data of the SIBn pin in synchronization with the serial clock.
- (6) When reception of the transfer data length set with the CBnCTL2 register is completed, stop the serial clock output and data capturing, generate the reception completion interrupt request signal (INTCBnR) at the last edge of the serial clock, and clear the CBnTSP bit to 0.
- (7) To continue reception, read the CBnRX register with the CBnCTL0.CBnSCE bit = 1 remained after the INTCBnR signal is generated.
- (8) To read the CBnRX register without starting the next reception, write the CBnSCE bit = 0.
- (9) Read the CBnRX register.
- (10) To end reception, write the CBnCTL0.CBnPWR bit = 0 and the CBnCTL0.CBnRXE bit = 0.

**Remarks 1.**  $n = 0$  to 5

2.  $f_{XP}$ : Peripheral clock frequency (Prescaler 1 input clock frequency)

In clock mode 1,  $f_{XP} = f_{XX}$

In clock mode 2,  $f_{XP} = f_{XMPLL}/2$  (14.64 to 16 MHz)

In clock mode 3,  $f_{XP} = f_{XMPLL}$  (29.28 to 32 MHz)

In clock mode 4,  $f_{XP} = f_{XMPLL}/2$  (20.88 to 24 MHz)

$f_{XX}$ : Main clock frequency

$f_{XMPLL}$ : PLL output clock frequency for peripheral clock

**17.6.3 Single transfer mode (master mode, transmission/reception mode)**

MSB first (CBnCTL0.CBnDIR bit = 0), communication type 1 (CBnCTL1.CBnCKP and CBnCTL1.CBnDAP bits = 00), communication clock ( $f_{\text{CLK}}$ ) =  $f_{\text{XP}}/2$  (CBnCTL1.CBnCKS2 to CBnCTL1.CBnCKS0 bits = 000), transfer data length = 8 bits (CBnCTL2.CBnCL3 to CBnCTL2.CBnCL0 bits = 0000)

**Remark**  $f_{\text{XP}}$ : Peripheral clock frequency (Prescaler 1 input clock frequency)

In clock mode 1,  $f_{\text{XP}} = f_{\text{XX}}$

In clock mode 2,  $f_{\text{XP}} = f_{\text{XMPLL}}/2$  (14.64 to 16 MHz)

In clock mode 3,  $f_{\text{XP}} = f_{\text{XMPLL}}$  (29.28 to 32 MHz)

In clock mode 4,  $f_{\text{XP}} = f_{\text{XMPLL}}/2$  (20.88 to 24 MHz)

$f_{\text{XX}}$ : Main clock frequency

$f_{\text{XMPLL}}$ : PLL output clock frequency for peripheral clock

## (1) Operation flow

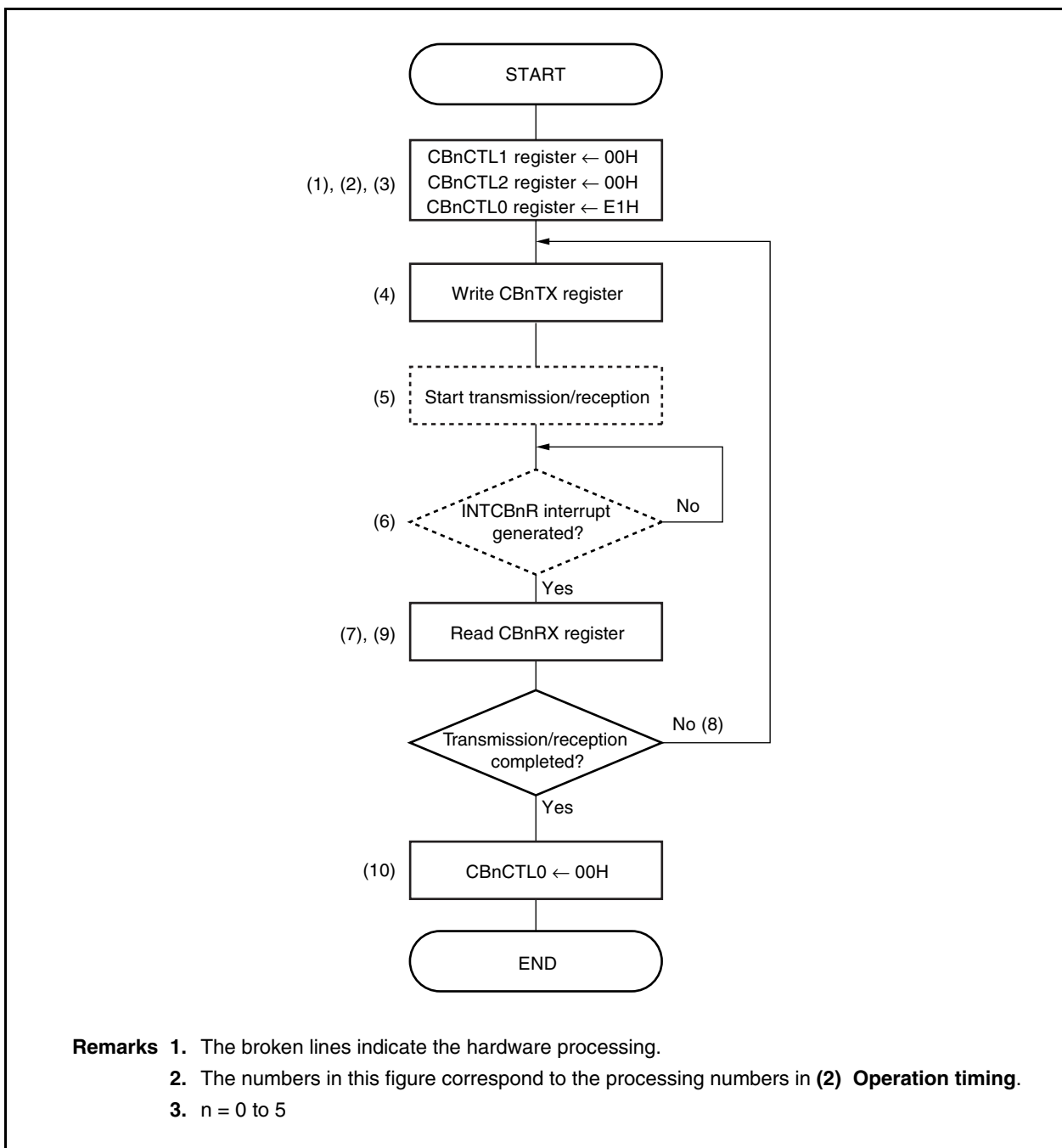

## (2) Operation timing

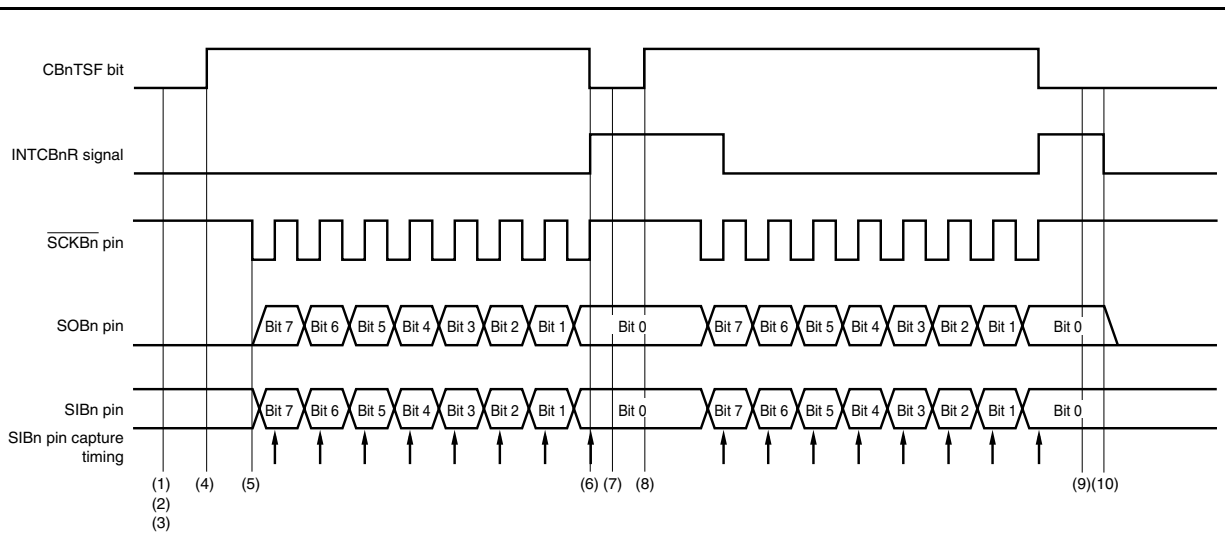

- (1) Write 00H to the CBnCTL1 register, and select communication type 1, communication clock ( $f_{\text{CLK}}$ ) =  $f_{\text{XP}}/2$ , and master mode.
- (2) Write 00H to the CBnCTL2 register, and set the transfer data length to 8 bits.
- (3) Write E1H to the CBnCTL0 register, and select the transmission/reception mode and MSB first at the same time as enabling the operation of the communication clock ( $f_{\text{CLK}}$ ).
- (4) The CBnSTR.CBnTSF bit is set to 1 by writing the transmit data to the CBnTX register, and transmission/reception is started.
- (5) When transmission/reception is started, output the serial clock to the  $\overline{\text{SCKBn}}$  pin, output the transmit data to the SOBn pin in synchronization with the serial clock, and capture the receive data of the SIBn pin.
- (6) When transmission/reception of the transfer data length set with the CBnCTL2 register is completed, stop the serial clock output, transmit data output, and data capturing, generate the reception completion interrupt request signal (INTCBnR) at the last edge of the serial clock, and clear the CBnTSF bit to 0.
- (7) Read the CBnRX register.
- (8) To continue transmission/reception, write the transmit data to the CBnTX register again.
- (9) Read the CBnRX register.
- (10) To end transmission/reception, write the CBnCTL0.CBnPWR bit = 0, the CBnCTL0.CBnTXE bit = 0, and the CBnCTL0.CBnRXE bit = 0.

**Remarks 1.**  $n = 0$  to 5

2.  $f_{\text{XP}}$ : Peripheral clock frequency (Prescaler 1 input clock frequency)

In clock mode 1,  $f_{\text{XP}} = f_{\text{XX}}$

In clock mode 2,  $f_{\text{XP}} = f_{\text{XMPLL}}/2$  (14.64 to 16 MHz)

In clock mode 3,  $f_{\text{XP}} = f_{\text{XMPLL}}$  (29.28 to 32 MHz)

In clock mode 4,  $f_{\text{XP}} = f_{\text{XMPLL}}/2$  (20.88 to 24 MHz)

$f_{\text{XX}}$ : Main clock frequency

$f_{\text{XMPLL}}$ : PLL output clock frequency for peripheral clock

**17.6.4 Single transfer mode (slave mode, transmission mode)**

MSB first (CBnCTL0.CBnDIR bit = 0), communication type 1 (CBnCTL1.CBnCKP and CBnCTL1.CBnDAP bits = 00), communication clock ( $f_{\text{CLK}}$ ) = external clock ( $\overline{\text{SCKBn}}$ ) (CBnCTL1.CBnCKS2 to CBnCTL1.CBnCKS0 bits = 111), transfer data length = 8 bits (CBnCTL2.CBnCL3 to CBnCTL2.CBnCL0 bits = 0000)

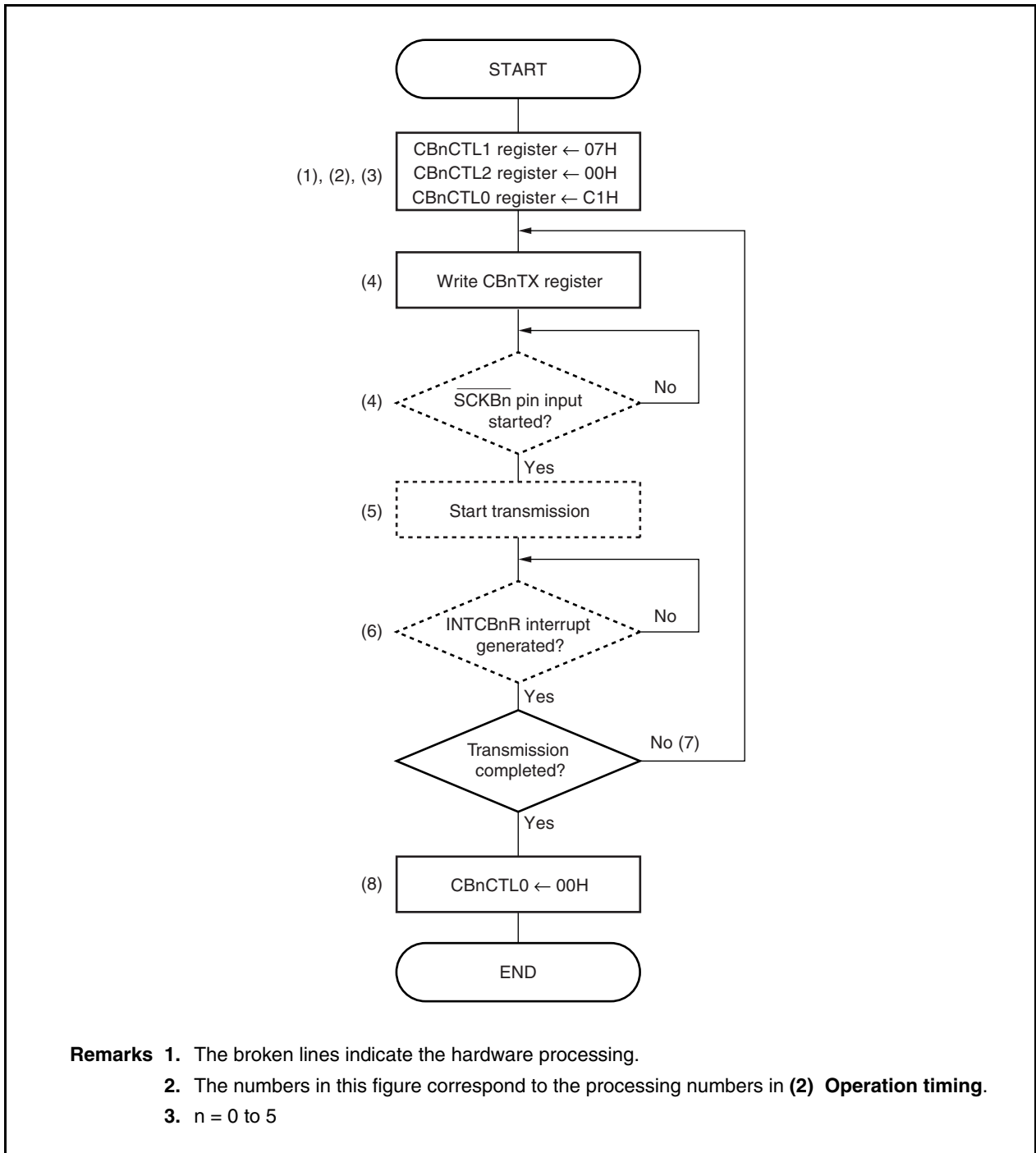
**(1) Operation flow**

- Remarks**
1. The broken lines indicate the hardware processing.
  2. The numbers in this figure correspond to the processing numbers in **(2) Operation timing**.
  3.  $n = 0$  to 5

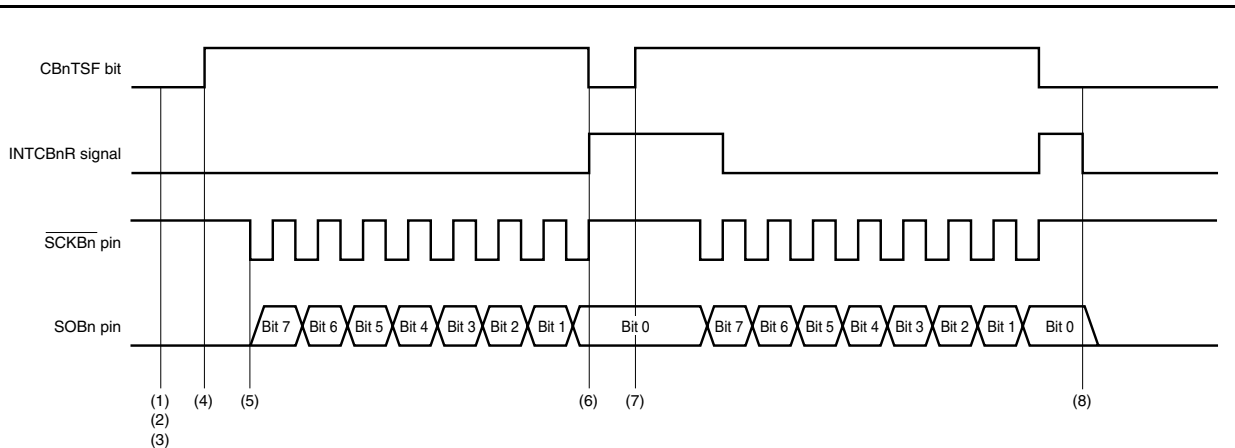
**(2) Operation timing**

- (1) Write 07H to the CBnCTL1 register, and select communication type 1, communication clock ( $f_{\text{CLK}}$ ) = external clock (SCKBn), and slave mode.
- (2) Write 00H to the CBnCTL2 register, and set the transfer data length to 8 bits.
- (3) Write C1H to the CBnCTL0 register, and select the transmission mode and MSB first at the same time as enabling the operation of the communication clock ( $f_{\text{CLK}}$ ).
- (4) The CBnSTR.CBnTSF bit is set to 1 by writing the transmit data to the CBnTX register, and the device waits for a serial clock input.
- (5) When a serial clock is input, output the transmit data from the SOBn pin in synchronization with the serial clock.
- (6) When transmission of the transfer data length set with the CBnCTL2 register is completed, stop the serial clock input and transmit data output, generate the reception completion interrupt request signal (INTCBnR) at the last edge of the serial clock, and clear the CBnTSF bit to 0.
- (7) To continue transmission, write the transmit data to the CBnTX register again after the INTCBnR signal is generated, and wait for a serial clock input.
- (8) To end transmission, write the CBnCTL0.CBnPWR bit = 0 and the CBnCTL0.CBnTXE bit = 0.

**Remark** n = 0 to 5



### 17.6.5 Single transfer mode (slave mode, reception mode)

MSB first (CBnCTL0.CBnDIR bit = 0), communication type 1 (CBnCTL1.CBnCKP and CBnCTL1.CBnDAP bits = 00), communication clock (f<sub>CLK</sub>) = external clock (SCKBn) (CBnCTL1.CBnCKS2 to CBnCTL1.CBnCKS0 bits = 111), transfer data length = 8 bits (CBnCTL2.CBnCL3 to CBnCTL2.CBnCL0 bits = 0000)

#### (1) Operation flow

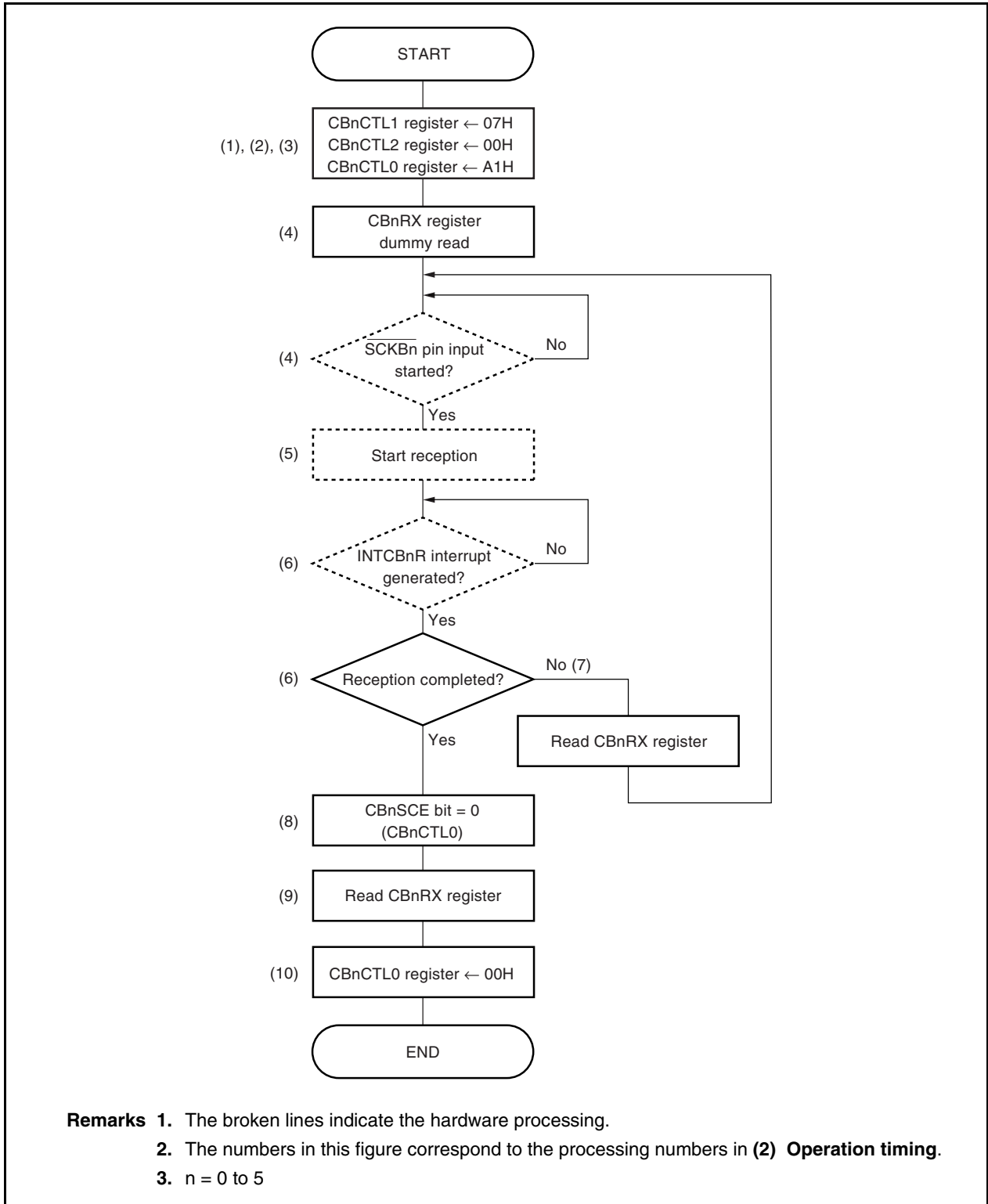

**Remarks 1.** The broken lines indicate the hardware processing.

**2.** The numbers in this figure correspond to the processing numbers in (2) **Operation timing**.

**3.** n = 0 to 5

## (2) Operation timing

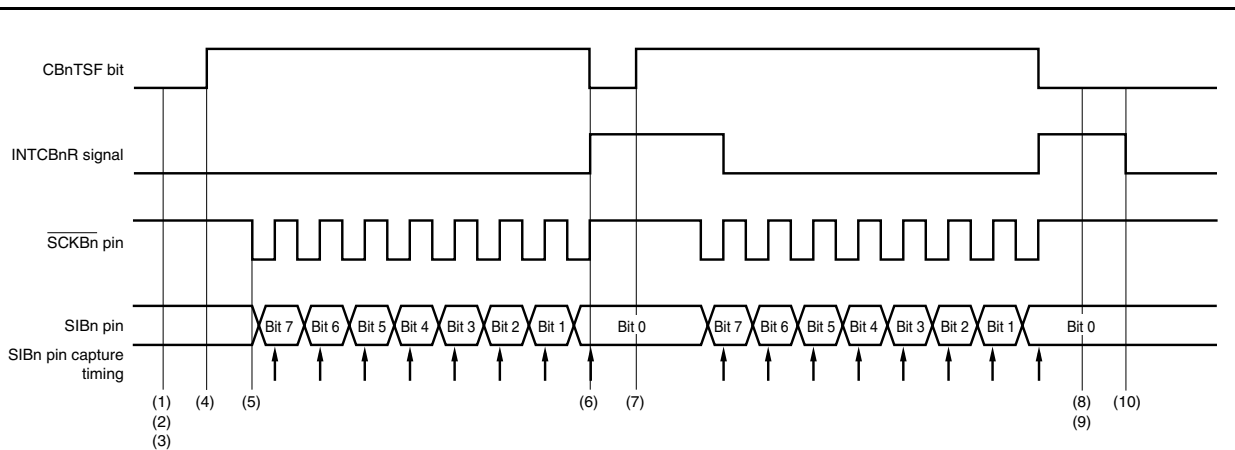

- (1) Write 07H to the `CBnCTL1` register, and select communication type 1, communication clock ( $f_{\text{CLK}}$ ) = external clock (`SCKBn`), and slave mode.
- (2) Write 00H to the `CBnCTL2` register, and set the transfer data length to 8 bits.
- (3) Write A1H to the `CBnCTL0` register, and select the reception mode and MSB first at the same time as enabling the operation of the communication clock ( $f_{\text{CLK}}$ ).
- (4) The `CBnSTR.CBnTSF` bit is set to 1 by performing a dummy read of the `CBnRX` register, and the device waits for a serial clock input.
- (5) When a serial clock is input, capture the receive data of the `SIBn` pin in synchronization with the serial clock.
- (6) When reception of the transfer data length set with the `CBnCTL2` register is completed, stop the serial clock input and data capturing, generate the reception completion interrupt request signal (`INTCBnR`) at the last edge of the serial clock, and clear the `CBnTSF` bit to 0.
- (7) To continue reception, read the `CBnRX` register with the `CBnCTL0.CBnSCE` bit = 1 remained after the `INTCBnR` signal is generated, and wait for a serial clock input.
- (8) To end reception, write the `CBnSCE` bit = 0.
- (9) Read the `CBnRX` register.
- (10) To end reception, write the `CBnCTL0.CBnPWR` bit = 0 and the `CBnCTL0.CBnRXE` bit = 0.

**Remark**  $n = 0$  to 5

**17.6.6 Single transfer mode (slave mode, transmission/reception mode)**

MSB first (CBnCTL0.CBnDIR bit = 0), communication type 1 (CBnCTL1.CBnCKP and CBnCTL1.CBnDAP bits = 00), communication clock ( $f_{CLK}$ ) = external clock ( $\overline{SCKBn}$ ) (CBnCTL1.CBnCKS2 to CBnCTL1.CBnCKS0 bits = 111), transfer data length = 8 bits (CBnCTL2.CBnCL3 to CBnCTL2.CBnCL0 bits = 0000)

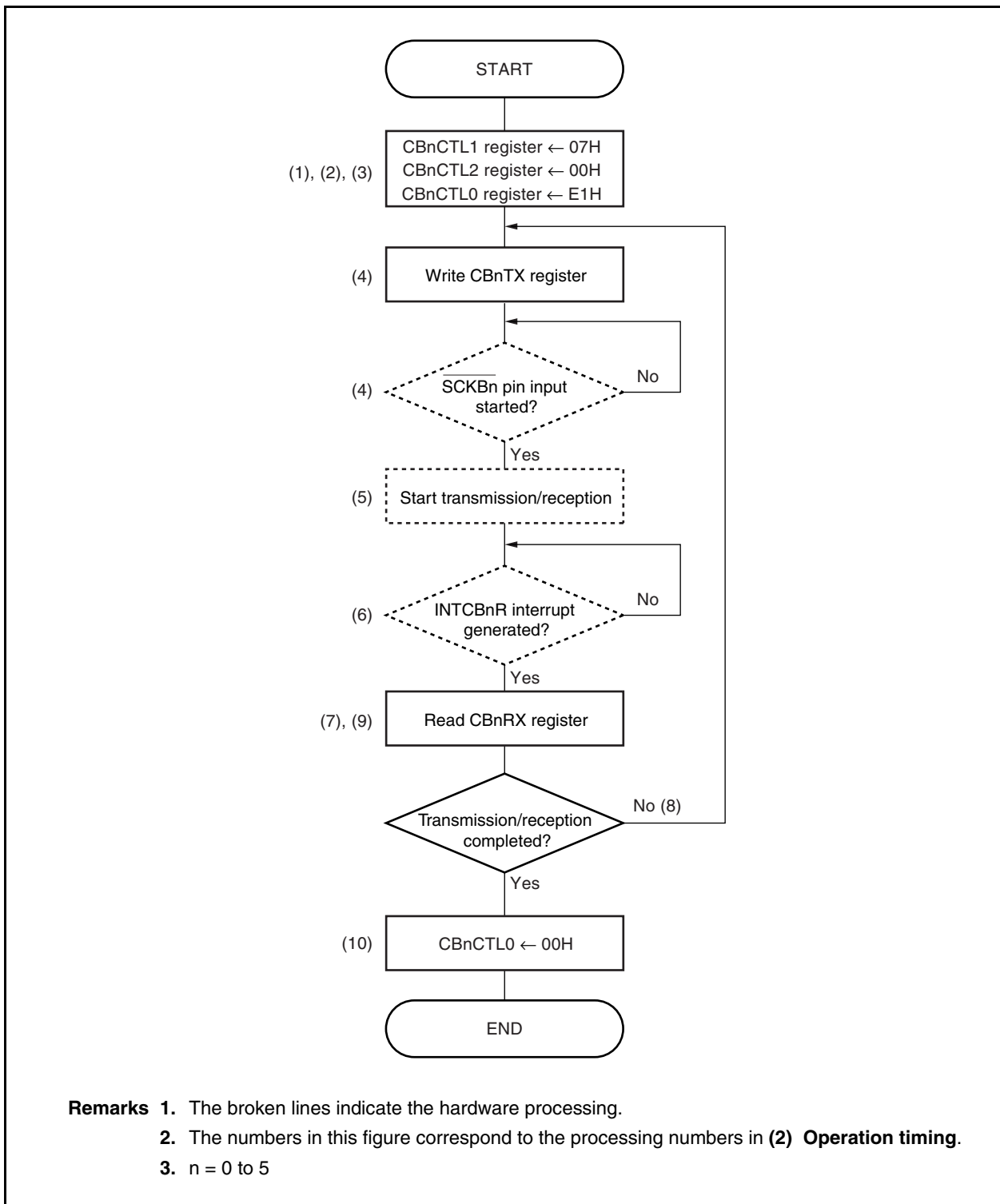
**(1) Operation flow**

- Remarks**
1. The broken lines indicate the hardware processing.
  2. The numbers in this figure correspond to the processing numbers in **(2) Operation timing**.
  3.  $n = 0$  to 5

## (2) Operation timing

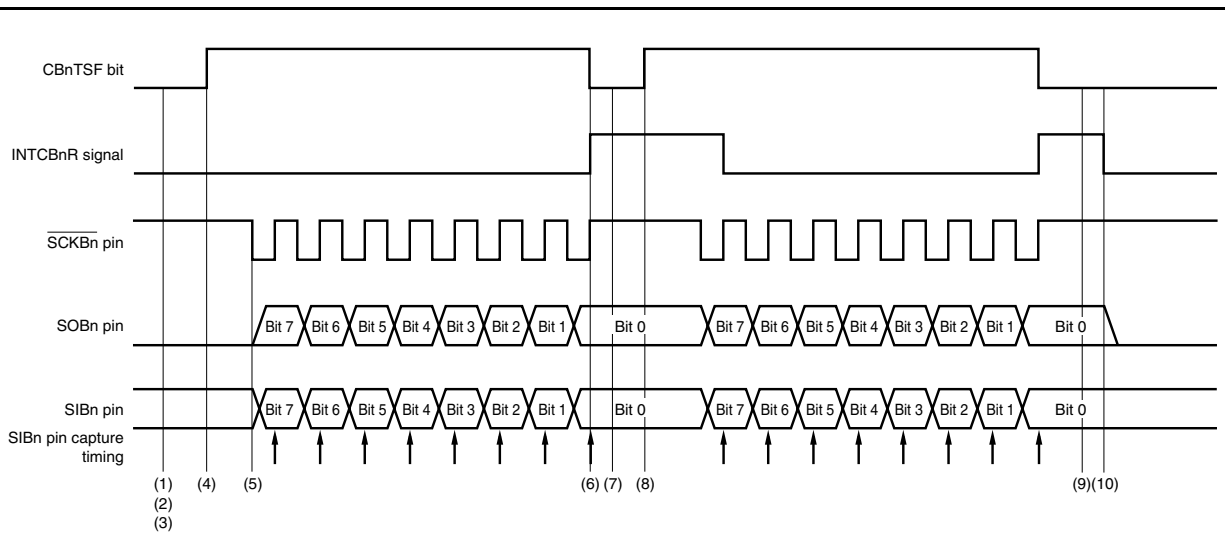

- (1) Write 07H to the CBNCTL1 register, and select communication type 1, communication clock ( $f_{\text{CCLK}}$ ) = external clock ( $\text{SCK}_{\text{Bn}}$ ), and slave mode.
- (2) Write 00H to the CBNCTL2 register, and set the transfer data length to 8 bits.
- (3) Write E1H to the CBNCTL0 register, and select the transmission/reception mode and MSB first at the same time as enabling the operation of the communication clock ( $f_{\text{CCLK}}$ ).
- (4) The CBNSTR.CBN\_TSF bit is set to 1 by writing the transmit data to the CBN\_TX register, and the device waits for a serial clock input.
- (5) When a serial clock is input, output the transmit data to the SOBn pin in synchronization with the serial clock, and capture the receive data of the SIBn pin.
- (6) When transmission/reception of the transfer data length set with the CBNCTL2 register is completed, stop the serial clock input, transmit data output, and data capturing, generate the reception completion interrupt request signal (INT\_CBN\_R) at the last edge of the serial clock, and clear the CBN\_TSF bit to 0.
- (7) Read the CBN\_RX register.
- (8) To continue transmission/reception, write the transmit data to the CBN\_TX register again, and wait for a serial clock input.
- (9) Read the CBN\_RX register.
- (10) To end transmission/reception, write the CBNCTL0.CBN\_PWR bit = 0, the CBNCTL0.CBN\_TXE bit = 0, and the CBNCTL0.CBN\_RXE bit = 0.

**Remark** n = 0 to 5

**17.6.7 Continuous transfer mode (master mode, transmission mode)**

MSB first (CBnCTL0.CBnDIR bit = 0), communication type 1 (CBnCTL1.CBnCKP and CBnCTL1.CBnDAP bits = 00), communication clock ( $f_{\text{CLK}}$ ) =  $f_{\text{XP}}/2$  (CBnCTL1.CBnCKS2 to CBnCTL1.CBnCKS0 bits = 000), transfer data length = 8 bits (CBnCTL2.CBnCL3 to CBnCTL2.CBnCL0 bits = 0000)

**Remark**  $f_{\text{XP}}$ : Peripheral clock frequency (Prescaler 1 input clock frequency)

In clock mode 1,  $f_{\text{XP}} = f_{\text{XX}}$

In clock mode 2,  $f_{\text{XP}} = f_{\text{XMPLL}}/2$  (14.64 to 16 MHz)

In clock mode 3,  $f_{\text{XP}} = f_{\text{XMPLL}}$  (29.28 to 32 MHz)

In clock mode 4,  $f_{\text{XP}} = f_{\text{XMPLL}}/2$  (20.88 to 24 MHz)

$f_{\text{XX}}$ : Main clock frequency

$f_{\text{XMPLL}}$ : PLL output clock frequency for peripheral clock

## (1) Operation flow

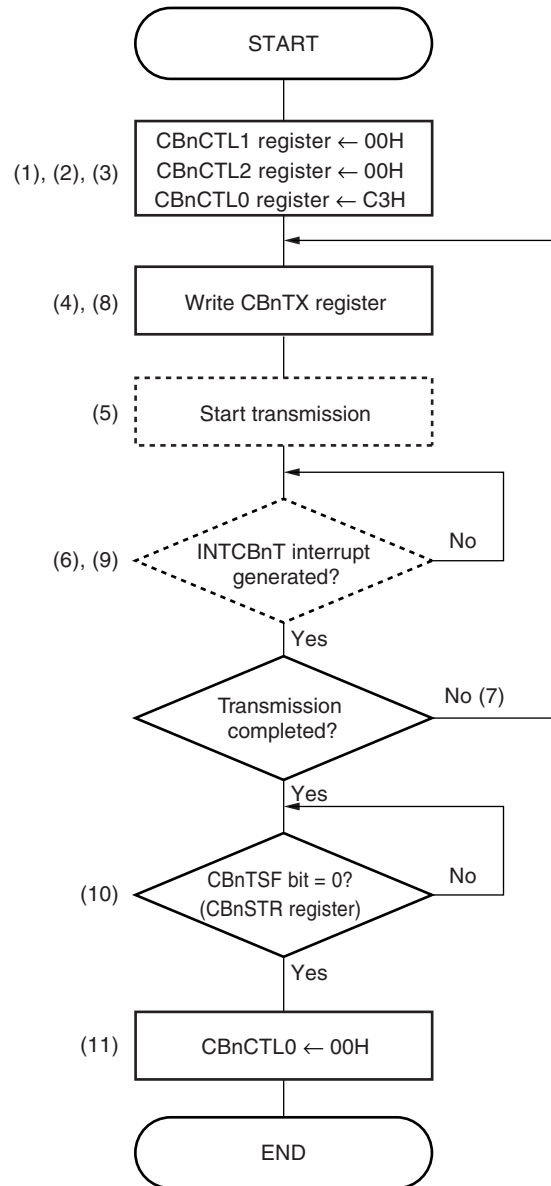

- Remarks**
1. The broken lines indicate the hardware processing.
  2. The numbers in this figure correspond to the processing numbers in (2) Operation timing.
  3.  $n = 0$  to 5

## (2) Operation timing

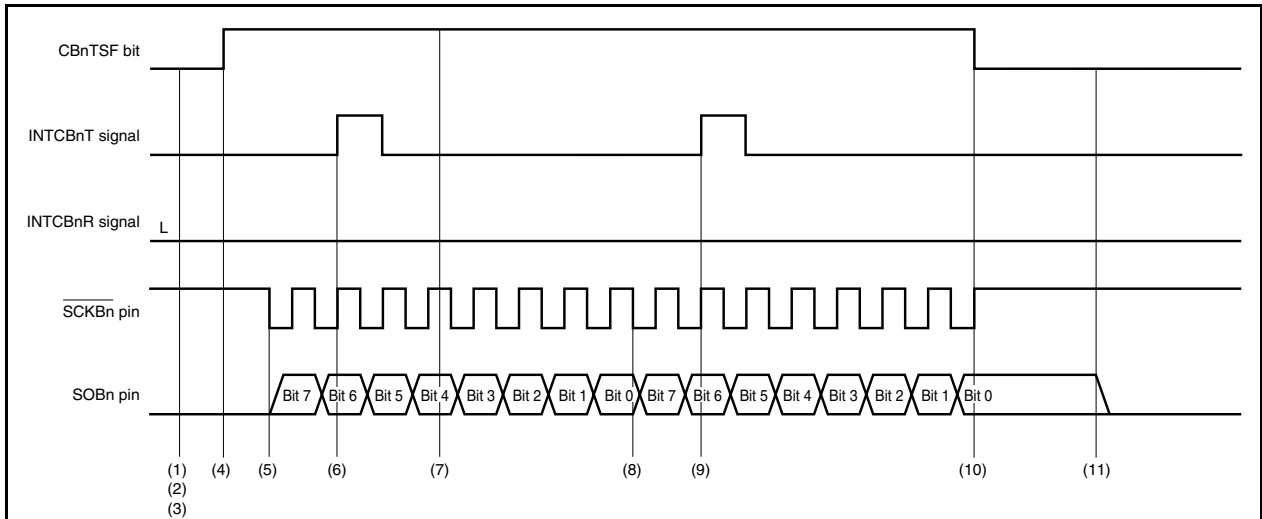

- (1) Write 00H to the CBnCTL1 register, and select communication type 1, communication clock ( $f_{CCLK} = f_{XP}/2$ , and master mode.
- (2) Write 00H to the CBnCTL2 register, and set the transfer data length to 8 bits.
- (3) Write C3H to the CBnCTL0 register, and select the transmission mode, MSB first, and continuous transfer mode at the same time as enabling the operation of the communication clock ( $f_{CCLK}$ ).
- (4) The CBnSTR.CBnTSF bit is set to 1 by writing the transmit data to the CBnTX register, and transmission is started.
- (5) When transmission is started, output the serial clock to the  $\overline{SCKBn}$  pin, and output the transmit data from the SOBn pin in synchronization with the serial clock.
- (6) When transfer of the transmit data from the CBnTX register to the shift register is completed and writing to the CBnTX register is enabled, the transmission enable interrupt request signal (INTCBnT) is generated.
- (7) To continue transmission, write the transmit data to the CBnTX register again after the INTCBnT signal is generated.
- (8) When a new transmit data is written to the CBnTX register before communication completion, the next communication is started following communication completion.
- (9) The transfer of the transmit data from the CBnTX register to the shift register is completed and the INTCBnT signal is generated. To end continuous transmission with the current transmission, do not write to the CBnTX register.
- (10) When the next transmit data is not written to the CBnTX register before transfer completion, stop the serial clock output to the  $\overline{SCKBn}$  pin after transfer completion, and clear the CBnTSF bit to 0.
- (11) To release the transmission enable status, write the CBnCTL0.CBnPWR bit = 0 and the CBnCTL0.CBnTXE bit = 0 after checking that the CBnTSF bit = 0.

**Caution** In continuous transmission mode, the reception completion interrupt request signal (INTCBnR) is not generated.

**Remarks 1.**  $n = 0$  to 5

**2.**  $f_{XP}$ : Peripheral clock frequency (Prescaler 1 input clock frequency)

In clock mode 1,  $f_{XP} = f_{XX}$

In clock mode 2,  $f_{XP} = f_{XMPLL}/2$  (14.64 to 16 MHz)

In clock mode 3,  $f_{XP} = f_{XMPLL}$  (29.28 to 32 MHz)

In clock mode 4,  $f_{XP} = f_{XMPLL}/2$  (20.88 to 24 MHz)

$f_{XX}$ : Main clock frequency

$f_{XMPLL}$ : PLL output clock frequency for peripheral clock

**17.6.8 Continuous transfer mode (master mode, reception mode)**

MSB first (CBnCTL0.CBnDIR bit = 0), communication type 1 (CBnCTL1.CBnCKP and CBnCTL1.CBnDAP bits = 00), communication clock ( $f_{\text{CLK}}$ ) =  $f_{\text{XP}}/2$  (CBnCTL1.CBnCKS2 to CBnCTL1.CBnCKS0 bits = 000), transfer data length = 8 bits (CBnCTL2.CBnCL3 to CBnCTL2.CBnCL0 bits = 0000)

**Remark**  $f_{\text{XP}}$ : Peripheral clock frequency (Prescaler 1 input clock frequency)

In clock mode 1,  $f_{\text{XP}} = f_{\text{XX}}$

In clock mode 2,  $f_{\text{XP}} = f_{\text{XMPLL}}/2$  (14.64 to 16 MHz)

In clock mode 3,  $f_{\text{XP}} = f_{\text{XMPLL}}$  (29.28 to 32 MHz)

In clock mode 4,  $f_{\text{XP}} = f_{\text{XMPLL}}/2$  (20.88 to 24 MHz)

$f_{\text{XX}}$ : Main clock frequency

$f_{\text{XMPLL}}$ : PLL output clock frequency for peripheral clock



(1) Operation flow

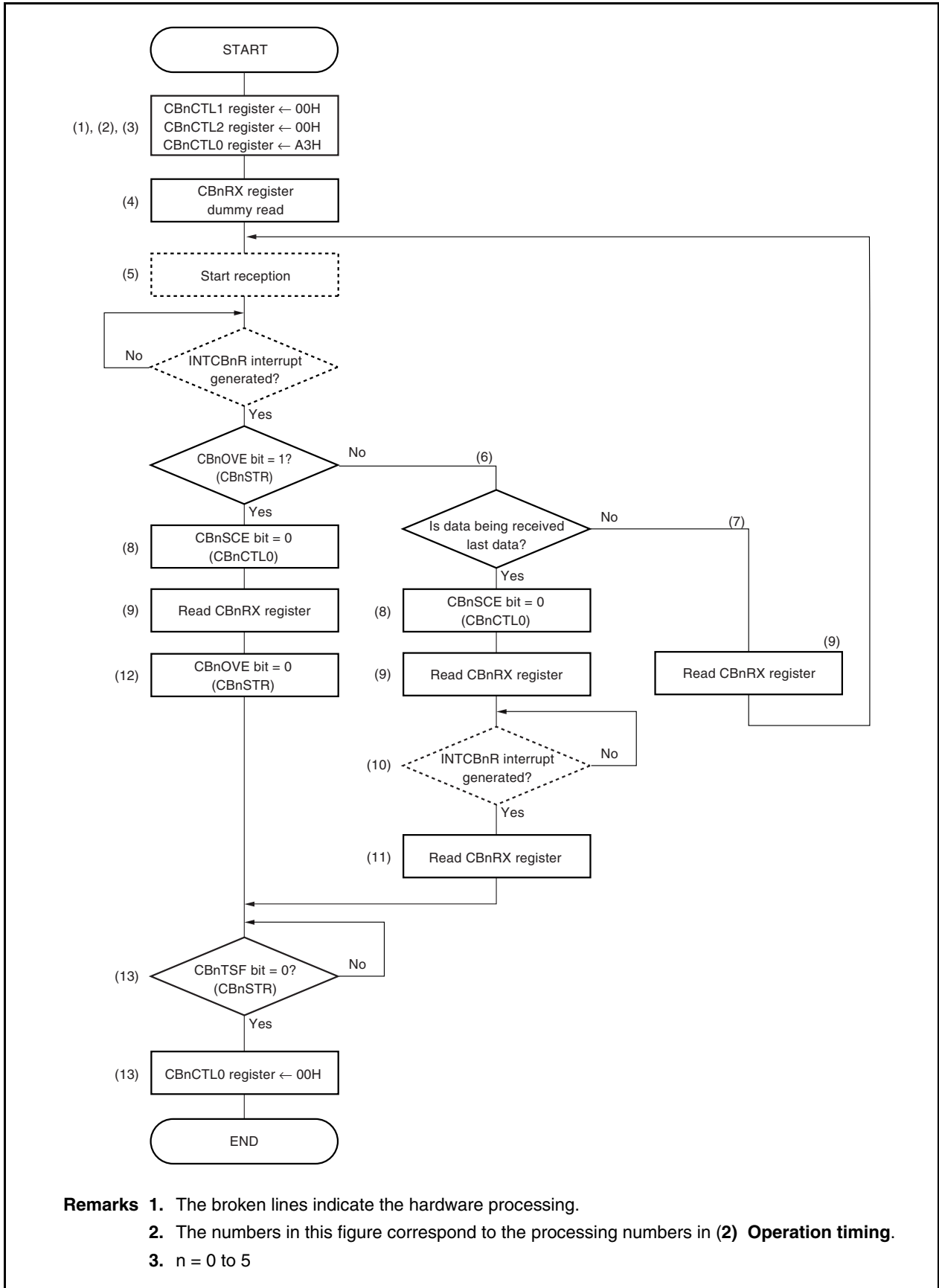

- Remarks**
1. The broken lines indicate the hardware processing.
  2. The numbers in this figure correspond to the processing numbers in (2) Operation timing.
  3. n = 0 to 5

## (2) Operation timing

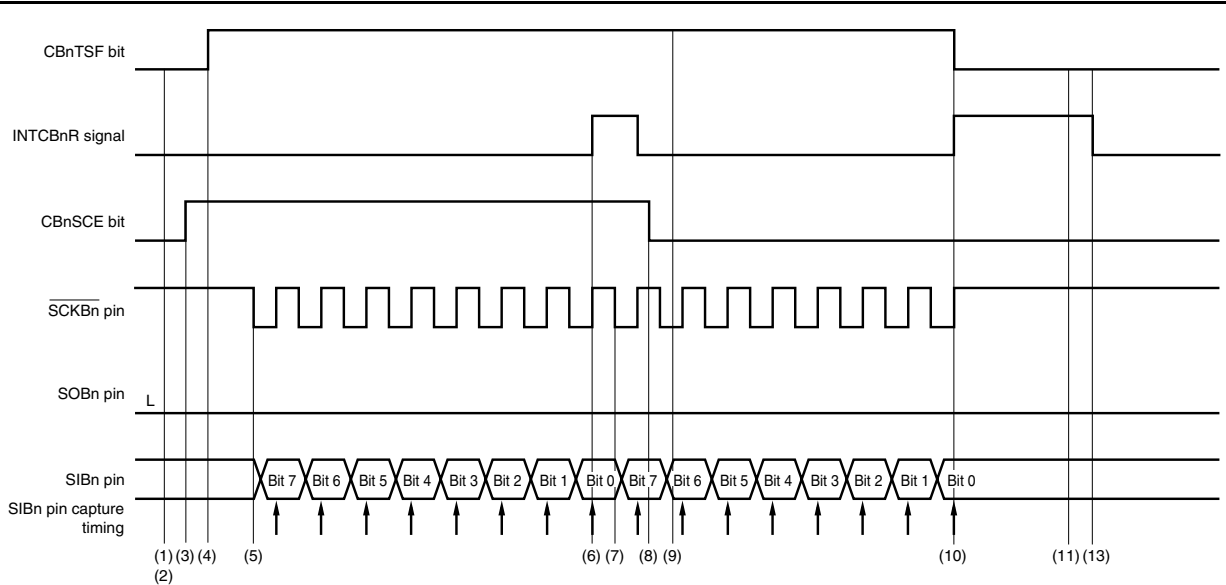

- (1) Write 00H to the CBnCTL1 register, and select communication type 1, communication clock ( $f_{\text{CCLK}} = f_{\text{XP}}/2$ , and master mode.
- (2) Write 00H to the CBnCTL2 register, and set the transfer data length to 8 bits.
- (3) Write A3H to the CBnCTL0 register, and select the reception mode, MSB first, and continuous transfer mode at the same time as enabling the operation of the communication clock ( $f_{\text{CCLK}}$ ).
- (4) The CBnSTR.CBnTSF bit is set to 1 by performing a dummy read of the CBnRX register, and reception is started.
- (5) When reception is started, output the serial clock to the SCKBn pin, and capture the receive data of the SIBn pin in synchronization with the serial clock.
- (6) When reception is completed, the reception completion interrupt request signal (INTCBnR) is generated, and reading of the CBnRX register is enabled.
- (7) When the CBnCTL0.CBnSCE bit = 1 upon communication completion, the next communication is started following communication completion.
- (8) To end continuous reception with the current reception, write the CBnSCE bit = 0.
- (9) Read the CBnRX register.
- (10) When reception is completed, the INTCBnR signal is generated, and reading of the CBnRX register is enabled. When the CBnSCE bit = 0 is set before communication completion, stop the serial clock output to the SCKBn pin, and clear the CBnTSF bit to 0, to end the receive operation.
- (11) Read the CBnRX register.
- (12) If an overrun error occurs, write the CBnSTR.CBnOVE bit = 0, and clear the error flag.
- (13) To release the reception enable status, write the CBnCTL0.CBnPWR bit = 0 and the CBnCTL0.CBnRXE bit = 0 after checking that the CBnTSF bit = 0.

**Remarks 1.**  $n = 0$  to 5

2.  $f_{\text{XP}}$ : Peripheral clock frequency (Prescaler 1 input clock frequency)

In clock mode 1,  $f_{\text{XP}} = f_{\text{XX}}$

In clock mode 2,  $f_{\text{XP}} = f_{\text{XMPLL}}/2$  (14.64 to 16 MHz)

In clock mode 3,  $f_{\text{XP}} = f_{\text{XMPLL}}$  (29.28 to 32 MHz)

In clock mode 4,  $f_{\text{XP}} = f_{\text{XMPLL}}/2$  (20.88 to 24 MHz)

$f_{\text{XX}}$ : Main clock frequency

$f_{\text{XMPLL}}$ : PLL output clock frequency for peripheral clock

**17.6.9 Continuous transfer mode (master mode, transmission/reception mode)**

MSB first (CBnCTL0.CBnDIR bit = 0), communication type 1 (CBnCTL1.CBnCKP and CBnCTL1.CBnDAP bits = 00), communication clock ( $f_{\text{CLK}}$ ) =  $f_{\text{XP}}/2$  (CBnCTL1.CBnCKS2 to CBnCTL1.CBnCKS0 bits = 000), transfer data length = 8 bits (CBnCTL2.CBnCL3 to CBnCTL2.CBnCL0 bits = 0000)

**Remark**  $f_{\text{XP}}$ : Peripheral clock frequency (Prescaler 1 input clock frequency)

In clock mode 1,  $f_{\text{XP}} = f_{\text{XX}}$

In clock mode 2,  $f_{\text{XP}} = f_{\text{XMPLL}}/2$  (14.64 to 16 MHz)

In clock mode 3,  $f_{\text{XP}} = f_{\text{XMPLL}}$  (29.28 to 32 MHz)

In clock mode 4,  $f_{\text{XP}} = f_{\text{XMPLL}}/2$  (20.88 to 24 MHz)

$f_{\text{XX}}$ : Main clock frequency

$f_{\text{XMPLL}}$ : PLL output clock frequency for peripheral clock

(1) Operation flow

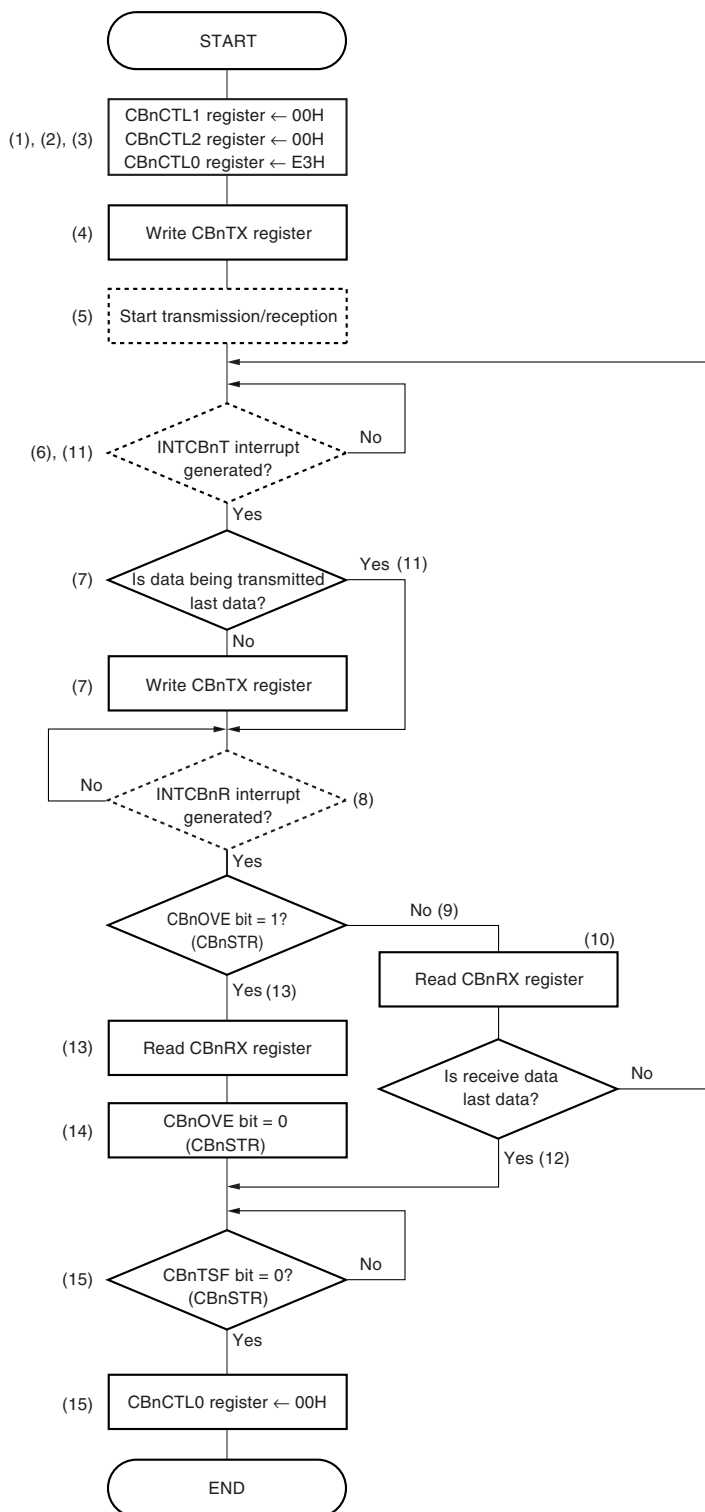

- Remarks**
1. The broken lines indicate the hardware processing.
  2. The numbers in this figure correspond to the processing numbers in (2) Operation timing.
  3. n = 0 to 5

## (2) Operation timing

(1/2)

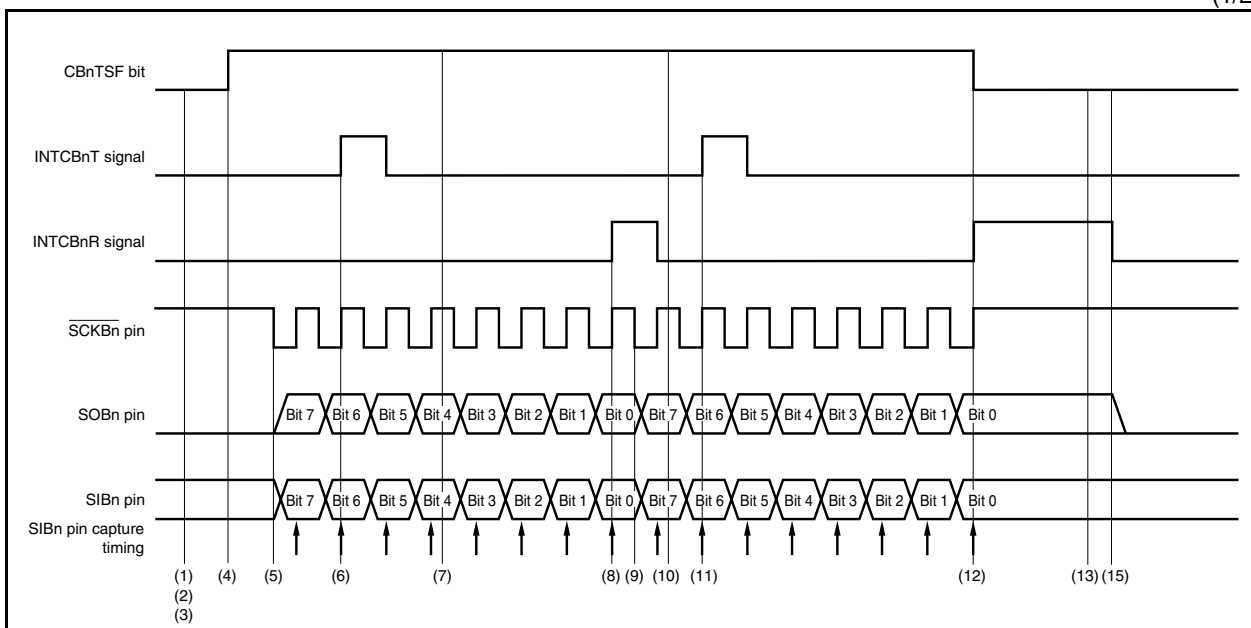

- (1) Write 00H to the CBnCTL1 register, and select communication type 1, communication clock ( $f_{\text{CLK}}$ ) =  $f_{\text{XP}}/2$ , and master mode.
- (2) Write 00H to the CBnCTL2 register, and set the transfer data length to 8 bits.
- (3) Write E3H to the CBnCTL0 register, and select the transmission/reception mode, MSB first, and continuous transfer mode at the same time as enabling the operation of the communication clock ( $f_{\text{CLK}}$ ).
- (4) The CBnSTR.CBnTSF bit is set to 1 by writing the transmit data to the CBnTX register, and transmission/reception is started.
- (5) When transmission/reception is started, output the serial clock to the SCKBn pin, output the transmit data to the SOBn pin in synchronization with the serial clock, and capture the receive data of the SIBn pin.
- (6) When transfer of the transmit data from the CBnTX register to the shift register is completed and writing to the CBnTX register is enabled, the transmission enable interrupt request signal (INTCBnT) is generated.
- (7) To continue transmission/reception, write the transmit data to the CBnTX register again after the INTCBnT signal is generated.
- (8) When one transmission/reception is completed, the reception completion interrupt request signal (INTCBnR) is generated, and reading of the CBnRX register is enabled.

**Remarks 1.**  $n = 0$  to 5

2.  $f_{\text{XP}}$ : Peripheral clock frequency (Prescaler 1 input clock frequency)

In clock mode 1,  $f_{\text{XP}} = f_{\text{XX}}$

In clock mode 2,  $f_{\text{XP}} = f_{\text{XPLL}}/2$  (14.64 to 16 MHz)

In clock mode 3,  $f_{\text{XP}} = f_{\text{XPLL}}$  (29.28 to 32 MHz)

In clock mode 4,  $f_{\text{XP}} = f_{\text{XPLL}}/2$  (20.88 to 24 MHz)

$f_{\text{XX}}$ : Main clock frequency

$f_{\text{XPLL}}$ : PLL output clock frequency for peripheral clock

- (9) When a new transmit data is written to the CBnTX register before communication completion, the next communication is started following communication completion.
- (10) Read the CBnRX register.
- (11) The transfer of the transmit data from the CBnTX register to the shift register is completed and the INTCBnT signal is generated. To end continuous transmission/reception with the current transmission/reception, do not write to the CBnTX register.
- (12) When the next transmit data is not written to the CBnTX register before transfer completion, stop the serial clock output to the  $\overline{\text{SCKBn}}$  pin after transfer completion, and clear the CBnTSF bit to 0.
- (13) When the reception error interrupt request signal (INTCBnR) is generated, read the CBnRX register.
- (14) If an overrun error occurs, write the CBnSTR.CBnOVE bit = 0, and clear the error flag.
- (15) To release the transmission/reception enable status, write the CBnCTL0.CBnPWR bit = 0, the CBnCTL0.CBnTXE bit = 0, and the CBnCTL0.CBnRXE bit = 0 after checking that the CBnTSF bit = 0.

**Remark** n = 0 to 5

**17.6.10 Continuous transfer mode (slave mode, transmission mode)**

MSB first (CBnCTL0.CBnDIR bit = 0), communication type 1 (CBnCTL1.CBnCKP and CBnCTL1.CBnDAP bits = 00), communication clock (f<sub>CLK</sub>) = external clock (SCKBn) (CBnCTL1.CBnCKS2 to CBnCTL1.CBnCKS0 bits = 111), transfer data length = 8 bits (CBnCTL2.CBnCL3 to CBnCTL2.CBnCL0 bits = 0000)

**(1) Operation flow**

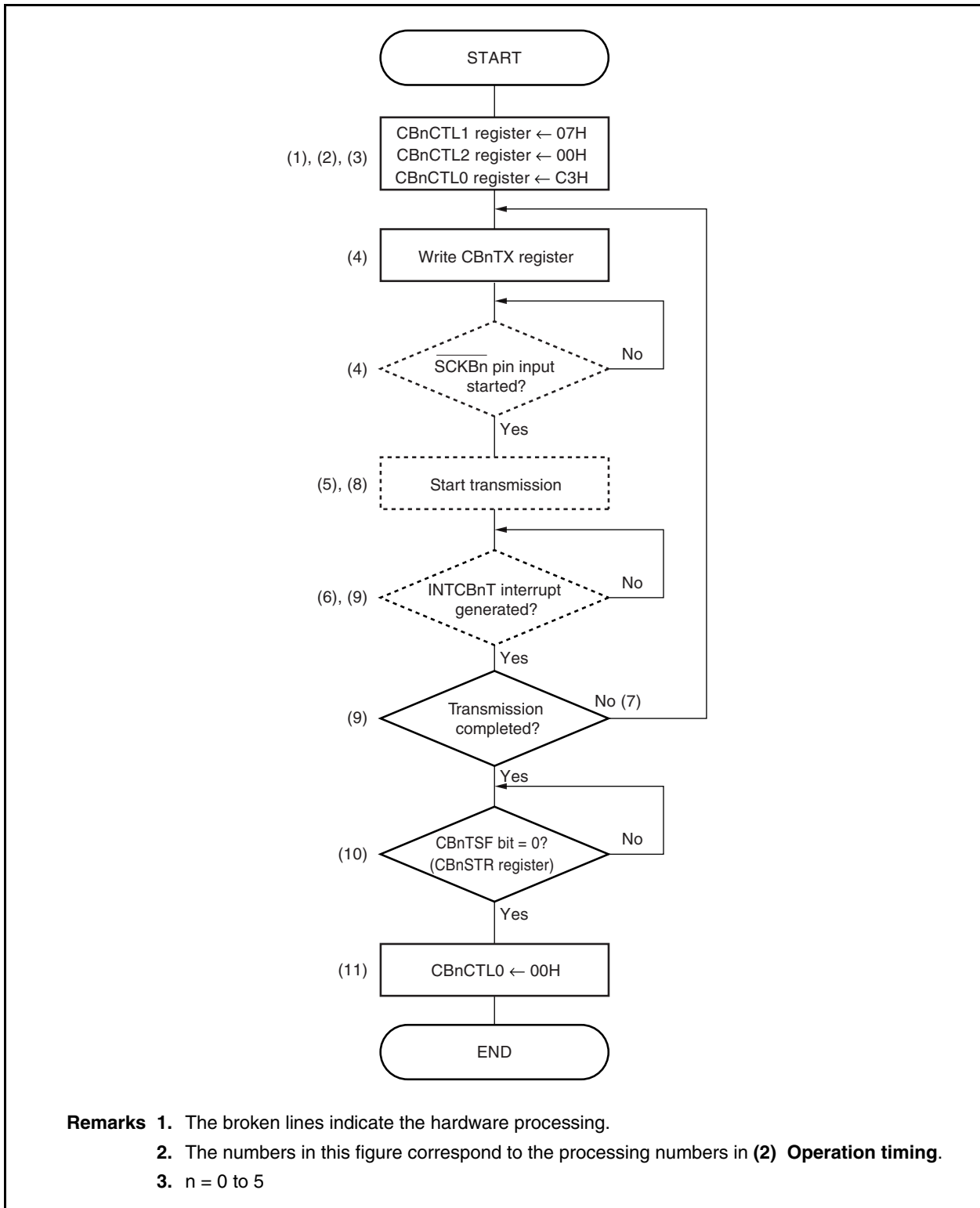

- Remarks**
1. The broken lines indicate the hardware processing.
  2. The numbers in this figure correspond to the processing numbers in **(2) Operation timing**.
  3. n = 0 to 5

## (2) Operation timing

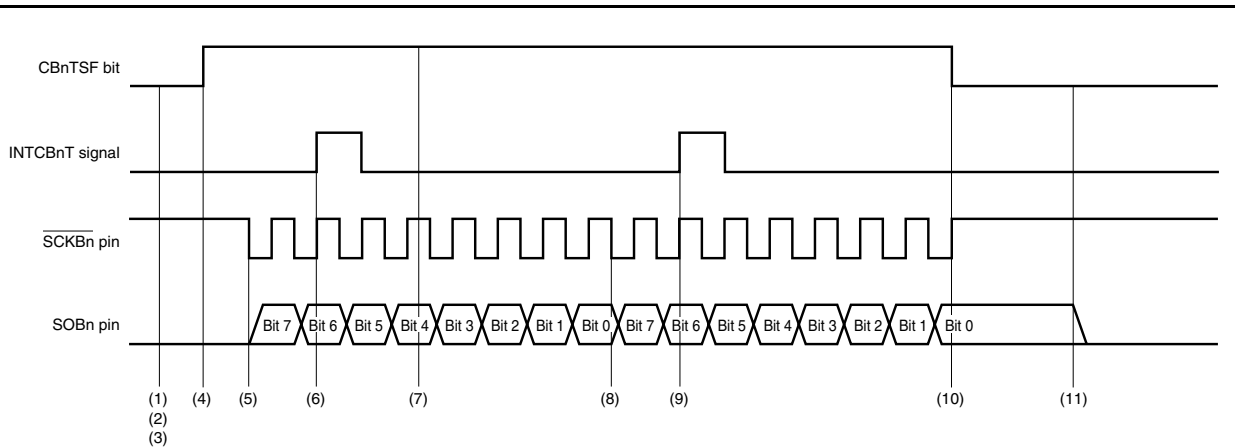

- (1) Write 07H to the `CBnCTL1` register, and select communication type 1, communication clock ( $f_{\text{CCLK}}$ ) = external clock (`SCKBn`), and slave mode.
- (2) Write 00H to the `CBnCTL2` register, and set the transfer data length to 8 bits.
- (3) Write C3H to the `CBnCTL0` register, and select the transmission mode, MSB first, and continuous transfer mode at the same time as enabling the operation of the communication clock ( $f_{\text{CCLK}}$ ).
- (4) The `CBnSTR.CBnTSF` bit is set to 1 by writing the transmit data to the `CBnTX` register, and the device waits for a serial clock input.
- (5) When a serial clock is input, output the transmit data from the `SOBn` pin in synchronization with the serial clock.
- (6) When transfer of the transmit data from the `CBnTX` register to the shift register is completed and writing to the `CBnTX` register is enabled, the transmission enable interrupt request signal (`INTCBnT`) is generated.
- (7) To continue transmission, write the transmit data to the `CBnTX` register again after the `INTCBnT` signal is generated.
- (8) When a serial clock is input following completion of the transmission of the transfer data length set with the `CBnCTL2` register, continuous transmission is started.
- (9) When transfer of the transmit data from the `CBnTX` register to the shift register is completed and writing to the `CBnTX` register is enabled, the `INTCBnT` signal is generated. To end continuous transmission with the current transmission, do not write to the `CBnTX` register.
- (10) When the clock of the transfer data length set with the `CBnCTL2` register is input without writing to the `CBnTX` register, clear the `CBnTSF` bit to 0 to end transmission.
- (11) To release the transmission enable status, write the `CBnCTL0.CBnPWR` bit = 0 and the `CBnCTL0.CBnTXE` bit = 0 after checking that the `CBnTSF` bit = 0.

**Caution** In continuous transmission mode, the reception completion interrupt request signal (`INTCBnR`) is not generated.

**Remark**  $n = 0$  to 5



**17.6.11 Continuous transfer mode (slave mode, reception mode)**

MSB first (CBnCTL0.CBnDIR bit = 0), communication type 1 (CBnCTL1.CBnCKP and CBnCTL1.CBnDAP bits = 00), communication clock ( $f_{\text{CLK}}$ ) = external clock ( $\overline{\text{SCKBn}}$ ) (CBnCTL1.CBnCKS2 to CBnCTL1.CBnCKS0 bits = 111), transfer data length = 8 bits (CBnCTL2.CBnCL3 to CBnCTL2.CBnCL0 bits = 0000)

(1) Operation flow

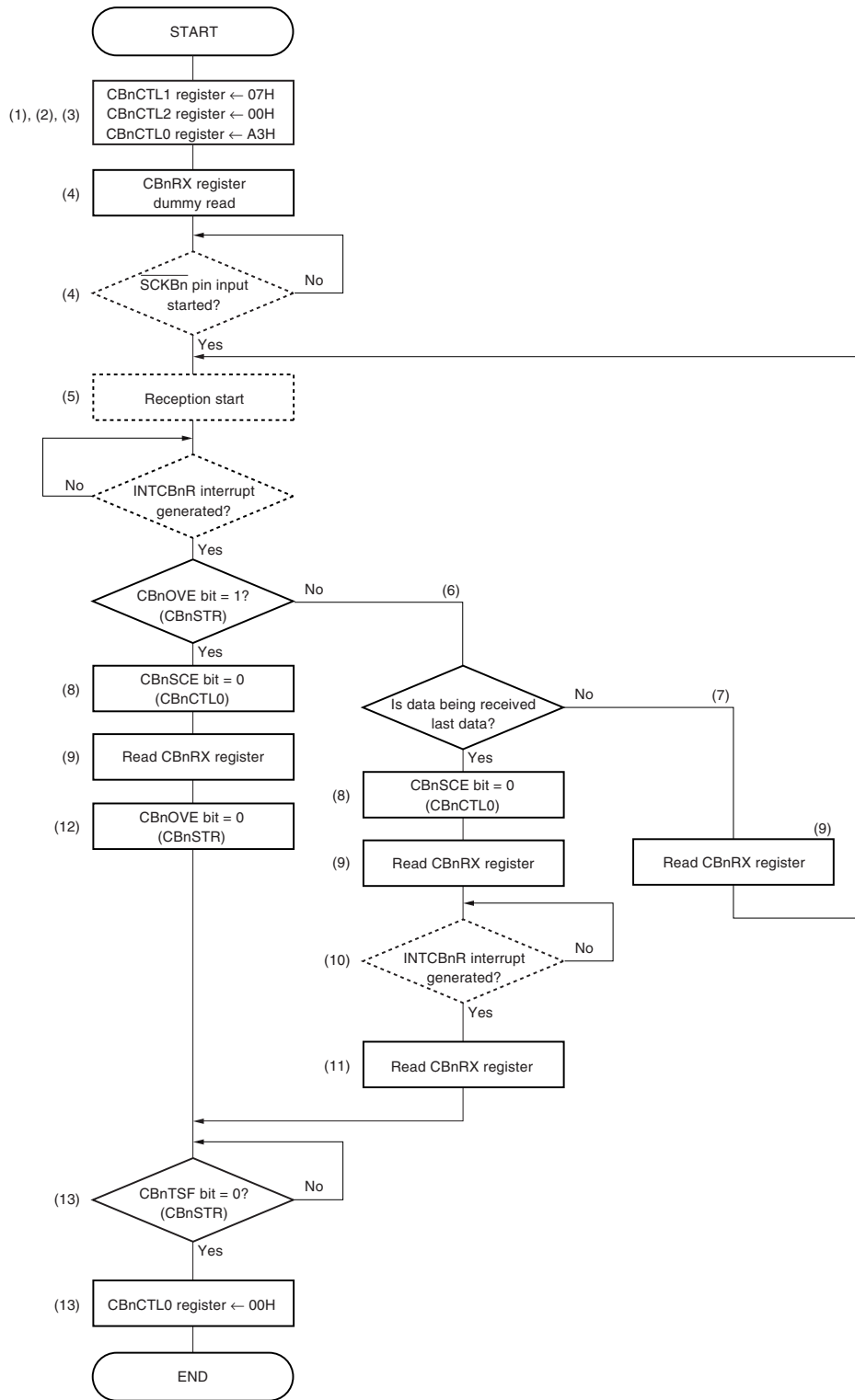

- Remarks**
1. The broken lines indicate the hardware processing.
  2. The numbers in this figure correspond to the processing numbers in (2) **Operation timing**.
  3. n = 0 to 5

## (2) Operation timing

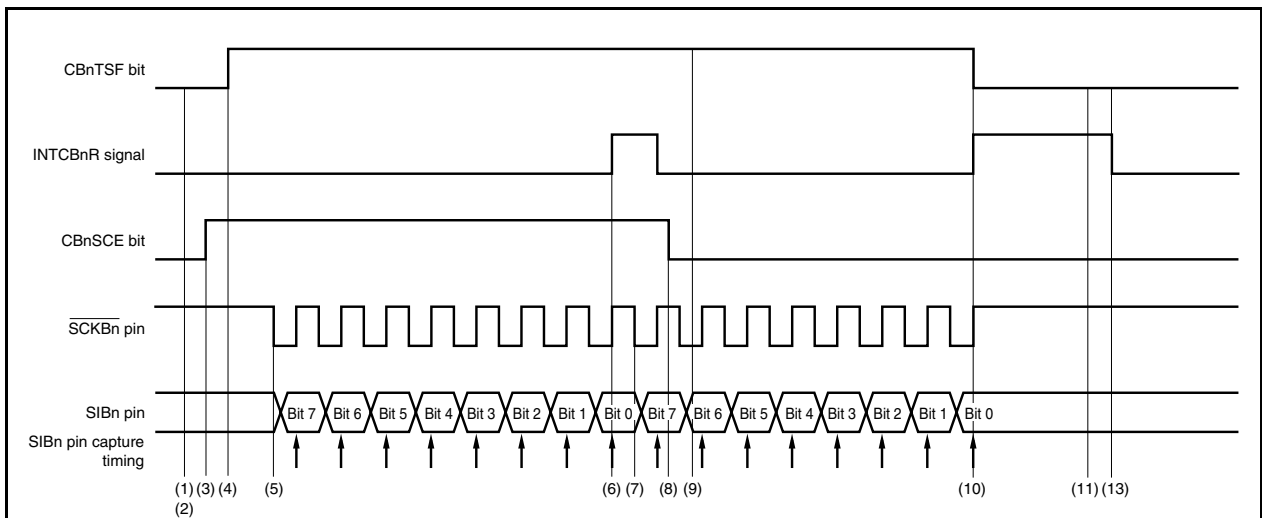

- (1) Write 07H to the CBnCTL1 register, and select communication type 1, communication clock ( $f_{\text{CLK}}$ ) = external clock ( $\overline{\text{SCKBn}}$ ), and slave mode.
- (2) Write 00H to the CBnCTL2 register, and set the transfer data length to 8 bits.
- (3) Write A3H to the CBnCTL0 register, and select the reception mode, MSB first, and continuous transfer mode at the same time as enabling the operation of the communication clock ( $f_{\text{CLK}}$ ).
- (4) The CBnSTR.CBnTSF bit is set to 1 by performing a dummy read of the CBnRX register, and the device waits for a serial clock input.
- (5) When a serial clock is input, capture the receive data of the SIBn pin in synchronization with the serial clock.
- (6) When reception is completed, the reception completion interrupt request signal (INTCBnR) is generated, and reading of the CBnRX register is enabled.
- (7) When a serial clock is input in the CBnCTL0.CBnSCE bit = 1 status, continuous reception is started.
- (8) To end continuous reception with the current reception, write the CBnSCE bit = 0.
- (9) Read the CBnRX register.
- (10) When reception is completed, the INTCBnR signal is generated, and reading of the CBnRX register is enabled. When the CBnSCE bit = 0 is set before communication completion, clear the CBnTSF bit to 0 to end the receive operation.
- (11) Read the CBnRX register.
- (12) If an overrun error occurs, write the CBnSTR.CBnOVE bit = 0, and clear the error flag.
- (13) To release the reception enable status, write the CBnCTL0.CBnPWR bit = 0 and the CBnCTL0.CBnRXE bit = 0 after checking that the CBnTSF bit = 0.

**Remark** n = 0 to 5

**17.6.12 Continuous transfer mode (slave mode, transmission/reception mode)**

MSB first (CBnCTL0.CBnDIR bit = 0), communication type 1 (CBnCTL1.CBnCKP and CBnCTL1.CBnDAP bits = 00), communication clock (f<sub>CCLK</sub>) = external clock ( $\overline{\text{SCKBn}}$ ) (CBnCTL1.CBnCKS2 to CBnCTL1.CBnCKS0 bits = 111), transfer data length = 8 bits (CBnCTL2.CBnCL3 to CBnCTL2.CBnCL0 bits = 0000)

(1) Operation flow

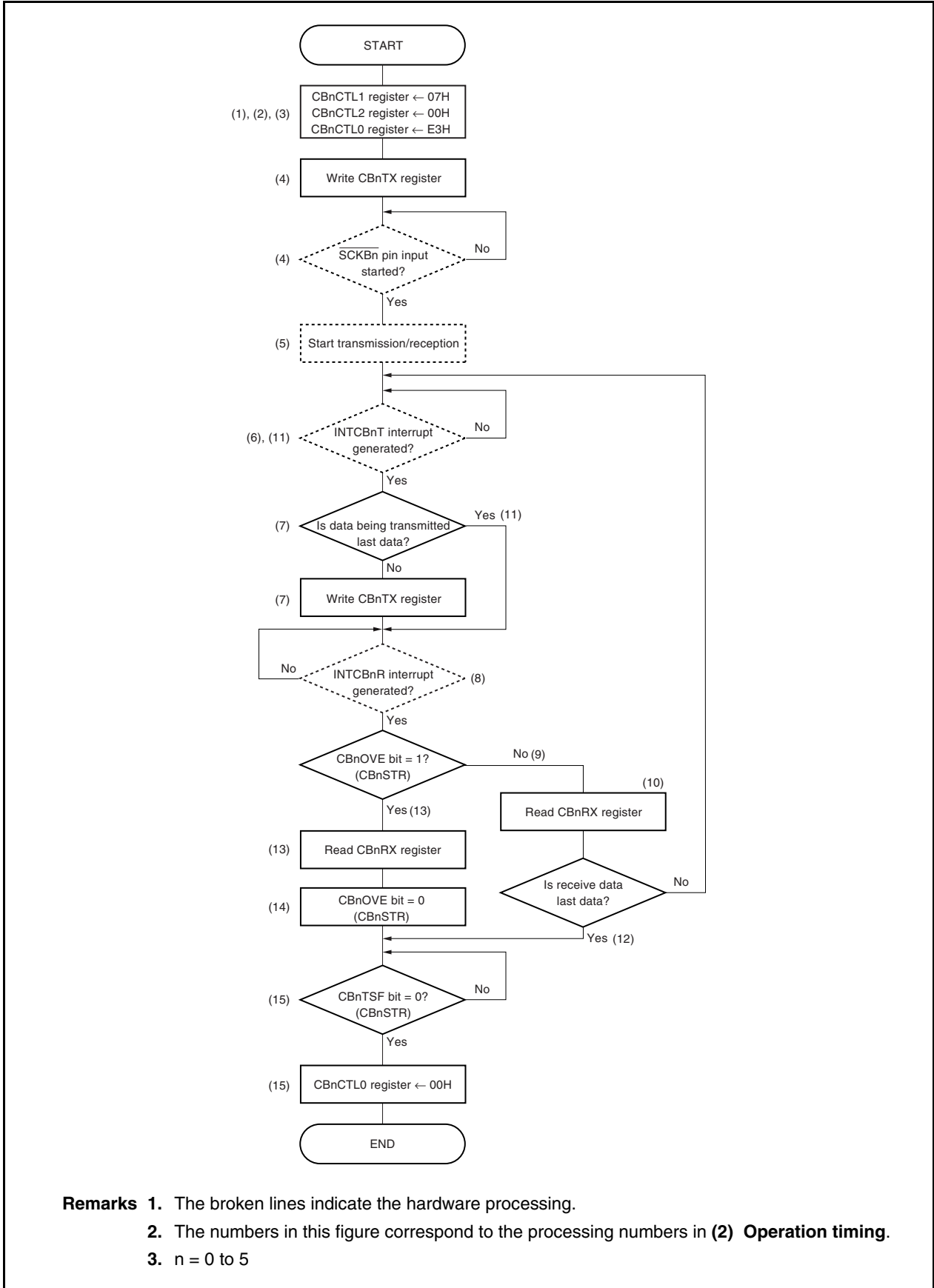

- Remarks**
1. The broken lines indicate the hardware processing.
  2. The numbers in this figure correspond to the processing numbers in (2) **Operation timing**.
  3. n = 0 to 5

## (2) Operation timing

(1/2)

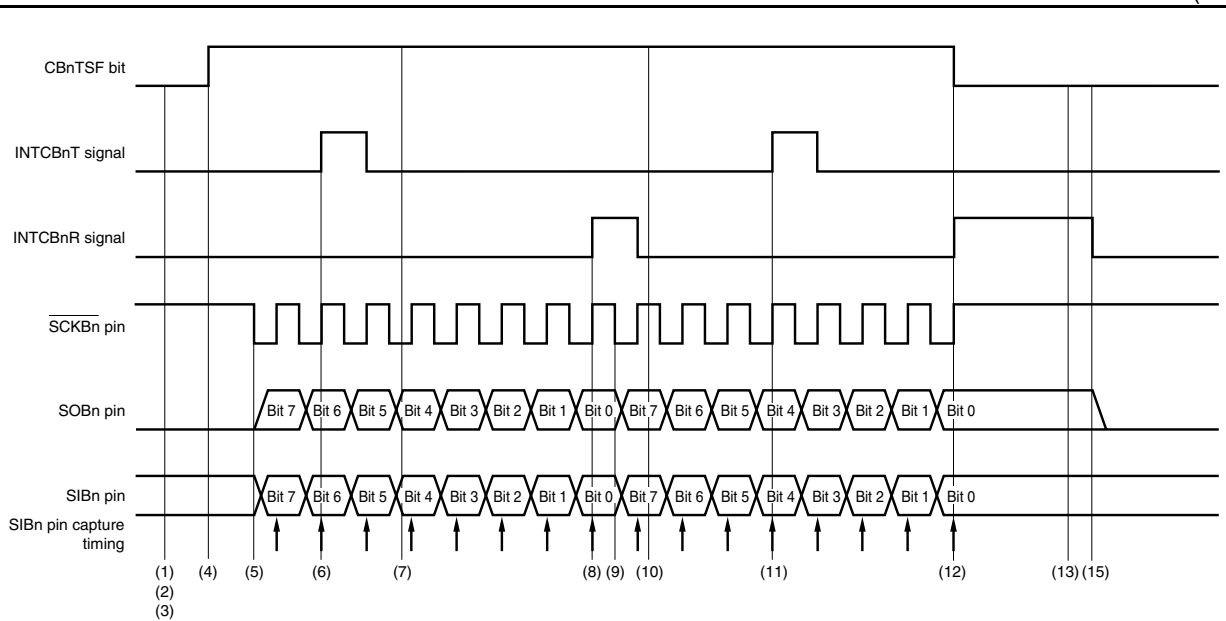

- (1) Write 07H to the `CBnCTL1` register, and select communication type 1, communication clock ( $f_{CCLK}$ ) = external clock (SCKBn), and slave mode.
- (2) Write 00H to the `CBnCTL2` register, and set the transfer data length to 8 bits.
- (3) Write E3H to the `CBnCTL0` register, and select the transmission/reception mode, MSB first, and continuous transfer mode at the same time as enabling the operation of the communication clock ( $f_{CCLK}$ ).
- (4) The `CBnSTR.CBnTnSF` bit is set to 1 by writing the transmit data to the `CBnTX` register, and the device waits for a serial clock input.
- (5) When a serial clock is input, output the transmit data to the SOBn pin in synchronization with the serial clock, and capture the receive data of the SIBn pin.
- (6) When transfer of the transmit data from the `CBnTX` register to the shift register is completed and writing to the `CBnTX` register is enabled, the transmission enable interrupt request signal (INTCBnT) is generated.
- (7) To continue transmission, write the transmit data to the `CBnTX` register again after the INTCBnT signal is generated.
- (8) When reception of the transfer data length set with the `CBnCTL2` register is completed, the reception completion interrupt request signal (INTCBnR) is generated, and reading of the `CBnRX` register is enabled.
- (9) When a serial clock is input continuously, continuous transmission/reception is started.
- (10) Read the `CBnRX` register.
- (11) When transfer of the transmit data from the `CBnTX` register to the shift register is completed and writing to the `CBnTX` register is enabled, the INTCBnT signal is generated. To end continuous transmission/reception with the current transmission/reception, do not write to the `CBnTX` register.

**Remark** n = 0 to 5

- (12) When the clock of the transfer data length set with the CBnCTL2 register is input without writing to the CBnTX register, the INTCBnR signal is generated. Clear the CBnTSF bit to 0 to end transmission/reception.
- (13) When the INTCBnR signal is generated, read the CBnRX register.
- (14) If an overrun error occurs, write the CBnSTR.CBnOVE bit = 0, and clear the error flag.
- (15) To release the transmission/reception enable status, write the CBnCTL0.CBnPWR bit = 0, the CBnCTL0.CBnTXE bit = 0, and the CBnCTL0.CBnRXE bit = 0 after checking that the CBnTSF bit = 0.

**Remark** n = 0 to 5

### 17.6.13 Reception error

When transfer is performed with reception enabled (CBnCTL0.CBnRXE bit = 1) in the continuous transfer mode, the reception completion interrupt request signal (INTCBnR) is generated again when the next receive operation is completed before the CBnRX register is read after the INTCBnR signal is generated, and the overrun error flag (CBnSTR.CBnOVE) is set to 1.

Even if an overrun error has occurred, the previous receive data is lost since the CBnRX register is updated. Even if a reception error has occurred, the INTCBnR signal is generated again upon the next reception completion if the CBnRX register is not read.

To avoid an overrun error, complete reading the CBnRX register until one half clock before sampling the last bit of the next receive data from the INTCBnR signal generation.

#### (1) Operation timing

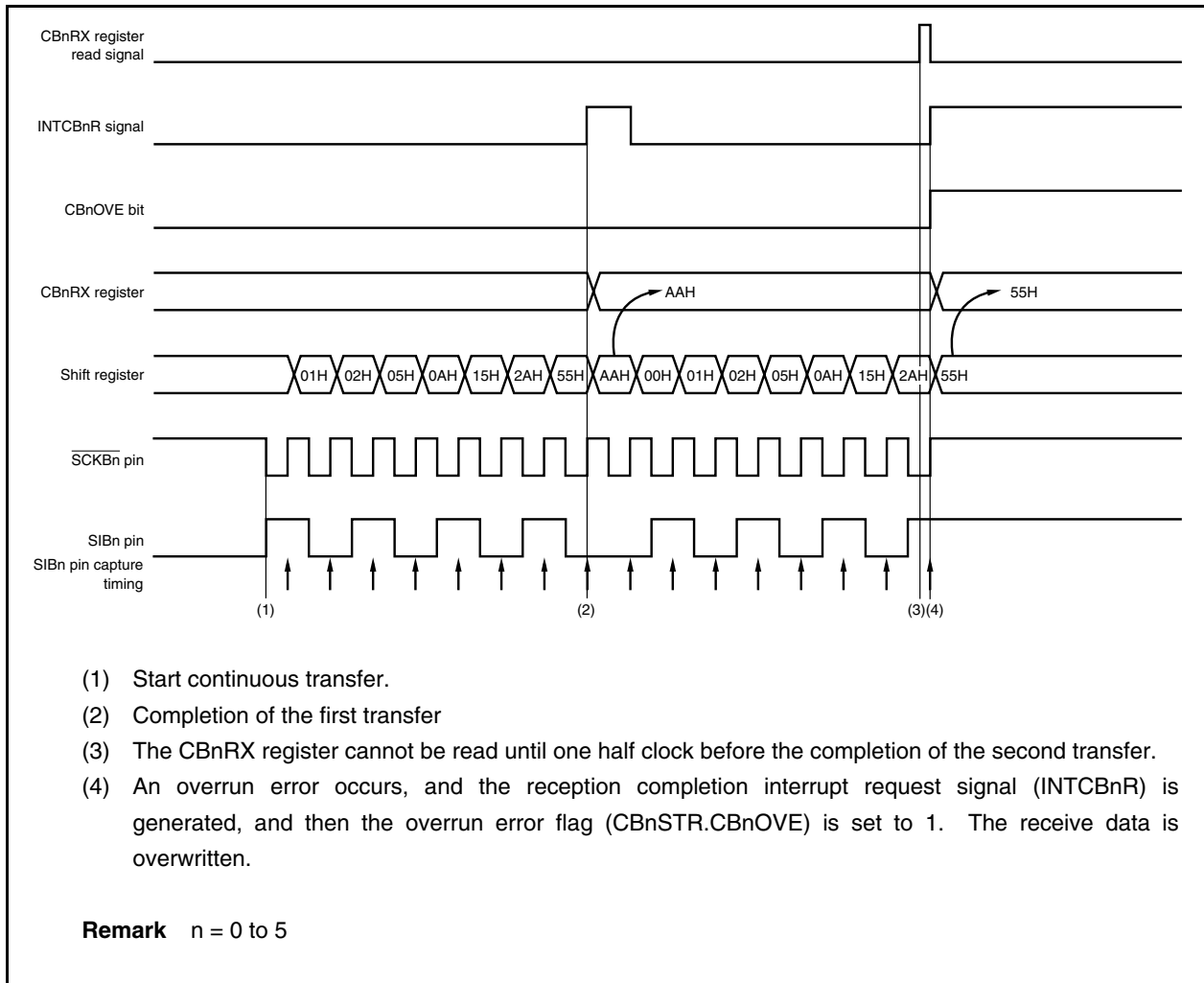



## 17.6.14 Clock timing

(1/2)

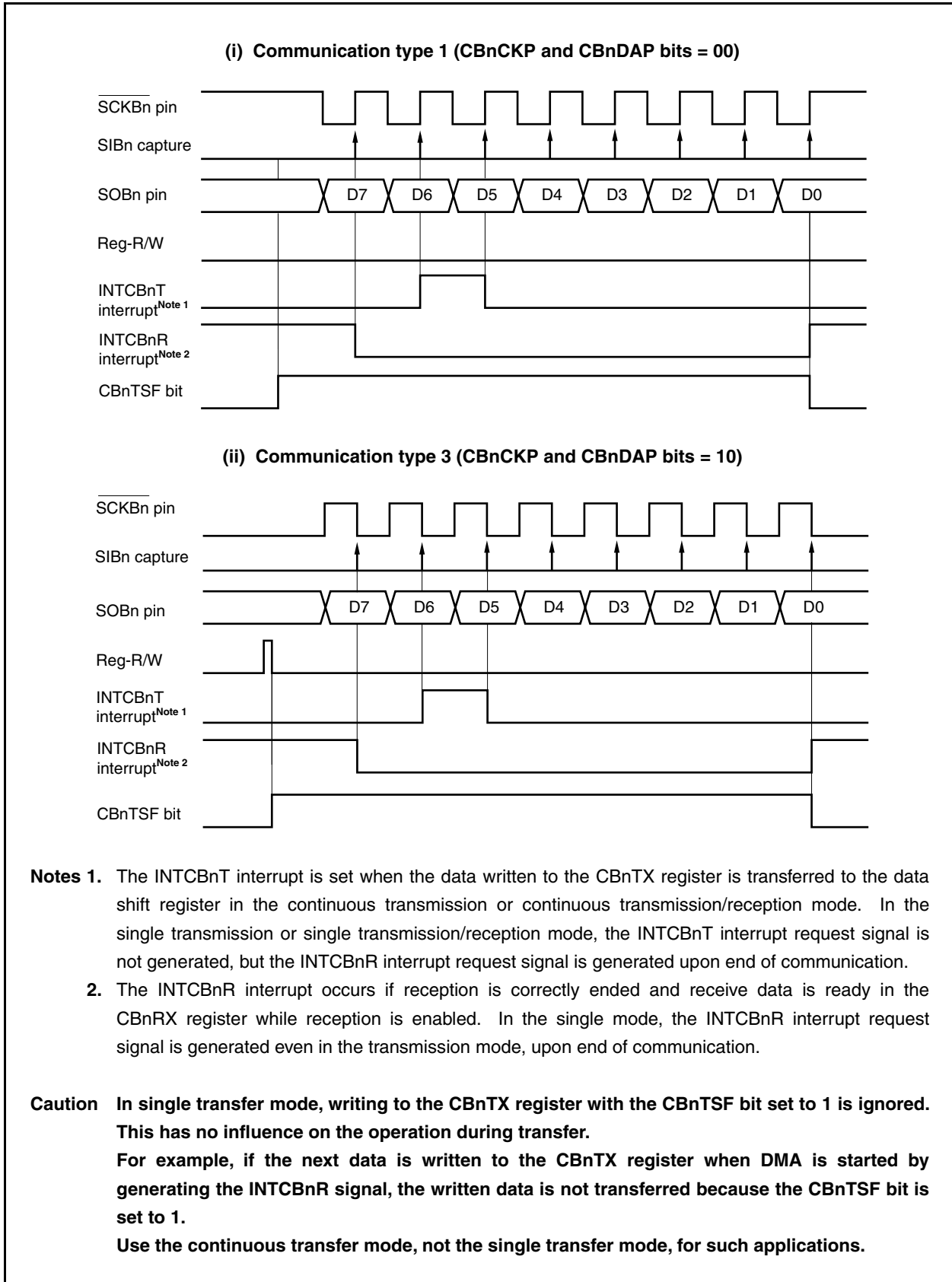

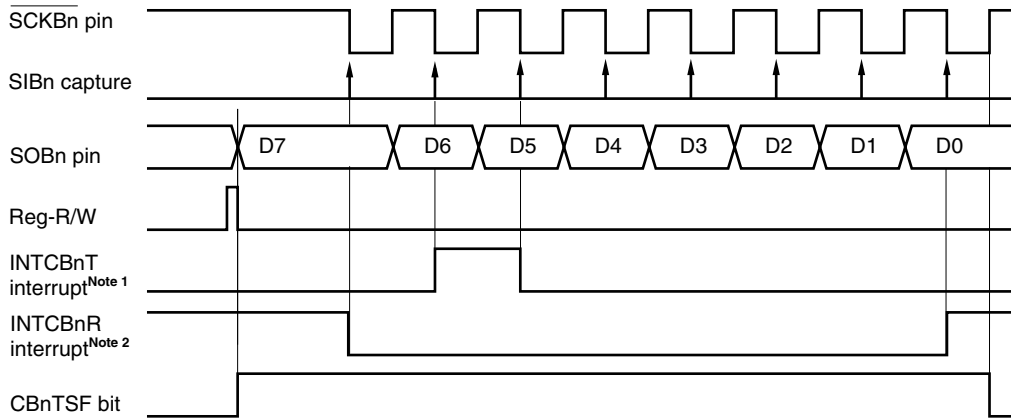
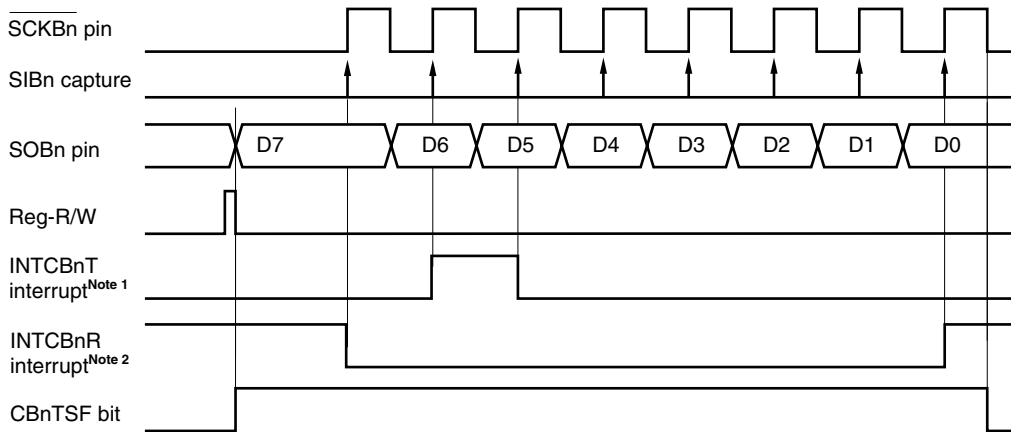
**(iii) Communication type 2 (CBnCKP and CBnDAP bits = 01)****(iv) Communication type 4 (CBnCKP and CBnDAP bits = 11)**

- Notes 1.** The INTCBnT interrupt is set when the data written to the CBnTX register is transferred to the data shift register in the continuous transmission or continuous transmission/reception modes. In the single transmission or single transmission/reception modes, the INTCBnT interrupt request signal is not generated, but the INTCBnR interrupt request signal is generated upon end of communication.
- 2.** The INTCBnR interrupt occurs if reception is correctly ended and receive data is ready in the CBnRX register while reception is enabled. In the single mode, the INTCBnR interrupt request signal is generated even in the transmission mode, upon end of communication.

**Caution** In single transfer mode, writing to the CBnTX register with the CBnTSF bit set to 1 is ignored. This has no influence on the operation during transfer.

For example, if the next data is written to the CBnTX register when DMA is started by generating the INTCBnR signal, the written data is not transferred because the CBnTSF bit is set to 1.

Use the continuous transfer mode, not the single transfer mode, for such applications.

## 17.7 Output Pins

### (1) $\overline{\text{SCKBn}}$ pin

When CSIBn operation is disabled (CBnCTL0.CBnPWR bit = 0), the  $\overline{\text{SCKBn}}$  pin output status is as follows.

CBnCKP	CBnCKS2	CBnCKS1	CBnCKS0	$\overline{\text{SCKBn}}$ Pin Output
0	1	1	1	High impedance
	Other than above			Fixed to high level
1	1	1	1	High impedance
	Other than above			Fixed to low level

**Remarks 1.** The output level of the  $\overline{\text{SCKBn}}$  pin changes if any of the CBnCTL1.CBnCKP and CBnCKS2 to CBnCKS0 bits is rewritten.

**2.** n = 0 to 5

### (2) SOBn pin

When CSIBn operation is disabled (CBnPWR bit = 0), the SOBn pin output status is as follows.

CBnTXE	CBnDAP	CBnDIR	SOBn Pin Output
0	×	×	Fixed to low level
1	0	×	SOBn latch value (low level)
	1	0	CBnTX value (MSB)
		1	CBnTX value (LSB)

**Remarks 1.** The SOBn pin output changes when any one of the CBnCTL0.CBnTXE, CBnCTL0.CBnDIR bits, and CBnCTL1.CBnDAP bit is rewritten.

**2.** ×: Don't care

**3.** n = 0 to 5

## 17.8 Baud Rate Generator

The BRG1 to BRG3 and CSIB0 to CSIB5 baud rate generators are connected as shown in the following block diagram.

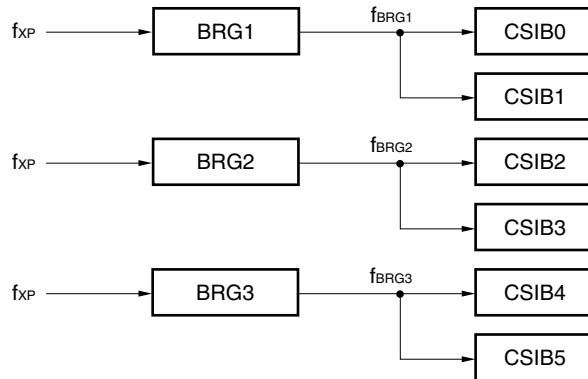

**Remark**  $f_{XP}$ : Peripheral clock frequency (Prescaler 1 input clock frequency)

In clock mode 1,  $f_{XP} = f_{XX}$

In clock mode 2,  $f_{XP} = f_{XMPLL}/2$  (14.64 to 16 MHz)

In clock mode 3,  $f_{XP} = f_{XMPLL}$  (29.28 to 32 MHz)

In clock mode 4,  $f_{XP} = f_{XMPLL}/2$  (20.88 to 24 MHz)

$f_{XX}$ : Main clock frequency

$f_{XMPLL}$ : PLL output clock frequency for peripheral clock

**(1) BRGm prescaler mode registers (PRSMm)**

The PRSM1 to PRSM3 registers control generation of the baud rate signal for CSIB.

These registers can be read or written in 8-bit or 1-bit units.

Reset sets these registers to 00H.

After reset: 00H    R/W    Address: PRSM1 FFFF320H, PRSM2 FFFF324H, PRSM3 FFFF328H

	7	6	5	<4>	3	2	1	0
PRSMm (m = 1 to 3)	0	0	0	BGCEm	0	0	BGCSm1	BGCSm0

BGCEm	Baud rate output
0	Disabled
1	Enabled

BGCSm1	BGCSm0	Input clock selection ( $f_{BGCSm}$ )	Setting value (k)
0	0	$f_{XP}$	0
0	1	$f_{XP}/2$	1
1	0	$f_{XP}/4$	2
1	1	$f_{XP}/8$	3

- Cautions**
1. Do not rewrite the PRSMm register during operation.
  2. Set the PRSMm register before setting the BGCEm bit to 1.
  3. Be sure to set bits 2, 3, and 5 to 7 to “0”.

**Remark**  $f_{XP}$ : Peripheral clock frequency (Prescaler 1 input clock frequency)  
 In clock mode 1,  $f_{XP} = f_{XX}$   
 In clock mode 2,  $f_{XP} = f_{XMPLL}/2$  (14.64 to 16 MHz)  
 In clock mode 3,  $f_{XP} = f_{XMPLL}$  (29.28 to 32 MHz)  
 In clock mode 4,  $f_{XP} = f_{XMPLL}/2$  (20.88 to 24 MHz)  
 $f_{XX}$ : Main clock frequency  
 $f_{XMPLL}$ : PLL output clock frequency for peripheral clock

**(2) BRGm prescaler compare registers (PRSCMm)**

The PRSCM1 to PRSCM3 registers are 8-bit compare registers.

These registers can be read or written in 8-bit units.

Reset sets these registers to 00H.

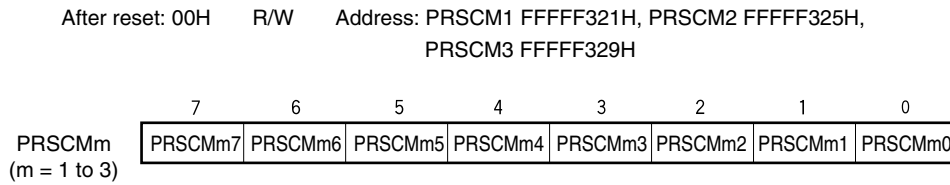

- Cautions**
1. Do not rewrite the PRSCMm register during operation.
  2. Set the PRSCMm register before setting the PRSMm.BGCEm bit to 1.

**17.8.1 Baud rate generation**

The transmission/reception clock is generated by dividing the main clock. The baud rate generated from the main clock is obtained by the following equation.

$$f_{BRGm} = \frac{f_{XP}}{2^{k+1} \times N}$$

**Caution** Set  $f_{BRGm}$  to 8 MHz or lower.

**Remark**  $f_{BRGm}$ : BRGm count clock

$f_{XP}$ : Peripheral clock frequency (Prescaler 1 input clock frequency)

In clock mode 1,  $f_{XP} = f_{XX}$

In clock mode 2,  $f_{XP} = f_{XMPLL}/2$  (14.64 to 16 MHz)

In clock mode 3,  $f_{XP} = f_{XMPLL}$  (29.28 to 32 MHz)

In clock mode 4,  $f_{XP} = f_{XMPLL}/2$  (20.88 to 24 MHz)

$f_{XX}$ : Main clock frequency

$f_{XMPLL}$ : PLL output clock frequency for peripheral clock

k: PRSMm register setting value = 0 to 3

N: PRSCMm register setting value = 1 to 256

However,  $N = 256$  only when PRSCMm register is set to 00H.

m = 1 to 3

## 17.9 Cautions

- (1) When transferring transmit data and receive data using DMA transfer, error processing cannot be performed even if an overrun error occurs during serial transfer. Check that the no overrun error has occurred by reading the CBnSTR.CBnOVE bit after DMA transfer has been completed.
- (2) In regards to registers that are forbidden from being rewritten during operations (CBnCTL0.CBnPWR bit is 1), if rewriting has been carried out by mistake during operations, set the CBnCTL0.CBnPWR bit to 0 once, then initialize CSIBn.

Registers to which rewriting during operation are prohibited are shown below.

- CBnCTL0 register: CBnTXE, CBnRXE, CBnDIR, CBnTMS bits
- CBnCTL1 register: CBnCKP, CBnDAP, CBnCKS2 to CBnCKS0 bits
- CBnCTL2 register: CBnCL3 to CBnCL0 bits

- (3) In communication type 2 and 4 (CBnCTL1.CBnDAP bit = 1), the CBnSTR.CBnTSF bit is cleared half a  $\overline{\text{SCKBn}}$  clock after occurrence of a reception completion interrupt (INTCBnR).

In the single transfer mode, writing the next transmit data is ignored during communication (CBnTSF bit = 1), and the next communication is not started. Also if reception-only communication (CBnCTL0.CBnTXE bit = 0, CBnCTL0.CBnRXE bit = 1) is set, the next communication is not started even if the receive data is read during communication (CBnTSF bit = 1).

Therefore, when using the single transfer mode with communication type 2 or 4 (CBnDAP bit = 1), pay particular attention to the following.

- To start the next transmission, confirm that CBnTSF bit = 0 and then write the transmit data to the CBnTX register.
- To perform the next reception continuously when reception-only communication (CBnTXE bit = 0, CBnRXE bit = 1) is set, confirm that CBnTSF bit = 0 and then read the CBnRX register.

Or, use the continuous transfer mode instead of the single transfer mode. Use of the continuous transfer mode is recommended especially when using DMA.

**Remark** n = 0 to 5

## CHAPTER 18 3-WIRE VARIABLE-LENGTH SERIAL I/O E (CSIE)

The V850E/SJ3-H and V850E/SK3-H provide a clocked serial interface called 3-wire variable-length serial I/O E (CSIE). The number of channels differs depending on the product in the V850E/SJ3-H and V850E/SK3-H as shown in the table below.

<R> **Table 18-1. Number of Channels Available for 3-Wire Variable-Length Serial I/O E (CSIE)**

Product Name	V850E/SJ3-H		V850E/SK3-H
	$\mu$ PD70F3931, 70F3932, and 70F3933 only	Other than $\mu$ PD70F3931, 70F3932, and 70F3933	
Channel	0 channels		2 channels

### 18.1 Port Setting of CSIE0 and CSIE1

<R> **18.1.1 V850E/SJ3-H (other than  $\mu$ PD70F3931, 70F3932, 70F3933)**

**Table 18-2. Pin Configuration**

Mode	Pin Name	Alternate-Function Pin					
		Port <1>			Port <2>		
		Pin No.	Port	Alternate Function	Pin No.	Port	Alternate Function
CSIE0	SIE0	43	P60	RTP10/RXDA4	–	–	–
	SOE0	44	P61	RTP11/TXDA4	–	–	–
	$\overline{\text{SCKE0}}$	45	P62	RTP12	–	–	–
CSIE1	SIE1	46	P63	RTP13/KR4	–	–	–
	SOE1	47	P64	RTP14/KR5	–	–	–
	$\overline{\text{SCKE1}}$	48	P65	RTP15/KR2/TIQ03/TOQ03	–	–	–

#### (1) CSIE0

The serial reception data/serial transmission data/serial clock pins (SIE0, SOE0, and  $\overline{\text{SCKE0}}$ ) of CSIE0 are assigned to P60 to P62, respectively. When using CSIE0, specify P60 to P62 as the SIE0, SOE0, and  $\overline{\text{SCKE0}}$  pins in advance, using the PMC6, PFC6, and PFCE6 registers.

The SIE0, SOE0, and  $\overline{\text{SCKE0}}$  pins function alternately as the pins (RXDA4 and TXDA4) of UARTA4 as well as the real-time output pins (RTP10, RTP11, and RTP12); therefore, they cannot be used at the same time.

#### (2) CSIE1

The serial reception data/serial transmission data/serial clock pins (SIE1, SOE1, and  $\overline{\text{SCKE1}}$ ) of CSIE1 are assigned to P63 to P65, respectively. When using CSIE1, specify P63 to P65 as the SIE1, SOE1, and  $\overline{\text{SCKE1}}$  pins in advance, using the PMC6, PFC6, and PFCE6 registers.

The SIE1, SOE1, and  $\overline{\text{SCKE1}}$  pins function alternately as the real-time output pins (RTP13, RTP14, RTP15) and they cannot be used at the same time. The SIE1, SOE1, and  $\overline{\text{SCKE1}}$  pins function alternately as the key interrupt input pins (KR4, KR5, and KR2), as well as the TMQ0 I/O pins (TIQ03 and TOQ03), therefore, when using them at the same time, use the pins assigned to the other port (KR4:P54, KR5:P55, KR2/TIQ03, and TOQ03:P52).



&lt;R&gt;

- Cautions 1.** The CSIE0 and CSIE1 functions are not included in the  $\mu$ PD70F3931, 70F3932, and 70F3933.
- 2.** Do not switch port settings during operation. Be sure to disable operation of the unit which does not perform the port setting and is not being used.

## 18.1.2 V850E/SK3-H

Table 18-3. Pin Configuration

Mode	Pin Name	Alternate-Function Pin					
		Port <1>			Port <2>		
		Pin No.	Port	Alternate Function	Pin No.	Port	Alternate Function
CSIE0	SIE0	53	P60	RTP10/RXDA4	–	–	–
	SOE0	54	P61	RTP11/TXDA4	–	–	–
	$\overline{\text{SCKE0}}$	55	P62	RTP12	–	–	–
CSIE1	SIE1	56	P63	RTP13/KR4	–	–	–
	SOE1	57	P64	RTP14/KR5	–	–	–
	$\overline{\text{SCKE1}}$	58	P65	RTP15/KR2/TIQ03/TOQ03	–	–	–

**(1) CSIE0**

The serial reception data/serial transmission data/serial clock pins (SIE0, SOE0, and  $\overline{\text{SCKE0}}$ ) of CSIE0 are assigned to P60 to P62, respectively. When using CSIE0, specify P60 to P62 as the SIE0, SOE0, and  $\overline{\text{SCKE0}}$  pins in advance, using the PMC6, PFC6, and PFCE6 registers.

The SIE0, SOE0 and  $\overline{\text{SCKE0}}$  pins function alternately as the real-time output pins (RTP10, RTP11, and RTP12), and they cannot be used at the same time. The SIE0 and SOE0 pins function alternately as the transmission/reception pins (RXDA4 and TXDA4) of UARTA4. When using them at the same time, therefore, use the pins assigned to the other port (P56 and P57).

**(2) CSIE1**

The serial reception data/serial transmission data/serial clock pins (SIE1, SOE1, and  $\overline{\text{SCKE1}}$ ) of CSIE1 are assigned to P63 to P65, respectively. When using CSIE1, specify P63 to P65 as the SIE1, SOE1, and  $\overline{\text{SCKE1}}$  pins in advance, using the PMC6, PFC6, and PFCE6 registers.

The SIE1, SOE1, and  $\overline{\text{SCKE1}}$  pins function alternately as the real-time output pins (RTP13, RTP14, RTP15) and they cannot be used at the same time. The SIE1, SOE1, and  $\overline{\text{SCKE1}}$  pins function alternately as the key interrupt input pins (KR4, KR5, and KR2), as well as the TMQ0 I/O pins (TIQ03 and TOQ03), therefore, when using them at the same time, use the pins assigned to the other port (KR4:P54, KR5:P55, KR2/TIQ03, and TOQ03:P52).

**Caution** Do not switch port settings during operation. Be sure to disable operation of the unit which does not perform the port setting and is not being used.

## 18.2 Features

- Transfer rate: 8 Mbps max.
- Master mode and slave mode selectable
- Transfer data length selectable in 1-bit units between 8 and 16 bits
- Transfer data MSB-first/LSB-first switchable
- Serial clock and data phase switchable
- Sixteen on-chip 16-bit transmission/reception buffers (CSIBUF<sub>n</sub>) available
- Transmission mode, reception mode, and transmission/reception mode specifiable
  - Transmission mode: Transmission is started by writing transmit data to the CSIE<sub>n</sub> transmit buffer register (CEnTX0) while transmission is enabled.
  - Reception mode: Reception is started by writing dummy data to the CSIE<sub>n</sub> transmit buffer register (CEnTX0) while reception is enabled.
  - Transmission/reception mode: Transmission/reception is started by writing transmit data to the CSIE<sub>n</sub> transmit buffer register (CEnTX0) while transmission/reception is enabled.
- Interrupt request signals
  - Transmit/receive completion interrupt (INTCE<sub>n</sub>T)
  - CSIBUF<sub>n</sub> overflow interrupt (INTCE<sub>n</sub>TIOF)
- 3-wire
  - SO<sub>n</sub>: Serial data output
  - SI<sub>n</sub>: Serial data input
  - SCK<sub>n</sub>: Serial clock I/O

**Remark** n = 0, 1

### 18.3 Configuration

The following shows the block diagram of CSIE<sub>n</sub>.

**Figure 18-1. Block Diagram of CSIE<sub>n</sub> (1/2)**

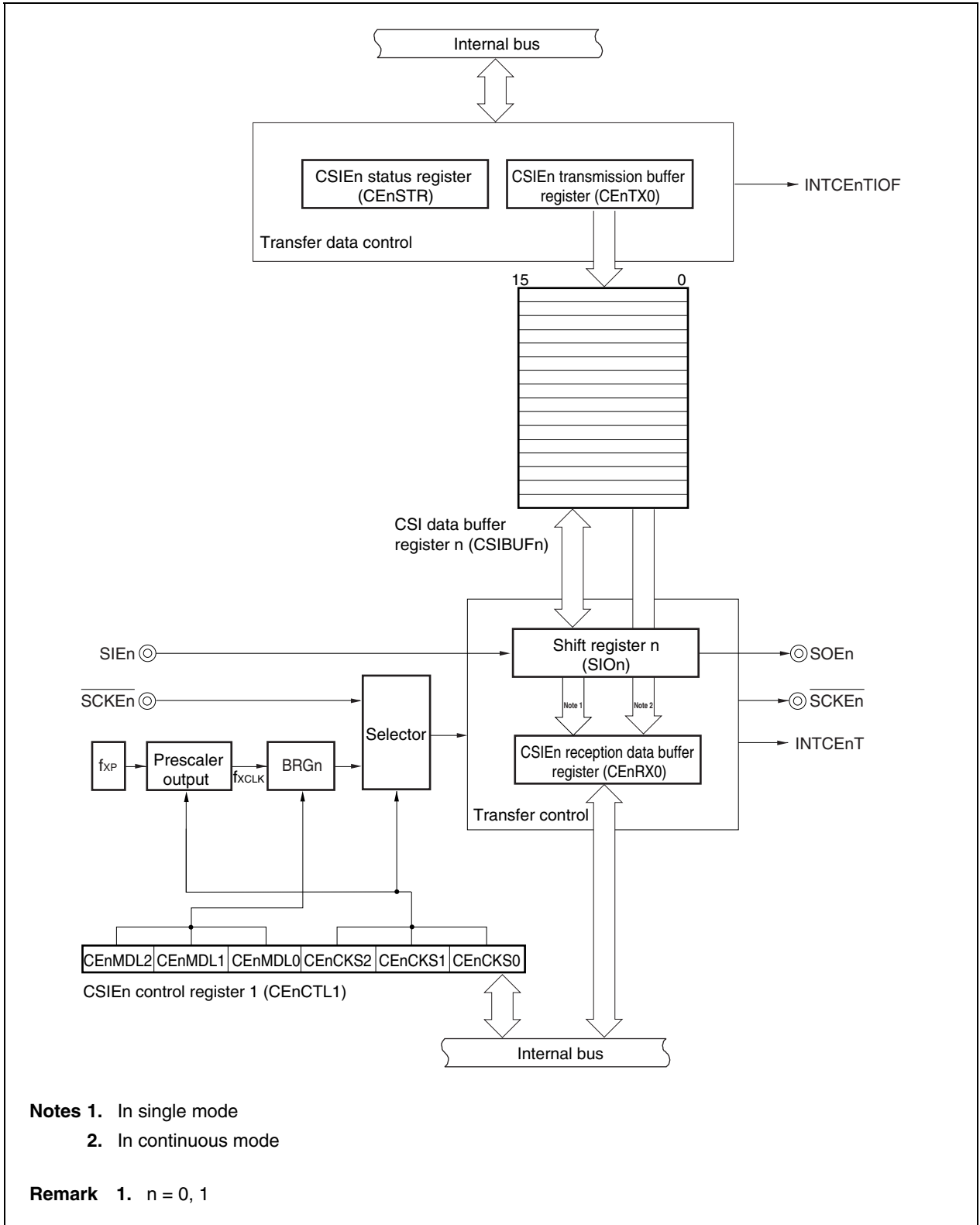

**Figure 18-1. Block Diagram of CSIE<sub>n</sub> (2/2)**

**Remark 2.**  $f_{XP}$ : Peripheral clock frequency (prescaler 1 input clock frequency)  
 In clock mode 1,  $f_{XP} = f_{XX}$   
 In clock mode 2,  $f_{XP} = f_{XMPLL}/2$  (14.64 to 16 MHz)  
 In clock mode 3,  $f_{XP} = f_{XMPLL}$  (29.28 to 32 MHz)  
 In clock mode 4,  $f_{XP} = f_{XMPLL}/2$  (20.88 to 24 MHz)

$f_{XX}$ : Main clock frequency  
 $f_{XMPLL}$ : PLL output clock frequency for peripheral clock  
 $f_{XCLK}$ : Base clock selected in CEnCTL1.CEnCKS2 to CEnCKS0 bit

CSIE<sub>n</sub> includes the following hardware.

**Table 18-4. Configuration of CSIE<sub>n</sub>**

Item	Configuration
Registers	Serial I/O shift register n (SIO <sub>n</sub> ) CSIE <sub>n</sub> receive data buffer register (CEnRX0) CSIE <sub>n</sub> transmit data buffer register (CEnTX0) CSI data buffer register n (CSIBUF <sub>n</sub> )
Control registers	CSIE <sub>n</sub> control register 0 (CEnCTL0) CSIE <sub>n</sub> control register 1 (CEnCTL1) CSIE <sub>n</sub> control register 2 (CEnCTL2) CSIE <sub>n</sub> control register 3 (CEnCTL3) CSIE <sub>n</sub> status register (CEnSTR)

**(1) Serial I/O shift registers n (SIO<sub>n</sub>)**

The SIO<sub>n</sub> register is an 8-bit register for converting between serial data and parallel data. SIO<sub>n</sub> is used for both transmission and reception.

Data is shifted in (reception) or shifted out (transmission) beginning at either the MSB side or the LSB side.

**(2) CSIE<sub>n</sub> receive data buffer register (CEnRX0)**

The CEnRX0 register is a 16-bit buffer register that stores receive data.

By consecutively reading this register in the continuous mode (CEnCTL0.CEnTMS bit = 1), the received data in the CSIBUF<sub>n</sub> register can be sequentially read while the CSIBUF<sub>n</sub> pointer for reading is incremented. However, if the number of the read value exceeds the receive data count in the CEnRX0 register, the read value becomes undefined.

In the single mode (CEnCTL0.CEnTMS bit = 0), received data is read by reading the CEnRX0 register and it is judged that the CEnRX0 register has become empty.

The CEnRX0 register is read-only, in 16-bit units.

When the higher 8 bits of the CEnRX0 register are used as the CEnRX0H register and the lower 8 bits as the CEnRX0L register, these registers are read-only, in 8-bit units. When reading in 8-bit units, be sure to read the CEnRX0H register and CEnRX0L register in that order. The received data is always read from the lower bits, regardless of the transfer direction. If the received data is 8 bits, read the CEnRX0L register only.

Reset sets this register to 0000H. But, be undefined in the consecutive mode.

In addition to reset input, the CEnRX0 register can be initialized by clearing (to 0) the CEnCTL0.CEnPWR bit.

**Caution** Because the values of the CEnFLF, CEnEMF, CEnTSF, CEnSFP3 to CEnSFP0 bits may change at any time during transfer, their values during transfer may differ from the actual values. Especially, use the CEnTSF bit independently (do not use this bit in relation with the other bits). To detect the end of transfer by the CEnSTR register, check to see if the CEnEMF bit is 1 after the data to be transferred has been written to the CSIBUF<sub>n</sub> register.

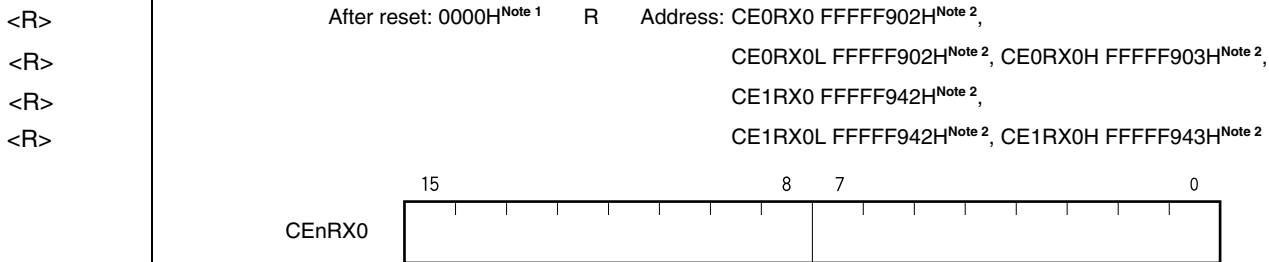

**Notes 1.** In continuous mode (CEnCTL0.CEnTMS = 1): Undefined

**2.** Other than the  $\mu$ PD70F3931 (V850E/SJ3-H), 70F3932 (V850E/SJ3-H), and 70F3933 (V850E/SJ3-H)

The following shows the CEnRX0 register in reading by each transfer mode.

Transfer Mode	CEnRX0
Single mode (CEnCTL0.CEnTMS bit = 0)	Reading the data value in reception data buffer
Consecutive mode (CEnCTL0.CEnTMS bit = 1)	Reading the reception data value in the CSIBUF <sub>n</sub> pointer for current read showing (the initial value of the CSIBUF <sub>n</sub> register by reset is undefined).

**(3) CSIE transmit data buffer register (CEnTX0)**

The CEnTX0 register is a 16-bit buffer register that stores transmit data. When transmit data is written to this register, the data is sequentially stored in the CSIBUFn register while the CSIBUFn pointer for writing is incremented. Writing to the CEnTX register for the number of times exceeding the set value of the CEnCTL3.CEnSFN3 to CEnCTL3.CEnSFN0 bits (CSIE transfer data count) during the continuous transfer mode (CEnCTL0.CEnTMS bit = 1) is prohibited. When the data of this register is read, the value of the transmit data written last is read. The CEnTX0 register can be read or written in 16-bit units. When the higher 8 bits of the CEnTX0 register are used as the CEnTX0H register, and the lower 8 bits as the CEnTX0L register, these registers can be read or written in 8-bit units. When reading in 8-bit units, be sure to read the CEnTX0H register and CEnTX0L register in that order. In addition, write the transmission data from the lower bits, regardless of the transfer direction. If the transmission data is 8 bits, write the CEnTX0L register only. Reset sets this register to 0000H.

**Caution** Accessing the CEnTX0 register is prohibited in the following statuses. For details, refer to 3.4.9 (2) Accessing specific on-chip peripheral I/O registers.

- When the CPU operates with the subclock and the main clock oscillation is stopped
- When the CPU operates with the internal oscillation clock

<R> After reset: 0000H R/W Address: CE0TX0 FFFFF906H<sup>Note</sup>,  
 <R> CE0TX0L FFFFF906H<sup>Note</sup>, CE0TX0H FFFFF907H<sup>Note</sup>,  
 <R> CE1TX0 FFFFF946H<sup>Note</sup>,  
 <R> CE1TX0L FFFFF946H<sup>Note</sup>, CE1TX0H FFFFF947H<sup>Note</sup>

<R> **Note** Other than the  $\mu$ PD70F3931 (V850E/SJ3-H), 70F3932 (V850E/SJ3-H), and 70F3933 (V850E/SJ3-H)

The following shows the CEnTX0 register operation in reading/writing.

Read/Write	Operation of CEnTX0 Register
Write	Storing the transmission data in the CSIBUFn register by step
Read	Reading the value of transmission data writing at last

**(4) CSI data buffer register n (CSIBUFn)**

By consecutively writing transmit data to the CEnTX0 register from where it is transferred, up to sixteen 16-bit data can be stored in the CSIBUFn register while the CSIBUFn pointer for writing is automatically incremented. In the continuous mode, the data received in the CSIBUFn register can be sequentially read while the read CSIBUFn pointer is automatically incremented, by continuously reading the receive data from the CEnRX0 register.

## 18.4 Control Registers

The following registers are used to control CSIE.

- CSIE control register 0 (CEnCTL0)
- CSIE control register 1 (CEnCTL1)
- CSIE control register 2 (CEnCTL2)
- CSIE control register 3 (CEnCTL3)
- CSIE status register (CEnSTR)

**(1) CSIE<sub>n</sub> control register 0 (CEnCTL0)**

The CEnCTL0 register controls the operation of CSIE<sub>n</sub>.

These registers can be read or written in 8-bit or 1-bit units. Writing the CEnTMS, CEnDIR, and CEnSIT bits is enabled only when CEnTXE bit = 0 and CEnRXE bit = 0.

Reset sets this register to 00H.

**Caution** Accessing the CEnCTL0 register is prohibited in the following statuses. For details, refer to 3.4.9 (2) Accessing specific on-chip peripheral I/O registers.

- When the CPU operates with the subclock and the main clock oscillation is stopped
- When the CPU operates with the internal oscillation clock

(1/2)

<R>

After reset: 00H R/W Address: CE0CTL0 FFFF900H<sup>Note</sup>, CE1CTL0 FFFF940H<sup>Note</sup>

	<7>	<6>	<5>	<4>	<3>	2	1	0
CEnCTL0	CEnPWR	CEnTXE	CEnRXE	CEnTMS	CEnSIT	CEnSIT	0	0

(n = 0, 1)

CEnPWR	Disables CSIE <sub>n</sub> operation/Specifies inhibited
0	CSIE <sub>n</sub> operation disables
1	CSIE <sub>n</sub> operation enables
<ul style="list-style-type: none"> <li>• The CSIE<sub>n</sub> unit is reset when the CEnPWR bit = 0, and CSIE<sub>n</sub> is stopped. To operate CSIE<sub>n</sub>, first set the CEnPWR bit to 1.</li> <li>• When rewriting the CEnPWR bit from 0 to 1 or from 1 to 0, simultaneously rewriting the bits other than the CEnCTL0.CEnPWR register is prohibited. When the CEnPWR bit = 0, rewriting the bits other than the CEnPWR bit of the CEnCTL0 register, and the CEnTX0, CEnTX0L, and CEnSTR registers is prohibited.</li> </ul>	

CEnTXE	Enables or disables transmission
0	Disables transmission operation.
1	Enables transmission operation.
<ul style="list-style-type: none"> <li>• The CEnTXE bit is reset when the CEnPWR bit is cleared to 0.</li> <li>• When the CEnPWR bit = 1, after the CEnTXE bit has been cleared to 0, setting the CEnTXE bit to 1 before 2 cycles of the operation clock (f<sub>OP</sub>) elapse is disabled. The transmit operation is enabled after the CEnTXE bit has been set to 1, and 2 cycles of the operation clock (f<sub>OP</sub>) have elapsed.</li> </ul>	

<R>

**Note** Other than the μPD70F3931 (V850E/SJ3-H), 70F3932 (V850E/SJ3-H), and 70F3933 (V850E/SJ3-H)

**Caution** Be sure to clear bits 0 and 1 to “0”. If these bits are set to 1, the operation is not guaranteed.



CEnRXE	Enables or disables reception
0	Disables reception.
1	Enables reception.

- The CEnRXE bit is reset when the CEnPWR bit is cleared to 0.
- When the CEnPWR bit = 1, after the CEnRXE bit has been cleared to 0, setting the CEnRXE bit to 1 before 2 cycles of the operation clock ( $f_{XP}$ ) elapse is disabled. The receive operation is enabled after the CEnRXE bit has been set to 1 and 2 cycles of the operation clock ( $f_{XP}$ ) have elapsed.

CEnTMS	Specifies the transfer mode
0	Single mode
1	Continuous mode

CEnDIR	Specifies the transfer direction (MSB/LSB)
0	MSB first
1	LSB first

- Specifies the transfer direction when data is written from the CEnTX0 register to the CSIBUFn register or read from the CEnRX0 and CSIBUFn registers.

CEnSIT	Controls delay of the transmission completion interrupt signal (INTCEnT)
0	No delay
1	Delay mode (In the continuous mode (TRMDn = 1), the next data transfer is delayed half a cycle because a delay of half a cycle is inserted when transfer of 1-bit data is complete.)

- The delay mode (CEnSIT bit = 1) is valid only in the master mode (when the CEnCKS2 to CEnCKS0 bits are other than 111). In the slave mode (when the CEnCKS2 to CEnCKS0 bits are 111), do not set the delay mode. Even if the delay mode is set, INTCEnT is not affected by the CEnSIT bit.
- If the CEnSIT bit is set to 1 in the continuous mode (TRMDn bit = 1), the INTCEnT interrupt is not output except when the last data set by the CEnCTL3.CEnSFN3 to CEnCTL3.CEnSFN0 bits is transferred, but a delay of half a clock ( $1/2$  serial clock) can be inserted between each data transfer.

(2) CSIE control register 1 (CEnCTL1)

The CEnCTL1 register is an 8-bit register that controls the operation clock and operating mode of CSIE. These registers can be read or written in 8-bit or 1-bit units. Data can be written to the CEnCTL1 register only when the CEnCTL0.CEnTXE bit = 0 and CEnRXE bit = 0. Reset sets this register to 07H.

(1/2)

<R>

After reset 07H R/W Address: CE0CTL1 FFFFFFF901H<sup>Note</sup>, CE1CTL1 FFFFFFF941H<sup>Note</sup>.

	7	6	5	4	3	2	1	0
CEnCTL1	CEnMDL2	CEnMDL1	CEnMDL0	CEnCKP	CEnDAP	CEnCKS2	CEnCKS1	CEnCKS0
(n = 0, 1)								

CEnMDL2	CEnMDL1	CEnMDL0	Set Value (N)	Specification the transfer clock (BRGn output signal)
0	0	0	–	BRGn stop mode (power save)
0	0	1	1	$f_{XCLK}/2$
0	1	0	2	$f_{XCLK}/4$
0	1	1	3	$f_{XCLK}/6$
1	0	0	4	$f_{XCLK}/8$
1	0	1	5	$f_{XCLK}/10$
1	1	0	6	$f_{XCLK}/12$
1	1	1	7	$f_{XCLK}/14$

• In the slave mode (CEnCKS2 to CEnCKS0 bits = 111), clear the CEnMDL2 to CEnMDL0 bits to 000 (BRGn stop mode).

	CEnCKP	CEnDAP	Specification the data transmission/reception timing for SCKEn
Communication type 1	0	0	
Communication type 2	0	1	
Communication type 3	1	0	
Communication type 4	1	1	

<R>

**Note** Other than the  $\mu$ PD70F3931 (V850E/SJ3-H), 70F3932 (V850E/SJ3-H), and 70F3933 (V850E/SJ3-H)

**Remark**  $f_{XCLK}$ : Base clock selected by CEnCKS2 to CEnCKS0 bit

CEnCKS2	CEnCKS1	CEnCKS0	Set Value (N)	Base clock ( $f_{CLK}$ )	Mode
0	0	0	0	$f_{XP}$	Master mode
0	0	1	1	$f_{XP}/2$	Master mode
0	1	0	2	$f_{XP}/4$	Master mode
0	1	1	3	$f_{XP}/8$	Master mode
1	0	0	4	$f_{XP}/16$	Master mode
1	0	1	5	$f_{XP}/32$	Master mode
1	1	0	6	$f_{XP}/64$	Master mode
1	1	1	–	External clock (SCKEn)	Slave mode

- If the CEnCKS2 to CEnCKS0 bits are cleared to 000, setting the CEnMDL2 to CEnMDL0 bit to 001 is prohibited.

**Remark**  $f_{XP}$ : Peripheral clock frequency (prescaler 1 input clock frequency)  
 In clock mode 1,  $f_{XP} = f_{XX}$   
 In clock mode 2,  $f_{XP} = f_{XMPLL}/2$  (14.64 to 16 MHz)  
 In clock mode 3,  $f_{XP} = f_{XMPLL}$  (29.28 to 32 MHz)  
 In clock mode 4,  $f_{XP} = f_{XMPLL}/2$  (20.88 to 24 MHz)  
 $f_{XX}$ : Main clock frequency  
 $f_{XMPLL}$ : PLL output clock frequency for peripheral clock

**(3) CSIE<sub>n</sub> control register 2 (CEnCTL2)**

The CEnCTL2 register is used to select the transfer data length of CSIE<sub>n</sub>.

These registers can be read or written in 8-bit or 1-bit units.

The CEnCTL2 register may be transferring data when the CEnCTL0.CEnTXE bit or CEnRXE bit is 1. Be sure to clear the CEnTXE and CEnRXE bits to 0 before writing data to the CEnCTL2 register.

Reset sets this register to 00H.

<R>

After reset: 00H    R/W    Address: CE0CTL2 FFFF909H<sup>Note</sup>, CE1CTL2 FFFF949H<sup>Note</sup>

	7	6	5	4	3	2	1	0
CEnCTL2	0	0	0	0	CEnDLS3	CEnDLS2	CEnDLS1	CEnDLS0

(n = 0, 1)

CEnDLS3	CEnDLS2	CEnDLS1	CEnDLS0	Specification of transfer bit length
0	0	0	0	16 bits
1	0	0	0	8 bits
1	0	0	1	9 bits
1	0	1	0	10 bits
1	0	1	1	11 bits
1	1	0	0	12 bits
1	1	0	1	13 bits
1	1	1	0	14 bits
1	1	1	1	15 bits
Other than above				Setting prohibited
<ul style="list-style-type: none"> <li>• If a transfer data length other than 16 bits is specified (CEnDLS3 to CEnDLS0 bits = 0000), an undefined value is read to the higher excess bits of the CEnRX0 and CSIBUF<sub>n</sub> registers (see <b>18.6 (3) Data transfer direction specification function</b>).</li> </ul>				

<R>

**Note** Other than the  $\mu$ PD70F3931 (V850E/SJ3-H), 70F3932 (V850E/SJ3-H), and 70F3933 (V850E/SJ3-H)

**Caution** Be sure to clear bits 7 to 4 to “0”. If they are set to 1, the operation is not guaranteed.

**(4) CSIE<sub>n</sub> status register (CEnCTL3)**

The CEnCTL3 register is used to set the number of transfer data of CSIE<sub>n</sub> in the continuous mode (CEnCTL0.CEnTMS bit = 1). Rewriting of the CEnCTL3 register is prohibited during transfer in the continuous mode (CEnSTR.CEnTSF bit = 1).

These registers can be read or written in 8-bit or 1-bit units.

Reset sets this register to 00H.

<R>

After reset: 00H R/W Address: CE0CTL3 FFFFF90CH<sup>Note</sup>, CE1CTL3 FFFFF94CH<sup>Note</sup>

	7	6	5	4	3	2	1	0
CEnCTL3	0	0	0	0	CEnSFN3	CEnSFN2	CEnSFN1	CEnSFN0

(n = 0, 1)

CEnSFN3	CEnSFN2	CEnSFN1	CEnSFN0	Specification of number of transfer data
0	0	0	0	16
0	0	0	1	1
0	0	1	0	2
0	0	1	1	3
0	1	0	0	4
0	1	0	1	5
0	1	1	0	6
0	1	1	1	7
1	0	0	0	8
1	0	0	1	9
1	0	1	0	10
1	0	1	1	11
1	1	0	0	12
1	1	0	1	13
1	1	1	0	14
1	1	1	1	15

- Writing data exceeding the value set by the CEnSFN3 to CEnSFN0 bits (number of CSIE<sub>n</sub> transfer data) to the CSIBUF<sub>n</sub> register is prohibited.

<R>

**Note** Other than the  $\mu$ PD70F3931 (V850E/SJ3-H), 70F3932 (V850E/SJ3-H), and 70F3933 (V850E/SJ3-H)

**Caution** Be sure to clear bits 7 to 4 to "0".

**(5) CSIEn status register (CEnSTR)**

These registers indicate the status of the CSIBUFn register or the transfer status.

These registers can be read or written in 8-bit or 1-bit units (however, bits 6 to 0 can only be read. They do not change even if they are written).

Reset sets this register to 20H.

In addition to reset input, the CEnSTR register can be initialized by clearing (0) the CEnCTL0.CEnPWR bit.

**Cautions 1. Accessing the CEnSTR register is prohibited in the following statuses. For details, refer to 3.4.9 (2) Accessing specific on-chip peripheral I/O registers.**

- When the CPU operates with the subclock and the main clock oscillation is stopped
  - When the CPU operates with the internal oscillation clock
- 2. Because the values of the CEnFLF, CEnEMF, CEnTSF, CEnSFP3 to CEnSFP0 bits may change at any time during transfer, their values during transfer may differ from the actual values. Especially, use the CEnTSF bit independently (do not use this bit in relation with the other bits). To detect the end of transfer by the CEnSTR register, check to see if the CEnEMF bit is 1 after the data to be transferred has been written to the CSIBUFn register.**

<R>

After reset: 20H R/W Address: CE0STR FFFF908H<sup>Note</sup>, CE1STR FFFF948H<sup>Note</sup>

	<7>	<6>	<5>	<4>	3	2	1	0
CEnSTR (n = 0, 1)	CEnPCT	CEnFLF	CEnEMF	CEnTSF	CEnSFP3	CEnSFP2	CEnSFP1	CEnSFP0

CEnPCT	Specifies clearing of the CSIBUFn pointer
0	No operation
1	Clear all CSIBUFn pointers to 0.
<ul style="list-style-type: none"> <li>This bit is always 0 when it is read.</li> <li>If 1 is written to the CEnPCT bit in the middle of transfer, transfer is aborted. Because all the CSIBUFn pointers are cleared to 0, the remaining data in the CSIBUFn register is ignored. If 1 is written to the CEnPCT bit, be sure to read the CEnSTR register to check to see if all the CSIBUFn pointers have been correctly cleared to 0 (CEnFLF bit = 0, CEnEMF bit = 1, CEnSFP3 to CEnSFP0 bits = 0000). Writing to the CEnPCT bit is prohibited before confirming that all CSIBUFn pointers have been cleared to 0 without fail.</li> </ul>	

CEnFLF	This flag indicates the full status of the CSIBUFn register
0	CSIBUFn register has a vacancy.
1	CSIBUFn register is full.
<ul style="list-style-type: none"> <li>This bit is cleared to 0 when the CEnCTL0.CEnPWR register is cleared to 0 or when the CEnPCT bit is set to 1.</li> <li>If transfer of 16 data is specified in the continuous mode (CEnCTL0.CEnTMS bit = 1) (CEnCTL0.CEnTMS bit = 0000), the CEnFLF bit is set to 1 in the same way as in the single mode (CEnCTL0.CEnTMS bit = 1) when 16 data are in the CSIBUFn register. If even one of the data has been completely transferred, the CEnFLF bit is cleared to 0. However, this does not mean that the CSIBUFn register has a vacancy. In this case, writing the next transmission data to the CSIBUFn register is prohibited. Even if the data is written to the CSIBUFn register, it is not transferred. If a data reception process is executed, the received data is overwritten. To execute the next transfer, be sure to wait until all transfers have completed, then write 1 to the CEnPCT bit to clear (0) the all CSIBUFn pointers.</li> </ul>	

CEnEMF	This flag indicates the empty status of the CSIBUFn register
0	Data is in CSIBUFn register.
1	CSIBUFn register is empty.
<ul style="list-style-type: none"> <li>This flag is set to 1 when the CEnCTL0.CEnPWR register is cleared to 0 or when the CEnPCT bit is set to 1.</li> <li>If the data written to the CSIBUFn register has been transferred, the CEnEMF bit is set to 1 (even if receive data is stored in the CSIBUFn register).</li> </ul>	

**Note** Other than the  $\mu$ PD70F3931 (V850E/SJ3-H), 70F3932 (V850E/SJ3-H), and 70F3933 (V850E/SJ3-H)

<R>

CEnTSF	This flag indicates transfer status
0	Idle status
1	Transfer or transfer start processing in progress

- This flag is cleared to 0 when the CEnCTL0.CEnPWR register is cleared to 0 and the CEnPCT bit is set to 1, or when the CEnCTL0.CEnTXE bit = 0 and CEnCTL0.CEnRXE bit = 0 register are cleared to 0.
- This flag is “1” from when transfer is started until there is no more transfer data in the CSIBUFn register in the single mode (CEnCTL0.CEnTMS bit = 0) or until the specified number of data has been transferred in the continuous mode (CEnCTL0.CEnTMS bit = 1).

CEnSFP3 to CEnSFP0	<ul style="list-style-type: none"> <li>• In the single mode (CEnCTL0.CEnTMS bit = 0), the “number of transfer data remaining in CSIBUFn register (CSIBUFn pointer value for writing – CSIBUFn pointer value for SIOn loading)” can be read.</li> <li>• In the continuous mode (CEnCTL0.CEnTMS bit = 1), the “number of data completely transferred (value of CSIBUFn pointer for SIOn loading/storing)” can be read. If the CEnSFP3 to CEnSFP0 bits are 0H, however, the number of transferred data is as follows, depending on the setting of the CEnEMF bit. <ul style="list-style-type: none"> <li>When CEnEMF bit = 0: Number of transferred data = 0</li> <li>When CEnEMF bit = 1: Number of transferred data = 16 or status before starting transfer (before writing transfer data)</li> </ul> </li> </ul>
	<ul style="list-style-type: none"> <li>• These bits are cleared to 0 in synchronization with the operating clock when the CEnPCT bit = 1. However, the values of these bits are held until the CEnCTL0.CEnPWR register is cleared to 0 or the CEnPCT bit is set to 1.</li> </ul>



## 18.5 Baud Rate Generator n (BRGn)

The transfer clock of CSIE<sub>n</sub> can be selected from the output of a dedicated baud rate generator or external clock ( $n = 0, 1$ ).

The serial clock source is specified by the CEnCTL1 register.

In the master mode (CEnCTL1.CEnCKS2 to CEnCTL1.CEnCKS0 bits = other than 111 in the CSIE<sub>n</sub> register), BRG<sub>n</sub> is selected as the clock source.

### (1) Transfer clock

Figure 18-2. Transfer Clock of CSIE<sub>n</sub>

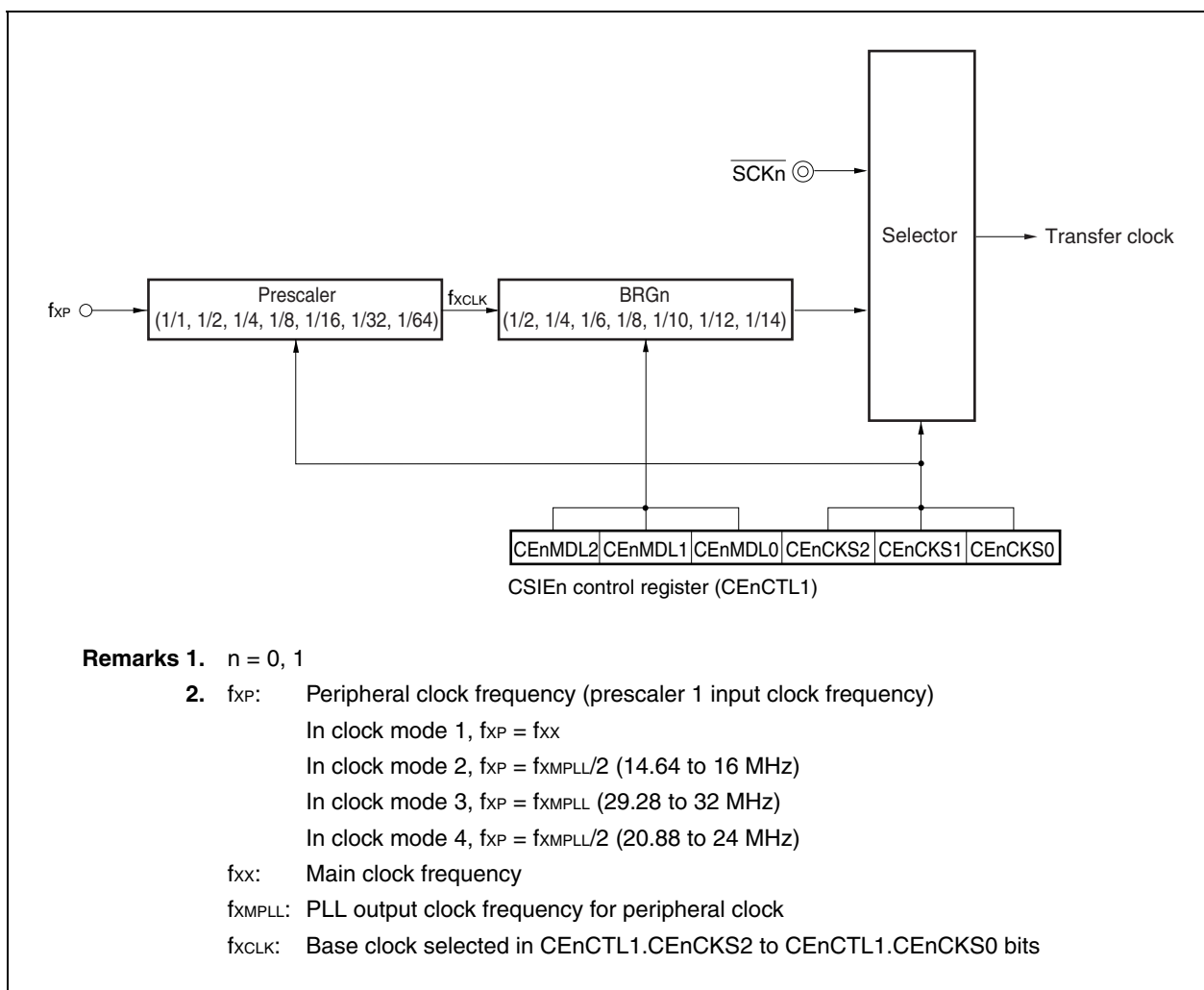

**(2) Baud rate**

The baud rate is calculated by the following expression.

$$\text{Baud rate} = \frac{F}{N \times 2^{k+1}} \text{ [bps]}$$

$F = f_{XP}$

$K =$  Value set by CEnCTL1.CEnCKS2 to CEnCTL1.CEnCKS0 bits ( $K = 0, 1, 2, \dots, 6$ )

$N =$  Value set by CEnCTL1.CEnMDL2 to CEnCTL1.CEnMDL0 bits ( $N = 1, 2, 3, \dots, 7$ )

**Caution** If the CEnCTL1.CEnCKS2 to CEnCTL1.CEnCKS0 bits are cleared to 000, setting the CEnCTL1.CEnMDL2 to CEnCTL1.CEnMDL0 bits to 001 is prohibited.

**Remark**  $f_{XP}$ : Peripheral clock frequency (prescaler 1 input clock frequency)

In clock mode 1,  $f_{XP} = f_{XX}$

In clock mode 2,  $f_{XP} = f_{XMPLL}/2$  (14.64 to 16 MHz)

In clock mode 3,  $f_{XP} = f_{XMPLL}$  (29.28 to 32 MHz)

In clock mode 4,  $f_{XP} = f_{XMPLL}/2$  (20.88 to 24 MHz)

$f_{XX}$ : Main clock frequency

$f_{XMPLL}$ : PLL output clock frequency for peripheral clock

**(3) Example of baud rate setting (unit: Mbps)**

**Table 18-5. Baud Rate Generator Setting Data in  $f_{XP} = 32$  MHz**

K \ N	1	2	3	4	5	6	7
0	Setting prohibited	8	5.3333	4	3.2	2.6667	2.2857
1	8	4	2.6667	2	1.6	1.3333	1.1429
2	4	2	1.3333	1	0.8	0.6667	0.5714
3	2	1	0.6667	0.5	0.4	0.3333	0.2857
4	1	0.5	0.3333	0.25	0.2	0.1667	0.1429
5	0.5	0.25	0.1667	0.125	0.1	0.0833	0.0714
6	0.25	0.125	0.0833	0.0625	0.05	0.0417	0.0357

## 18.6 Operation

### (1) Operation modes

**Table 18-6. Operation Modes**

CEnTMS Bit	CEnCKS2 to CEnCKS0 Bits	CEnTXE, CEnRXE Bits	CEnDIR Bit	CEnSIT bit
Single mode	Master mode	Transmission, reception, transmission/reception	MSB/LSB first	Enables/disables INTCEnT delay mode
	Slave mode			–
Consecutive mode	Master mode			Enables/disables INTCEnT delay mode
	Slave mode			–

- Remarks**
- CEnTXE bit: Bit 6 of CEnCTL0 register

CEnRXE bit: Bit 5 of CEnCTL0 register

CEnTMS bit: Bit 4 of CEnCTL0 register

CEnDIR bit: Bit 3 of CEnCTL0 register

CEnSIT bit: Bit 2 of CEnCTL0 register

CEnCKS2 to CEnCKS0 bits: Bits 2 to 0 of CEnCTL0 register
  - n = 0, 1

**(2) Function of CSI data buffer registers 0, 1 (CSIBUF0, CSIBUF1)**

By consecutively writing the transmit data to the CEnTX0 register from where it is transferred, up to sixteen 16-bit data can be stored in the CSIBUFn register while the CSIBUFn pointer for writing is automatically incremented (n = 0, 1).

The condition under which transfer is to be started (CEnSTR.CEnEMF bit = 0) is satisfied when data is written to the lower 8 bits (CEnTX0L register) of the CEnTX0 register. If a transfer data length of 9 bits or more is specified (CEnCTL2.CEnDLS3 to CEnCTL2.CEnDLS0 bits = 0000 or 1001 to 1111), data must be written to the CEnTX0 register in 16-bit units or to the CEnTX0H and CEnTX0L registers, in that order, in 8-bit units. If the transfer data length is set to 8 bits (CEnCTL2.CEnDLS3 to CEnCTL2.CEnDLS0 bits = 1000), data must be written to the CEnTX0L register in 8-bit units or to the CEnTX0 register in 16-bit units. (If data is written to the CEnTX0L register in 16-bit units, however, the higher 8 bits of the data (of the CEnTX0H register) are ignored and not transferred).

The CEnSTR.CEnFLF register is set to 1 when 16 data exist in the CSIBUFn register and outputs a CSIBUFn overflow interrupt (INTCEnTIOF) when the CEnFLF bit = 1 and when the 17th transfer data is written (17th transfer data is not written and ignored).

Sixteen data exist in the CSIBUFn register in the single mode (CEnCTL0.CEnTMS bit = 1) when “CSIBUFn pointer value for writing = CSIBUFn pointer value for SIOn loading, and CEnSTR.CEnFLF bit = 1”. When the CSIBUFn pointer for SIOn loading is incremented after completion of transfer while CEnFLF bit = 1, the CEnFLF bit is cleared to 0 and the next transmission data can be written.

In the continuous mode (CEnCTL0.CEnTMS bit = 1), when one data has been transferred, the CEnFLF bit is cleared to 0, but writing the next transmission data is prohibited (if a receive operation is processed, the received data is stored in the CSIBUFn register. Therefore, if the transmission data is written to the register, the received data is overwritten and destroyed).

Figure 18-3. Function of CSI Data Buffer Register n (CSIBUFn)

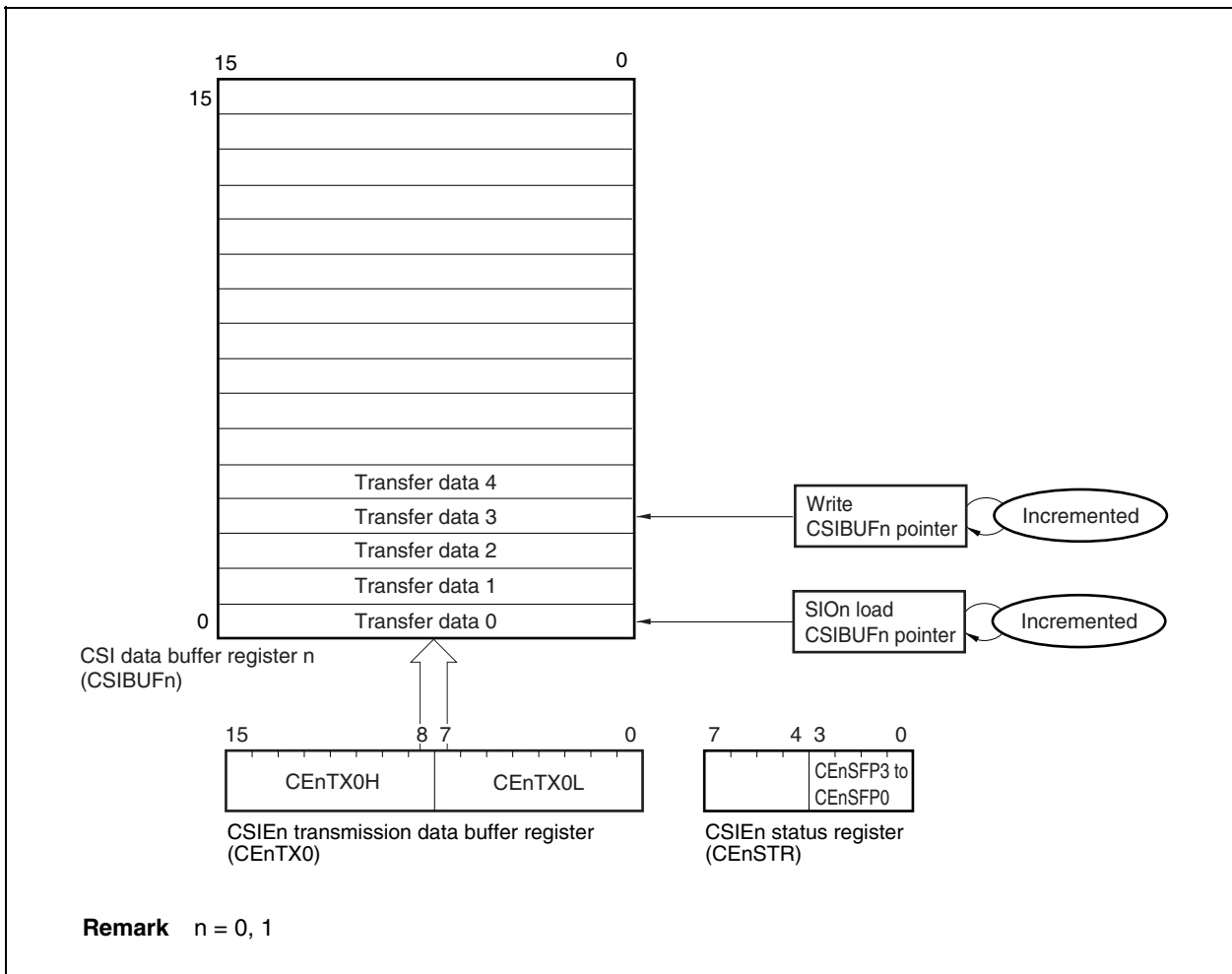

**(3) Data transfer direction specification function**

The data transfer direction can be changed by using the CEnCTL0.CEnDIR bit (n = 0, 1).

**(a) MSB first (CEnDIR bit = 0)**

**Figure 18-4. Transfer Data Length: 8 Bits (CEnCTL2.CEnDLS3 to CEnCTL2.CEnDLS0 bits = 1000), Transfer Direction: MSB First (CEnCTL0.CEnDIR bit = 0) (1/2)**

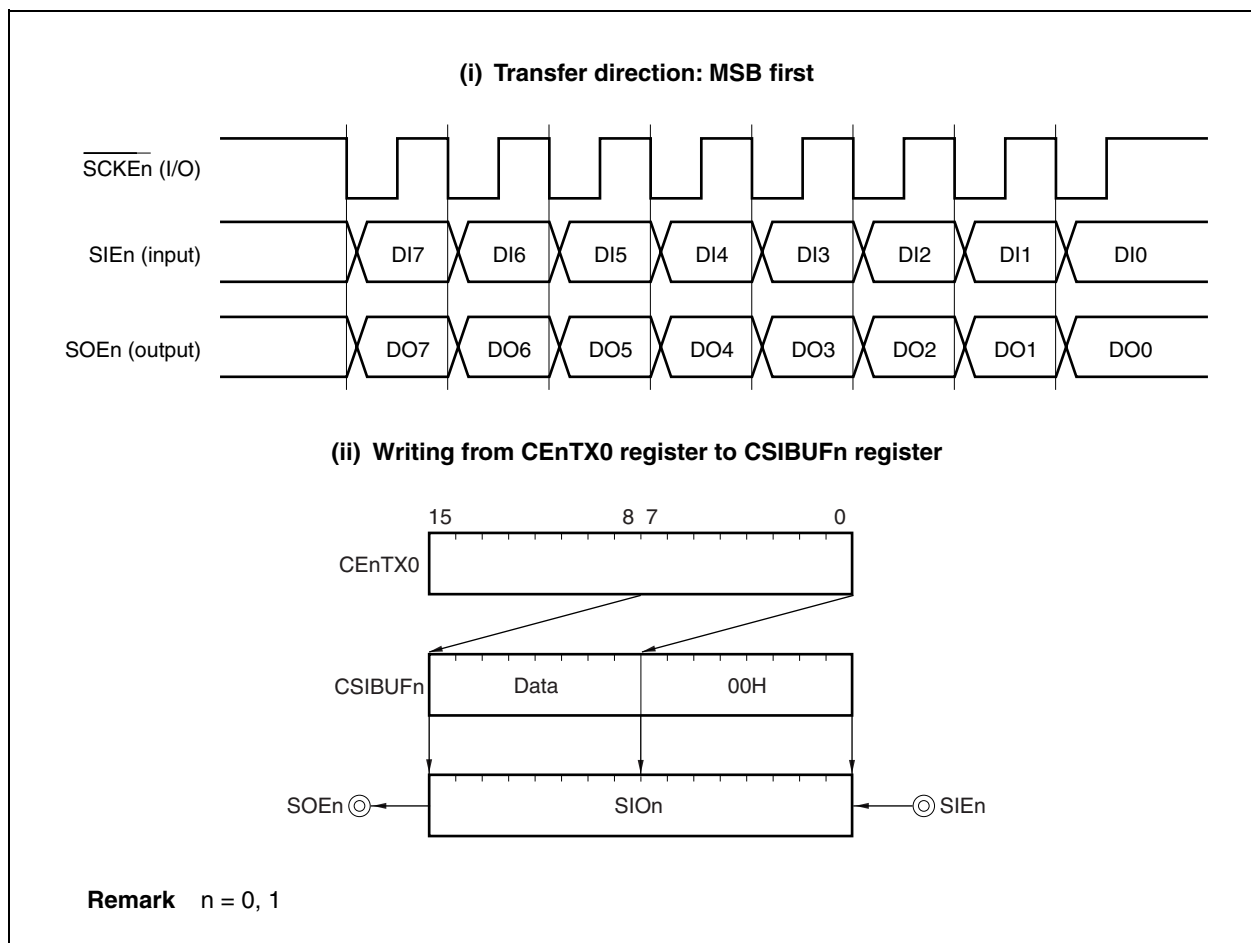

**Figure 18-4. Transfer Data Length: 8 Bits (CEnCTL2.CEnDLS3 to CEnCTL2.CEnDLS0 bits = 1000), Transfer Direction: MSB First (CEnCTL0.CEnDIR bit = 0) (2/2)**

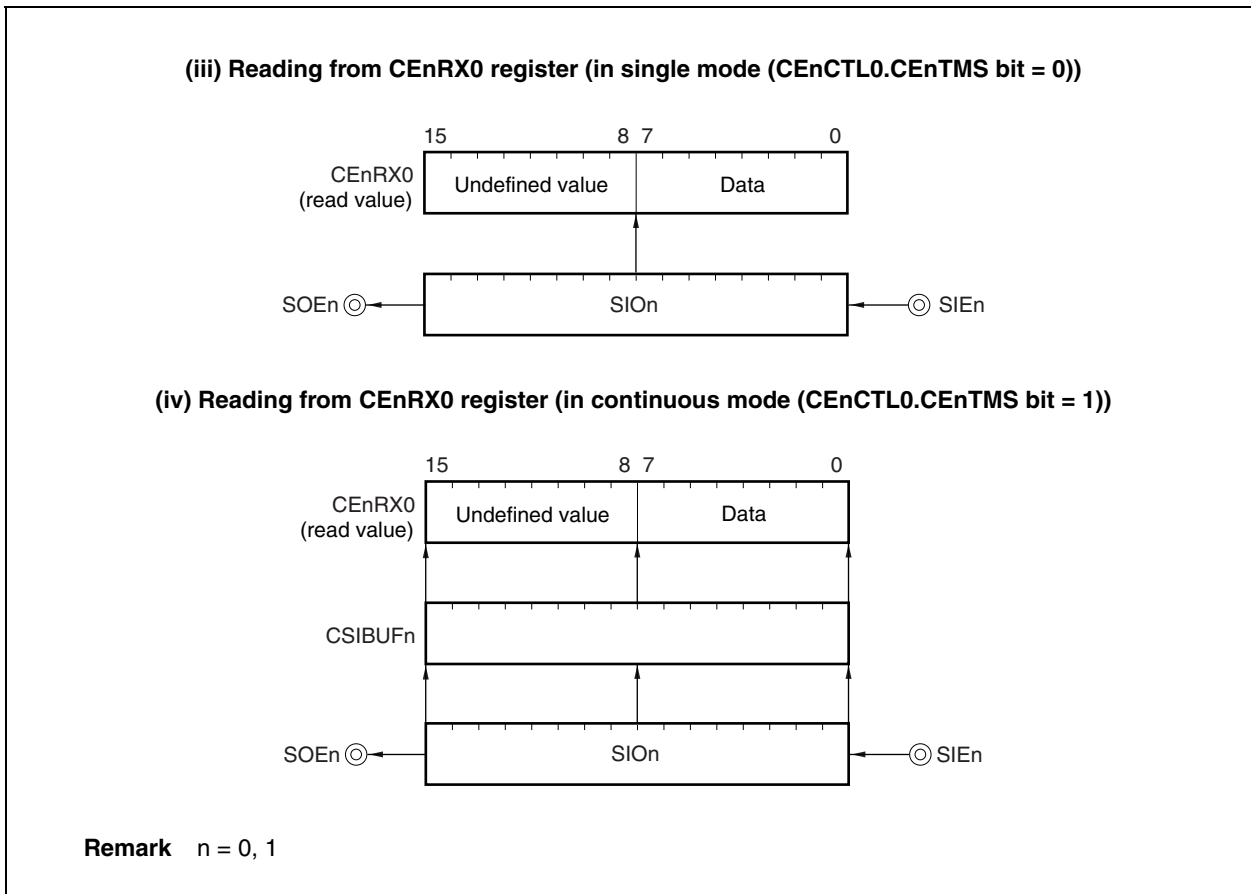

(b) LSB first (CEnDIR bit = 1)

Figure 18-5. Transfer Data Length: 8 Bits (CEnCTL2.CEnDLS3 to CEnCTL2.CEnDLS0 bits = 1000),  
Transfer Direction: LSB First (CEnCTL0.CEnDIR bit = 1) (1/2)

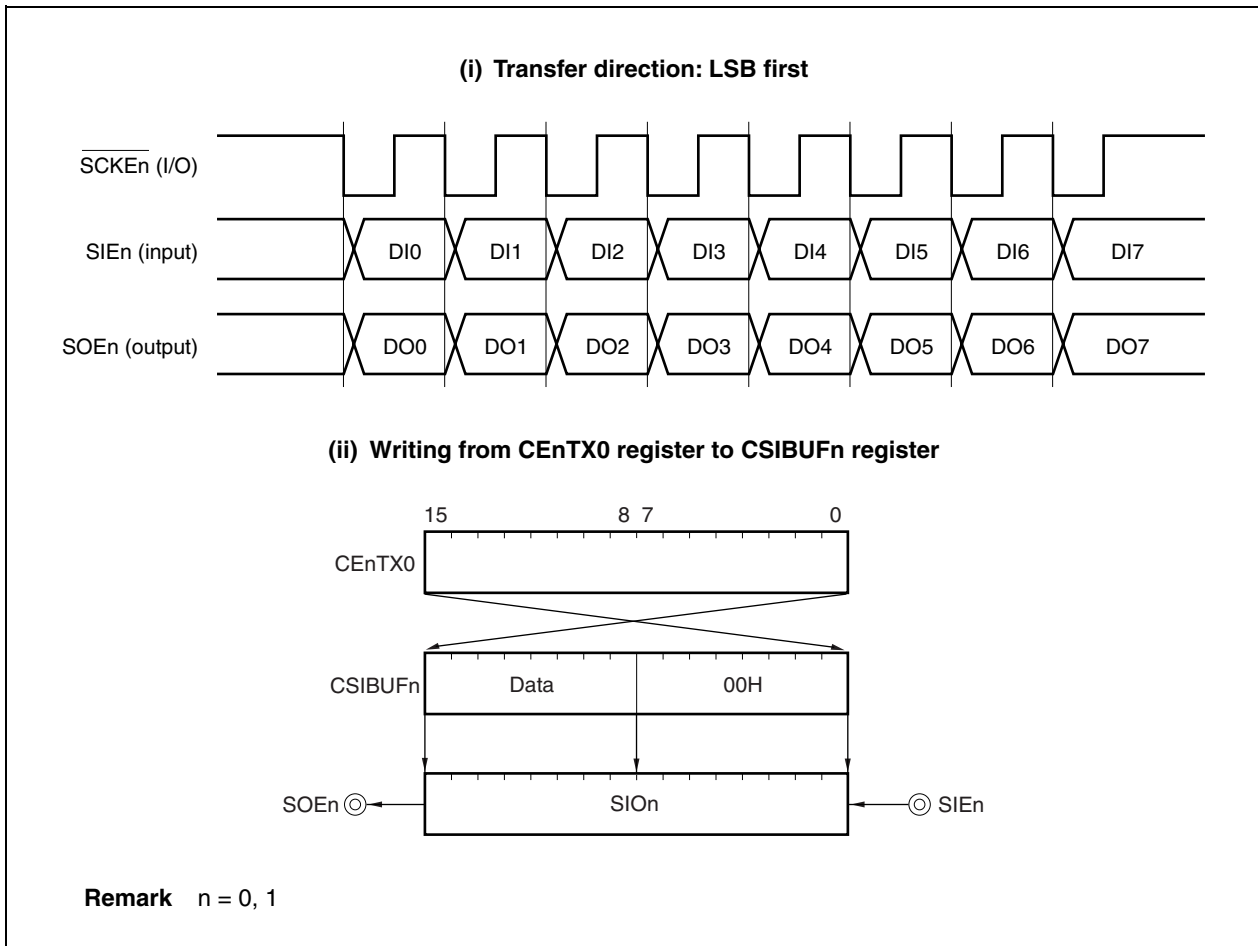
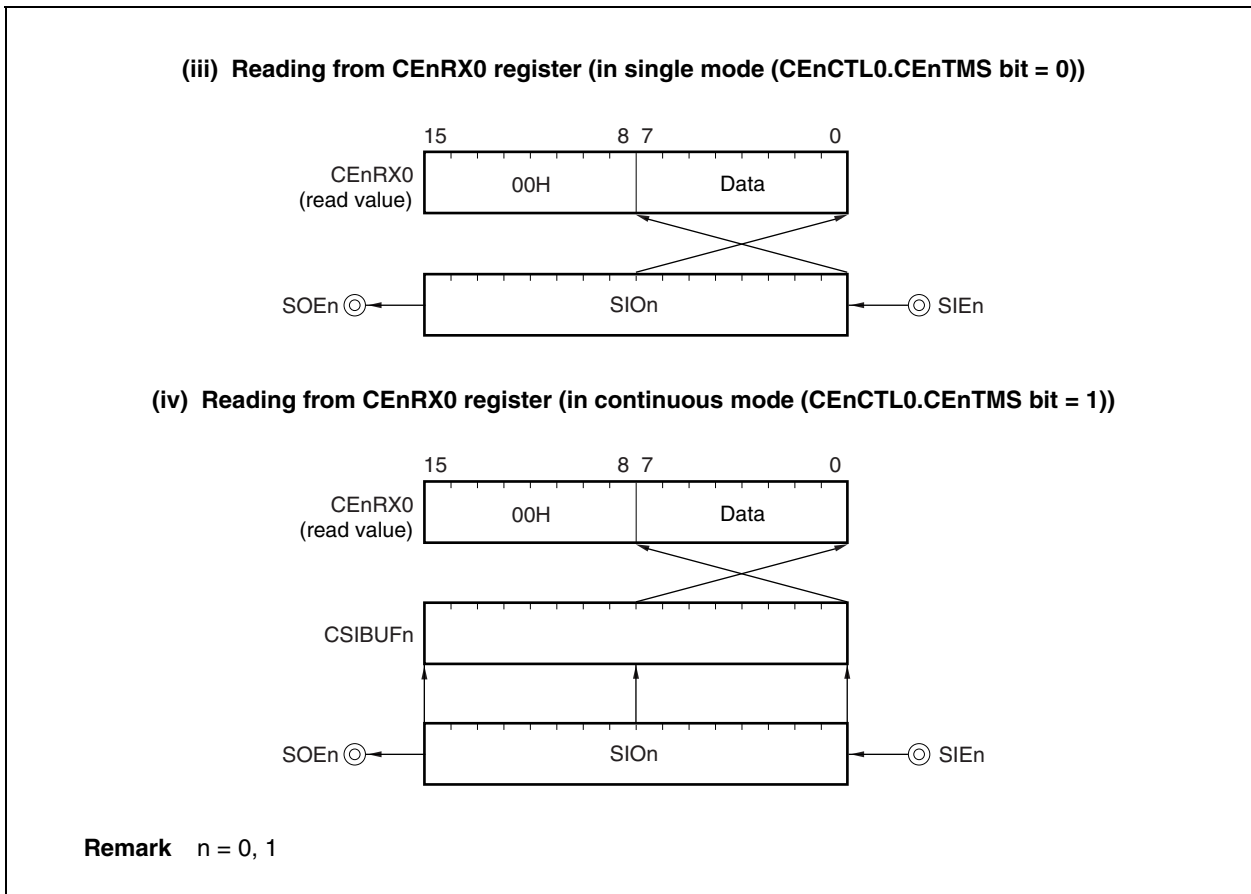



Figure 18-5. Transfer Data Length: 8 Bits (CEnCTL2.CEnDLS3 to CEnCTL2.CEnDLS0 bits = 1000), Transfer Direction: LSB First (CEnCTL0.CEnDIR bit = 1) (2/2)



**(4) Transfer data length changing function**

The transfer data length can be set from 8 to 16 bits in 1-bit units, by using the CEnCTL2.CEnDLS3 to CEnCTL2.CEnDLS0 bits ( $n = 1, 0$ ).

**Figure 18-6. Transfer Data Length: 16 Bits (CEnCTL2.CEnDLS3 to CEnCTL2.CEnDLS0 bits = 0000),  
Transfer Direction: MSB First (CEnCTL0.CEnDIR bit = 0)**

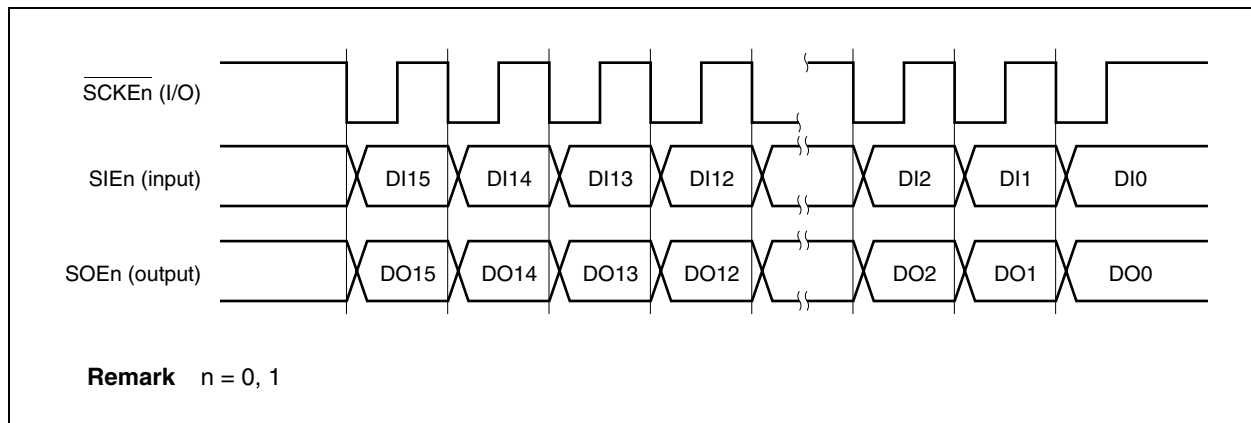

**(5) Function to select serial clock and data phase**

The serial clock and data phase can be changed by using the CEnCTL1.CEnCKP, CEnCTL1.CEnDAP bits (n = 0, 1).

**Figure 18-7. Clock Timing**

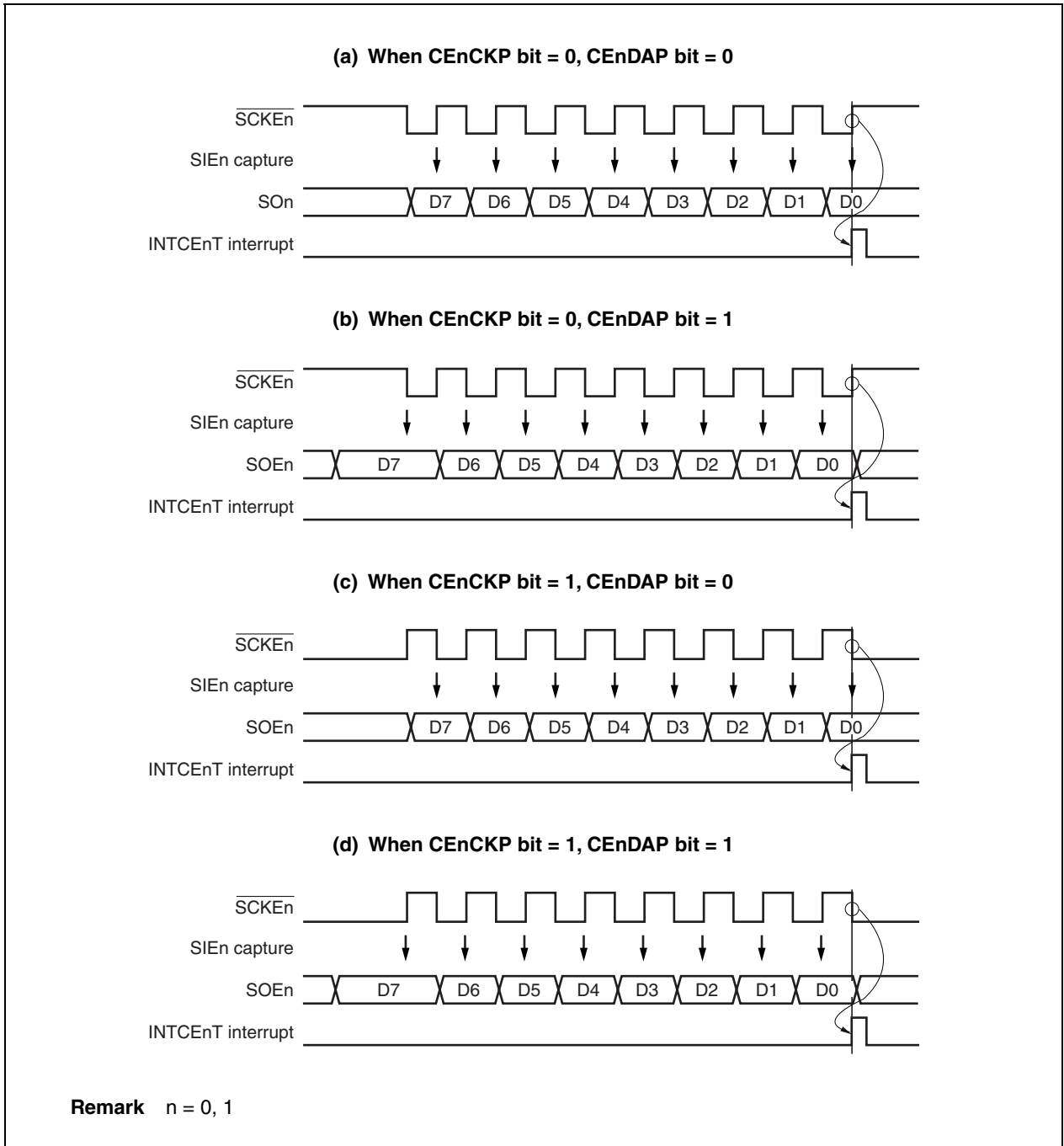

**(6) Master mode**

The master mode is set and data is transferred with the serial clock output to the CEnCTL1.CEnCKS2 to CEnCTL1.CEnCKS0 bits are set to a value other than 111 ( $\overline{\text{SCKEn}}$  pin input is invalid) ( $n = 0, 1$ ).

The default output level of the  $\overline{\text{SCKEn}}$  pin is high when the CEnCTL1.CEnCKP bit is 0, and low when the CEnCKP bit is 1.

**Figure 18-8. Master Mode (CEnCTL1.CEnCKP and CEnCTL1.CEnDAP bits = 00, CEnCTL2.CEnDLS3 to CEnCTL2.CEnDLS0 bits = 1000 (Transfer Data Length: 8 Bits))**

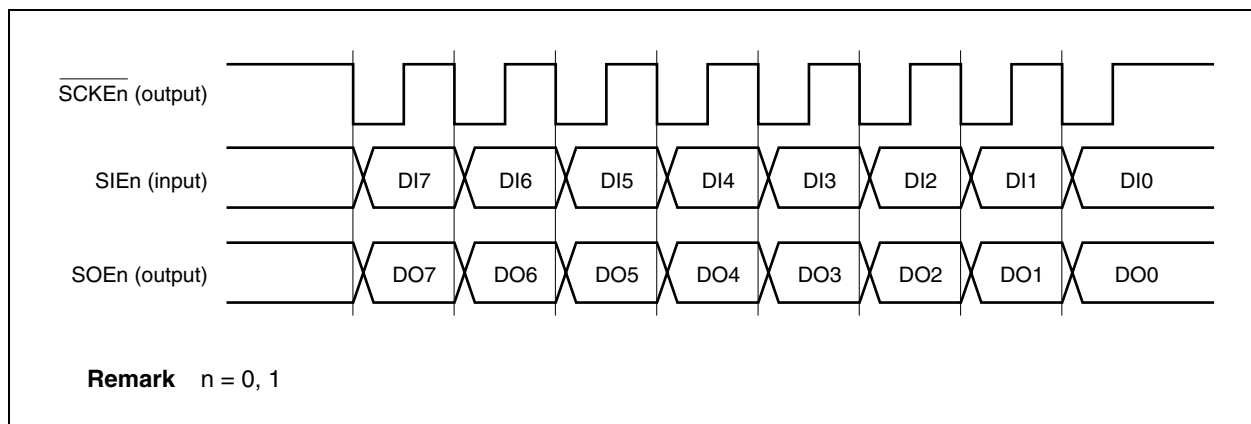

**(7) Slave mode**

The slave mode is set when the CEnCTL1.CEnCKS2 to CEnCTL1.CEnCKS0 bits are set to 111, and data is transferred with the serial clock input to the  $\overline{\text{SCKEn}}$  pin (in the slave mode, set the CEnCTL1.CEnMDL2 to CEnCTL1.CEnMDL0 bits to 000) ( $n = 0, 1$ ).

**Figure 18-9. Slave Mode (CEnCTL1.CEnCKP and CEnCTL1.CEnDAP bits = 00, CEnCTL2.CEnDLS3 to CEnCTL2.CEnDLS0 bits = 1000 (Transfer Data Length: 8 Bits))**

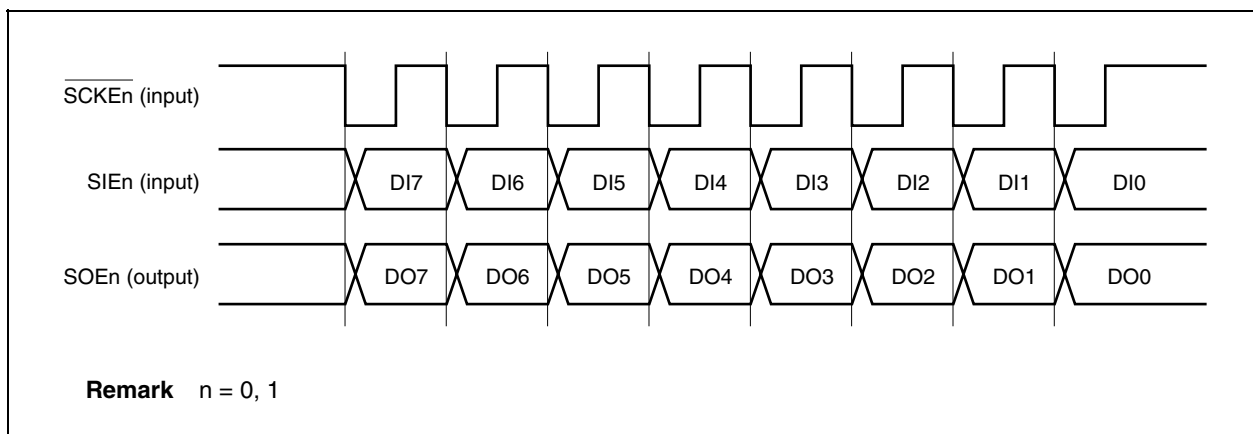
**(8) Transfer clock selection function**

In the master mode (CEnCTL1.CEnCKS2 to CEnCTL1.CEnCKS0 bits = other than 111 in the CEnCTL1 register), the bit transfer rate can be selected by setting the CEnCTL1.CEnCKS2 to CEnCTL1.CEnCKS0, CEnMDL2 to CEnMDL0 bits (see 18.4 (2) CSIE control register 1 (CEnCTL1)).

**(9) Single mode**

The single mode is set when the CEnCTL0.CEnTMS bit is 0 ( $n = 0, 1$ ).

In this mode, transfer is started when the CEnTXE bit or CEnRXE bit is set to 1 and when data is in the CSIBUFn register (CEnSTR.CEnEMF bit = 0).

If no data is in the CSIBUFn register (CEnEMF bit = 1), transfer is kept waiting until transmit data or dummy data is written to the CEnTX0 register.

When data is written to the CEnTX0 register while transmission or reception is enabled (CEnTXE or CEnRXE bit is 1), the CEnSTR.CEnTSF bit (transfer status flag) is set to 1. If transfer is not in the wait status, the transfer data indicated by the SIO<sub>n</sub> load CSIBUFn pointer is loaded from the CEnSTR.CEnTSF bit, and transfer processing is started.

If the read operation (CEnRX0 register read) of the previously received data has been completed before one data has been transferred in the reception mode or transmission/reception mode, the received data is stored from the SIO<sub>n</sub> register to the CEnRX0 register, the transmission/reception completion interrupt (INTCEnT) is output, and the SIO<sub>n</sub> load CSIBUFn pointer is incremented. If the read operation of the previously received data has not been completed, the wait status is set and storing the receive data in the CEnRX0 register, outputting the INTCEnT interrupt, and incrementing the SIO<sub>n</sub> load CSIBUFn pointer are held pending, until all previously received data is read output from the CEnRX0 register.

In the transmission mode, the INTCEnT interrupt is output and the SIO<sub>n</sub> load pointer is incremented when transfer processing of one data has been completed (the CEnRX0 register is always in the read complete status because no data is stored from the SIO<sub>n</sub> register to the CEnRX0 register).

In all modes (transmission, reception, and transmission/reception modes), if the CSIBUFn register is empty (write CSIBUFn pointer value = SIO<sub>n</sub> load CSIBUFn pointer value) when transfer processing of one data has been completed, the CEnTSF bit is cleared to 0. The value of the “number of remaining data in the CSIBUFn register (write CSIBUFn pointer – SIO<sub>n</sub> load pointer)” can always be read from the CEnSTR.CEnSFP3 to CEnSTR.CEnSFP0 bits.

**Caution** Be sure to confirm that the CEnSTR.CEnFLF register is 0 when writing data to the CEnTX0 register. Even if data is written to this register when CEnFLF bit is 1, the CSIBUFn overflow interrupt (INTCEnTIOF) is output, and the written data is ignored.

Figure 18-10. Single Mode

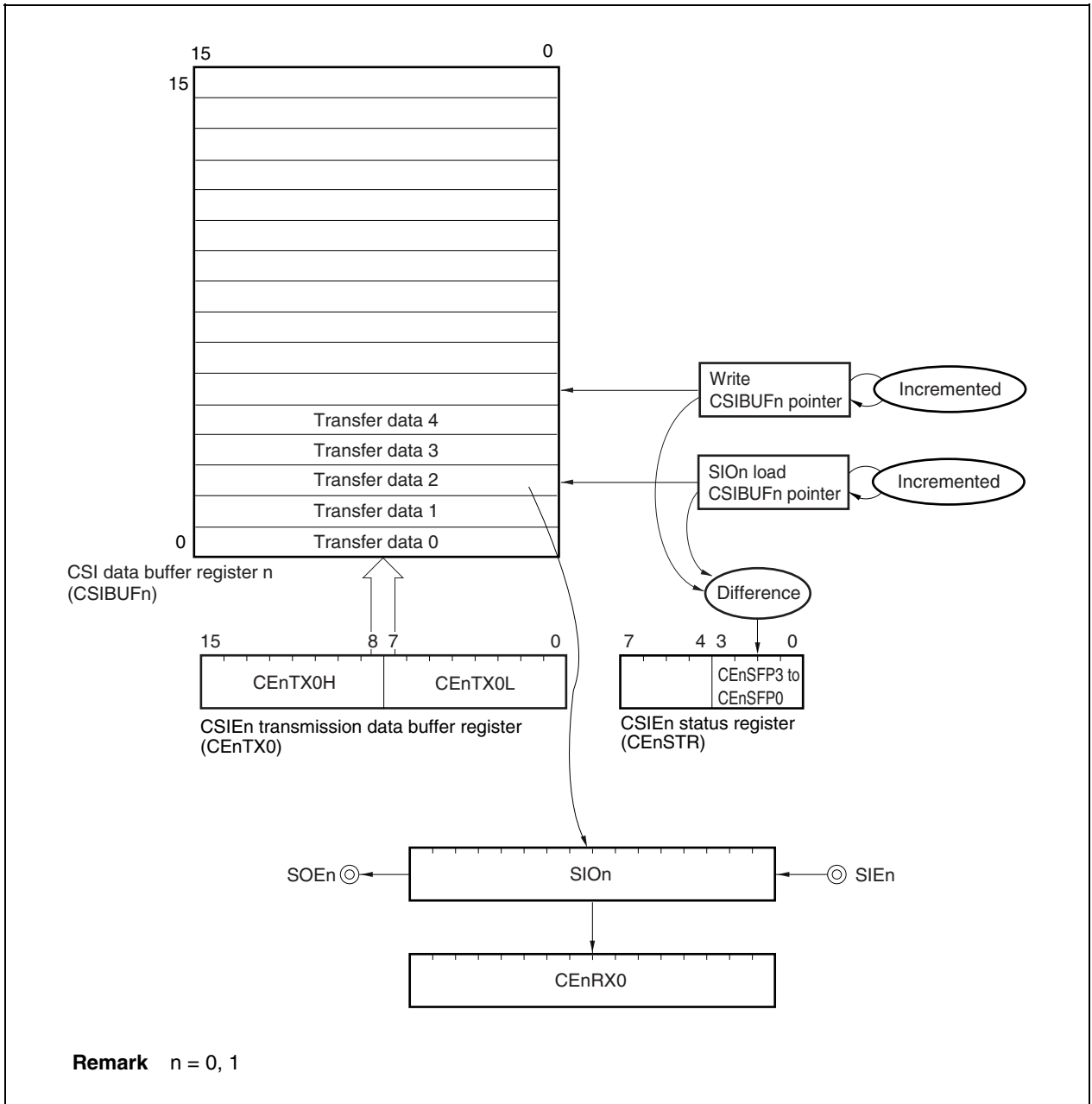

The transfer start conditions in single mode are shown below. CSIE<sub>n</sub> starts data transfer when these conditions are satisfied.

**Table 18-7. Transfer Start Conditions in Single Mode**

Transfer Mode		CEnTXE Bit	CEnRXE Bit	CSIBUF <sub>n</sub> Register	CEnRX0 Register, SIO <sub>n</sub> Register	$\overline{\text{SCKEn}}$ Pin
Master mode	Transmission mode	1	0	Untransferred data is present (CEnEMF bit = 0)	–	–
	Reception mode	0	1	Untransferred dummy data is present (CEnEMF bit = 0)	Received data has been transferred from SIO <sub>n</sub> register to CEnRX0 register	
	Transmission/reception mode	1	1	Untransferred data is present (CEnEMF bit = 0)		
Slave mode	Transmission mode	1	0	Untransferred data is present (CEnEMF bit = 0)	–	Input
	Reception mode	0	1	Untransferred dummy data is present (CEnEMF bit = 0)	Received data has been transferred from SIO <sub>n</sub> register to CEnRX0 register	
	Transmission/reception mode	1	1	Untransferred data is present (CEnEMF bit = 0)		

- Remarks**
1. CEnTXE bit: Bit 6 of CEnCTL0 register  
CEnRXE bit: Bit 5 of CEnCTL0 register  
CEnEMF bit: Bit 5 of CEnSTR register
  2. n = 0 or 1



**(10) Continuous mode**

The continuous mode is set when the CEnCTL0.CEnTMS bit is 1 ( $n = 0, 1$ ).

In this mode, transfer is started when the CEnTXE bit or CEnRXE bit is 1 and when data is in the CSIBUF $n$  register (CEnSTR.CEnEMF register). At this time, set the number of transfer data in advance by using the CEnCTL3.CEnSFN3 to CEnCTL3.CEnSFN0 bits. If data exceeding the number of transfer data specified by the CEnCTL3.CEnSFN3 to CEnCTL3.CEnSFN0 bits are written to the CSIBUF $n$  register, the excess data are ignored and not transferred.

If no data is in the CSIBUF $n$  register (CEnEMF bit = 1), transfer is kept waiting until transmit data or dummy data is written to the CEnTX0 register.

If data is written to the CEnTX0 register when transmission or reception is enabled (CEnTXE or CEnRXE bit is 1), the CEnSTR.CEnTSF bit (transfer status flag) is set to 1 and the transfer data indicated by the SIO $n$  load/store CSIBUF $n$  pointer is loaded from the CSIBUF $n$  register to SIO $n$  register. Then transfer processing is started.

When transfer processing of one data is completed in the reception mode or transmission/reception mode, the received data is overwritten from the SIO $n$  register to the transfer data in the CSIBUF $n$  register indicated by the SIO $n$  load/store CSIBUF $n$  pointer, and then the pointer is incremented. By consecutively reading the transfer data from the CEnRX0 register after all data in the CSIBUF $n$  register have been transferred (when the INTCE $n$ T interrupt has occurred), the receive data can be sequentially read while the read CSIBUF $n$  pointer is incremented. If read operation is executed for the data number exceeding the received data count from the CEnRX0 register, however, the read value is undefined.

In the transmission mode, the SIO $n$  load/store CSIBUF $n$  pointer is incremented when transfer processing of one data has been completed.

In all modes (transmission, reception, and transmission/reception modes), when data has been transferred by the value set by the CEnCTL3.CEnSFN3 to CEnCTL3.CEnSFN0 bits, the CEnTSF bit is cleared to 0 and the transmission/reception completion interrupt (INTCE $n$ T) is output.

To transfer the next data, be sure to write 1 to the CEnSTR.CEnPCT bit and clear all the CSIBUF $n$  pointers to 0.

The “number of transferred data (SIO $n$  load/store CSIBUF $n$  pointer value)” can always be read from the CEnSTR.CEnSFP3 to CEnSTR.CEnSFP0 bits.

**Caution** The CEnSTR register is in the same status when transfer data is written (before start of transfer) after the CSIBUF $n$  pointer is cleared (CEnSTR.CEnPCT bit = 1) and when 16 data have been transferred (CEnSTR.CEnSTR.CEnFLF bit = 0, CEnSTR.CEnEMF bit = 1, CEnSTR.CEnSFP3 to CEnSTR.CEnSFP0 bits = 0000).

Figure 18-11. Continuous Mode

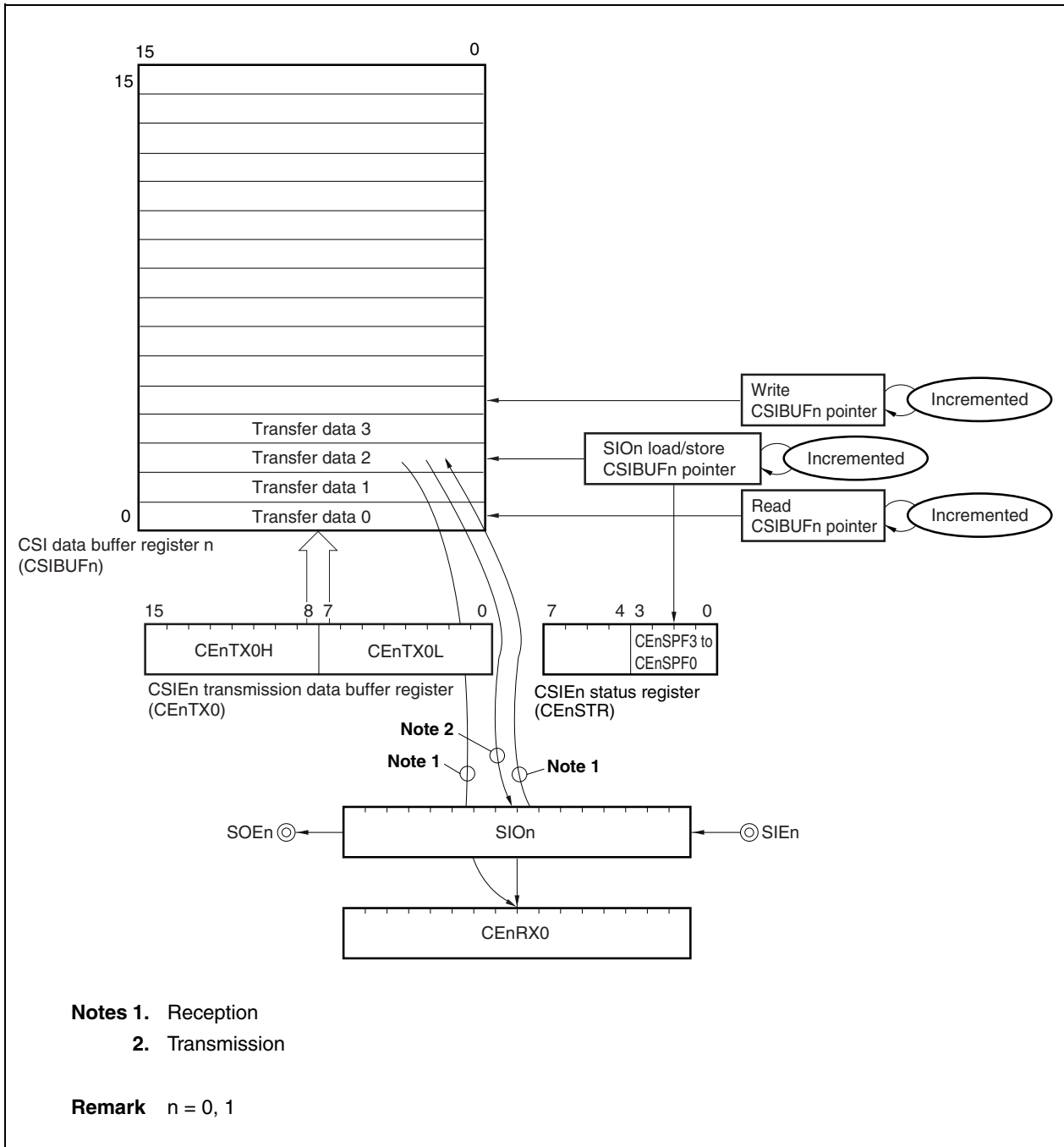

The transfer start conditions in continuous mode are shown below. CSIE<sub>n</sub> starts data transfer when these conditions are satisfied.

**Table 18-8. Transfer Start Conditions in Continuous Mode**

Transfer Mode		CEnTXE Bit	CEnRXE Bit	CSIBUF <sub>n</sub> Register	CEnRX0 Register, SIO <sub>n</sub> Register	$\overline{\text{SCKEn}}$ Pin	
Master mode	Transmission mode	1	0	Untransferred data is present (CEnEMF bit = 0)	–	–	
	Reception mode	0	1	Untransferred dummy data is present (CEnEMF bit = 0) <sup>Note</sup>			
	Transmission/reception mode	1	1	Untransferred data is present (CEnEMF bit = 0)			
Slave mode	Transmission mode	1	0	Untransferred data is present (CEnEMF bit = 0)		–	Input
	Reception mode	0	1	Untransferred dummy data is present (CEnEMF bit = 0) <sup>Note</sup>			
	Transmission/reception mode	1	1	Untransferred data is present (CEnEMF bit = 0)			

**Note** The same amount of dummy data as the data to be received is required.

- Remarks**
1. CEnTXE bit: Bit 6 of CEnCTL0 register  
 CEnRXE bit: Bit 5 of CEnCTL0 register  
 CEnEMF bit: Bit 5 of CEnSTR register
  2. n = 0 or 1

**(11) Transmission mode**

The transmission mode is set when the CEnCTL0.CEnTXE bit is set to 1 and the CEnRXE bit is cleared to 0. In this mode, transmission is started by a trigger that writes transmit data to the CEnTX0 register or sets the CEnTXE bit to 1 when transmit data is in the CSIBUFn register (n = 0, 1). The value input to the SIEn pin during transmission is latched in the shift register (SIOOn) but is not transferred to the CEnRX0 and CSIBUFn registers at the end of transmission.

The transmission/reception completion interrupt (INTCEnT) occurs immediately after data is sent out from the SIOOn register.

**(12) Reception mode**

The reception mode is set when the CEnCTL0.CEnTXE bit is cleared to 0 and the CEnCTL0.CEnRXE bit is set to 1. In this mode, reception is started by using the processing of writing dummy data to the CEnTX0 register as a trigger (n = 0, 1). In the single mode (CEnCTL0.CEnTMS bit = 1), however, the condition of starting reception includes that the receive data has been transferred from the SIOOn register to the CEnRX0 register. (If reception to the SIOOn register is completed when the previous receive data is held in the CEnRX0 register without being read, the receive data stored in the SIOOn register is transferred to the CEnRX0 register by reading the CEnRX0 register.) In the continuous mode, reception starts by writing dummy data of the number of receive data to the CEnTX0 register with the first dummy data write processing taken as a trigger.

The SOEn pin outputs a low level.

The transmission/reception completion interrupt (INTCEnT) occurs immediately after receive data is transferred from the SIOOn register to the CEnRX0 register.

**(13) Transmission/reception mode**

The transmission/reception mode is set when both the CEnCTL0.CEnTXE bit = 1 and the CEnCTL0.CEnRXE bit = 1. In this mode, transmission/reception is started by using the processing to write transmit data to the CEnTX0 register as a trigger (n = 0, 1). In the single mode (CEnCTL0.CEnTMS bit = 0), however, the condition of starting transmission/reception includes that the receive data has been transferred from the SIOOn register to the CEnRX0 register. (If reception to the SIOOn register is completed when the previously received data is held in the CEnRX0 register without being read, the receive data stored in the SIOOn register is transferred to the CEnRX0 register by reading the CEnRX0 register.)

**(14) Delay control of transmission/reception completion interrupt (INTCEnT)**

In the master mode (CEnCTL1.CEnCKS2 to CEnCTL1.CEnCKS0 bits = other than 111), occurrence of the transmission/reception completion interrupt (INTCEnT) can be delayed by half a clock (1/2 serial clock), depending on the setting (1) of the CEnCTL0.CEnTMS bit. The CEnSIT bit is valid only in the master mode. In the slave mode (CEnCTL1.CEnCKS2 to CEnCTL1.CEnCKS0 bits = 111), setting the CEnSIT bit to 1 is prohibited (even if set, the INTCEnT interrupt is not affected).

**Caution** If the CEnCTL0.CEnSIT bit is set to 1 in the continuous mode (CEnCTL0.CEnTMS bit = 1), the INTCEnT interrupt is not output at the end of data other than the last data set by the CEnCTL3.CEnSFN3 to CEnCTL3.CEnSFN0 bits, but a delay of half a clock (1/2 serial clock) can be inserted between each data transfer.

**Figure 18-12. Delay Control of Transmission/Reception Completion Interrupt (INTCEnT):**  
**CEnCTL0.CEnSIT Bit = 1, CEnCKP, CEnDAP Bits = 00,**  
**CEnCTL2.CEnDLS3 to CEnCTL2.CEnDLS0 Bits = 1000 (Transfer Data Length: 8 Bits)**

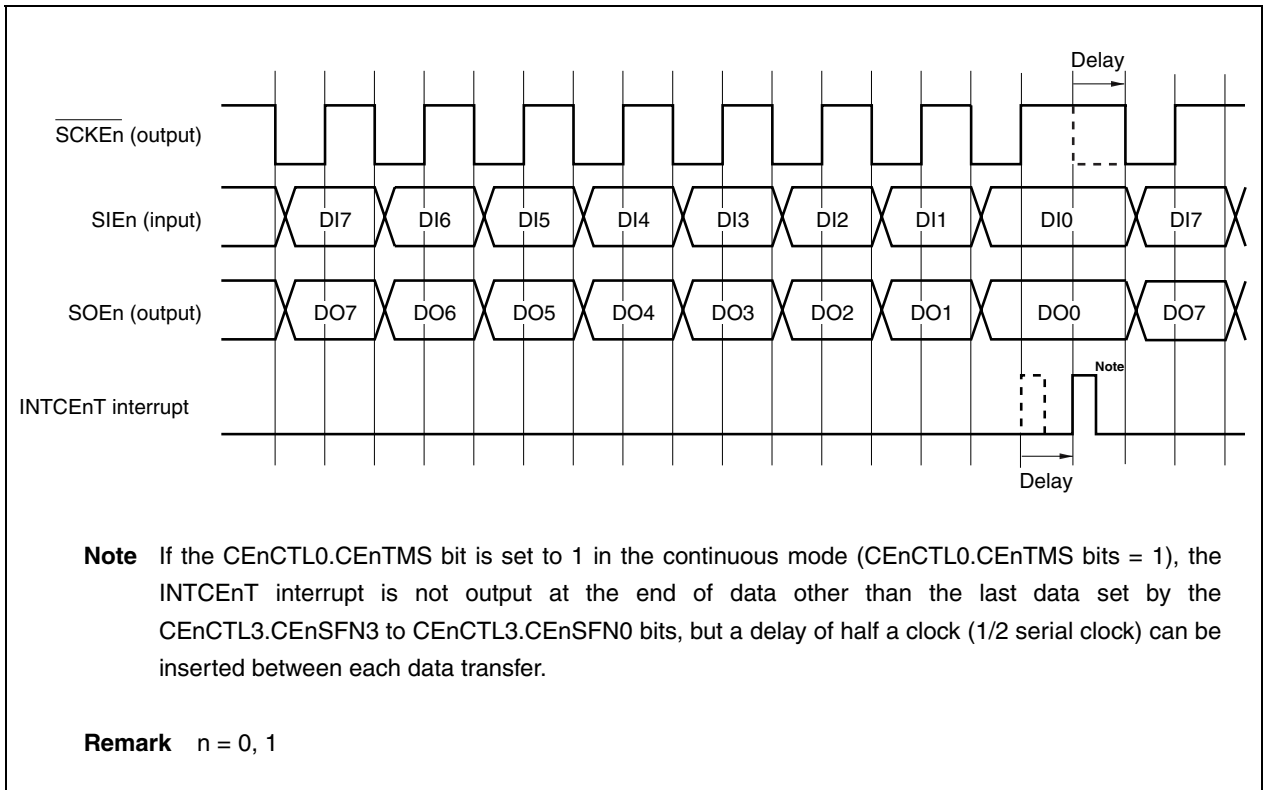

## (15) Output pins

(a)  $\overline{\text{SCKEn}}$  pin

The  $\overline{\text{SCKEn}}$  pin output status when the CSIE<sub>n</sub> does not perform transmission/reception.

Table 18-9.  $\overline{\text{SCKEn}}$  Pin Output Level in Non-Communication State

CEnPWR Bit	CEnPCT Bit	CEnCKP Bit	CEnTXE, CEnRXE Bits	CEnCKS2 to CEnCKS0 Bits	$\overline{\text{SCKEn}}$ Pin Output Level
0	–	–	–	111 (slave mode)	High impedance
				Other than 111 (master mode)	High level
1	0 → 1 After setting	0	–	111 (slave mode)	High impedance
				Other than 111 (master mode)	High level
		1		111 (slave mode)	High impedance
				Other than 111 (master mode)	Low level
	–	0	Changes to 00B <sup>Note 1</sup>	111 (slave mode)	High impedance
				Other than 111 (master mode)	High level
			Other than above	111 (slave mode)	High impedance
				Other than 111 (master mode)	<b>Note 3</b>
		1	Changes from 00B <sup>Note 2</sup>	111 (slave mode)	High impedance
				Other than 111 (master mode)	Low level
			Other than above	111 (slave mode)	High impedance
				Other than 111 (master mode)	<b>Note 3</b>

- Notes**
1. When the values set to the CEnTXE and CEnRXE bits change from 01 to 00, 10 to 00, or 11 to 00.
  2. When the values set to the CEnTXE and CEnRXE bits change from 00 to 01, 00 to 10, or 00 to 11.
  3. The previous  $\overline{\text{SCKEn}}$  pin output level is retained (the  $\overline{\text{SCKEn}}$  pin output level does not change).

**Remark** n = 0, 1

**Caution** If the CEnCKP bit is set to 1 in the master mode (CEnCKS2 to CEnCKS0 bits are other than 111), the  $\overline{\text{SCKEn}}$  pin outputs a low level when it is inactive. If the CEnCTL0.CEnTXE bit is cleared to 0 (disabling transmission) and CEnRXE bit is cleared to 0 (disabling reception), the  $\overline{\text{SCKEn}}$  pin outputs a high level.

Therefore, take the following measures to fix the  $\overline{\text{SCKEn}}$  pin to low level when CSIE<sub>n</sub> is not used.

[ $\overline{\text{SCKE0}}$  pin ( $\overline{\text{SCKE1}}$  pin)]

- <1> Clearing the P6.P62 bit to 0 (clearing the P6.P65 bit to 0):  
The port output level is set to low.
- <2> Clearing the PM6.PM62 bit to 0 (clearing the PM6.PM65 bit register to 0):  
The port is set in the output mode.
- <3> Clearing the PMC6.PMC62 to 0 (clearing the PMC6.PMC65 bit to 0):  
The pin is set in the port mode (fixed to low-level output).
- <4> Clearing the CE0CTL0.CE0TXE and CE0CTL0.CE0RXE bits to 0  
(clearing the CE1CTL0.CE1TXE and CE1CTL0.CE1RXE bits to 0):  
Transmission and reception are disabled.
- <5> Setting the CE0STR.CE0PCT bit to 1 (setting the CE1STR.CE1PCT bit to 1):  
Clearing all pointers for CSIBUF0 (CSIBUF1).

- <6> Setting the CE0CTL0.CE0TXE or CE0CTL0.CE0RXE bit to 1 (setting the CE1CTL0.CE1TXE or CE1CTL0.CE1RXE bit to 1):  
Transmission or reception is enabled (both transmission/reception can also be enabled).
- <7> Setting the PMC6.PMC62 bit to 1 (setting the PMC6.PMC65 bit to 1):  
The pin is set as the alternate function ( $\overline{\text{SCKE0}}$  and  $\overline{\text{SCKE1}}$  pin outputs).

Because the register set values <1> and <2> are retained, control can be performed only by <3> to <7> once they have been set.

**(b) SOEn pin**

The SOEn pin output status when the CSIE does not perform transmission/reception.

**Table 18-10. SOEn Pin Output Level in Non-Communication State**

CEnPWR Bit	CEnPCT Bit	CEnDAP Bit	CEnTXE Bit	CEnCKS2 to CEnCKS0 Bits	SOEn Pin Output Level
0	–	–	–	–	Low level
1	0 → 1 After setting	0	–	111 (slave mode)	<b>Note</b>
				Other than 111 (master mode)	Low level
		1		–	Low level
	–	–	1 → 0	–	Low level
			0 → 1		<b>Note</b>

**Note** The previous SOEn pin output level is retained (the SOEn pin output level does not change).

**Remark** n = 0, 1

**(16) CSIBUFn overflow interrupt signal (INTCEnTIOF)**

In the single mode and continuous mode, the INTCEnTIOF interrupt is output when 16 untransmitted data exist in the CSIBUFn register and when the 17th data is written (to the CEnTX0 or CEnTX0L register) (the 17th transfer data is not written but ignored).

In the single mode (CEnCTL0.CEnTMS bit = 0), 16 untransmitted data exist in the CSIBUFn register when “write CSIBUFn pointer value = SIO load CSIBUFn pointer value and CEnSTR.CEnFLF bit = 1”. When transfer is completed and the SIO load CSIBUFn pointer is incremented, the CSIBUFn register can write one transmission data.

Writing the next transmission data to the CSIBUFn register is not available even when transfer of one data has been completed in the continuous mode (CEnCTL0.CEnTMS bit = 1).

## 18.7 How to Use

### (1) Single mode (in master mode and transmission mode)

- <1> When the CEnCTL0.CEnPWR register is set to 1, supplying the operating clock is enabled.
- <2> Specify the transfer mode by setting the CEnCTL1 and CEnCTL2 registers.
- <3> Write 1 to the CEnSTR.CEnPCT bit to clear all the CSIBUFn pointers to 0.
- <4> Confirm that the CEnSTR.CEnFLF bit = 0, CEnSTR.CEnEMF bit = 1, and CEnSTR.CEnSFP3 to CEnSFP0 bits = 0000.
- <5> Specify the transfer mode by using the CEnCTL0.CEnTMS, CEnCTL0.CEnDIR, and CEnCTL0.CEnSIT bits and, at the same time, enable transmission by setting the CEnTXE bit to 1.
- <6> Confirm that the CEnSTR.CEnFLF register is 0, and then write transfer data to the CEnTX0 register. If it is clearly known that the CEnFLF bit is 0 because transfer data is written to that bit by the interrupt servicing routine of INTCEnt, it is not always necessary to confirm that the CEnFLF bit is 0.
- <7> Confirm that the INTCEnt interrupt has occurred and the CEnSTR.CEnEMF bit is 1, and disable transmission by clearing the CEnCTL0.CEnTXE bit to 0 (end of transmission).

**Caution** To execute further transfer, repeat <6> before <7>.

### (2) Single mode (in master mode and reception mode)

- <1> When the CEnCTL0.CEnPWR register is set to 1, supplying the operating clock is enabled.
- <2> Specify the transfer mode by setting the CEnCTL1 and CEnCTL2 registers.
- <3> Write 1 to the CEnSTR.CEnPCT bit to clear all the CSIBUFn pointers to 0.
- <4> Confirm that the CEnSTR.CEnFLF bit = 0, CEnSTR.CEnEMF bit = 1, and CEnSTR.CEnSFP3 to CEnSFP0 bits = 0000.
- <5> Specify the transfer mode by using the CEnCTL0.CEnTMS, CEnCTL0.CEnDIR, and CEnCTL0.CEnSIT bits and, at the same time, enable reception by setting the CEnRXE bit to 1.
- <6> Confirm that the CEnSTR.CEnFLF register is 0, and then write dummy transfer data to the CEnTX0 register (reception start trigger). If it is clearly known that the CEnFLF bit is 0 because dummy transfer data is written to that bit by the interrupt servicing routine of INTCEnt, it is not always necessary to confirm that the CEnFLF bit is 0.
- <7> Confirm that the INTCEnt interrupt has occurred, and then read the CEnRX0 register.
- <8> Confirm that the INTCEnt interrupt has occurred and the CEnEMF bit is 1, and disable reception by clearing the CEnCTL0.CEnRXE bit to 0 (end of reception).

**Cautions** 1. To execute further transfer, repeat <6> and <7> before <8>.  
2. The SOEn pin outputs a low level but this is invalid.



**(3) Single mode (in master mode and transmission/reception mode)**

- <1> When the CEnCTL0.CEnPWR register is set to 1, supplying the operating clock is enabled.
- <2> Specify the transfer mode by setting the CEnCTL1 and CEnCTL2 registers.
- <3> Write 1 to the CEnSTR.CEnPCT bit to clear all the CSIBUFn pointers to 0.
- <4> Confirm that the CEnSTR.CEnFLF bit = 0, CEnSTR.CEnEMF bit = 1, and CEnSTR.CEnSFP3 to CEnSFP0 bits = 0000.
- <5> Specify the transfer mode by using the CEnCTL0.CEnTMS, CEnCTL0.CEnDIR, and CEnCTL0.CEnSIT bits and, at the same time, enable transmission/reception by setting the CEnTXE and CEnRXE bits to 1.
- <6> Confirm that the CEnSTR.CEnFLF register is 0, and then write transfer data to the CEnTX0 register. If it is clearly known that the CEnFLF bit is 0 because transfer data is written to that bit by the interrupt servicing routine of INTCEnt, it is not always necessary to confirm that the CEnFLF bit is 0.
- <7> Confirm that the INTCEnt interrupt has occurred, and then read the CEnRX0 register.
- <8> Confirm that the INTCEnt interrupt has occurred and the CEnEMF bit is 1, and disable transmission/reception by clearing the CEnCTL0.CEnTXE bit = 0 and CEnCTL0.CEnRXE bit = 0 register to 0 (end of transmission/reception).

**Caution** To execute further transfer, repeat <6> and <7> before <8>.

**(4) Single mode (in slave mode and transmission mode)**

- <1> When the CEnCTL0.CEnPWR register is set to 1, supplying the operating clock is enabled.
- <2> Specify the transfer mode by setting the CEnCTL1 and CEnCTL2 registers.
- <3> Write 1 to the CEnSTR.CEnPCT bit to clear all the CSIBUFn pointers to 0.
- <4> Confirm that the CEnSTR.CEnFLF bit = 0, CEnSTR.CEnEMF bit = 1, and CEnSTR.CEnSFP3 to CEnSFP0 bits = 0000.
- <5> Specify the transfer mode by using the CEnCTL0.CEnTMS, CEnCTL0.CEnDIR, and CEnCTL0.CEnSIT bits and, at the same time, enable transmission by setting the CEnTXE bit to 1.
- <6> Confirm that the CEnSTR.CEnFLF register is 0, and then write transfer data to the CEnTX0 register. If it is clearly known that the CEnFLF bit is 0 because transfer data is written to that bit by the interrupt servicing routine of INTCEnt, it is not always necessary to confirm that the CEnFLF bit is 0.
- <7> Confirm that the INTCEnt interrupt has occurred and the CEnEMF bit is 1, and disable transmission by clearing the CEnCTL0.CEnTXE bit to 0 (end of transmission).

**Caution** To execute further transfer, repeat <6> before <7>.

**(5) Single mode (in slave mode and reception mode)**

- <1> When the CEnCTL0.CEnPWR register is set to 1, supplying the operating clock is enabled.
- <2> Specify the transfer mode by setting the CEnCTL1 and CEnCTL2 registers.
- <3> Write 1 to the CEnSTR.CEnPCT bit to clear all the CSIBUFn pointers to 0.
- <4> Confirm that the CEnSTR.CEnFLF bit = 0, CEnSTR.CEnEMF bit = 1, and CEnSTR.CEnSFP3 to CEnSFP0 bits = 0000.
- <5> Specify the transfer mode by using the CEnCTL0.CEnTMS, CEnCTL0.CEnDIR, and CEnCTL0.CEnSIT bits and, at the same time, enable reception by setting the CEnRXE bit to 1.
- <6> Confirm that the CEnSTR.CEnFLF register is 0, and then write dummy transfer data to the CEnTX0 register (reception start trigger). If it is clearly known that the CEnFLF bit is 0 because dummy transfer data is written to that bit by the interrupt servicing routine of INTCEnT, it is not always necessary to confirm that the CEnFLF bit is 0.
- <7> Confirm that the INTCEnT interrupt has occurred, and then read the CEnRX0 register.
- <8> Confirm that the INTCEnT interrupt has occurred and the CEnEMF bit is 1, and disable reception by clearing the CEnCTL0.CEnRXE bit to 0 (end of reception).

- Cautions 1. To execute further transfer, repeat <6> and <7> before <8>.**  
**2. The SOEn pin outputs a low level but this is invalid.**

**(6) Single mode (in slave mode and transmission/reception mode)**

- <1> When the CEnCTL0.CEnPWR register is set to 1, supplying the operating clock is enabled.
- <2> Specify the transfer mode by setting the CEnCTL1 and CEnCTL2 registers.
- <3> Write 1 to the CEnSTR.CEnPCT bit to clear all the CSIBUFn pointers to 0.
- <4> Confirm that the CEnSTR.CEnFLF bit = 0, CEnSTR.CEnEMF bit = 1, and CEnSTR.CEnSFP3 to CEnSFP0 bits = 0000.
- <5> Specify the transfer mode by using the CEnCTL0.CEnTMS, CEnCTL0.CEnDIR, and CEnCTL0.CEnSIT bits and, at the same time, enable transmission/reception by setting the CEnTXE and CEnRXE bits to 1.
- <6> Confirm that the CEnSTR.CEnFLF register is 0, and then write transfer data to the CEnTX0 register. If it is clearly known that the CEnFLF bit is 0 because transfer data is written to that bit by the interrupt servicing routine of INTCEnT, it is not always necessary to confirm that the CEnFLF bit is 0.
- <7> Confirm that the INTCEnT interrupt has occurred, and then read the CEnRX0 register.
- <8> Confirm that the INTCEnT interrupt has occurred and the CEnEMF bit is 1, and disable transmission/reception by clearing the CEnCTL0.CEnTXE bit = 0 and CEnCTL0.CEnRXE bit = 0 register to 0 (end of transmission/reception).

- Caution To execute further transfer, repeat <6> and <7> before <8>.**

**(7) Continuous mode (in master mode and transmission mode)**

- <1> When the CEnCTL0.CEnPWR register is set to 1, supplying the operating clock is enabled.
- <2> Specify the transfer mode by setting the CEnCTL1 and CEnCTL2 registers.
- <3> Write 1 to the CEnSTR.CEnPCT bit to clear all the CSIBUFn pointers to 0.
- <4> Confirm that the CEnSTR.CEnFLF bit = 0, CEnSTR.CEnEMF bit = 1, and CEnSTR.CEnSFP3 to CEnSFP0 bits = 0000.
- <5> Specify the transfer mode by using the CEnCTL0.CEnTMS, CEnCTL0.CEnDIR, and CEnCTL0.CEnSIT bits and, at the same time, enable transmission by setting the CEnTXE bit to 1.
- <6> Set the amount of data to be transmitted by using the CEnCTL3.CEnSFN3 to CEnCTL3.CEnSFN0 bits.
- <7> Write the amount of data to be transmitted to the CEnTX0 register as transfer data. Writing data exceeding the set value of the CEnCTL3 register is prohibited.
- <8> Confirm that the INTCEnT interrupt has occurred and the CEnEMF bit is 1. Then write 1 to the CEnSTR.CEnPCT bit, and clear all the CSIBUFn pointers to 0 in preparation for the next transfer.
- <9> Confirm that the CEnSTR.CEnFLF bit = 0, CEnSTR.CEnEMF bit = 1, and CEnSTR.CEnSFP3 to CEnSFP0 bits = 0000.
- <10> Disable transmission by clearing the CEnCTL0.CEnTXE bit to 0 (end of transmission).

**Caution** To execute further transfer, repeat <6> to <9> before <10>.

**(8) Continuous mode (in master mode and reception mode)**

- <1> When the CEnCTL0.CEnPWR register is set to 1, supplying the operating clock is enabled.
- <2> Specify the transfer mode by setting the CEnCTL1 and CEnCTL2 registers.
- <3> Write 1 to the CEnSTR.CEnPCT bit to clear all the CSIBUFn pointers to 0.
- <4> Confirm that the CEnSTR.CEnFLF bit = 0, CEnSTR.CEnEMF bit = 1, and CEnSTR.CEnSFP3 to CEnSFP0 bits = 0000.
- <5> Specify the transfer mode by using the CEnCTL0.CEnTMS, CEnCTL0.CEnDIR, and CEnCTL0.CEnSIT bits and, at the same time, enable reception by setting the CEnRXE bit to 1.
- <6> Set the amount of data to be received by using the CEnCTL3.CEnSFN3 to CEnCTL3.CEnSFN0 bits.
- <7> Write dummy transfer data of the number of receive data to the CEnTX0 register. The first dummy transfer data write is the trigger to start reception. Writing dummy data exceeding the set value of the CEnCTL3 register is prohibited.
- <8> Confirm that the INTCEnT interrupt has occurred and the CEnEMF bit is 1. Then read the receive data from the CEnRX0 register (sequentially read the receive data stored in the CSIBUFn register).
- <9> Write 1 to the CEnSTR.CEnPCT bit, and clear all the CSIBUFn pointers to 0 in preparation for the next transfer.
- <10> Confirm that the CEnSTR.CEnFLF bit = 0, CEnSTR.CEnEMF bit = 1, and CEnSTR.CEnSFP3 to CEnSFP0 bits = 0000.
- <11> Disable reception by clearing the CEnCTL0.CEnRXE bit to 0 (end of reception).

**Cautions** 1. To execute further transfer, repeat <6> to <10> before <11>.

2. The SOEn pin outputs a low level.

**(9) Continuous mode (in master mode and transmission/reception mode)**

- <1> When the CEnCTL0.CEnPWR register is set to 1, supplying the operating clock is enabled.
- <2> Specify the transfer mode by setting the CEnCTL1 and CEnCTL2 registers.
- <3> Write 1 to the CEnSTR.CEnPCT bit to clear all the CSIBUFn pointers to 0.
- <4> Confirm that the CEnSTR.CEnFLF bit = 0, CEnSTR.CEnEMF bit = 1, and CEnSTR.CEnSFP3 to CEnSFP0 bits = 0000.
- <5> Specify the transfer mode by using the CEnCTL0.CEnTMS, CEnCTL0.CEnDIR, and CEnCTL0.CEnSIT bits and, at the same time, enable transmission/reception by setting both the CEnTXE and CEnRXE bits to 1.
- <6> Set the amount of data to be transmitted/received by using the CEnCTL3.CEnSFN3 to CEnCTL3.CEnSFN0 bits.
- <7> Write the amount of data to be transmitted to the CEnTX0 register as transfer data. Writing data exceeding the set value of the CEnCTL3 register is prohibited.
- <8> Confirm that the INTCEnt interrupt has occurred and the CEnEMF bit is 1. Then read the receive data from the CEnRX0 register (sequentially read the receive data stored in the CSIBUFn register).
- <9> Write 1 to the CEnSTR.CEnPCT bit, and clear all the CSIBUFn pointers to 0 in preparation for the next transfer.
- <10> Confirm that the CEnSTR.CEnFLF bit = 0, CEnSTR.CEnEMF bit = 1, and CEnSTR.CEnSFP3 to CEnSFP0 bits = 0000.
- <11> Disable transmission/reception by clearing the CEnCTL0.CEnTXE bit = 0 and CEnCTL0.CEnRXE bit = 0 register to 0 (end of transmission/reception).

**Caution** To execute further transfer, repeat <6> to <10> before <11>.

**(10) Continuous mode (in slave mode and transmission mode)**

- <1> When the CEnCTL0.CEnPWR register is set to 1, supplying the operating clock is enabled.
- <2> Specify the transfer mode by setting the CEnCTL1 and CEnCTL2 registers.
- <3> Write 1 to the CEnSTR.CEnPCT bit to clear all the CSIBUFn pointers to 0.
- <4> Confirm that the CEnSTR.CEnFLF bit = 0, CEnSTR.CEnEMF bit = 1, and CEnSTR.CEnSFP3 to CEnSFP0 bits = 0000.
- <5> Specify the transfer mode by using the CEnCTL0.CEnTMS, CEnCTL0.CEnDIR, and CEnCTL0.CEnSIT bits and, at the same time, enable transmission by setting the CEnTXE bit to 1.
- <6> Set the amount of data to be transmitted by using the CEnCTL3.CEnSFN3 to CEnCTL3.CEnSFN0 bits.
- <7> Write the amount of data to be transmitted to the CEnTX0 register as transfer data. Writing data exceeding the set value of the CEnCTL3 register is prohibited.
- <8> Confirm that the INTCEnt interrupt has occurred and the CEnEMF bit is 1. Then write 1 to the CEnSTR.CEnPCT bit, and clear all the CSIBUFn pointers to 0 in preparation for the next transfer.
- <9> Confirm that the CEnSTR.CEnFLF bit = 0, CEnSTR.CEnEMF bit = 1, and CEnSTR.CEnSFP3 to CEnSFP0 bits = 0000.
- <10> Disable transmission by clearing the CEnCTL0.CEnTXE bit to 0 (end of transmission).

**Caution** To execute further transfer, repeat <6> to <9> before <10>.

**(11) Continuous mode (in slave mode and reception mode)**

- <1> When the CEnCTL0.CEnPWR register is set to 1, supplying the operating clock is enabled.
- <2> Specify the transfer mode by setting the CEnCTL1 and CEnCTL2 registers.
- <3> Write 1 to the CEnSTR.CEnPCT bit to clear all the CSIBUFn pointers to 0.
- <4> Confirm that the CEnSTR.CEnFLF bit = 0, CEnSTR.CEnEMF bit = 1, and CEnSTR.CEnSFP3 to CEnSFP0 bits = 0000.
- <5> Specify the transfer mode by using the CEnCTL0.CEnTMS, CEnCTL0.CEnDIR, and CEnCTL0.CEnSIT bits and, at the same time, enable reception by setting the CEnRXE bit to 1.
- <6> Set the amount of data to be received by using the CEnCTL3.CEnSFN3 to CEnCTL3.CEnSFN0 bits.
- <7> Write dummy transfer data of the number of receive data to the CEnTX0 register. The first dummy transfer data write is the trigger to start reception. Writing dummy data exceeding the set value of the CEnCTL3 register is prohibited.
- <8> Confirm that the INTCEnT interrupt has occurred and the CEnEMF bit is 1. Then read the receive data from the CEnRX0 register (sequentially read the receive data stored in the CSIBUFn register).
- <9> Write 1 to the CEnSTR.CEnPCT bit, and clear all the CSIBUFn pointers to 0 in preparation for the next transfer.
- <10> Confirm that the CEnSTR.CEnFLF bit = 0, CEnSTR.CEnEMF bit = 1, and CEnSTR.CEnSFP3 to CEnSFP0 bits = 0000.
- <11> Disable reception by clearing the CEnCTL0.CEnRXE bit to 0 (end of reception).

- Cautions**
1. To execute further transfer, repeat <6> to <10> before <11>.
  2. The SOEn pin outputs a low level.

**(12) Continuous mode (in slave mode and transmission/reception mode)**

- <1> When the CEnCTL0.CEnPWR register is set to 1, supplying the operating clock is enabled.
- <2> Specify the transfer mode by setting the CEnCTL1 and CEnCTL2 registers.
- <3> Write 1 to the CEnSTR.CEnPCT bit to clear all the CSIBUFn pointers to 0.
- <4> Confirm that the CEnSTR.CEnFLF bit = 0, CEnSTR.CEnEMF bit = 1, and CEnSTR.CEnSFP3 to CEnSFP0 bits = 0000.
- <5> Specify the transfer mode by using the CEnCTL0.CEnTMS, CEnCTL0.CEnDIR, and CEnCTL0.CEnSIT bits and, at the same time, enable transmission/reception by setting both the CEnTXE and CEnRXE bits to 1.
- <6> Set the number of data to be transmitted/received by using the CEnCTL3.CEnSFN3 to CEnCTL3.CEnSFN0 bits.
- <7> Write the amount of data to be transmitted to the CEnTX0 register as transfer data. Writing data exceeding the set value of the CEnCTL3 register is prohibited.
- <8> Confirm that the INTCEnt interrupt has occurred and the CEnEMF bit is 1. Then read the receive data from the CEnRX0 register (sequentially read the receive data stored in the CSIBUFn register).
- <9> Write 1 to the CEnSTR.CEnPCT bit, and clear all the CSIBUFn pointers to 0 in preparation for the next transfer.
- <10> Confirm that the CEnSTR.CEnFLF bit = 0, CEnSTR.CEnEMF bit = 1, and CEnSTR.CEnSFP3 to CEnSFP0 bits = 0000.
- <11> Disable transmission/reception by clearing the CEnCTL0.CEnTXE bit = 0 and CEnCTL0.CEnRXE bit = 0 register to 0 (end of transmission/reception).

**Caution** To execute further transfer, repeat <6> to <10> before <11>.

## 18.8 Cautions

Cautions concerning CSIE<sub>n</sub> are shown below (n = 0, 1).

### (1) Stopping CSIE<sub>n</sub>

The CSIE<sub>n</sub> unit is reset and CSIE<sub>n</sub> is stopped when the CEnCTL0.CEnPWR bit is cleared to 0. To operate CSIE<sub>n</sub>, first set the CEnPWR bit to 1.

Usually, before clearing the CEnPWR bit to 0, clear both the CEnTXE and CEnRXE bits to 0 (after the end of transfer).

### (2) Enabling transfer

Be sure to write 1 to the CEnSTR.CEnPCT bit to clear all the CSIBUF<sub>n</sub> pointers to 0 before enabling transfer by setting the CEnCTL0.CEnPWR bits to 1. If the CEnTXE or CEnRXE bit is set to 1 without clearing the pointers, and if the previously transferred data remains in the CSIBUF<sub>n</sub> register, transferring that data is immediately started.

If transfer data is set to the CSIBUF<sub>n</sub> register before transfer is enabled, transfer is started as soon as the CEnTXE or CEnRXE bit is set to 1.

### (3) Caution on CEnCTL0 register setting

Be sure to set the port pins related to the CSIE<sub>n</sub> function to the alternate-function mode before using CSIE<sub>n</sub>. Then set the CEnPWR bit to 1 before setting the other bits.

### (4) Writing data to CEnTX0 register in single mode

Be sure to confirm that the CEnSTR.CEnFLF register is 0 when writing data to the CEnTX0 register. Even if data is written to this register when the CEnFLF bit is 1, the CSIBUF<sub>n</sub> overflow interrupt (INTCEnTIOF) is issued, and the written data is ignored.

### (5) CEnSTR register status in continuous mode

The CEnSTR register is in the same status when transfer data is written (before start of transfer) after the CSIBUF<sub>n</sub> pointer is cleared (CEnSTR.CEnPCT bit = 1) and when 16 data have been transferred (CEnSTR.CEnFLF bit = 0, CEnSTR.CEnEMF bit = 1, CEnSTR.CEnSFP3 to CEnSTR.CEnSFP0 bits = 0000).

### (6) Switching DMA transfer start factor

In the V850E/SJ3-H and V850E/SK3-H, DMA transfer start factor signals INTCE0T and INTERR are shared and cannot be used at the same time. This is also the case for DMA transfer start factor signals INTCE1T and INTSTA. When using the INTCE0T or INTCE1T signal as the DMA transfer start factor, set the DTFROB0 bit to 1 using the option byte 0000007AH (refer to **CHAPTER 33 OPTION BYTE FUNCTION** for details). In this case, the INTERR and INTSTA signals cannot be used as DMA transfer start factors.

**Remark** For details, see **Table 22-1 DMA Transfer Start Factors**.

## CHAPTER 19 I<sup>2</sup>C BUS

<R> To use the I<sup>2</sup>C bus function, use the P38/SDA00, P39/SCL00, P40/SDA01, P41/SCL01, P90/SDA02, P91/SCL02, P614/SDA03, P615/SCL03, P00/SDA04<sup>Note</sup>, P20/SDA04 (V850E/SK3-H only), P01/SCL04<sup>Note</sup>, P21/SCL04 (V850E/SK3-H only), P67/SDA05<sup>Note</sup>, P82/SDA05 (V850E/SK3-H only), P68/SCL05<sup>Note</sup>, and P83/SCL05 (V850E/SK3-H only) pins as alternate functions and set them to N-ch open-drain output.

<R> **Note** Not available in the  $\mu$ PD70F3931 (V850E/SJ3-H), 70F3932 (V850E/SJ3-H), and 70F3933 (V850E/SJ3-H).

The V850E/SJ3-H and V850E/SK3-H have an I<sup>2</sup>C bus.

The number of channels differs depending on the product in the V850E/SJ3-H and V850E/SK3-H as shown in the table below.

<R> **Table 19-1. Number of Channels Available for I<sup>2</sup>C Bus**

Product	V850E/SJ3-H		V850E/SK3-H
	Only $\mu$ PD70F3931, 70F3932, 70F3933	Other than $\mu$ PD70F3931, 70F3932, 70F3933	
Channel	4 channels (I <sup>2</sup> C00 to I <sup>2</sup> C03)	6 channels (I <sup>2</sup> C00 to I <sup>2</sup> C05)	



19.1 Port Settings of I<sup>2</sup>C00 to I<sup>2</sup>C05

## 19.1.1 For V850E/SJ3-H

Table 19-2. Pin Configuration

Mode	Pin Name	Alternate-Function Pin					
		Port <1>			Port <2>		
		Pin No.	Port	Alternate Function	Pin No.	Port	Alternate Function
I <sup>2</sup> C00	SDA00	35	P38	TXDA2/SIB2	–	–	–
	SCL00	36	P39	RXDA2/SCKB2	–	–	–
I <sup>2</sup> C01	SDA01	22	P40	SIB0	–	–	–
	SCL01	23	P41	SOB0	–	–	–
I <sup>2</sup> C02	SDA02	61	P90	A0/KR6/TXDA1	–	–	–
	SCL02	62	P91	A1/KR7/RXDA1/KR7	–	–	–
I <sup>2</sup> C03	SDA03	57	P614	TECR8	–	–	–
	SCL03	58	P615	–	–	–	–
I <sup>2</sup> C04 <sup>Note</sup>	SDA04 <sup>Note</sup>	6	P00	TIP61/TOP61	–	–	–
	SCL04 <sup>Note</sup>	7	P01	TIP60/TOP60	–	–	–
I <sup>2</sup> C05 <sup>Note</sup>	SDA05 <sup>Note</sup>	50	P67	SOB5/RXDA5	–	–	–
	SCL05 <sup>Note</sup>	51	P68	SCKB5/TXDA5	–	–	–

&lt;R&gt;

&lt;R&gt;

&lt;R&gt;

&lt;R&gt;

&lt;R&gt;

**Note** Not available in the  $\mu$ PD70F3931, 70F3932, and 70F3933

(1) I<sup>2</sup>C00

The serial transmission/reception data and serial clock pins (SDA00 and SCL00) of I<sup>2</sup>C00 are assigned to P38 and P39, respectively. When using I<sup>2</sup>C00, specify P38 and P39 as the SDA00 and SCL00 pins in advance, using the PMC3, PFC3, and PFCE3 registers.

The SDA00 and SCL00 pins and TXDA2 and RXDA2 (transmission/reception pins) of UARTA2 are alternate functions of the same pin, and therefore cannot be used simultaneously. In addition, the SDA00 and SCL00 pins and SIB2 and SCKB2 (serial reception data and serial clock pins) of CSIB2 are alternate functions of the same pin, so use the SIB2 and SCKB2 pins assigned to other port pins (P53 and P55) when using the pins simultaneously.

**(2) I<sup>2</sup>C01**

The serial transmission/reception data and serial clock pins (SDA01 and SCL01) of I<sup>2</sup>C01 are assigned to P40 and P41, respectively. When using I<sup>2</sup>C01, specify P40 and P41 as the SDA01 and SCL01 pins in advance, using the PMC4 and PFC4 registers.

The SDA01 and SCL01 pins and the transmission/reception pins (SIB0 and SOB0) of CSIB0 are alternate functions of the same pin, and therefore cannot be used simultaneously.

**(3) I<sup>2</sup>C02**

The serial transmission/reception data and serial clock pins (SDA02 and SCL02) of I<sup>2</sup>C02 are assigned to P90 and P91, respectively. When using I<sup>2</sup>C02, specify P90 and P91 as the SDA02 and SCL02 pins in advance, using the PMC9, PFC9, and PFCE9 registers.

The SDA02 and SCL02 pins and the transmission/reception pins (TXDA1 and RXDA2) of UARTA1 are alternate functions of the same pin, and therefore cannot be used simultaneously.

**(4) I<sup>2</sup>C03**

The serial transmission/reception data and serial clock pins (SDA03 and SCL03) of I<sup>2</sup>C03 are assigned to P614 and P615, respectively. When using I<sup>2</sup>C03, specify P614 and P615 as the SDA03 and SCL03 pins in advance, using the PMC6, PFC6, and PFCE6 registers.

The SDA03 pin and the encoder clear input pin (TECR8) of TMP8 are alternate functions of the same pin, and therefore cannot be used simultaneously.

**<R> (5) I<sup>2</sup>C04 (Other than  $\mu$ PD70F3931, 70F3932, and 70F3933)**

The serial transmission/reception data and serial clock pins (SDA04 and SCL04) of I<sup>2</sup>C04 are assigned to P00 and P01, respectively. When using I<sup>2</sup>C04, specify P00 and P01 as the SDA04 and SCL04 pins in advance, using the PMC0, PFC0, and PFCE0 registers.

The SDA04 and SCL04 pins and I/O pins (TIP61/TOP60 and TIP60/TOP60) of TMP6 are alternate functions of the same pin, and therefore cannot be used simultaneously.

**<R> (6) I<sup>2</sup>C05 (Other than  $\mu$ PD70F3931, 70F3932, and 70F3933)**

The serial transmission/reception data and serial clock pins (SDA05 and SCL05) of I<sup>2</sup>C05 are assigned to P67 and P68, respectively. When using I<sup>2</sup>C05, specify P67 and P68 as the SDA05 and SCL05 pins in advance, using the PMC6, PFC6, and PFCE6 registers.

The SDA05 and SCL05 pins, the serial transmission data and serial clock pins (SOB5 and  $\overline{\text{SCKB5}}$ ) of CSIB5, and transmission/reception pins (RXDA5 and TXDA5) of UARTA5 are alternate functions of the same pin, and therefore cannot be used simultaneously.

**Caution Do not switch port settings during operation. Also, be sure to disable operation of unused units for which port settings are not made.**

## 19.1.2 For V850E/SK3-H

Table 19-3. Pin Configuration

Mode	Pin Name	Alternate-Function Pin					
		Port <1>			Port <2>		
		Pin No.	Port	Alternate Function	Pin No.	Port	Alternate Function
I <sup>2</sup> C00	SDA00	40	P38	TXDA2/SIB2	–	–	–
	SCL00	41	P39	RXDA2/SCKB2	–	–	–
I <sup>2</sup> C01	SDA01	24	P40	SIB0	–	–	–
	SCL01	25	P41	SOB0	–	–	–
I <sup>2</sup> C02	SDA02	77	P90	A0/KR6/TXDA1	–	–	–
	SCL02	78	P91	A1/KR7/RXDA1/KR7	–	–	–
I <sup>2</sup> C03	SDA03	67	P614	TECR8	–	–	–
	SCL03	68	P615	–	–	–	–
I <sup>2</sup> C04	SDA04	6	P00	TIP61/TOP61	8	P20	–
	SCL04	7	P01	TIP60/TOP60	9	P21	–
I <sup>2</sup> C05	SDA05	60	P67	SOB5/RXDA5	73	P82	–
	SCL05	61	P68	SCKB5/TXDA5	74	P83	–

**(1) I<sup>2</sup>C00**

The serial transmission/reception data and serial clock pins (SDA00 and SCL00) of I<sup>2</sup>C00 are assigned to P38 and P39, respectively. When using I<sup>2</sup>C00, specify P38 and P39 as the SDA00 and SCL00 pins in advance, using the PMC3, PFC3, and PFCE3 registers.

The SDA00 and SCL00 pins and the transmission/reception pins (TXDA2 and RXDA2) of UARTA2 are alternate functions of the same pin. Use the TXDA2 and RXDA2 pins assigned to other port pins (P311 and P312) when using the pins simultaneously. In addition, the SDA00 and SCL00 pins and SIB2 and SCKB2 (serial reception data and serial clock pins) of CSIB2 are alternate functions of the same pin, so use the SIB2 and SCKB2 pins assigned to other port pins (P53 and P55) when using the pins simultaneously.

**(2) I<sup>2</sup>C01**

The serial transmission/reception data and serial clock pins (SDA01 and SCL01) of I<sup>2</sup>C01 are assigned to P40 and P41, respectively. When using I<sup>2</sup>C01, specify P40 and P41 as the SDA01 and SCL01 pins in advance, using the PMC4 and PFC4 registers.

The SDA01 and SCL01 pins and SIB0 and SOB0 (transmission/reception pins) of CSIB0 are alternate functions of the same pin, and therefore cannot be used simultaneously.

**(3) I<sup>2</sup>C02**

The serial transmission/reception data and serial clock pins (SDA02 and SCL02) of I<sup>2</sup>C02 are assigned to P90 and P91, respectively. When using I<sup>2</sup>C02, specify P90 and P91 as the SDA02 and SCL02 pins in advance, using the PMC9, PFC9, and PFCE9 registers.

The SDA02 and SCL02 pins and the transmission/reception pins (TXDA1 and RXDA1) of UARTA1 are alternate functions of the same pin, so use the TXDA1 and RXDA1 pins assigned to other port pins (P151 and P150) when using the pins simultaneously.

**(4) I<sup>2</sup>C03**

The serial transmission/reception data and serial clock pins (SDA03 and SCL03) of I<sup>2</sup>C03 are assigned to P614 and P615, respectively. When using I<sup>2</sup>C03, specify P614 and P615 as the SDA03 and SCL03 pins in advance, using the PMC6, PFC6, and PFCE6 registers.

The SDA03 pin and the encoder clear input pin (TECR8) of TMP8 are alternate functions of the same pin, and therefore cannot be used simultaneously.

**(5) I<sup>2</sup>C04**

The serial transmission/reception data and serial clock pins (SDA04 and SCL04) of I<sup>2</sup>C04 are assigned to two port pins P00, P01 and P20, P21, respectively, and can be used at either one of the two port pins only. When using I<sup>2</sup>C04 at P00 and P01, specify P00 and P01 as the SDA04 and SCL04 pins in advance, using the PMC0, PFC0, and PFCE0 registers. When using I<sup>2</sup>C04 at P20 and P21, specify P20 and P21 as the SDA04 and SCL04 pins in advance, using the PMC2 register.

P00 and P01 function as the I/O pins (TIP61/TOP61 and TIP60/TOP60) of TMP6. By using I<sup>2</sup>C04 at P20 and P21, these alternate functions can be used simultaneously with I<sup>2</sup>C04.

**(6) I<sup>2</sup>C05**

The serial transmission/reception data and serial clock pins (SDA05 and SCL05) of I<sup>2</sup>C05 are assigned to two port pins P67, P68 and P82, P83, respectively, and can be used at either one of the two port pins only. When using I<sup>2</sup>C05 at P67 and P68, specify P67 and P68 as the SDA05 and SCL05 pins in advance, using the PMC6, PFC6, and PFCE6 registers. When using I<sup>2</sup>C05 at P82 and P83, specify P82 and P83 as the SDA05 and SCL05 pins in advance, using the PMC8 register.

P67 and P68 function as the serial transmission data and serial clock pins (SOB5 and  $\overline{\text{SCKB5}}$ ) of CSIB5 and transmission/reception pins (RXDA5 and TXDA5) of UARTA5. By using I<sup>2</sup>C05 at P82 and P83, these alternate functions can be used simultaneously with I<sup>2</sup>C05.

**Caution** Do not switch port settings during operation. Also, be sure to disable operation of unused units for which port settings are not made.

## 19.2 Features

I<sup>2</sup>C0n has the following two modes.

- Operation stopped mode
- I<sup>2</sup>C (Inter IC) bus mode (multimasters supported)

### (1) Operation stopped mode

In this mode, serial transfers are not performed, thus enabling a reduction in power consumption.

### (2) I<sup>2</sup>C bus mode (multimaster support)

This mode is used for 8-bit data transfers with several devices via two lines: a serial clock pin (SCL0n) and a serial data bus pin (SDA0n).

This mode complies with the I<sup>2</sup>C bus format and the master device can generate “start condition”, “address”, “transfer direction specification”, “data”, and “stop condition” data to the slave device via the serial data bus. The slave device automatically detects the received statuses and data by hardware. This function can simplify the part of an application program that controls the I<sup>2</sup>C bus.

Since SCL0n and SDA0n pins are used for N-ch open-drain outputs, I<sup>2</sup>C0n requires pull-up resistors for the serial clock line and the serial data bus line.

<R> **Remark** Only  $\mu$ PD70F3931 (V850E/SJ3-H), 70F3932 (V850E/SJ3-H), and 70F3933 (V850E/SJ3-H):  
 n = 0 to 3  
 Other than  $\mu$ PD70F3931 (V850E/SJ3-H), 70F3932 (V850E/SJ3-H), and 70F3933 (V850E/SJ3-H):  
 n = 0 to 5

19.3 Configuration

The block diagram of the I<sup>2</sup>C0n is shown below.

Figure 19-1. Block Diagram of I<sup>2</sup>C0n (1/2)

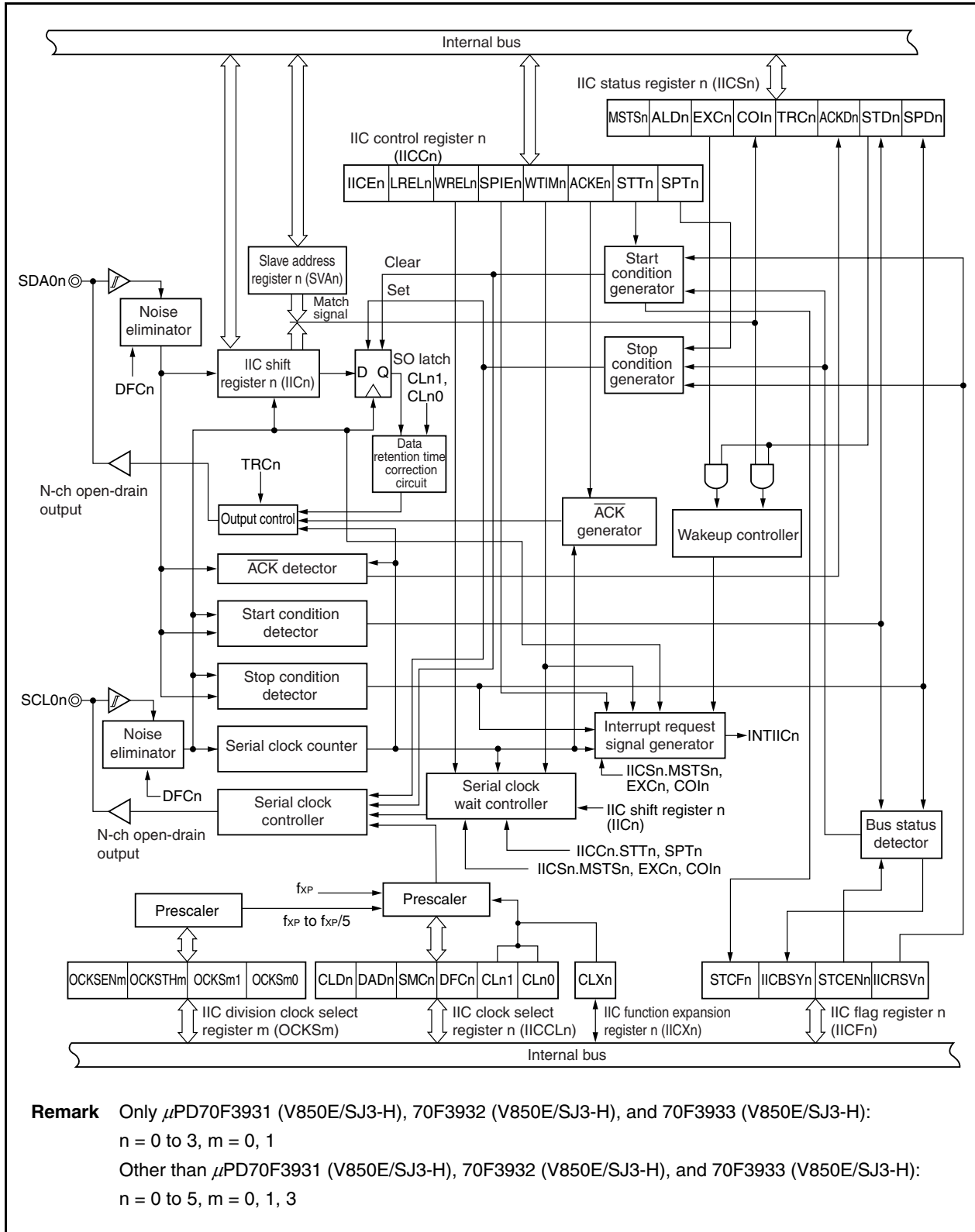

<R> **Remark** Only  $\mu$ PD70F3931 (V850E/SJ3-H), 70F3932 (V850E/SJ3-H), and 70F3933 (V850E/SJ3-H):  
 n = 0 to 3, m = 0, 1  
 Other than  $\mu$ PD70F3931 (V850E/SJ3-H), 70F3932 (V850E/SJ3-H), and 70F3933 (V850E/SJ3-H):  
 n = 0 to 5, m = 0, 1, 3

Figure 19-1. Block Diagram of I<sup>2</sup>C0n (2/2)

**Remarks 2.**  $f_{XP}$ : Peripheral clock frequency (prescaler 1 input clock frequency)  
 In clock mode 1,  $f_{XP} = f_{XX}$   
 In clock mode 2,  $f_{XP} = f_{XMPLL}/2$  (14.64 to 16 MHz)  
 In clock mode 3,  $f_{XP} = f_{XMPLL}$  (29.28 to 32 MHz)  
 In clock mode 4,  $f_{XP} = f_{XMPLL}/2$  (20.88 to 24 MHz)  
 $f_{XX}$ : Main clock frequency  
 $f_{XMPLL}$ : PLL output clock frequency for peripheral clock

A serial bus configuration example is shown below.

Figure 19-2. Serial Bus Configuration Example Using I<sup>2</sup>C Bus

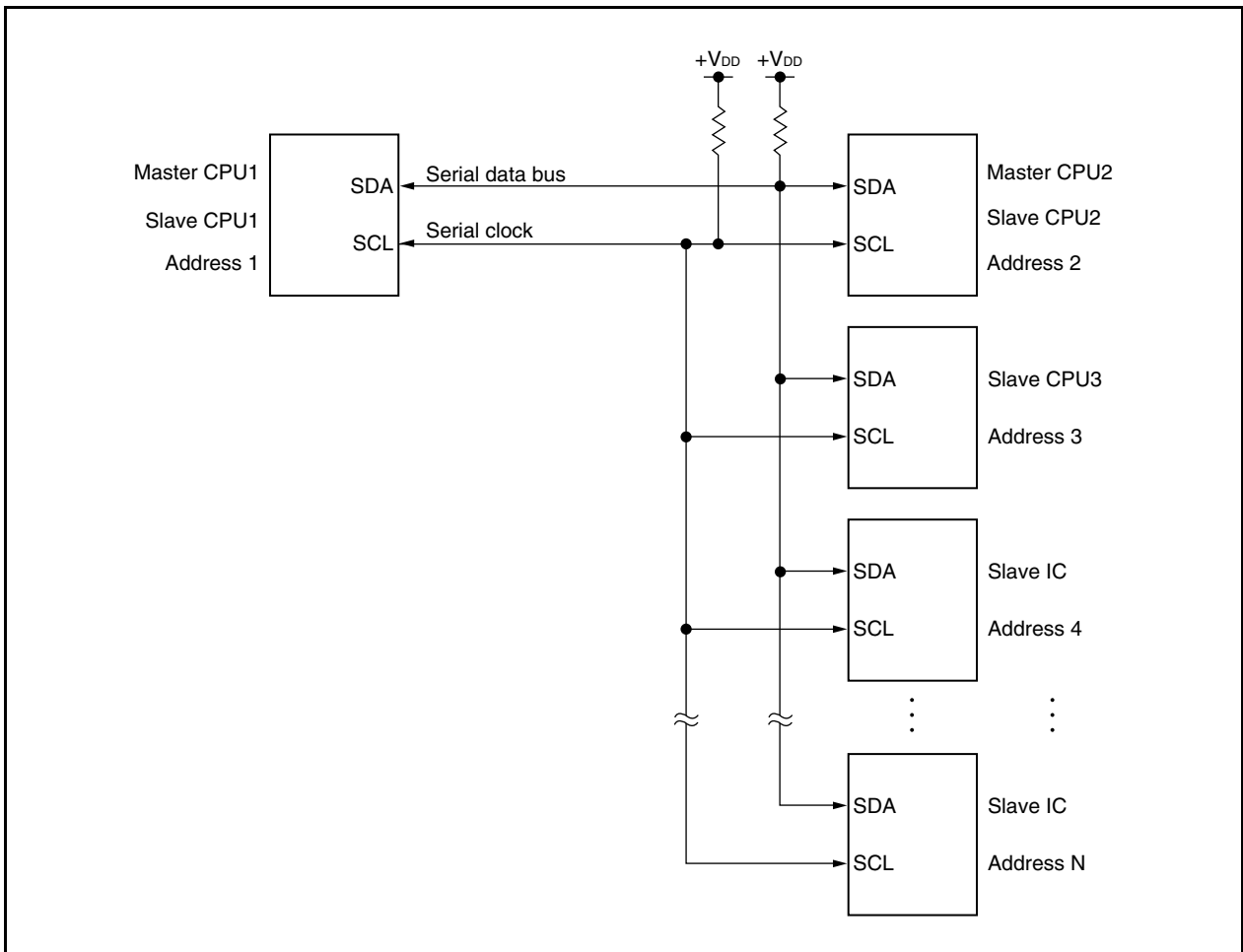

I<sup>2</sup>C0n includes the following hardware.

**Table 19-4. Configuration of I<sup>2</sup>C0n**

Item	Configuration
Registers	IIC shift register n (IICn) Slave address register n (SVAn)
Control registers	IIC control register n (IICn) IIC status register n (IICSn) IIC flag register n (IICFn) IIC clock select register n (IICCLn) IIC function expansion register n (IICXn) IIC division clock select registers 0, 1 (OCKS0, OCKS1)

**(1) IIC shift register n (IICn)**

The IICn register converts 8-bit serial data into 8-bit parallel data and vice versa, and can be used for both transmission and reception.

Write and read operations to the IICn register are used to control the actual transmit and receive operations.

This register can be read or written in 8-bit units.

Reset sets this register to 00H.

**(2) Slave address register n (SVAn)**

The SVAn register sets local addresses when in slave mode.

This register can be read or written in 8-bit units.

Reset sets this register to 00H.

**(3) SO latch**

The SO latch is used to retain the output level of the SDA0n pin.

**(4) Wakeup controller**

This circuit generates an interrupt request signal (INTIICn) when the address received by this register matches the address value set to the SVAn register or when an extension code is received.

**(5) Prescaler**

This selects the sampling clock to be used.

**(6) Serial clock counter**

This counter counts the serial clocks that are output and the serial clocks that are input during transmit/receive operations and is used to verify that 8-bit data was transmitted or received.

<R> **Remark** Only  $\mu$ PD70F3931 (V850E/SJ3-H), 70F3932 (V850E/SJ3-H), and 70F3933 (V850E/SJ3-H):  
n = 0 to 3  
Other than  $\mu$ PD70F3931 (V850E/SJ3-H), 70F3932 (V850E/SJ3-H), and 70F3933 (V850E/SJ3-H):  
n = 0 to 5



**(7) Interrupt request signal generator**

This circuit controls the generation of interrupt request signals (INTIICn).

An I<sup>2</sup>C interrupt is generated following either of two triggers.

- Falling edge of eighth or ninth clock of the serial clock (set by IICn.WTIMn bit)
- Interrupt occurrence due to stop condition detection (set by IICn.SPIEn bit)

**(8) Serial clock controller**

In master mode, this circuit generates the clock output via the SCL0n pin from the sampling clock.

**(9) Serial clock wait controller**

This circuit controls the wait timing.

**(10)  $\overline{\text{ACK}}$  generator, stop condition detector, start condition detector, and  $\overline{\text{ACK}}$  detector**

These circuits are used to generate and detect various statuses.

**(11) Data hold time correction circuit**

This circuit generates the hold time for data corresponding to the falling edge of the SCL0n pin.

**(12) Start condition generator**

A start condition is generated when the IICn.STTn bit is set.

However, in the communication reservation disabled status (IICFn.IICRSVn bit = 1), this request is ignored and the IICFn.STCFn bit is set to 1 if the bus is not released (IICFn.IICBSYn bit = 1).

**(13) Stop condition generator**

A stop condition is generated when the IICn.SPTn bit is set (1).

**(14) Bus status detector**

Whether the bus is released or not is ascertained by detecting a start condition and stop condition.

However, the bus status cannot be detected immediately after operation, so set the bus status detector to the initial status by using the IICFn.STCENn bit.

<R> **Remark** Only  $\mu$ PD70F3931 (V850E/SJ3-H), 70F3932 (V850E/SJ3-H), and 70F3933 (V850E/SJ3-H):  
 n = 0 to 3  
 Other than  $\mu$ PD70F3931 (V850E/SJ3-H), 70F3932 (V850E/SJ3-H), and 70F3933 (V850E/SJ3-H):  
 n = 0 to 5

## 19.4 Registers

I<sup>2</sup>C0n is controlled by the following registers.

- IIC control register n (IICCN)
- IIC status register n (IICSn)
- IIC flag register n (IICFn)
- IIC clock select register n (IICCLn)
- IIC function expansion register n (IICXn)
- IIC division clock select register m (OCKSm)

The following registers are also used.

- IIC shift register n (IICn)
- Slave address register n (SVAn)

**Remarks 1.** For the alternate-function pin settings, see **Table 4-25 Using Port Pin as Alternate-Function Pin.**

- <R> **2.** Only  $\mu$ PD70F3931 (V850E/SJ3-H), 70F3932 (V850E/SJ3-H), and 70F3933 (V850E/SJ3-H):  
 n = 0 to 3, m = 0, 1  
 Other than  $\mu$ PD70F3931 (V850E/SJ3-H), 70F3932 (V850E/SJ3-H), and 70F3933 (V850E/SJ3-H):  
 n = 0 to 5, m = 0, 1, 3

### (1) IIC control register n (IICCN)

The IICCN registers enable/stop I<sup>2</sup>C0n operations, set the wait timing, and set other I<sup>2</sup>C operations.

These registers can be read or written in 8-bit or 1-bit units. However, set the SPIEn, WTIMn, and ACKEn bits when the IICEn bit is 0 or during the wait period. When setting the IICEn bit from “0” to “1”, these bits can also be set at the same time.

Reset sets these registers to 00H.

<R>

After reset: 00H      R/W      Address: IICC0 FFFFFFFD82H, IICC1 FFFFFFFD92H, IICC2 FFFFFFFDA2H, IICC3, FFFFFFFDB2H, IICC4 FFFFFFFDC2H<sup>Note 1</sup>, IICC5 FFFFFFFDD2H<sup>Note 1</sup>

	<7>	<6>	<5>	<4>	<3>	<2>	<1>	<0>
IICcn	IICEn	LRELn	WRELn	SPIEn	WTIMn	ACKEn	STTn	SPTn

IICEn	Specification of I <sup>2</sup> Cn operation enable/disable
0	Operation stopped. IICSn register reset <sup>Note 2</sup> . Internal operation stopped.
1	Operation enabled.
Be sure to set this bit to 1 when the SCL0n and SDA0n lines are high level.	
Condition for clearing (IICEn bit = 0)	
<ul style="list-style-type: none"> <li>• Cleared by instruction</li> <li>• After reset</li> </ul>	Condition for setting (IICEn bit = 1)
	<ul style="list-style-type: none"> <li>• Set by instruction</li> </ul>

LRELn <sup>Note 3</sup>	Exit from communications
0	Normal operation
1	This exits from the current communication operation and sets standby mode. This setting is automatically cleared after being executed. Its uses include cases in which a locally irrelevant extension code has been received. The SCL0n and SDA0n lines are set to high impedance. The STTn and SPTn bits and the MSTSn, EXCn, COIn, TRCn, ACKDn, and STDn bits of the IICSn register are cleared.
The standby mode following exit from communications remains in effect until the following communication entry conditions are met.	
<ul style="list-style-type: none"> <li>• After a stop condition is detected, restart is in master mode.</li> <li>• An address match occurs or an extension code is received after the start condition.</li> </ul>	
Condition for clearing (LRELn bit = 0)	
<ul style="list-style-type: none"> <li>• Automatically cleared after execution</li> <li>• After reset</li> </ul>	Condition for setting (LRELn bit = 1)
	<ul style="list-style-type: none"> <li>• Set by instruction</li> </ul>

WRELn <sup>Note 3</sup>	Wait state cancellation control
0	Wait state not canceled
1	Wait state canceled. This setting is automatically cleared after wait state is canceled.
Condition for clearing (WRELn bit = 0)	
<ul style="list-style-type: none"> <li>• Automatically cleared after execution</li> <li>• After reset</li> </ul>	Condition for setting (WRELn bit = 1)
	<ul style="list-style-type: none"> <li>• Set by instruction</li> </ul>

<R>

- Notes**
1. Not available in the  $\mu$ PD70F3931 (V850E/SJ3-H), 70F3932 (V850E/SJ3-H), and 70F3933 (V850E/SJ3-H)
  2. The IICSn register, IICFn.STCFn and IICFn.IICBSYn bits, and IICCLn.CLDn and IICCLn.DADn bits are reset.
  3. This flag's signal is invalid when the IICEn bit = 0.

**Caution** If the I<sup>2</sup>Cn operation is enabled (IICEn bit = 1) when the SCL0n line is high level and the SDA0n line is low level, the start condition is detected immediately. To avoid this, after enabling the I<sup>2</sup>Cn operation, immediately set the LRELn bit to 1 with a bit manipulation instruction.

<R>

- Remarks**
1. The LRELn and WRELn bits are 0 when read after the data has been set.
  2. Only  $\mu$ PD70F3931 (V850E/SJ3-H), 70F3932 (V850E/SJ3-H), and 70F3933 (V850E/SJ3-H):  
n = 0 to 3  
Other than  $\mu$ PD70F3931 (V850E/SJ3-H), 70F3932 (V850E/SJ3-H), and 70F3933 (V850E/SJ3-H): n = 0 to 5

SPIEn <sup>Note</sup>	Enable/disable generation of interrupt request when stop condition is detected	
0	Disabled	
1	Enabled	
Condition for clearing (SPIEn bit = 0)		Condition for setting (SPIEn bit = 1)
<ul style="list-style-type: none"> <li>• Cleared by instruction</li> <li>• After reset</li> </ul>		<ul style="list-style-type: none"> <li>• Set by instruction</li> </ul>

WTIMn <sup>Note</sup>	Control of wait state and interrupt request generation	
0	Interrupt request is generated at the eighth clock's falling edge. Master mode: After output of eight clocks, clock output is set to low level and the wait state is set. Slave mode: After input of eight clocks, the clock is set to low level and the wait state is set for the master device.	
1	Interrupt request is generated at the ninth clock's falling edge. Master mode: After output of nine clocks, clock output is set to low level and the wait state is set. Slave mode: After input of nine clocks, the clock is set to low level and the wait state is set for the master device.	
During address transfer, an interrupt occurs at the falling edge of the ninth clock regardless of this bit setting. This bit setting becomes valid when the address transfer is completed. In master mode, a wait state is inserted at the falling edge of the ninth clock during address transfer. For a slave device that has received a local address, a wait state is inserted at the falling edge of the ninth clock after $\overline{\text{ACK}}$ is generated. When the slave device has received an extension code, however, a wait state is inserted at the falling edge of the eighth clock.		
Condition for clearing (WTIMn bit = 0)		Condition for setting (WTIMn bit = 1)
<ul style="list-style-type: none"> <li>• Cleared by instruction</li> <li>• After reset</li> </ul>		<ul style="list-style-type: none"> <li>• Set by instruction</li> </ul>

ACKEn <sup>Note</sup>	Acknowledgment control	
0	Acknowledgment disabled.	
1	Acknowledgment enabled. During the ninth clock period, the SDA0n line is set to low level.	
The ACKEn bit setting is invalid for address reception. In this case, $\overline{\text{ACK}}$ is generated when the addresses match. However, the ACKEn bit setting is valid for reception of the extension code.		
Condition for clearing (ACKEn bit = 0)		Condition for setting (ACKEn bit = 1)
<ul style="list-style-type: none"> <li>• Cleared by instruction</li> <li>• After reset</li> </ul>		<ul style="list-style-type: none"> <li>• Set by instruction</li> </ul>

**Note** This flag's signal is invalid when the IICEn bit = 0.

**Remark** Only  $\mu$ PD70F3931 (V850E/SJ3-H), 70F3932 (V850E/SJ3-H), and 70F3933 (V850E/SJ3-H):  
 n = 0 to 3  
 Other than  $\mu$ PD70F3931 (V850E/SJ3-H), 70F3932 (V850E/SJ3-H), and 70F3933 (V850E/SJ3-H): n = 0 to 5

<R>

STTn	Start condition trigger				
0	Start condition is not generated.				
1	<p>When bus is released (in STOP mode):                      A start condition is generated (for starting as master). The SDA0n line is changed from high level to low level while the SCLn line is high level and then the start condition is generated. Next, after the rated amount of time has elapsed, the SCL0n line is changed to low level (wait state).</p> <p>During communication with a third party:</p> <ul style="list-style-type: none"> <li>• If the communication reservation function is enabled (IICFn.IICRSVn bit = 0)                              This trigger functions as a start condition reserve flag. When set to 1, it releases the bus and then automatically generates a start condition.</li> <li>• If the communication reservation function is disabled (IICRSVn = 1)                              The IICFn.STCFn bit is set to 1 to clear the information set (1) to the STTn bit. This trigger does not generate a start condition.</li> </ul> <p>In the wait state (when master device):                      A restart condition is generated after the wait state is released.</p>				
<p>Cautions concerning set timing</p> <p>For master reception: Cannot be set to 1 during transfer. Can be set to 1 only when the ACKEn bit has been set to 0 and the slave has been notified of final reception. <u>        </u></p> <p>For master transmission: A start condition cannot be generated normally during the ACK period. Set to 1 during the wait period that follows output of the ninth clock.</p> <p>For slave: Even when the communication reservation function is disabled (IICRSVn bit = 1), the communication reservation status is entered.</p> <ul style="list-style-type: none"> <li>• Setting to 1 at the same time as the SPTn bit is prohibited.</li> <li>• When the STTn bit is set to 1, setting the STTn bit to 1 again is disabled until the setting is cleared to 0.</li> </ul>					
<table border="1"> <thead> <tr> <th>Condition for clearing (STTn bit = 0)</th> <th>Condition for setting (STTn bit = 1)</th> </tr> </thead> <tbody> <tr> <td> <ul style="list-style-type: none"> <li>• When the STTn bit is set to 1 in the communication reservation disabled status</li> <li>• Cleared by loss in arbitration</li> <li>• Cleared by start condition generation in the master device</li> <li>• When the LRELn bit = 1 (communication save)</li> <li>• When the IICEn bit = 0 (operation stop)</li> <li>• After reset</li> </ul> </td> <td> <ul style="list-style-type: none"> <li>• Set by instruction</li> </ul> </td> </tr> </tbody> </table>		Condition for clearing (STTn bit = 0)	Condition for setting (STTn bit = 1)	<ul style="list-style-type: none"> <li>• When the STTn bit is set to 1 in the communication reservation disabled status</li> <li>• Cleared by loss in arbitration</li> <li>• Cleared by start condition generation in the master device</li> <li>• When the LRELn bit = 1 (communication save)</li> <li>• When the IICEn bit = 0 (operation stop)</li> <li>• After reset</li> </ul>	<ul style="list-style-type: none"> <li>• Set by instruction</li> </ul>
Condition for clearing (STTn bit = 0)	Condition for setting (STTn bit = 1)				
<ul style="list-style-type: none"> <li>• When the STTn bit is set to 1 in the communication reservation disabled status</li> <li>• Cleared by loss in arbitration</li> <li>• Cleared by start condition generation in the master device</li> <li>• When the LRELn bit = 1 (communication save)</li> <li>• When the IICEn bit = 0 (operation stop)</li> <li>• After reset</li> </ul>	<ul style="list-style-type: none"> <li>• Set by instruction</li> </ul>				

- Remarks**
1. The STTn bit is 0 if it is read immediately after data setting.
  2. Only  $\mu$ PD70F3931 (V850E/SJ3-H), 70F3932 (V850E/SJ3-H), and 70F3933 (V850E/SJ3-H):  
 n = 0 to 3  
 Other than  $\mu$ PD70F3931 (V850E/SJ3-H), 70F3932 (V850E/SJ3-H), and 70F3933 (V850E/SJ3-H): n = 0 to 5

<R>

SPTn	Stop condition trigger				
0	Stop condition is not generated.				
1	Stop condition is generated (termination of master device's transfer). After the SDA0n line goes to low level, either set the SCL0n line to high level or wait until the SCL0n pin goes to high level. Next, after the rated amount of time has elapsed, the SDA0n line is changed from low level to high level and a stop condition is generated.				
<p>Cautions concerning set timing</p> <p>For master reception: Cannot be set to 1 during transfer. Can be set to 1 only when the ACKEn bit has been set to 0 and during the wait period after the slave has been notified of final reception.</p> <p>For master transmission: A stop condition cannot be generated normally during the <math>\overline{\text{ACK}}</math> reception period. Set to 1 during the wait period that follows output of the ninth clock.</p> <ul style="list-style-type: none"> <li>• Cannot be set to 1 at the same time as the STTn bit.</li> <li>• The SPTn bit can be set to 1 only when in master mode<sup>Note</sup>.</li> <li>• When the WTIMn bit has been set to 0, if the SPTn bit is set to 1 during the wait period that follows output of eight clocks, note that a stop condition will be generated during the high-level period of the ninth clock. The WTIMn bit should be changed from 0 to 1 during the wait period following output of eight clocks, and the SPTn bit should be set to 1 during the wait period that follows output of the ninth clock.</li> <li>• When the SPTn bit is set to 1, setting the SPTn bit to 1 again is disabled until the setting is cleared to 0.</li> </ul>					
<table border="1"> <thead> <tr> <th>Condition for clearing (SPTn bit = 0)</th> <th>Condition for setting (SPTn bit = 1)</th> </tr> </thead> <tbody> <tr> <td> <ul style="list-style-type: none"> <li>• Cleared by loss in arbitration</li> <li>• Automatically cleared after stop condition is detected</li> <li>• When the LRELn bit = 1 (communication save)</li> <li>• When the IICEn bit = 0 (operation stop)</li> <li>• After reset</li> </ul> </td> <td> <ul style="list-style-type: none"> <li>• Set by instruction</li> </ul> </td> </tr> </tbody> </table>		Condition for clearing (SPTn bit = 0)	Condition for setting (SPTn bit = 1)	<ul style="list-style-type: none"> <li>• Cleared by loss in arbitration</li> <li>• Automatically cleared after stop condition is detected</li> <li>• When the LRELn bit = 1 (communication save)</li> <li>• When the IICEn bit = 0 (operation stop)</li> <li>• After reset</li> </ul>	<ul style="list-style-type: none"> <li>• Set by instruction</li> </ul>
Condition for clearing (SPTn bit = 0)	Condition for setting (SPTn bit = 1)				
<ul style="list-style-type: none"> <li>• Cleared by loss in arbitration</li> <li>• Automatically cleared after stop condition is detected</li> <li>• When the LRELn bit = 1 (communication save)</li> <li>• When the IICEn bit = 0 (operation stop)</li> <li>• After reset</li> </ul>	<ul style="list-style-type: none"> <li>• Set by instruction</li> </ul>				

**Note** Set the SPTn bit to 1 only in master mode. However, when the IICRSVn bit is 0, the SPTn bit must be set to 1 and a stop condition generated before the first stop condition is detected following the switch to the operation enabled status. For details, see **19.15 Cautions**.

**Caution** When the TRCn bit = 1, the WRELn bit is set to 1 during the ninth clock and the wait state is canceled, after which the TRCn bit is cleared to 0 and the SDA0n line is set to high impedance.

**Remarks**

1. The SPTn bit is 0 if it is read immediately after data setting.
2. Only  $\mu$ PD70F3931 (V850E/SJ3-H), 70F3932 (V850E/SJ3-H), and 70F3933 (V850E/SJ3-H):  
n = 0 to 3  
Other than  $\mu$ PD70F3931 (V850E/SJ3-H), 70F3932 (V850E/SJ3-H), and 70F3933 (V850E/SJ3-H): n = 0 to 5

<R>

**(2) IIC status registers n (IICSn)**

The IICSn registers indicate the status of the I<sup>2</sup>C0n bus.

These registers are read-only, in 8-bit or 1-bit units. However, the IICSn register can only be read when the IICn.STTn bit is 1 or during the wait period.

Reset sets these registers to 00H.

**Caution** Accessing the IICSn register is prohibited in the following statuses. For details, refer to 3.4.9

**(2) Accessing specific on-chip peripheral I/O registers.**

- When the CPU operates with the subclock and the main clock oscillation is stopped
- When the CPU operates with the internal oscillation clock

(1/3)

<R>

After reset: 00H      R      Address: IICS0 FFFF86H, IICS1 FFFF96H, IICS2 FFFFDA6H,  
IICS3 FFFFDB6H, IICS4 FFFFDC6H<sup>Note 1</sup>, IICS5 FFFFDD6H<sup>Note 1</sup>

	<7>	<6>	<5>	<4>	<3>	<2>	<1>	<0>
IICSn	MSTS <sub>n</sub>	ALD <sub>n</sub>	EXC <sub>n</sub>	COI <sub>n</sub>	TRC <sub>n</sub>	ACKD <sub>n</sub>	STD <sub>n</sub>	SPD <sub>n</sub>

MSTS <sub>n</sub>	Master device status	
0	Slave device status or communication standby status	
1	Master device communication status	
Condition for clearing (MSTS <sub>n</sub> bit = 0)		Condition for setting (MSTS <sub>n</sub> bit = 1)
<ul style="list-style-type: none"> <li>• When a stop condition is detected</li> <li>• When the ALD<sub>n</sub> bit = 1 (arbitration loss)</li> <li>• Cleared by LREL<sub>n</sub> bit = 1 (communication save)</li> <li>• When the IICEn bit changes from 1 to 0 (operation stop)</li> <li>• After reset</li> </ul>		<ul style="list-style-type: none"> <li>• When a start condition is generated</li> </ul>

ALD <sub>n</sub>	Arbitration loss detection	
0	This status means either that there was no arbitration or that the arbitration result was a “win”.	
1	This status indicates the arbitration result was a “loss”. The MSTS <sub>n</sub> bit is cleared to 0.	
Condition for clearing (ALD <sub>n</sub> bit = 0)		Condition for setting (ALD <sub>n</sub> bit = 1)
<ul style="list-style-type: none"> <li>• Automatically cleared after the IICS<sub>n</sub> register is read<sup>Note 2</sup></li> <li>• When the IICEn bit changes from 1 to 0 (operation stop)</li> <li>• After reset</li> </ul>		<ul style="list-style-type: none"> <li>• When the arbitration result is a “loss”.</li> </ul>

<R>

- Notes**
1. Other than the μPD70F3931 (V850E/SJ3-H), 70F3932 (V850E/SJ3-H), and 70F3933 (V850E/SJ3-H)
  2. The ALD<sub>n</sub> bit is also cleared when a bit manipulation instruction is executed for another bit in the IICS<sub>n</sub> register.

<R>

**Remark** Only μPD70F3931 (V850E/SJ3-H), 70F3932 (V850E/SJ3-H), and 70F3933 (V850E/SJ3-H):  
n = 0 to 3  
Other than μPD70F3931 (V850E/SJ3-H), 70F3932 (V850E/SJ3-H), and 70F3933 (V850E/SJ3-H): n = 0 to 5

EXCn	Detection of extension code reception	
0	Extension code was not received.	
1	Extension code was received.	
Condition for clearing (EXCn bit = 0)		Condition for setting (EXCn bit = 1)
<ul style="list-style-type: none"> <li>• When a start condition is detected</li> <li>• When a stop condition is detected</li> <li>• Cleared by LRELn bit = 1 (communication save)</li> <li>• When the IICEn bit changes from 1 to 0 (operation stop)</li> <li>• After reset</li> </ul>		<ul style="list-style-type: none"> <li>• When the higher four bits of the received address data are either "0000" or "1111" (set at the rising edge of the eighth clock).</li> </ul>

COIn	Matching address detection	
0	Addresses do not match.	
1	Addresses match.	
Condition for clearing (COIn bit = 0)		Condition for setting (COIn bit = 1)
<ul style="list-style-type: none"> <li>• When a start condition is detected</li> <li>• When a stop condition is detected</li> <li>• Cleared by LRELn bit = 1 (communication save)</li> <li>• When the IICEn bit changes from 1 to 0 (operation stop)</li> <li>• After reset</li> </ul>		<ul style="list-style-type: none"> <li>• When the received address matches the local address (SVAn register) (set at the rising edge of the eighth clock).</li> </ul>

TRCn	Transmit/receive status detection	
0	Receive status (other than transmit status). The SDA0n line is set to high impedance.	
1	Transmit status. The value in the SO latch is enabled for output to the SDA0n line (valid starting at the falling edge of the first byte's ninth clock).	
Condition for clearing (TRCn bit = 0)		Condition for setting (TRCn bit = 1)
<ul style="list-style-type: none"> <li>• When a stop condition is detected</li> <li>• Cleared by LRELn bit = 1 (communication save)</li> <li>• When the IICEn bit changes from 1 to 0 (operation stop)</li> <li>• Cleared by IICn.WRELn bit = 1<sup>Note</sup></li> <li>• When the ALDn bit changes from 0 to 1 (arbitration loss)</li> <li>• After reset</li> </ul> <p>Master</p> <ul style="list-style-type: none"> <li>• When "1" is output to the first byte's LSB (transfer direction specification bit)</li> </ul> <p>Slave</p> <ul style="list-style-type: none"> <li>• When a start condition is detected</li> </ul> <p>When not used for communication</p>		<p>Master</p> <ul style="list-style-type: none"> <li>• When a start condition is generated</li> <li>• When "0" is output to the first byte's LSB (transfer direction specification bit)</li> </ul> <p>Slave</p> <ul style="list-style-type: none"> <li>• When "1" is input by the first byte's LSB (transfer direction specification bit)</li> </ul>

**Note** The TRCn bit is cleared to 0 and SDA0n line becomes high impedance when the WRELn bit is set to 1 and the wait state is canceled to 0 at the ninth clock by TRCn bit = 1.

**Remark** Only  $\mu$ PD70F3931 (V850E/SJ3-H), 70F3932 (V850E/SJ3-H), and 70F3933 (V850E/SJ3-H):  
n = 0 to 3  
Other than  $\mu$ PD70F3931 (V850E/SJ3-H), 70F3932 (V850E/SJ3-H), and 70F3933 (V850E/SJ3-H): n = 0 to 5

<R>



ACKDn	$\overline{\text{ACK}}$ detection	
0	$\overline{\text{ACK}}$ was not detected.	
1	$\overline{\text{ACK}}$ was detected.	
Condition for clearing (ACKDn bit = 0)		Condition for setting (ACKDn bit = 1)
<ul style="list-style-type: none"> <li>• When a stop condition is detected</li> <li>• At the rising edge of the next byte's first clock</li> <li>• Cleared by LRELn bit = 1 (communication save)</li> <li>• When the IICEn bit changes from 1 to 0 (operation stop)</li> <li>• After reset</li> </ul>		<ul style="list-style-type: none"> <li>• After the SDA0n bit is set to low level at the rising edge of the SCL0n pin's ninth clock</li> </ul>

STDn	Start condition detection	
0	Start condition was not detected.	
1	Start condition was detected. This indicates that the address transfer period is in effect	
Condition for clearing (STDn bit = 0)		Condition for setting (STDn bit = 1)
<ul style="list-style-type: none"> <li>• When a stop condition is detected</li> <li>• At the rising edge of the next byte's first clock following address transfer</li> <li>• Cleared by LRELn bit = 1 (communication save)</li> <li>• When the IICEn bit changes from 1 to 0 (operation stop)</li> <li>• After reset</li> </ul>		<ul style="list-style-type: none"> <li>• When a start condition is detected</li> </ul>

SPDn	Stop condition detection	
0	Stop condition was not detected.	
1	Stop condition was detected. The master device's communication is terminated and the bus is released.	
Condition for clearing (SPDn bit = 0)		Condition for setting (SPDn bit = 1)
<ul style="list-style-type: none"> <li>• At the rising edge of the address transfer byte's first clock following setting of this bit and detection of a start condition</li> <li>• When the IICEn bit changes from 1 to 0 (operation stop)</li> <li>• After reset</li> </ul>		<ul style="list-style-type: none"> <li>• When a stop condition is detected</li> </ul>

<R>

**Remark** Only  $\mu$ PD70F3931 (V850E/SJ3-H), 70F3932 (V850E/SJ3-H), and 70F3933 (V850E/SJ3-H):  
 n = 0 to 3  
 Other than  $\mu$ PD70F3931 (V850E/SJ3-H), 70F3932 (V850E/SJ3-H), and 70F3933  
 (V850E/SJ3-H): n = 0 to 5

**(3) IIC flag register n (IICFn)**

The IICFn registers set the I<sup>2</sup>C0n operation mode and indicate the I<sup>2</sup>C bus status.

These registers can be read or written in 8-bit or 1-bit units. However, the STCFn and IICBSYn bits are read-only.

IICRSVn enables/disables the communication reservation function (see **19.14 Communication Reservation**).

The initial value of the IICBSYn bit is set by using the STCENn bit (see **19.15 Cautions**).

The IICRSVn and STCENn bits can be written only when operation of I<sup>2</sup>C0n is disabled (IICn.IICEn bit = 0).

After operation is enabled, IICFn can be read.

Reset sets these registers to 00H.

(1/2)

<R>

After reset: 00H R/W<sup>Note 1</sup> Address: IICF0 FFFF88AH, IICF1 FFFF89AH, IICF2 FFFF8AAH, IICF3 FFFF8BAH, IICF4 FFFF8CAH<sup>Note 2</sup>, IICF5 FFFF8DAH<sup>Note 2</sup>

	<7>	<6>	5	4	3	2	<1>	<0>
IICFn	STCFn	IICBSYn	0	0	0	0	STCENn	IICRSVn

STCFn	STTn bit clear
0	Start condition issued
1	Start condition cannot be issued, STTn bit cleared
Condition for clearing (STCFn bit = 0)	
<ul style="list-style-type: none"> <li>• Cleared by IICn.STTn bit = 1</li> <li>• When the IICn.IICEn bit = 0</li> <li>• After reset</li> </ul>	
Condition for setting (STCFn bit = 1)	
<ul style="list-style-type: none"> <li>• When start condition is not issued and STTn flag is cleared to 0 during communication reservation is disabled (IICRSVn bit = 1).</li> </ul>	

IICBSYn	I <sup>2</sup> C0n bus status
0	Bus released status (default communication status when STCENn bit = 1)
1	Bus communication status (default communication status when STCENn bit = 0)
Condition for clearing (IICBSYn bit = 0)	
<ul style="list-style-type: none"> <li>• When stop condition is detected</li> <li>• When the IICEn bit = 0</li> <li>• After reset</li> </ul>	
Condition for setting (IICBSYn bit = 1)	
<ul style="list-style-type: none"> <li>• When start condition is detected</li> <li>• By setting the IICEn bit when the STCENn bit = 0</li> </ul>	

**Notes 1.** Bits 6 and 7 are read-only bits.

**2.** Other than the  $\mu$ PD70F3931 (V850E/SJ3-H), 70F3932 (V850E/SJ3-H), and 70F3933 (V850E/SJ3-H)

- Cautions**
1. Write the STCENn bit only when operation is stopped (IICEn bit = 0).
  2. When the STCENn bit = 1, the bus released status (IICBSYn bit = 0) is recognized regardless of the actual bus status immediately after the I<sup>2</sup>Cn bus operation is enabled. Therefore, to issue the first start condition (STTn bit = 1), it is necessary to confirm that the bus has been released, so as to not disturb other communications.
  3. Write the IICRSVn bit only when operation is stopped (IICEn bit = 0).

**Remark** Only  $\mu$ PD70F3931 (V850E/SJ3-H), 70F3932 (V850E/SJ3-H), and 70F3933 (V850E/SJ3-H): n = 0 to 3  
 Other than  $\mu$ PD70F3931 (V850E/SJ3-H), 70F3932 (V850E/SJ3-H), and 70F3933 (V850E/SJ3-H): n = 0 to 5

<R>

STCENn	Initial start enable trigger	
0	Start conditions cannot be generated until a stop condition is detected following operation enable (IICEn bit = 1).	
1	Start conditions can be generated even if a stop condition is not detected following operation enable (IICEn bit = 1).	
Condition for clearing (STCENn bit = 0)		Condition for setting (STCENn bit = 1)
<ul style="list-style-type: none"> <li>• When start condition is detected</li> <li>• After reset</li> </ul>		<ul style="list-style-type: none"> <li>• Setting by instruction</li> </ul>

IICRSVn	Communication reservation function disable bit	
0	Communication reservation enabled	
1	Communication reservation disabled	
Condition for clearing (IICRSVn bit = 0)		Condition for setting (IICRSVn bit = 1)
<ul style="list-style-type: none"> <li>• Clearing by instruction</li> <li>• After reset</li> </ul>		<ul style="list-style-type: none"> <li>• Setting by instruction</li> </ul>

- Cautions**
1. Write the STCENn bit only when operation is stopped (IICEn bit = 0).
  2. When the STCENn bit = 1, the bus released status (IICBSYn bit = 0) is recognized regardless of the actual bus status immediately after the I<sup>2</sup>Cn bus operation is enabled. Therefore, to issue the first start condition (STTn bit = 1), it is necessary to confirm that the bus has been released, so as to not disturb other communications.
  3. Write the IICRSVn bit only when operation is stopped (IICEn bit = 0).

**Remark** Only  $\mu$ PD70F3931 (V850E/SJ3-H), 70F3932 (V850E/SJ3-H), and 70F3933 (V850E/SJ3-H):  
n = 0 to 3  
Other than  $\mu$ PD70F3931 (V850E/SJ3-H), 70F3932 (V850E/SJ3-H), and 70F3933 (V850E/SJ3-H): n = 0 to 5

&lt;R&gt;

**(4) IIC clock select register n (IICCLn)**

The IICCLn registers set the transfer clock for the I<sup>2</sup>C0n bus.

These registers can be read or written in 8-bit or 1-bit units. However, the CLDn and DADn bits are read-only.

Set the IICCLn register when the IICCN.IICEn bit = 0.

The SMCn, CLn1, and CLn0 bits are set by the combination of the IICXn.CLXn bit and the OCKSTHm, OCKSm1, and OCKSm0 bits of the OCKSm register (see **19.4 (6) I<sup>2</sup>C0n transfer clock setting method**).

Reset sets these registers to 00H.

<R>

After reset: 00H      R/W<sup>Note 1</sup>      Address: IICCL0 FFFFDD84H, IICCL1 FFFFDD94H, IICCL2 FFFFDDA4H,  
IICCL3 FFFFDDB4H, IICCL4 FFFFDDC4H<sup>Note 2</sup>, IICCL5 FFFFDD4H<sup>Note 2</sup>

	7	6	<5>	<4>	3	2	1	0
IICCLn	0	0	CLDn	DADn	SMCn	DFCn	CLn1	CLn0

CLDn	Detection of SCL0n pin level (valid only when IICCN.IICEn bit = 1)
0	The SCL0n pin was detected at low level.
1	The SCL0n pin was detected at high level.
Condition for clearing (CLDn bit = 0)	
<ul style="list-style-type: none"> <li>• When the SCL0n pin is at low level</li> <li>• When the IICEn bit = 0 (operation stop)</li> <li>• After reset</li> </ul>	
Condition for setting (CLDn bit = 1)	
<ul style="list-style-type: none"> <li>• When the SCL0n pin is at high level</li> </ul>	

DADn	Detection of SDA0n pin level (valid only when IICEn bit = 1)
0	The SDA0n pin was detected at low level.
1	The SDA0n pin was detected at high level.
Condition for clearing (DADn bit = 0)	
<ul style="list-style-type: none"> <li>• When the SDA0n pin is at low level</li> <li>• When the IICEn bit = 0 (operation stop)</li> <li>• After reset</li> </ul>	
Condition for setting (DADn bit = 1)	
<ul style="list-style-type: none"> <li>• When the SDA0n pin is at high level</li> </ul>	

SMCn	Operation mode switching
0	Operation in standard mode.
1	Operation in high-speed mode.

DFCn	Digital filter operation control
0	Digital filter off.
1	Digital filter on.

The digital filter can be used only in high-speed mode.  
In high-speed mode, the transfer clock does not vary regardless of the DFCn bit setting (on/off).  
The digital filter is used to eliminate noise in high-speed mode.

**Notes 1.** Bits 4 and 5 of IICCLn are read-only bits.

**2.** Other than the  $\mu$ PD70F3931 (V850E/SJ3-H), 70F3932 (V850E/SJ3-H), and 70F3933 (V850E/SJ3-H)

**Caution** Be sure to set bits 7 and 6 of IICCLn to 0.

**Remarks 1.** When the IICCN.IICEn bit = 0, 0 is read when reading the CLDn and DADn bits.

**2.** Only  $\mu$ PD70F3931 (V850E/SJ3-H), 70F3932 (V850E/SJ3-H), and 70F3933 (V850E/SJ3-H): n = 0 to 3, m = 0, 1  
Other than  $\mu$ PD70F3931 (V850E/SJ3-H), 70F3932 (V850E/SJ3-H), and 70F3933 (V850E/SJ3-H): n = 0 to 5, m = 0, 1, 3

<R>

<R>

**(5) IIC function expansion register n (IICXn)**

The IICXn registers set I<sup>2</sup>C0n function expansion (valid only in the high-speed mode).

These registers can be read or written in 8-bit or 1-bit units.

Setting of the CLXn bit is performed in combination with the SMCn, CLn1, and CLn0 bits of the IICCLn register and the OCKSTHm, OCKSm1, and OCKSm0 bits of the OCKSm register (see **19.4 (6) I<sup>2</sup>C0n transfer clock setting method**).

Set the IICXn register when the IICCn.IICEn bit = 0.

Reset sets these registers to 00H.

<R>

After reset: 00H R/W Address: IICX0 FFFFFFFD85H, IICX1 FFFFFFFD95H, IICX2 FFFFFFFDA5H,  
IICX3 FFFFFFFDB5H, IICX4 FFFFFFFDC5H<sup>Note</sup>, IICX5 FFFFFFFDD5H<sup>Note</sup>

	7	6	5	4	3	2	1	<0>
IICXn	0	0	0	0	0	0	0	CLXn

<R>

**Note** Other than the  $\mu$ PD70F3931 (V850E/SJ3-H), 70F3932 (V850E/SJ3-H), and 70F3933 (V850E/SJ3-H)

<R>

**Remark** Only  $\mu$ PD70F3931 (V850E/SJ3-H), 70F3932 (V850E/SJ3-H), and 70F3933 (V850E/SJ3-H):  
n = 0 to 3, m = 0, 1  
Other than  $\mu$ PD70F3931 (V850E/SJ3-H), 70F3932 (V850E/SJ3-H), and 70F3933 (V850E/SJ3-H):  
n = 0 to 5, m = 0, 1, 3

**(6) I<sup>2</sup>C0n transfer clock setting method**

The I<sup>2</sup>C0n transfer clock frequency (f<sub>SCL</sub>) is calculated using the following expression.

$$f_{SCL} = 1/(M \times T + t_r + t_f)$$

M = 12, 18, 24, 36, 44, 48, 54, 60, 66, 72, 86, 88, 90, 96, 132, 172, 176, 198, 220, 258, 264, 330, 344, 430 (see **Table 19-5 Clock Settings**).

T: 1/f<sub>XP</sub>

t<sub>r</sub>: SCL0n pin rise time

t<sub>f</sub>: SCL0n pin fall time

f<sub>XP</sub>: Peripheral clock frequency (prescaler 1 input clock frequency)

In clock mode 1, f<sub>XP</sub> = f<sub>XX</sub>

In clock mode 2, f<sub>XP</sub> = f<sub>XMPLL</sub>/2 (14.64 to 16 MHz)

In clock mode 3, f<sub>XP</sub> = f<sub>XMPLL</sub> (29.28 to 32 MHz)

In clock mode 4, f<sub>XP</sub> = f<sub>XMPLL</sub>/2 (20.88 to 24 MHz)

f<sub>XX</sub>: Main clock frequency

f<sub>XMPLL</sub>: PLL output clock frequency for peripheral clock

For example, the I<sup>2</sup>C0n transfer clock frequency (f<sub>SCL</sub>) when f<sub>XP</sub> = 19.2 MHz, M = 198, t<sub>r</sub> = 200 ns, and t<sub>f</sub> = 50 ns is calculated using following expression.

$$f_{SCL} = 1/(198 \times 52 \text{ ns} + 200 \text{ ns} + 50 \text{ ns}) \cong 94.7 \text{ kHz}$$

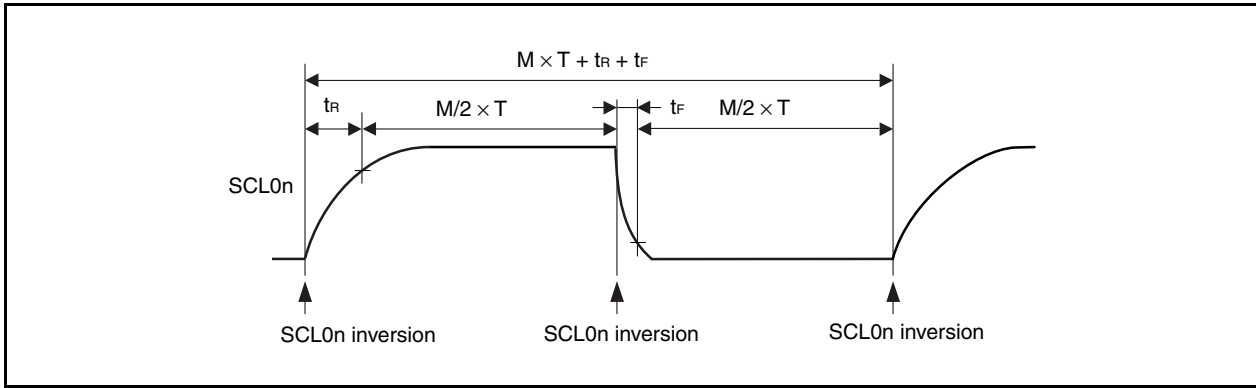

The clock to be selected can be set by the combination of the SMCn, CLn1, and CLn0 bits of the IICCLn register, the CLXn bit of the IICXn register, and the OCKSTHm, OCKSm1, and OCKSm0 bits of the OCKSm register.

<R> **Remark** Only  $\mu$ PD70F3931 (V850E/SJ3-H), 70F3932 (V850E/SJ3-H), and 70F3933 (V850E/SJ3-H):  
 $n = 0$  to  $3$ ,  $m = 0, 1$   
 Other than  $\mu$ PD70F3931 (V850E/SJ3-H), 70F3932 (V850E/SJ3-H), and 70F3933 (V850E/SJ3-H):  
 $n = 0$  to  $5$ ,  $m = 0, 1, 3$

Table 19-5. Clock Settings (1/3)

IICXa	IICCLa			Selection Clock	Transfer Clock	Settable Peripheral Clock Frequency (f <sub>XP</sub> ) Range	Operating Mode	
	Bit 0	Bit 3	Bit 1					Bit 0
	CLXa	SMCa	CLa1					CLa0
0	0	0	0	f <sub>XP</sub> (when OCKS0 = 18H set)	f <sub>XP</sub> /44	2.00 MHz ≤ f <sub>XP</sub> ≤ 4.19 MHz	Standard mode (SMCa bit = 0)	
				f <sub>XP</sub> /2 (when OCKS0 = 10H set)	f <sub>XP</sub> /88	4.00 MHz ≤ f <sub>XP</sub> ≤ 8.38 MHz		
				f <sub>XP</sub> /3 (when OCKS0 = 11H set)	f <sub>XP</sub> /132	6.00 MHz ≤ f <sub>XP</sub> ≤ 12.57 MHz		
				f <sub>XP</sub> /4 (when OCKS0 = 12H set)	f <sub>XP</sub> /176	8.00 MHz ≤ f <sub>XP</sub> ≤ 16.76 MHz		
				f <sub>XP</sub> /5 (when OCKS0 = 13H set)	f <sub>XP</sub> /220	10.00 MHz ≤ f <sub>XP</sub> ≤ 20.95 MHz		
0	0	0	1	f <sub>XP</sub> (when OCKS0 = 18H set)	f <sub>XP</sub> /86	4.19 MHz ≤ f <sub>XP</sub> ≤ 8.38 MHz		
				f <sub>XP</sub> /2 (when OCKS0 = 10H set)	f <sub>XP</sub> /172	8.38 MHz ≤ f <sub>XP</sub> ≤ 16.76 MHz		
				f <sub>XP</sub> /3 (when OCKS0 = 11H set)	f <sub>XP</sub> /258	12.57 MHz ≤ f <sub>XP</sub> ≤ 25.14 MHz		
				f <sub>XP</sub> /4 (when OCKS0 = 12H set)	f <sub>XP</sub> /344	16.76 MHz ≤ f <sub>XP</sub> ≤ 32.00 MHz		
				f <sub>XP</sub> /5 (when OCKS0 = 13H set)	f <sub>XP</sub> /430	20.95 MHz ≤ f <sub>XP</sub> ≤ 32.00 MHz		
0	0	1	0	f <sub>XP</sub> <sup>Note</sup>	f <sub>XP</sub> /86	4.19 MHz ≤ f <sub>XP</sub> ≤ 8.38 MHz		
0	0	1	1	f <sub>XP</sub> (when OCKS0 = 18H set)	f <sub>XP</sub> /66	6.40 MHz		
				f <sub>XP</sub> /2 (when OCKS0 = 10H set)	f <sub>XP</sub> /132	12.80 MHz		
				f <sub>XP</sub> /3 (when OCKS0 = 11H set)	f <sub>XP</sub> /198	19.20 MHz		
				f <sub>XP</sub> /4 (when OCKS0 = 12H set)	f <sub>XP</sub> /264	25.60 MHz		
				f <sub>XP</sub> /5 (when OCKS0 = 13H set)	f <sub>XP</sub> /330	32.00 MHz		
0	1	0	×	f <sub>XP</sub> (when OCKS0 = 18H set)	f <sub>XP</sub> /24	4.19 MHz ≤ f <sub>XP</sub> ≤ 8.38 MHz	High-speed mode (SMCa bit = 1)	
				f <sub>XP</sub> /2 (when OCKS0 = 10H set)	f <sub>XP</sub> /48	8.00 MHz ≤ f <sub>XP</sub> ≤ 16.76 MHz		
				f <sub>XP</sub> /3 (when OCKS0 = 11H set)	f <sub>XP</sub> /72	12.00 MHz ≤ f <sub>XP</sub> ≤ 25.14 MHz		
				f <sub>XP</sub> /4 (when OCKS0 = 12H set)	f <sub>XP</sub> /96	16.00 MHz ≤ f <sub>XP</sub> ≤ 32.00 MHz		
0	1	1	0	f <sub>XP</sub> <sup>Note</sup>	f <sub>XP</sub> /24	4.00 MHz ≤ f <sub>XP</sub> ≤ 8.38 MHz		
0	1	1	1	f <sub>XP</sub> (when OCKS0 = 18H set)	f <sub>XP</sub> /18	6.40 MHz		
				f <sub>XP</sub> /2 (when OCKS0 = 10H set)	f <sub>XP</sub> /36	12.80 MHz		
				f <sub>XP</sub> /3 (when OCKS0 = 11H set)	f <sub>XP</sub> /54	19.20 MHz		
				f <sub>XP</sub> /4 (when OCKS0 = 12H set)	f <sub>XP</sub> /72	25.60 MHz		
				f <sub>XP</sub> /5 (when OCKS0 = 13H set)	f <sub>XP</sub> /90	32.00 MHz		
1	1	0	×	f <sub>XP</sub> (when OCKS0 = 18H set)	f <sub>XP</sub> /12	4.00 MHz ≤ f <sub>XP</sub> ≤ 4.19 MHz		
				f <sub>XP</sub> /2 (when OCKS0 = 10H set)	f <sub>XP</sub> /24	8.00 MHz ≤ f <sub>XP</sub> ≤ 8.38 MHz		
				f <sub>XP</sub> /3 (when OCKS0 = 11H set)	f <sub>XP</sub> /36	12.00 MHz ≤ f <sub>XP</sub> ≤ 12.57 MHz		
				f <sub>XP</sub> /4 (when OCKS0 = 12H set)	f <sub>XP</sub> /48	16.00 MHz ≤ f <sub>XP</sub> ≤ 16.67 MHz		
				f <sub>XP</sub> /5 (when OCKS0 = 13H set)	f <sub>XP</sub> /60	20.00 MHz ≤ f <sub>XP</sub> ≤ 20.95 MHz		
1	1	1	0	f <sub>XP</sub> <sup>Note</sup>	f <sub>XP</sub> /12	4.00 MHz ≤ f <sub>XP</sub> ≤ 4.19 MHz		
Other than above				Setting prohibited	–	–	–	

**Note** Since the selection clock is f<sub>XP</sub> regardless of the value set to the OCKS0 register, clear the OCKS0 register to 00H (I<sup>2</sup>C division clock stopped status).

- Remarks**
1. a = 0, 3
  2. ×: don't care
  3. f<sub>XP</sub>: Peripheral clock frequency (prescaler 1 input clock frequency)  
Refer to **Remark 2** in **Table 19-1** for details.

Table 19-5. Clock Settings (2/3)

IICXb		IICCLb		Selection Clock	Transfer Clock	Settable Peripheral Clock Frequency (f <sub>XP</sub> ) Range	Operating Mode
Bit 0	Bit 3	Bit 1	Bit 0				
CLXb	SMCb	CLb1	CLb0				
0	0	0	0	f <sub>XP</sub> (when OCKS1 = 18H set)	f <sub>XP</sub> /44	2.00 MHz ≤ f <sub>XP</sub> ≤ 4.19 MHz	Standard mode (SMCb bit = 0)
				f <sub>XP</sub> /2 (when OCKS1 = 10H set)	f <sub>XP</sub> /88	4.00 MHz ≤ f <sub>XP</sub> ≤ 8.38 MHz	
				f <sub>XP</sub> /3 (when OCKS1 = 11H set)	f <sub>XP</sub> /132	6.00 MHz ≤ f <sub>XP</sub> ≤ 12.57 MHz	
				f <sub>XP</sub> /4 (when OCKS1 = 12H set)	f <sub>XP</sub> /176	8.00 MHz ≤ f <sub>XP</sub> ≤ 16.76 MHz	
				f <sub>XP</sub> /5 (when OCKS1 = 13H set)	f <sub>XP</sub> /220	10.00 MHz ≤ f <sub>XP</sub> ≤ 20.95 MHz	
0	0	0	1	f <sub>XP</sub> (when OCKS1 = 18H set)	f <sub>XP</sub> /86	4.19 MHz ≤ f <sub>XP</sub> ≤ 8.38 MHz	
				f <sub>XP</sub> /2 (when OCKS1 = 10H set)	f <sub>XP</sub> /172	8.38 MHz ≤ f <sub>XP</sub> ≤ 16.76 MHz	
				f <sub>XP</sub> /3 (when OCKS1 = 11H set)	f <sub>XP</sub> /258	12.57 MHz ≤ f <sub>XP</sub> ≤ 25.14 MHz	
				f <sub>XP</sub> /4 (when OCKS1 = 12H set)	f <sub>XP</sub> /344	16.76 MHz ≤ f <sub>XP</sub> ≤ 32.00 MHz	
				f <sub>XP</sub> /5 (when OCKS1 = 13H set)	f <sub>XP</sub> /430	20.95 MHz ≤ f <sub>XP</sub> ≤ 32.00 MHz	
0	0	1	0	f <sub>XP</sub> <sup>Note</sup>	f <sub>XP</sub> /86	4.19 MHz ≤ f <sub>XP</sub> ≤ 8.38 MHz	
0	0	1	1	f <sub>XP</sub> (when OCKS1 = 18H set)	f <sub>XP</sub> /66	6.40 MHz	
				f <sub>XP</sub> /2 (when OCKS1 = 10H set)	f <sub>XP</sub> /132	12.80 MHz	
				f <sub>XP</sub> /3 (when OCKS1 = 11H set)	f <sub>XP</sub> /198	19.20 MHz	
				f <sub>XP</sub> /4 (when OCKS1 = 12H set)	f <sub>XP</sub> /264	25.60 MHz	
				f <sub>XP</sub> /5 (when OCKS1 = 13H set)	f <sub>XP</sub> /330	32.00 MHz	
0	1	0	×	f <sub>XP</sub> (when OCKS1 = 18H set)	f <sub>XP</sub> /24	4.19 MHz ≤ f <sub>XP</sub> ≤ 8.38 MHz	High-speed mode (SMCb bit = 1)
				f <sub>XP</sub> /2 (when OCKS1 = 10H set)	f <sub>XP</sub> /48	8.00 MHz ≤ f <sub>XP</sub> ≤ 16.76 MHz	
				f <sub>XP</sub> /3 (when OCKS1 = 11H set)	f <sub>XP</sub> /72	12.00 MHz ≤ f <sub>XP</sub> ≤ 25.14 MHz	
				f <sub>XP</sub> /4 (when OCKS1 = 12H set)	f <sub>XP</sub> /96	16.00 MHz ≤ f <sub>XP</sub> ≤ 32.00 MHz	
0	1	1	0	f <sub>XP</sub> <sup>Note</sup>	f <sub>XP</sub> /24	4.00 MHz ≤ f <sub>XP</sub> ≤ 8.38 MHz	
0	1	1	1	f <sub>XP</sub> (when OCKS1 = 18H set)	f <sub>XP</sub> /18	6.40 MHz	
				f <sub>XP</sub> /2 (when OCKS1 = 10H set)	f <sub>XP</sub> /36	12.80 MHz	
				f <sub>XP</sub> /3 (when OCKS1 = 11H set)	f <sub>XP</sub> /54	19.20 MHz	
				f <sub>XP</sub> /4 (when OCKS1 = 12H set)	f <sub>XP</sub> /72	25.60 MHz	
				f <sub>XP</sub> /5 (when OCKS1 = 13H set)	f <sub>XP</sub> /90	32.00 MHz	
1	1	0	×	f <sub>XP</sub> (when OCKS1 = 18H set)	f <sub>XP</sub> /12	4.00 MHz ≤ f <sub>XP</sub> ≤ 4.19 MHz	
				f <sub>XP</sub> /2 (when OCKS1 = 10H set)	f <sub>XP</sub> /24	8.00 MHz ≤ f <sub>XP</sub> ≤ 8.38 MHz	
				f <sub>XP</sub> /3 (when OCKS1 = 11H set)	f <sub>XP</sub> /36	12.00 MHz ≤ f <sub>XP</sub> ≤ 12.57 MHz	
				f <sub>XP</sub> /4 (when OCKS1 = 12H set)	f <sub>XP</sub> /48	16.00 MHz ≤ f <sub>XP</sub> ≤ 16.67 MHz	
				f <sub>XP</sub> /5 (when OCKS1 = 13H set)	f <sub>XP</sub> /60	20.00 MHz ≤ f <sub>XP</sub> ≤ 20.95 MHz	
1	1	1	0	f <sub>XP</sub> <sup>Note</sup>	f <sub>XP</sub> /12	4.00 MHz ≤ f <sub>XP</sub> ≤ 4.19 MHz	
Other than above				Setting prohibited	–	–	–

**Note** Since the selection clock is f<sub>XP</sub> regardless of the value set to the OCKS1 register, clear the OCKS1 register to 00H (I<sup>2</sup>C division clock stopped status).

- Remarks**
1. b = 1, 2
  2. ×: don't care
  3. f<sub>XP</sub>: Peripheral clock frequency (prescaler 1 input clock frequency)
- Refer to **Remark 2** in **Table 19-1** for details.



Table 19-5. Clock Settings (3/3)

IICXk	IICCLK			Selection Clock	Transfer Clock	Settable Peripheral Clock Frequency (f <sub>XP</sub> ) Range	Operating Mode	
	Bit 0	Bit 3	Bit 1					Bit 0
	CLXk	SMCk	CLK1					CLK0
0	0	0	0	f <sub>XP</sub> (when OCKS3 = 18H set)	f <sub>XP</sub> /44	2.00 MHz ≤ f <sub>XP</sub> ≤ 4.19 MHz	Standard mode (SMCk bit = 0)	
				f <sub>XP</sub> /2 (when OCKS3 = 10H set)	f <sub>XP</sub> /88	4.00 MHz ≤ f <sub>XP</sub> ≤ 8.38 MHz		
				f <sub>XP</sub> /3 (when OCKS3 = 11H set)	f <sub>XP</sub> /132	6.00 MHz ≤ f <sub>XP</sub> ≤ 12.57 MHz		
				f <sub>XP</sub> /4 (when OCKS3 = 12H set)	f <sub>XP</sub> /176	8.00 MHz ≤ f <sub>XP</sub> ≤ 16.76 MHz		
				f <sub>XP</sub> /5 (when OCKS3 = 13H set)	f <sub>XP</sub> /220	10.00 MHz ≤ f <sub>XP</sub> ≤ 20.95 MHz		
0	0	0	1	f <sub>XP</sub> (when OCKS3 = 18H set)	f <sub>XP</sub> /86	4.19 MHz ≤ f <sub>XP</sub> ≤ 8.38 MHz		
				f <sub>XP</sub> /2 (when OCKS3 = 10H set)	f <sub>XP</sub> /172	8.38 MHz ≤ f <sub>XP</sub> ≤ 16.76 MHz		
				f <sub>XP</sub> /3 (when OCKS3 = 11H set)	f <sub>XP</sub> /258	12.57 MHz ≤ f <sub>XP</sub> ≤ 25.14 MHz		
				f <sub>XP</sub> /4 (when OCKS3 = 12H set)	f <sub>XP</sub> /344	16.76 MHz ≤ f <sub>XP</sub> ≤ 32.00 MHz		
				f <sub>XP</sub> /5 (when OCKS3 = 13H set)	f <sub>XP</sub> /430	20.95 MHz ≤ f <sub>XP</sub> ≤ 32.00 MHz		
0	0	1	0	f <sub>XP</sub> <sup>Note</sup>	f <sub>XP</sub> /86	4.19 MHz ≤ f <sub>XP</sub> ≤ 8.38 MHz		
0	0	1	1	Setting prohibited	–	–		
0	1	0	×	f <sub>XP</sub> (when OCKS3 = 18H set)	f <sub>XP</sub> /24	4.19 MHz ≤ f <sub>XP</sub> ≤ 8.38 MHz	High-speed mode (SMCk bit = 1)	
				f <sub>XP</sub> /2 (when OCKS3 = 10H set)	f <sub>XP</sub> /48	8.00 MHz ≤ f <sub>XP</sub> ≤ 16.76 MHz		
				f <sub>XP</sub> /3 (when OCKS3 = 11H set)	f <sub>XP</sub> /72	12.00 MHz ≤ f <sub>XP</sub> ≤ 25.14 MHz		
				f <sub>XP</sub> /4 (when OCKS3 = 12H set)	f <sub>XP</sub> /96	16.00 MHz ≤ f <sub>XP</sub> ≤ 32.00 MHz		
0	1	1	0	f <sub>XP</sub> <sup>Note</sup>	f <sub>XP</sub> /24	4.00 MHz ≤ f <sub>XP</sub> ≤ 8.38 MHz		
0	1	1	1	Setting prohibited	–	–		
1	1	0	×	f <sub>XP</sub> (when OCKS3 = 18H set)	f <sub>XP</sub> /12	4.00 MHz ≤ f <sub>XP</sub> ≤ 4.19 MHz		
				f <sub>XP</sub> /2 (when OCKS3 = 10H set)	f <sub>XP</sub> /24	8.00 MHz ≤ f <sub>XP</sub> ≤ 8.38 MHz		
				f <sub>XP</sub> /3 (when OCKS3 = 11H set)	f <sub>XP</sub> /36	12.00 MHz ≤ f <sub>XP</sub> ≤ 12.57 MHz		
				f <sub>XP</sub> /4 (when OCKS3 = 12H set)	f <sub>XP</sub> /48	16.00 MHz ≤ f <sub>XP</sub> ≤ 16.67 MHz		
				f <sub>XP</sub> /5 (when OCKS3 = 13H set)	f <sub>XP</sub> /60	20.00 MHz ≤ f <sub>XP</sub> ≤ 20.95 MHz		
1	1	1	0	f <sub>XP</sub> <sup>Note</sup>	f <sub>XP</sub> /12	4.00 MHz ≤ f <sub>XP</sub> ≤ 4.19 MHz		
Other than above				Setting prohibited	–	–	–	

**Note** Since the selection clock is f<sub>XP</sub> regardless of the value set to the OCKS3 register, clear the OCKS3 register to 00H (I<sup>2</sup>C division clock stopped status).

- Remarks**
- k = 4, 5
  - ×: don't care
  - f<sub>XP</sub>: Peripheral clock frequency (prescaler 1 input clock frequency)  
Refer to **Remark 2** in **Table 19-1** for details.

**(7) IIC division clock select register m (OCKSm)**

The OCKSm registers control the I<sup>2</sup>C0n division clock.

These registers control the I<sup>2</sup>C00 and I<sup>2</sup>C03 division clock via the OCKS0 register, the I<sup>2</sup>C01 and I<sup>2</sup>C02 division clocks via the OCKS1 register, and the I<sup>2</sup>C04 and I<sup>2</sup>C05 division clocks via the OCKS3 register.

These registers can be read or written in 8-bit units.

Reset sets these registers to 00H.

<R>

After reset: 00H R/W Address: OCKS0 FFFFF340H, OCKS1 FFFFF344H, OCKS3 FFFFF34CH<sup>Note</sup>

	7	6	5	4	3	2	1	0
OCKSm	0	0	0	OCKSENm	OCKSTHm	0	OCKSm1	OCKSm0

OCKSENm	Operation setting of I <sup>2</sup> C division clock
0	Disable I <sup>2</sup> C division clock operation
1	Enable I <sup>2</sup> C division clock operation

OCKSTHm	OCKSm1	OCKSm0	Selection of I <sup>2</sup> C division clock
0	0	0	f <sub>XP</sub> /2
0	0	1	f <sub>XP</sub> /3
0	1	0	f <sub>XP</sub> /4
0	1	1	f <sub>XP</sub> /5
1	0	0	f <sub>XP</sub>
Other than above			Setting prohibited

<R>

**Note** Other than the  $\mu$ PD70F3931 (V850E/SJ3-H), 70F3932 (V850E/SJ3-H), and 70F3933 (V850E/SJ3-H)

<R>

- Remarks**
- Only  $\mu$ PD70F3931 (V850E/SJ3-H), 70F3932 (V850E/SJ3-H), 70F3933 (V850E/SJ3-H): m = 0, 1  
Other than  $\mu$ PD70F3931 (V850E/SJ3-H), 70F3932 (V850E/SJ3-H), 70F3933 (V850E/SJ3-H): m = 0, 1, 3
  - f<sub>XP</sub>: Peripheral clock frequency (prescaler 1 input clock frequency)  
In clock mode 1, f<sub>XP</sub> = f<sub>XX</sub>  
In clock mode 2, f<sub>XP</sub> = f<sub>XMPLL</sub>/2 (14.64 to 16 MHz)  
In clock mode 3, f<sub>XP</sub> = f<sub>XMPLL</sub> (29.28 to 32 MHz)  
In clock mode 4, f<sub>XP</sub> = f<sub>XMPLL</sub>/2 (20.88 to 24 MHz)  
f<sub>XX</sub>: Main clock frequency  
f<sub>XMPLL</sub>: PLL output clock frequency for peripheral clock

**(8) IIC shift register n (IICn)**

The IICn registers are used for serial transmission/reception (shift operations) synchronized with the serial clock. These registers can be read or written in 8-bit units, but data should not be written to the IICn register during a data transfer.

Access (read/write) the IICn register only during the wait period. Accessing this register in communication states other than the wait period is prohibited. However, for the master device, the IICn register can be written once only after the transmission trigger bit (IICn.STTn bit) has been set to 1.

A wait state is released by writing the IICn register during the wait period, and data transfer is started.

Reset sets these registers to 00H.

<R>

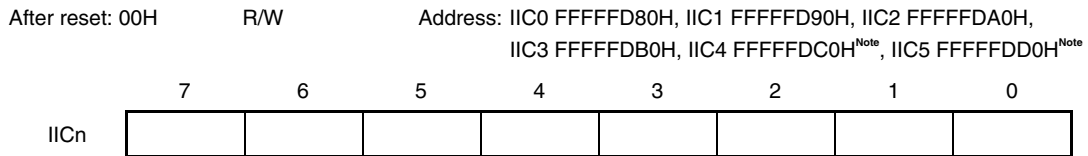

<R>

**Note** Other than the  $\mu$ PD70F3931 (V850E/SJ3-H), 70F3932 (V850E/SJ3-H), and 70F3933 (V850E/SJ3-H)

<R>

**Remark** Only  $\mu$ PD70F3931 (V850E/SJ3-H), 70F3932 (V850E/SJ3-H), and 70F3933 (V850E/SJ3-H):  
n = 0 to 3  
Other than  $\mu$ PD70F3931 (V850E/SJ3-H), 70F3932 (V850E/SJ3-H), and 70F3933 (V850E/SJ3-H):  
n = 0 to 5

**(9) Slave address register n (SVAn)**

The SVAn registers hold the I<sup>2</sup>C bus's slave addresses.

These registers can be read or written in 8-bit units, but bit 0 should be fixed to 0. However, rewriting these registers is prohibited when the IICSn.STDn bit = 1 (start condition detection).

Reset sets these registers to 00H.

<R>

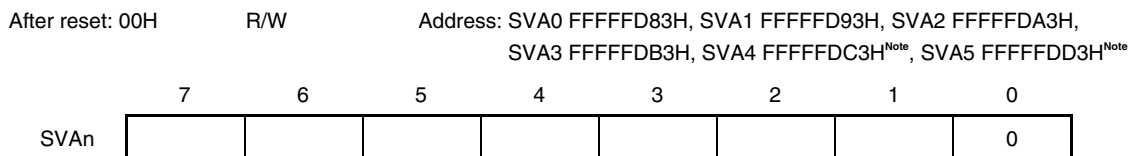

<R>

**Note** Other than the  $\mu$ PD70F3931 (V850E/SJ3-H), 70F3932 (V850E/SJ3-H), and 70F3933 (V850E/SJ3-H)

<R>

**Remark** Only  $\mu$ PD70F3931 (V850E/SJ3-H), 70F3932 (V850E/SJ3-H), and 70F3933 (V850E/SJ3-H):  
n = 0 to 3  
Other than  $\mu$ PD70F3931 (V850E/SJ3-H), 70F3932 (V850E/SJ3-H), and 70F3933 (V850E/SJ3-H):  
n = 0 to 5

## 19.5 I<sup>2</sup>C Bus Mode Functions

### 19.5.1 Pin configuration

The serial clock pin (SCL0n) and serial data bus pin (SDA0n) are configured as follows.

SCL0n .....This pin is used for serial clock input and output.

This pin is an N-ch open-drain output for both master and slave devices. Input is Schmitt input.

SDA0n .....This pin is used for serial data input and output.

This pin is an N-ch open-drain output for both master and slave devices. Input is Schmitt input.

Since outputs from the serial clock line and the serial data bus line are N-ch open-drain outputs, an external pull-up resistor is required.

**Figure 19-3. Pin Configuration Diagram**

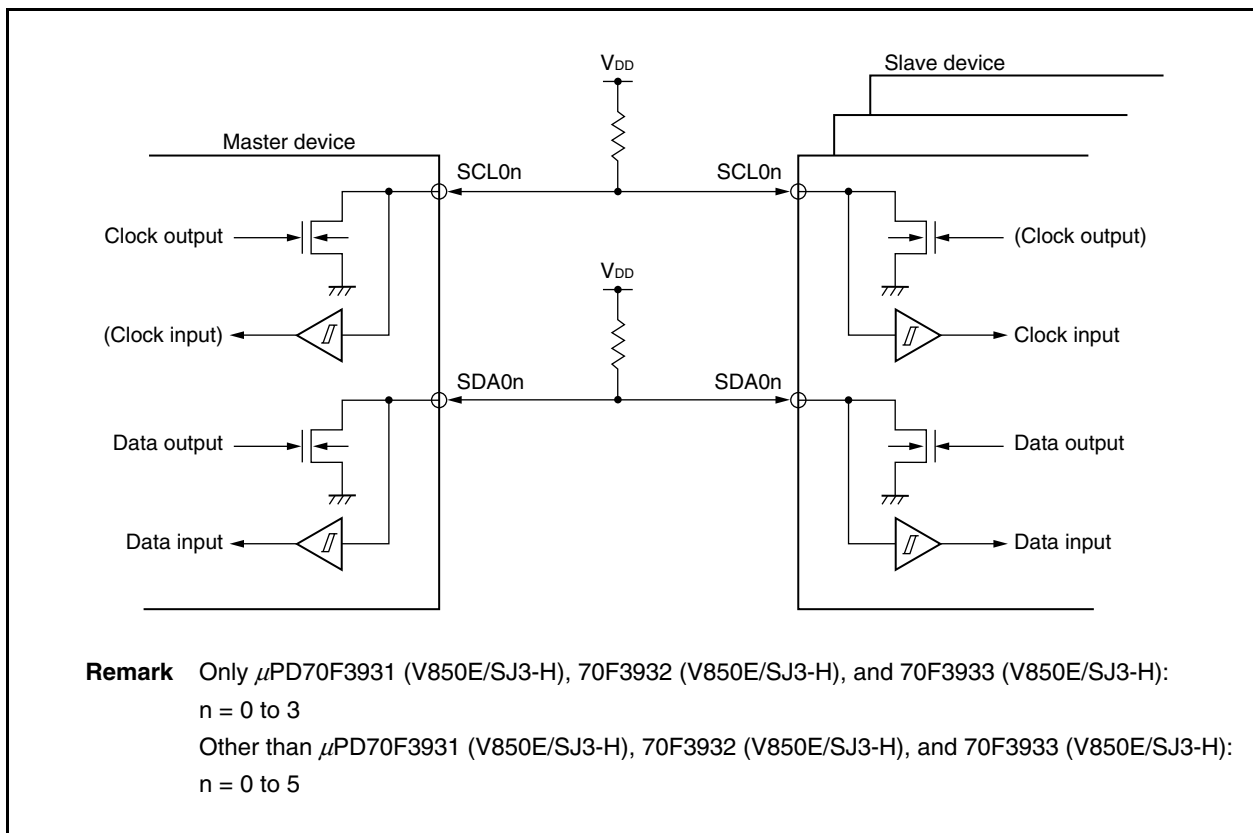

<R>

## 19.6 I<sup>2</sup>C Bus Definitions and Control Methods

The following section describes the I<sup>2</sup>C bus's serial data communication format and the signals used by the I<sup>2</sup>C bus. The transfer timing for the "start condition", "address", "transfer direction specification", "data", and "stop condition" generated on the I<sup>2</sup>C bus's serial data bus is shown below.

**Figure 19-4. I<sup>2</sup>C Bus Serial Data Transfer Timing**

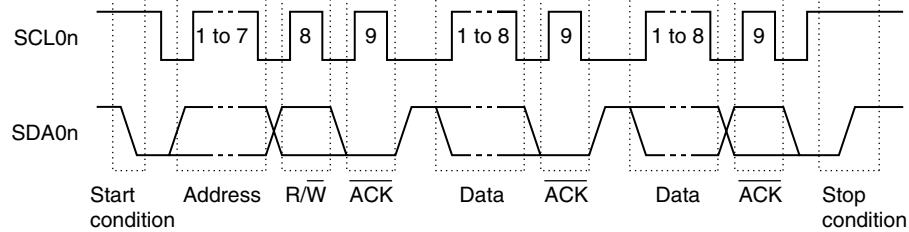

**Remark** Only  $\mu$ PD70F3931 (V850E/SJ3-H), 70F3932 (V850E/SJ3-H), and 70F3933 (V850E/SJ3-H):  
 n = 0 to 3  
 Other than  $\mu$ PD70F3931 (V850E/SJ3-H), 70F3932 (V850E/SJ3-H), and 70F3933 (V850E/SJ3-H):  
 n = 0 to 5

The master device generates the start condition, slave address, and stop condition.

$\overline{\text{ACK}}$  can be generated by either the master or slave device (normally, it is generated by the device that receives 8-bit data).

The serial clock (SCL0n) is continuously output by the master device. However, in the slave device, the SCL0n pin's low-level period can be extended and a wait state can be inserted.

<R>

### 19.6.1 Start condition

A start condition is met when the SCL0n pin is high level and the SDA0n pin changes from high level to low level. The start condition for the SCL0n and SDA0n pins is generated that the master device to the slave device when starting a serial transfer. The slave device can detect the start condition.

**Figure 19-5. Start Condition**

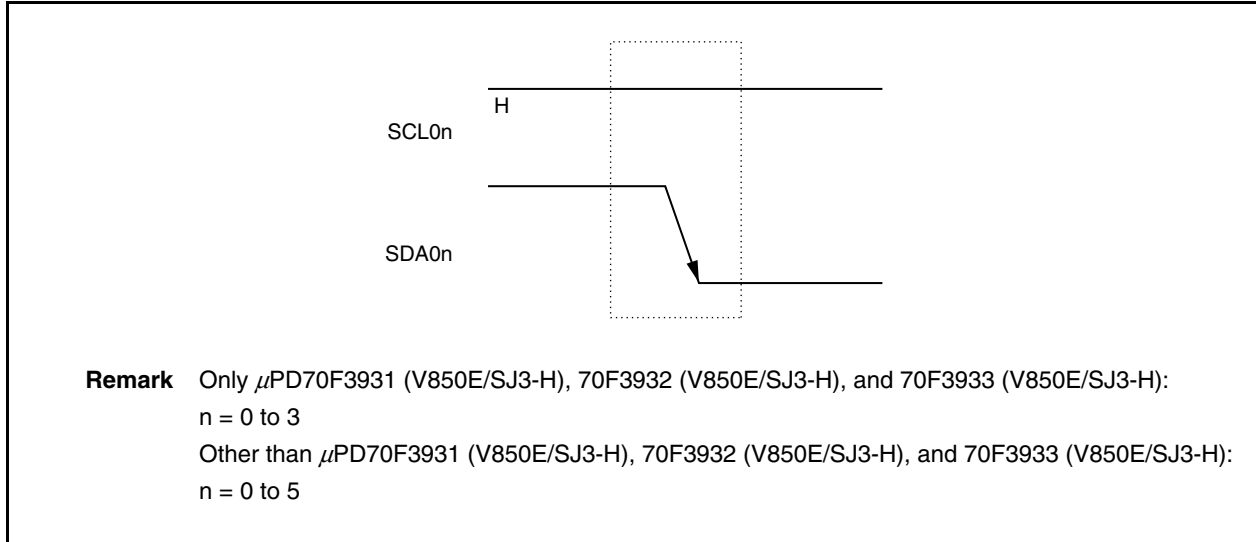

A start condition is generated when the IICn.STTn bit is set (1) after a stop condition has been detected (IICn.SPn bit = 1). When a start condition is detected, the IICn.STDn bit is set (1).

**Caution** When the IICn.IICEn bit of the V850E/SJ3-H and V850E/SK3-H is set to 1 while communications with other devices are in progress, the start condition may be detected depending on the status of the communication line. Be sure to set the IICn.IICEn bit to 1 when the SCL0n and SDA0n lines are high level.

**19.6.2 Addresses**

The 7 bits of data that follow the start condition are defined as an address.

An address is a 7-bit data segment that is output in order to select one of the slave devices that are connected to the master device via the bus lines. Therefore, each slave device connected via the bus lines must have a unique address.

The slave devices include hardware that detects the start condition and checks whether or not the 7-bit address data matches the data values stored in the SVAn register. If the address data matches the values of the SVAn register, the slave device is selected and communicates with the master device until the master device generates a start condition or stop condition.

**Figure 19-6. Address**

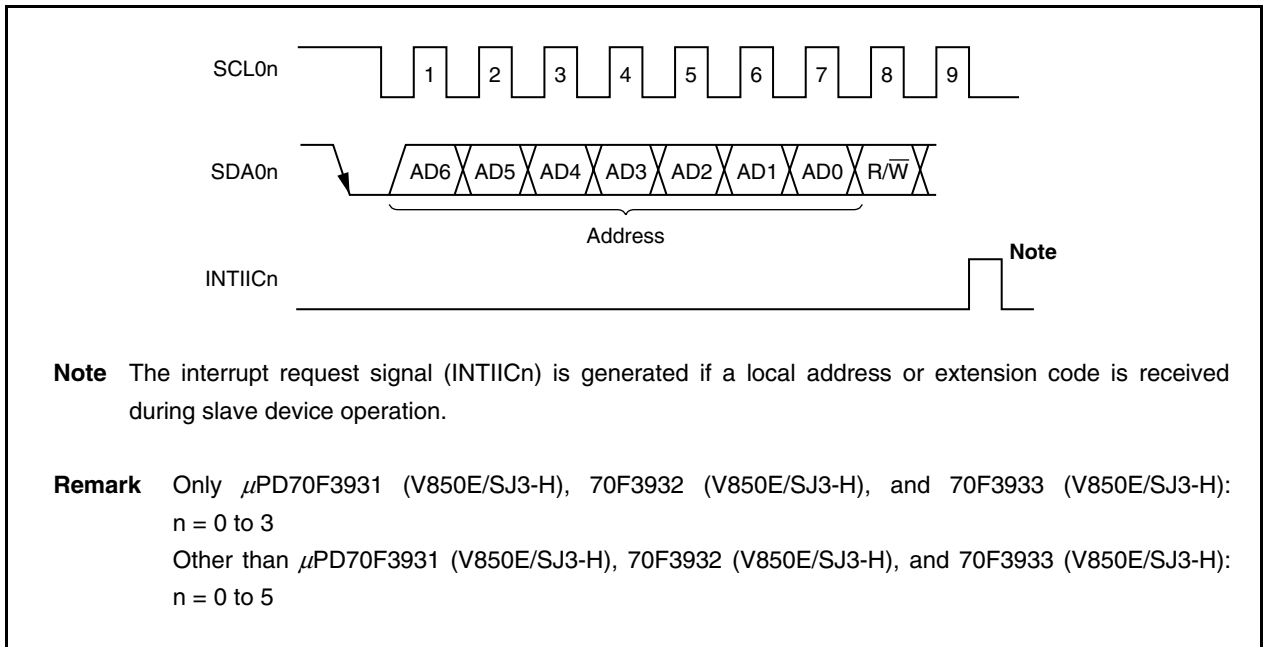

<R>

The slave address and the eighth bit, which specifies the transfer direction as described in **19.6.3 Transfer direction specification** below, are written together to IIC shift register n (IICn) and then output. Received addresses are written to the IICn register.

The slave address is assigned to the higher 7 bits of the IICn register.

**19.6.3 Transfer direction specification**

In addition to the 7-bit address data, the master device sends 1 bit that specifies the transfer direction. When this transfer direction specification bit has a value of 0, it indicates that the master device is transmitting data to a slave device. When the transfer direction specification bit has a value of 1, it indicates that the master device is receiving data from a slave device.

**Figure 19-7. Transfer Direction Specification**

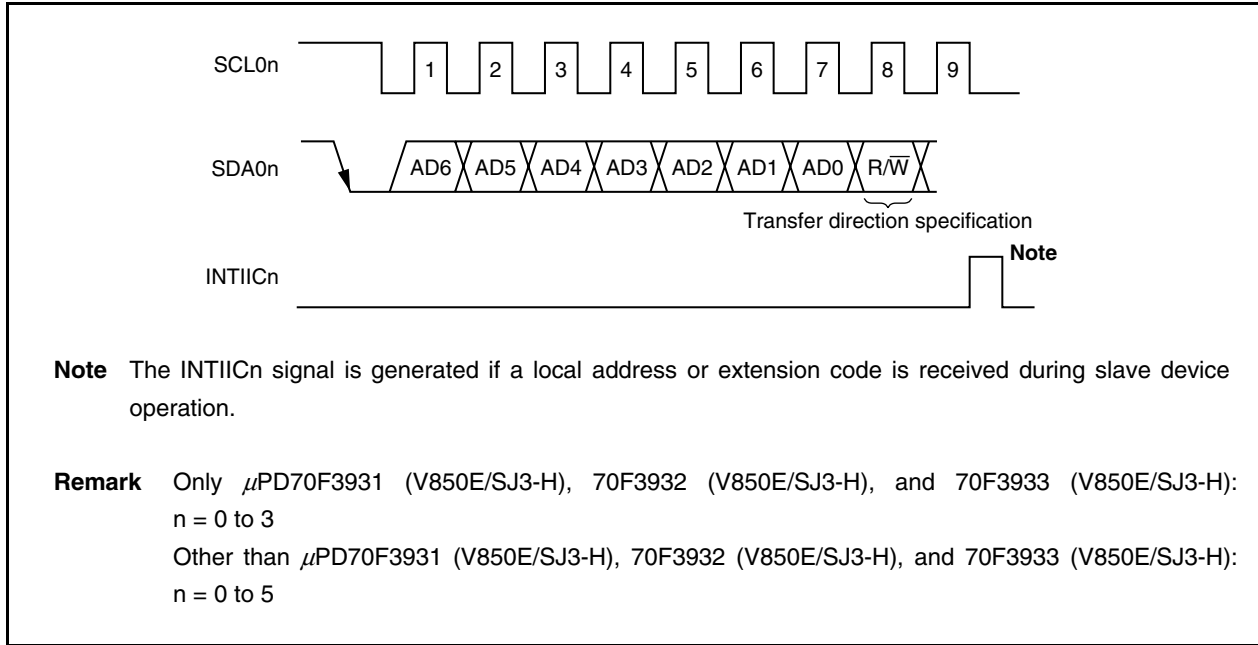

<R>



19.6.4  $\overline{\text{ACK}}$

$\overline{\text{ACK}}$  is used to confirm the serial data status of the transmitting and receiving devices.

The receiving device returns  $\overline{\text{ACK}}$  for every 8 bits of data it receives.

The transmitting device normally receives  $\overline{\text{ACK}}$  after transmitting 8 bits of data. When  $\overline{\text{ACK}}$  is returned from the receiving device, the reception is judged as normal and processing continues. The detection of  $\overline{\text{ACK}}$  is confirmed with the IICSn.ACKDn bit.

When the master device is the receiving device, after receiving the final data, it does not return  $\overline{\text{ACK}}$  and generates the stop condition. When the slave device is the receiving device and does not return  $\overline{\text{ACK}}$ , the master device generates either a stop condition or a restart condition, and then stops the current transmission. Failure to return  $\overline{\text{ACK}}$  may be caused by the following factors.

- (a) Reception was not performed normally.
- (b) The final data was received.
- (c) The receiving device (slave) does not exist for the specified address.

When the receiving device sets the SDA0n line to low level during the ninth clock,  $\overline{\text{ACK}}$  is generated (normal reception).

When the IICCN.ACKEn bit is set to 1, automatic  $\overline{\text{ACK}}$  generation is enabled. Transmission of the eighth bit following the 7 address data bits causes the IICSn.TRCn bit to be set. Normally, set the ACKEn bit to 1 for reception (TRCn bit = 0).

When the slave device is receiving (when TRCn bit = 0), if the slave device cannot receive data, clear the ACKEn bit to 0 to indicate to the master that no more data can be received.

Similarly, when the master device is receiving (when TRCn bit = 0) and the subsequent data is not needed, clear the ACKEn bit to 0 to prevent  $\overline{\text{ACK}}$  from being generated. This notifies the slave device (transmitting device) of the end of the data transmission (transmission stopped).

Figure 19-8.  $\overline{\text{ACK}}$

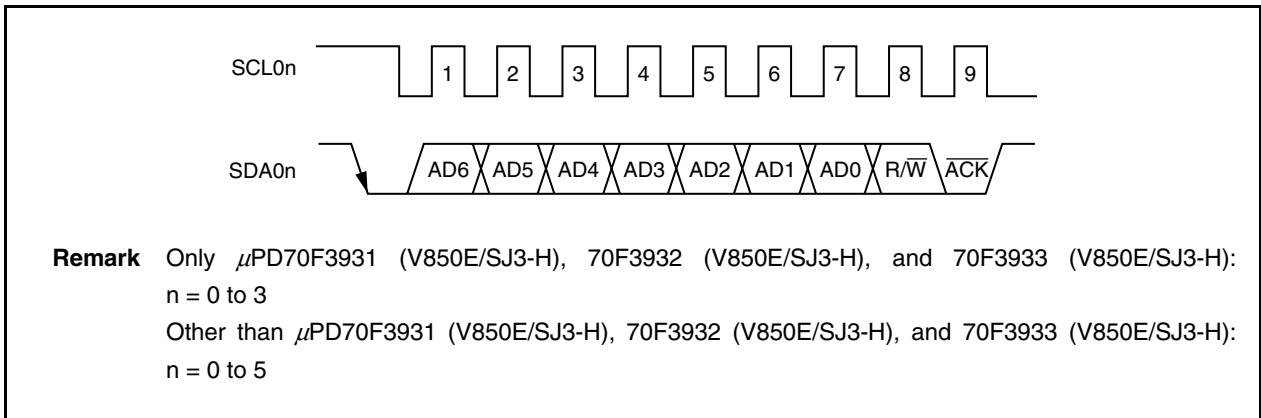

When the local address is received,  $\overline{\text{ACK}}$  is automatically generated regardless of the value of the ACKEn bit. No  $\overline{\text{ACK}}$  is generated if the received address is not a local address (NACK).

When receiving the extension code, set the ACKEn bit to 1 in advance to generate  $\overline{\text{ACK}}$ .

The  $\overline{\text{ACK}}$  generation method during data reception is based on the wait timing setting, as described by the following.

- When 8-clock wait is selected (IICCN.WTIMn bit = 0):  
 $\overline{\text{ACK}}$  is generated at the falling edge of the SCL0n pin's eighth clock if the ACKEn bit is set to 1 before the wait state cancellation.
- When 9-clock wait is selected (IICCN.WTIMn bit = 1):  
 $\overline{\text{ACK}}$  is generated if the ACKEn bit is set to 1 in advance.

### 19.6.5 Stop condition

When the SCL0n pin is high level, changing the SDA0n pin from low level to high level generates a stop condition.

A stop condition is generated when serial transfer from the master device to the slave device has been completed. When used as the slave device, the start condition can be detected.

**Figure 19-9. Stop Condition**

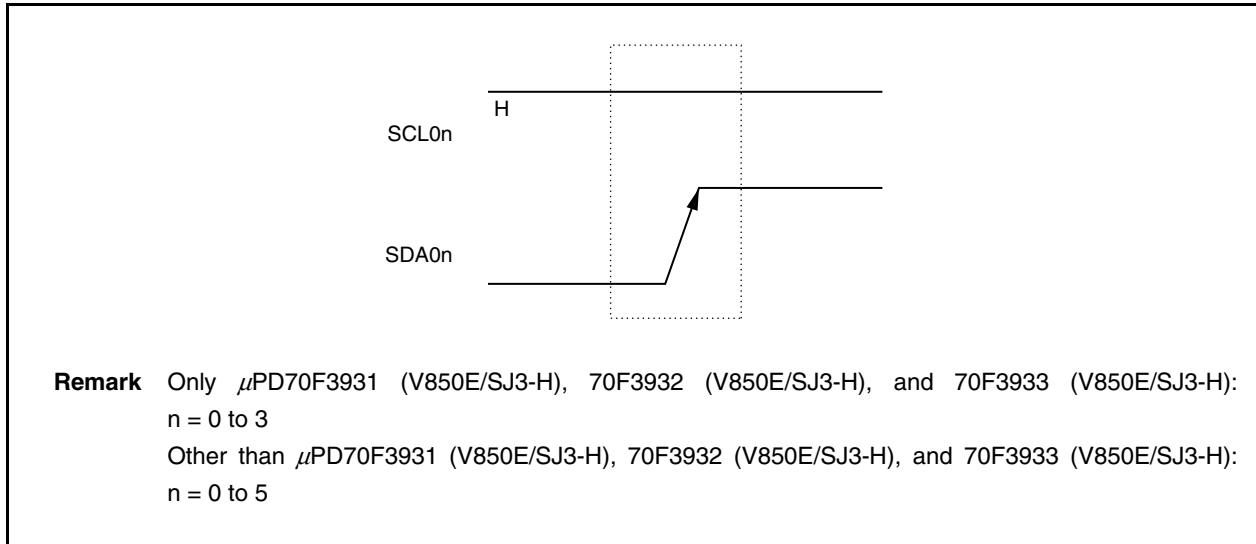

A stop condition is generated when the IICn.SPTn bit is set to 1. When the stop condition is detected, the IICn.SPDn bit is set to 1 and the interrupt request signal (INTIICn) is generated when the IICn.SPIEn bit is set to 1.

19.6.6 Wait state

A wait state is used to notify the communication partner that a device (master or slave) is preparing to transmit or receive data (i.e., is in a wait state).

Setting the SCL0n pin to low level notifies the communication partner of the wait state. When the wait state has been canceled for both the master and slave devices, the next data transfer can begin.

Figure 19-10. Wait State (1/2)

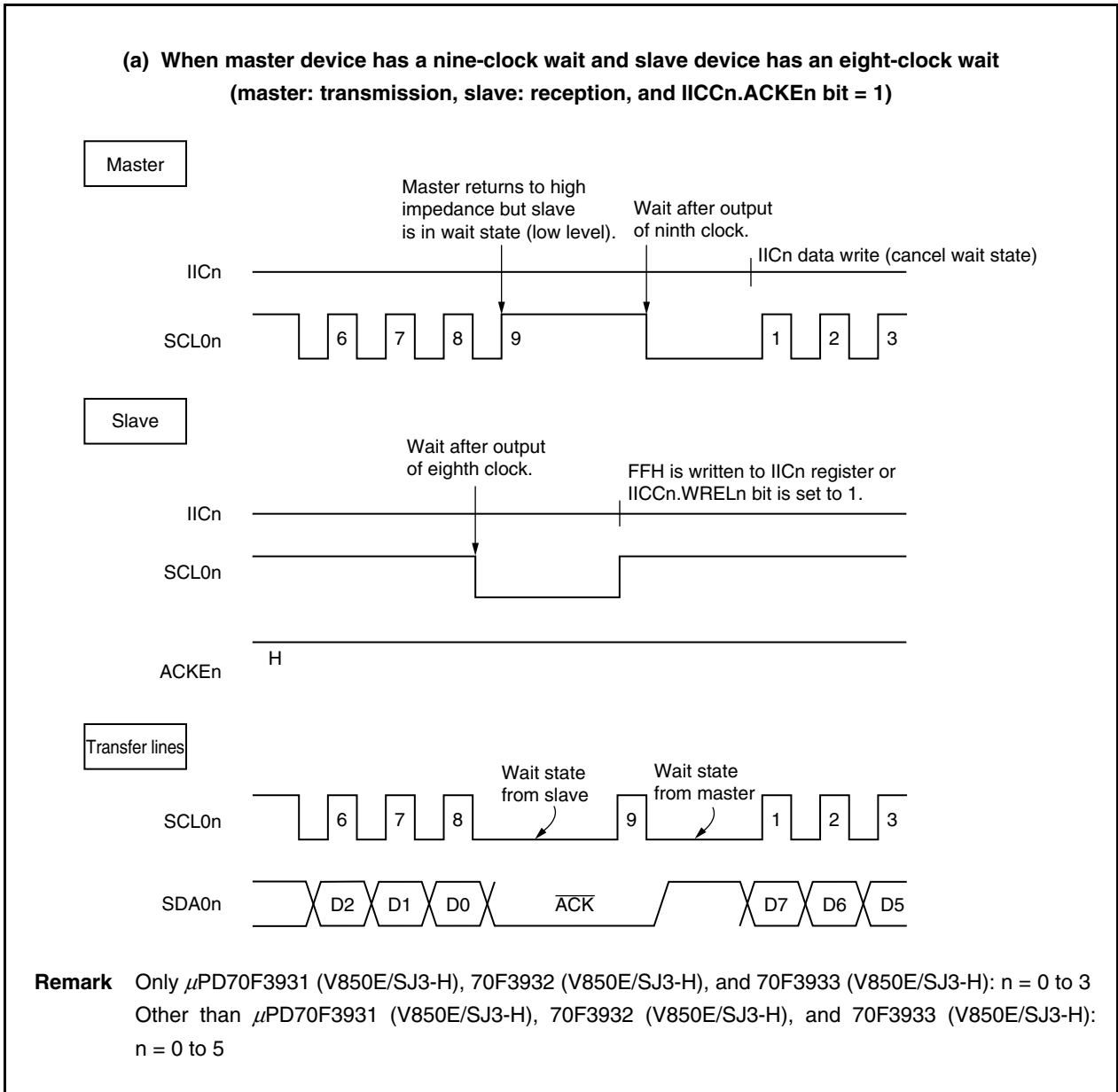

<R>

Figure 19-10. Wait State (2/2)

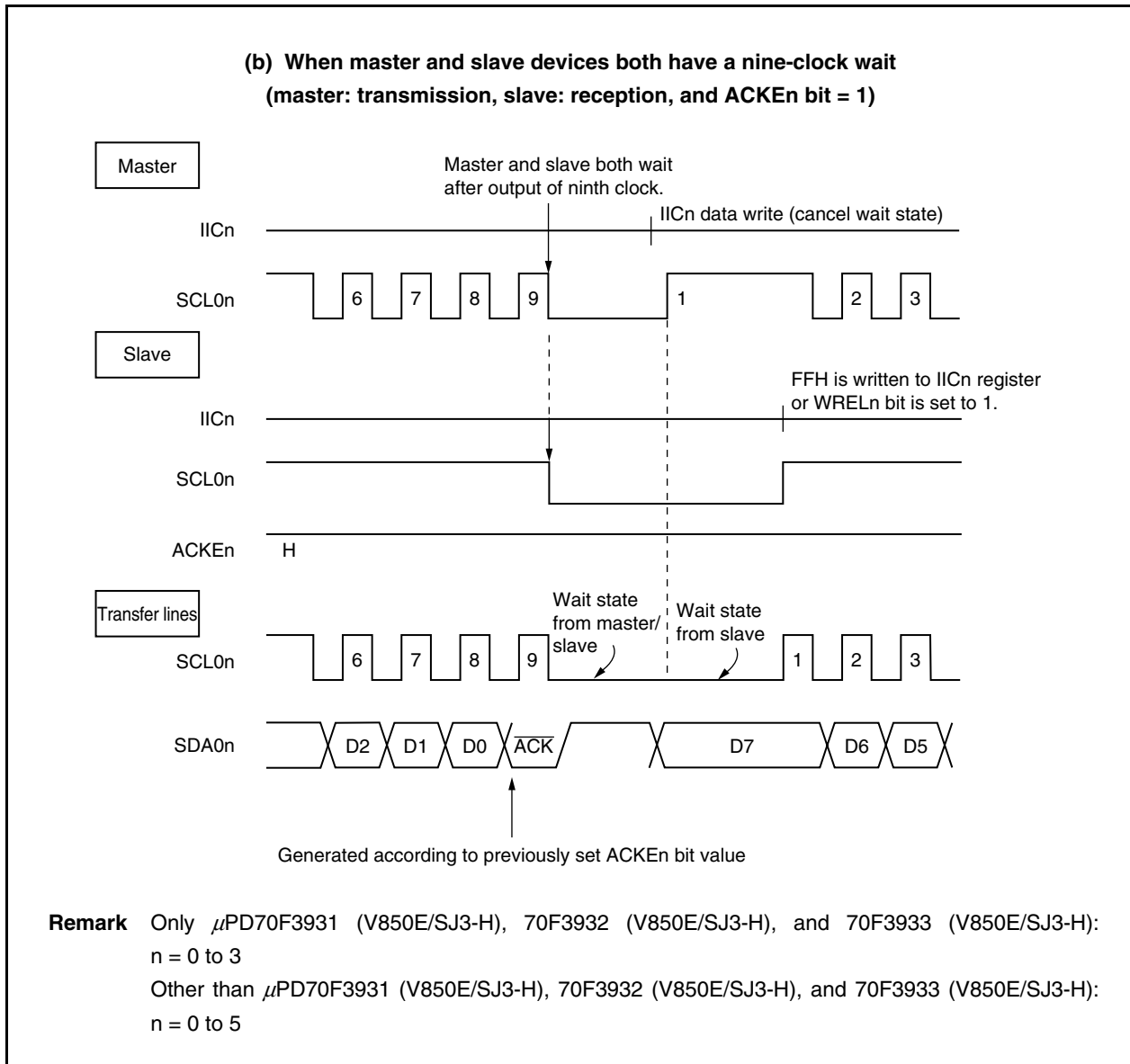

A wait state is automatically generated after generation of the start condition. A wait state is also automatically generated depending on the setting of the IICn.WTIMn bit.

Normally, when the IICn.WRELn bit is set to 1 or when FFH is written to the IICn register on the receiving side, the wait state is canceled and the transmitting side writes data to the IICn register to cancel the wait state.

The master device can also cancel the wait state via either of the following methods.

- By setting the IICn.STTn bit to 1
- By setting the IICn.SPTn bit to 1

### 19.6.7 Wait state cancellation method

In the case of I<sup>2</sup>C0n, wait state can be canceled normally in the following ways.

- By writing data to the IICn register
- By setting the IICn.WRELn bit to 1 (wait state cancellation)
- By setting the IICn.STTn bit to 1 (start condition generation)<sup>Note</sup>
- By setting the IICn.SPTn bit to 1 (stop condition generation)<sup>Note</sup>

**Note** Master only

If any of these wait state cancellation actions is performed, I<sup>2</sup>C0n will cancel wait state and restart communication.

When canceling wait state and sending data (including address), write data to the IICn register.

To receive data after canceling wait state, or to complete data transmission, set the WRELn bit to 1.

To generate a restart condition after canceling wait state, set the STTn bit to 1.

To generate a stop condition after canceling wait state, set the SPTn bit to 1.

Execute cancellation only once for each wait state.

For example, if data is written to the IICn register following wait state cancellation by setting the WRELn bit to 1, conflict between the SDAn line change timing and IICn register write timing may result in the data output to the SDAn line may be incorrect.

Even in other operations, if communication is stopped halfway, clearing the IICn.IICEn bit to 0 will stop communication, enabling wait state to be cancelled.

If the I<sup>2</sup>C bus dead-locks due to noise, etc., setting the IICn.LRELn bit to 1 causes the communication operation to be exited, enabling wait state to be cancelled.

<R>

**Remark** Only  $\mu$ PD70F3931 (V850E/SJ3-H), 70F3932 (V850E/SJ3-H), and 70F3933 (V850E/SJ3-H): n = 0 to 3  
Other than  $\mu$ PD70F3931 (V850E/SJ3-H), 70F3932 (V850E/SJ3-H), and 70F3933 (V850E/SJ3-H): n = 0 to 5

## 19.7 I<sup>2</sup>C Interrupt Request Signals (INTIICn)

The following shows the value of the IICSn register at the INTIICn interrupt request signal generation timing and at the INTIICn signal timing.

- Remarks 1.** ST: Start condition  
 AD6 to AD0: Address  
 R/W: Transfer direction specification  
 ACK: Acknowledge  
 D7 to D0: Data  
 SP: Stop condition
- <R> **2.** Only  $\mu$ PD70F3931 (V850E/SJ3-H), 70F3932 (V850E/SJ3-H), and 70F3933 (V850E/SJ3-H):  
 n = 0 to 3  
 Other than  $\mu$ PD70F3931 (V850E/SJ3-H), 70F3932 (V850E/SJ3-H), and 70F3933 (V850E/SJ3-H):  
 n = 0 to 5

19.7.1 Master device operation

(1) Start ~ Address ~ Data ~ Data ~ Stop (normal transmission/reception)

<1> When IICn.WTIMn bit = 0

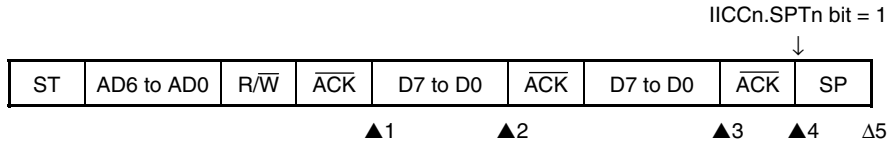

- ▲1: IICSn register = 1000X110B
- ▲2: IICSn register = 1000X000B
- ▲3: IICSn register = 1000X000B (WTIMn bit = 1<sup>Note</sup>)
- ▲4: IICSn register = 1000XX00B
- Δ5: IICSn register = 00000001B

**Note** Set the WTIMn bit (1) and change the timing of generating the interrupt request signal (INTIICn) to generate the stop condition.

**Remarks 1.** ▲: Always generated

- Δ: Generated only when SPIEn bit = 1
- X: don't care

2. Only  $\mu$ PD70F3931 (V850E/SJ3-H), 70F3932 (V850E/SJ3-H), and 70F3933 (V850E/SJ3-H): n = 0 to 3  
 Other than  $\mu$ PD70F3931 (V850E/SJ3-H), 70F3932 (V850E/SJ3-H), and 70F3933 (V850E/SJ3-H): n = 0 to 5

<R>

<2> When WTIMn bit = 1

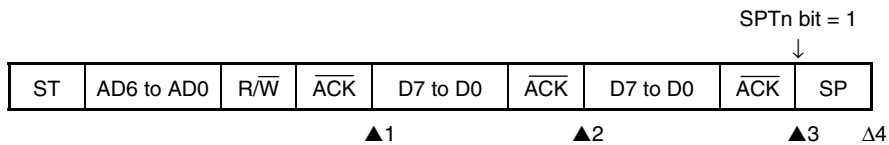

- ▲1: IICSn register = 1000X110B
- ▲2: IICSn register = 1000X100B
- ▲3: IICSn register = 1000XX00B
- Δ4: IICSn register = 00000001B

**Remarks 1.** ▲: Always generated

- Δ: Generated only when SPIEn bit = 1
- X: don't care

2. Only  $\mu$ PD70F3931 (V850E/SJ3-H), 70F3932 (V850E/SJ3-H), and 70F3933 (V850E/SJ3-H): n = 0 to 3  
 Other than  $\mu$ PD70F3931 (V850E/SJ3-H), 70F3932 (V850E/SJ3-H), and 70F3933 (V850E/SJ3-H): n = 0 to 5

<R>

(2) Start ~ Address ~ Data ~ Start ~ Address ~ Data ~ Stop (restart)

<1> When WTIMn bit = 0

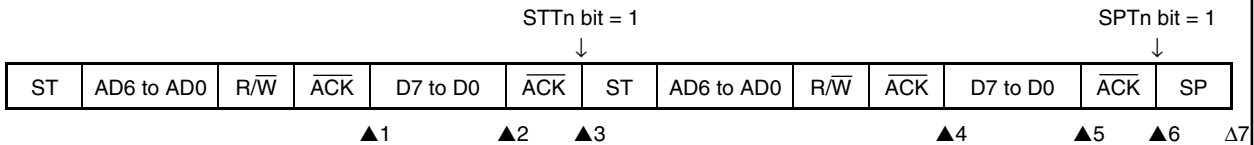

- ▲1: IICSn register = 1000X110B
- ▲2: IICSn register = 1000X000B (WTIMn bit = 1<sup>Note 1</sup>)
- ▲3: IICSn register = 1000XX00B (WTIMn bit = 0<sup>Note 2</sup>)
- ▲4: IICSn register = 1000X110B
- ▲5: IICSn register = 1000X000B (WTIMn bit = 1<sup>Note 3</sup>)
- ▲6: IICSn register = 1000XX00B
- Δ7: IICSn register = 00000001B

- Notes**
1. Set the WTIMn bit (1) and change the timing of generating the interrupt request signal (INTIICn) to generate the start condition.
  2. Clear the WTIMn bit (0) to restore the original setting.
  3. Set the WTIMn bit (1) and change the timing of generating the interrupt request signal (INTIICn) to generate the stop condition.

**Remarks 1. ▲:** Always generated

- Δ: Generated only when SPIEn bit = 1
- X: don't care

2. Only  $\mu$ PD70F3931 (V850E/SJ3-H), 70F3932 (V850E/SJ3-H), and 70F3933 (V850E/SJ3-H): n = 0 to 3  
Other than  $\mu$ PD70F3931 (V850E/SJ3-H), 70F3932 (V850E/SJ3-H), and 70F3933 (V850E/SJ3-H): n = 0 to 5

<R>

<2> When WTIMn bit = 1

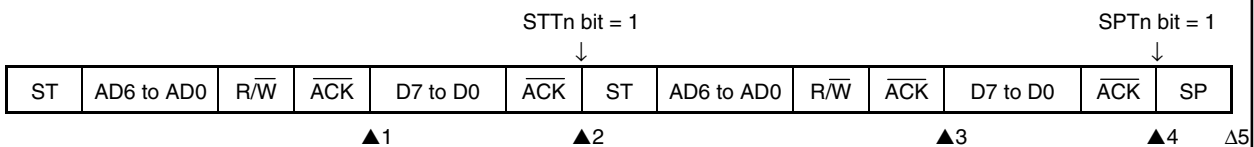

- ▲1: IICSn register = 1000X110B
- ▲2: IICSn register = 1000XX00B
- ▲3: IICSn register = 1000X110B
- ▲4: IICSn register = 1000XX00B
- Δ5: IICSn register = 00000001B

**Remarks 1. ▲:** Always generated

- Δ: Generated only when SPIEn bit = 1
- X: don't care

2. Only  $\mu$ PD70F3931 (V850E/SJ3-H), 70F3932 (V850E/SJ3-H), and 70F3933 (V850E/SJ3-H): n = 0 to 3  
Other than  $\mu$ PD70F3931 (V850E/SJ3-H), 70F3932 (V850E/SJ3-H), and 70F3933 (V850E/SJ3-H): n = 0 to 5

<R>



(3) Start ~ Code ~ Data ~ Data ~ Stop (extension code transmission)

<1> When WTIMn bit = 0

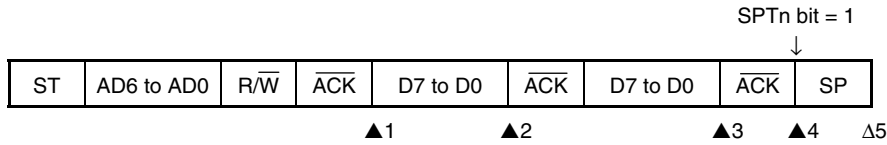

- ▲1: IICSn register = 1010X110B
- ▲2: IICSn register = 1010X000B
- ▲3: IICSn register = 1010X000B (WTIMn bit = 1<sup>Note</sup>)
- ▲4: IICSn register = 1010XX00B
- Δ5: IICSn register = 00000001B

**Note** Set the WTIMn bit (1) and change the timing of generating the interrupt request signal (INTIICn) to generate the stop condition.

- Remarks 1.** ▲: Always generated  
 Δ: Generated only when SPIEn bit = 1  
 X: don't care
2. Only  $\mu$ PD70F3931 (V850E/SJ3-H), 70F3932 (V850E/SJ3-H), and 70F3933 (V850E/SJ3-H): n = 0 to 3  
 Other than  $\mu$ PD70F3931 (V850E/SJ3-H), 70F3932 (V850E/SJ3-H), and 70F3933 (V850E/SJ3-H): n = 0 to 5

<R>

<2> When WTIMn bit = 1

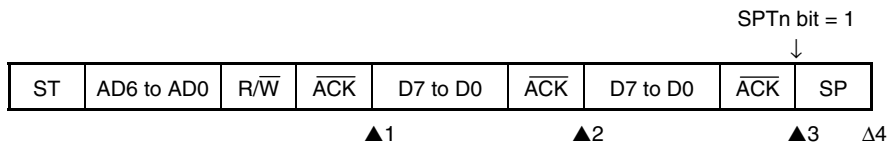

- ▲1: IICSn register = 1010X110B
- ▲2: IICSn register = 1010X100B
- ▲3: IICSn register = 1010XX00B
- Δ4: IICSn register = 00000001B

- Remarks 1.** ▲: Always generated  
 Δ: Generated only when SPIEn bit = 1  
 X: don't care
2. Only  $\mu$ PD70F3931 (V850E/SJ3-H), 70F3932 (V850E/SJ3-H), and 70F3933 (V850E/SJ3-H): n = 0 to 3  
 Other than  $\mu$ PD70F3931 (V850E/SJ3-H), 70F3932 (V850E/SJ3-H), and 70F3933 (V850E/SJ3-H): n = 0 to 5

<R>

19.7.2 Slave device operation (when receiving slave address (address match))

(1) Start ~ Address ~ Data ~ Data ~ Stop

<1> When IICn.WTIMn bit = 0

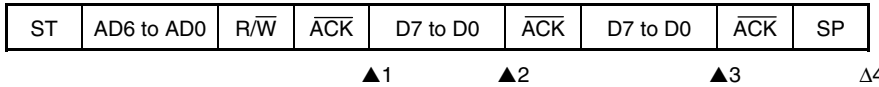

▲1: IICSn register = 0001X110B

▲2: IICSn register = 0001X000B

▲3: IICSn register = 0001X000B

Δ 4: IICSn register = 00000001B

**Remarks 1.** ▲: Always generated

Δ: Generated only when IICn.SPIEn bit = 1

X: don't care

2. Only μPD70F3931 (V850E/SJ3-H), 70F3932 (V850E/SJ3-H), and 70F3933 (V850E/SJ3-H): n = 0 to 3

Other than μPD70F3931 (V850E/SJ3-H), 70F3932 (V850E/SJ3-H), and 70F3933 (V850E/SJ3-H): n = 0 to 5

<R>

<2> When WTIMn bit = 1

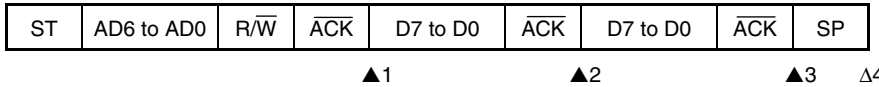

▲1: IICSn register = 0001X110B

▲2: IICSn register = 0001X100B

▲3: IICSn register = 0001XX00B

Δ 4: IICSn register = 00000001B

**Remarks 1.** ▲: Always generated

Δ: Generated only when SPIEn bit = 1

X: don't care

2. Only μPD70F3931 (V850E/SJ3-H), 70F3932 (V850E/SJ3-H), and 70F3933 (V850E/SJ3-H): n = 0 to 3

Other than μPD70F3931 (V850E/SJ3-H), 70F3932 (V850E/SJ3-H), and 70F3933 (V850E/SJ3-H): n = 0 to 5

<R>





(4) Start ~ Address ~ Data ~ Start ~ Address ~ Data ~ Stop

<1> When WTIMn bit = 0 (after restart, address mismatch (= not extension code))

ST	AD6 to AD0	R/W	ACK	D7 to D0	ACK	ST	AD6 to AD0	R/W	ACK	D7 to D0	ACK	SP
----	------------	-----	-----	----------	-----	----	------------	-----	-----	----------	-----	----

▲1

▲2

▲3

Δ4

▲1: IICSn register = 0001X110B

▲2: IICSn register = 0001X000B

▲3: IICSn register = 00000110B

Δ 4: IICSn register = 00000001B

**Remarks 1. ▲:** Always generated

Δ: Generated only when SPIEn bit = 1

X: don't care

**2. Only μPD70F3931 (V850E/SJ3-H), 70F3932 (V850E/SJ3-H), and 70F3933**

(V850E/SJ3-H): n = 0 to 3

Other than μPD70F3931 (V850E/SJ3-H), 70F3932 (V850E/SJ3-H), and 70F3933

(V850E/SJ3-H): n = 0 to 5

<R>

<2> When WTIMn bit = 1 (after restart, address mismatch (= not extension code))

ST	AD6 to AD0	R/W	ACK	D7 to D0	ACK	ST	AD6 to AD0	R/W	ACK	D7 to D0	ACK	SP
----	------------	-----	-----	----------	-----	----	------------	-----	-----	----------	-----	----

▲1

▲2

▲3

Δ4

▲1: IICSn register = 0001X110B

▲2: IICSn register = 0001XX00B

▲3: IICSn register = 00000110B

Δ 4: IICSn register = 00000001B

**Remarks 1. ▲:** Always generated

Δ: Generated only when SPIEn bit = 1

X: don't care

**2. Only μPD70F3931 (V850E/SJ3-H), 70F3932 (V850E/SJ3-H), and 70F3933**

(V850E/SJ3-H): n = 0 to 3

Other than μPD70F3931 (V850E/SJ3-H), 70F3932 (V850E/SJ3-H), and 70F3933

(V850E/SJ3-H): n = 0 to 5

<R>

### 19.7.3 Slave device operation (when receiving extension code)

Always under communication when receiving the extension code.

#### (1) Start ~ Code ~ Data ~ Data ~ Stop

##### <1> When IICn.WTIMn bit = 0

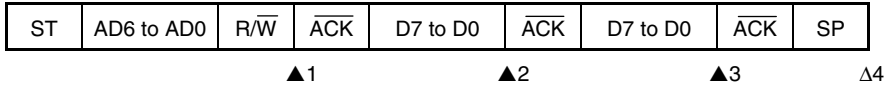

▲1: IICSn register = 0010X010B

▲2: IICSn register = 0010X000B

▲3: IICSn register = 0010X000B

Δ4: IICSn register = 00000001B

**Remarks 1.** ▲: Always generated

Δ: Generated only when IICn.SPIEn bit = 1

X: don't care

2. Only  $\mu$ PD70F3931 (V850E/SJ3-H), 70F3932 (V850E/SJ3-H), and 70F3933 (V850E/SJ3-H): n = 0 to 3

Other than  $\mu$ PD70F3931 (V850E/SJ3-H), 70F3932 (V850E/SJ3-H), and 70F3933 (V850E/SJ3-H): n = 0 to 5

##### <2> When WTIMn bit = 1

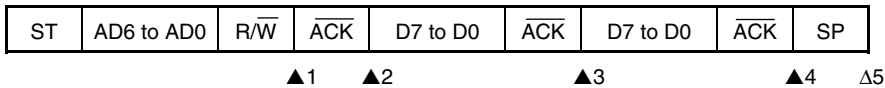

▲1: IICSn register = 0010X010B

▲2: IICSn register = 0010X110B

▲3: IICSn register = 0010X100B

▲4: IICSn register = 0010XX00B

Δ5: IICSn register = 00000001B

**Remarks 1.** ▲: Always generated

Δ: Generated only when SPIEn bit = 1

X: don't care

2. Only  $\mu$ PD70F3931 (V850E/SJ3-H), 70F3932 (V850E/SJ3-H), and 70F3933 (V850E/SJ3-H): n = 0 to 3

Other than  $\mu$ PD70F3931 (V850E/SJ3-H), 70F3932 (V850E/SJ3-H), and 70F3933 (V850E/SJ3-H): n = 0 to 5

## (2) Start ~ Code ~ Data ~ Start ~ Address ~ Data ~ Stop

## &lt;1&gt; When WTIMn bit = 0 (after restart, address match)

ST	AD6 to AD0	R/W	ACK	D7 to D0	ACK	ST	AD6 to AD0	R/W	ACK	D7 to D0	ACK	SP
----	------------	-----	-----	----------	-----	----	------------	-----	-----	----------	-----	----

▲1

▲2

▲3

▲4

Δ5

▲1: IICSn register = 0010X010B

▲2: IICSn register = 0010X000B

▲3: IICSn register = 0001X110B

▲4: IICSn register = 0001X000B

Δ5: IICSn register = 00000001B

**Remarks 1.** ▲: Always generated

Δ: Generated only when SPIEn bit = 1

X: don't care

**2.** Only  $\mu$ PD70F3931 (V850E/SJ3-H), 70F3932 (V850E/SJ3-H), and 70F3933

(V850E/SJ3-H): n = 0 to 3

Other than  $\mu$ PD70F3931 (V850E/SJ3-H), 70F3932 (V850E/SJ3-H), and 70F3933

(V850E/SJ3-H): n = 0 to 5

&lt;R&gt;

## &lt;2&gt; When WTIMn bit = 1 (after restart, address match)

ST	AD6 to AD0	R/W	ACK	D7 to D0	ACK	ST	AD6 to AD0	R/W	ACK	D7 to D0	ACK	SP
----	------------	-----	-----	----------	-----	----	------------	-----	-----	----------	-----	----

▲1

▲2

▲3

▲4

▲5

Δ6

▲1: IICSn register = 0010X010B

▲2: IICSn register = 0010X110B

▲3: IICSn register = 0010XX00B

▲4: IICSn register = 0001X110B

▲5: IICSn register = 0001XX00B

Δ6: IICSn register = 00000001B

**Remarks 1.** ▲: Always generated

Δ: Generated only when SPIEn bit = 1

X: don't care

**2.** Only  $\mu$ PD70F3931 (V850E/SJ3-H), 70F3932 (V850E/SJ3-H), and 70F3933

(V850E/SJ3-H): n = 0 to 3

Other than  $\mu$ PD70F3931 (V850E/SJ3-H), 70F3932 (V850E/SJ3-H), and 70F3933

(V850E/SJ3-H): n = 0 to 5

&lt;R&gt;

(3) Start ~ Code ~ Data ~ Start ~ Code ~ Data ~ Stop

<1> When WTIMn bit = 0 (after restart, extension code reception)

ST	AD6 to AD0	R/W	ACK	D7 to D0	ACK	ST	AD6 to AD0	R/W	ACK	D7 to D0	ACK	SP
----	------------	-----	-----	----------	-----	----	------------	-----	-----	----------	-----	----

▲1                      ▲2                                      ▲3                                      ▲4                                      Δ5

- ▲1: IICSn register = 0010X010B
- ▲2: IICSn register = 0010X000B
- ▲3: IICSn register = 0010X010B
- ▲4: IICSn register = 0010X000B
- Δ 5: IICSn register = 00000001B

**Remarks 1.** ▲: Always generated

- Δ: Generated only when SPIEn bit = 1
- X: don't care

2. Only  $\mu$ PD70F3931 (V850E/SJ3-H), 70F3932 (V850E/SJ3-H), and 70F3933 (V850E/SJ3-H): n = 0 to 3  
 Other than  $\mu$ PD70F3931 (V850E/SJ3-H), 70F3932 (V850E/SJ3-H), and 70F3933 (V850E/SJ3-H): n = 0 to 5

<R>

<2> When WTIMn bit = 1 (after restart, extension code reception)

ST	AD6 to AD0	R/W	ACK	D7 to D0	ACK	ST	AD6 to AD0	R/W	ACK	D7 to D0	ACK	SP
----	------------	-----	-----	----------	-----	----	------------	-----	-----	----------	-----	----

▲1    ▲2                                      ▲3                                      ▲4    ▲5                                      ▲6    Δ7

- ▲1: IICSn register = 0010X010B
- ▲2: IICSn register = 0010X110B
- ▲3: IICSn register = 0010XX00B
- ▲4: IICSn register = 0010X010B
- ▲5: IICSn register = 0010X110B
- ▲6: IICSn register = 0010XX00B
- Δ 7: IICSn register = 00000001B

**Remarks 1.** ▲: Always generated

- Δ: Generated only when SPIEn bit = 1
- X: don't care

2. Only  $\mu$ PD70F3931 (V850E/SJ3-H), 70F3932 (V850E/SJ3-H), and 70F3933 (V850E/SJ3-H): n = 0 to 3  
 Other than  $\mu$ PD70F3931 (V850E/SJ3-H), 70F3932 (V850E/SJ3-H), and 70F3933 (V850E/SJ3-H): n = 0 to 5

<R>



(4) Start ~ Code ~ Data ~ Start ~ Address ~ Data ~ Stop

<1> When WTIMn bit = 0 (after restart, address mismatch (= not extension code))

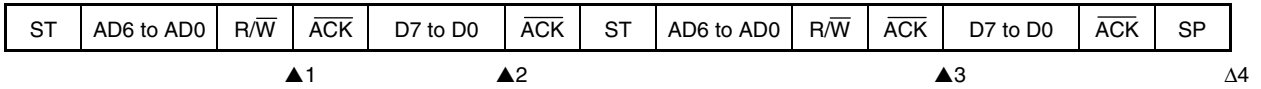

- ▲1: IICSn register = 0010X010B
- ▲2: IICSn register = 0010X000B
- ▲3: IICSn register = 00000110B
- Δ 4: IICSn register = 00000001B

- Remarks 1.** ▲: Always generated  
 Δ: Generated only when SPIEn bit = 1  
 X: don't care
- 2.** Only μPD70F3931 (V850E/SJ3-H), 70F3932 (V850E/SJ3-H), and 70F3933 (V850E/SJ3-H): n = 0 to 3  
 Other than μPD70F3931 (V850E/SJ3-H), 70F3932 (V850E/SJ3-H), and 70F3933 (V850E/SJ3-H): n = 0 to 5

<R>

<2> When WTIMn bit = 1 (after restart, address mismatch (= not extension code))

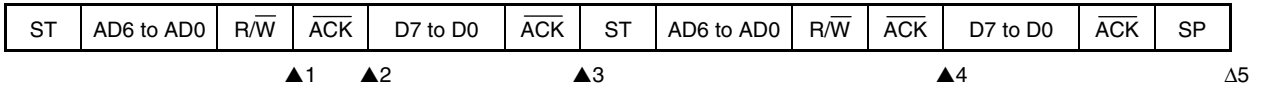

- ▲1: IICSn register = 0010X010B
- ▲2: IICSn register = 0010X110B
- ▲3: IICSn register = 0010XX00B
- ▲4: IICSn register = 00000110B
- Δ 5: IICSn register = 00000001B

- Remarks 1.** ▲: Always generated  
 Δ: Generated only when SPIEn bit = 1  
 X: don't care
- 2.** Only μPD70F3931 (V850E/SJ3-H), 70F3932 (V850E/SJ3-H), and 70F3933 (V850E/SJ3-H): n = 0 to 3  
 Other than μPD70F3931 (V850E/SJ3-H), 70F3932 (V850E/SJ3-H), and 70F3933 (V850E/SJ3-H): n = 0 to 5

<R>

## 19.7.4 Operation without communication

## (1) Start ~ Code ~ Data ~ Data ~ Stop

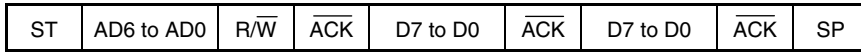

Δ1

Δ 1: IICSn register = 00000001B

**Remarks 1.** Δ: Generated only when SPIEn bit = 1

**2.** Only  $\mu$ PD70F3931 (V850E/SJ3-H), 70F3932 (V850E/SJ3-H), and 70F3933 (V850E/SJ3-H): n = 0 to 3

Other than  $\mu$ PD70F3931 (V850E/SJ3-H), 70F3932 (V850E/SJ3-H), and 70F3933 (V850E/SJ3-H): n = 0 to 5

&lt;R&gt;

**19.7.5 Arbitration loss operation (operation as slave after arbitration loss)**

When the device is used as the master in a multi-master system, read the IICSn.MSTS<sub>n</sub> bit to check the arbitration result each time the INTIIC<sub>n</sub> interrupt has been generated.

**(1) When arbitration loss occurs during transmission of slave address data**

**<1> When IICn.WTIMn bit = 0**

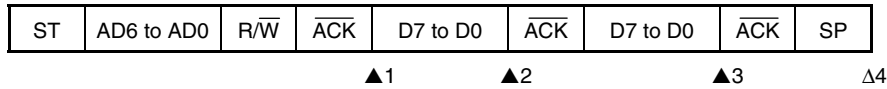

- ▲1: IIC<sub>n</sub> register = 0101X110B
- ▲2: IIC<sub>n</sub> register = 0001X000B
- ▲3: IIC<sub>n</sub> register = 0001X000B
- Δ 4: IIC<sub>n</sub> register = 00000001B

**Remarks 1. ▲:** Always generated

Δ: Generated only when IIC<sub>n</sub>.SPIEn bit = 1

X: don't care

**2.** Only μPD70F3931 (V850E/SJ3-H), 70F3932 (V850E/SJ3-H), and 70F3933 (V850E/SJ3-H): n = 0 to 3

Other than μPD70F3931 (V850E/SJ3-H), 70F3932 (V850E/SJ3-H), and 70F3933 (V850E/SJ3-H): n = 0 to 5

<R>

**<2> When WTIMn bit = 1**

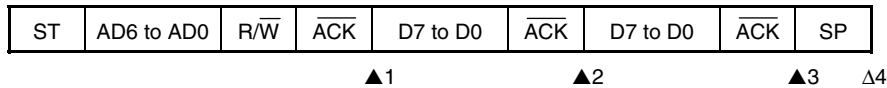

- ▲1: IIC<sub>n</sub> register = 0101X110B
- ▲2: IIC<sub>n</sub> register = 0001X100B
- ▲3: IIC<sub>n</sub> register = 0001XX00B
- Δ 4: IIC<sub>n</sub> register = 00000001B

**Remarks 1. ▲:** Always generated

Δ: Generated only when SPIEn bit = 1

X: don't care

**2.** Only μPD70F3931 (V850E/SJ3-H), 70F3932 (V850E/SJ3-H), and 70F3933 (V850E/SJ3-H): n = 0 to 3

Other than μPD70F3931 (V850E/SJ3-H), 70F3932 (V850E/SJ3-H), and 70F3933 (V850E/SJ3-H): n = 0 to 5

<R>

(2) When arbitration loss occurs during transmission of extension code

<1> When WTIMn bit = 0

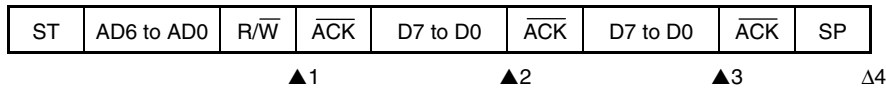

- ▲1: IICSn register = 0110X010B
- ▲2: IICSn register = 0010X000B
- ▲3: IICSn register = 0010X000B
- Δ 4: IICSn register = 00000001B

**Remarks 1.** ▲: Always generated

- Δ: Generated only when SPIEn bit = 1
- X: don't care

2. Only  $\mu$ PD70F3931 (V850E/SJ3-H), 70F3932 (V850E/SJ3-H), and 70F3933 (V850E/SJ3-H): n = 0 to 3  
 Other than  $\mu$ PD70F3931 (V850E/SJ3-H), 70F3932 (V850E/SJ3-H), and 70F3933 (V850E/SJ3-H): n = 0 to 5

<R>

<2> When WTIMn bit = 1

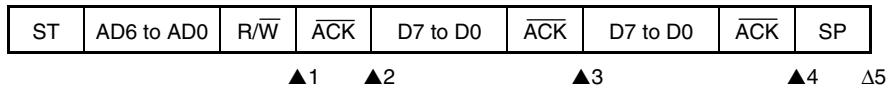

- ▲1: IICSn register = 0110X010B
- ▲2: IICSn register = 0010X110B
- ▲3: IICSn register = 0010X100B
- ▲4: IICSn register = 0010XX00B
- Δ 5: IICSn register = 00000001B

**Remarks 1.** ▲: Always generated

- Δ: Generated only when SPIEn bit = 1
- X: don't care

2. Only  $\mu$ PD70F3931 (V850E/SJ3-H), 70F3932 (V850E/SJ3-H), and 70F3933 (V850E/SJ3-H): n = 0 to 3  
 Other than  $\mu$ PD70F3931 (V850E/SJ3-H), 70F3932 (V850E/SJ3-H), and 70F3933 (V850E/SJ3-H): n = 0 to 5

<R>

**19.7.6 Operation when arbitration loss occurs (no communication after arbitration loss)**

When the device is used as the master in a multi-master system, read the IICS<sub>n</sub>.MSTS<sub>n</sub> bit to check the arbitration result each time the INTIIC<sub>n</sub> interrupt has been generated.

**(1) When arbitration loss occurs during transmission of slave address data**

ST	AD6 to AD0	R/W	ACK	D7 to D0	ACK	D7 to D0	ACK	SP
----	------------	-----	-----	----------	-----	----------	-----	----

▲1 Δ2

▲1: IICS<sub>n</sub> register = 01000110B  
 Δ2: IICS<sub>n</sub> register = 00000001B

**Remarks 1.** ▲: Always generated  
 Δ: Generated only when IIC<sub>Cn</sub>.SPIEn bit = 1

**2.** Only μPD70F3931 (V850E/SJ3-H), 70F3932 (V850E/SJ3-H), and 70F3933 (V850E/SJ3-H): n = 0 to 3  
 Other than μPD70F3931 (V850E/SJ3-H), 70F3932 (V850E/SJ3-H), and 70F3933 (V850E/SJ3-H): n = 0 to 5

<R>

**(2) When arbitration loss occurs during transmission of extension code**

ST	AD6 to AD0	R/W	ACK	D7 to D0	ACK	D7 to D0	ACK	SP
----	------------	-----	-----	----------	-----	----------	-----	----

▲1 Δ2

▲1: IICS<sub>n</sub> register = 0110X010B  
 IIC<sub>Cn</sub>.LRELn bit is set to 1 by software  
 Δ2: IICS<sub>n</sub> register = 00000001B

**Remarks 1.** ▲: Always generated  
 Δ: Generated only when SPIEn bit = 1  
 X: don't care

**2.** Only μPD70F3931 (V850E/SJ3-H), 70F3932 (V850E/SJ3-H), and 70F3933 (V850E/SJ3-H): n = 0 to 3  
 Other than μPD70F3931 (V850E/SJ3-H), 70F3932 (V850E/SJ3-H), and 70F3933 (V850E/SJ3-H): n = 0 to 5

<R>

## (3) When arbitration loss occurs during data transfer

## &lt;1&gt; When IICSn.WTIMn bit = 0

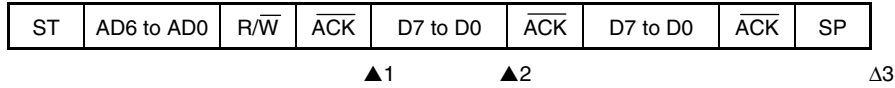

▲1: IICSn register = 10001110B

▲2: IICSn register = 01000000B

Δ3: IICSn register = 00000001B

**Remarks 1.** ▲: Always generated

Δ: Generated only when SPIEn bit = 1

2. Only  $\mu$ PD70F3931 (V850E/SJ3-H), 70F3932 (V850E/SJ3-H), and 70F3933 (V850E/SJ3-H): n = 0 to 3

Other than  $\mu$ PD70F3931 (V850E/SJ3-H), 70F3932 (V850E/SJ3-H), and 70F3933 (V850E/SJ3-H): n = 0 to 5

## &lt;2&gt; When WTIMn bit = 1

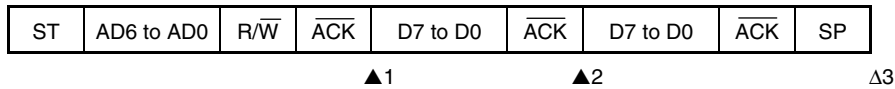

▲1: IICSn register = 10001110B

▲2: IICSn register = 01000100B

Δ3: IICSn register = 00000001B

**Remarks 1.** ▲: Always generated

Δ: Generated only when SPIEn bit = 1

2. Only  $\mu$ PD70F3931 (V850E/SJ3-H), 70F3932 (V850E/SJ3-H), and 70F3933 (V850E/SJ3-H): n = 0 to 3

Other than  $\mu$ PD70F3931 (V850E/SJ3-H), 70F3932 (V850E/SJ3-H), and 70F3933 (V850E/SJ3-H): n = 0 to 5

(4) When arbitration loss occurs due to restart condition during data transfer

<1> Not extension code (Example: Address mismatch)

ST	AD6 to AD0	R/W	ACK	D7 to Dn	ST	AD6 to AD0	R/W	ACK	D7 to D0	ACK	SP
----	------------	-----	-----	----------	----	------------	-----	-----	----------	-----	----

▲1

▲2

Δ3

▲1: IICSn register = 1000X110B

▲2: IICSn register = 01000110B

Δ 3: IICSn register = 00000001B

**Remarks 1. ▲:** Always generated

Δ: Generated only when SPIEn bit = 1

X: don't care

Dn = D6 to D0

**2.** Only μPD70F3931 (V850E/SJ3-H), 70F3932 (V850E/SJ3-H), and 70F3933

(V850E/SJ3-H): n = 0 to 3

Other than μPD70F3931 (V850E/SJ3-H), 70F3932 (V850E/SJ3-H), and 70F3933

(V850E/SJ3-H): n = 0 to 5

<R>

<2> Extension code

ST	AD6 to AD0	R/W	ACK	D7 to Dn	ST	AD6 to AD0	R/W	ACK	D7 to D0	ACK	SP
----	------------	-----	-----	----------	----	------------	-----	-----	----------	-----	----

▲1

▲2

Δ3

▲1: IICSn register = 1000X110B

▲2: IICSn register = 0110X010B

IICn.LRELn bit is set to 1 by software

Δ 3: IICSn register = 00000001B

**Remarks 1. ▲:** Always generated

Δ: Generated only when SPIEn bit = 1

X: don't care

Dn = D6 to D0

**2.** Only μPD70F3931 (V850E/SJ3-H), 70F3932 (V850E/SJ3-H), and 70F3933

(V850E/SJ3-H): n = 0 to 3

Other than μPD70F3931 (V850E/SJ3-H), 70F3932 (V850E/SJ3-H), and 70F3933

(V850E/SJ3-H): n = 0 to 5

<R>

## (5) When arbitration loss occurs due to stop condition during data transfer

ST	AD6 to AD0	R/W	ACK	D7 to Dn	SP
----	------------	-----	-----	----------	----

▲1

Δ2

▲1: IICSn register = 1000X110B

Δ2: IICSn register = 01000001B

**Remarks 1.** ▲: Always generated

Δ: Generated only when SPIEn bit = 1

X: don't care

Dn = D6 to D0

**2.** Only  $\mu$ PD70F3931 (V850E/SJ3-H), 70F3932 (V850E/SJ3-H), and 70F3933

(V850E/SJ3-H): n = 0 to 3

Other than  $\mu$ PD70F3931 (V850E/SJ3-H), 70F3932 (V850E/SJ3-H), and 70F3933

(V850E/SJ3-H): n = 0 to 5

&lt;R&gt;



(6) When arbitration loss occurs due to low level of SDA0n pin when attempting to generate a restart condition

<1> When WTIMn bit = 0

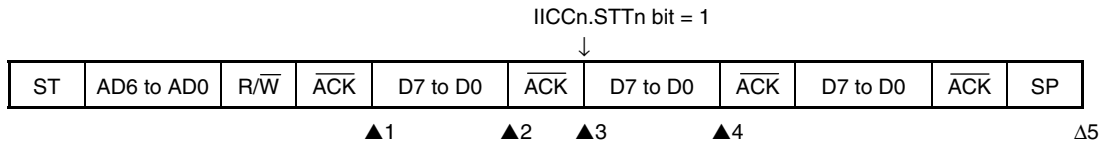

- ▲1: IICSn register = 1000X110B
- ▲2: IICSn register = 1000X000B (WTIMn bit = 1)
- ▲3: IICSn register = 1000X100B (WTIMn bit = 0)
- ▲4: IICSn register = 01000000B
- Δ5: IICSn register = 00000001B

**Remarks 1.** ▲: Always generated

Δ: Generated only when SPIEn bit = 1

X: don't care

2. Only  $\mu$ PD70F3931 (V850E/SJ3-H), 70F3932 (V850E/SJ3-H), and 70F3933 (V850E/SJ3-H): n = 0 to 3

Other than  $\mu$ PD70F3931 (V850E/SJ3-H), 70F3932 (V850E/SJ3-H), and 70F3933 (V850E/SJ3-H): n = 0 to 5

<R>

<2> When WTIMn bit = 1

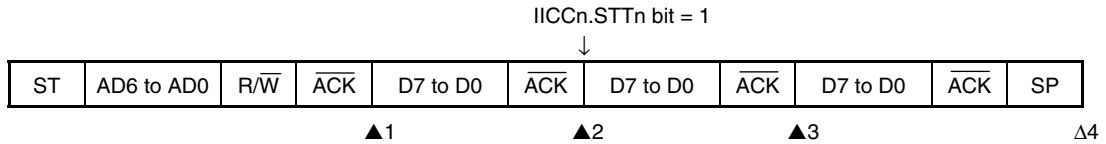

- ▲1: IICSn register = 1000X110B
- ▲2: IICSn register = 1000X100B
- ▲3: IICSn register = 01000100B
- Δ4: IICSn register = 00000001B

**Remarks 1.** ▲: Always generated

Δ: Generated only when SPIEn bit = 1

X: don't care

2. Only  $\mu$ PD70F3931 (V850E/SJ3-H), 70F3932 (V850E/SJ3-H), and 70F3933 (V850E/SJ3-H): n = 0 to 3

Other than  $\mu$ PD70F3931 (V850E/SJ3-H), 70F3932 (V850E/SJ3-H), and 70F3933 (V850E/SJ3-H): n = 0 to 5

<R>

(7) When arbitration loss occurs due to a stop condition when attempting to generate a restart condition

<1> When WTIMn bit = 0

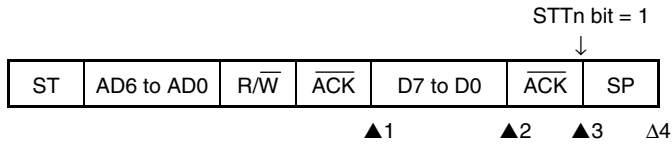

- ▲1: IICSn register = 1000X110B
- ▲2: IICSn register = 1000X000B (WTIMn bit = 1)
- ▲3: IICSn register = 1000XX00B
- Δ 4: IICSn register = 01000001B

**Remarks 1.** ▲: Always generated

Δ: Generated only when SPIEn bit = 1

X: don't care

2. Only  $\mu$ PD70F3931 (V850E/SJ3-H), 70F3932 (V850E/SJ3-H), and 70F3933 (V850E/SJ3-H): n = 0 to 3

Other than  $\mu$ PD70F3931 (V850E/SJ3-H), 70F3932 (V850E/SJ3-H), and 70F3933 (V850E/SJ3-H): n = 0 to 5

<R>

<2> When WTIMn bit = 1

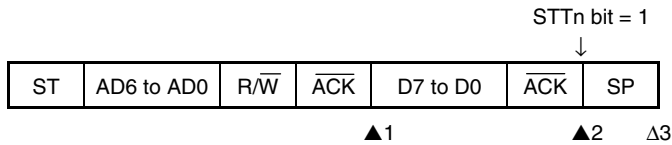

- ▲1: IICSn register = 1000X110B
- ▲2: IICSn register = 1000XX00B
- Δ 3: IICSn register = 01000001B

**Remarks 1.** ▲: Always generated

Δ: Generated only when SPIEn bit = 1

X: don't care

2. Only  $\mu$ PD70F3931 (V850E/SJ3-H), 70F3932 (V850E/SJ3-H), and 70F3933 (V850E/SJ3-H): n = 0 to 3

Other than  $\mu$ PD70F3931 (V850E/SJ3-H), 70F3932 (V850E/SJ3-H), and 70F3933 (V850E/SJ3-H): n = 0 to 5

<R>

(8) When arbitration loss occurs due to low level of SDA0n pin when attempting to generate a stop condition

<1> When WTIMn bit = 0

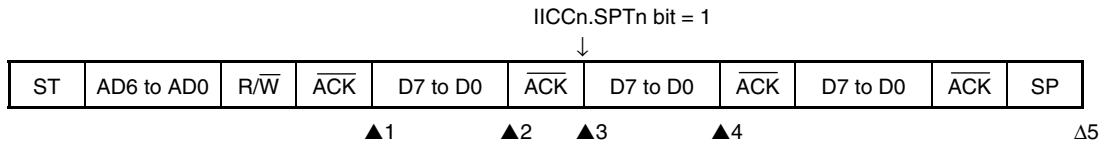

- ▲1: IICSn register = 1000X110B
- ▲2: IICSn register = 1000X000B (WTIMn bit = 1)
- ▲3: IICSn register = 1000X100B (WTIMn bit = 0)
- ▲4: IICSn register = 01000100B
- Δ 5: IICSn register = 00000001B

**Remarks 1.** ▲: Always generated

Δ: Generated only when SPIEn bit = 1

X: don't care

2. Only  $\mu$ PD70F3931 (V850E/SJ3-H), 70F3932 (V850E/SJ3-H), and 70F3933 (V850E/SJ3-H): n = 0 to 3

Other than  $\mu$ PD70F3931 (V850E/SJ3-H), 70F3932 (V850E/SJ3-H), and 70F3933 (V850E/SJ3-H): n = 0 to 5

<R>

<2> When WTIMn bit = 1

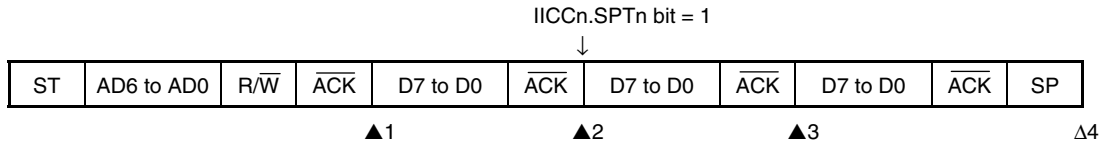

- ▲1: IICSn register = 1000X110B
- ▲2: IICSn register = 1000X100B
- ▲3: IICSn register = 01000100B
- Δ 4: IICSn register = 00000001B

**Remarks 1.** ▲: Always generated

Δ: Generated only when SPIEn bit = 1

X: don't care

2. Only  $\mu$ PD70F3931 (V850E/SJ3-H), 70F3932 (V850E/SJ3-H), and 70F3933 (V850E/SJ3-H): n = 0 to 3

Other than  $\mu$ PD70F3931 (V850E/SJ3-H), 70F3932 (V850E/SJ3-H), and 70F3933 (V850E/SJ3-H): n = 0 to 5

<R>

## 19.8 Interrupt Request Signal (INTIICn) Generation Timing and Wait Control

The setting of the IICn.WTIMn bit determines the timing by which the INTIICn register is generated and the corresponding wait control, as shown below.

**Table 19-6. INTIICn Generation Timing and Wait Control**

WTIMn Bit	During Slave Device Operation			During Master Device Operation		
	Address	Data Reception	Data Transmission	Address	Data Reception	Data Transmission
0	9 <sup>Notes 1, 2</sup>	8 <sup>Note 2</sup>	8 <sup>Note 2</sup>	9	8	8
1	9 <sup>Notes 1, 2</sup>	9 <sup>Note 2</sup>	9 <sup>Note 2</sup>	9	9	9

**Notes 1.** The slave device's INTIICn signal and wait period occur at the falling edge of the ninth clock only when there is a match with the address set to the SVAn register.

At this point,  $\overline{ACK}$  is generated regardless of the value set to the IICn.ACKEn bit. For a slave device that has received an extension code, the INTIICn signal occurs at the falling edge of the eighth clock.

When the address does not match after restart, the INTIICn signal is generated at the falling edge of the ninth clock, but no wait occurs.

- 2.** If the received address does not match the contents of the SVAn register and an extension code is not received, neither the INTIICn signal nor a wait state is generated.

**Remarks 1.** The numbers in the table indicate the number of the serial clock's clock signals. Interrupt requests and wait control are both synchronized with the falling edge of these clock signals.

- <R> **2.** Only  $\mu$ PD70F3931 (V850E/SJ3-H), 70F3932 (V850E/SJ3-H), and 70F3933 (V850E/SJ3-H): n = 0 to 3  
Other than  $\mu$ PD70F3931 (V850E/SJ3-H), 70F3932 (V850E/SJ3-H), and 70F3933 (V850E/SJ3-H): n = 0 to 5

### (1) During address transmission/reception

- Slave device operation: Interrupt and wait timing are determined depending on the conditions in Notes 1 and 2 above regardless of the WTIMn bit.
- Master device operation: Interrupt and wait timing occur at the falling edge of the ninth clock regardless of the WTIMn bit.

### (2) During data reception

- Master/slave device operation: Interrupt and wait timing is determined according to the WTIMn bit.

### (3) During data transmission

- Master/slave device operation: Interrupt and wait timing is determined according to the WTIMn bit.

**(4) Wait state cancellation method**

The four wait state cancellation methods are as follows.

- By writing data to the IICn register
- By setting the IICn.WRELn bit to 1 (wait cancellation)
- By setting the IICn.STTn bit to 1 (start condition generation)<sup>Note</sup>
- By setting the IICn.SPTn bit to 1 (stop condition generation)<sup>Note</sup>

**Note** Master only

When an 8-clock wait has been selected (WTIMn bit = 0), whether or not  $\overline{\text{ACK}}$  has been generated must be determined prior to wait cancellation.

**(5) Stop condition detection**

The INTIICn signal is generated when a stop condition is detected.

**19.9 Address Match Detection Method**

In I<sup>2</sup>C bus mode, the master device can select a particular slave device by transmitting the corresponding slave address.

Address match detection is performed automatically by hardware. The INTIICn signal occurs when a local address has been set to the SVAn register and when the address set to the SVAn register matches the slave address sent by the master device, or when an extension code has been received.

<R> **Remark** Only  $\mu$ PD70F3931 (V850E/SJ3-H), 70F3932 (V850E/SJ3-H), and 70F3933 (V850E/SJ3-H): n = 0 to 3  
Other than  $\mu$ PD70F3931 (V850E/SJ3-H), 70F3932 (V850E/SJ3-H), and 70F3933 (V850E/SJ3-H): n = 0 to 5

**19.10 Error Detection**

In I<sup>2</sup>C bus mode, the status of the serial data bus pin (SDA0n) during data transmission is captured by the IICn register of the transmitting device, so the data of the IICn register prior to transmission can be compared with the transmitted IICn data to enable detection of transmission errors. A transmission error is judged as having occurred when the compared data values do not match.

<R> **Remark** Only  $\mu$ PD70F3931 (V850E/SJ3-H), 70F3932 (V850E/SJ3-H), and 70F3933 (V850E/SJ3-H): n = 0 to 3  
Other than  $\mu$ PD70F3931 (V850E/SJ3-H), 70F3932 (V850E/SJ3-H), and 70F3933 (V850E/SJ3-H): n = 0 to 5

### 19.11 Extension Code

<R> **Remark** Only  $\mu$ PD70F3931 (V850E/SJ3-H), 70F3932 (V850E/SJ3-H), and 70F3933 (V850E/SJ3-H): n = 0 to 3  
 Other than  $\mu$ PD70F3931 (V850E/SJ3-H), 70F3932 (V850E/SJ3-H), and 70F3933 (V850E/SJ3-H): n = 0 to 5

(1) When the higher 4 bits of the receive address are either 0000 or 1111, the extension code flag (IICSn.EXCn bit) is set for extension code reception and an interrupt request signal (INTIICn) is issued at the falling edge of the eighth clock.  
 The local address stored in the SVAn register is not affected.

(2) If 11110xx0 is set to the SVAn register by a 10-bit address transfer and 11110xx0 is transferred from the master device, the results are as follows. Note that the INTIICn signal occurs at the falling edge of the eighth clock.

- Higher four bits of data match: EXCn bit = 1
- Seven bits of data match: IICSn.COIn bit = 1

(3) Since the processing after the interrupt request signal occurs differs according to the data that follows the extension code, such processing is performed by software.

The device participates in communication when it receives the extension code while it is operating as a slave, even if the address does not match.

For example, when operation as a slave is not desired after the extension code is received, set the IICSn.LRELn bit to 1 and the CPU will enter the next communication wait state.

**Table 19-7. Extension Code Bit Definitions**

Slave Address	R/W Bit	Description
0000 000	0	General call address
1111 0xx	0	10-bit slave address specification (upon address authentication)
1111 0xx	1	10-bit slave address specification (upon read command issuance after address matches)

**Remark** For the extension codes other than above, see the I<sup>2</sup>C bus specifications issued by NXP Semiconductors.

### 19.12 Arbitration

When several master devices simultaneously generate a start condition (when the IICn.STTn bit is set to 1 before the IICSn.STDn bit is set to 1), communication between the master devices is performed while the number of clocks is adjusted until the data differs. This kind of operation is called arbitration.

When one of the master devices loses in arbitration, an arbitration loss flag (IICSn.ALDn bit) is set to 1 via the timing by which the arbitration loss occurred, and the SCL0n and SDA0n lines are both set to high impedance, which releases the bus.

Arbitration loss is detected based on the timing of the next interrupt request signal (INTIICn) (the eighth or ninth clock, when a stop condition is detected, etc.) and the setting of the ALDn bit to 1, which is made by software.

For details of interrupt request timing, see **19.7 I<sup>2</sup>C Interrupt Request Signals (INTIICn)**.

**Figure 19-11. Arbitration Timing Example**

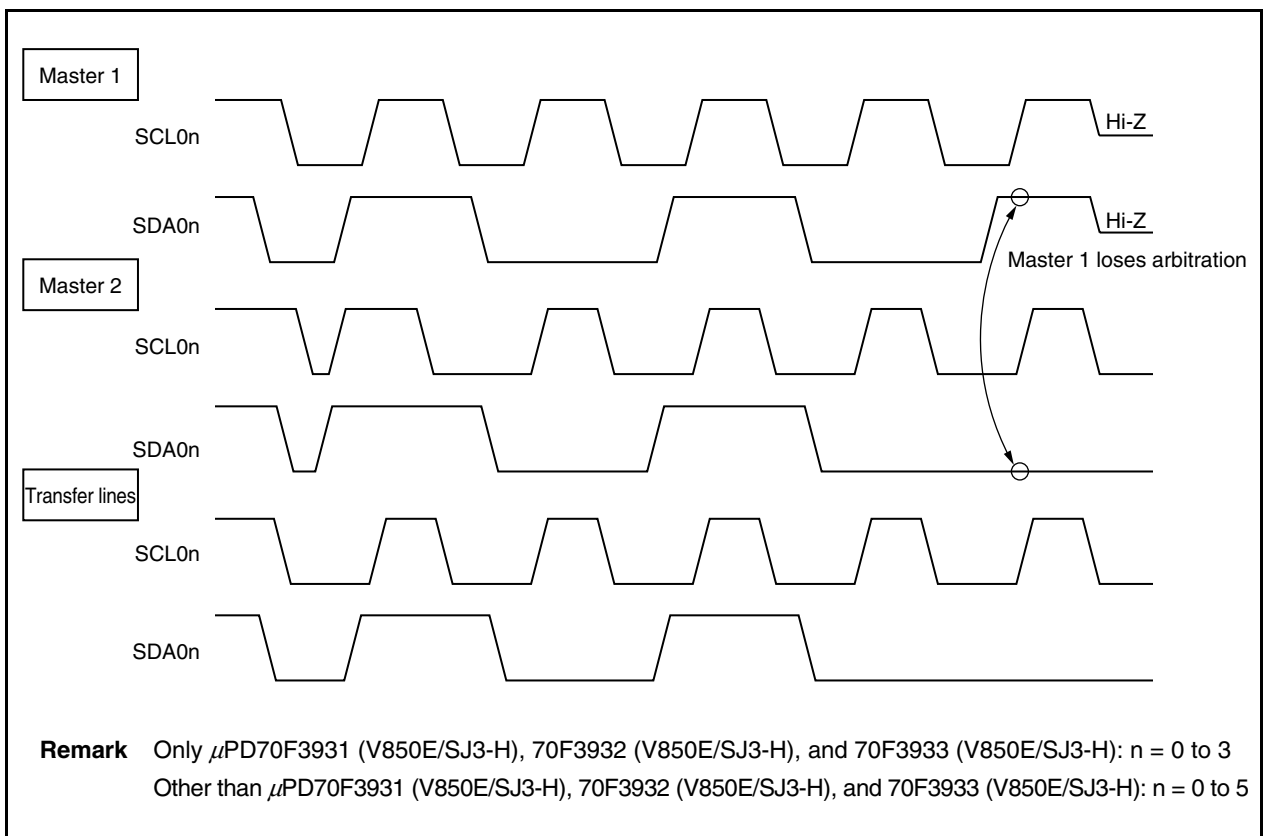

<R>

**Table 19-8. Status During Arbitration and Interrupt Request Signal Generation Timing**

Status During Arbitration	Interrupt Request Generation Timing
Transmitting address transmission	At falling edge of eighth or ninth clock following byte transfer <sup>Note 1</sup>
Read/write data after address transmission	
Transmitting extension code	
Read/write data after extension code transmission	
Transmitting data	
ACK transfer period after data reception	
When restart condition is detected during data transfer	
When stop condition is detected during data transfer	When stop condition is generated (when IICn.SPIEn bit = 1) <sup>Note 2</sup>
When SDA0n pin is low level while attempting to generate restart condition	At falling edge of eighth or ninth clock following byte transfer <sup>Note 1</sup>
When stop condition is detected while attempting to generate restart condition	When stop condition is generated (when IICn.SPIEn bit = 1) <sup>Note 2</sup>
When SDA0n pin is low level while attempting to generate stop condition	At falling edge of eighth or ninth clock following byte transfer <sup>Note 1</sup>
When SCL0n pin is low level while attempting to generate restart condition	

**Notes 1.** When the IICn.WTIMn bit = 1, an INTIICn signal occurs at the falling edge of the ninth clock. When the WTIMn bit = 0 and the extension code's slave address is received, an INTIICn signal occurs at the falling edge of the eighth clock.

**2.** When there is a possibility that arbitration will occur, set the SPIEn bit to 1 for master device operation.

<R> **Remark** Only  $\mu$ PD70F3931 (V850E/SJ3-H), 70F3932 (V850E/SJ3-H), and 70F3933 (V850E/SJ3-H): n = 0 to 3  
Other than  $\mu$ PD70F3931 (V850E/SJ3-H), 70F3932 (V850E/SJ3-H), and 70F3933 (V850E/SJ3-H): n = 0 to 5

### 19.13 Wakeup Function

The I<sup>2</sup>C bus slave function is a function that generates an interrupt request signal (INTIICn) when a local address and extension code have been received.

This function makes processing more efficient by preventing unnecessary the INTIICn signal from occurring when addresses do not match.

When a start condition is detected, wakeup standby mode is set. This wakeup standby mode is in effect while addresses are transmitted due to the possibility that an arbitration loss may change the master device (which has generated a start condition) to a slave device.

However, when a stop condition is detected, the IICn.SPIEn bit is set regardless of the wakeup function, and this determines whether INTIICn signal is enabled or disabled.

<R> **Remark** Only  $\mu$ PD70F3931 (V850E/SJ3-H), 70F3932 (V850E/SJ3-H), and 70F3933 (V850E/SJ3-H): n = 0 to 3  
Other than  $\mu$ PD70F3931 (V850E/SJ3-H), 70F3932 (V850E/SJ3-H), and 70F3933 (V850E/SJ3-H): n = 0 to 5



## 19.14 Communication Reservation

### 19.14.1 When communication reservation function is enabled (IICFn.IICRSVn bit = 0)

To start master device communications when not currently using the bus, a communication reservation can be made to enable transmission of a start condition when the bus is released. There are two modes in which the bus is not used.

- When arbitration results in neither master nor slave operation
- When an extension code is received and slave operation is disabled ( $\overline{\text{ACK}}$  is not returned and the bus was released when the IICFn.LRELn bit was set to 1).

If the IICFn.STTn bit is set to 1 while the bus is not used, a start condition is automatically generated and a wait state is set after the bus is released (after a stop condition is detected).

The device automatically starts communication as the master when an address is written to the IICn register after the IICFn.SPIEn bit has been set (1) and release of the bus has been detected (i.e., the stop condition has been detected) by generation of an interrupt request (INTIICn). Data written to the IICn register is invalid before the stop condition is detected.

When the STTn bit has been set to 1, the operation mode (as start condition or as communication reservation) is determined according to the bus status.

If the bus has been released ..... A start condition is generated

If the bus has not been released (standby mode) ..... Communication reservation

To detect which operation mode has been determined for the STTn bit, set the STTn bit to 1, wait for the wait period, then check the IICSn.MSTS bit.

The wait periods, which should be set via software, are listed in Table 19-9. These wait periods can be set by the SMCn, CLn1, and CLn0 bits of the IICCLn register and the IICXn.CLXn bit.

**Table 19-9. Wait Periods**

CLXn Bit	SMCn Bit	CLn1 Bit	CLn0 Bit	OCKSm Register	Wait Time
0	0	0	0	18H	23 clocks
0	0	0	0	10H	46 clocks
0	0	0	0	11H	69 clocks
0	0	0	0	12H	92 clocks
0	0	0	0	13H	115 clocks
0	0	0	1	18H	43 clocks
0	0	0	1	10H	86 clocks
0	0	0	1	11H	129 clocks
0	0	0	1	12H	172 clocks
0	0	0	1	13H	215 clocks
0	0	1	0	00H	43 clocks
0	0	1	1	18H	34 clocks <sup>Note</sup>
0	0	1	1	10H	68 clocks <sup>Note</sup>
0	0	1	1	11H	102 clocks <sup>Note</sup>
0	0	1	1	12H	136 clocks <sup>Note</sup>
0	0	1	1	13H	170 clocks <sup>Note</sup>
0	1	0	×	18H	15 clocks
0	1	0	×	10H	30 clocks
0	1	0	×	11H	45 clocks
0	1	0	×	12H	60 clocks
0	1	0	×	13H	75 clocks
0	1	1	0	00H	15 clocks
0	1	1	1	18H	12 clocks <sup>Note</sup>
0	1	1	1	10H	24 clocks <sup>Note</sup>
0	1	1	1	11H	36 clocks <sup>Note</sup>
0	1	1	1	12H	48 clocks <sup>Note</sup>
0	1	1	1	13H	60 clocks <sup>Note</sup>
1	1	0	×	18H	9 clocks
1	1	0	×	10H	18 clocks
1	1	0	×	11H	27 clocks
1	1	0	×	12H	36 clocks
1	1	0	×	13H	45 clocks
1	1	1	0	00H	9 clocks

**Note** Settings are prohibited for I<sup>2</sup>C04 and I<sup>2</sup>C05.

<R>

- Remarks**
1. Only  $\mu$ PD70F3931 (V850E/SJ3-H), 70F3932 (V850E/SJ3-H), and 70F3933 (V850E/SJ3-H): n = 0 to 3, m = 0, 1  
Other than  $\mu$ PD70F3931 (V850E/SJ3-H), 70F3932 (V850E/SJ3-H), and 70F3933 (V850E/SJ3-H): n = 0 to 5, m = 0, 1, 3
  2. × = Don't care
  3. Clock = f<sub>CPU</sub> (CPU clock frequency)

The communication reservation timing is shown below.

Figure 19-12. Communication Reservation Timing

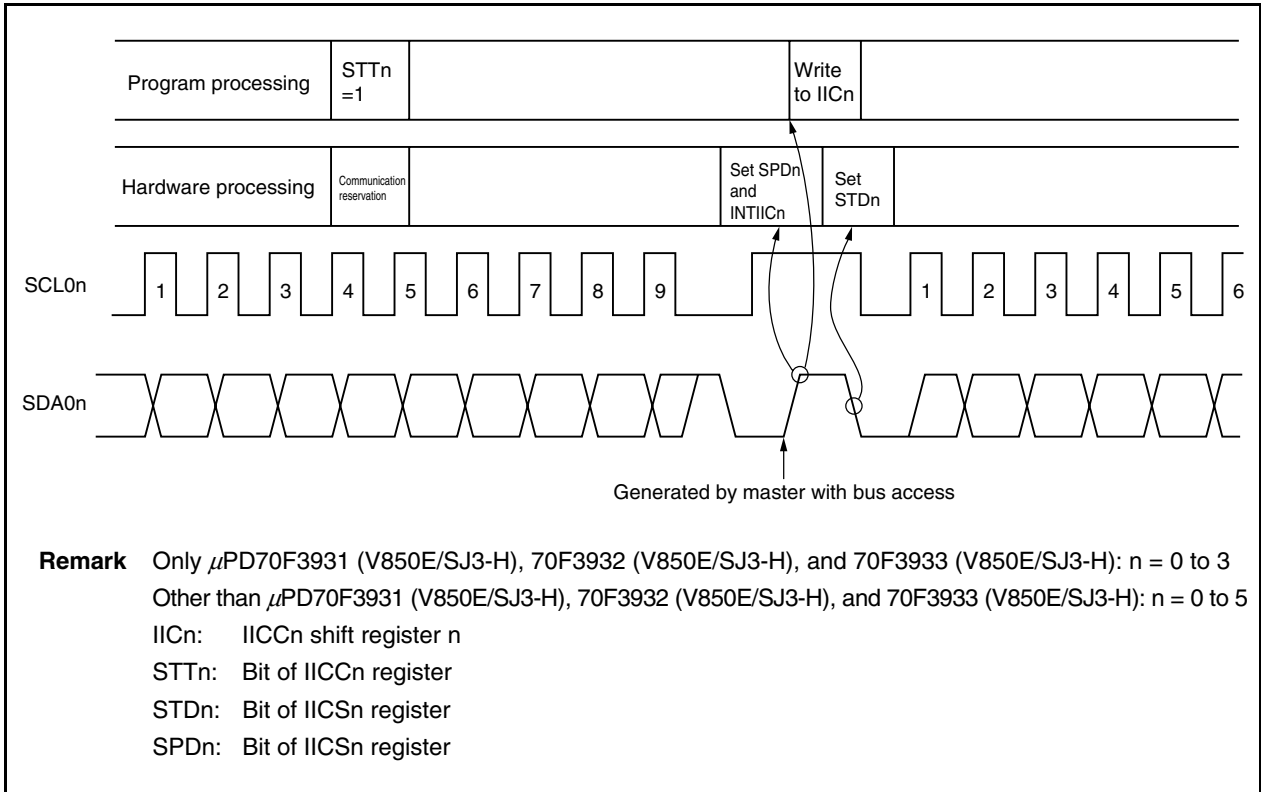

<R>

Communication reservations are accepted via the following timing. After the IICSn.STDn bit is set to 1, a communication reservation can be made by setting the IICn.STTn bit to 1 before a stop condition is detected (n = 0 to 5).

Figure 19-13. Timing for Accepting Communication Reservations

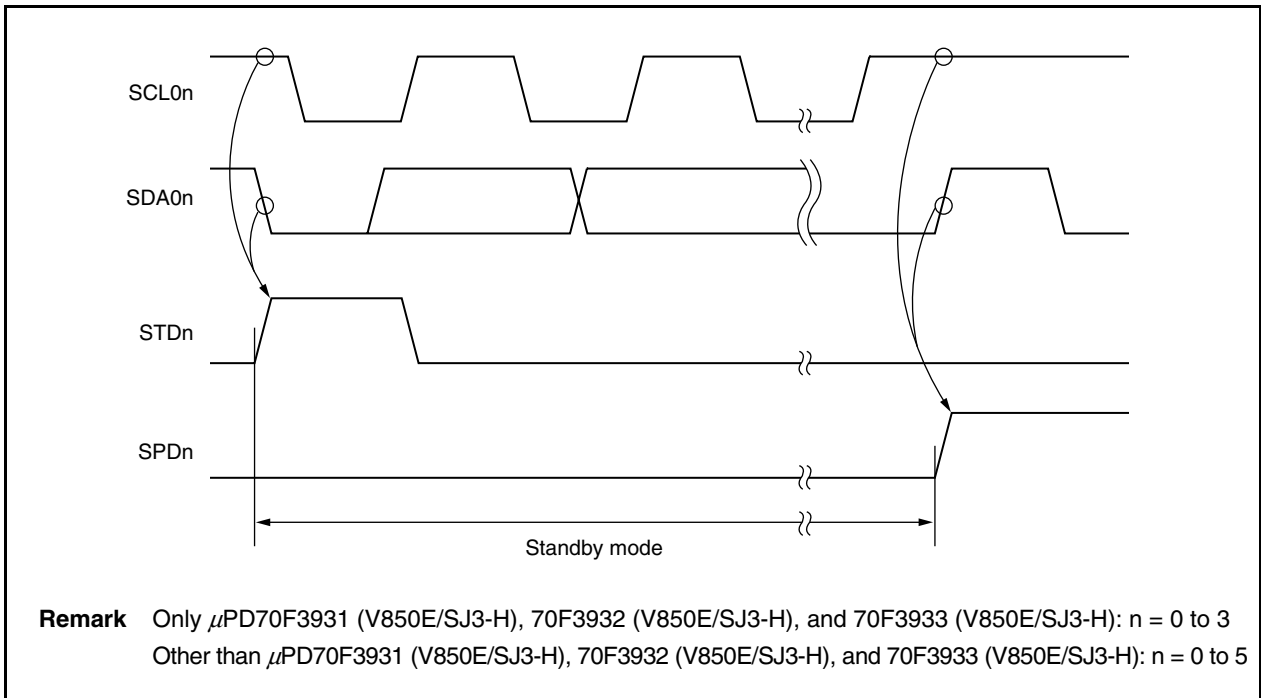

<R>

The communication reservation flowchart is illustrated below.

**Figure 19-14. Communication Reservation Flowchart**

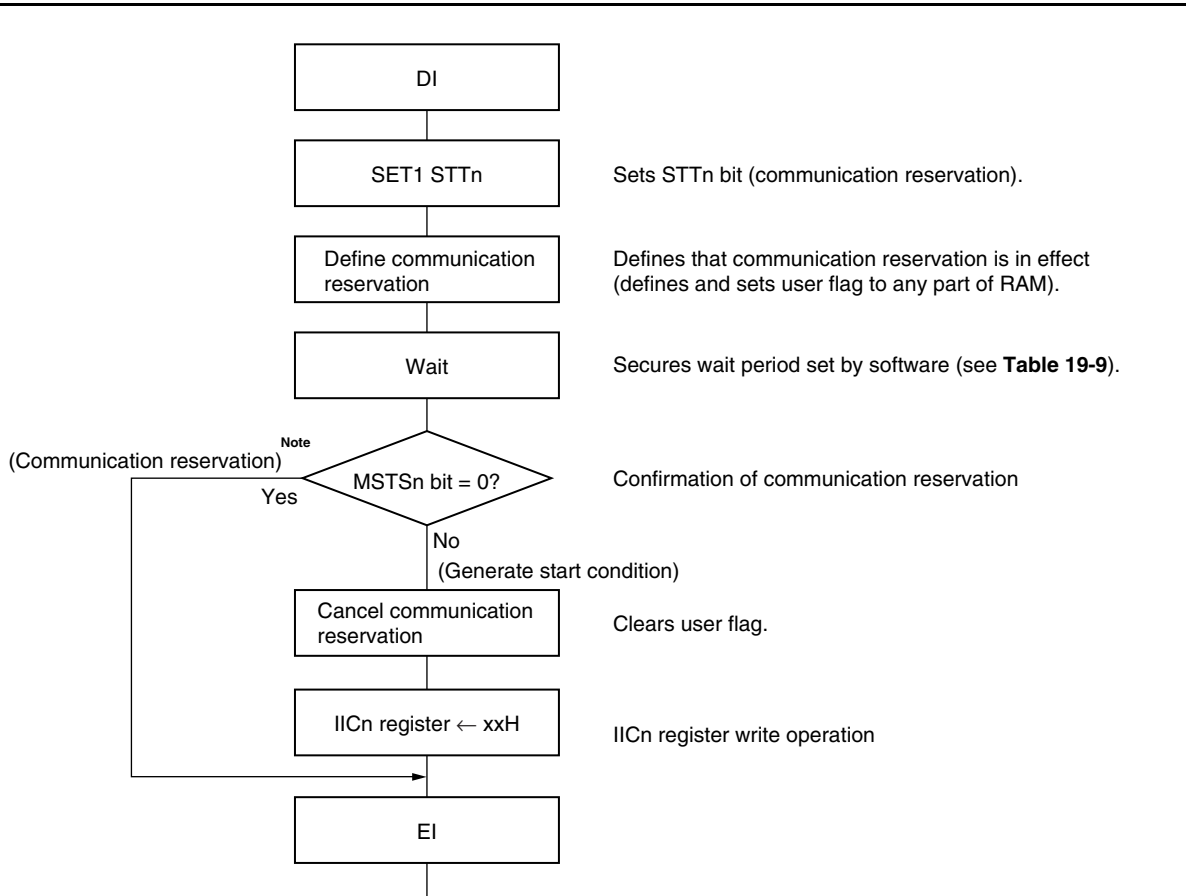

**Note** The communication reservation operation executes a write to the IICn register when a stop condition interrupt request occurs.

<R> **Remark** Only  $\mu$ PD70F3931 (V850E/SJ3-H), 70F3932 (V850E/SJ3-H), and 70F3933 (V850E/SJ3-H):  
 n = 0 to 3  
 Other than  $\mu$ PD70F3931 (V850E/SJ3-H), 70F3932 (V850E/SJ3-H), and 70F3933 (V850E/SJ3-H):  
 n = 0 to 5

**19.14.2 When communication reservation function is disabled (IICFn.IICRSVn bit = 1)**

When the IICFn.STTn bit is set when the bus is not used in a communication during bus communication, this request is rejected and a start condition is not generated. There are two modes in which the bus is not used.

- When arbitration results in neither master nor slave operation
- When an extension code is received and slave operation is disabled ( $\overline{\text{ACK}}$  is not returned and the bus was released when the IICFn.LRELn bit was set to 1).

To confirm whether the start condition was generated or request was rejected, check the IICFn.STCFn flag. The time shown in Table 19-10 is required until the STCFn flag is set after setting the STTn bit to 1. Therefore, secure the time by software.

**Table 19-10. Wait Periods**

CLn1 Bit	CLn0 Bit	OCKSm Register	Wait Time
0	×	18H	5 clocks
0	×	10H	10 clocks
0	×	11H	15 clocks
0	×	12H	20 clocks
0	×	13H	25 clocks
1	0	00H	5 clocks
1	1	18H	5 clocks <sup>Note</sup>
1	1	10H	10 clocks <sup>Note</sup>
1	1	11H	15 clocks <sup>Note</sup>
1	1	12H	20 clocks <sup>Note</sup>
1	1	13H	25 clocks <sup>Note</sup>

**Note** Settings are prohibited for I<sup>2</sup>C04 and I<sup>2</sup>C05.

<R>

- Remarks 1.** Only  $\mu$ PD70F3931 (V850E/SJ3-H), 70F3932 (V850E/SJ3-H), and 70F3933 (V850E/SJ3-H): n = 0 to 3, m = 0, 1  
Other than  $\mu$ PD70F3931 (V850E/SJ3-H), 70F3932 (V850E/SJ3-H), and 70F3933 (V850E/SJ3-H): n = 0 to 5, m = 0, 1, 3
- 2.** × = Don't care
- 3.** Clock = f<sub>CPU</sub> (CPU clock frequency)

## 19.15 Cautions

<R> **Remark** Only  $\mu$ PD70F3931 (V850E/SJ3-H), 70F3932 (V850E/SJ3-H), and 70F3933 (V850E/SJ3-H): n = 0 to 3  
Other than  $\mu$ PD70F3931 (V850E/SJ3-H), 70F3932 (V850E/SJ3-H), and 70F3933 (V850E/SJ3-H): n = 0 to 5

### (1) When IICFn.STCENn bit = 0

Immediately after the I<sup>2</sup>C0n operation is enabled, the bus communication status (IICFn.IICBSYn bit = 1) is recognized regardless of the actual bus status. To execute master communication in the status where a stop condition has not been detected, generate a stop condition and then release the bus before starting the master communication.

Use the following sequence for generating a stop condition.

<1> Set the IICCLn register.

<2> Set the IICCN.IICEn bit.

<3> Set the IICCN.SPTn bit.

### (2) When IICFn.STCENn bit = 1

Immediately after I<sup>2</sup>C0n operation is enabled, the bus released status (IICBSYn bit = 0) is recognized regardless of the actual bus status. To generate the first start condition (IICCN.STTn bit = 1), it is necessary to confirm that the bus has been released, so as to not disturb other communications.

### (3) While communications with other devices are in progress

When the IICCN.IICEn bit of the V850E/SJ3-H or V850E/SK3-H is set to 1 while communications with other devices are in progress, the start condition may be detected depending on the status of the communication line. Be sure to set the IICCN.IICEn bit to 1 when the SCL0n and SDA0n lines are high level.

### (4) Setting the operation clock frequency

Determine the operation clock frequency by the IICCLn, IICXn, and OCKSm registers before enabling the operation (IICCN.IICEn bit = 1). To change the operation clock frequency, clear the IICCN.IICEn bit to 0 once.

### (5) Caution on IICCN register setting

After the IICCN.STTn and IICCN.SPTn bits have been set to 1, they must not be re-set without being cleared to 0 first.

### (6) Transmission reservation

If transmission has been reserved, set the IICCN.SPIEn bit to 1 so that an interrupt request is generated by the detection of a stop condition. After an interrupt request has been generated, the wait state will be released by writing communication data to I<sup>2</sup>Cn, then transferring will begin. If an interrupt is not generated by the detection of a stop condition, transmission will halt in the wait state because an interrupt request was not generated. However, it is not necessary to set the SPIEn bit to 1 for the software to detect the IICSn.MSTSn bit.

**(7) Switching DMA transfer start factor****(a) Switching DMA transfer start factor between INTUA1R and INTIIC2 signals**

Setting the DMA transfer start factor to other than the following combinations is prohibited.

**<1> When using UARTA1 and I<sup>2</sup>C02 simultaneously, and the INTUA1R signal is specified as the DMA transfer start factor (V850E/SK3-H only)**

When the DTFRn.IFCn5 to IFCn0 bits = 28H, set the DTFROB1 bit of the option byte (0000007AH) (see **CHAPTER 33 OPTION BYTE FUNCTION**) to 1. This disables the DMA transfer start factor for the INTIIC2 signal. Therefore, a DMA transfer starts only when the INTUA1R signal is generated. Even if the INTIIC2 signal is generated, DMA transfer does not start.

**<2> When not using UARTA1 and using only I<sup>2</sup>C02, and the INTIIC2 signal is specified as the DMA transfer start factor**

When the DTFRn.IFCn5 to IFCn0 bits = 28H, set the DTFROB1 bit of the option byte (0000007AH) to 0. A DMA transfer starts only when the INTUA1R or INTIIC2 signal is generated.

**<3> When not using I<sup>2</sup>C02 and using only UARTA1, and the INTUA1R signal is specified as the DMA transfer start factor**

When the DTFRn.IFCn5 to IFCn0 bits = 28H, set the DTFROB1 bit of the option byte (0000007AH) to 0. A DMA transfer starts only when the INTUA1R or INTIIC2 signal is generated.

**Remark** For details, see **Table 22-1 DMA Transfer Start Factors**.

**(b) Switching DMA transfer start factor between INTUA2R and INTIIC0 signals**

Setting the DMA transfer start factor to other than the following combinations is prohibited.

**<1> When using UARTA2 and I<sup>2</sup>C00 simultaneously, and the INTUA2R signal is specified as the DMA transfer start factor (V850E/SK3-H only)**

When the DTFRn.IFCn5 to IFCn0 bits = 2AH, set the DTFROB1 bit of the option byte (0000007AH) (see **CHAPTER 33 OPTION BYTE FUNCTION**) to 1. This disables the DMA transfer start factor for the INTIIC0 signal. Therefore, a DMA transfer starts only when the INTUA2R signal is generated. Even if the INTIIC0 signal is generated, DMA transfer does not start.

**<2> When not using UARTA2 and using only I<sup>2</sup>C00, and the INTIIC0 signal is specified as the DMA transfer start factor**

When the DTFRn.IFCn5 to IFCn0 bits = 2AH, set the DTFROB1 bit of the option byte (0000007AH) to 0. A DMA transfer starts only when the INTUA2R or INTIIC0 signal is generated.

**<3> When not using I<sup>2</sup>C00 and using only UARTA2, and the INTUA2R signal is specified as the DMA transfer start factor**

When the DTFRn.IFCn5 to IFCn0 bits = 2AH, set the DTFROB1 bit of the option byte (0000007AH) to 0. A DMA transfer starts only when the INTUA2R or INTIIC0 signal is generated.

**Remark** For details, see **Table 22-1 DMA Transfer Start Factors**.

## 19.16 Communication Operations

The following shows three operation procedures with the flowchart.

### (1) Master operation in single master system

The flowchart when using the V850E/SJ3-H or V850E/SK3-H as the master in a single master system is shown below.

This flowchart is broadly divided into the initial settings and communication processing. Execute the initial settings at startup. If communication with the slave is required, prepare the communication and then execute communication processing.

### (2) Master operation in multimaster system

In the I<sup>2</sup>C0n bus multimaster system, whether the bus is released or used cannot be judged by the I<sup>2</sup>C bus specifications when the bus takes part in a communication. Here, when data and clock are at a high level for a certain period (1 frame), the V850E/SJ3-H or V850E/SK3-H takes part in a communication with bus released state.

This flowchart is broadly divided into the initial settings, communication waiting, and communication processing. The processing when the V850E/SJ3-H or V850E/SK3-H loses in arbitration and is specified as the slave is omitted here, and only the processing as the master is shown. Execute the initial settings at startup to take part in a communication. Then, wait for the communication request as the master or wait for the specification as the slave. The actual communication is performed in the communication processing, and it supports the transmission/reception with the slave and the arbitration with other masters.

### (3) Slave operation

An example of when the V850E/SJ3-H or V850E/SK3-H is used as the slave of the I<sup>2</sup>C0n bus is shown below.

When used as the slave, operation is started by an interrupt. Execute the initial settings at startup, then wait for the INTIICn interrupt occurrence (communication waiting). When the INTIICn interrupt occurs, the communication status is judged and its result is passed as a flag over to the main processing.

By checking the flags, necessary communication processing is performed.

<R> **Remark** Only  $\mu$ PD70F3931 (V850E/SJ3-H), 70F3932 (V850E/SJ3-H), and 70F3933 (V850E/SJ3-H): n = 0 to 3  
Other than  $\mu$ PD70F3931 (V850E/SJ3-H), 70F3932 (V850E/SJ3-H), and 70F3933 (V850E/SJ3-H): n = 0 to 5



19.16.1 Master operation in single master system

Figure 19-15. Master Operation in Single Master System

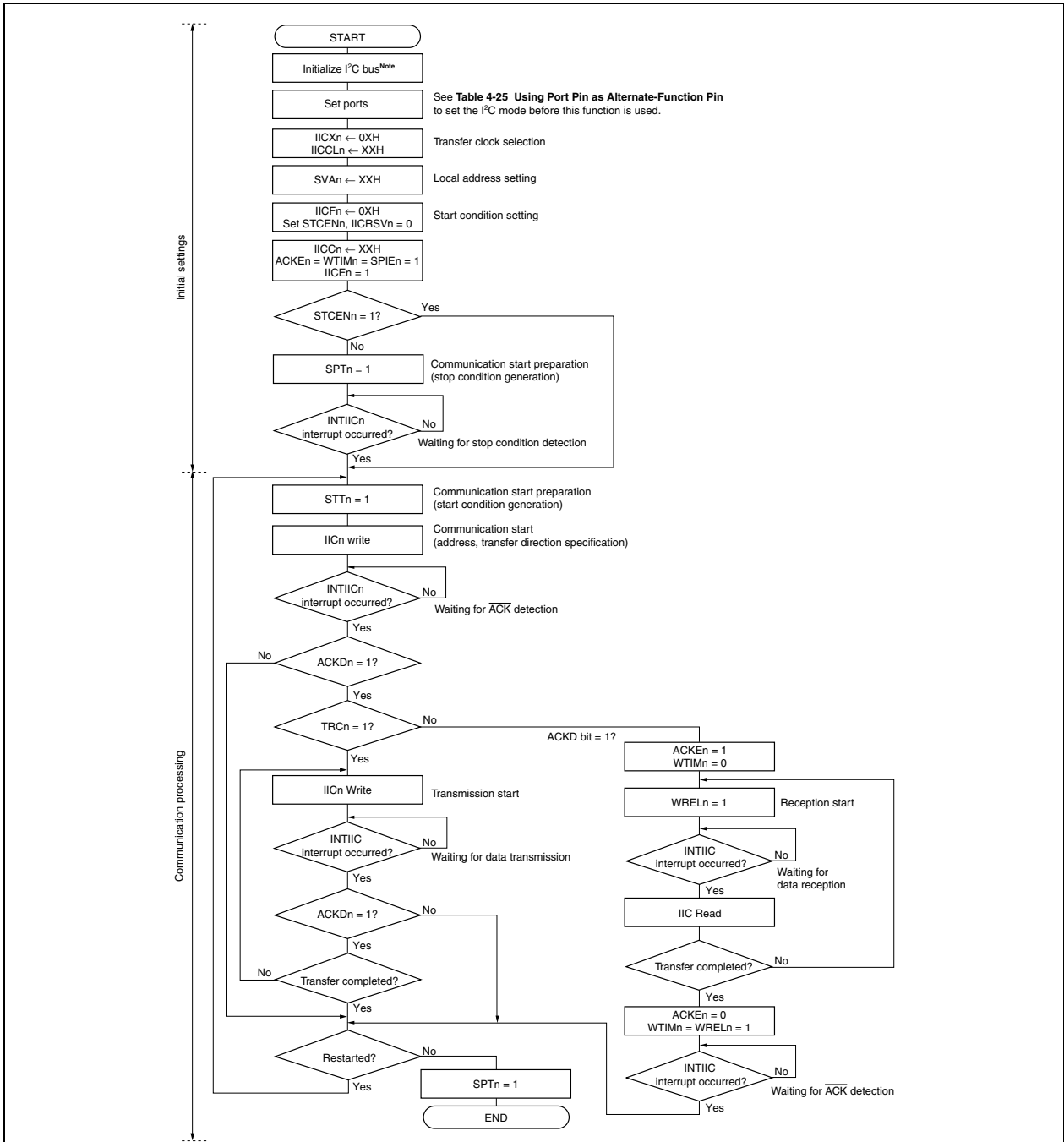

**Note** Release the I<sup>2</sup>C<sub>0n</sub> bus (SCL<sub>0n</sub>, SDA<sub>0n</sub> pins = high level) in conformity with the specifications of the product in communication.

For example, when the EEPROM™ outputs a low level to the SDA<sub>0n</sub> pin, set the SCL<sub>0n</sub> pin to the output port and output clock pulses from that output port until when the SDA<sub>0n</sub> pin is constantly high level.

**Remarks 1.** For the transmission and reception formats, conform to the specifications of the product in communication.

2. Only  $\mu$ PD70F3931 (V850E/SJ3-H), 70F3932 (V850E/SJ3-H), and 70F3933 (V850E/SJ3-H): n = 0 to 3  
Other than  $\mu$ PD70F3931 (V850E/SJ3-H), 70F3932 (V850E/SJ3-H), and 70F3933 (V850E/SJ3-H):  
n = 0 to 5

<R>

19.16.2 Master operation in multimaster system

Figure 19-16. Master Operation in Multimaster System (1/3)

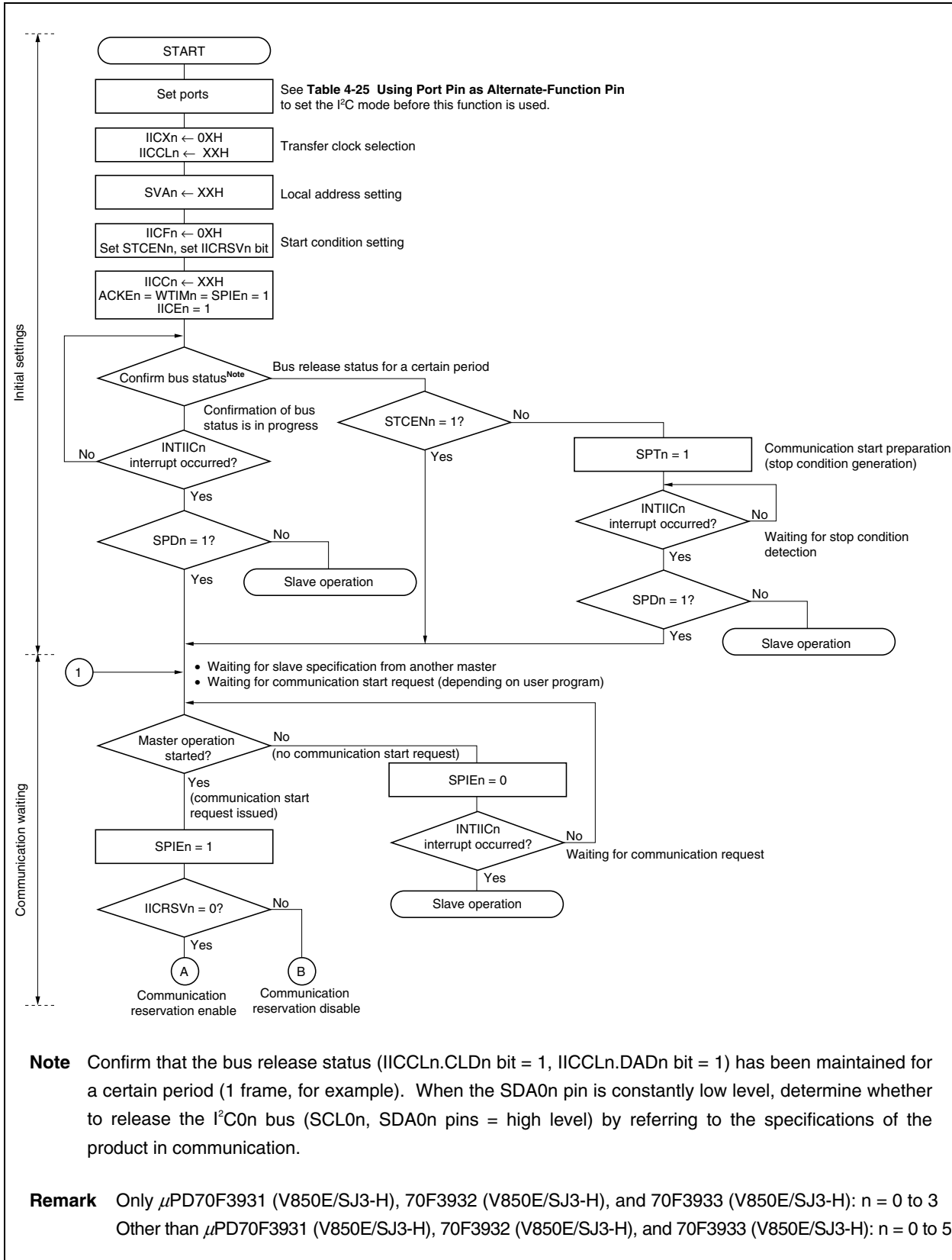
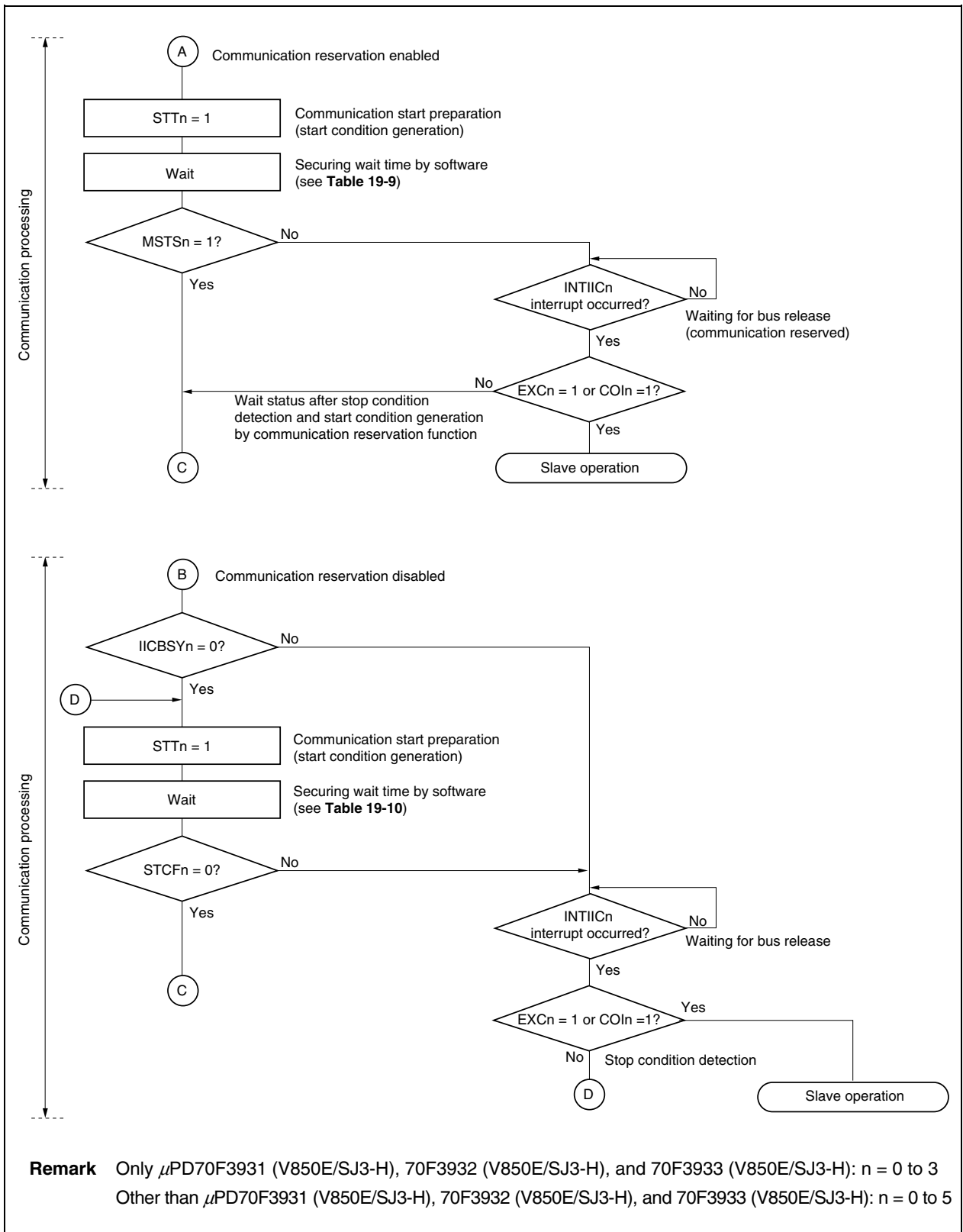
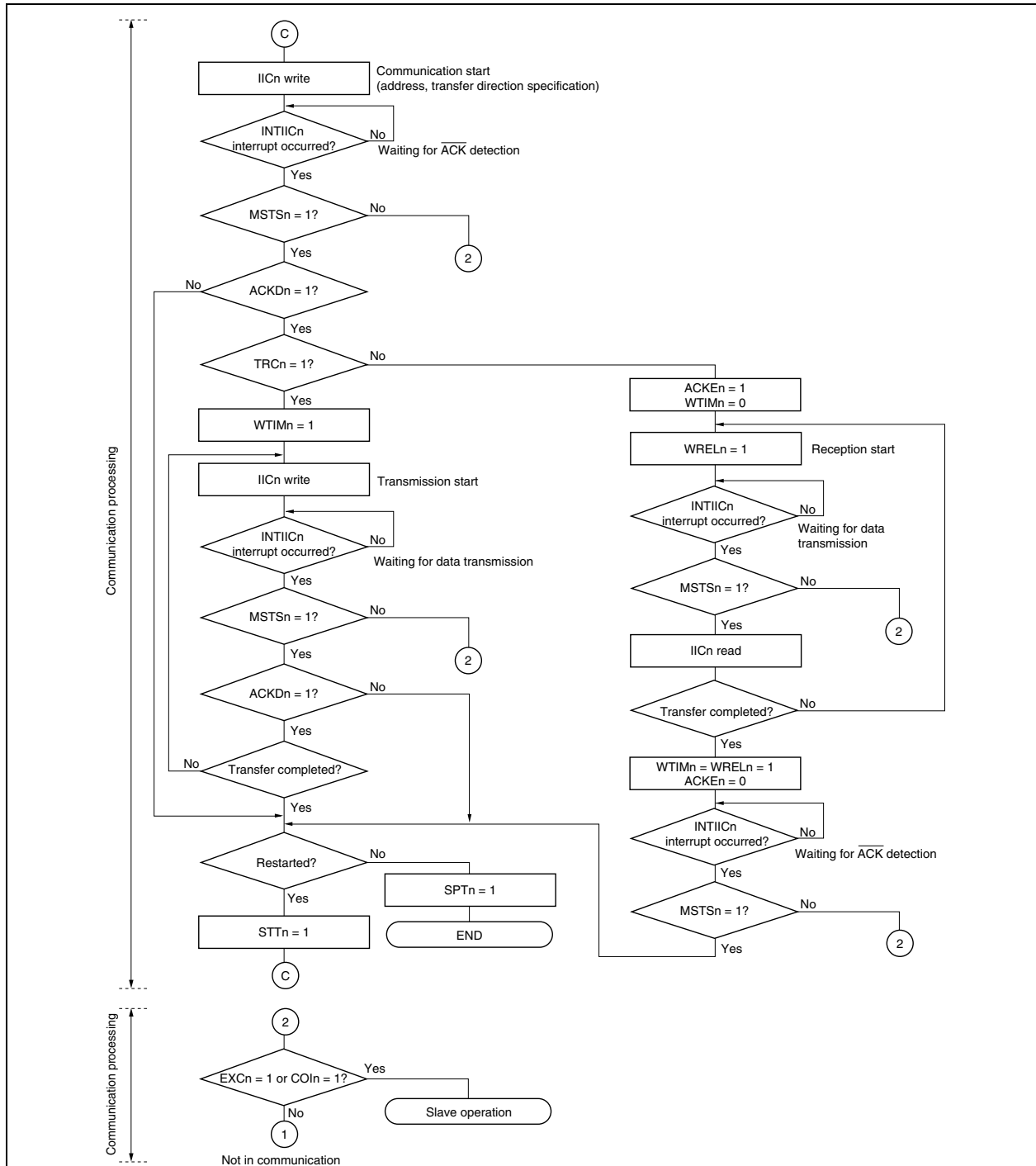

Figure 19-16. Master Operation in Multimaster System (2/3)



<R>

Figure 19-16. Master Operation in Multimaster System (3/3)



- Remarks**
1. Conform the transmission and reception formats to the specifications of the product in communication.
  2. When using the V850E/SJ3-H or V850E/SK3-H as the master in the multimaster system, read the IICSn.MSTSn bit for each INTIICn interrupt occurrence to confirm the arbitration result.
  3. When using the V850E/SJ3-H or V850E/SK3-H as the slave in the multimaster system, confirm the status using the IICSn and IICFn registers for each INTIICn interrupt occurrence to determine the next processing.
  4. Only  $\mu$ PD70F3931 (V850E/SJ3-H), 70F3932 (V850E/SJ3-H), and 70F3933 (V850E/SJ3-H): n = 0 to 3  
Other than  $\mu$ PD70F3931 (V850E/SJ3-H), 70F3932 (V850E/SJ3-H), and 70F3933 (V850E/SJ3-H): n = 0 to 5

<R>

### 19.16.3 Slave operation

The following shows the processing procedure of the slave operation.

Basically, the operation of the slave device is event-driven. Therefore, processing by an INTIICn interrupt (processing requiring a significant change of the operation status, such as stop condition detection during communication) is necessary.

The following description assumes that data communication does not support extension codes. Also, it is assumed that the INTIICn interrupt servicing performs only status change processing and that the actual data communication is performed during the main processing.

**Figure 19-17. Software Outline During Slave Operation**

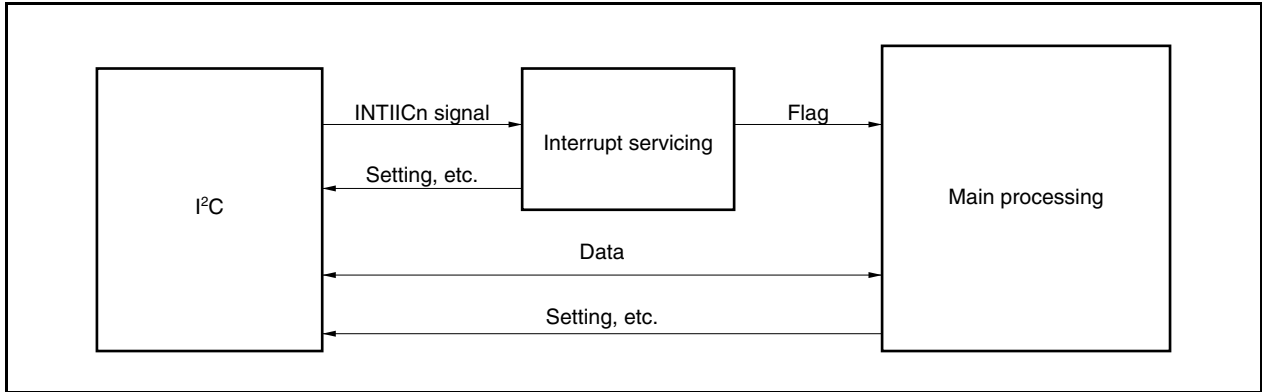

Therefore, the following three flags are prepared so that the data transfer processing can be performed by transmitting these flags to the main processing instead of INTIICn signal.

#### (1) Communication mode flag

This flag indicates the following communication statuses.

Clear mode: Data communication not in progress

Communication mode: Data communication in progress (valid address detection stop condition detection,  $\overline{\text{ACK}}$  from master not detected, address mismatch)

#### (2) Ready flag

This flag indicates that data communication is enabled. This is the same status as an INTIICn interrupt during normal data transfer. This flag is set in the interrupt servicing block and cleared in the main processing block. The ready flag for the first data for transmission is not set in the interrupt servicing block, so the first data is transmitted without clear processing (the address match is regarded as a request for the next data).

#### (3) Communication direction flag

This flag indicates the direction of communication and is the same as the value of IICSn.TRCn bit.

The following shows the operation of the main processing block during slave operation.

Start I<sup>2</sup>C0n and wait for the communication enabled status. When communication is enabled, perform transfer using the communication mode flag and ready flag (the processing of the stop condition and start condition is performed by interrupts, conditions are confirmed by flags).

For transmission, repeat the transmission operation until the master device stops returning  $\overline{ACK}$ . When the master device stops returning  $\overline{ACK}$ , transfer is complete.

For reception, receive the required number of data and do not return  $\overline{ACK}$  for the next data immediately after transfer is complete. After that, the master device generates the stop condition or restart condition. This causes exit from communications.

Figure 19-18. Slave Operation Flowchart (1)

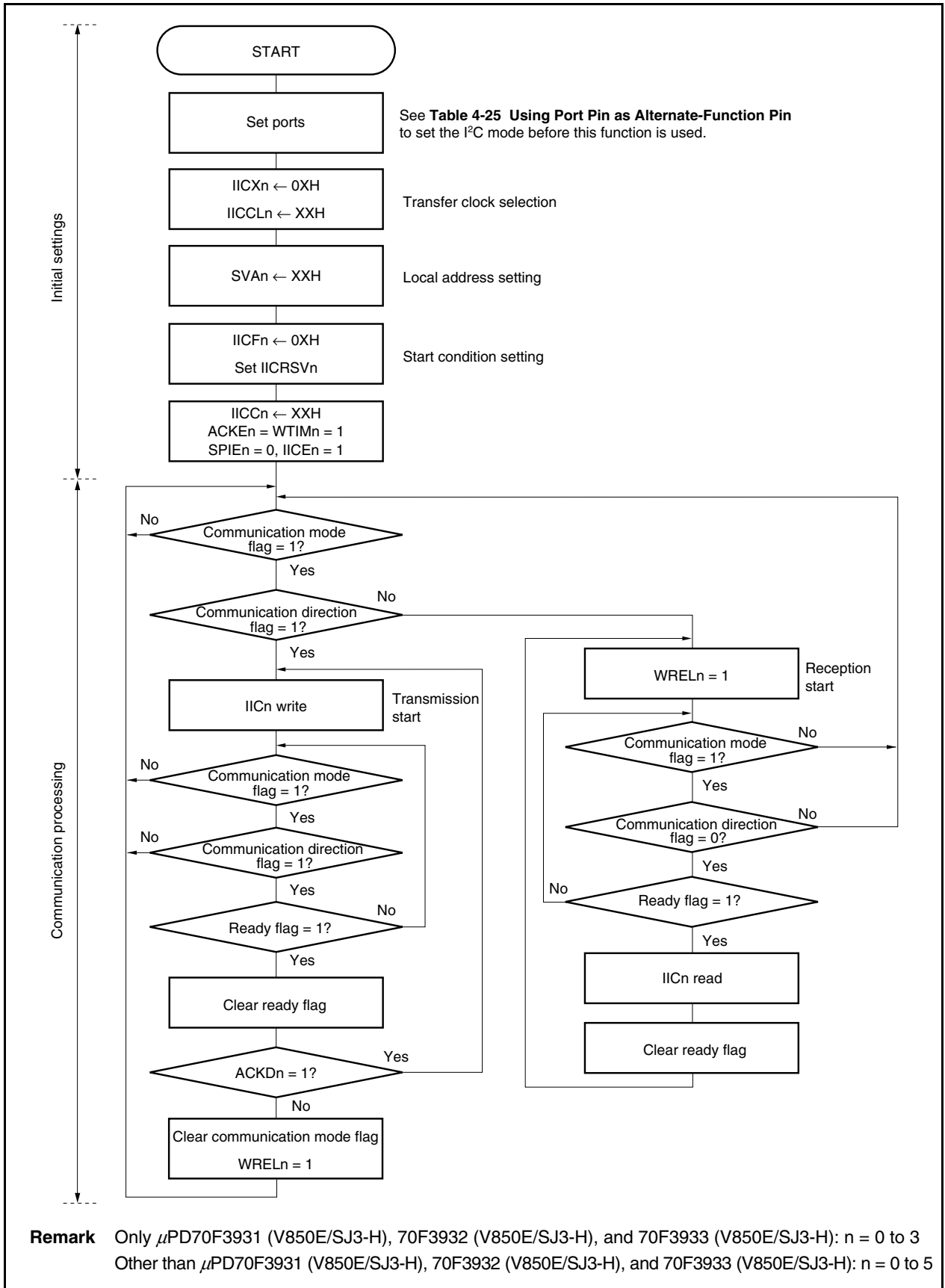

<R>

**Remark** Only  $\mu$ PD70F3931 (V850E/SJ3-H), 70F3932 (V850E/SJ3-H), and 70F3933 (V850E/SJ3-H): n = 0 to 3  
 Other than  $\mu$ PD70F3931 (V850E/SJ3-H), 70F3932 (V850E/SJ3-H), and 70F3933 (V850E/SJ3-H): n = 0 to 5

The following shows an example of the processing of the slave device by an INTIICn interrupt (it is assumed that no extension codes are used here). During an INTIICn interrupt, the status is confirmed and the following steps are executed.

- <1> When a stop condition is detected, communication is terminated.
- <2> When a start condition is detected, the address is confirmed. If the address does not match, communication is terminated. If the address matches, the communication mode is set and wait state is released, and operation returns from the interrupt (the ready flag is cleared).
- <3> For data transmission/reception, when the ready flag is set, operation returns from the interrupt while the I<sup>2</sup>C0n bus remains in the wait state.

**Remark** <1> to <3> in the above correspond to <1> to <3> in **Figure 19-19 Slave Operation Flowchart (2)**.

**Figure 19-19. Slave Operation Flowchart (2)**

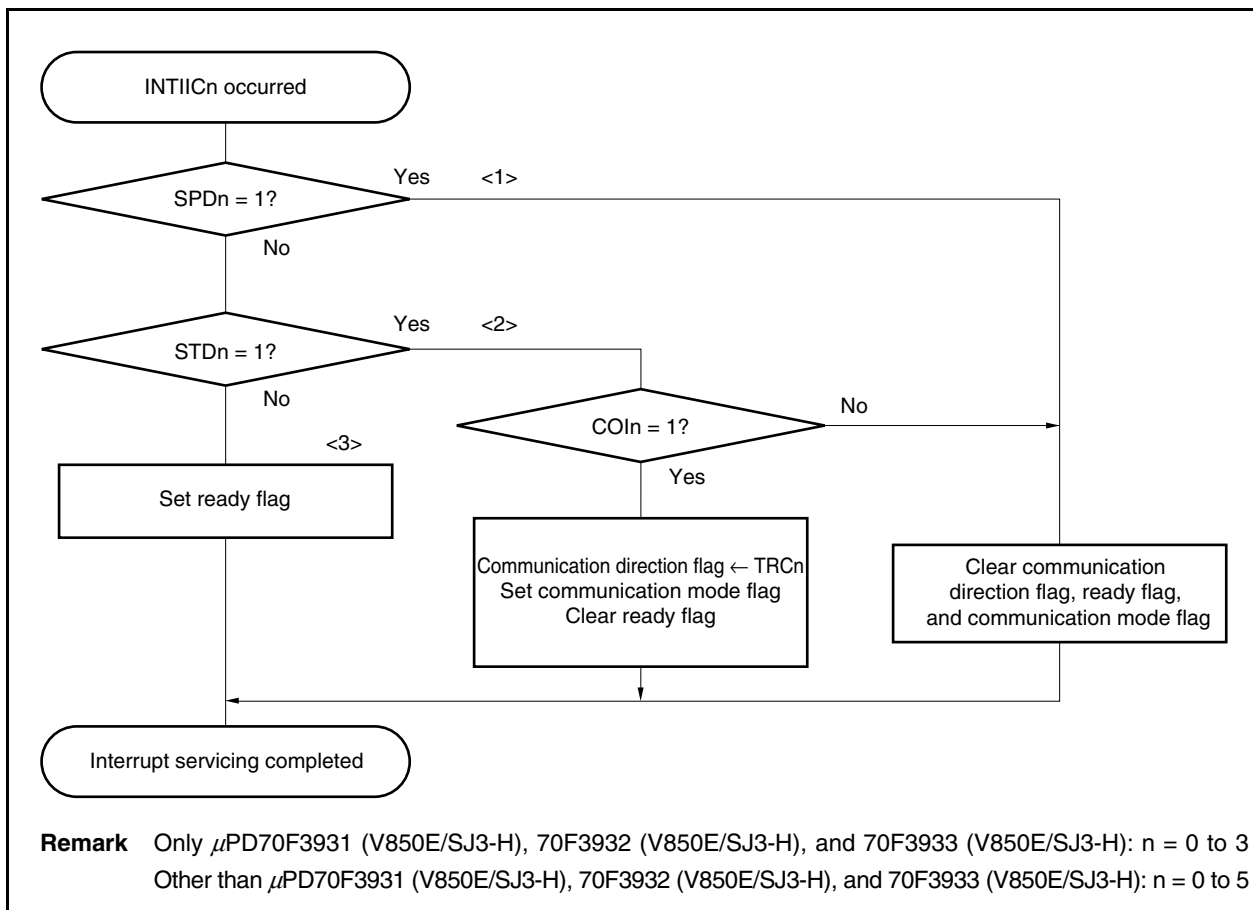



### 19.17 Timing of Data Communication

When using I<sup>2</sup>C bus mode, the master device generates an address via the serial bus to select one of several slave devices as its communication partner.

After outputting the slave address, the master device transmits the IICSn.TRCn bit, which specifies the data transfer direction, and then starts serial communication with the slave device.

The shift operation of the IICn register is synchronized with the falling edge of the serial clock pin (SCL0n). The transmit data is transferred to the SO latch and is output (MSB first) via the SDA0n pin.

Data input via the SDA0n pin is captured by the IICn register at the rising edge of the SCL0n pin.

The data communication timing is shown below.

<R>      **Remark**    Only  $\mu$ PD70F3931 (V850E/SJ3-H), 70F3932 (V850E/SJ3-H), and 70F3933 (V850E/SJ3-H): n = 0 to 3  
                 Other than  $\mu$ PD70F3931 (V850E/SJ3-H), 70F3932 (V850E/SJ3-H), and 70F3933 (V850E/SJ3-H): n = 0 to 5

**Figure 19-20. Example of Master to Slave Communication  
(When 9-Clock Wait Is Selected for Both Master and Slave) (1/3)**

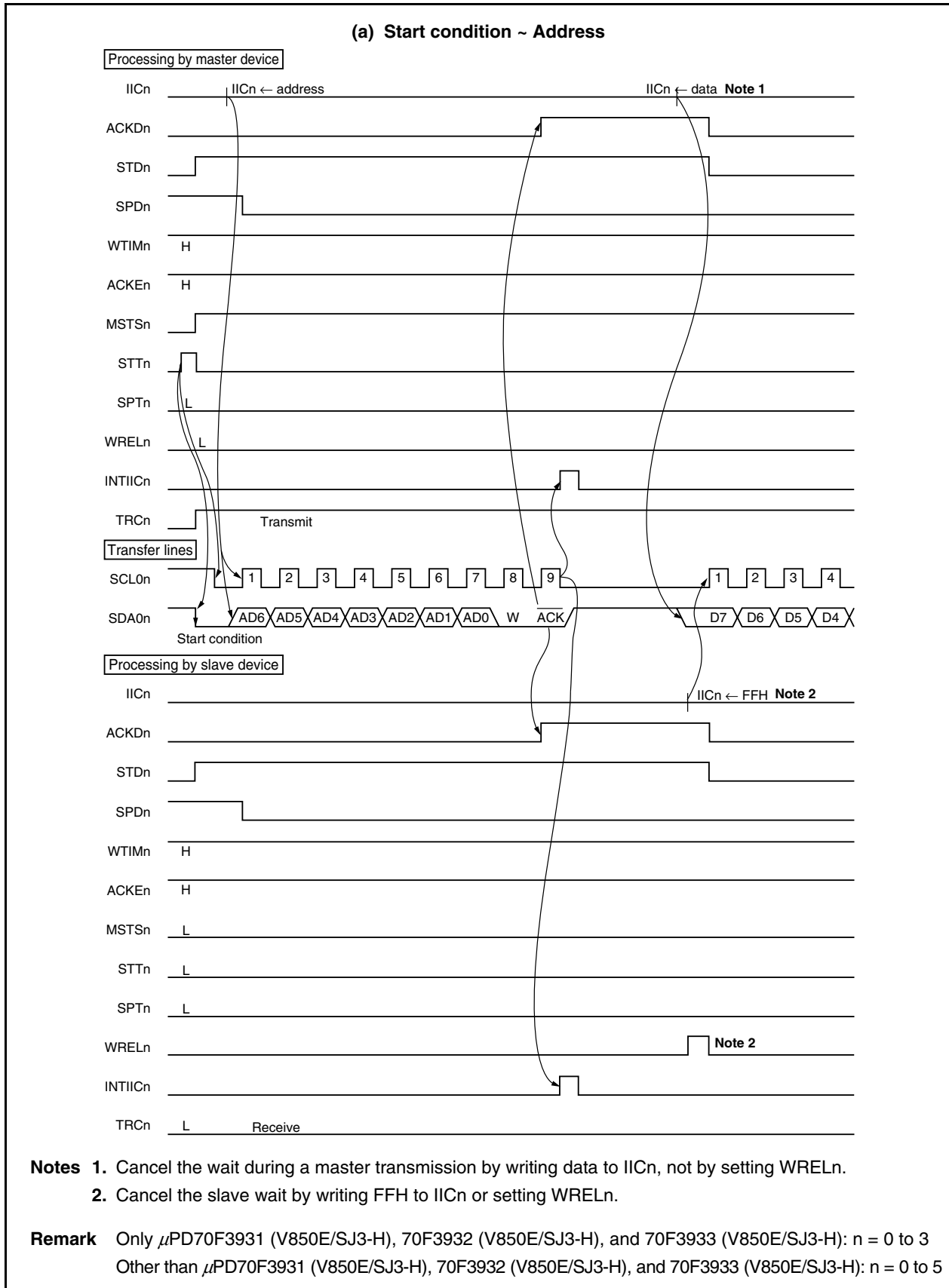

**Figure 19-20. Example of Master to Slave Communication  
(When 9-Clock Wait Is Selected for Both Master and Slave) (2/3)**

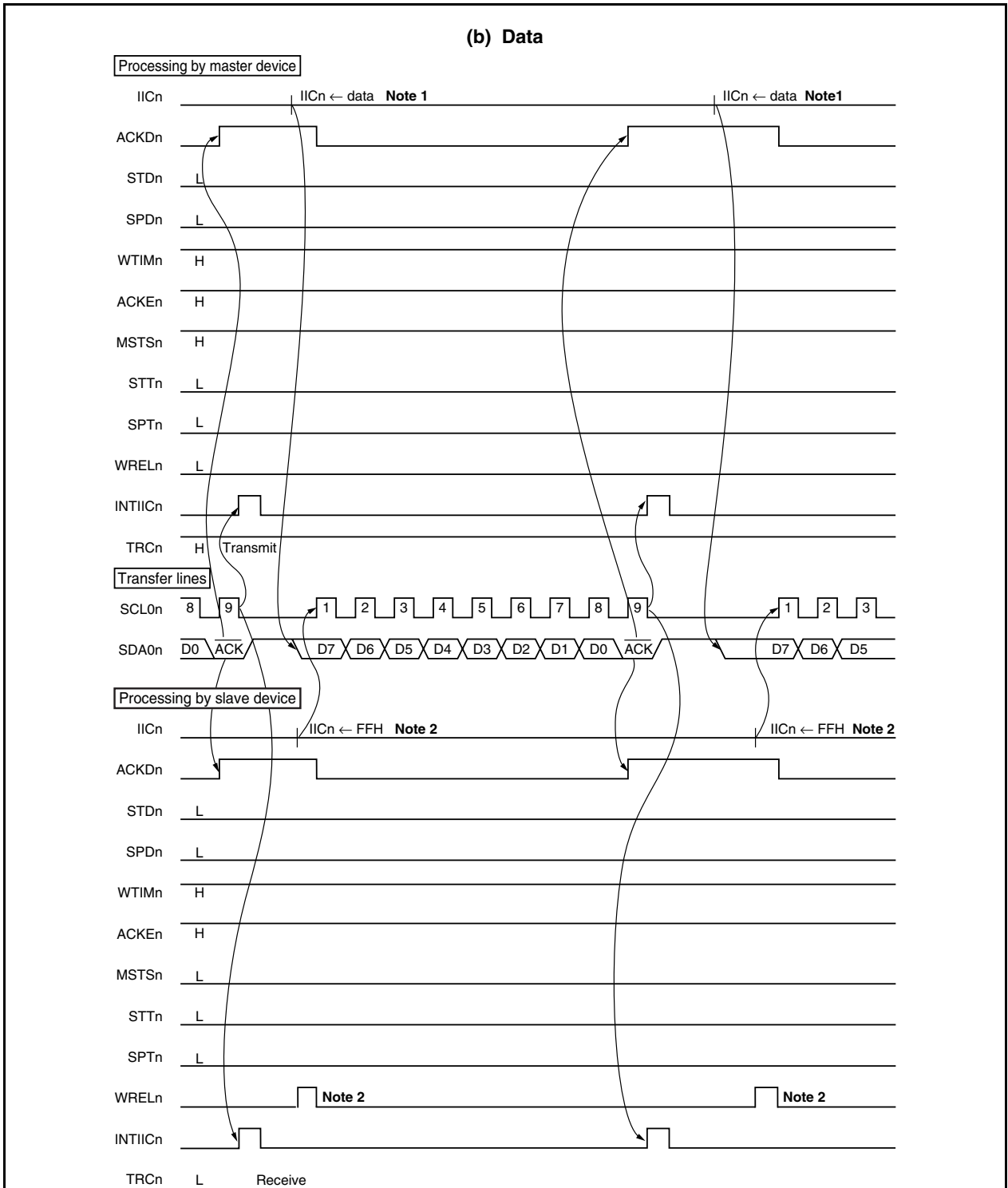

- Notes** 1. Cancel the wait during a master transmission by writing data to IICn, not by setting WRELn.  
 2. Cancel the slave wait by writing FFH to IICn or setting WRELn.

**Remark** Only  $\mu$ PD70F3931 (V850E/SJ3-H), 70F3932 (V850E/SJ3-H), and 70F3933 (V850E/SJ3-H): n = 0 to 3  
 Other than  $\mu$ PD70F3931 (V850E/SJ3-H), 70F3932 (V850E/SJ3-H), and 70F3933 (V850E/SJ3-H): n = 0 to 5

<R>

**Figure 19-20. Example of Master to Slave Communication  
(When 9-Clock Wait Is Selected for Both Master and Slave) (3/3)**

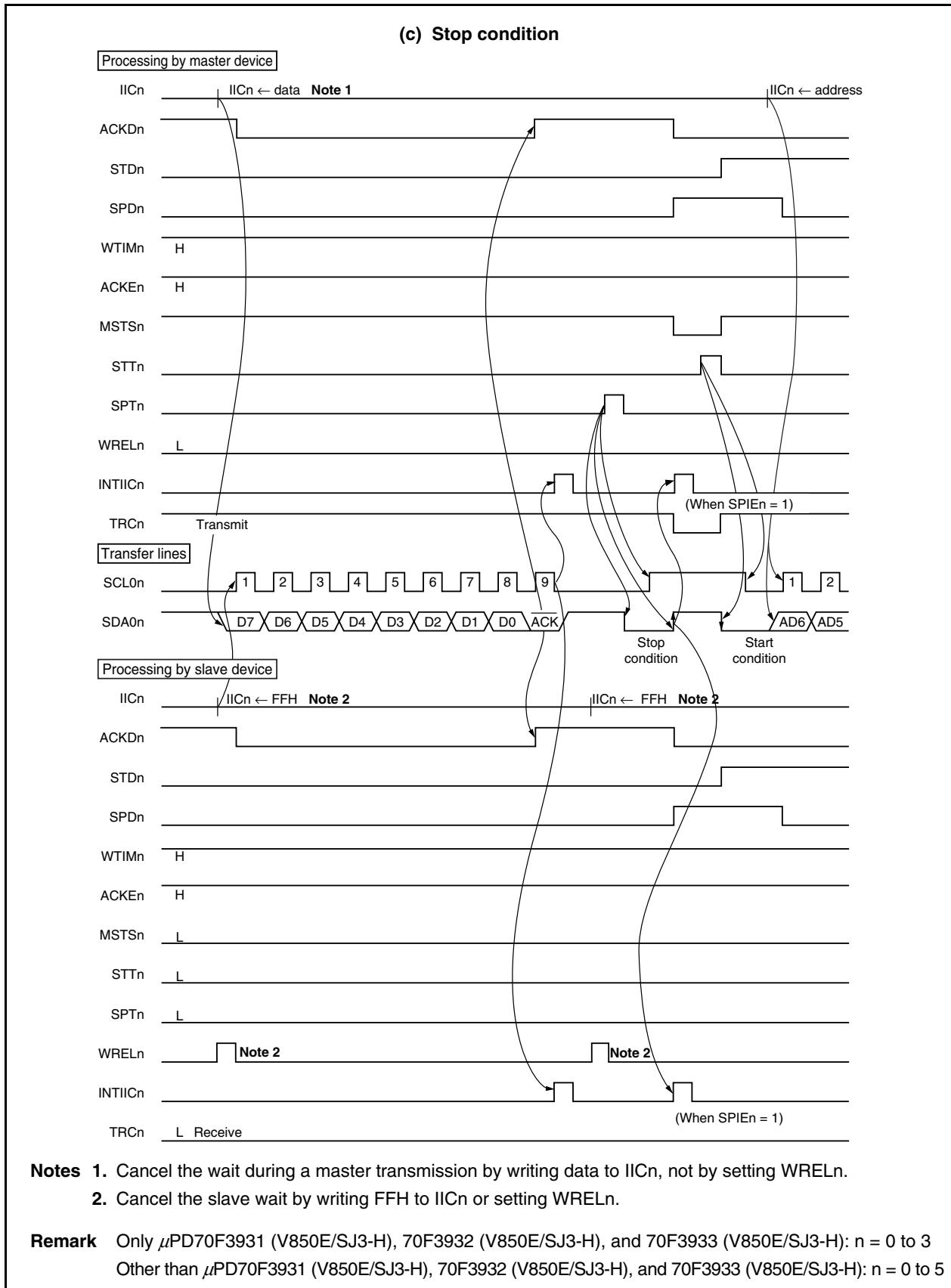

<R>

**Figure 19-21. Example of Slave to Master Communication**  
**(When 8-Clock Wait for Master and 9-Clock Wait for Slave Are Selected) (1/3)**

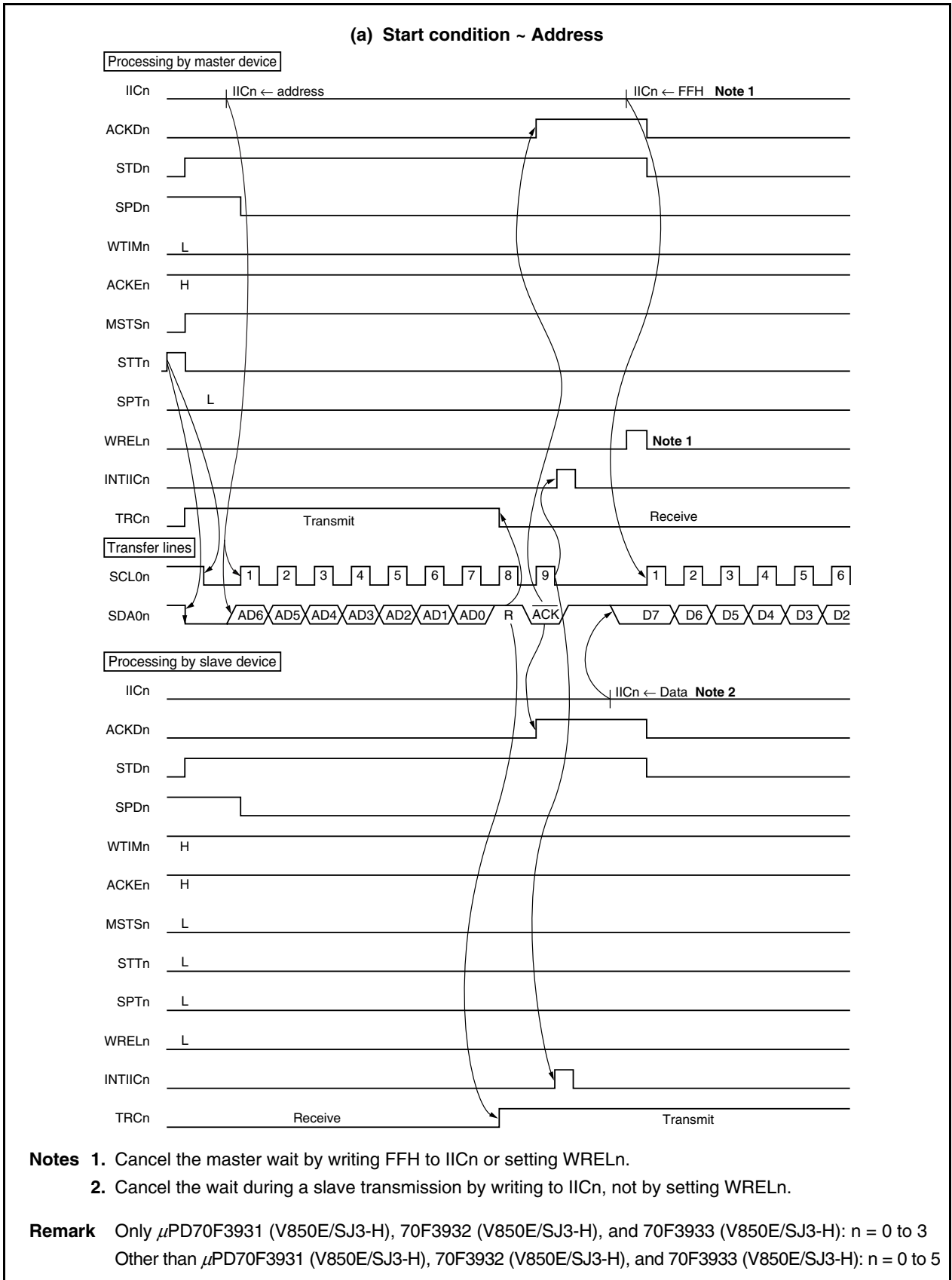

<R>

**Figure 19-21. Example of Slave to Master Communication  
(When 8-Clock Wait for Master and 9-Clock Wait for Slave Are Selected) (2/3)**

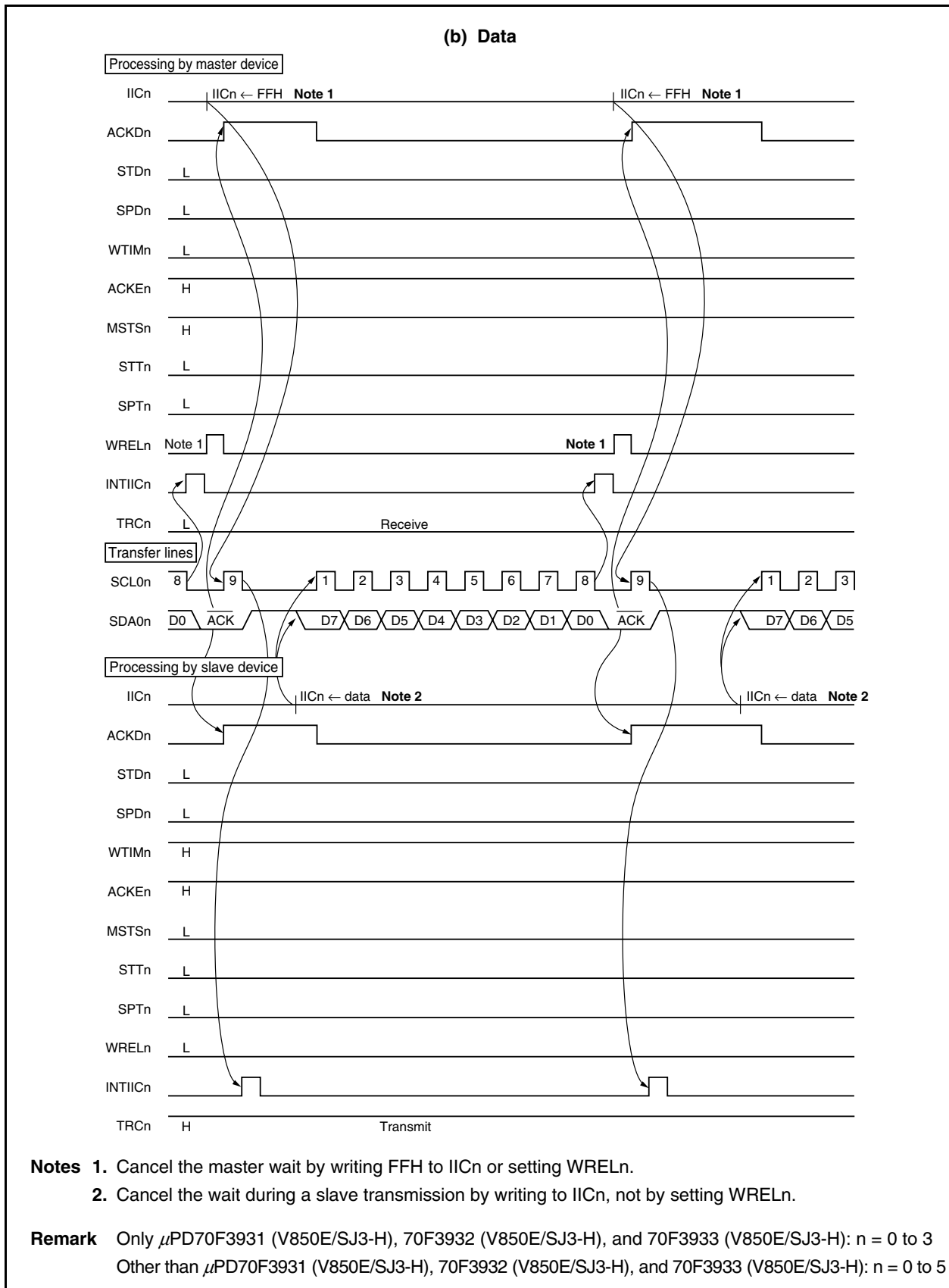

**Figure 19-21. Example of Slave to Master Communication**  
**(When 8-Clock → 9-Clock Wait for Master and 9-Clock Wait for Slave Are Selected) (3/3)**

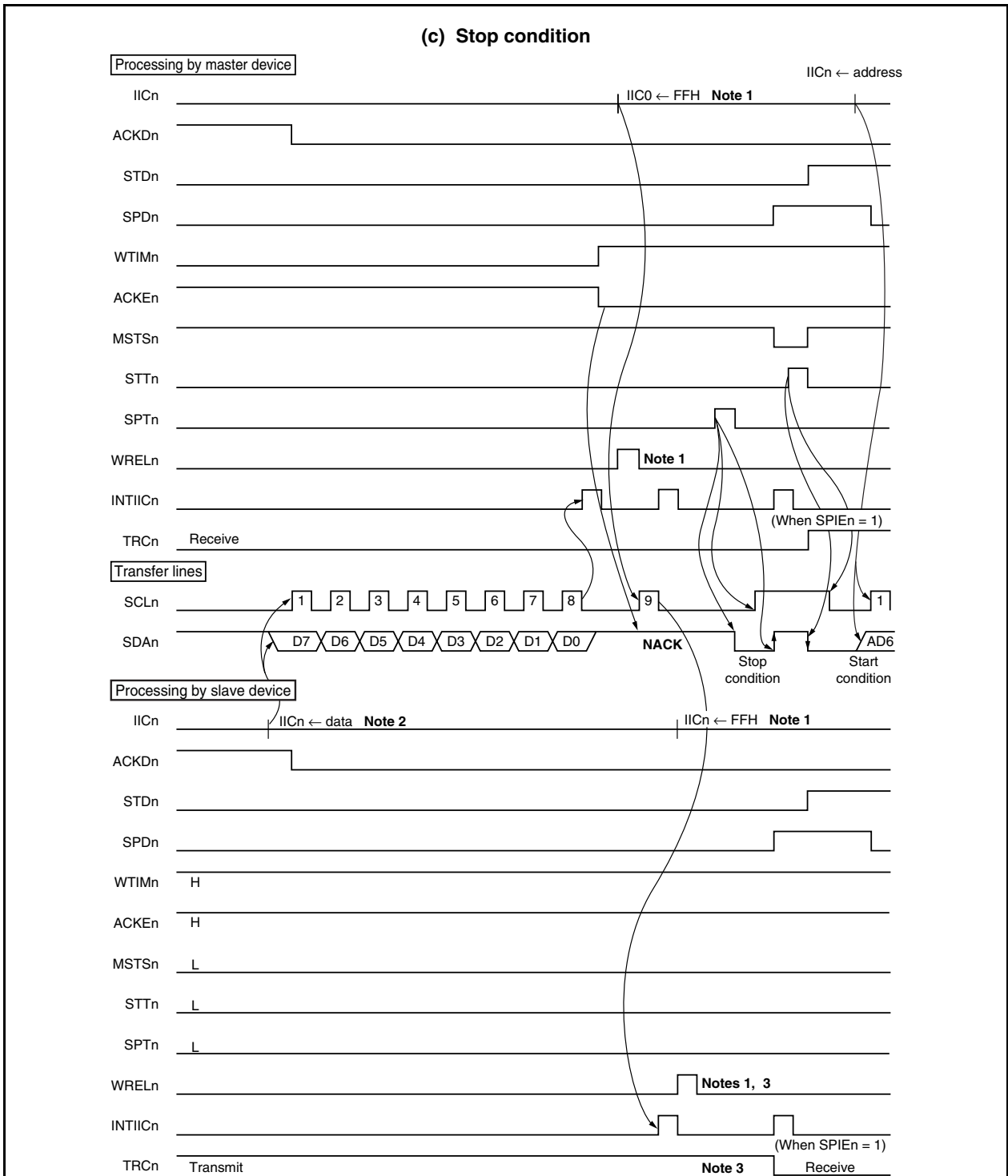

- Notes**
1. Cancel the wait by writing FFH to IICn, or setting WRELn.
  2. Cancel the wait during a slave transmission by writing to IICn, not by setting WRELn.
  3. When the wait during a slave transmission is canceled by setting WRELn, TRCn is cleared.

**Remark** Only  $\mu$ PD70F3931 (V850E/SJ3-H), 70F3932 (V850E/SJ3-H), and 70F3933 (V850E/SJ3-H): n = 0 to 3  
 Other than  $\mu$ PD70F3931 (V850E/SJ3-H), 70F3932 (V850E/SJ3-H), and 70F3933 (V850E/SJ3-H): n = 0 to 5

<R>

## CHAPTER 20 IEBus CONTROLLER

IEBus (Inter Equipment Bus) is a small-scale digital data transfer system that transfers data between units. To implement IEBus with the V850E/SJ3-H and V850E/SK3-H, an external IEBus driver and receiver are necessary because they are not provided.

The internal IEBus controllers of the V850E/SJ3-H and V850E/SK3-H are of negative logic.

### 20.1 Functions

#### 20.1.1 Communication protocol of IEBus

The communication protocol of the IEBus is as follows.

##### (1) Multi-task mode

All the units connected to the IEBus can transfer data to the other units.

##### (2) Broadcasting communication function

Communication between one unit and multiple units can be performed as follows.

- Group-unit broadcast communication: Broadcast communication to group units
- All-unit broadcast communication: Broadcast communication to all units.

##### (3) Effective transfer rate

The effective transfer rate is in mode 1 or mode 2 (the V850E/SJ3-H and V850E/SK3-H do not support mode 0 for the effective transfer rate).

- Mode 1: Approx. 17 kbps
- Mode 2: Approx. 26 kbps

**Caution** Different modes (mode 1, mode 2) must not be mixed on one IEBus.

##### (4) Communication mode

Data transfer is executed in half-duplex asynchronous communication mode.

##### (5) Access control: CSMA/CD (Carrier Sense Multiple Access with Collision Detection)

The priority of the IEBus is as follows:

- <1> Broadcast communication takes precedence over individual communication (communication from one unit to another).
- <2> The lower master address takes precedence.

##### (6) Communication scale

The communication scale of IEBus is as follows.

- Number of units: 50 MAX.
- Cable length: 150 m MAX. (when twisted pair cable is used)

**Caution** The communication scale in an actual system differs depending on the characteristics of the cables, etc., constituting the IEBus driver/receiver and IEBus.



### 20.1.2 Determination of bus mastership (arbitration)

An operation to occupy the bus is performed when a unit connected to the IEBus controls the other units. This operation is called arbitration.

When two or more units simultaneously start transmission, arbitration is used to grant one of the units the permission to occupy the bus.

Because only one unit is granted the bus mastership as a result of arbitration, the priority conditions of the bus are predetermined as follows.

**Caution** The bus mastership is released if communication is aborted.

#### (1) Priority by communication type

Broadcast communication (communication from one unit to multiple units) takes precedence over normal communication (communication from one unit to another).

#### (2) Priority by master address

If the communication type is the same, communication with the lower master address takes precedence.

A master address consists of 12 bits, with unit 000H having the highest priority and unit FFFH having the lowest priority.

### 20.1.3 Communication mode

The IEBus has three communication modes each having a different transfer rate. The V850E/SJ3-H and V850E/SK3-H support communication modes 1 and 2. The transfer rate and the maximum number of transfer bytes in one communication frame in communication modes 1 and 2 are as shown in Table 20-1.

**Table 20-1. Transfer Rate and Maximum Number of Transfer Bytes in Each Communication Mode**

Communication Mode	Maximum Number of Transfer Bytes (Bytes/Frame)	Effective Transfer Rate (kbps) <sup>Note</sup>
1	32	Approx. 17
2	128	Approx. 26

**Note** The effective transfer rate when the maximum number of transfer bytes is transmitted

Select the communication mode for each unit connected to the IEBus before starting communication. If the communication mode of the master unit and that of the partner unit (slave unit) are not the same, communication is not correctly executed.

### 20.1.4 Communication address

With the IEBus, each unit is assigned a specific 12-bit address. This communication address consists of the following identification numbers.

- Higher 4 bits: Group number (number to identify the group to which each unit belongs)
- Lower 8 bits: Unit number (number to identify each unit in a group)

**20.1.5 Broadcast communication**

Normally, transmission or reception is performed between the master unit and its partner slave unit on a one-to-one basis. During broadcast communication, however, two or more slave units exist and the master unit executes transmission to these slave units. Because two or more slave units exist, the NACK signal is returned by the communicating slave unit as an acknowledge bit.

Whether broadcast communication or normal communication is to be executed is selected by the broadcast bit (for this bit, see **20.1.6 (2) Broadcast bit**).

Broadcast communication is classified into two types: group-unit broadcast communication and all-unit broadcast communication. Group-unit broadcast and all-unit broadcast are identified by the value of the slave address (for the slave address, see **20.1.6 (4) Slave address field**).

**(1) Group-unit broadcast communication**

Broadcast communication is performed to the units in a group identified by the group number indicated by the higher 4 bits of the communication address.

**(2) All-unit broadcast communication**

Broadcast communication is performed to all the units, regardless of the value of the group number.

**20.1.6 Transfer format of IEBus**

Figure 20-1 shows the transfer signal format of the IEBus.

**Figure 20-1. IEBus Transfer Signal Format**

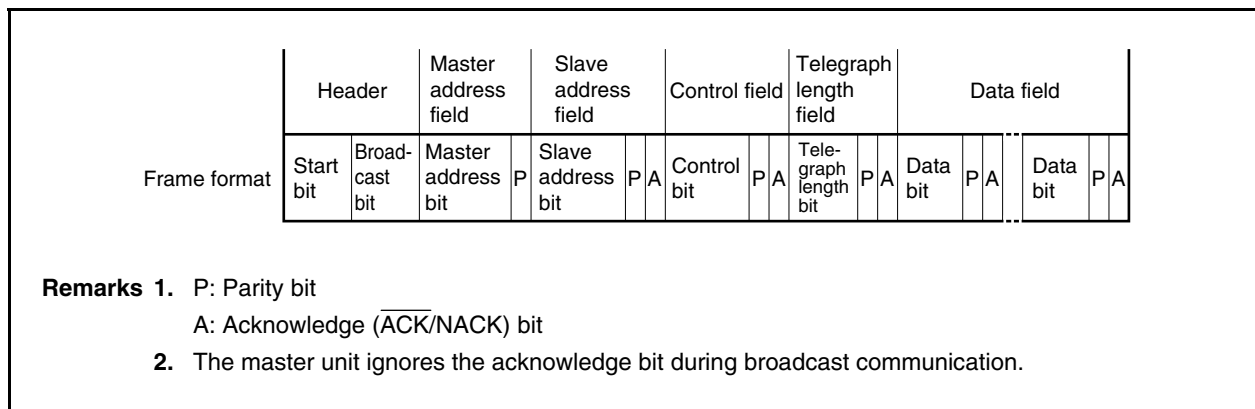

**(1) Start bit**

The start bit is a signal that informs the other units of the start of data transfer. The unit that is to start data transfer outputs a high-level signal (start bit) from the IETX pin for a specific time, and then starts outputting the broadcast bit.

If another unit has already output its start bit when one unit is to output the start bit, this unit does not output the start bit but waits for completion of output of the start bit by the other unit. When the output of the start bit by the other unit is complete, the unit starts outputting the broadcast bit in synchronization with the completion of the start bit output by the other unit.

The units other than the one that has started communication detect this start bit, and enter the reception status.

**(2) Broadcast bit**

This bit indicates whether the master selects one slave (individual communication) or multiple slaves (broadcast communication) as the other party of communication.

When the broadcast bit is 0, it indicates broadcast communication; when it is 1, individual communication is indicated. Broadcast communication is classified into two types: group-unit communication and all-unit communication. These communication types are identified by the value of the slave address (for the slave address, see **20.1.6 (4) Slave address field**).

Because two or more slave units exist as a partner slave unit of communication in the case of broadcast communication, the NACK signal is returned as an acknowledge bit in each field subsequent to the master address field.

If two or more units start transmitting a communication frame at the same time, broadcast communication takes precedence over individual communication, and wins in arbitration.

If one unit occupies the bus as the master, the value set to the broadcast request flag (BCR.ALLRQ bit) is output.

**(3) Master address field**

The master address field is output by the master to inform a slave of the master's address.

The configuration of the master address field is as shown in Figure 20-2.

If two or more units start transmitting the broadcast bit at the same time, the master address field makes a judgment of arbitration.

The master address field compares the data it outputs with the data on the bus each time it has output one bit. If the master address output by the master address field is found to be different from the data on the bus as a result of comparison, it is assumed that the master has lost in arbitration. As a result, the master stops transmission and enters the reception status.

Because the IEBus is configured of wired AND, the unit having the minimum master address of the units participating in arbitration (arbitration masters) wins in arbitration.

After a 12-bit master address has been output, only one unit remains in the transmission status as one master unit.

Next, this master unit outputs a parity bit, determines the master address of other unit, and starts outputting a slave address field.

If one unit occupies the bus as the master, the address set by the UAR register is output.

**Figure 20-2. Master Address Field**

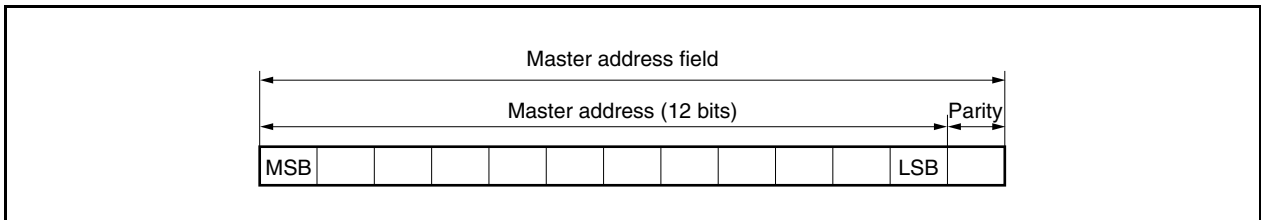

**(4) Slave address field**

The master outputs the address of the unit with which it is to communicate.

Figure 20-3 shows the configuration of the slave address field.

A parity bit is output after a 12-bit slave address has been transmitted in order to prevent a wrong slave address from being received by mistake. Next, the master unit detects an  $\overline{\text{ACK}}$  signal from the slave unit to confirm that the slave unit exists on the bus. When the master has detected the  $\overline{\text{ACK}}$  signal, it starts outputting the control field. During broadcast communication, however, the master does not confirm the acknowledge bit but starts outputting the control field.

The slave unit outputs the  $\overline{\text{ACK}}$  signal if its slave address matches and if the slave detects that the parities of both the master address and slave address are even. The slave unit judges that the master address or slave address has not been correctly received and outputs the NACK signal if the parities are odd. At this time, the master unit is in the standby (monitor) status, and communication ends.

During broadcast communication, the slave address is used to identify group-unit broadcast or all-unit broadcast, as follows:

- If slave address is FFFH: All-unit broadcast communication
- If slave address is other than FFFH: Group-unit broadcast communication

**Remark** The group No. during group-unit broadcasting communication is the value of the higher 4 bits of the slave address.

If one unit occupies the bus as the master, the address set by the SAR register is output.

**Figure 20-3. Slave Address Field**

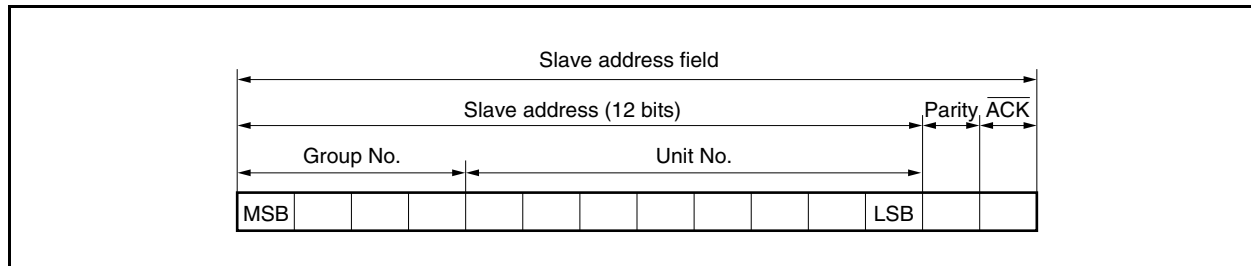

**(5) Control field**

The master outputs the operation it requires the slave to perform, by using this field.

The configuration of the control field is as shown in Figure 20-4.

If the parity following the control bit is even and if the slave unit can execute the function required by the master unit, the slave unit outputs an  $\overline{\text{ACK}}$  signal and starts outputting the telegraph length field. If the slave unit cannot execute the function required by the master unit even if the parity is even, or if the parity is odd, the slave unit outputs the NACK signal, and returns to the standby (monitor) status.

The master unit starts outputting the telegraph field after detecting the  $\overline{\text{ACK}}$  signal.

If the master can detect the NACK signal, the master unit enters the standby status, and communication ends. During broadcast communication, however, the master unit does not confirm the acknowledge bit, and starts outputting the telegraph length field.

The contents of the control bits are shown below.

Table 20-2. Contents of Control Bits

Bit 3 <sup>Note 1</sup>	Bit 2	Bit 1	Bit 0	Function
0	0	0	0	Read slave status
0	0	0	1	Undefined
0	0	1	0	Undefined
0	0	1	1	Read data and lock <sup>Note 2</sup>
0	1	0	0	Read lock address (lower 8 bits) <sup>Note 3</sup>
0	1	0	1	Read lock address (higher 4 bits) <sup>Note 3</sup>
0	1	1	0	Read slave status and unlock <sup>Note 2</sup>
0	1	1	1	Read data
1	0	0	0	Undefined
1	0	0	1	Undefined
1	0	1	0	Write command and lock <sup>Note 2</sup>
1	0	1	1	Write data and lock <sup>Note 2</sup>
1	1	0	0	Undefined
1	1	0	1	Undefined
1	1	1	0	Write command
1	1	1	1	Write data

**Notes 1.** The telegraph length bit of the telegraph length field and data transfer direction of the data field change as follows depending on the value of bit 3 (MSB).

If bit 3 is '1': Transfer from master unit to slave unit

If bit 3 is '0': Transfer from slave unit to master unit

**2.** This is a control bit that specifies locking or unlocking (see **20.1.7 (4) Locking and unlocking**).

**3.** The lock address is transferred in 1-byte (8-bit) units and is configured as follows:

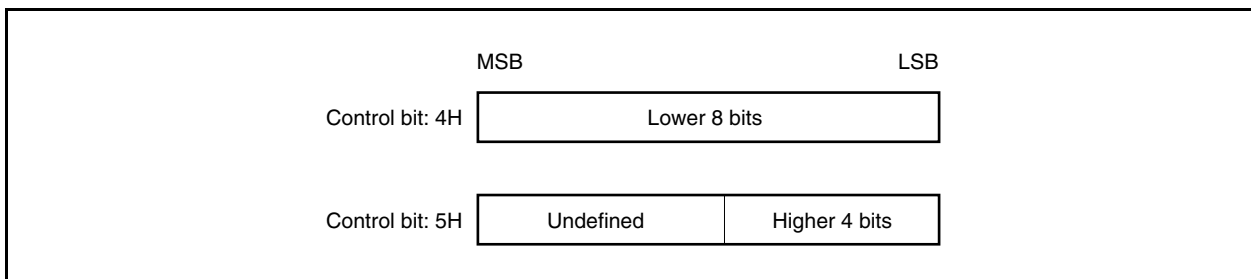

If the control bit received from the master unit is not as shown in Table 20-3, the unit locked by the master unit rejects acknowledging the control bit, and outputs the NACK signal.

**Table 20-3. Control Field for Locked Slave Unit**

Bit 3	Bit 2	Bit 1	Bit 0	Function
0	0	0	0	Read slave status
0	1	0	0	Read lock address (lower 8 bits)
0	0	0	1	Read lock address (higher 4 bits)

Moreover, units for which lock is not set by the master unit reject acknowledgment and output a NACK signal when the control data shown in Table 20-4 is acknowledged.

**Table 20-4. Control Field for Unlocked Slave Unit**

Bit 3	Bit 2	Bit 1	Bit 0	Function
0	1	0	0	Lock address read (lower 8 bits)
0	1	0	1	Lock address read (higher 4 bits)

If one unit occupies the bus as the master, the value set to the CDR register is output.

**Figure 20-4. Control Field**

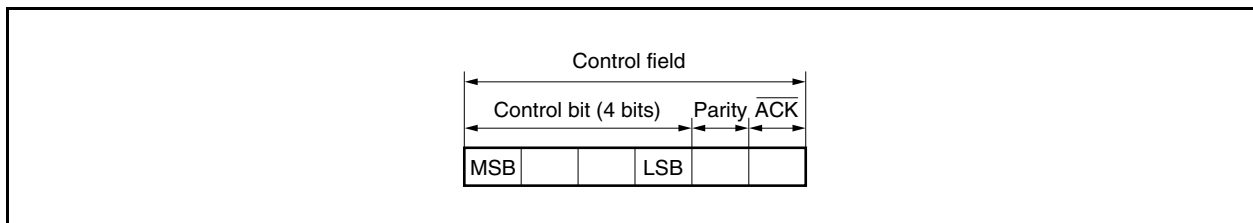

Table 20-5. Acknowledge Signal Output Condition of Control Field

## (a) If received control data is AH, BH, EH, or FH

Communication Type (USR.ALLTRANS bit) Individual Communication = 0 Broadcast Communication = 1	Communication Target (USR.SLVRQ bit) Slave Specification = 1 No Specification = 0	Lock Status (USR.LOCK bit) Lock = 1 Unlock = 0	Master Unit Identification (Match with PAR register) Lock Request Unit = 1 Other = 0	Slave Transmission Enable (BCR.ENSLVTX bit)	Slave Reception Enable (BCR.ENSLVRX bit)	Received Control Data			
						AH	BH	EH	FH
0	1	0	don't care	don't care	1	√			
		1	1						
Other than above						×			

## (b) If received control data is 0H, 3H, 4H, 5H, 6H, or 7H

Communication Type (USR.ALLTRANS bit) Individual Communication = 0 Broadcast Communication = 1	Communication Target (USR.SLVRQ bit) Slave Specification = 1 No Specification = 0	Lock Status (USR.LOCK bit) Lock = 1 Unlock = 0	Master Unit Identification (Match with PAR register) Lock Request Unit = 1 Other = 0	Slave Transmission Enable (BCR.ENSLVTX bit)	Slave Reception Enable (BCR.ENSLVRX bit)	Received Control Data					
						0H	3H	4H	5H	6H	7H
0	1	0	don't care	0	don't care	√	×	×	×	√	×
				1		√	√	×	×	√	√
		1	0	√		×	√	√	×	×	
			1	0		√	×	√	√	×	×
				1		√	√	√	√	√	√
Other than above						×					

**Caution** If the received control data is other than the data shown in Table 20-5, × (NACK signal is returned) is unconditionally assumed.

**Remark** √:  $\overline{\text{ACK}}$  signal is returned.  
×: NACK signal is returned.

**(6) Telegraph length field**

This field is output by the transmission side to inform the reception side of the number of bytes of the transmit data.

The configuration of the telegraph length field is as shown in Figure 20-5.

Table 20-6 shows the relationship between the telegraph length bit and the number of transmit data.

**Figure 20-5. Telegraph Length Field**

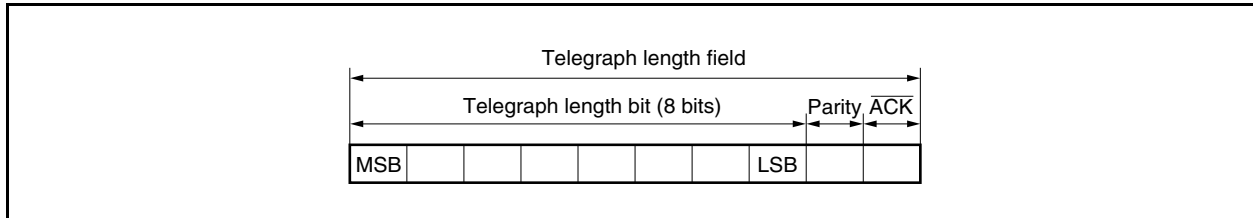

**Table 20-6. Contents of Telegraph Length Bit**

Telegraph Length Bit (Hex)	Number of Transmit Data Bytes
01H	1 byte
02H	2 bytes
FFH	255 bytes
00H	256 bytes

The operation of the telegraph length field differs depending on whether the master transmits data (when control bit 3 is 1) or receives data (when control bit 3 is 0).

**(a) When master transmits data**

The telegraph length bit and parity bit are output by the master unit and the synchronization signals of bits are output by the master unit. When the slave unit detects that the parity is even, it outputs the  $\overline{\text{ACK}}$  signal, and starts outputting the data field. During broadcast communication, however, the slave unit outputs the NACK signal.

If the parity is odd, the slave unit judges that the telegraph length bit has not been correctly received, outputs the NACK signal, and returns to the standby (monitor) status. At this time, the master unit also returns to the standby status, and communication ends.

**(b) When master receives data**

The telegraph length bit and parity bit are output by the slave unit and the synchronization signals of bits are output by the master unit. If the master unit detects that the parity bit is even, it outputs the  $\overline{\text{ACK}}$  signal.

If the parity bit is odd, the master unit judges that the telegraph length bit has not been correctly received, outputs the NACK signal, and returns to the standby status. At this time, the slave unit also returns to the standby status, and communication ends.



**(7) Data field**

This is data output by the transmission side.

The master unit transmits or receives data to or from a slave unit by using the data field.

The configuration of the data field is as shown below.

**Figure 20-6. Data Field**

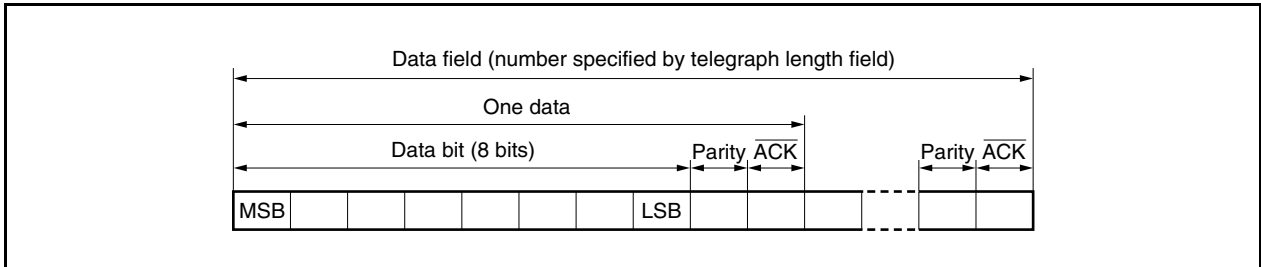

Following the data bit, the parity bit and acknowledge bit are respectively output by the master unit and slave unit.

Use broadcast communication only for when the master unit transmits data. At this time, the acknowledge bit is ignored.

The operation differs as follows depending on whether the master transmits or receives data.

**(a) When master transmits data**

When the master unit writes data to a slave unit, the master unit transmits the data bit and parity bit to the slave unit. If the parity is even and the receive data is not stored in the DR register when the slave unit has received the data bit and parity bit, the slave unit outputs an  $\overline{\text{ACK}}$  signal. If the parity is odd or if the receive data is stored in the DR register, the slave unit rejects receiving the data, and outputs the NACK signal.

If the slave unit outputs the NACK signal, the master unit transmits the same data again. This operation continues until the master detects the  $\overline{\text{ACK}}$  signal from the slave unit, or the data exceeds the maximum number of transmit bytes.

If there is more data and the maximum number of transmit bytes is not exceeded when the parity is even and when the slave unit outputs the  $\overline{\text{ACK}}$  signal, the master unit transmits the next data.

During broadcast communication, the slave unit outputs the NACK signal, and the master unit transfers 1 byte of data at a time. If the parity is odd or the DR register is storing receive data after the slave unit has received the data bit and parity bit during broadcast communication, the slave unit judges that reception has not been performed correctly, and stops reception.

**(b) When master receives data**

When the master unit reads data from a slave unit, the master unit outputs a sync signal corresponding to all the read bits.

The slave unit outputs the contents of the data and parity bits to the bus in response to the sync signal from the master unit.

The master unit reads the data and parity bits output by the slave unit, and checks the parity.

If the parity is odd, or if the DR register is storing a receive data, the master unit rejects accepting the data, and outputs the NACK signal. If the maximum number of transmit bytes is within the value that can be transmitted in one communication frame, the master unit repeats reading the same data.

If the parity is even and the DR register is not storing a receive data, the master unit accepts the data and outputs the  $\overline{\text{ACK}}$  signal. If the maximum number of transmit bytes is within the value that can be transmitted in one frame, the master unit reads the next data.

**Caution Do not operate master reception in broadcast communication, because the slave unit cannot be defined and data transfer cannot be performed correctly.**

**(8) Parity bit**

The parity bit is used to check to see if the transmit data has no error.

The parity bit is appended to each data of the master address, slave address, control, telegraph length, and data bits.

The parity is an even parity. If the number of bits in data that are '1' is odd, the parity bit is '1'. If the number of bits in the data that are '1' is even, the parity bit is '0'.

**(9) Acknowledge bit**

During normal communication (communication from one unit to another), an acknowledge bit is appended to the following locations to check if the data has been correctly received.

- End of slave address field
- End of control field
- End of telegraph length field
- End of data field

The definition of the acknowledge bit is as follows.

- 0: Indicates that the transmit data is recognized ( $\overline{\text{ACK}}$  signal).
- 1: Indicates that the transmit data is not recognized (NACK signal).

During broadcast communication, however, the contents of the acknowledge bit are ignored.

**(a) Last acknowledge bit of slave field**

The last acknowledge bit of the slave field serves as a NACK signal in any of the following cases, and transmission is stopped.

- If the parity of the master address bit or slave address bit is incorrect
- If a timing error (error in bit format) occurs
- If a slave unit does not exist

**(b) Last acknowledge bit of control field**

The last acknowledge bit of the control field serves as a NACK signal in any of the following cases, and transmission is stopped.

- If the parity of the control bit is incorrect
- If control bit 3 is '1' (write operation) when the slave reception enable flag (BCR.ENSLVRX bit) is not set (1)<sup>Note</sup>
- If the control bit indicates reading of data (3H or 7H) when the slave transmission enable flag (BCR.ENSLVTX bit) is not set (1)<sup>Note</sup>
- If a unit other than that has set locking requests 3H, 6H, 7H, AH, BH, EH, or FH of the control bit when locking is set
- If the control bit indicates reading of lock addresses (4H, 5H) even when locking is not set
- If a timing error occurs
- If the control bit is undefined

**Note** See 20.3 (1) IEBus control register (BCR).

**Cautions 1.** The  $\overline{\text{ACK}}$  signal is always returned when the control data of the slave status request is received, even if the ENSLVTX bit = 0.

**2.** The NACK signal is returned by the acknowledge bit in the control field when the control data for data/command writing is received, even if the ENSLVRX bit = 0. Slave reception can be disabled (communication stopped) by ENSLVRX bit only in the case of individual communication. In the case of broadcast communication, communication is maintained and the data request interrupt request signal (INTIE1) or IEBus end interrupt request signal (INTIE2) is generated.

**(c) Last acknowledge bit of telegraph length field**

The last acknowledge bit of the telegraph length field serves as a NACK signal in any of the following cases, and transmission is stopped.

- If the parity of the telegraph length bit is incorrect
- If a timing error occurs

**(d) Last acknowledge bit of data field**

The last acknowledge bit of the data field serves as a NACK signal in any of the following cases, and transmission is stopped.

- If the parity of the data bit is incorrect<sup>Note</sup>
- If a timing error occurs after the preceding acknowledge bit has been transmitted
- If the receive data is stored in the DR register and no more data can be received<sup>Note</sup>

**Note** In this case, when the communication executed is individual communication, if the maximum number of transmit bytes is within the value that can be transmitted in one frame, the transmission side executes transmission of that data field again. For broadcast communication, the transmission side does not execute transmission again, a communication error occurs on the reception side and reception stops.

20.1.7 Transfer data

(1) Slave status

The master unit can learn why the slave unit did not return the  $\overline{\text{ACK}}$  signal by reading the slave status. The slave status is determined according to the result of the last communication the slave unit has executed. All the slave units can supply information on the slave status. The configuration of the slave status is shown below.

Figure 20-7. Bit Configuration of Slave Status

MSB								LSB	
Bit 7	Bit 6	Bit 5	Bit 4	Bit 3	Bit 2	Bit 1	Bit 0		
Bit 0 <sup>Note 1</sup>		Function							
0		Transmit data is not written in DR register							
1		Transmit data is written in DR register							
Bit 1 <sup>Note 2</sup>		Function							
0		Receive data is not stored in DR register							
1		Receive data is stored in DR register							
Bit 2		Function							
0		Unit is not locked							
1		Unit is locked							
Bit 3		Function							
0		Fixed to 0							
Bit 4 <sup>Note 3</sup>		Function							
0		Slave transmission is stopped							
1		Slave transmission is ready							
Bit 5		Function							
0		Fixed to 0							
Bit 7	Bit 6	Function							
0	0	Mode 0	Indicates the highest mode supported by the unit <sup>Note 4</sup> .						
0	1	Mode 1							
1	0	Mode 2							
1	1	Not used							

- Notes 1.** After reset: Bit 0 is set to 1.
- 2.** The receive buffer size is 1 byte.
- 3.** When the V850E/SJ3-H or V850E/SK3-H serves as a slave unit, this bit corresponds to the status indicated by BCR.ENSLVTX bit.
- 4.** Bits 7 and 6 are fixed to “10” because the V850E/SJ3-H and V850E/SK3-H can support modes 1 and 2.

**(2) Lock address**

When the lock address is read (control bit: 4H or 5H), the address (12 bits) of the master unit that has issued the lock instruction is configured in 1-byte units as shown below and read.

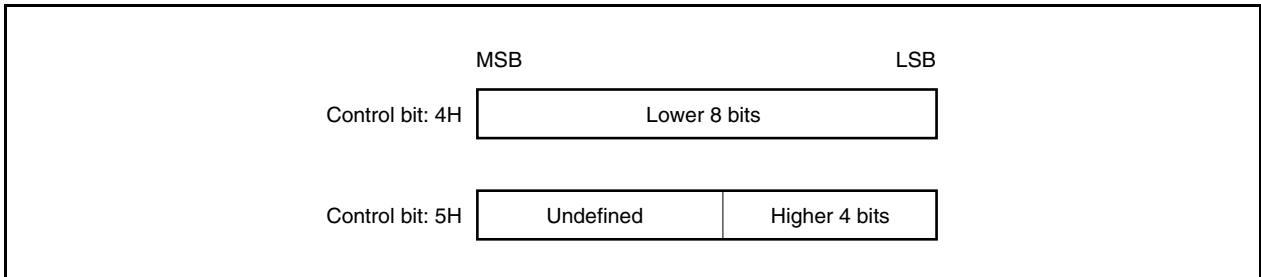
**Figure 20-8. Configuration of Lock Address****(3) Data**

If the control bit indicates reading of data (3H or 7H), the data in the data buffer of the slave unit is read by the master unit.

If the control bit indicates writing of data (BH or FH), the data received by the slave unit is processed according to the operation rule of that slave unit.

**(4) Locking and unlocking**

The lock function is used when a message is transferred in two or more communication frames.

The unit that is locked does not receive data from units other than the one that has locked the unit (does not receive broadcast communication).

A unit is locked or unlocked as follows.

**(a) Locking**

If the communication frame is completed without succeeding to transmit or receive data of the number of bytes specified by the telegraph length bit after the telegraph length field has been transmitted or received ( $\overline{\text{ACK}} = 0$ ) by the control bit that specifies locking (3H, AH, or BH), the slave unit is locked by the master unit. At this time, the bit (bit 2) in the byte indicating the slave status is set to '1'.

**(b) Unlocking**

After transmitting or receiving data of the number of data bytes specified by the telegraph length bit in one communication frame by the control bit that has specified locking (3H, AH, or BH), or the control bit that has specified unlocking (6H), the slave unit is unlocked by the master unit. At this time, the bit related to locking (bit 2) in the byte indicating the slave status is reset to '0'.

Locking or unlocking is not performed during broadcast communication.

Locking and unlocking conditions are shown below.

**Table 20-7. Lock Setting Conditions**

Control Data	Broadcast Communication		Individual Communication	
	Communication End	Frame End	Communication End	Frame End
3H, 6H <sup>Note</sup>	/		Cannot be locked	Lock set
AH, BH	Cannot be locked	Cannot be locked	Cannot be locked	Lock set
0H, 4H, 5H, EH, FH	Cannot be locked	Cannot be locked	Cannot be locked	Cannot be locked

**Note** The frame end of control data 6H (slave status read/unlock) occurs when the parity in the data field is odd, and when the NACK signal from the IEBus unit is repeated up to the maximum number of transfer bytes with being output.

**Table 20-8. Unlock Release Conditions (While Locked)**

Control Data	Broadcast Communication from Lock Request Unit		Individual Communication from Lock Request Unit	
	Communication End	Frame End	Communication End	Frame End
3H, 6H <sup>Note</sup>	/		Unlocked	Remains locked
AH, BH	Unlocked	Unlocked	Unlocked	Remains locked
0H, 4H, 5H, EH, FH	Remains locked	Remains locked	Remains locked	Remains locked

**Note** The frame end of control data 6H (slave status read/unlock) occurs when the parity in the data field is odd, and when the NACK signal from the IEBus unit is repeated up to the maximum number of transfer bytes with being output.

**20.1.8 Bit format**

The format of the bits constituting the communication frame of the IEBus is shown below.

**Figure 20-9. Bit Format of IEBus**

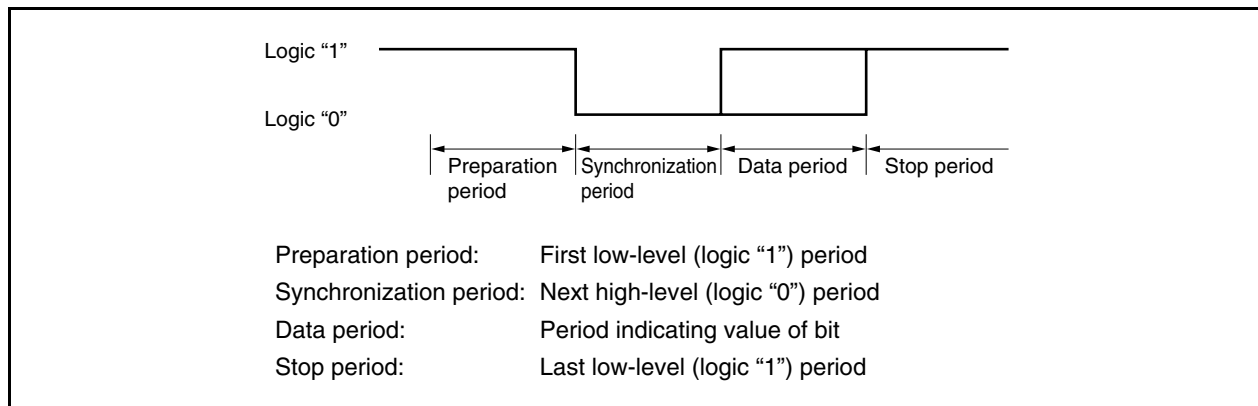

The synchronization period and data period are almost equal to each other in length.

The IEBus synchronizes each bit. The specifications on the time of the entire bit and the time related to the period allocated to that bit differ depending on the type of the transmit bit, or whether the unit is the master unit or a slave unit.

The master and slave units monitor whether each period (preparation period, synchronization period, data period, and stop period) is output for specified time while they are in communication. If a period is not output for the specified time, the master and slave units report a timing error, immediately terminate communication and enter the standby status.

## 20.2 Configuration

The block diagram of the IEBus controller is shown below.

Figure 20-10. IEBus Controller Block Diagram

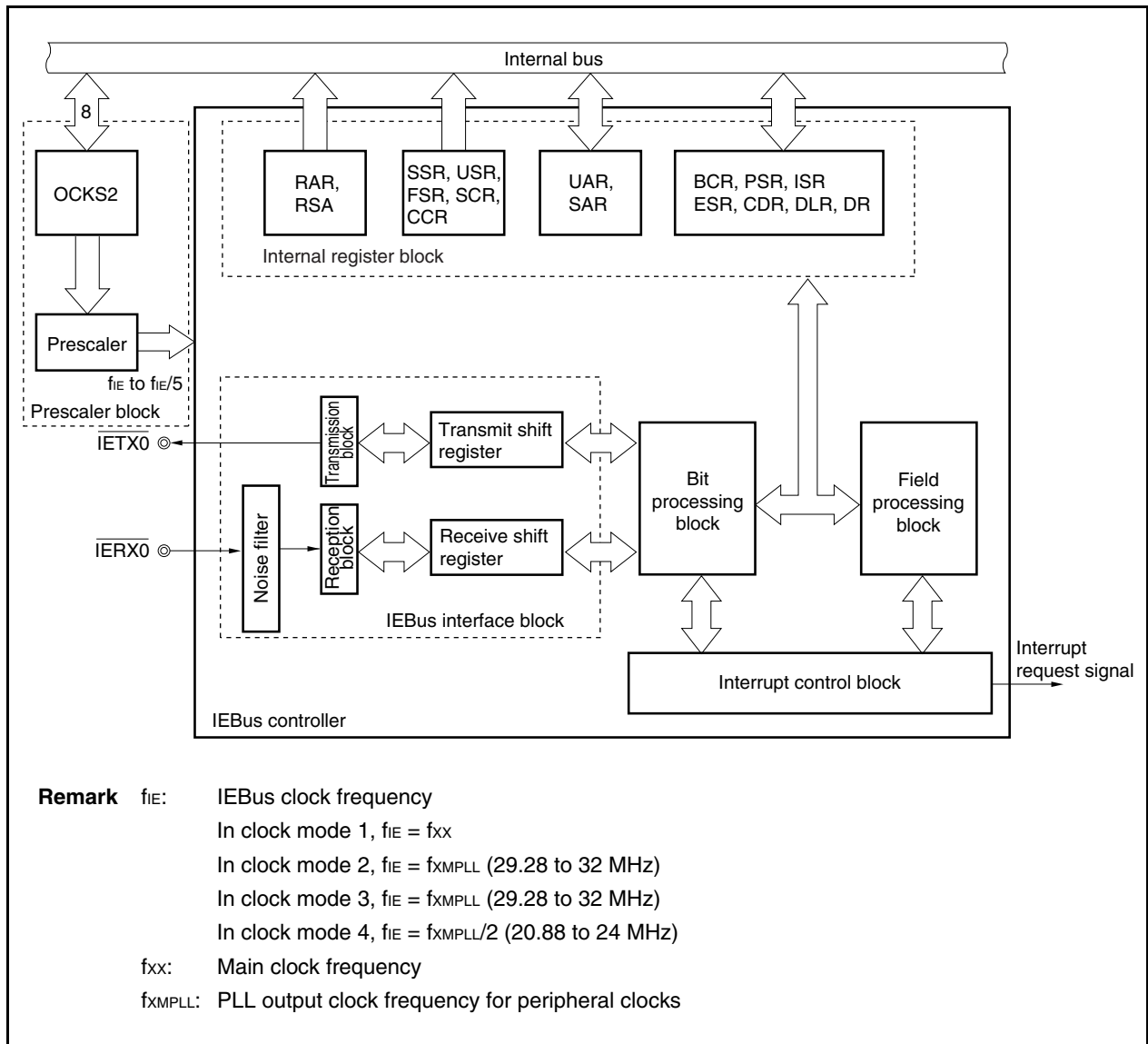

### (1) Hardware configuration and functions

IEBus mainly consists of the following six internal blocks.

- Interrupt control block
- Internal registers
- Bit processing block
- Field processing block
- IEBus interface block
- Prescaler block

**(a) Interrupt control block**

This control block transfers interrupt request signals from the IEBus controller to the CPU.

**(b) Internal registers**

These registers set data to the control registers and fields that control IEBus (for the internal registers, see **20.3 Registers**).

**(c) Bit processing block**

This block generates and breaks down bit timing, and mainly consists of a bit sequence ROM, 8-bit preset timer, and comparator.

**(d) Field processing block**

This block generates each field in the communication frame, and mainly consists of a field sequence ROM, 4-bit down counter, and comparator.

**(e) IEBus interface block**

This is the interface block for an external driver/receiver, and mainly consists of a noise filter, shift register, and transmission/reception block (collision detector, parity detector, parity generator, and ACK/NACK generator).

**(f) Prescaler block**

This block selects the clock to be supplied to the IEBus controller.



## 20.3 Registers

The registers that control the IEBus controller are shown below.

**Table 20-9. Control Registers of IEBus Controller**

Address	Function Register Name	Symbol	R/W	Bit Unit for Manipulation			After Reset
				1	8	16	
FFFFFF348H	IEBus clock select register	OCKS2	R/W		√		00H
FFFFFF360H	IEBus control register	BCR		√	√		
FFFFFF361H	IEBus power save register	PSR		√	√		
FFFFFF362H	IEBus slave status register	SSR	R	√	√		81H
FFFFFF363H	IEBus unit status register	USR		√	√		00H
FFFFFF364H	IEBus interrupt status register	ISR	R/W	√	√		0000H
FFFFFF365H	IEBus error status register	ESR		√	√		
FFFFFF366H	IEBus unit address register	UAR				√	
FFFFFF368H	IEBus slave address register	SAR			√		
FFFFFF36AH	IEBus partner address register	PAR	R			√	0000H
FFFFFF36CH	IEBus receive slave address register	RSA				√	
FFFFFF36EH	IEBus control data register	CDR	R/W		√		00H
FFFFFF36FH	IEBus telegraph length register	DLR			√		01H
FFFFFF370H	IEBus data register	DR			√		00H
FFFFFF371H	IEBus field status register	FSR	R		√		01H
FFFFFF372H	IEBus success count register	SCR			√		
FFFFFF373H	IEBus communication count register	CCR			√		

**(1) IEBus control register (BCR)**

The BCR register is an 8-bit register that controls the operations of the IEBus controller.

This register can be read or written in 8-bit or 1-bit units.

Reset sets this register to 00H.

After reset: 00H R/W Address: FFFFF360H

	<7>	<6>	<5>	<4>	<3>	2	1	0
BCR	ENIEBUS	MSTRQ	ALLRQ	ENSLVTX	ENSLVRX	0	0	0

ENIEBUS	Communication enable flag
0	IEBus unit stopped
1	IEBus unit active

MSTRQ	Master request flag
0	IEBus unit not requested as master
1	IEBus unit requested as master

ALLRQ	Broadcast request flag
0	Individual communication requested
1	Broadcast communication requested

ENSLVTX	Slave transmission enable flag
0	Slave transmission disabled
1	Slave transmission enabled

ENSLVRX	Slave reception enable flag
0	Slave reception disabled
1	Slave reception enabled

**Cautions 1.** While IEBus is operating as the master, writing to the BCR register (including bit manipulation instructions) is disabled until either the end of that communication or frame, or until communication is stopped by the occurrence of an arbitration-loss communication error. Master requests cannot therefore be multiplexed. However, the case when communication has been forcibly stopped (ENIEBUS flag = 0) is not problem.

**2.** If a bit manipulation instruction for the BCR register conflicts with a hardware reset of the MSTRQ bit, the BCR register may not operate normally. The following countermeasures are recommended in this case.

- Because the hardware reset is instigated in the acknowledgment period of the slave address field, be sure to observe Caution 1 of (b) Master request flag (MSTRQ) below.
- Be sure to observe the caution above regarding writing to the BCR register.

**3.** Be sure to set bits 0 to 2 to “0”.

**(a) Communication enable flag (ENIEBUS)...Bit 7**

<Set/clear conditions>

Set: By software

Clear: By software

The IEBus controller participates in communication differently depending on the timing of setting the ENIEBUS bit (1), as follows.

**Table 20-10. Timing of Setting ENIEBUS Bit and Participation in Communication**

Timing of Setting ENIEBUS Bit	How IEBus Controller Participates in Communication
If communication is not performed on IEBus	Participates in communication from the next frame or starts communication.
If other bus master is communicating start bit while communication is in progress on IEBus	Participates in communication from that frame if the start bit is detected. If the start bit is not detected, participates in communication from the next frame.
If communication is in progress on IEBus after start bit from other bus master is detected	Participates in communication from the next frame.

If the ENIEBUS bit is cleared (0), communication is immediately stopped even while it is in progress, and the internal flags and registers are reset, with some exceptions. The registers that are not reset by the ENIEBUS bit are listed in the table below.

The IEBus controller does not respond even if another unit starts communication when the ENIEBUS bit = 0.

**Table 20-11. Registers That Are Not Reset by ENIEBUS Bit**

Registers Not Reset by ENIEBUS Bit	Remark
UAR	Not reset
SAR	Not reset
CDR	Data written from CPU is not reset but data received during communication is reset.
DLR	Data written from CPU is not reset but data received during communication is reset.
DR	Data written from CPU is not reset but data received during communication is reset.

**Caution** Before setting the ENIEBUS bit (1), the following registers must be set depending on the mode of communication to be started.

**Table 20-12. Registers That Must Be Set Before Each Communication**

Mode of Communication	Registers That Must Be Set in Advance
Master transmission	UAR, SAR, CDR, DLR, DR (first 1-byte data)
Master reception	UAR, SAR, CDR
Slave transmission <sup>Note</sup>	UAR, DLR, DR (first 1-byte data) <sup>Note</sup>
Slave reception	UAR

**Note** When starting slave transmission, information such as the value to be set to the DLR register and which data is to be returned (value to be set to the DR register) must be assigned in advance.

**(b) Master request flag (MSTRQ)...Bit 6**

&lt;Set/clear conditions&gt;

Set: By software

Clear: Cleared (0) by hardware when master communication is started and immediately before the start interrupt of the master occurs.

Cleared (0) by hardware before a communication error occurs.

When the ENIEBUS bit is cleared.

When the MSTRQ bit is set (1), the IEBus controller starts communication on IEBus as the master.

If communication is in progress on IEBus (if the start bit cannot be detected while the start bit is being communicated or if communication is in progress after the start bit has been detected), however, the controller waits until the current frame ends (holds the master request pending), outputs the start bit after the frame has ended, and starts communication as the master.

**Cautions 1. If the IEBus controller has lost in arbitration, issue the master request again by software.**

**In doing so, set (1) the MSTRQ bit at a timing other than that illustrated below.**

**Figure 20-11. Timing at Which MSTRQ Bit Cannot Be Set**

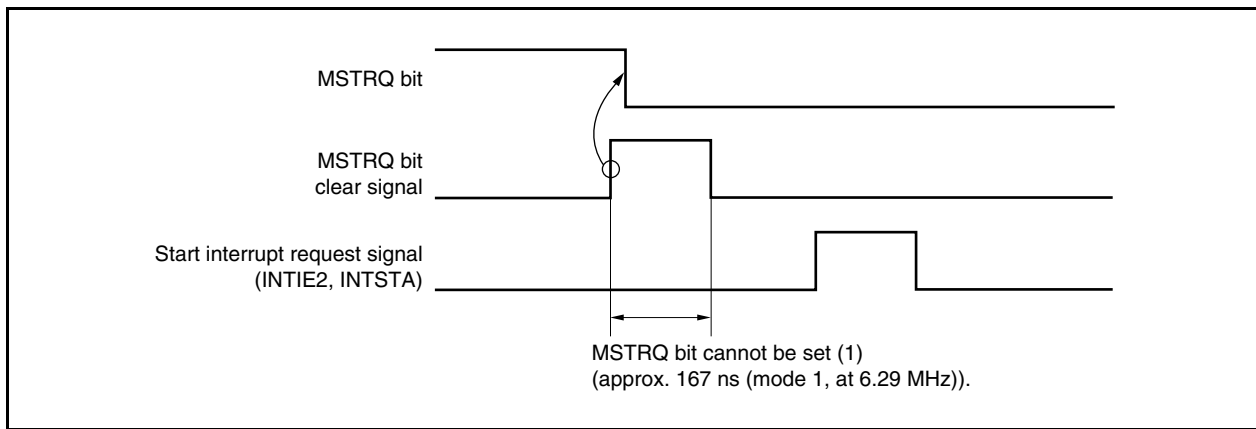

2. When a master request has been sent and bus mastership acquired, do not set the MSTRQ, ENSLVTX, or ENSLVRX bit until the end of communication (i.e. the communication end flag (ISR.ENDTRNS bit) or frame end flag (ISR.ENDFRAM bit) is set (1)) as setting these flags disables interrupt request signal generation. However, these flags can be set if communication has been aborted.

**(c) Broadcast request flag (ALLRQ)...Bit 5**

&lt;Set/clear conditions&gt;

Set: By software

Clear: By software

**Caution** When requesting broadcast communication, always set (1) the ALLRQ bit, then the MSTRQ bit.

**(d) Slave transmission enable flag (ENSLVTX)...Bit 4**

&lt;Set/clear conditions&gt;

Set: By software

Clear: By software

- Cautions**
1. The ENSLVTX bit must be set before the parity bit in the control field is received.
  2. Clear the ENSLVTX bit (0) before setting the MSTRQ bit (1) when making a master request. This is to avoid transmission of the data of the DR register that tries master transmission if the controller loses in arbitration after master operation and if slave transmission is requested by the master.
  3. When returning to an enabled state from a disabled state, transmission becomes valid from the next frame.
  4. If control data (3H or 7H) for data/command writing is received when the ENSLVTX bit = 0, the NACK signal is returned by the acknowledge bit in the control field.
  5. The status interrupt request signals (INTIE2, INTSTA) will be generated and communication continued when the control data of a slave status request is returned, even if the ENSLVTX bit = 0.

**(e) Slave reception enable flag (ENSLVRX)...Bit 3**

&lt;Set/clear conditions&gt;

Set: By software

Clear: By software

- Cautions**
1. The ENSLVRX bit must be set before the parity bit in the control field is received.
  2. While the CPU is busy with other processing, slave reception can be prevented by clearing the ENSLVRX bit (0). During individual communication, the NACK signal is returned in the control field and communication is completed. During broadcast communication, communication cannot be completed because the acknowledge bit is ignored. However, the IEBus controller does not respond to the broadcast communication and does not generate an interrupt request signal.
  3. When returning to an enabled state from a disabled state, transmission becomes valid from the next frame.

**(2) IEBus power save register (PSR)**

The PSR register is an 8-bit register that controls the internal clock and communication mode of the IEBus controller.

This register can be read or written in 8-bit or 1-bit units.

Reset sets this register to 00H.

After reset: 00H R/W Address: FFFFF361H

	<7>	<6>	5	4	3	2	1	0
PSR	ENCLK	IEMODE	0	0	0	0	0	0

ENCLK	Internal clock operation enable flag
0	Stop internal clock of IEBus controller
1	Enable internal clock of IEBus controller

IEMODE	IEBus communication mode setting flag
0	Set communication mode 1
1	Set communication mode 2

- Cautions**
1. Do not set the PSR register while communication is enabled (BCR.ENIEBUS bit = 1).
  2. Be sure to clear bits 5 to 0 to "0".

**(3) IEBus slave status register (SSR)**

The SSR register is an 8-bit register that indicates the communication status of the slave unit. After receiving a slave status transmission request from the master, read this register by software, and write a slave status to the DR register to transmit the slave status. At this time, the telegraph length is automatically set to “01H”, so setting of the DLR register is not required (because it is preset by hardware).

Bits 6 and 7 indicate the highest mode supported by the unit, and are fixed to “10” (mode 2).

This register is read-only, in 8-bit or 1-bit units.

Reset sets this register to 81H.

After reset: 81H R		Address: FFFFF362H						
	7	6	5	<4>	3	<2>	<1>	<0>
SSR	1	0	0	STATSLV	0	STATLOCK	STATRX	STATTX
	STATSLV Slave transmission status flag							
	0	Slave transmission stops						
	1	Slave transmission enabled						
	STATLOCK Lock status flag							
	0	Unlock status						
	1	Lock status						
	STATRX DR register receive status							
	0	Receive data not stored in DR register						
	1	Receive data stored in DR register						
	STATTX DR register transmit status							
	0	Transmit data not stored in DR register						
	1	Transmit data stored in DR register						

**(a) Slave transmission status flag (STATSLV)...Bit 4**

Reflects the contents of the slave transmission enable flag (BCR.ENSLVTX bit).

**(b) Lock status flag (STATLOCK)...Bit 2**

Reflects the contents of the lock flag (USR.LOCK bit).

**(c) DR register reception status (STATRX)...Bit 1**

This flag indicates the DR register reception state.

**(d) DR register transmission status (STATTX)...Bit 0**

This flag indicates the DR register transmission state.

**(4) IEBus unit status register (USR)**

The USR register is an 8-bit register that indicates the IEBus unit status.

This register is read-only, in 8-bit or 1-bit units.

Reset sets this register to 00H.

After reset: 00H R Address: FFFF363H

	7	<6>	<5>	<4>	<3>	2	1	0
USR	0	SLVRQ	ARBIT	ALLTRNS	ACK	LOCK	0	0

SLVRQ	Slave request flag
0	No request from master to slave
1	Request from master to slave

ARBIT	Arbitration result flag
0	Arbitration loss not occurred
1	Arbitration loss occurred

ALLTRNS	Broadcast communication flag
0	Individual communication status
1	Broadcast communication status

ACK	Acknowledge transmission flag
0	NACK signal transmitted
1	$\overline{\text{ACK}}$ signal transmitted

LOCK	Lock status flag
0	Unit unlocked
1	Unit locked

**Caution** Be sure to set bits 0, 1, and 7 to “0”.



**(a) Slave request flag (SLVRQ)...Bit 6**

A flag indicating whether there has been a slave request from the master.

<Set/clear conditions>

**Set:** When the unit is requested as a slave (if the condition in **Table 20-13 Slave Request Condition (SLVRQ Bit Setting Condition)** is satisfied), this flag is set (1) by hardware when the acknowledge period of the slave address field starts.

**Clear:** This flag is cleared (0) by hardware when the unit is not requested as a slave (if the condition in **Table 20-13 Slave Request Condition (SLVRQ Bit Setting Condition)** is not satisfied). The reset timing is the same as the set timing. If the unit is requested as a slave immediately after communication has been correctly received (when the SLVRQ bit = 1), and if a parity error occurs in the slave address field for that communication, the flag is not cleared.

**Table 20-13. Slave Request Condition (SLVRQ Bit Setting Condition)**

Status of Unit	Received Master Address	Communication Mode	Received Slave Address
Not locked	don't care	Individual	UAR register matching
		Broadcast	Group matching
			FFFH
Locked	Locked master matching	Individual	UAR register matching
		Broadcast	Group matching
			FFFH

**Caution** If a unit other than the locked master communicates with the unit while the unit is locked, the SLVRQ bit is not set but the  $\overline{\text{ACK}}$  signal is returned to the slave address field. This is because communication must be continued, even if a unit other than the locked master returns the signal, if the control data is a slave status request.

**(b) Arbitration result flag (ARBIT)...Bit 5**

A flag that indicates the result of arbitration.

<Set/clear conditions>

**Set:** This flag is set (1) when the data output by the IEBus unit during the arbitration period does not match the bus line data.

**Clear:** This flag is cleared (0) by the start bit timing.

**Cautions 1.** The timing at which the arbitration result flag (ARBIT bit) is cleared differs depending on whether the unit outputs a start bit.

- **If start bit is output:** The flag is cleared at the output start timing.
- **If start bit is not output:** The flag is cleared at the detection timing of the start bit (approx. 160  $\mu\text{s}$  (mode 1, at 6.29 MHz) after output)

**2.** The flag is cleared (0) at the detection timing of the start bit if the other unit outputs the start bit earlier and the unit does not output the start bit after the master request.

**(c) Broadcast communication flag (ALLTRNS)...Bit 4**

Flag indicating whether the unit is performing broadcast communication. The contents of the flag are updated in the broadcast field of each frame.

Except for initialization (reset) by system reset, the set/clear conditions vary depending on the receive data of the broadcast field bit.

<Set/clear conditions>

Set: When "broadcast" is received by the broadcast field

Clear: When "individual" is received by the broadcast field, or upon the input of a system reset.

**Caution** The broadcast flag is updated regardless of whether IEBus is the communication target or not.

**Figure 20-12. Example of Broadcast Communication Flag Operation**

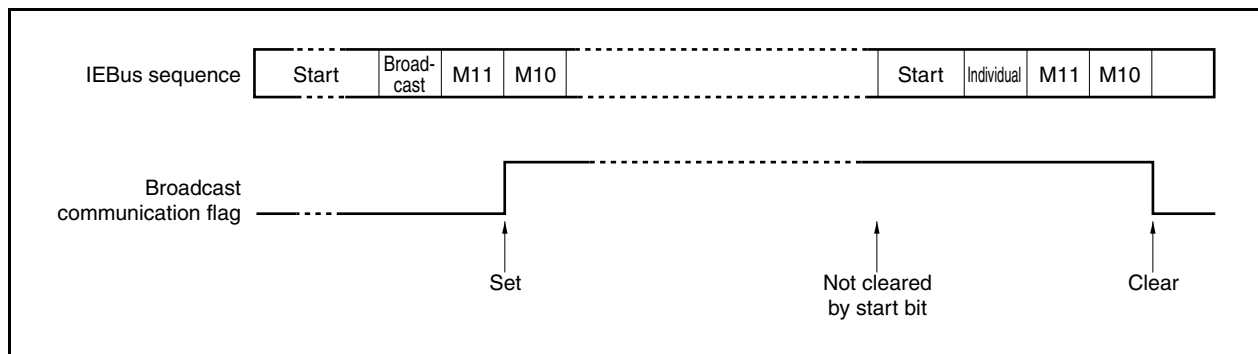
**(d) Acknowledge transmission flag (ACK)...Bit 3**

A flag that indicates whether the  $\overline{\text{ACK}}$  signal has been transmitted in the acknowledge bit period of the acknowledge bit field when IEBus is the receiving unit. The contents of the flag are updated in the acknowledge bit period of each frame. However, if the internal circuit is initialized by the occurrence of a parity error, etc., the contents are not updated in the acknowledge bit period of that field.

**(e) Lock status flag (LOCK)...Bit 2**

A flag that indicates whether the unit is locked.

<Set/clear conditions>

Set: This flag is set (1) when the communication end flag (ISR.ENDTRNS bit) goes low and the frame end flag (ISR.ENDFRAM bit) goes high after receipt of a lock specification (3H, 6H, AH, BH) in the control field.

Clear: When the communication enable flag (BCR.ENIEBUS bit) is cleared (0).

When the communication end flag (ENDTRNS bit) is set (1) after receipt of a lock release (3H, 6H, AH, BH) in the control field.

**Caution** Lock specification/release is not possible in broadcast communication. In the lock status, individual communication from a unit other than the one that requests locking is not acknowledged. However, even communication from a unit other than the one that requests locking is acknowledged as long as the communication is a slave status request.

**(5) IEBus interrupt status register (ISR)**

The ISR register indicates the interrupt source when IEBus issues an interrupt request signal. This register is read to generate an interrupt request signal, after which the specified interrupt servicing is carried out. This register can be read or written in 8-bit or 1-bit units. Reset sets this register to 00H.

After reset: 00H    R/W<sup>Note 1</sup>    Address: FFFF364H

	7	<6>	<5>	<4>	<3>	<2>	1	0
ISR	0	IEERR	STARTF	STATUSF	ENDTRNS	ENDFRAM	0	0

IEERR	Communication error flag (during communication)
0	No communication error
1	Communication error

STARTF	Start interrupt flag
0	Start interrupt request signal did not occur
1	Start interrupt request signal occurred

STATUSF	Status transmission flag (slave)
0	No slave status/lock address (higher 4 bits, lower 8 bits) transmission request
1	Slave status/lock address (higher 4 bits, lower 8 bits) transmission request

ENDTRNS	Communication end flag
0	Communication does not end after the number of bytes set in the telegraph length field have been transferred
1	Communication ends after the number of bytes set in the telegraph length field have been transferred

ENDFRAM	Frame end flag
0	The frame (transfer of the maximum number of bytes <sup>Note 2</sup> ) does not end
1	The frame (transfer of the maximum number of bytes <sup>Note 2</sup> ) ends

**Notes 1.** Only the IEERR bit can be written, and only to 0 (i.e., the IEERR bit can only be cleared). The IEERR bit is not set (1) even if 1 is written to it.

- 2. Mode 1: 32 bytes
- Mode 2: 128 bytes

**Caution** Be sure to set bits 0, 1, and 7 to “0”.

**(a) Communication error flag (IEERR)...Bit 6**

A flag that indicates a communication error has occurred. When a communication error occurs, the INTIE2 and INTERR interrupt request signals are generated.

<Set/clear conditions>

Set: The flag is set (1) if a timing error, parity error (except in the data field), NACK reception error (except in the data field), underrun error, overrun error (that occurs during broadcast communication reception), or write error occurs.

Clear: By software

**(b) Start interrupt flag (STARTF)...Bit 5**

A flag that indicates the start interrupt. When a start interrupt occurs, the INTIE2 and INTSTA interrupt request signals are generated.

<Set/clear conditions>

Set: This flag is set (1) in the slave address field, upon a master request.

When IEBus is a slave unit, this flag is set (1) upon a request from the master (only if it was a slave request in the locked state from the unit requesting a lock).

Clear: This flag is cleared (0) if the status transmission interrupt, communication end interrupt, frame end interrupt, or INTIE1 interrupt request signal is generated.

**(c) Status transmission flag (STATUSF)...Bit 4**

A flag that indicates the master requested transmission of the slave status and lock address (higher 4 bits and lower 8 bits) when the controller was serving as a slave.

<Set/clear conditions>

Set: This flag is set (1) when 0H, 4H, 5H, or 6H is received in the control field from the master when the IEBus is a slave unit.

Clear: This flag is cleared (0) if the start interrupt, communication end interrupt, frame end interrupt, or INTIE1 interrupt request signal is generated.

**(d) Communication end flag (ENDTRANS)...Bit 3**

A flag that indicates whether communication ends after the number of bytes set in the telegraph length field have been transferred. When a communication error occurs, the INTIE2 and INTSTA interrupt request signals are generated.

<Set/clear conditions>

Set: This flag is set (1) when the count value of the SCR register is 00H.

Clear: This flag is cleared (0) if the start interrupt, status transmission interrupt, frame end interrupt (if the communication end interrupt does not occur), or INTIE1 interrupt request signal is generated.

**(e) Frame end flag (ENDFRAM)...Bit 2**

A flag that indicates whether communication ends after the maximum number of bytes (mode 1: 32 bytes, mode 2: 128 bytes) have been transferred.

<Set/clear conditions>

Set: This flag is set (1) when the count value of the CCR register is 00H.

Clear: This flag is cleared (0) if the start interrupt, status transmission interrupt, communication end interrupt (if the frame end interrupt does not occur), or INTIE1 interrupt request signal is generated

**Cautions 1. If both the CCR and SCR registers are cleared to 00H, the ENDTRNS and ENDFRAM bits are set (1) at the same time.**

**2. If the last data field is the NACK signal when the maximum number of transmitted bytes is reached as a result of retransmitting the data, the ENDFRAM bit and IEERR (NACK reception error) bit are set at the same time.**

**(6) IEBus error status register (ESR)**

The ESR register indicates the source of the communication error interrupt request signal of IEBus. Each bit of this register is set (1) as soon as the communication error flag (ISR.IEERR bit) is set (1). The source of a communication error, if any, can be identified by checking the contents of this register.

This register can be read or written in 8-bit or 1-bit units.

Reset sets this register to 00H.

After reset: 00H R/W Address: FFFFF365H

	<7>	<6>	<5>	<4>	<3>	<2>	1	<0>
ESR	TERR	PERR	NERR	UERR	OERR	WERR	0	DEFLAG

TERR	Timing error occurrence flag
0	Timing error did not occur
1	Timing error occurred

PERR	Parity error occurrence flag
0	Parity error did not occur
1	Parity error occurred

NERR	NACK reception error occurrence flag
0	NACK reception error does not occur
1	NACK reception error occurred

UERR	Underrun error occurrence flag
0	Underrun error did not occur
1	Underrun error occurred

OERR	Overrun error occurrence flag
0	Overrun error did not occur
1	Overrun error occurred

WERR	Write error occurrence flag
0	Write error did not occur
1	Write error occurred

DEFLAG	Third party error occurrence flag
0	Error occurred during communication with unit
1	Error occurred during communication with station other than unit

- Cautions**
1. Each bit can only be cleared (0). It cannot be set (1) even if 1 is written to it.
  2. The value of the ESR register is updated when an error occurs. If the ESR register is read at this time, however, an undefined value is read. It is recommended to read the ESR register in error interrupt servicing.
  3. If a communication error occurs, the IEBus controller returns to the default status and makes preparation for communication. If communication is started without the error corrected, the error flag accumulates the error. Correct the error before the next communication is started.
  4. Be sure to set bit 1 to "0".

**(a) Timing error occurrence flag (TERR)...Bit 7**

&lt;Set/clear conditions&gt;

Set: This flag is set (1) if a timing error occurs.

Clear: By software

A timing error occurs if the high-/low-level width of the communication bit is not the defined value. The defined value of the high- and low-level width is set to the bit processing block and monitored by the internal timer. If a timing error occurs, the INTERR and INTIE2 interrupt request signals are generated.

**(b) Parity error occurrence flag (PERR)...Bit 6**

&lt;Set/clear conditions&gt;

Set: This flag is set (1) if a parity error occurs.

Clear: By software

A parity error occurs if the parity generated in each field does not match the received parity while the controller is serving as a receiver unit. If the parity does not match in the data field during individual communication, however, the NACK signal is returned and retransmission of data is requested. Therefore, the parity error does not occur.

**Table 20-14. Operation if Parity Does Not Match**

Field	Communication Mode	Operation if Parity Does Not Match
Master address field	Individual/broadcast	Parity error occurs.
Slave address field	Individual/broadcast	Parity error occurs.
Control data field	Individual/broadcast	Parity error occurs.
Telegraph length field	Individual/broadcast	Parity error occurs.
Data field	Individual	Retransmission is requested by returning NACK signal.
	Broadcast	Parity error occurs.

**(c) NACK reception error occurrence flag (NERR)...Bit 5**

&lt;Set/clear conditions&gt;

Set: This flag is set (1) if a NACK reception error occurs.

Clear: By software

A NACK reception error occurs if the NACK signal is received during the acknowledge bit period of the slave address field, control data field, or telegraph length field during individual communication, regardless of whether the controller is operating as the master or a slave. If the NACK signal is received during the acknowledge bit period of the data field, a NACK reception error does not occur because data is retransmitted. If the NACK signal is received during the acknowledge period of the last data field when the maximum number of transfer bytes is reached, the NACK reception error occurs.

The NACK reception error does not occur during broadcast communication because the  $\overline{\text{ACK/NACK}}$  signal is not identified.

The NACK reception error does not occur during third-party communication because only the timing/parity error is detected as an error.

**(d) Underrun error occurrence flag (UERR) ... Bit 4**

&lt;Set/clear conditions&gt;

Set: This flag is set (1) if an underrun error occurs.

Clear: By software

An underrun error occurs if the next data is not transmitted to the DR register in time before the  $\overline{\text{ACK}}$  signal is received. If the NACK signal is received during individual communication and during the acknowledge bit period, the underrun error does not occur because the data is retransmitted.

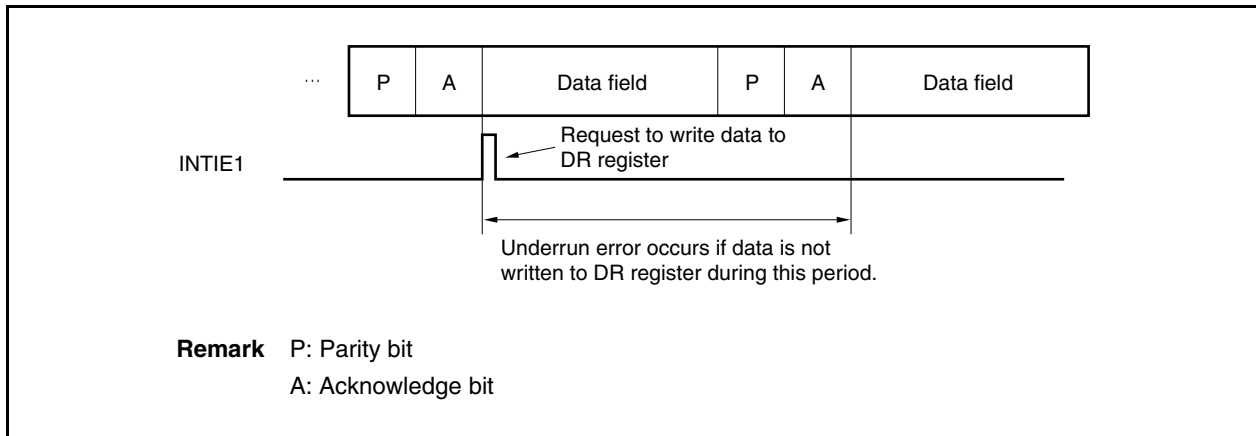
**Figure 20-13. Timing of Underrun Error Occurrence**



**(e) Overrun error occurrence flag (OERR) ... Bit 3**

&lt;Set/clear conditions&gt;

Set: This flag is set (1) if an overrun error occurs.

Clear: By software

If 1-byte data is stored in the DR register while the IEBus controller serves as a receiver unit, the data request interrupt request signal (INTIE1) is generated, and the DR register is read by means of DMA or by software. If this reading is delayed and the next data is received, an overrun error occurs.

- Cautions 1.** If the DR register is not read and the number of retransmitted data reaches the maximum number of transmitted bytes (32 bytes) after the overrun error has occurred, the frame end interrupt request signal (INTSTA or INTIE2) occurs. The overrun status is maintained until the DR register is read, even after the frame has ended.
- 2.** The overrun status is cleared only when the DR register is read and when the system is reset. Therefore, be sure to read the DR register in the communication error interrupt servicing program.
- 3.** The next data cannot be transmitted in the overrun status if it is 2 bytes or more. Because the data request interrupt request signal (INTIE1) does not occur, the transmit data cannot be set and an underrun error occurs. Therefore, be sure to execute transmission after clearing the overrun status.

**Remark** During individual communication reception, the NACK signal is returned during the acknowledge bit period of the next data. In response, the transmitter unit retransmits data. Therefore, the CCR register is decremented but the SCR register is not decremented. During broadcast communication reception, the communication error interrupt request signal (INTIE2) is generated and reception is stopped. At this time, the DR register is not updated. The INTIE1 signal is not generated. The STATRX bit of the SSR register is held set (to 1). The overrun status is cleared when data is received after the DR register has been read.

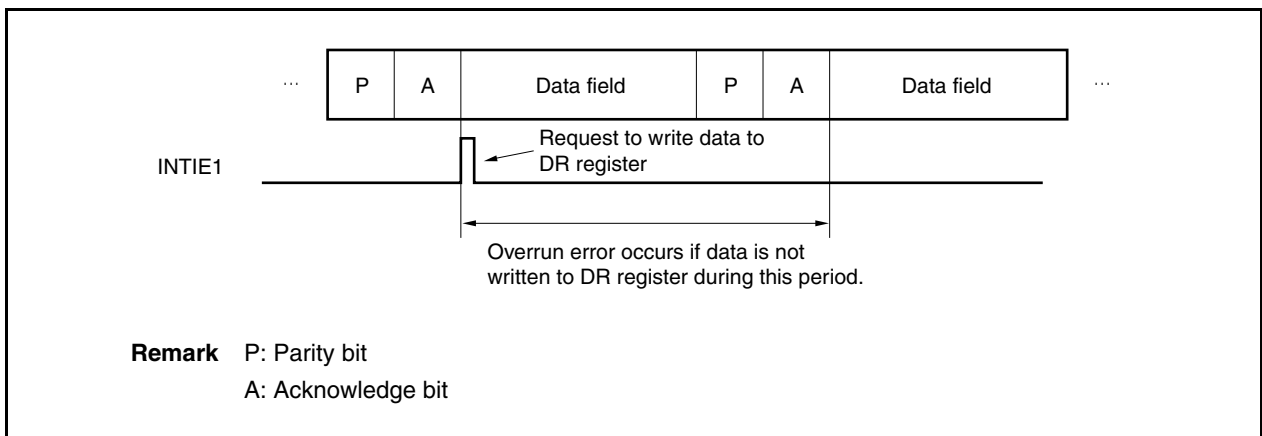
**Figure 20-14. Timing of Overrun Error Occurrence**

**(f) Write error occurrence flag (WERR) ... Bit 2**

&lt;Set/clear conditions&gt;

Set: This flag is set (1) if a write error occurs.

Clear: By software

A write error occurs if the data written to the DR register is not transmitted in the data field during unit transmission. The timing of occurrence of a write error is illustrated below.

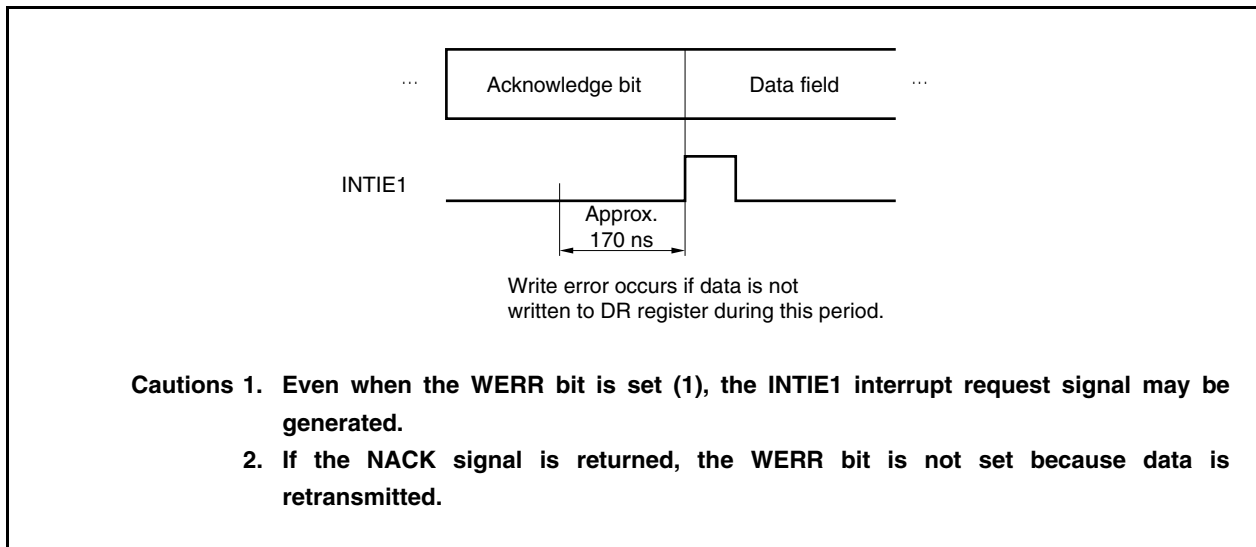
**Figure 20-15. Timing of Write Error Occurrence****(g) Third-party error occurrence flag (DEFLAG)...Bit 0**

&lt;Set/clear conditions&gt;

Set: This flag is set (1) if a timing error or parity error occurs during communication regardless of the unit (during communication between third parties).

Clear: By software

**Caution** If an error occurs before the third-party communication starts even when the slave address field does not match that of the unit (for example, if the NACK signal is received when the received address does not match that of the unit in the slave address field (if the NERR bit is set (1))), the DEFLAG bit is not set (1).

**Remark** Communication between third parties may take place in the following two cases.

- <1> If the received address in the slave address field does not match that of the unit (during individual communication: Matching with UAR register, during broadcast communication: Matching with group or FFFH) and if communication continues after the  $\overline{\text{ACK}}$  signal has been received, the unit monitors that communication.
- <2> If the unit cannot respond to the received control data in the control field during broadcast communication and if communication continues, the unit monitors that communication. For example, this happens when the unit receives control data FH from master during broadcast communication but the slave reception enable flag of the unit is disabled (BCR.ENSLVRX bit = 0) (the NACK signal is returned and communication ends during individual communication).

**(7) IEBus unit address register (UAR)**

The UAR register sets the unit address of an IEBus unit. This register must always be set before starting communication.

Sets the unit address (12 bits) to bits 11 to 0.

This register can be read or written in 16-bit units.

Reset sets this register to 0000H.

	15	14	13	12	11	10	9	8	7	6	5	4	3	2	1	0	Address	After reset	R/W
UAR	0	0	0	0													FFFFF368H	0000H	R/W

**Caution Do not set the UAR register while communication is enabled (BCR.ENIEBUS bit = 1).**

**(8) IEBus slave address register (SAR)**

During a master request, the value of this register is reflected in the value of the transmit data in the slave address field. The SAR register must always be set before starting communication.

The SAR register sets the slave address (12 bits) to bits 11 to 0.

This register can be read or written in 16-bit units.

Reset sets this register to 0000H.

	15	14	13	12	11	10	9	8	7	6	5	4	3	2	1	0	Address	After reset	R/W
SAR	0	0	0	0													FFFFF368H	0000H	R/W

**Caution Be sure to set the SAR register only at the following timing.**

- When the BCR.ENIEBUS bit is 0
- Between when the ENIEBUS bit becomes 1 and the first master request is sent (the BCR.MSTRQ bit is set to 1)
- When the ENIEBUS bit is 1, and the MSTRQ bit is 0 and between either the end of that communication, frame, or error and the next master request (the MSTRQ bit is set to 1)

**(9) IEBus partner address register (PAR)**

The PAR register stores the master address value received in the master address field regardless of whether the unit is operating as the master or a slave.

If a request “4H” to read the lock address (lower 8 bits) is received from the master, read the value of this register by software, and write the data of the lower 8 bits to the DR register.

If a request “5H” to read the lock address (higher 4 bits) is received from the master, read the value of this register by software and write the data of bits 11 to 8 to the higher 4 bits of the DR register.

The PAR register sets the partner address (12 bits) to bits 11 to 0.

This register is read-only, in 16-bit units.

Reset sets this register to 0000H.

	15	14	13	12	11	10	9	8	7	6	5	4	3	2	1	0	Address	After reset	R/W
PAR	0	0	0	0													FFFFFF36AH	0000H	R

**Caution** The PAR register stores an address value if the parity is correct and the unit is not locked when the parity period of the master address field expires. If the PAR register is read at this time, an undefined value is read.

**(10) IEBus receive slave address register (RSA)**

The RSA register stores the slave address value received in the slave address field regardless of whether the unit is operating as the master or a slave.

This register is read-only, in 16-bit units.

Reset sets this register to 0000H.

	15	14	13	12	11	10	9	8	7	6	5	4	3	2	1	0	Address	After reset	R/W
RSA	0	0	0	0													FFFFFF36CH	0000H	R

**Caution** The RSA register stores an address value if the parity is correct and the unit is not locked when the parity period of the slave address field expires. If the RSA register is read at this time, an undefined value is read.

**(11) IEBus control data register (CDR)**

The CDR register can be read or written in 8-bit units.

Reset sets this register to 00H.

**Remark** The CDR register consists of a write register and a read register and data written to the CDR register cannot be read as is. The data read from this register is the data received by IEBus communication.

**(a) When master unit**

The data of the lower 4 bits is reflected in the data transmitted in the control field. During a master request, the CDR register must be set in advance before starting communication.

**(b) When slave unit**

The data received in the control field is written to the lower 4 bits.

When the status transmission flag (ISR.STATUSF bit) is set (1), an interrupt request signal (INTIE2) is issued, and each processing should be performed by software, according to the value of the lower 4 bits of the CDR register.

After reset: 00H R/W Address: FFFFF36EH

	7	6	5	4	3	2	1	0
CDR	0	0	0	0	MOD	SELCL2	SELCL1	SELCL0

MOD	SELCL2	SELCL1	SELCL0	Function
0	0	0	0	Read slave status
0	0	0	1	Undefined
0	0	1	0	Undefined
0	0	1	1	Read data and lock
0	1	0	0	Read lock address (lower 8 bits)
0	1	0	1	Read lock address (lower 4 bits)
0	1	1	0	Read slave status and unlock
0	1	1	1	Read data
1	0	0	0	Undefined
1	0	0	1	Undefined
1	0	1	0	Write command and lock
1	0	1	1	Write data and lock
1	1	0	0	Undefined
1	1	0	1	Undefined
1	1	1	0	Write command
1	1	1	1	Write data

- Cautions**
1. Because the slave unit must judge whether the received data is a “command” or “data”, read the value of the CDR register after completing communication.
  2. If the master unit sets an undefined value, the slave unit returns the NACK signal and communication is aborted. During broadcast communication, the master unit ignores the acknowledge bit and continues communication. Therefore, do not set an undefined value.
  3. Be sure to set bits 4 to 7 to “0”.

**(c) Slave status return operation**

When IEBus receives a request to transfer from master to slave status or a lock address request (control data: 0H, 6H), whether the  $\overline{\text{ACK}}$ /NACK signal in the control field is returned or not depends on the status of the IEBus unit.

- (1) If 0H or 6H control data was received in the unlocked state →  $\overline{\text{ACK}}$  signal returned
- (2) If 4H or 5H control data was received in the unlocked state → NACK signal returned
- (3) If 0H, 4H, 5H or 6H control data was received in the locked state from the unit that sent the lock request →  $\overline{\text{ACK}}$  signal returned
- (4) If 0H, 4H, or 5H control data was received in the locked state from other than the unit that sent the lock request →  $\overline{\text{ACK}}$  signal returned
- (5) If 6H control data was received in the locked state from other than the unit that sent the lock request → NACK signal returned

In all of the above cases, the acknowledgment of a slave status or lock request will cause the STATUSF bit to be set (1) and the status interrupt signal (INTIE2, INTSTA) to be generated. The generation timing is at the end of the control field parity bit (at the start of the acknowledge bit). However, if NACK is returned, a NACK receive error is generated after the acknowledge bit, and communication is terminated.

**Figure 20-16. Interrupt Request Signal Generation Timing (for (1), (3), and (4))**

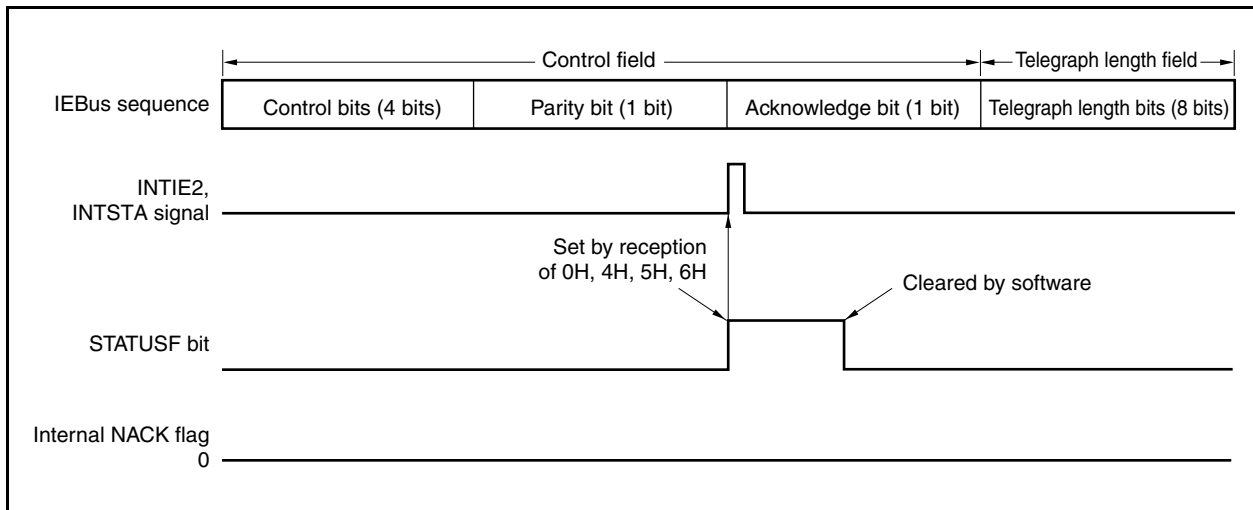
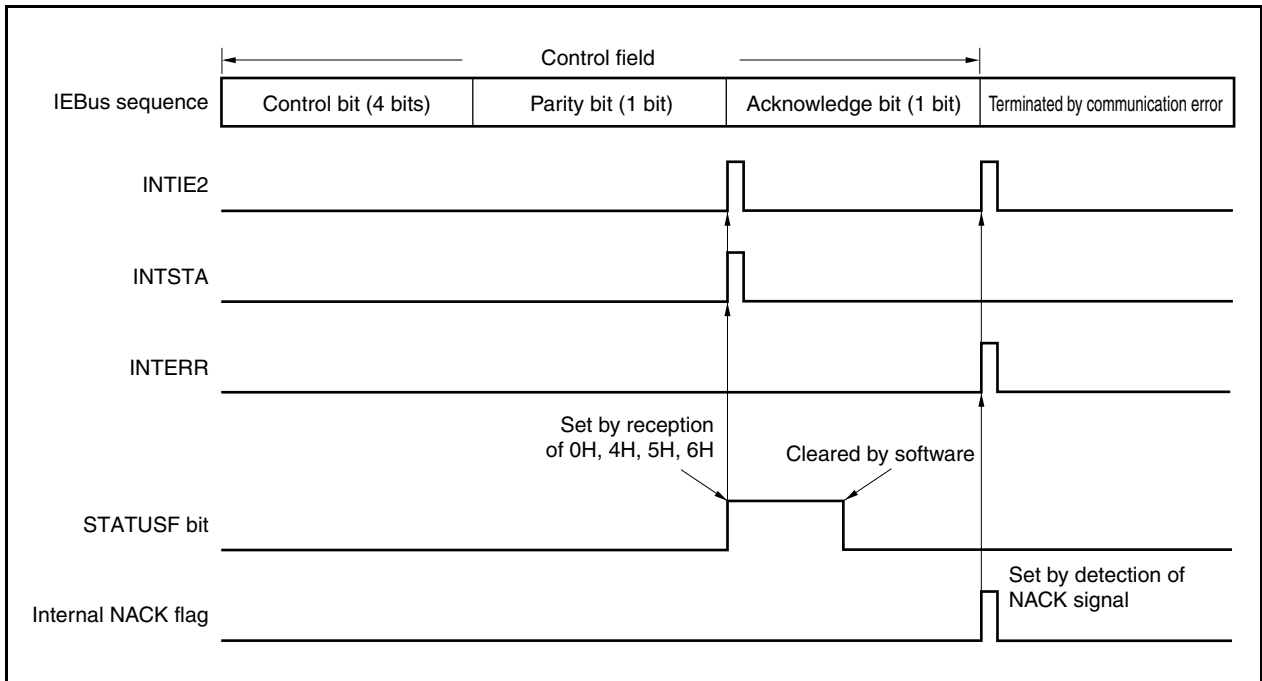

Figure 20-17. Interrupt Request Signal Generation Timing (for (2) and (5))



Because in (4) and (5) the communication was from other than the unit that sent the lock request while IEBus was in the locked state, the start or communication end interrupt request signals (INTIE2, INTSTA) are not generated, even if the IEBus unit is the communication target. The STATUSF bit is set (1) and the status interrupt request signals (INTIE2, INTSTA) are generated, however, if a slave status or lock address request is acknowledged. Note that even if the same control data is received while IEBus is in the locked state, the interrupt generation timing for INTIE2 and INTSTA differs depending on whether the master unit (3) or another unit (4) is requesting the locked state.

Figure 20-18. Timing of INTIE2 and INTSTA Interrupt Request Signal Generation in Locked State (for (4) and (5))

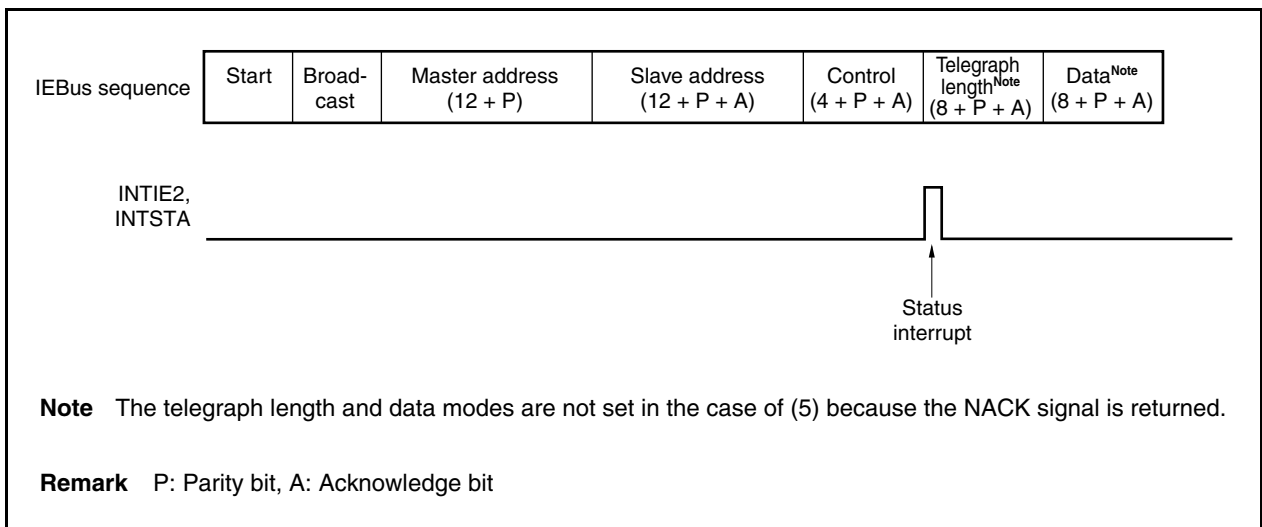
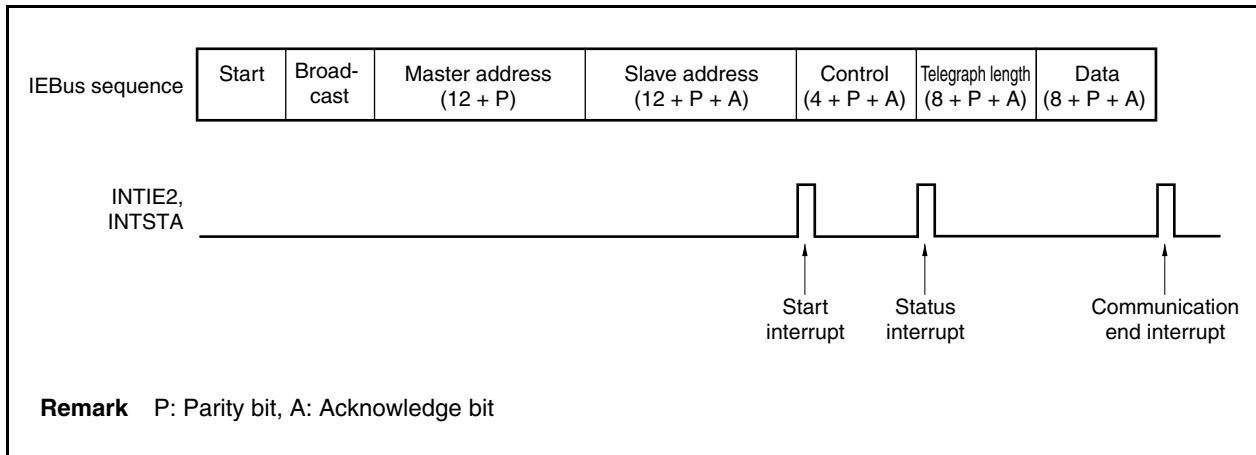

Figure 20-19. Timing of INTIE2 and INTSTA Interrupt Request Signal Generation in Locked State (for (3))





**(12) IEBus telegraph length register (DLR)**

The DLR register can be read or written in 8-bit units.

Reset sets this register to 01H.

**(a) When transmission unit ... Master transmission, slave transmission**

The data of this register is reflected in the data transmitted in the telegraph length field and indicates the number of bytes of the transmit data. The DLR register must be set in advance before transmission.

**(b) When reception unit ... Master reception, slave reception**

The receive data in the telegraph length field transmitted from the transmission unit is written to this register.

**Remark** The DLR register consists of a write register and a read register. Consequently, data written to this register cannot be read as is. The data that can be read is the data received during IEBus communication.

After reset: 01H R/W Address: FFFF36FH

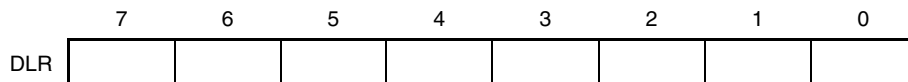

Bit								Setting value	Remaining number of communication data bytes
7	6	5	4	3	2	1	0		
0	0	0	0	0	0	0	1	01H	1 byte
0	0	0	0	0	0	1	0	02H	2 bytes
:	:	:	:	:	:	:	:	:	:
0	0	1	0	0	0	0	0	20H	32 bytes
:	:	:	:	:	:	:	:	:	:
1	1	1	1	1	1	1	1	FFH	255 bytes
0	0	0	0	0	0	0	0	00H	256 bytes

- Cautions**
1. When the master issues a request (0H, 4H, 5H, or 6H) for transmission of a slave status or a lock address (higher 4 bits and lower 8 bits), 01H is transmitted as the telegraph length regardless of the contents of the DLR register. It is therefore not necessary to set the DLR register by software.
  2. When the IEBus controller serves as a receiver unit, the DLR register stores a telegraph length if the value of the parity bit of the telegraph length field is correct. If the DLR register is read at this time, an undefined value is read.

**(13) IEBus data register (DR)**

The DR register sets the communication data (8 bits) to bits 7 to 0.

This register can be read or written in 8-bit units.

Reset sets this register to 00H.

**Remark** The DR register consists of a write register and a read register. Consequently, data written to this register cannot be read as is. The data that can be read is the data received during IEBus communication.

**(a) When transmission unit**

The data (1 byte) written to the DR register is stored in the transmit shift register of the IEBus interface block. It is then output from the most significant bit, and an interrupt request signal (INTIE1) is generated each time 1 byte has been transmitted. If the NACK signal is received after 1-byte data has been transferred during individual transfer, data is not transferred from the DR register to the transmit shift register, and the same data is retransmitted. At this time, INTIE1 signal is not generated.

INTIE1 signal is generated when the transmit shift register stores the DR register value. However, when the last byte and 32nd byte (the last byte of 1 communication frame) is stored in the transmit shift register, the INTIE1 signal is not generated.

**(b) When reception unit**

One byte of the data received by the receive shift register of the IEBus interface block is stored in this register.

Each time 1 byte has been correctly received, an interrupt request signal (INTIE1) is generated.

When transmit/receive data is transferred to and from the DR register, using DMA can reduce the CPU processing load.

After reset: 00H R/W Address: FFFF370H

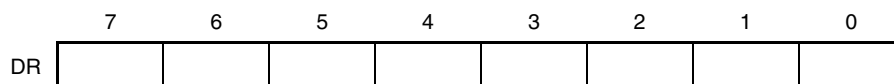

- Cautions**
1. If the next data is not in time while the transmission unit is set, an underrun occurs, and a communication error interrupt request signal (INTIE2, INTERR) occurs, stopping transmission.
  2. If data is not read in time before the next data is read when the IEBus controller functions as a receiver unit during individual communication reception, the NACK signal is returned by the acknowledge bit of the data field, requesting the master to retransmit the data. If the DR register is not read after the data has reached the maximum number of transmit bytes, however, the frame end interrupt request signal (INTIE2, INTSTA) and NACK reception error interrupt request signal (INTIE2, INTERR) are generated at the same time.
  3. If data is not read in time before the next data is received when the IEBus controller functions as a receiver unit during broadcast communication reception, an overrun error occurs and the communication error interrupt request signal (INTIE2, INTERR) is generated.
  4. When the IEBus controller serves as a receiver unit, the DR register stores receive data if the value of the parity bit of the data field is correct. If the DR register is read at this time, an undefined value is read.

**(14) IEBus field status register (FSR)**

The FSR register stores the status of the field status of the IEBus controller if an interrupt request signal (INTIE1, INTIE2, INTSTA, or INTERR) is generated.

This register is read-only, in 8-bit units.

Reset sets this register to 00H.

- Cautions**
1. If an interrupt request signal is generated during communication between third parties, the FSR register is cleared to 00H. However, because only an interrupt request signal that is generated if an error occurs is generated during communication between third parties, the error can be identified as that during communication between third parties, by reading third-party error flag (ESR.DEFLAG bit).
  2. The FSR register updates the status information when an interrupt request signal is generated. If the FSR register is read at this time, however, an undefined value is read.
  3. If another interrupt request signal is generated before the FSR register is read, the status information when the preceding interrupt occurred is updated by the status information when the new interrupt occurs.
  4. Use the FSR register only for problem analysis; do not use it with the actual software.

After reset: 00H    R    Address: FFFFF371H

FSR	7	6	5	4	3	2	1	0
	0	0	0	0	0	0	FSTATE1	FSTATE0

**Remark** For the explanation of the FSTATE1 and FSTATE0 bits, see **Table 20-15 Field Status**.

**Table 20-15. Field Status**

Field Status	Explanation		
	Master/Slave	Field	Transmission/Reception
Slave transmission status FSR = 00H	Slave operation	Start field	Reception
		Master address field	
		Slave address field	
		Control data field	
		Telegraph length field	
Slave transmission status FSR = 01H	Slave operation	Telegraph length field	Transmission
		Data field	
Master reception status FSR = 02H	Master operation	Telegraph length field	Reception
		Data field	
Master transmission status FSR = 03H	Master operation	Start field	Transmission
		Master address field	
		Slave address field	
		Control data field	
		Telegraph length field	
		Data field	

**(15) IEBus success count register (SCR)**

The SCR register indicates the number of remaining communication bytes.

The count value of the counter in which the value set by the DLR register is decremented by the  $\overline{\text{ACK}}$  signal in the data field is read from this register. When the count value has reached "00H", the communication end flag (ISR.ENDTRNS bit) is set (1).

This register is read-only, in 8-bit units.

Reset sets this register to 01H.

After reset: 01H R Address: FFFFF372H

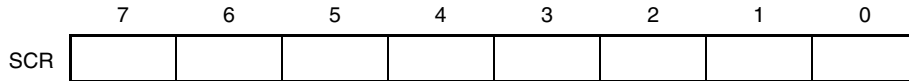

Bit								Setting value	Remaining number of communication data bytes
7	6	5	4	3	2	1	0		
0	0	0	0	0	0	0	1	01H	1 byte
0	0	0	0	0	0	1	0	02H	2 bytes
:	:	:	:	:	:	:	:	:	:
0	0	1	0	0	0	0	0	20H	32 bytes
:	:	:	:	:	:	:	:	:	:
1	1	1	1	1	1	1	1	FFH	255 bytes
0	0	0	0	0	0	0	0	00H	0 bytes (end of communication) or 256 bytes <sup>Note</sup>

**Note** The actual counter consists of 9 bits. When "00H" is read, it cannot be judged whether the remaining number of communication data bytes is 0 (end of communication) or 256. Therefore, either the communication end flag (ENDTRNS bit) is used, or if "00H" is read when the first interrupt occurs at the beginning of communication, the remaining number of communication data bytes is judged to be 256.

**Caution** The SCR register is updated when the parity period of the telegraph field expires and when the  $\overline{\text{ACK}}$  signal of the data field is received. If the SCR register is read at this time, however, an undefined value is read.

**(16) IEBus communication count register (CCR)**

The CCR register indicates the number of bytes remaining from the communication byte number specified by the communication mode.

This register indicates the number of transfer bytes.

The maximum number of transmitted bytes per frame defined in each mode (mode 1: 32 bytes, mode 2: 128 bytes) is preset to this register. The count value of the counter that is decremented during the acknowledge bit period of the data field regardless of the  $\overline{\text{ACK}}/\text{NACK}$  signal is read from this register. Whereas the SCR register is decremented during normal communication ( $\overline{\text{ACK}}$  signal), the CCR register is decremented when 1 byte has been communicated, regardless of whether the signal is  $\overline{\text{ACK}}$  or NACK. When the count value has reached "00H", the frame end flag (ISR.ENDFRAM bit) is set (1).

The preset value of the maximum number of transmitted bytes per frame is 20H (32 bytes) in mode 1 and 80H (128 bytes) in mode 2.

This register is read-only, in 8-bit units.

Reset sets this register to 20H.

After reset: 20H R Address: FFFFF373H

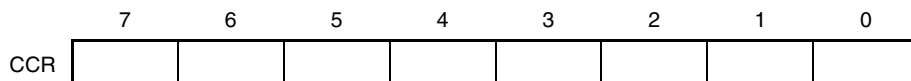

**Caution** The maximum number of transmit bytes is preset to the CCR register when the start bit is transmitted or received, and the register is decremented when the parity period of the data field expires. If the CCR register is read at this time, however, an undefined value is read.

**(17) IEBus clock select register (OCKS2)**

The OCKS2 register selects the clock of IEBus. The IEBus clock frequencies ( $f_{IE}$ ) that can be used are shown below. No other main clock frequencies can be used.

This register can be read or written in 8-bit units.

Reset sets this register to 00H.

- 6.0 MHz/6.291456 MHz (6.29 MHz)
- 12.0 MHz/12.582912 MHz (12.58 MHz)
- 18.0 MHz/18.874368 MHz (18.87 MHz)
- 24.0 MHz/25.165824 MHz (25.16 MHz)
- 30.0 MHz/31.457280 MHz (31.45 MHz)

After reset: 00H R/W Address: FFFFF348H

	7	6	5	4	3	2	1	0
OCKS2	0	0	0	OCKSEN2	OCKSTH2	0	OCKS21	OCKS20

OCKSEN2	IEBus clock operation specification
0	IEBus clock operation stops
1	IEBus clock operation enabled

OCKSTH2	OCKS21	OCKS20	IEBus clock selection
0	0	0	$f_{IE}/2$ (when $f_{IE} = 12.0$ MHz or $f_{IE} = 12.58$ MHz)
0	0	1	$f_{IE}/3$ (when $f_{IE} = 18.0$ MHz or $f_{IE} = 18.87$ MHz)
1	1	0	$f_{IE}/4$ (when $f_{IE} = 24.0$ MHz or $f_{IE} = 25.16$ MHz)
0	1	1	$f_{IE}/5$ (when $f_{IE} = 30.0$ MHz or $f_{IE} = 31.45$ MHz)
1	0	0	$f_{IE}$ (when $f_{IE} = 6.0$ MHz or $f_{IE} = 6.29$ MHz)
Other than above			Setting prohibited

**Caution** Be sure to set bits 2 and 5 to 7 to “0”.

**Remark**  $f_{IE}$ : IEBus clock frequency  
 In clock mode 1,  $f_{IE} = f_{XX}$   
 In clock mode 2,  $f_{IE} = f_{XMPLL}$  (29.28 to 32 MHz)  
 In clock mode 3,  $f_{IE} = f_{XMPLL}$  (29.28 to 32 MHz)  
 In clock mode 4,  $f_{IE} = f_{XMPLL}/2$  (20.88 to 24 MHz)

$f_{XX}$ : Main clock frequency  
 $f_{XMPLL}$ : PLL output clock frequency for peripheral clocks

## 20.4 Interrupt Operations of IEBus Controller

### 20.4.1 Interrupt control block

Interrupt request signal

<1>	Communication error	IEERR
	(i) Timing error:	TERR
	(ii) Parity error:	PERR
	(iii) NACK receive error:	NERR
	(iv) Underrun error:	UERR
	(v) Overrun error:	OERR
	(vi) Write error:	WERR
<2>	Start interrupt	STARTF
<3>	Status communication	STATUSF
<4>	End of communication	ENDTRNS
<5>	End of frame	ENDFRAM
<6>	Transmit data write request	$\overline{\text{STATTX}}$
<7>	Receive data read request	STATRX

A communication error <1> occurs if any of the above error sources (i) to (vi) is generated.

These error sources are assigned to the error status register (ESR) (see **Table 20-18 Communication Error Source Processing List**).

The above interrupt signals <1> to <5> are assigned to the ISR register (see **Table 20-17 Interrupt Source List**).

The configuration of the interrupt control block is illustrated below.

Figure 20-20. Configuration of Interrupt Control Block

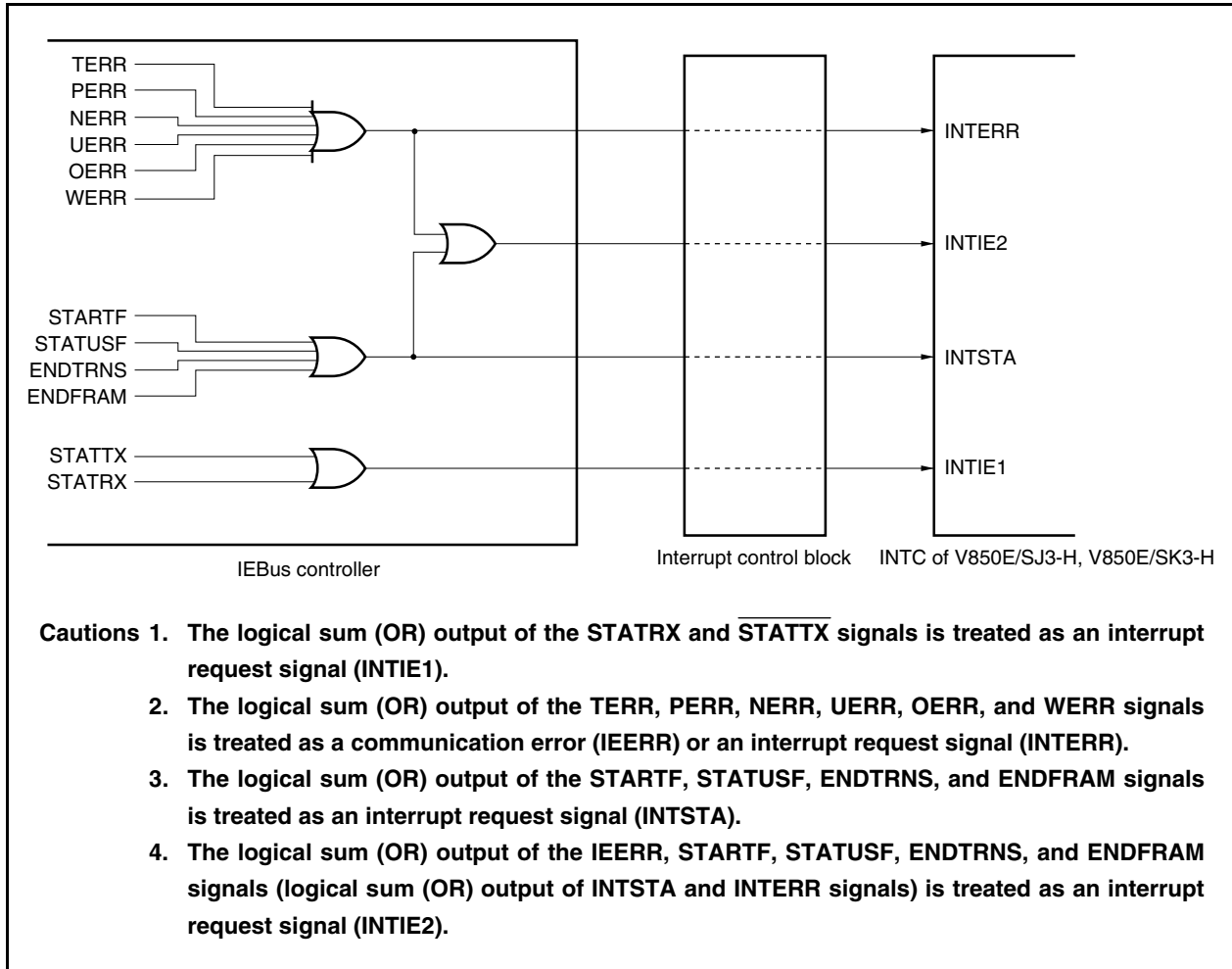

Table 20-16. Interrupt Request Signal Generation Source List

Interrupt Source	Symbol	Interrupt Request Signal			
		INTIE1	INTIE2	INTERR	INTSTA
Communication error interrupt	IEERR		√	√	
Timing error	TERR				
Parity error	PERR				
NACK reception error	NERR				
Underrun error	UERR				
Overrun error	OERR				
Write error	WERR				
Start interrupt	STARTF		√		√
Status transmission	STATUSF		√		√
End of Communication	ENDTRNS		√		√
End of frame	ENDFRAM		√		√
Transmit data write request	$\overline{\text{STATTX}}$	√			
Receive data write request	STATRX	√			



**20.4.2 Example of identifying interrupt**

The IEBus controller processes interrupts in the following two ways.

- Using three interrupt request signals: INTIE1, INTERR, and INTSTA
- Using two interrupt request signals: INTIE1 and INTIE2

**Caution** Mask the interrupt sources that are not used so that the interrupts do not occur.

How an interrupt is identified in each of the above cases is explained below.

**(1) When INTIE1, INTERR, and INTSTA signals are used**

**Figure 20-21. Example of Identifying INTIE1 Signal Interrupt  
(When INTIE1, INTERR, and INTSTA Signals Are Used)**

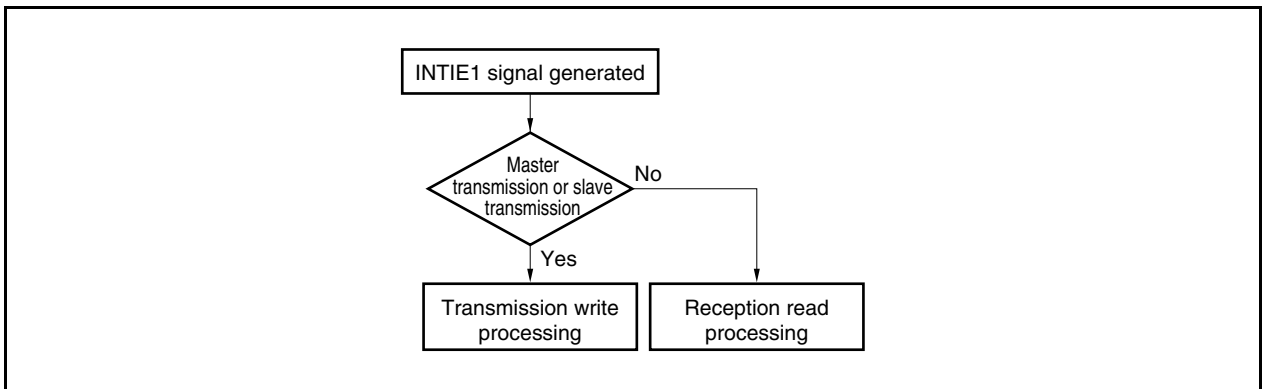

**Figure 20-22. Example of Identifying INTERR Signal Interrupt  
(When INTIE1, INTERR, and INTSTA Signals Are Used)**

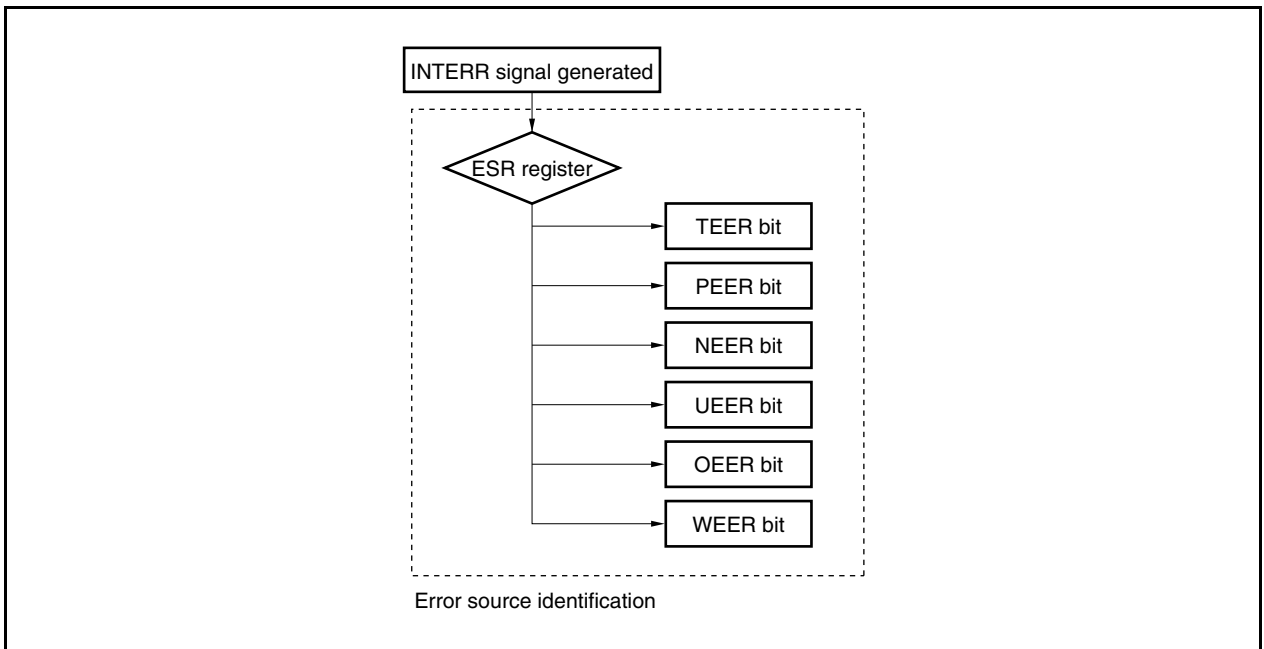

**Figure 20-23. Example of Identifying INTSTA Signal Interrupt (When INTIE1, INTERR, and INTSTA Signals Are Used)**

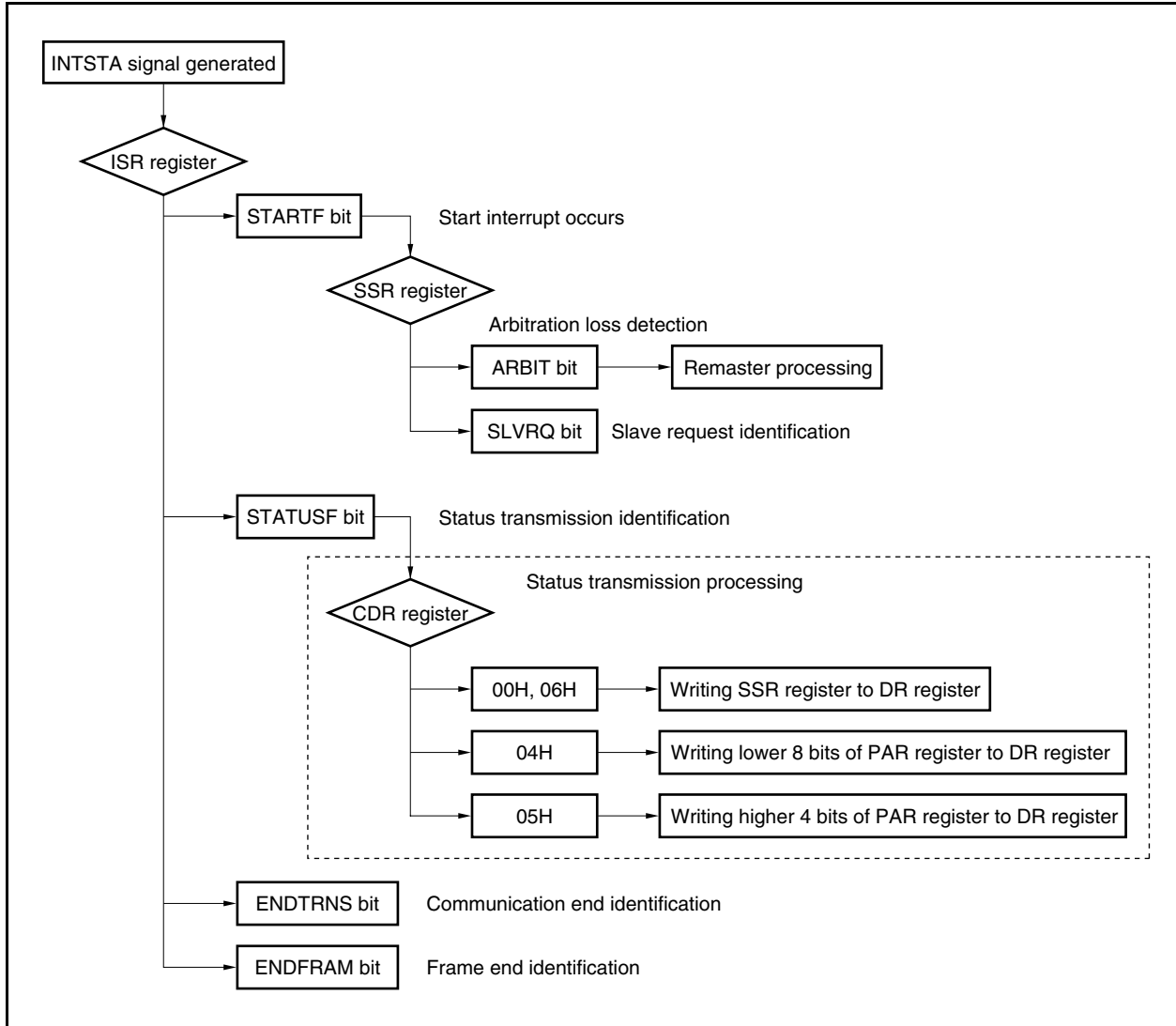

**(2) When INTIE1 and INTIE2 signals are used**

**Figure 20-24. Example of Identifying INTIE1 Signal Interrupt (When INTIE1 and INTIE2 Signals Are Used)**

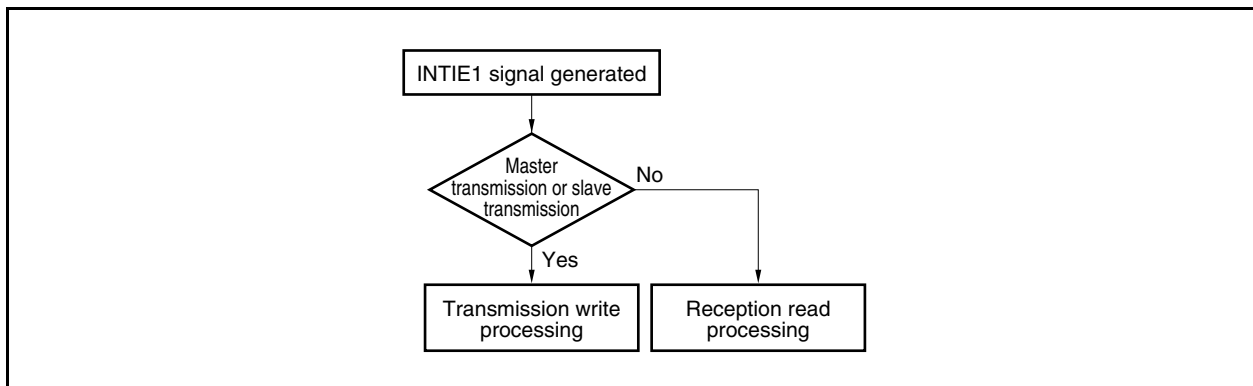
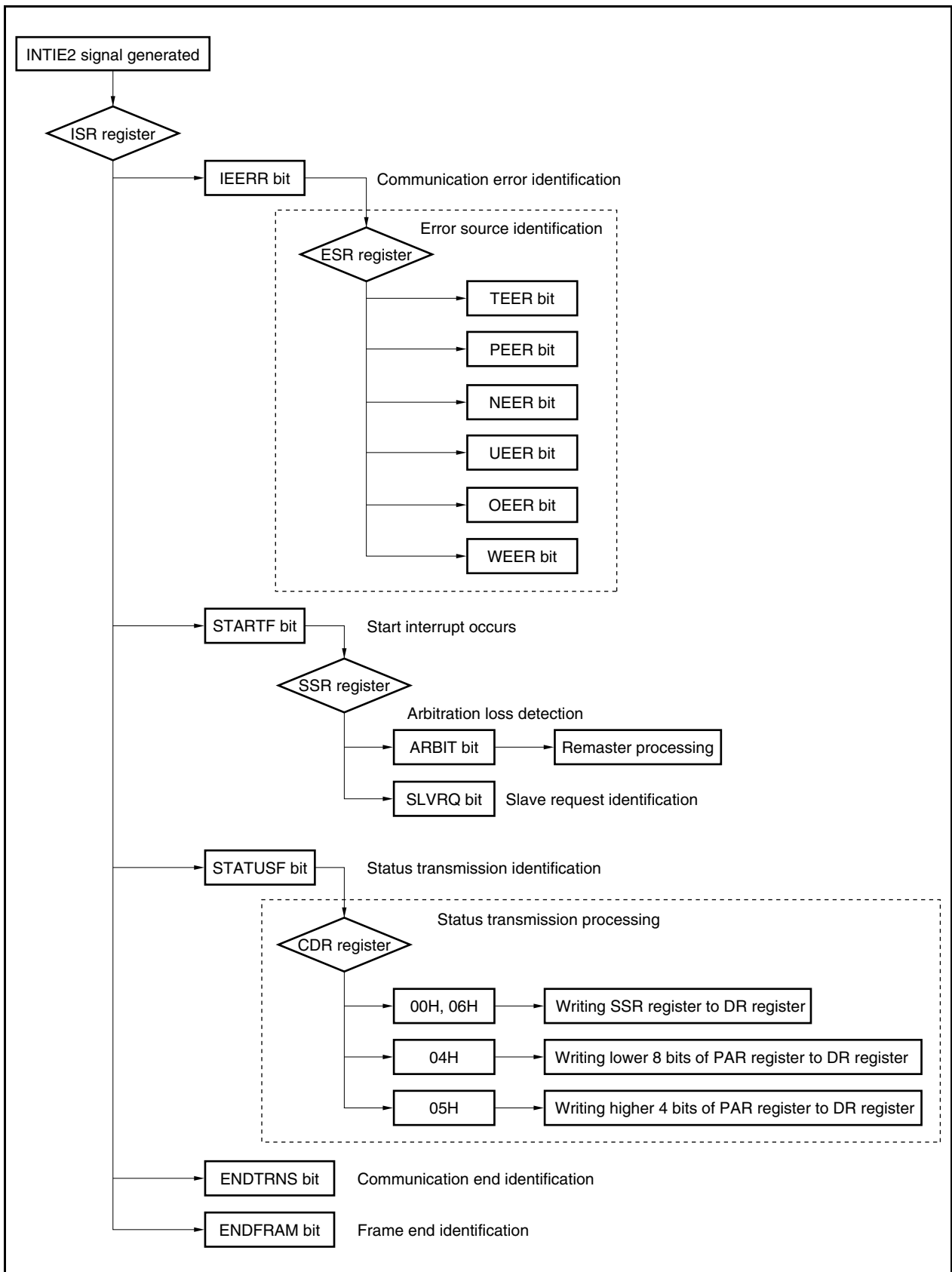

Figure 20-25. Example of Identifying INTIE2 Signal Interrupt (When INTIE1 and INTIE2 Signals Are Used)



### 20.4.3 Interrupt source list

The interrupt request signals of the internal IEBus controllers in the V850E/SJ3-H and V850E/SK3-H can be classified into vector interrupts and DMA transfer interrupts. These interrupt request signals can be specified via software manipulation.

The interrupt sources are listed below.

**Table 20-17. Interrupt Source List**

Interrupt Source		Condition of Generation		Software Processing After Generation of Interrupt Request Signal	Remark
		Unit	Field		
Communication error	Timing error	Master/slave	All fields	Undo communication processing	Communication error is logical sum (OR) output of timing error, parity error, NACK reception error, underrun error, overrun error, and write error.
	Parity error	Reception	Other than data (individual)		
			All fields (broadcast)		
	NACK reception	Reception (Transmission)	Other than data (individual)		
	Underrun error	Transmission	Data		
	Overrun error	Reception	Data (broadcast)		
	Write error	Transmission	Data		
Start interrupt	Master	Slave/address	Slave request judgment Arbitration judgment (If lost, remaster processing) Communication preparation processing	Interrupt always occurs if lost in arbitration during master request	
			Slave	Slave request judgment Communication preparation processing	Generated only during slave request
Status transmission	Slave	Control	Refer to transmission processing example such as slave status.	Interrupt occurs regardless of slave transmission enable flag Interrupt occurs if NACK is returned in the control field.	
End of communication	Transmission	Data	DMA transfer end processing	Set if SCR register is cleared to 00H	
	Reception	Data	DMA transfer end processing Receive data processing		
End of frame	Transmission	Data	Retransmission preparation processing	Set if CCR register is cleared to 00H	
	Reception	Data	Re-reception preparation processing		
Transmit data write	Transmission	Data	Reading of transmit data <sup>Note</sup>	Set after transfer transmission data to internal shift register This does not occur when the last data is transferred.	
Receive data read	Reception	Data	Reading of received data <sup>Note</sup>	Set after normal data reception	

**Note** If DMA transfer or software manipulation is not executed.

20.4.4 Communication error source processing list

The following table shows the occurrence conditions of the communication errors (timing error, NACK reception error, overrun error, underrun error, parity error, and write error), error processing by the IEBus controller, and examples of processing by software.

Table 20-18. Communication Error Source Processing List (1/2)

		Timing Error			
Occurrence condition	Unit status	Reception		Transmission	
	Occurrence condition	If bit specification timing is not correct			
	Location of occurrence	Other than data field	Data field	Other than data field	Data field
Broadcast communication	Hardware processing	<ul style="list-style-type: none"> <li>Reception stops.</li> <li>INTIE2 signal occurs.</li> <li>To start bit waiting status</li> </ul> <p><b>Remark</b> Communication between other units does not end.</p>		<ul style="list-style-type: none"> <li>Transmission stops.</li> <li>INTIE2 signal occurs.</li> <li>To start bit waiting status</li> </ul>	
	Software processing	<ul style="list-style-type: none"> <li>Error processing (such as retransmission request)</li> </ul>		<ul style="list-style-type: none"> <li>Error processing (such as retransmission request)</li> </ul>	
Individual communication	Hardware processing	<ul style="list-style-type: none"> <li>Reception stops.</li> <li>INTIE2 signal occurs.</li> <li>NACK signal is returned.</li> <li>To start bit waiting status</li> </ul>		<ul style="list-style-type: none"> <li>Transmission stops.</li> <li>INTIE2 signal occurs.</li> <li>To start bit waiting status</li> </ul>	
	Software processing	<ul style="list-style-type: none"> <li>Error processing (such as retransmission request)</li> </ul>		<ul style="list-style-type: none"> <li>Error processing (such as retransmission request)</li> </ul>	

		NACK Reception Error				
Occurrence condition	Unit status	Reception		Transmission		
	Occurrence condition	Unit NACK signal transmission		Unit NACK signal transmission		
	Location of occurrence	Other than data field	Data field	Other than data field	Data field	NACK signal reception of data of 32nd byte
Broadcast communication	Hardware processing	–	–	–	–	–
	Software processing	–	–	–	–	–
Individual communication	Hardware processing	<ul style="list-style-type: none"> <li>Reception stops.</li> <li>INTIE2 signal occurs.</li> <li>To start bit waiting status</li> </ul>	<ul style="list-style-type: none"> <li>INTIE2 signal does not occur.</li> <li>Data retransmitted by other unit is received.</li> </ul>	<ul style="list-style-type: none"> <li>Reception stops.</li> <li>INTIE2 signal occurs.</li> <li>To start bit waiting status</li> </ul>	<ul style="list-style-type: none"> <li>INTIE2 signal does not occur.</li> <li>Retransmission processing</li> </ul>	<ul style="list-style-type: none"> <li>INTIE2 signal occurs.</li> <li>To start bit waiting status</li> </ul>
	Software processing	<ul style="list-style-type: none"> <li>Error processing (such as retransmission request)</li> </ul>	–	<ul style="list-style-type: none"> <li>Error processing (such as retransmission request)</li> </ul>	–	<ul style="list-style-type: none"> <li>Error processing (such as retransmission request)</li> </ul>

**Table 20-18. Communication Error Source Processing List (2/2)**

		Overrun Error		Underrun Error/Write Error	
Occurrence condition	Unit status	Reception		Transmission	
	Occurrence condition	DR register cannot be read in time before the next data is received.		DR register cannot be written in time before the next data is transmitted.	
	Location of occurrence	Other than data field	Data field	Other than data field	Data field
Broadcast communication	Hardware processing	–	<ul style="list-style-type: none"> <li>• Reception stops.</li> <li>• INTIE2 signal occurs.</li> <li>• To start bit waiting status</li> </ul> <p><b>Remarks</b></p> <ol style="list-style-type: none"> <li>1. Communication between other units does not end.</li> <li>2. Data cannot be received until the overrun status is cleared.</li> </ol>	–	<ul style="list-style-type: none"> <li>• Transmission stops.</li> <li>• INTIE2 signal occurs.</li> <li>• To start bit waiting status</li> </ul>
	Software processing	–	<ul style="list-style-type: none"> <li>• DR register is read and overrun status is cleared.</li> <li>• Error processing (such as retransmission request)</li> </ul>	–	<ul style="list-style-type: none"> <li>• Error processing (such as retransmission request)</li> </ul>
Individual communication	Hardware processing	–	<ul style="list-style-type: none"> <li>• INTIE2 signal does not occur.</li> <li>• NACK signal is returned.</li> <li>• Data is retransmitted from other unit.</li> </ul> <p><b>Remark</b> Data cannot be received until overrun status is cleared.</p>	–	<ul style="list-style-type: none"> <li>• Transmission stops.</li> <li>• INTIE2 signal occurs.</li> <li>• To start bit waiting status</li> </ul>
	Software processing	–	<ul style="list-style-type: none"> <li>• DR register is read and overrun status is cleared.</li> <li>• Error processing (such as retransmission request)</li> </ul>	–	<ul style="list-style-type: none"> <li>• Error processing (such as retransmission request)</li> </ul>

		Parity Error			
Occurrence condition	Unit status	Reception		Transmission	
	Occurrence condition	Received data and received parity do not match.		–	
	Location of occurrence	Other than data field	Data field	Other than data field	Data field
Broadcast communication	Hardware processing	<ul style="list-style-type: none"> <li>• Reception stops.</li> <li>• INTIE2 signal occurs.</li> <li>• To start bit waiting status</li> </ul> <p><b>Remark</b> Communication between other units does not end.</p>		–	–
	Software processing	<ul style="list-style-type: none"> <li>• Error processing (such as retransmission request)</li> </ul>		–	–
Individual communication	Hardware processing	<ul style="list-style-type: none"> <li>• Reception stops.</li> <li>• INTIE2 signal occurs.</li> <li>• To start bit waiting status</li> </ul>	<ul style="list-style-type: none"> <li>• Reception does not stop.</li> <li>• INTIE2 signal does not occur.</li> <li>• NACK signal is returned.</li> <li>• Data retransmitted by other unit is received.</li> </ul>	–	–
	Software processing	<ul style="list-style-type: none"> <li>• Error processing (such as retransmission request)</li> </ul>	–	–	–

## 20.5 Interrupt Request Signal Generation Timing and Main CPU Processing

### 20.5.1 Master transmission

Initial preparation processing:

Sets a unit address, slave address, control data, telegraph length, and the first byte of the transmit data.

Communication start processing:

Set the BCR register (enable communication, master request, and slave reception).

**Figure 20-26. Master Transmission**

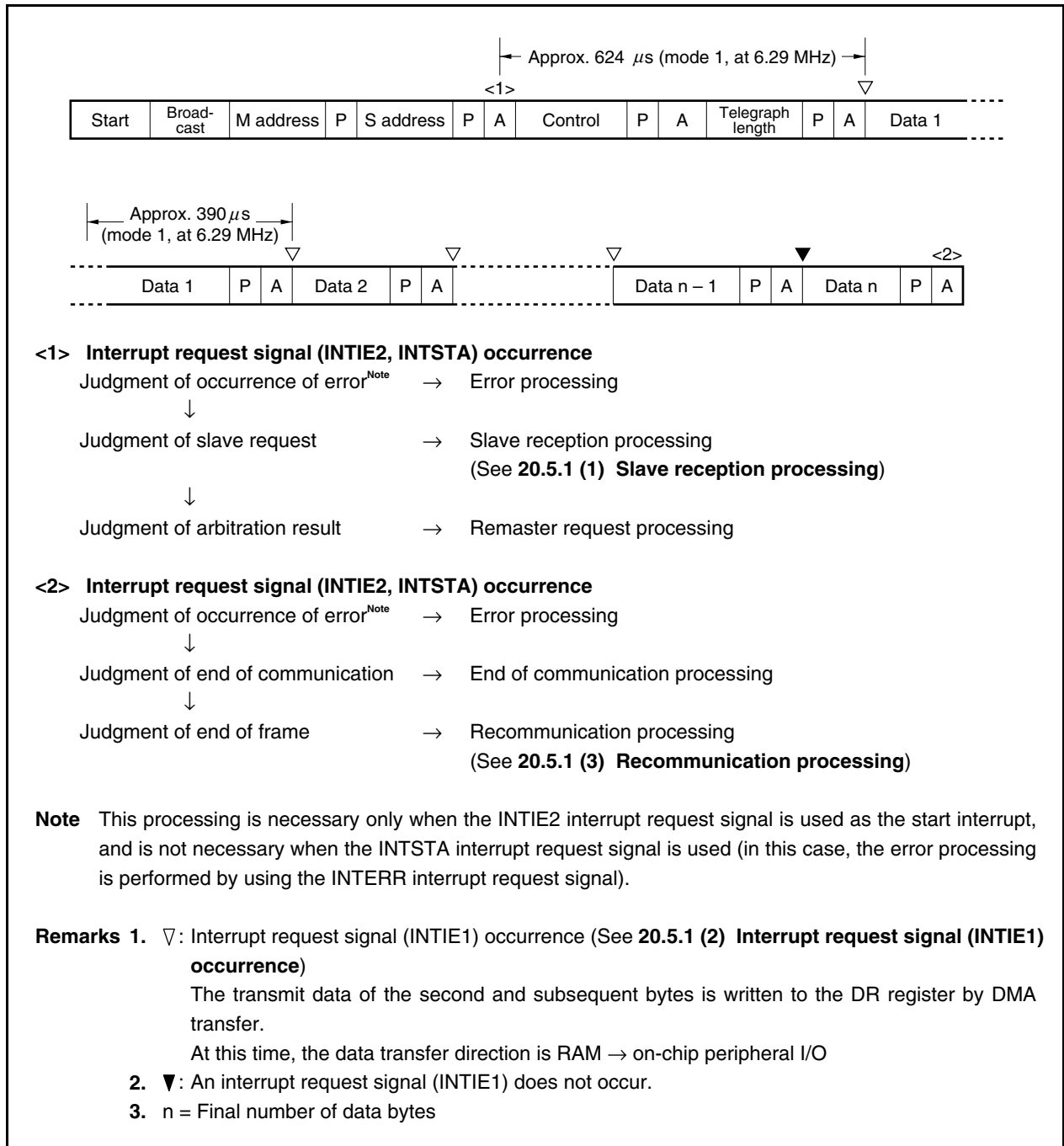

**(1) Slave reception processing**

If a slave reception request is confirmed during vector interrupt servicing, the data transfer direction of the macro service must change from RAM → on-chip peripheral I/O to on-chip peripheral I/O → RAM until the first data is received. The maximum pending period of this data transfer direction changing processing is about 1,040  $\mu$ s in communication mode 1 (at 6.29 MHz).

**(2) Interrupt request signal (INTIE1) occurrence**

If the NACK signal is received from the slave in the data field, an interrupt request signal (INTIE1) is not issued to the interrupt controller (INTC), and the same data is retransmitted by hardware.

If the transmit data is not written in time during the period of writing the next data, a communication error interrupt request signal (INTERR) occurs due to occurrence of underrun, and communication ends midway.

**(3) Recommunication processing**

In the vector interrupt servicing in <2>, it is judged whether the data has been correctly transmitted within one frame. If the data has not been correctly transmitted (if the number of data to be transmitted in one frame could not be transmitted), the data must be retransmitted in the next frame, or the remainder of the data must be transmitted.



**20.5.2 Master reception**

Before performing master reception, it is necessary to notify the unit that will be the slave of slave transmission. Therefore, more than two communication frames are necessary for master reception. The slave unit prepares the transmit data, sets (1) the slave transmission enable flag (BCR.ENSLVTX bit), and waits.

Initial preparation processing:

Set a unit address, slave address, and control data.

Communication start processing:

Set the BCR register (enable communication and master request).

**Figure 20-27. Master Reception**

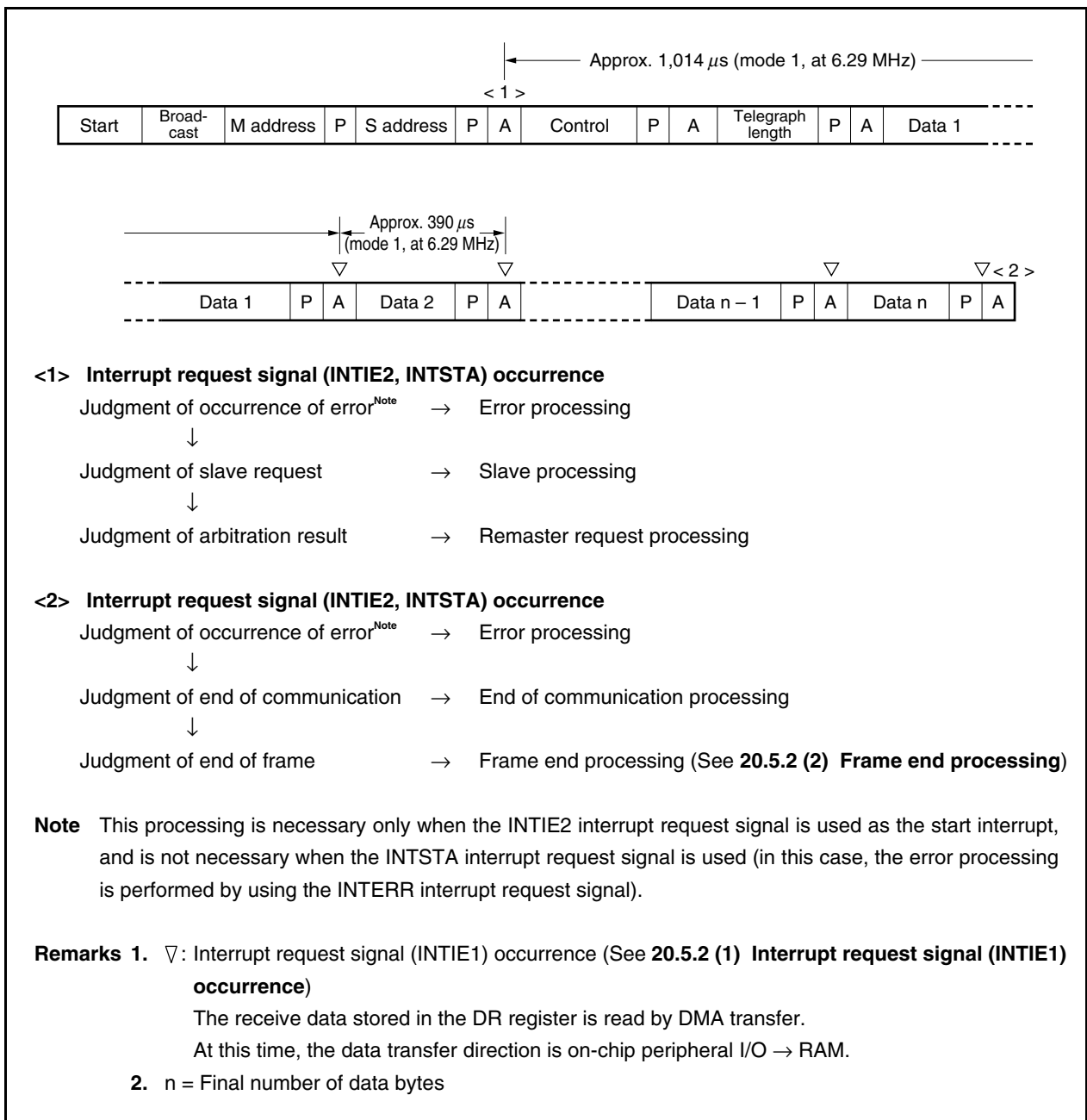

**(1) Interrupt request signal (INTIE1) occurrence**

If the NACK signal is transmitted (hardware processing) in the data field, an interrupt request signal (INTIE1) is not issued to the INTC, and the same data is retransmitted from the slave.

If the receive data is not read by the time the next data is received, the hardware automatically transmits the NACK signal.

**(2) Frame end processing**

In the vector interrupt servicing in <2>, it is judged whether the data has been correctly received within one frame. If the data has not been correctly received (if the number of data to be received in one frame could not be received), a request to retransmit the data must be made to the slave in the next communication frame.

### 20.5.3 Slave transmission

Initial preparation processing:

Set a unit address, telegraph length, and the first byte of the transmit data.

Communication start processing:

Set the BCR register (enable communication, slave transmission, and slave reception).

Figure 20-28. Slave Transmission

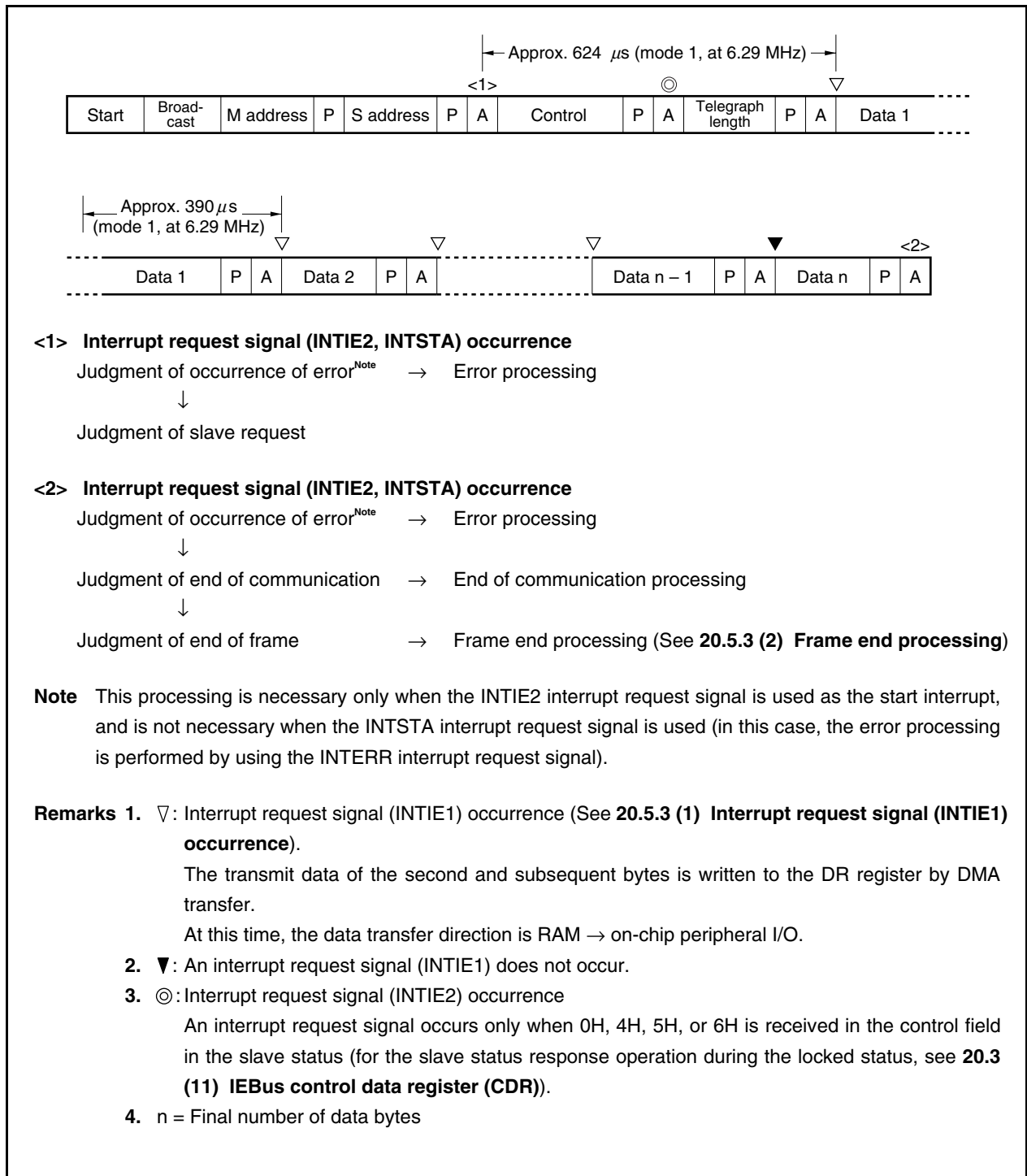

**(1) Interrupt request signal (INTIE1) occurrence**

If the NACK signal is received from the master in the data field, an interrupt request signal (INTIE1) is not issued to the INTC, and the same data is retransmitted by hardware.

If the transmit data is not written in time during the period of writing the next data, a communication error interrupt request signal (INTERR) occurs due to occurrence of underrun, and communication is abnormally ended.

**(2) Frame end processing**

In the vector interrupt servicing in <2>, it is judged whether the data has been correctly transmitted within one frame. If the data has not been correctly transmitted (if the number of data to be transmitted in one frame could not be transmitted), the data must be retransmitted in the next frame, or the remaining data must be transmitted.

20.5.4 Slave reception

Initial preparation processing:

Set a unit address.

Communication start processing:

Set the BCR register (enable communication, disables slave transmission, and enables slave reception).

Figure 20-29. Slave Reception

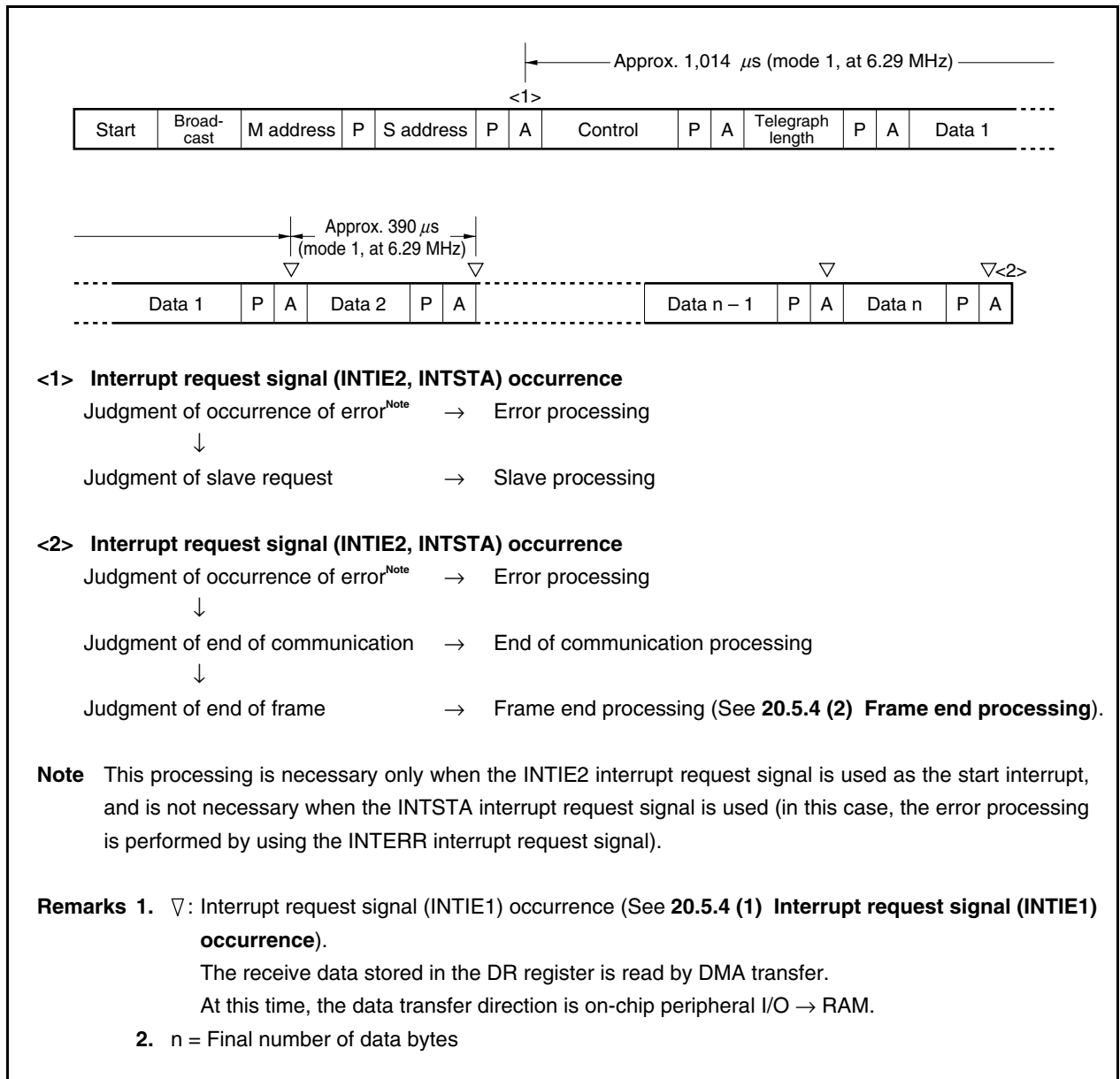

**(1) Interrupt request signal (INTIE1) occurrence**

If the NACK signal is transmitted in the data field, an interrupt request signal (INTIE1) is not issued to the INTC, and the same data is retransmitted from the master.

If the receive data is not read by the time the next data is received, the NACK signal is automatically transmitted.

**(2) Frame end processing**

In the vector interrupt servicing in <2>, it is judged whether the data has been correctly received within one frame.

**20.5.5 Interval of occurrence of interrupt request signal for IEBus control**

Each control interrupt request signal must occur at each point of communication and perform the necessary processing until the next interrupt request signal occurs. Therefore, the IEBus control block is controlled by software, taking the shortest time of this interrupt request signal occurrence interval into consideration.

The locations at which the following interrupt request signals may occur are indicated by  $\uparrow$  in the field where it may occur.  $\uparrow$  does not mean that the interrupt request signal occurs at each of the points indicated by  $\uparrow$ . If an error interrupt request signal (timing error, parity error, or NACK receive error) occurs, the IEBus internal circuit is initialized. As a result, the following interrupt request signal does not occur in that communication frame.

**(1) Master transmission**

**Figure 20-30. Master Transmission (Interval of Interrupt Request Signal Occurrence)**

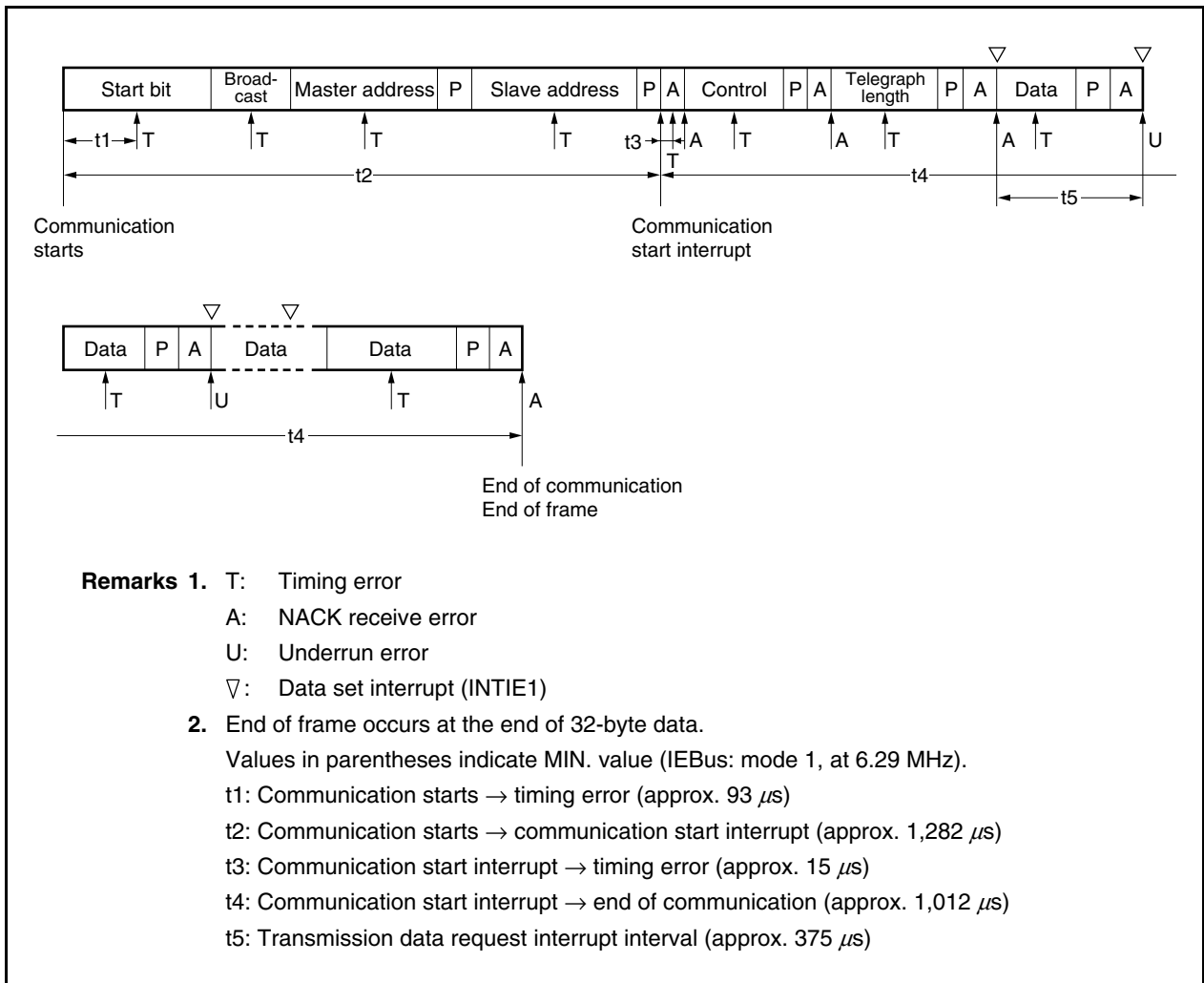

(2) Master reception

Figure 20-31. Master Reception (Interval of Interrupt Request Signal Occurrence)

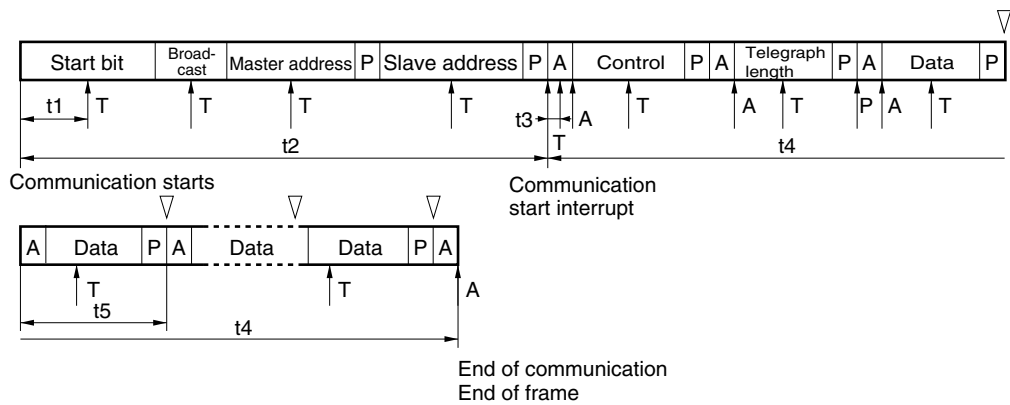

**Remarks 1.** T: Timing error

P: Parity error

A: NACK receive error

▽: Data set interrupt (INTIE1)

**2.** End of frame occurs at the end of 32-byte data.

Values in parentheses indicate MIN. value (IEBus: mode 1, at 6.29 MHz).

t1: Communication starts → timing error (approx. 93  $\mu$ s)

t2: Communication starts → communication start interrupt (approx. 1,282  $\mu$ s)

t3: Communication start interrupt → timing error (approx. 15  $\mu$ s)

t4: Communication start interrupt → end of communication (approx. 1,012  $\mu$ s)

t5: Receive data read interval (approx. 375  $\mu$ s)



(3) Slave transmission

Figure 20-32. Slave Transmission (Interval of Interrupt Request Signal Occurrence)

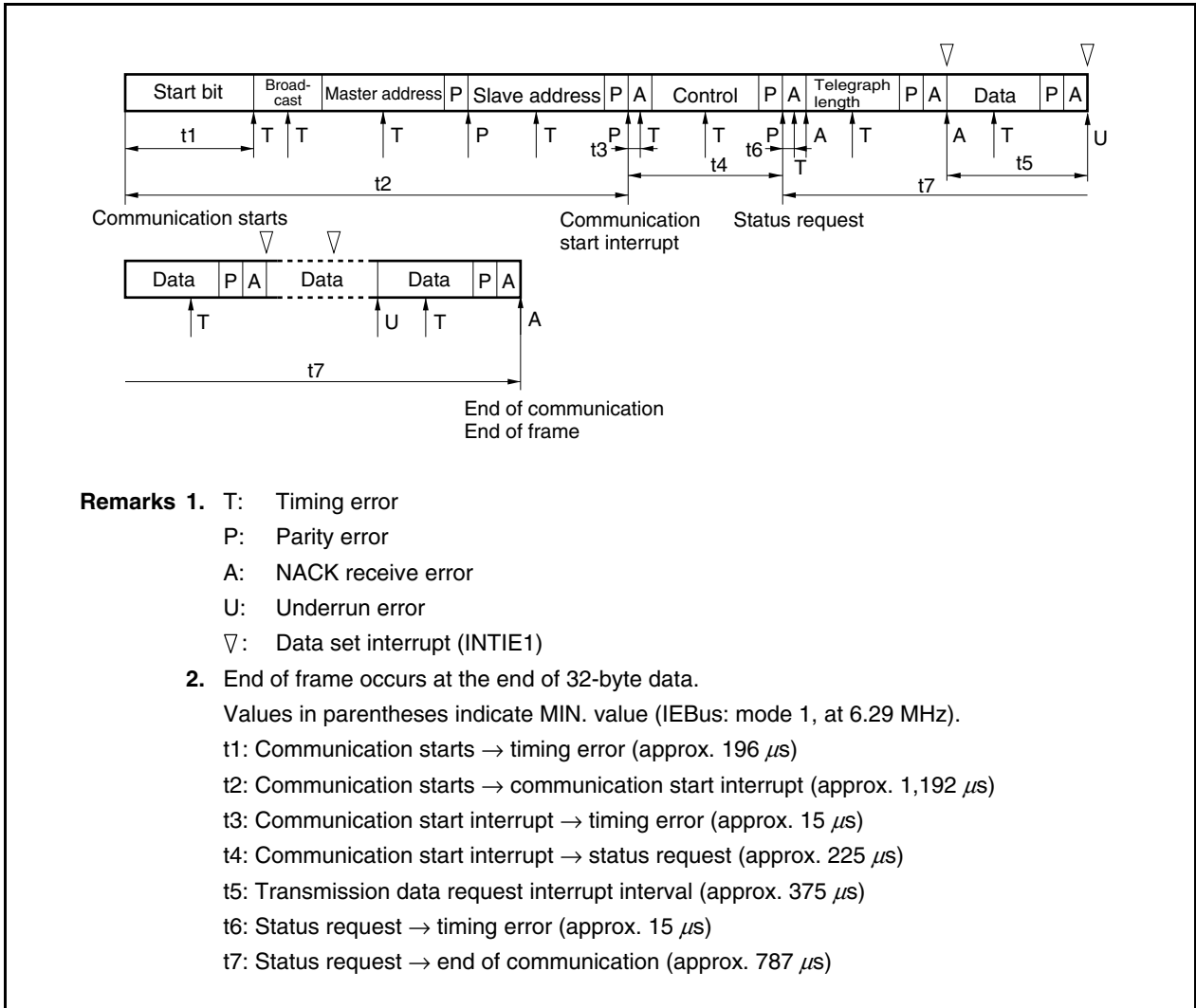

(4) Slave reception

Figure 20-33. Slave Reception (Interval of Interrupt Request Signal Occurrence)

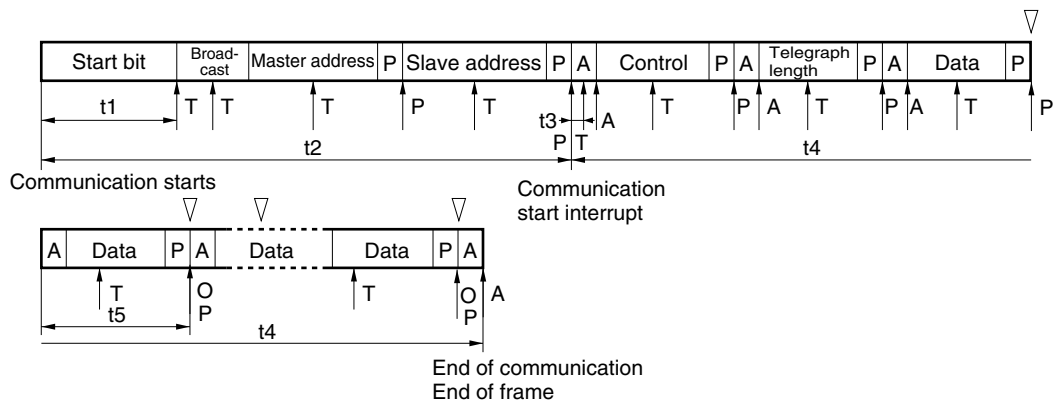

**Remarks 1.** T: Timing error

P: Parity error

A: NACK receive error

O: Overrun error

▽: Data set interrupt (INTIE1)

**2.** End of frame occurs at the end of 32-byte data.

Values in parentheses indicate MIN. value (IEBus: mode 1, at 6.29 MHz).

t1: Communication starts → timing error (approx. 196  $\mu$ s)

t2: Communication starts → communication start interrupt (approx. 1,192  $\mu$ s)

t3: Communication start interrupt → timing error (approx. 15  $\mu$ s)

t4: Communication start interrupt → end of communication (approx. 1,012  $\mu$ s)

t5: Receive data read interval (approx. 375  $\mu$ s)

## 20.6 Caution

<R> **(1) Switching DMA transfer start factor**  
In the V850E/SJ3-H and V850E/SK3-H, the INTERR and INTCE0T signals<sup>Note</sup>, and INTSTA and INTCE1T signals<sup>Note</sup>, which are the DMA transfer start factors, respectively share the same pin, and they cannot be used at the same time. To use INTERR or INTSTA signal as the DMA transfer start factor, set the DTFROB0 bit of the option byte 0000007AH to 0 (see **CHAPTER 33 OPTION BYTE FUNCTION**). In this case, the INTCE0T<sup>Note</sup> and INTCE1T<sup>Note</sup> signals cannot be used as the DMA transfer start factor.

<R> **Note** Not available in the  $\mu$ PD70F3931 (V850E/SJ3-H), 70F3932 (V850E/SJ3-H), and 70F3933 (V850E/SJ3-H)

**Remark** For details, see **Table 22-1 DMA Transfer Start Factors**.

## CHAPTER 21 CAN CONTROLLER

**Caution** The CAN controller is allocated in the programmable peripheral I/O area.  
Before using the CAN controller, enable use of the programmable peripheral I/O area by using the BPC register.  
For details, refer to 3.4.7 Programmable peripheral I/O registers.

### 21.1 Overview

The V850E/SJ3-H and V850E/SK3-H feature an on-chip 1-channel or 2-channel CAN (Controller Area Network) controller that complies with the CAN protocol as standardized in ISO 11898.

The V850E/SJ3-H and V850E/SK3-H products with an on-chip CAN controller are as follows.

- <R>
- $\mu$ PD70F3475, 70F3476, 70F3478, 70F3479, 70F3481, 70F3482, 70F3487, 70F3488, 70F3926, 70F3927, 70F3932, 70F3933, 70F3935, 70F3936, 70F3938, 70F3939

The V850E/SJ3-H and V850E/SK3-H products with an on-chip 2-channel CAN controller are as follows.

- <R>
- $\mu$ PD70F3476, 70F3479, 70F3482, 70F3488, 70F3927, 70F3933, 70F3936, 70F3939

#### 21.1.1 Features

- Compliant with ISO 11898 and tested according to ISO/DIS 16845 (CAN conformance test)
- Standard frame and extended frame transmission/reception enabled
- Transfer rate: 1 Mbps max. (CAN clock input  $\geq$  8 MHz)
- 32 message buffers/channels
- Receive/transmit history list function
- Automatic block transmission function
- Multi-buffer receive block function
- Mask setting of four patterns is possible for each channel

### 21.1.2 Overview of functions

Table 21-1 presents an overview of the CAN controller functions.

**Table 21-1. Overview of Functions**

Function	Details
Protocol	CAN protocol ISO 11898 (standard and extended frame transmission/reception)
Baud rate	Maximum 1 Mbps (CAN clock input $\geq$ 8 MHz)
Data storage	Storing messages in the CAN RAM
Number of messages	<ul style="list-style-type: none"> <li>• 32 message buffers/channels</li> <li>• Each message buffer can be set to be either a transmit message buffer or a receive message buffer.</li> </ul>
Message reception	<ul style="list-style-type: none"> <li>• Unique ID can be set to each message buffer.</li> <li>• Mask setting of four patterns is possible for each channel.</li> <li>• A receive completion interrupt is generated each time a message is received and stored in a message buffer.</li> <li>• Two or more receive message buffers can be used as a FIFO receive buffer (multi-buffer receive block function).</li> <li>• Receive history list function</li> </ul>
Message transmission	<ul style="list-style-type: none"> <li>• Unique ID can be set to each message buffer.</li> <li>• Transmit completion interrupt for each message buffer</li> <li>• Message buffer numbers 0 to 7 specified as transmit message buffers can be used for automatic block transfer. Message transmission interval is programmable (automatic block transmission function (hereafter referred to as "ABT")).</li> <li>• Transmission history list function</li> </ul>
Remote frame processing	Remote frame processing by transmit message buffer
Time stamp function	<ul style="list-style-type: none"> <li>• The time stamp function can be set for a receive message when a 16-bit timer is used in combination.</li> <li>• The time stamp capture trigger can be selected (SOF or EOF in a CAN message frame can be detected).</li> </ul>
Diagnostic function	<ul style="list-style-type: none"> <li>• Readable error counters</li> <li>• "Valid protocol operation flag" for verification of bus connections</li> <li>• Receive-only mode</li> <li>• Single-shot mode</li> <li>• CAN protocol error type decoding</li> <li>• Self-test mode</li> </ul>
Release from bus-off state	<ul style="list-style-type: none"> <li>• Can be forcibly released from bus-off by software (timing restrictions are ignored).</li> <li>• Cannot be automatically released from bus-off (release request by software is required).</li> </ul>
Power save mode	<ul style="list-style-type: none"> <li>• CAN sleep mode (can be woken up by CAN bus)</li> <li>• CAN stop mode (cannot be woken up by CAN bus)</li> </ul>

21.1.3 Configuration

The CAN controller is composed of the following four blocks.

(1) NPB interface

This functional block provides an NPB (NEC Peripheral I/O Bus) interface and means of transmitting and receiving signals between the CAN module and the host CPU.

(2) MCM (Memory Control Module)

This functional block controls access to the CAN protocol layer and to the CAN RAM within the CAN module.

(3) CAN protocol layer

This functional block is involved in the operation of the CAN protocol and its related settings.

(4) CAN RAM

This is the CAN memory functional block, which is used to store message IDs, message data, etc.

Figure 21-1. Block Diagram of CAN Module

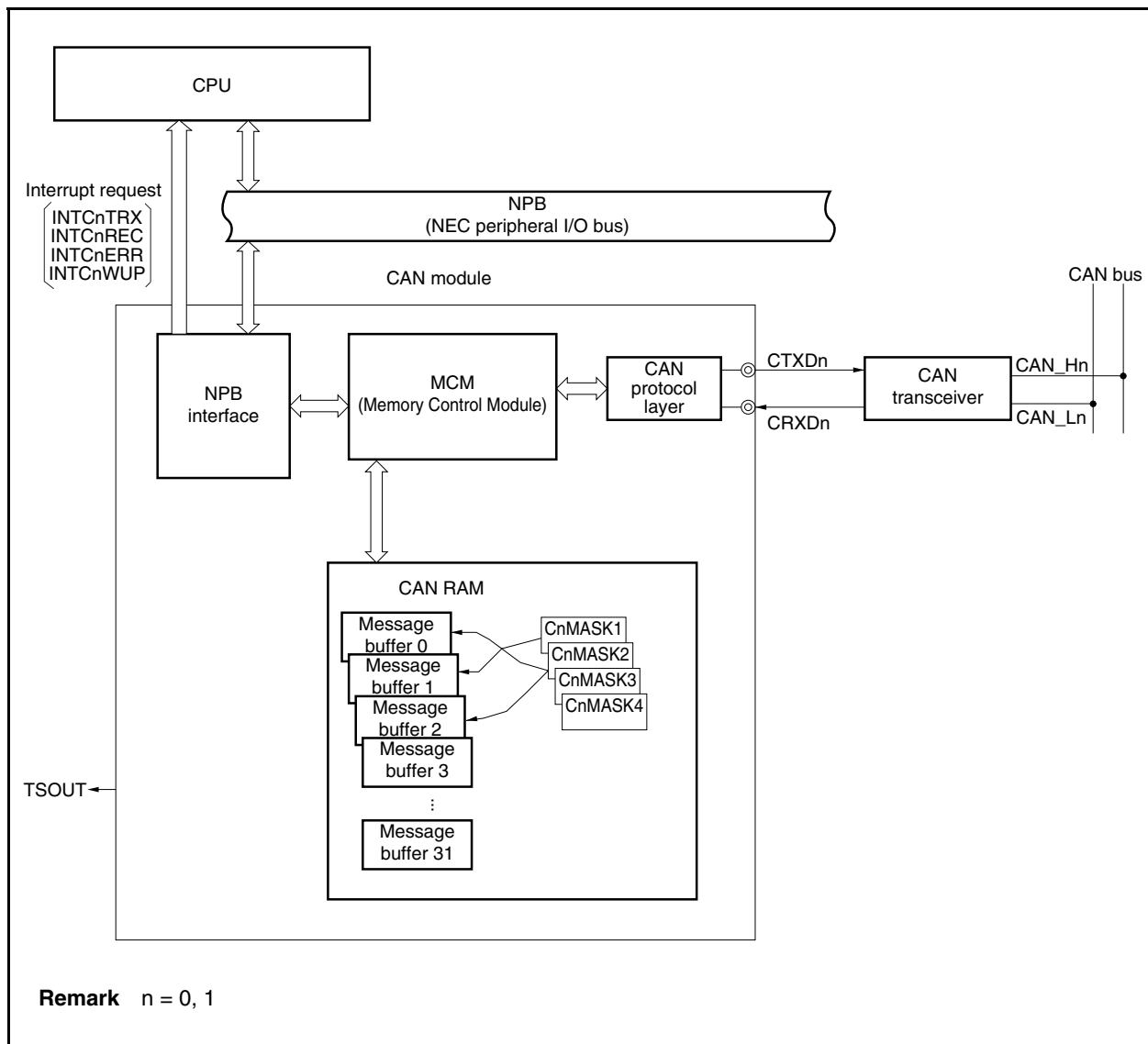

## 21.2 CAN Protocol

CAN (Controller Area Network) is a high-speed multiplex communication protocol for real-time communication in automotive applications (class C). CAN is prescribed by ISO 11898. For details, refer to the ISO 11898 specifications.

The CAN specification is generally divided into two layers: a physical layer and a data link layer. In turn, the data link layer includes logical link and medium access control. The composition of these layers is illustrated below.

**Figure 21-2. Composition of Layers**

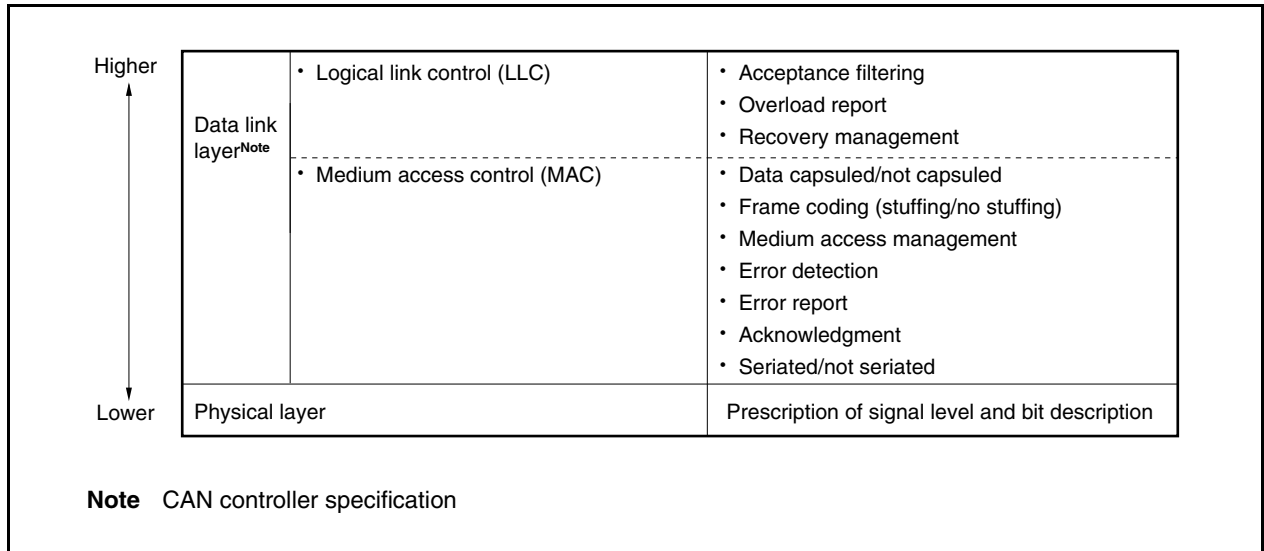

### 21.2.1 Frame format

**(1) Standard format frame**

- The standard format frame uses 11-bit identifiers, which means that it can handle up to 2,048 messages.

**(2) Extended format frame**

- The extended format frame uses 29-bit (11 bits + 18 bits) identifiers, which increases the number of messages that can be handled to  $2,048 \times 2^{18}$  messages.
- An extended format frame is set when “recessive level” (CMOS level of “1”) is set for both the SRR and IDE bits in the arbitration field.

21.2.2 Frame types

The following four types of frames are used in the CAN protocol.

Table 21-2. Frame Types

Frame Type	Description
Data frame	Frame used to transmit data
Remote frame	Frame used to request a data frame
Error frame	Frame used to report error detection
Overload frame	Frame used to delay the next data frame or remote frame

(1) Bus value

The bus values are divided into dominant and recessive.

- Dominant level is indicated by logical 0.
- Recessive level is indicated by logical 1.
- When a dominant level and a recessive level are transmitted simultaneously, the bus value becomes dominant level.

21.2.3 Data frame and remote frame

(1) Data frame

A data frame is composed of seven fields.

Figure 21-3. Data Frame

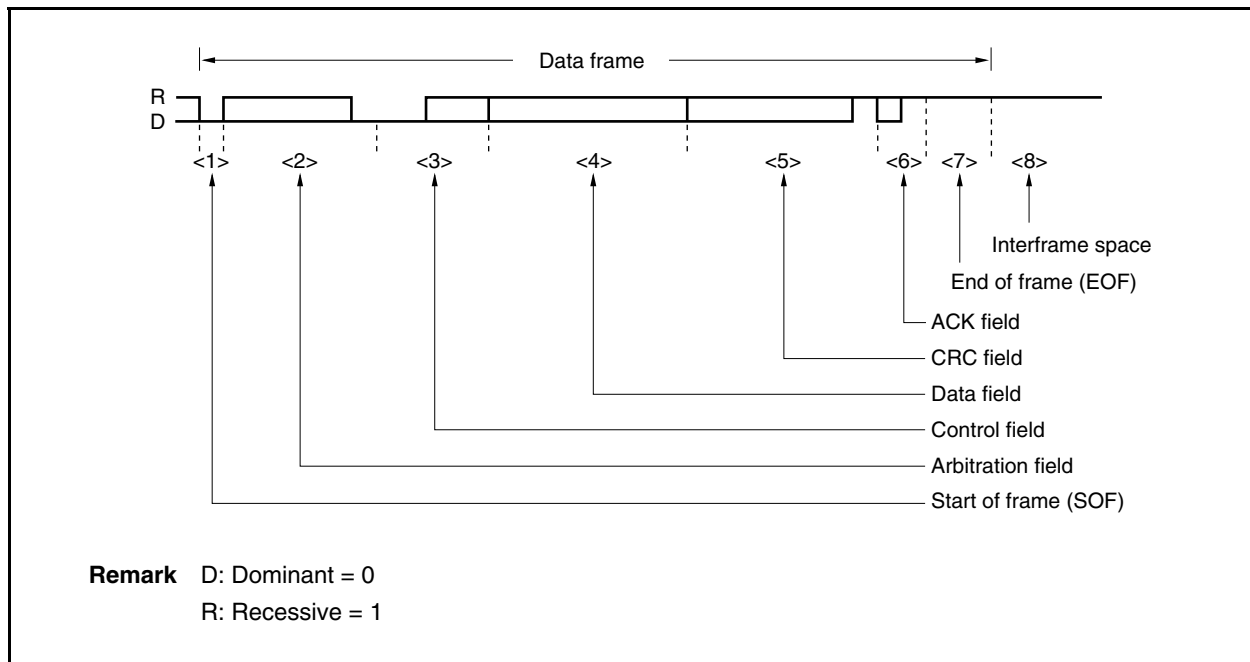



**(2) Remote frame**

A remote frame is composed of six fields.

**Figure 21-4. Remote Frame**

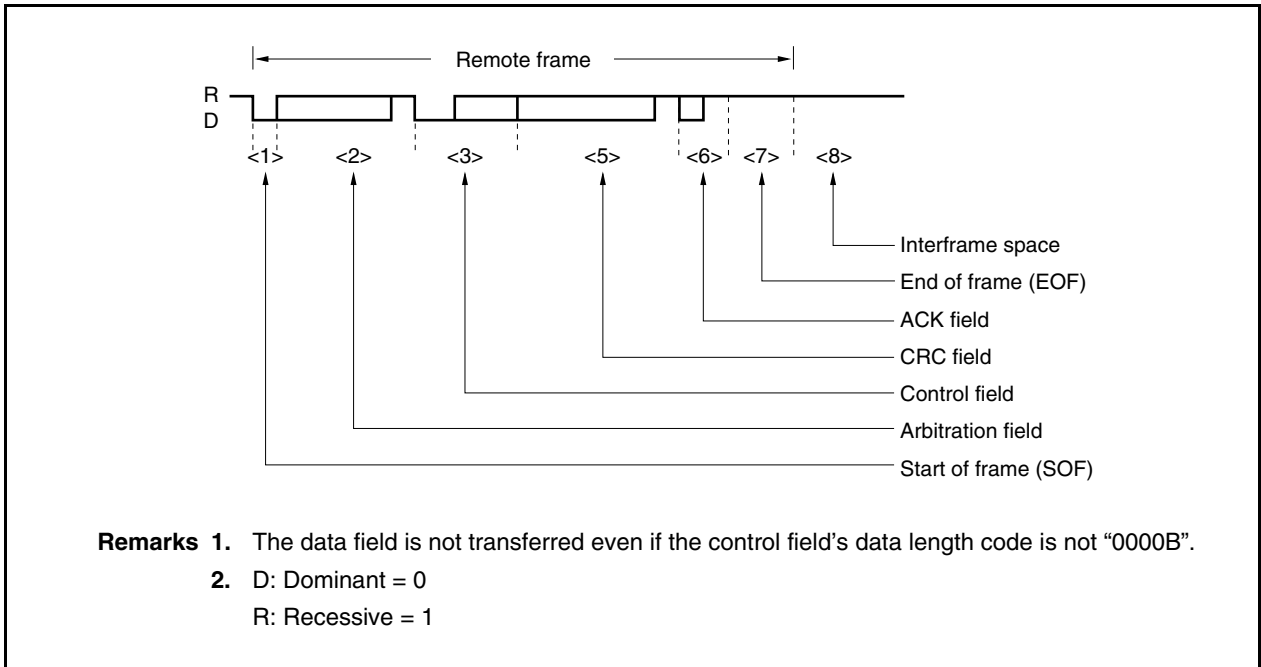

**(3) Description of fields**

**<1> Start of frame (SOF)**

The start of frame field is located at the start of a data frame or remote frame.

**Figure 21-5. Start of Frame (SOF)**

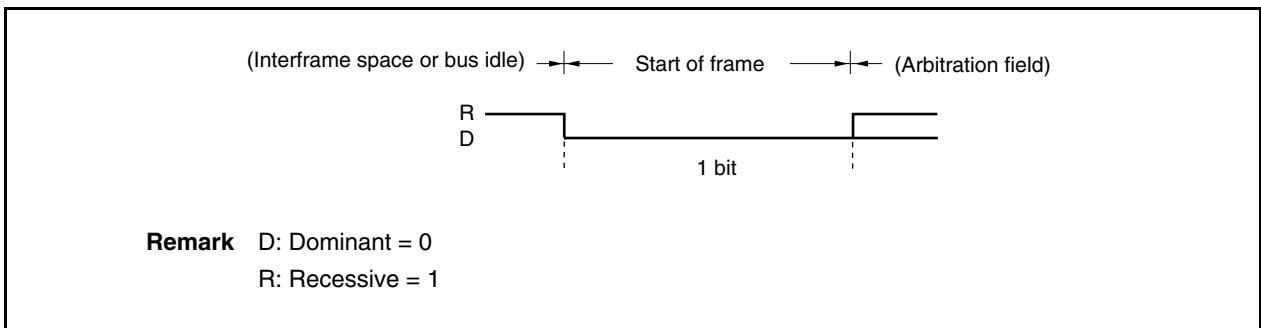

- If a dominant level is detected in the bus idle state, a hardware synchronization is performed (the current TQ is assigned to be the SYNC segment).
- If a dominant level is sampled at the sample point following such a hardware synchronization, the bit is assigned to be a SOF. If a recessive level is detected, the protocol layer returns to the bus idle state and regards the preceding dominant pulse as a noise only. In this case an error frame is not generated.

<2> Arbitration field

The arbitration field is used to set the priority, data frame/remote frame, and frame format.

Figure 21-6. Arbitration Field (in Standard Format Mode)

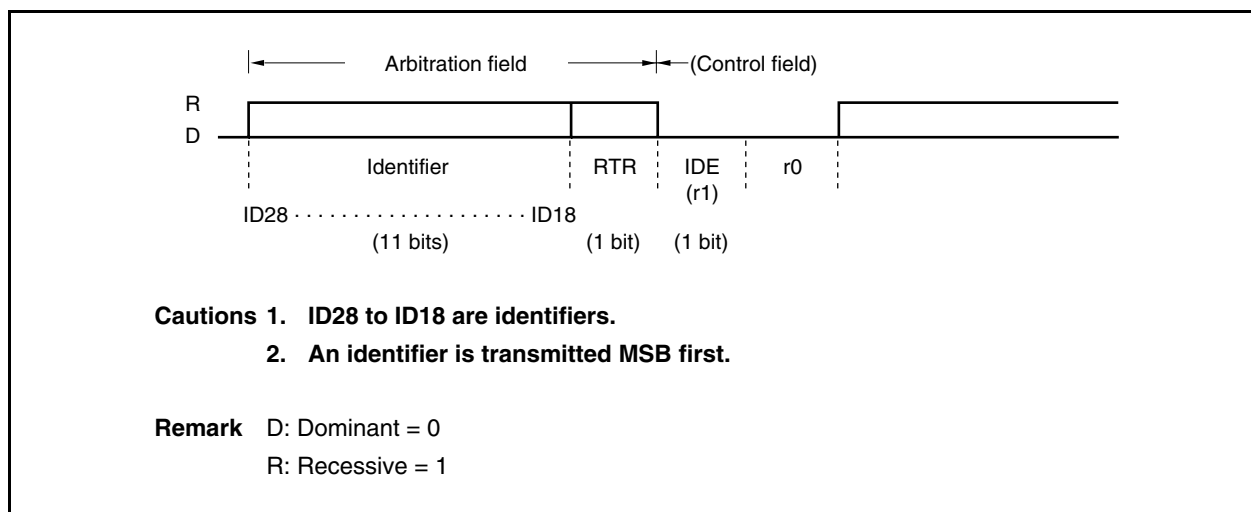

Figure 21-7. Arbitration Field (in Extended Format Mode)

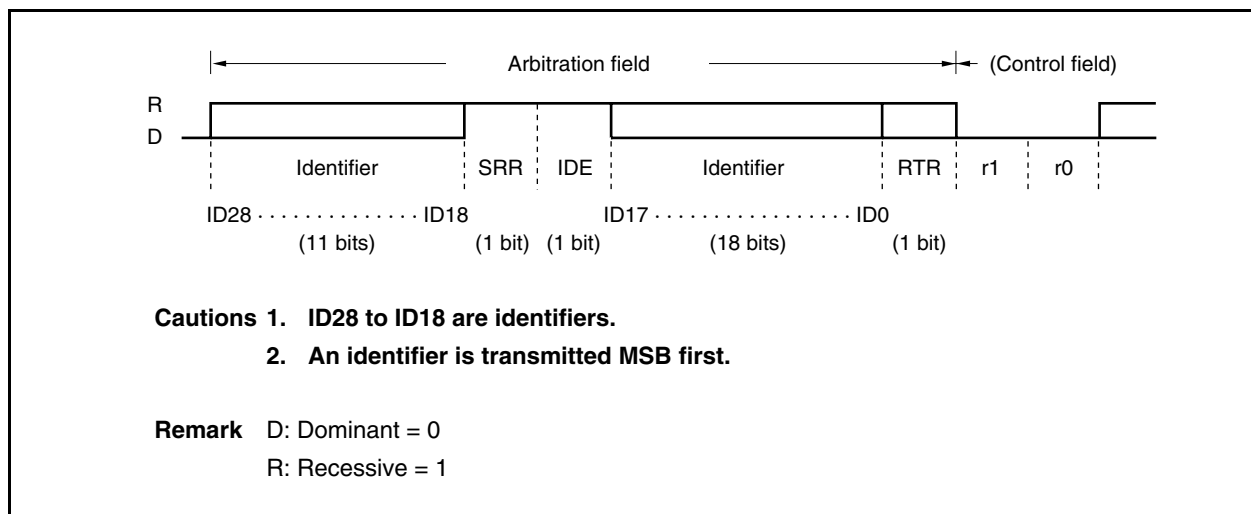

Table 21-3. RTR Frame Settings

Frame Type	RTR Bit
Data frame	0 (D)
Remote frame	1 (R)

Table 21-4. Frame Format Setting (IDE Bit) and Number of Identifier (ID) Bits

Frame Format	SRR Bit	IDE Bit	Number of Bits
Standard format mode	None	0 (D)	11 bits
Extended format mode	1 (R)	1 (R)	29 bits

<3> Control field

The control field sets “DLC” as the number of data bytes in the data field (DLC = 0 to 8).

Figure 21-8. Control Field

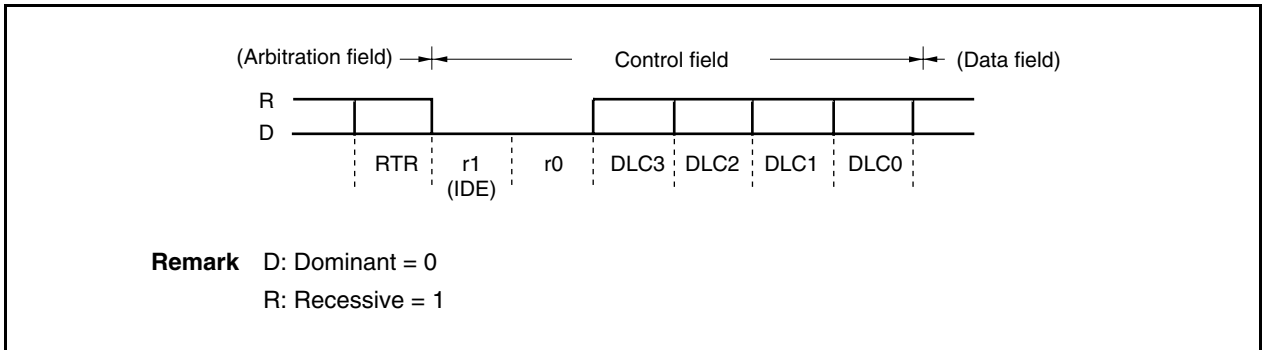

In a standard format frame, the control field's IDE bit is the same as the r1 bit.

Table 21-5. Data Length Setting

Data Length Code				Data Byte Count
DLC3	DLC2	DLC1	DLC0	
0	0	0	0	0 bytes
0	0	0	1	1 byte
0	0	1	0	2 bytes
0	0	1	1	3 bytes
0	1	0	0	4 bytes
0	1	0	1	5 bytes
0	1	1	0	6 bytes
0	1	1	1	7 bytes
1	0	0	0	8 bytes
Other than above				8 bytes regardless of the value of DLC3 to DLC0

**Caution** In the remote frame, there is no data field even if the data length code is not 0000B.

<4> **Data field**

The data field contains the amount of data (byte units) set by the control field. Up to 8 units of data can be set.

**Figure 21-9. Data Field**

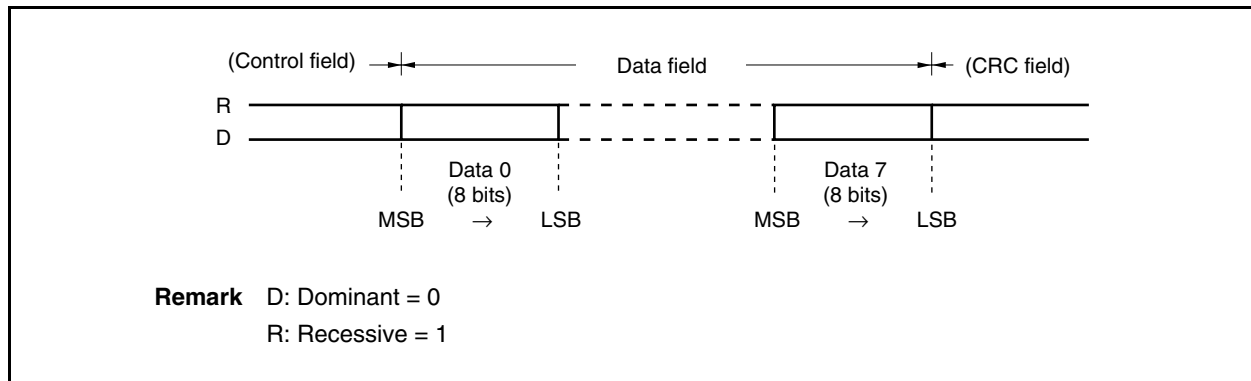

<5> **CRC field**

The CRC field is a 16-bit field that is used to check for errors in transmit data.

**Figure 21-10. CRC Field**

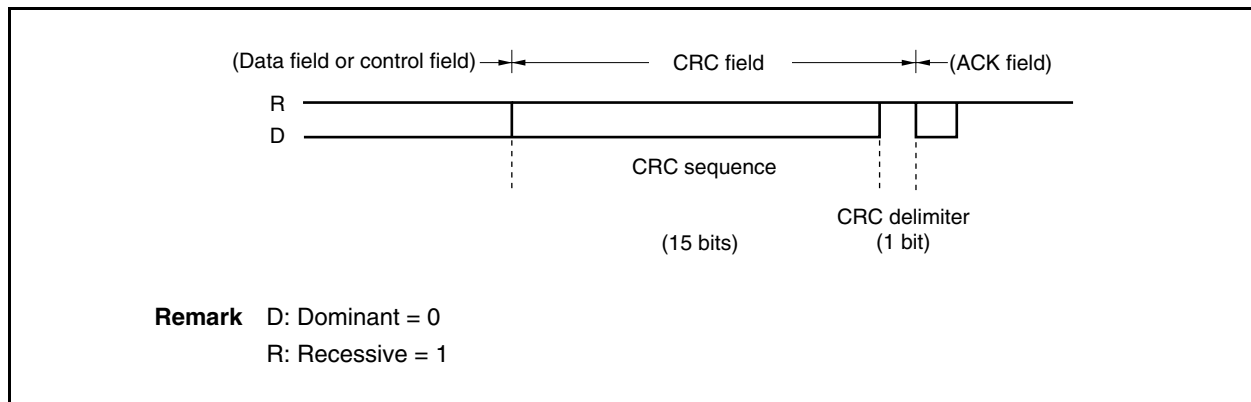

- The polynomial  $P(X)$  used to generate the 15-bit CRC sequence is expressed as follows.  

$$P(X) = X^{15} + X^{14} + X^{10} + X^8 + X^7 + X^4 + X^3 + 1$$
- Transmitting node: Transmits the CRC sequence calculated from the data (before bit stuffing) in the start of frame, arbitration field, control field, and data field.
- Receiving node: Compares the CRC sequence calculated using data bits that exclude the stuffing bits in the receive data with the CRC sequence in the CRC field. If the two CRC sequences do not match, the node issues an error frame.

<6> **ACK field**

The ACK field is used to acknowledge normal reception.

**Figure 21-11. ACK Field**

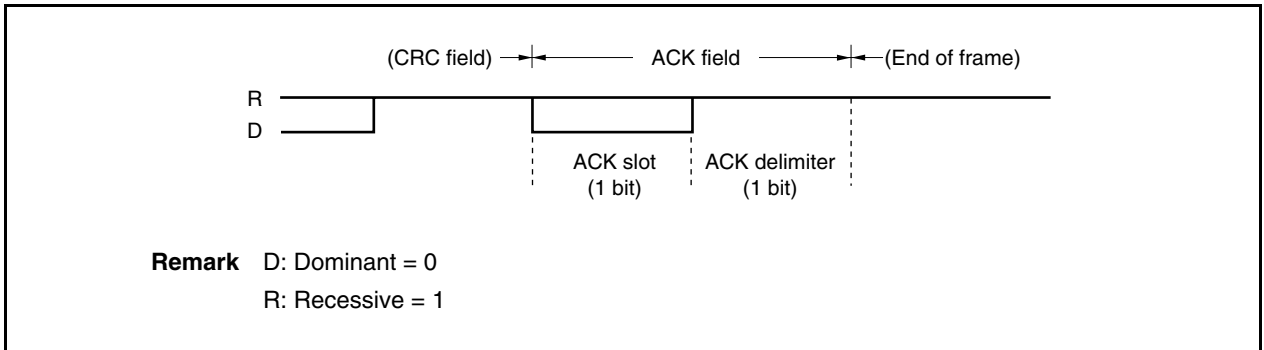

- If no CRC error is detected, the receiving node sets the ACK slot to the dominant level.
- The transmitting node outputs two recessive-level bits.

<7> **End of frame (EOF)**

The end of frame field indicates the end of data frame/remote frame.

**Figure 21-12. End of Frame (EOF)**

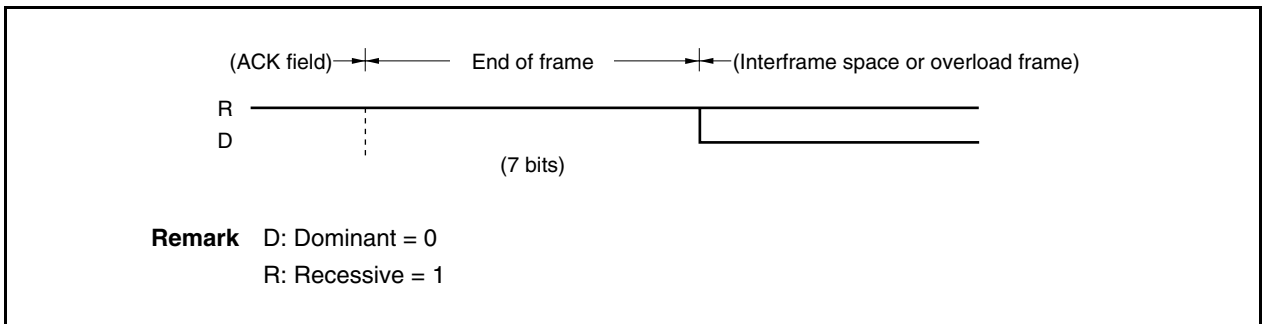

<8> **Interframe space**

The interframe space is inserted after a data frame, remote frame, error frame, or overload frame to separate one frame from the next.

- The bus state differs depending on the error status.

**(a) Error active node**

The interframe space consists of a 3-bit intermission field and a bus idle field.

**Figure 21-13. Interframe Space (Error Active Node)**

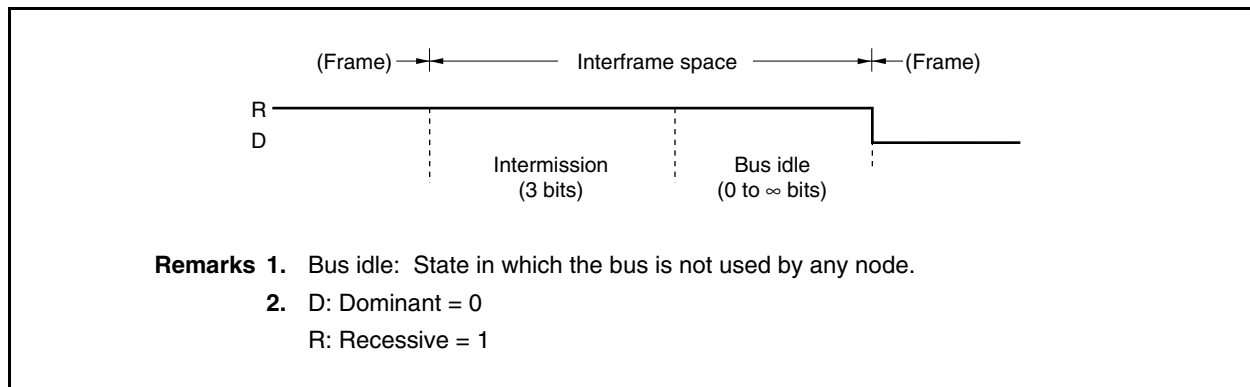

**(b) Error passive node**

The interframe space consists of an intermission field, a suspend transmission field, and a bus idle field.

**Figure 21-14. Interframe Space (Error Passive Node)**

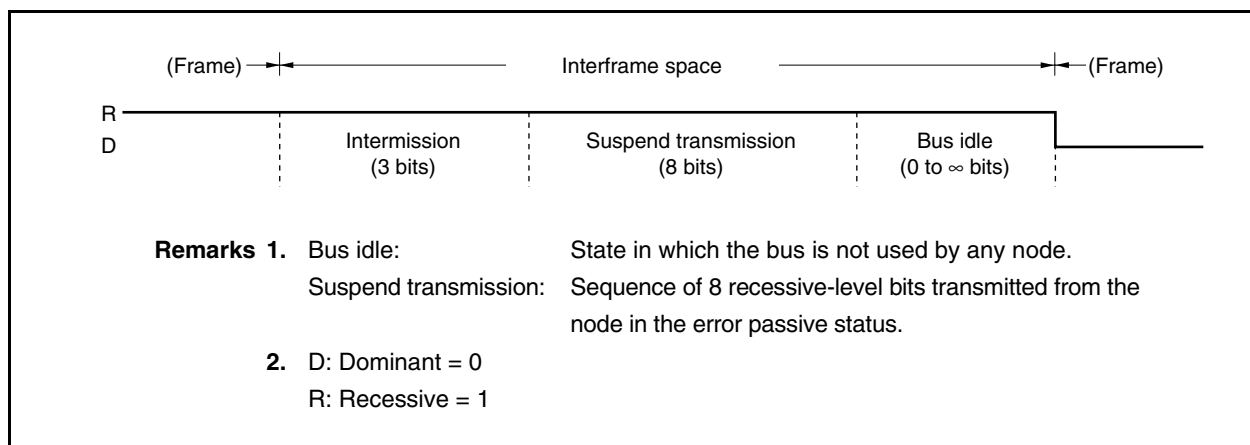

Usually, the intermission field is 3 bits. If the transmitting node detects a dominant level at the third bit of the intermission field, however, it executes transmission.

- Operation in error status

**Table 21-6. Operation in Error Status**

Error Status	Operation
Error active	A node in this status can transmit immediately after a 3-bit intermission.
Error passive	A node in this status can transmit 8 bits after the intermission.

21.2.4 Error frame

An error frame is output by a node that has detected an error.

Figure 21-15. Error Frame

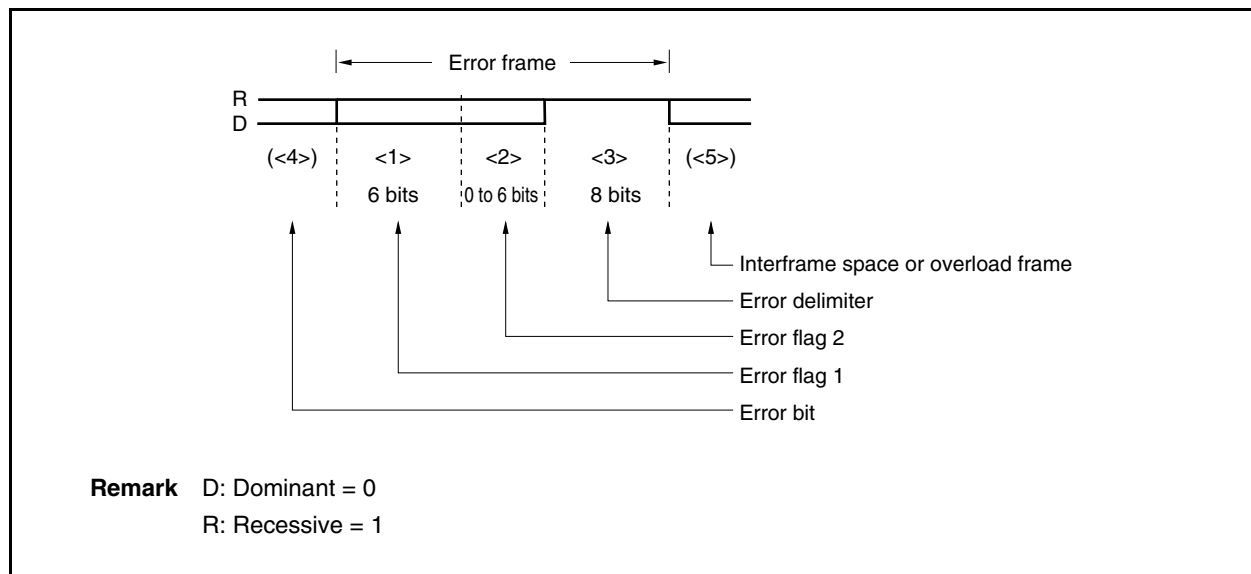

Table 21-7. Definition of Error Frame Fields

No.	Name	Bit Count	Definition
<1>	Error flag 1	6	Error active node: Outputs 6 dominant-level bits consecutively. Error passive node: Outputs 6 recessive-level bits consecutively. If another node outputs a dominant level while one node is outputting a passive error flag, the passive error flag is not cleared until the same level is detected 6 bits in a row.
<2>	Error flag 2	0 to 6	Nodes receiving error flag 1 detect bit stuff errors and issues this error flag.
<3>	Error delimiter	8	Outputs 8 recessive-level bits consecutively. If a dominant level is detected at the 8th bit, an overload frame is transmitted from the next bit.
<4>	Error bit	-	The bit at which the error was detected. The error flag is output from the bit next to the error bit. In the case of a CRC error, this bit is output following the ACK delimiter.
<5>	Interframe space/overload frame	-	An interframe space or overload frame starts from here.



**21.2.5 Overload frame**

An overload frame is transmitted under the following conditions.

- When the receiving node has not completed the reception operation<sup>Note</sup>
- If a dominant level is detected at the first two bits during intermission
- If a dominant level is detected at the last bit (7th bit) of the end of frame or at the last bit (8th bit) of the error delimiter/overload delimiter

**Note** In this CAN controller, all reception frames can be loaded without outputting an overload frame because of the enough high-speed internal processing.

**Figure 21-16. Overload Frame**

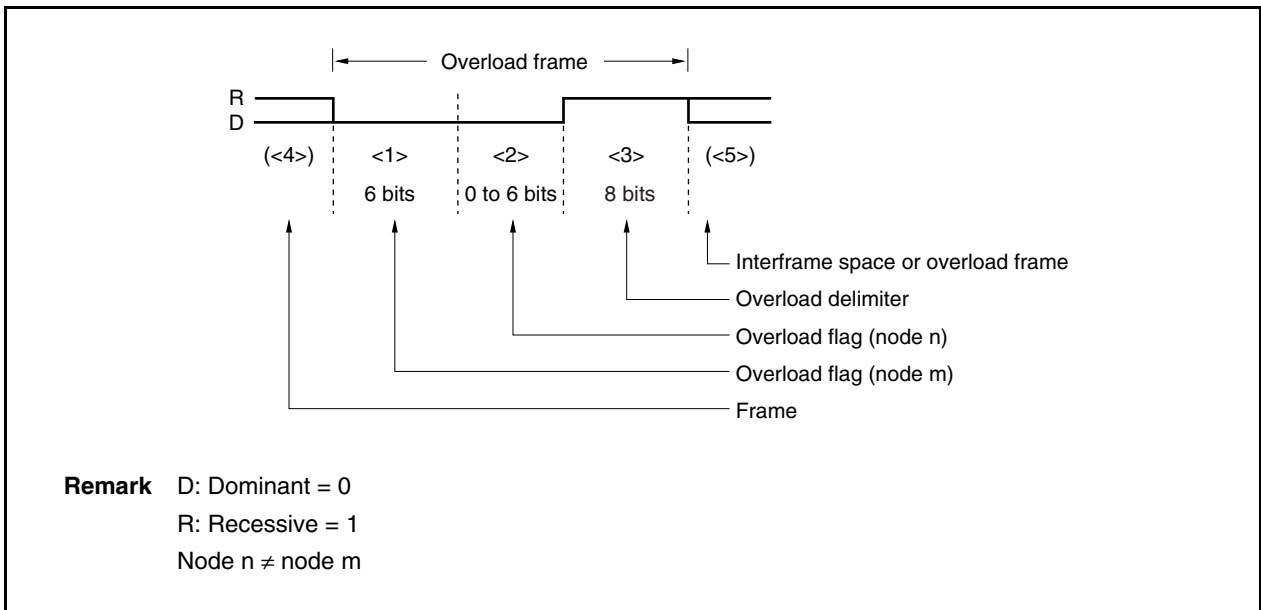

**Table 21-8. Definition of Overload Frame Fields**

No	Name	Bit Count	Definition
<1>	Overload flag	6	Outputs 6 dominant-level bits consecutively.
<2>	Overload flag from other node	0 to 6	The node that received an overload flag in the interframe space outputs an overload flag.
<3>	Overload delimiter	8	Outputs 8 recessive-level bits consecutively. If a dominant level is detected at the 8th bit, an overload frame is transmitted from the next bit.
<4>	Frame	–	Output following an end of frame, error delimiter, or overload delimiter.
<5>	Interframe space/overload frame	–	An interframe space or overload frame starts from here.

## 21.3 Functions

### 21.3.1 Determining bus priority

**(1) When a node starts transmission:**

- During bus idle, the node that output data first transmits the data.

**(2) When more than one node starts transmission:**

- The node that consecutively outputs the dominant level for the longest from the first bit of the arbitration field has the bus priority (if a dominant level and a recessive level are simultaneously transmitted, the dominant level is taken as the bus value).
- The transmitting node compares its output arbitration field and the data level on the bus.

**Table 21-9. Determining Bus Priority**

Level match	Continuous transmission
Level mismatch	Continuous transmission

**(3) Priority of data frame and remote frame**

- When a data frame and a remote frame are on the bus, the data frame has priority because its RTR bit, the last bit in the arbitration field, carries a dominant level.

**Remark** If the extended-format data frame and the standard-format remote frame conflict on the bus (if ID28 to ID18 of both of them are the same), the standard-format remote frame takes priority.

### 21.3.2 Bit stuffing

Bit stuffing is used to establish synchronization by appending 1 bit of inverted-level data if the same level continues for 5 bits, in order to prevent a burst error.

**Table 21-10. Bit Stuffing**

Transmission	During the transmission of a data frame or remote frame, when the same level continues for 5 bits in the data between the start of frame and the ACK field, 1 inverted-level bit of data is inserted before the following bit.
Reception	During the reception of a data frame or remote frame, when the same level continues for 5 bits in the data between the start of frame and the ACK field, reception is continued after deleting the next bit.

### 21.3.3 Multi masters

As the bus priority (a node which acquires transmission rights) is determined by the identifier, any node can be the bus master.

### 21.3.4 Multi cast

Although there is one transmitting node, two or more nodes can receive the same data at the same time because the same identifier can be set to two or more nodes.

**21.3.5 CAN sleep mode/CAN stop mode function**

The CAN sleep mode/CAN stop mode function puts the CAN controller in waiting mode to achieve low power consumption.

The controller is woken up from the CAN sleep mode by bus operation but it is not woken up from the CAN stop mode by bus operation (the CAN stop mode is controlled by CPU access).

**21.3.6 Error control function**

**(1) Error types**

**Table 21-11. Error Types**

Type	Description of Error		Detection State	
	Detection Method	Detection Condition	Transmission/ Reception	Field/Frame
Bit error	Comparison of the output level and level on the bus	Mismatch of levels	Transmitting/ receiving node	Bit that is outputting data on the bus at the start of frame to end of frame, error frame and overload frame.
Stuff error	Check of the receive data at the stuff bit	6 consecutive bits of the same output level	Receiving node	Start of frame to CRC sequence
CRC error	Comparison of the CRC sequence generated from the receive data and the received CRC sequence	Mismatch of CRC	Receiving node	CRC field
Form error	Field/frame check of the fixed format	Detection of fixed format violation	Receiving node	CRC delimiter ACK field End of frame Error frame Overload frame
ACK error	Check of the ACK slot by the transmitting node	Detection of recessive level in ACK slot	Transmitting node	ACK slot

**(2) Output timing of error frame**

**Table 21-12. Output Timing of Error Frame**

Type	Output Timing
Bit error, stuff error, form error, ACK error	Error frame output is started at the timing of the bit following the detected error.
CRC error	Error frame output is started at the timing of the bit following the ACK delimiter.

**(3) Processing in case of error**

The transmission node re-transmits the data frame or remote frame after the error frame. (However, it does not re-transmit the frame in the single-shot mode.)

#### (4) Error state

##### (a) Types of error states

The following three types of error states are defined by the CAN specification.

- Error active
- Error passive
- Bus-off

These types of error states are classified by the values of the CnERC.TEC7 to CnERC.TEC0 bits (transmission error counter bits) and the CnERC.REC6 to CnERC.REC0 bits (reception error counter bits) as shown in Table 21-13.

The present error state is indicated by the CnINFO register.

When each error counter value becomes equal to or greater than the error warning level (96), the CnINFO.TECS0 or CnINFO.RECS0 bit is set to 1. In this case, the bus state must be tested because it is considered that the bus has a serious fault. An error counter value of 128 or more indicates an error passive state and the TECS1 or RECS1 bit is set to 1.

- If the value of the transmission error counter is greater than or equal to 256 (actually, the transmission error counter does not indicate a value greater than or equal to 256), the bus-off state is reached and the CnINFO.BOFF bit is set to 1.
- If only one node is active on the bus at startup (i.e., when the bus is connected only to the local station), ACK is not returned even if data is transmitted. Consequently, re-transmission of the error frame and data is repeated. In the error passive state, however, the transmission error counter is not incremented and the bus-off state is not reached.

**Remark** n = 0, 1

Table 21-13. Types of Error States

Type	Operation	Value of Error Counter	Indication of CnINFO Register	Operation Specific to Error State
Error active	Transmission	0 to 95	TECS1, TECS0 = 00	<ul style="list-style-type: none"> <li>Outputs an active error flag (6 consecutive dominant-level bits) on detection of the error.</li> </ul>
	Reception	0 to 95	RECS1, RECS0 = 00	
	Transmission	96 to 127	TECS1, TECS0 = 01	
	Reception	96 to 127	RECS1, RECS0 = 01	
Error passive	Transmission	128 to 255	TECS1, TECS0 = 11	<ul style="list-style-type: none"> <li>Outputs a passive error flag (6 consecutive recessive-level bits) on detection of the error.</li> <li>Transmits 8 recessive-level bits, in between transmissions, following an intermission (suspend transmission).</li> </ul>
	Reception	128 or more	RECS1, RECS0 = 11	
Bus-off	Transmission	256 or more (not indicated) <sup>Note</sup>	BOFF = 1, TECS1, TECS0 = 11	<ul style="list-style-type: none"> <li>Communication is not possible. However, when the frame is received, no messages are stored and the following operations are performed. <ul style="list-style-type: none"> <li>&lt;1&gt; TSOUT toggles.</li> <li>&lt;2&gt; REC is incremented/decremented.</li> <li>&lt;3&gt; VALID bit is set.</li> </ul> </li> <li>If the initialization mode is set, after request to transit to an operation mode other than the initialization mode, 11 consecutive recessive-level bits are generated 128 times, and then the error counter is reset to 0 and the error active state can be restored.</li> </ul>

**Note** The value of the transmit error counter (TEC) does not carry any meaning if BOFF has been set. If an error that increments the value of the transmission error counter by 8 while the counter value is in a range of 248 to 255 occurs, the counter is not incremented and the bus-off state is assumed.

**Remark** n = 0, 1

**(b) Error counter**

The error counter counts up when an error has occurred, and counts down upon successful transmission and reception. The error counter counts up immediately after error detection.

**Table 21-14. Error Counter**

State	Transmission Error Counter (TEC7 to TEC0 Bits)	Reception Error Counter (REC6 to REC0 Bits)
Receiving node detects an error (except bit error in the active error flag or overload flag).	No change	+1 (REPS bit = 0)
Receiving node detects dominant level following error flag of error frame.	No change	+8 (REPS bit = 0)
Transmitting node transmits an error flag. [As exceptions, the error counter does not change in the following cases.] <1> ACK error is detected in error passive state and dominant level is not detected while the passive error flag is being output. <2> A stuff error is detected in an arbitration field that transmitted a recessive level as a stuff bit, but a dominant level is detected.	+8	No change
Bit error detection while active error flag or overload flag is being output (error-active transmitting node)	+8	No change
Bit error detection while active error flag or overload flag is being output (error-active receiving node)	No change	+8 (REPS bit = 0)
When the node detects 14 consecutive dominant-level bits from the beginning of the active error flag or overload flag, and then subsequently detects 8 consecutive dominant-level bits. When the node detects 8 consecutive dominant levels after a passive error flag	+8 (transmitting)	+8 (receiving, REPS bit = 0)
When the transmitting node has completed transmission without error ( $\pm 0$ if error counter = 0)	-1	No change
When the receiving node has completed reception without error	No change	<ul style="list-style-type: none"> <li>• -1 (<math>1 \leq \text{REC6 to REC0} \leq 127</math>, REPS bit = 0)</li> <li>• <math>\pm 0</math> (REC6 to REC0 = 0, REPS bit = 0)</li> <li>• Any value of 119 to 127 is set (REPS bit = 1)</li> </ul>

**(c) Occurrence of bit error in intermission**

An overload frame is generated.

**Caution** If an error occurs, it is controlled according to the contents of the transmission error counter and reception error counter before the error occurred. The value of the error counter is incremented after the error flag has been output.

**(5) Recovery from bus-off state**

When the CAN module is in the bus-off state, the transmission pins (CTXDn) cut off from the CAN bus always output the recessive level.

The CAN module recovers from the bus-off state in the following bus-off recovery sequence.

- <1> Request to enter the CAN initialization mode
- <2> Request to enter a CAN operation mode
  - (a) Recovery operation through normal recovery sequence
  - (b) Forced recovery operation that skips recovery sequence

**(a) Recovery from bus-off state through normal recovery sequence**

The CAN module first issues a request to enter the initialization mode (refer to timing <1> in Figure 21-17). This request will be immediately acknowledged, and the C0CTRL.OPMODE2 to OPMODE0 bits are cleared to 000B. Processing such as analyzing the fault that has caused the bus-off state, re-defining the CAN module and message buffer using application software, or stopping the operation of the CAN module can be performed by clearing the CnGMCTRL.GOM bit to 0.

Next, the module requests to change the mode from the initialization mode to an operation mode (refer to timing <2> in Figure 21-17). This starts an operation to recover the CAN module from the bus-off state.

The conditions under which the module can recover from the bus-off state are defined by the CAN protocol ISO 11898, and it is necessary to detect 11 consecutive recessive-level bits more than 128 times.

At this time, the request to change the mode to an operation mode is held pending until the recovery conditions are satisfied. When the recovery conditions are satisfied (refer to timing <3> in Figure 21-17), the CAN module can enter the operation mode it has requested. Until the CAN module enters this operation mode, it stays in the initialization mode. Whether the CAN module has completed transition to any other operation mode can be confirmed by reading the OPMODE2 to OPMODE0 bits. Before transition to any other operation mode is completed, OPMODE2 to OPMODE0 bits = 000B is read.

During the bus-off period and bus-off recovery sequence, the CnINFO.BoFF bit stays set (to 1). In the bus-off recovery sequence, the reception error counter (CnERC.REC0 to CnERC.REC6) counts the number of times 11 consecutive recessive-level bits have been detected on the bus. Therefore, the recovery state can be checked by reading the REC0 to REC6 bits.

- Cautions**
1. **If a request to change the mode from the initialization mode to any operation mode to execute the bus-off recovery sequence again during a bus-off recovery sequence, the bus-off recovery sequence starts from the beginning and 11 contiguous recessive bits are counted 128 times again on the bus.**
  2. **In the bus-off recovery sequence, the REC0 to REC6 bits counts up (+1) each time 11 consecutive recessive-level bits have been detected. Even during the bus-off period, the CAN module can enter the CAN sleep mode or CAN stop mode. To be released from the bus-off state, the module must enter the initialization mode once. If the module is in the CAN sleep mode or CAN stop mode, however, it cannot directly enter the initialization mode. In this case, the bus off recovery sequence is started at the same time as the CAN sleep mode is released even without shifting to the initialization mode. In addition to clearing the CnCTRL.PSMODE1 and CnCTRL.PSMODE0 bits by software, the bus off recovery sequence is also started due to wakeup by dominant edge detection on the CAN bus (While the CAN clock is supplied, the CnCTRL.PSMODE0 bit must be cleared by software after a dominant edge is detected.)**

**Remark** n = 0, 1

Figure 21-17. Recovery from Bus-off State Through Normal Recovery Sequence

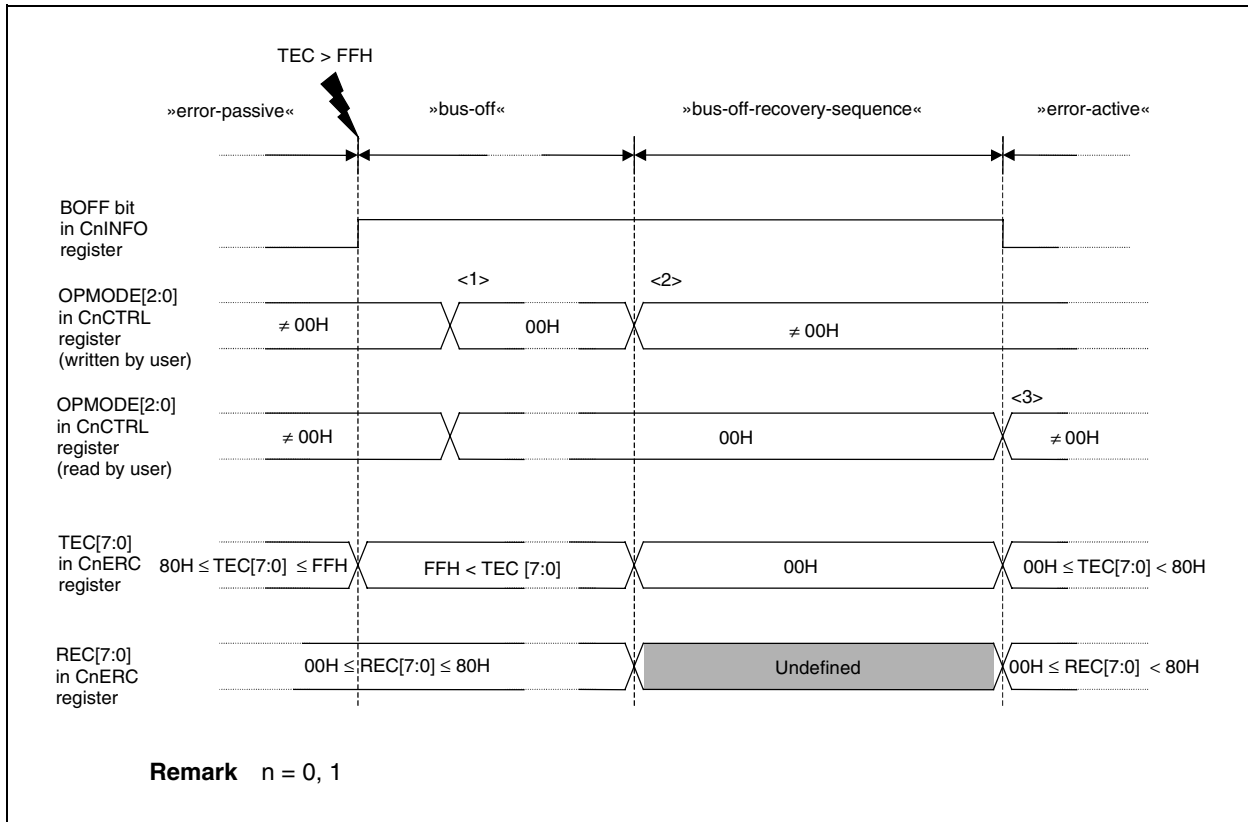

**(b) Forced recovery operation that skips bus-off recovery sequence**

The CAN module can be forcibly released from the bus-off state, regardless of the bus state, by skipping the bus-off recovery sequence. Here is the procedure.

First, the CAN module requests to enter the initialization mode. For the operation and points to be noted at this time, see 21.3.6 (5) (a) **Recovery from bus-off state through normal recovery sequence**.

Next, the module requests to enter an operation mode. At the same time, the CnCTRL.CCERC bit must be set to 1.

As a result, the bus-off recovery sequence defined by the CAN protocol ISO 11898 is skipped, and the module immediately enters the operation mode. In this case, the module is connected to the CAN bus after it has monitored 11 consecutive recessive-level bits. For details, refer to the processing in Figure 21-54.

**Caution** This function is not defined by the CAN protocol ISO 11898. When using this function, thoroughly evaluate its effect on the network system.

**Remark** n = 0, 1



**(6) Initializing CAN module error counter register (CnERC) in initialization mode**

If it is necessary to initialize the CnERC and CnINFO registers for debugging or evaluating a program, they can be initialized to the default value by setting the CnCTRL.CCERC bit in the initialization mode. When initialization has been completed, the CCERC bit is automatically cleared to 0.

- Cautions**
1. This function is enabled only in the initialization mode. Even if the CCERC bit is set to 1 in a CAN operation mode, the CnERC and CnINFO registers are not initialized.
  2. The CCERC bit can be set at the same time as the request to enter a CAN operation mode.

**Remark** n = 0, 1

21.3.7 Baud rate control function

(1) Prescaler

The CAN controller has a prescaler that divides the clock ( $f_{CAN}$ ) supplied to CAN. This prescaler generates a CAN protocol layer base clock ( $f_{TQ}$ ) that is the CAN module system clock ( $f_{CANMOD}$ ) divided by 1 to 256 (see 21.6 (12) CANn module bit rate prescaler register (CnBRP)).

(2) Data bit time (8 to 25 time quanta)

One data bit time is defined as shown in Figure 21-18.

$$1 \text{ Time Quanta} = 1/f_{TQ}$$

The CAN controller sets the data bit time by replacing it with the bit timing parameters such as time segment 1, time segment 2, and reSynchronization Jump Width (SJW), as shown in Figure 21-18. Time segment 1 is equivalent to the total of the propagation (prop) segment and phase segment 1 that are defined by the CAN protocol specification. Time segment 2 is equivalent to phase segment 2.

Figure 21-18. Segment Setting

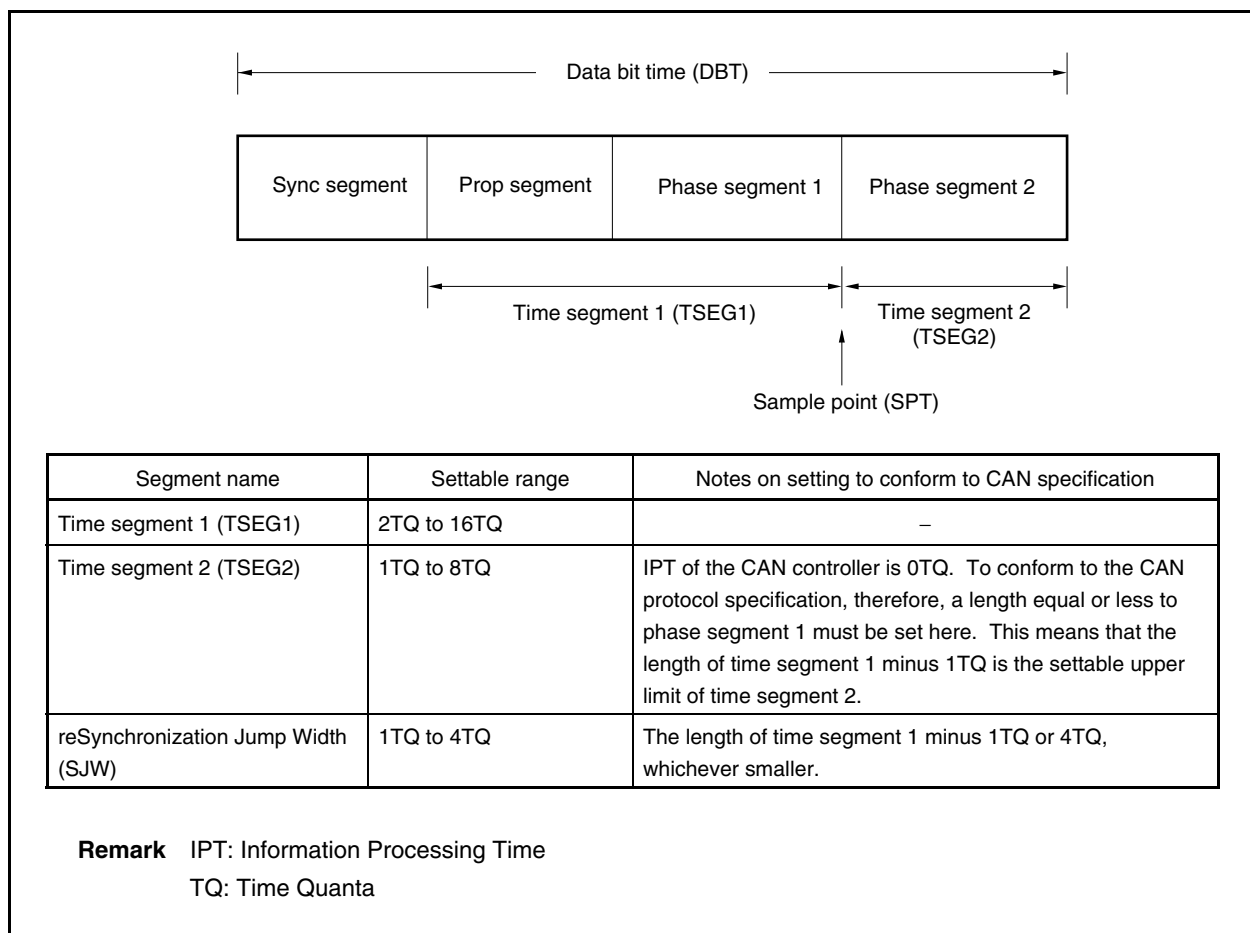

**Remark** The CAN protocol specification defines the segments constituting the data bit time as shown in Figure 21-19.

**Figure 21-19. Configuration of Data Bit Time Defined by CAN Specification**

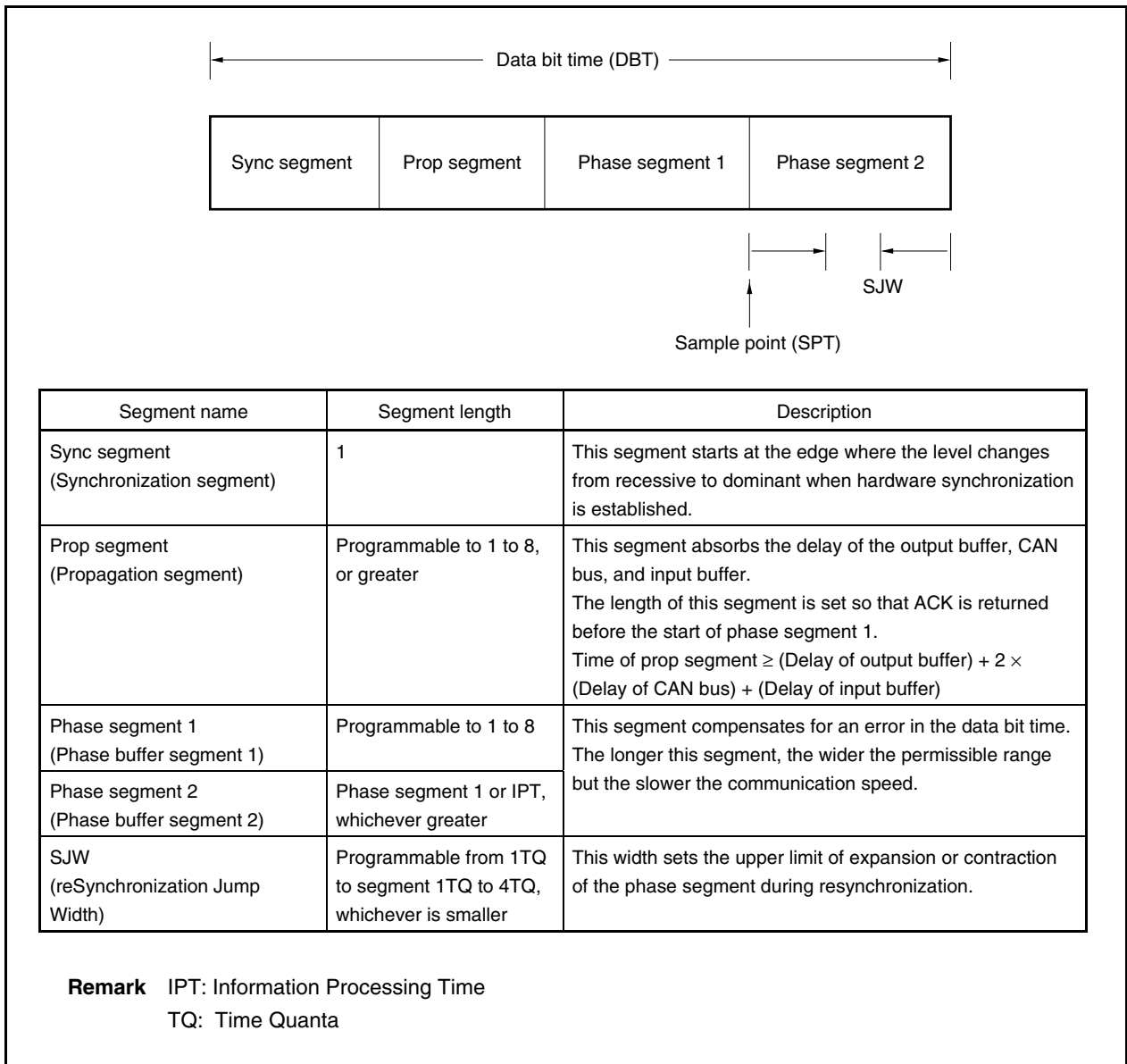

**(3) Synchronizing data bit**

- The receiving node establishes synchronization by a level change on the bus because it does not have a sync signal.
- The transmitting node transmits data in synchronization with the bit timing of the transmitting node.

**(a) Hardware synchronization**

This synchronization is established when the receiving node detects the start of frame in the interframe space.

- When a falling edge is detected on the bus, that TQ means the sync segment and the next segment is the prop segment. In this case, synchronization is established regardless of SJW.

**Figure 21-20. Hardware Synchronization Due to Dominant Level Detection During Bus Idle**

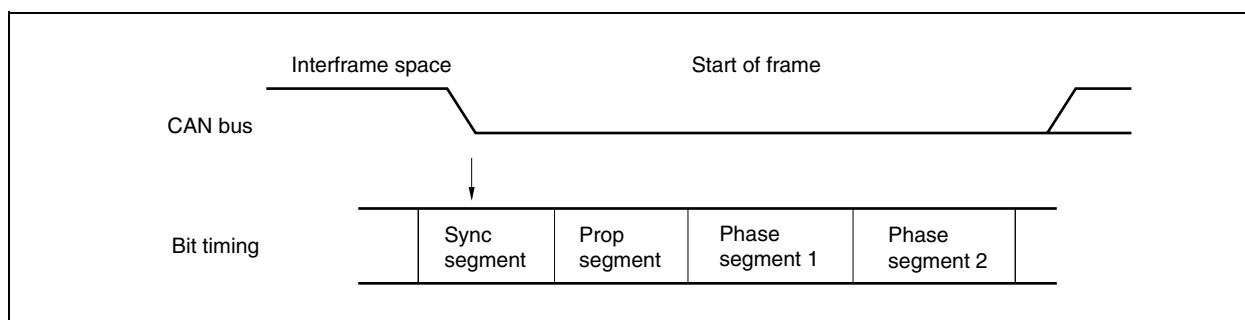

**(b) Resynchronization**

Synchronization is established again if a level change is detected on the bus during reception (only if a recessive level was sampled previously).

- The phase error of the edge is given by the relative position of the detected edge and sync segment.
  - <Sign of phase error>
  - 0: If the edge is within the sync segment
  - Positive: If the edge is before the sample point (phase error)
  - Negative: If the edge is after the sample point (phase error)
  - If phase error is positive: Phase segment 1 is longer by specified SJW.
  - If phase error is negative: Phase segment 2 is shorter by specified SJW.
- The sample point of the data of the receiving node moves relatively due to the “discrepancy” in the baud rate between the transmitting node and receiving node.

**Figure 21-21. Resynchronization**

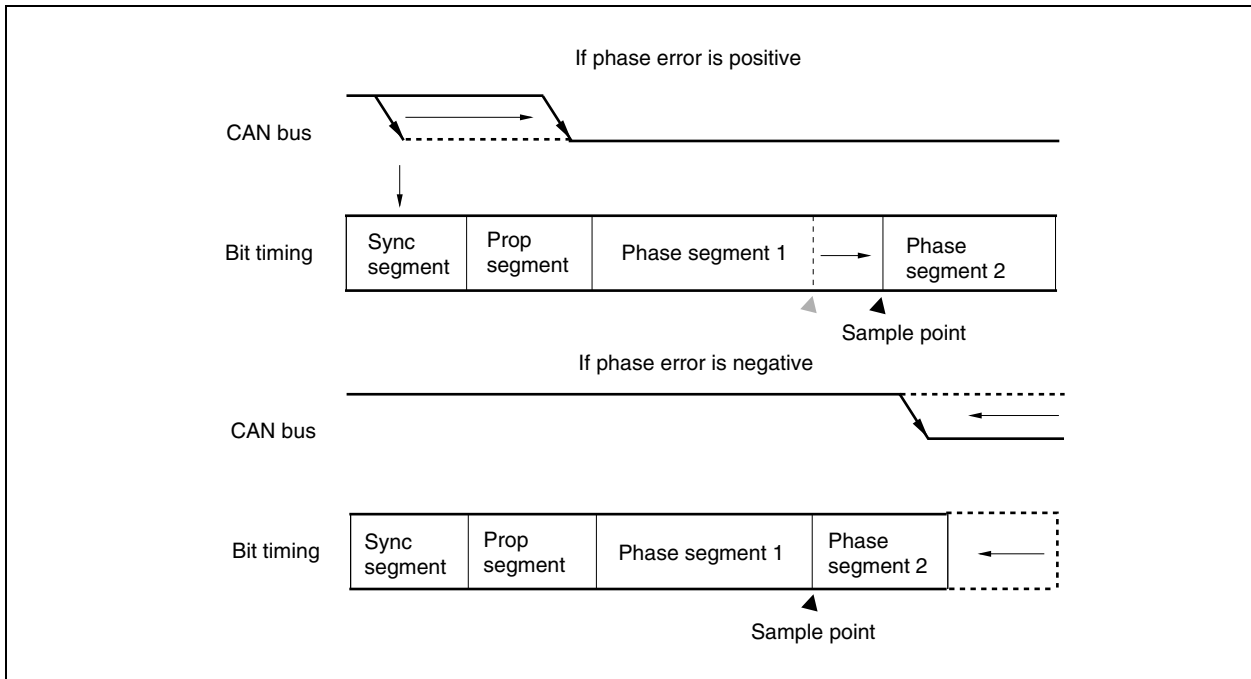

## 21.4 Connection with Target System

The microcontroller with on-chip CAN controller has to be connected to the CAN bus using an external transceiver.

**Figure 21-22. Connection to CAN Bus**

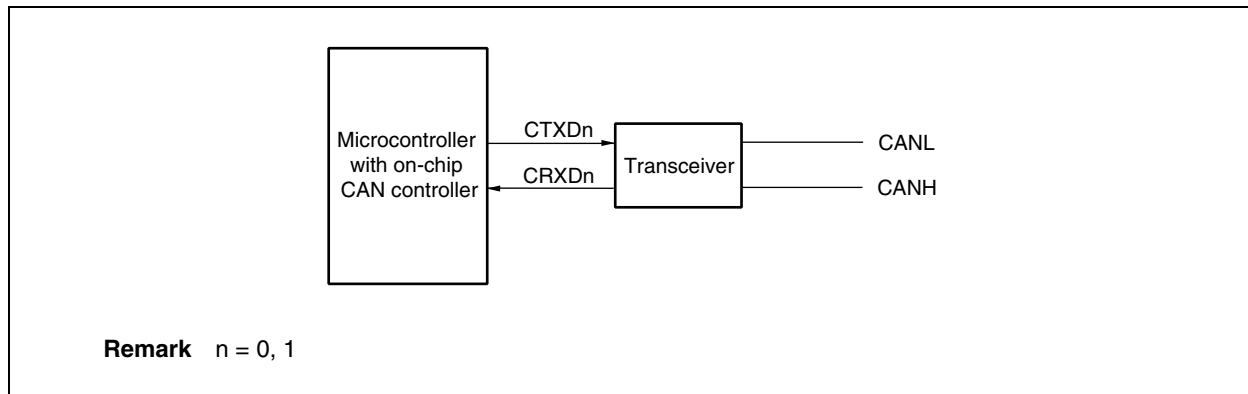

## 21.5 Internal Registers of CAN Controller

### 21.5.1 CAN controller configuration

**Table 21-15. List of CAN Controller Registers**

Item	Register Name
CAN global registers	CANn global control register (CnGMCTRL)
	CANn global clock selection register (CnGMCS)
	CANn global automatic block transmission control register (CnGMABT)
	CANn global automatic block transmission delay setting register (CnGMABTD)
CAN module registers	CANn module mask 1 register (CnMASK1L, CnMASK1H)
	CANn module mask 2 register (CnMASK2L, CnMASK2H)
	CANn module mask 3 register (CnMASK3L, CnMASK3H)
	CANn module mask 4 registers (CnMASK4L, CnMASK4H)
	CANn module control register (CnCTRL)
	CANn module last error information register (CnLEC)
	CANn module information register (CnINFO)
	CANn module error counter register (CnERC)
	CANn module interrupt enable register (CnIE)
	CANn module interrupt status register (CnINTS)
	CANn module bit rate prescaler register (CnBRP)
	CANn module bit rate register (CnBTR)
	CANn module last in-pointer register (CnLIPT)
	CANn module receive history list register (CnRGPT)
	CANn module last out-pointer register (CnLOPT)
	CANn module transmit history list register (CnTGPT)
CANn module time stamp register (CnTS)	
Message buffer registers	CANn message data byte 01 register m (CnMDATA01m)
	CANn message data byte 0 register m (CnMDATA0m)
	CANn message data byte 1 register m (CnMDATA1m)
	CANn message data byte 23 register m (CnMDATA23m)
	CANn message data byte 2 register m (CnMDATA2m)
	CANn message data byte 3 register m (CnMDATA3m)
	CANn message data byte 45 register m (CnMDATA45m)
	CANn message data byte 4 register m (CnMDATA4m)
	CANn message data byte 5 register m (CnMDATA5m)
	CANn message data byte 67 register m (CnMDATA67m)
	CANn message data byte 6 register m (CnMDATA6m)
	CANn message data byte 7 register m (CnMDATA7m)
	CANn message data length register m (CnMDLCm)
	CANn message configuration register m (CnMCONFm)
	CANn message ID register m (CnMIDLm, CnMIDHm)
	CANn message control register m (CnMCTRLm)

- Remarks**
- The CAN global register is defined as CnGM <register function>.  
The CAN module register is defined as Cn <register function>.  
The message buffer register is defined as CnM <register function>.
  - n = 0, 1  
m = 00 to 31

## 21.5.2 Register access type

Table 21-16. Register Access Types (1/34)

Address	Register Name	Symbol	R/W	Bit Manipulation Units			After Reset
				1 Bit	8 Bits	16 Bits	
03FEC000H	CAN0 global control register	C0GMCTRL	R/W			√	0000H
03FEC002H	CAN0 global clock selection register	C0GMCS			√		0FH
03FEC006H	CAN0 global automatic block transmission register	C0GMABT				√	0000H
03FEC008H	CAN0 global automatic block transmission delay register	C0GMABTD			√		00H
03FEC040H	CAN0 module mask 1 register	C0MASK1L				√	Undefined
03FEC042H		C0MASK1H				√	Undefined
03FEC044H	CAN0 module mask 2 register	C0MASK2L				√	Undefined
03FEC046H		C0MASK2H				√	Undefined
03FEC048H	CAN0 module mask 3 register	C0MASK3L				√	Undefined
03FEC04AH		C0MASK3H				√	Undefined
03FEC04CH	CAN0 module mask 4 register	C0MASK4L				√	Undefined
03FEC04EH		C0MASK4H				√	Undefined
03FEC050H	CAN0 module control register	C0CTRL				√	0000H
03FEC052H	CAN0 module last error code register	C0LEC			√		00H
03FEC053H	CAN0 module information register	C0INFO	R		√	00H	
03FEC054H	CAN0 module error counter register	C0ERC			√	0000H	
03FEC056H	CAN0 module interrupt enable register	C0IE	R/W			√	0000H
03FEC058H	CAN0 module interrupt status register	C0INTS				√	0000H
03FEC05AH	CAN0 module bit-rate prescaler register	C0BRP			√		FFH
03FEC05CH	CAN0 module bit-rate register	C0BTR				√	370FH
03FEC05EH	CAN0 module last in-pointer register	C0LIPT	R		√	Undefined	
03FEC060H	CAN0 module receive history list register	C0RGPT	R/W			√	xx02H
03FEC062H	CAN0 module last out-pointer register	C0LOPT	R		√	Undefined	
03FEC064H	CAN0 module transmit history list register	C0TGPT	R/W			√	xx02H
03FEC066H	CAN0 module time stamp register	C0TS				√	0000H



Table 21-16. Register Access Types (2/34)

Address	Register Name	Symbol	R/W	Bit Manipulation Units			After Reset
				1 Bit	8 Bits	16 Bits	
03FEC100H	CAN0 message data byte 01 register 00	C0MDATA0100	R/W			√	Undefined
03FEC100H	CAN0 message data byte 0 register 00	C0MDATA000			√		Undefined
03FEC101H	CAN0 message data byte 1 register 00	C0MDATA100			√		Undefined
03FEC102H	CAN0 message data byte 23 register 00	C0MDATA2300				√	Undefined
03FEC102H	CAN0 message data byte 2 register 00	C0MDATA200			√		Undefined
03FEC103H	CAN0 message data byte 3 register 00	C0MDATA300			√		Undefined
03FEC104H	CAN0 message data byte 45 register 00	C0MDATA4500				√	Undefined
03FEC104H	CAN0 message data byte 4 register 00	C0MDATA400			√		Undefined
03FEC105H	CAN0 message data byte 5 register 00	C0MDATA500			√		Undefined
03FEC106H	CAN0 message data byte 67 register 00	C0MDATA6700				√	Undefined
03FEC106H	CAN0 message data byte 6 register 00	C0MDATA600			√		Undefined
03FEC107H	CAN0 message data byte 7 register 00	C0MDATA700			√		Undefined
03FEC108H	CAN0 message data length register 00	C0MDLC00			√		0000xxxxB
03FEC109H	CAN0 message configuration register 00	C0MCONF00			√		Undefined
03FEC10AH	CAN0 message identifier register 00	C0MIDL00				√	Undefined
03FEC10CH		C0MIDH00				√	Undefined
03FEC10EH	CAN0 message control register 00	C0MCTRL00				√	00x00000 000xx000B
03FEC120H	CAN0 message data byte 01 register 01	C0MDATA0101				√	Undefined
03FEC120H	CAN0 message data byte 0 register 01	C0MDATA001			√		Undefined
03FEC121H	CAN0 message data byte 1 register 01	C0MDATA101			√		Undefined
03FEC122H	CAN0 message data byte 23 register 01	C0MDATA2301				√	Undefined
03FEC122H	CAN0 message data byte 2 register 01	C0MDATA201			√		Undefined
03FEC123H	CAN0 message data byte 3 register 01	C0MDATA301			√		Undefined
03FEC124H	CAN0 message data byte 45 register 01	C0MDATA4501				√	Undefined
03FEC124H	CAN0 message data byte 4 register 01	C0MDATA401			√		Undefined
03FEC125H	CAN0 message data byte 5 register 01	C0MDATA501			√		Undefined
03FEC126H	CAN0 message data byte 67 register 01	C0MDATA6701				√	Undefined
03FEC126H	CAN0 message data byte 6 register 01	C0MDATA601			√		Undefined
03FEC127H	CAN0 message data byte 7 register 01	C0MDATA701		√		Undefined	
03FEC128H	CAN0 message data length register 01	C0MDLC01		√		0000xxxxB	
03FEC129H	CAN0 message configuration register 01	C0MCONF01		√		Undefined	
03FEC12AH	CAN0 message identifier register 01	C0MIDL01			√	Undefined	
03FEC12CH		C0MIDH01			√	Undefined	
03FEC12EH	CAN0 message control register 01	C0MCTRL01			√	00x00000 000xx000B	

Table 21-16. Register Access Types (3/34)

Address	Register Name	Symbol	R/W	Bit Manipulation Units			After Reset
				1 Bit	8 Bits	16 Bits	
03FEC140H	CAN0 message data byte 01 register 02	COMDATA0102	R/W			√	Undefined
03FEC140H	CAN0 message data byte 0 register 02	COMDATA002			√		Undefined
03FEC141H	CAN0 message data byte 1 register 02	COMDATA102			√		Undefined
03FEC142H	CAN0 message data byte 23 register 02	COMDATA2302				√	Undefined
03FEC142H	CAN0 message data byte 2 register 02	COMDATA202			√		Undefined
03FEC143H	CAN0 message data byte 3 register 02	COMDATA302			√		Undefined
03FEC144H	CAN0 message data byte 45 register 02	COMDATA4502				√	Undefined
03FEC144H	CAN0 message data byte 4 register 02	COMDATA402			√		Undefined
03FEC145H	CAN0 message data byte 5 register 02	COMDATA502			√		Undefined
03FEC146H	CAN0 message data byte 67 register 02	COMDATA6702				√	Undefined
03FEC146H	CAN0 message data byte 6 register 02	COMDATA602			√		Undefined
03FEC147H	CAN0 message data byte 7 register 02	COMDATA702			√		Undefined
03FEC148H	CAN0 message data length register 02	COMDLC02			√		0000xxxxB
03FEC149H	CAN0 message configuration register 02	COMCONF02			√		Undefined
03FEC14AH	CAN0 message identifier register 02	COMIDL02				√	Undefined
03FEC14CH		COMIDH02				√	Undefined
03FEC14EH	CAN0 message control register 02	COMCTRL02				√	00x00000 000xx000B
03FEC160H	CAN0 message data byte 01 register 03	COMDATA0103				√	Undefined
03FEC160H	CAN0 message data byte 0 register 03	COMDATA003			√		Undefined
03FEC161H	CAN0 message data byte 1 register 03	COMDATA103			√		Undefined
03FEC162H	CAN0 message data byte 23 register 03	COMDATA2303				√	Undefined
03FEC162H	CAN0 message data byte 2 register 03	COMDATA203			√		Undefined
03FEC163H	CAN0 message data byte 3 register 03	COMDATA303			√		Undefined
03FEC164H	CAN0 message data byte 45 register 03	COMDATA4503				√	Undefined
03FEC164H	CAN0 message data byte 4 register 03	COMDATA403			√		Undefined
03FEC165H	CAN0 message data byte 5 register 03	COMDATA503			√		Undefined
03FEC166H	CAN0 message data byte 67 register 03	COMDATA6703				√	Undefined
03FEC166H	CAN0 message data byte 6 register 03	COMDATA603			√		Undefined
03FEC167H	CAN0 message data byte 7 register 03	COMDATA703			√		Undefined
03FEC168H	CAN0 message data length register 03	COMDLC03			√		0000xxxxB
03FEC169H	CAN0 message configuration register 03	COMCONF03			√		Undefined
03FEC16AH	CAN0 message identifier register 03	COMIDL03				√	Undefined
03FEC16CH		COMIDH03				√	Undefined
03FEC16EH	CAN0 message control register 03	COMCTRL03				√	00x00000 000xx000B

Table 21-16. Register Access Types (4/34)

Address	Register Name	Symbol	R/W	Bit Manipulation Units			After Reset
				1 Bit	8 Bits	16 Bits	
03FEC180H	CAN0 message data byte 01 register 04	C0MDATA0104	R/W			√	Undefined
03FEC180H	CAN0 message data byte 0 register 04	C0MDATA004			√		Undefined
03FEC181H	CAN0 message data byte 1 register 04	C0MDATA104			√		Undefined
03FEC182H	CAN0 message data byte 23 register 04	C0MDATA2304				√	Undefined
03FEC182H	CAN0 message data byte 2 register 04	C0MDATA204			√		Undefined
03FEC183H	CAN0 message data byte 3 register 04	C0MDATA304			√		Undefined
03FEC184H	CAN0 message data byte 45 register 04	C0MDATA4504				√	Undefined
03FEC184H	CAN0 message data byte 4 register 04	C0MDATA404			√		Undefined
03FEC185H	CAN0 message data byte 5 register 04	C0MDATA504			√		Undefined
03FEC186H	CAN0 message data byte 67 register 04	C0MDATA6704				√	Undefined
03FEC186H	CAN0 message data byte 6 register 04	C0MDATA604			√		Undefined
03FEC187H	CAN0 message data byte 7 register 04	C0MDATA704			√		Undefined
03FEC188H	CAN0 message data length register 04	C0MDLC04			√		0000xxxxB
03FEC189H	CAN0 message configuration register 04	C0MCONF04			√		Undefined
03FEC18AH	CAN0 message identifier register 04	C0MIDL04				√	Undefined
03FEC18CH		C0MIDH04				√	Undefined
03FEC18EH	CAN0 message control register 04	C0MCTRL04				√	00x00000 000xx000B
03FEC1A0H	CAN0 message data byte 01 register 05	C0MDATA0105				√	Undefined
03FEC1A0H	CAN0 message data byte 0 register 05	C0MDATA005			√		Undefined
03FEC1A1H	CAN0 message data byte 1 register 05	C0MDATA105			√		Undefined
03FEC1A2H	CAN0 message data byte 23 register 05	C0MDATA2305				√	Undefined
03FEC1A2H	CAN0 message data byte 2 register 05	C0MDATA205			√		Undefined
03FEC1A3H	CAN0 message data byte 3 register 05	C0MDATA305			√		Undefined
03FEC1A4H	CAN0 message data byte 45 register 05	C0MDATA4505				√	Undefined
03FEC1A4H	CAN0 message data byte 4 register 05	C0MDATA405			√		Undefined
03FEC1A5H	CAN0 message data byte 5 register 05	C0MDATA505			√		Undefined
03FEC1A6H	CAN0 message data byte 67 register 05	C0MDATA6705				√	Undefined
03FEC1A6H	CAN0 message data byte 6 register 05	C0MDATA605			√		Undefined
03FEC1A7H	CAN0 message data byte 7 register 05	C0MDATA705			√		Undefined
03FEC1A8H	CAN0 message data length register 05	C0MDLC05			√		0000xxxxB
03FEC1A9H	CAN0 message configuration register 05	C0MCONF05		√		Undefined	
03FEC1AAH	CAN0 message identifier register 05	C0MIDL05			√	Undefined	
03FEC1ACH		C0MIDH05			√	Undefined	
03FEC1AEH	CAN0 message control register 05	C0MCTRL05			√	00x00000 000xx000B	

Table 21-16. Register Access Types (5/34)

Address	Register Name	Symbol	R/W	Bit Manipulation Units			After Reset
				1 Bit	8 Bits	16 Bits	
03FEC1C0H	CAN0 message data byte 01 register 06	COMDATA0106	R/W			√	Undefined
03FEC1C0H	CAN0 message data byte 0 register 06	COMDATA006			√		Undefined
03FEC1C1H	CAN0 message data byte 1 register 06	COMDATA106			√		Undefined
03FEC1C2H	CAN0 message data byte 23 register 06	COMDATA2306				√	Undefined
03FEC1C2H	CAN0 message data byte 2 register 06	COMDATA206			√		Undefined
03FEC1C3H	CAN0 message data byte 3 register 06	COMDATA306			√		Undefined
03FEC1C4H	CAN0 message data byte 45 register 06	COMDATA4506				√	Undefined
03FEC1C4H	CAN0 message data byte 4 register 06	COMDATA406			√		Undefined
03FEC1C5H	CAN0 message data byte 5 register 06	COMDATA506			√		Undefined
03FEC1C6H	CAN0 message data byte 67 register 06	COMDATA6706				√	Undefined
03FEC1C6H	CAN0 message data byte 6 register 06	COMDATA606			√		Undefined
03FEC1C7H	CAN0 message data byte 7 register 06	COMDATA706			√		Undefined
03FEC1C8H	CAN0 message data length register 06	COMDLC06			√		0000xxxxB
03FEC1C9H	CAN0 message configuration register 06	COMCONF06			√		Undefined
03FEC1CAH	CAN0 message identifier register 06	COMIDL06				√	Undefined
03FEC1CCH		COMIDH06				√	Undefined
03FEC1CEH	CAN0 message control register 06	COMCTRL06				√	00x00000 000xx000B
03FEC1E0H	CAN0 message data byte 01 register 07	COMDATA0107				√	Undefined
03FEC1E0H	CAN0 message data byte 0 register 07	COMDATA007			√		Undefined
03FEC1E1H	CAN0 message data byte 1 register 07	COMDATA107			√		Undefined
03FEC1E2H	CAN0 message data byte 23 register 07	COMDATA2307				√	Undefined
03FEC1E2H	CAN0 message data byte 2 register 07	COMDATA207			√		Undefined
03FEC1E3H	CAN0 message data byte 3 register 07	COMDATA307			√		Undefined
03FEC1E4H	CAN0 message data byte 45 register 07	COMDATA4507				√	Undefined
03FEC1E4H	CAN0 message data byte 4 register 07	COMDATA407			√		Undefined
03FEC1E5H	CAN0 message data byte 5 register 07	COMDATA507			√		Undefined
03FEC1E6H	CAN0 message data byte 67 register 07	COMDATA6707				√	Undefined
03FEC1E6H	CAN0 message data byte 6 register 07	COMDATA607			√		Undefined
03FEC1E7H	CAN0 message data byte 7 register 07	COMDATA707			√		Undefined
03FEC1E8H	CAN0 message data length register 07	COMDLC07			√		0000xxxxB
03FEC1E9H	CAN0 message configuration register 07	COMCONF07			√		Undefined
03FEC1EAH	CAN0 message identifier register 07	COMIDL07				√	Undefined
03FEC1ECH		COMIDH07				√	Undefined
03FEC1EEH	CAN0 message control register 07	COMCTRL07			√	00x00000 000xx000B	

Table 21-16. Register Access Types (6/34)

Address	Register Name	Symbol	R/W	Bit Manipulation Units			After Reset
				1 Bit	8 Bits	16 Bits	
03FEC200H	CAN0 message data byte 01 register 08	C0MDATA0108	R/W			√	Undefined
03FEC200H	CAN0 message data byte 0 register 08	C0MDATA008			√		Undefined
03FEC201H	CAN0 message data byte 1 register 08	C0MDATA108			√		Undefined
03FEC202H	CAN0 message data byte 23 register 08	C0MDATA2308				√	Undefined
03FEC202H	CAN0 message data byte 2 register 08	C0MDATA208			√		Undefined
03FEC203H	CAN0 message data byte 3 register 08	C0MDATA308			√		Undefined
03FEC204H	CAN0 message data byte 45 register 08	C0MDATA4508				√	Undefined
03FEC204H	CAN0 message data byte 4 register 08	C0MDATA408			√		Undefined
03FEC205H	CAN0 message data byte 5 register 08	C0MDATA508			√		Undefined
03FEC206H	CAN0 message data byte 67 register 08	C0MDATA6708				√	Undefined
03FEC206H	CAN0 message data byte 6 register 08	C0MDATA608			√		Undefined
03FEC207H	CAN0 message data byte 7 register 08	C0MDATA708			√		Undefined
03FEC208H	CAN0 message data length register 08	C0MDLC08			√		0000xxxxB
03FEC209H	CAN0 message configuration register 08	C0MCONF08			√		Undefined
03FEC20AH	CAN0 message identifier register 08	C0MIDL08				√	Undefined
03FEC20CH		C0MIDH08				√	Undefined
03FEC20EH	CAN0 message control register 08	C0MCTRL08				√	00x00000 000xx000B
03FEC220H	CAN0 message data byte 01 register 09	C0MDATA0109				√	Undefined
03FEC220H	CAN0 message data byte 0 register 09	C0MDATA009			√		Undefined
03FEC221H	CAN0 message data byte 1 register 09	C0MDATA109			√		Undefined
03FEC222H	CAN0 message data byte 23 register 09	C0MDATA2309				√	Undefined
03FEC222H	CAN0 message data byte 2 register 09	C0MDATA209			√		Undefined
03FEC223H	CAN0 message data byte 3 register 09	C0MDATA309			√		Undefined
03FEC224H	CAN0 message data byte 45 register 09	C0MDATA4509				√	Undefined
03FEC224H	CAN0 message data byte 4 register 09	C0MDATA409			√		Undefined
03FEC225H	CAN0 message data byte 5 register 09	C0MDATA509			√		Undefined
03FEC226H	CAN0 message data byte 67 register 09	C0MDATA6709				√	Undefined
03FEC226H	CAN0 message data byte 6 register 09	C0MDATA609			√		Undefined
03FEC227H	CAN0 message data byte 7 register 09	C0MDATA709		√		Undefined	
03FEC228H	CAN0 message data length register 09	C0MDLC09		√		0000xxxxB	
03FEC229H	CAN0 message configuration register 09	C0MCONF09		√		Undefined	
03FEC22AH	CAN0 message identifier register 09	C0MIDL09			√	Undefined	
03FEC22CH		C0MIDH09			√	Undefined	
03FEC22EH	CAN0 message control register 09	C0MCTRL09			√	00x00000 000xx000B	

Table 21-16. Register Access Types (7/34)

Address	Register Name	Symbol	R/W	Bit Manipulation Units			After Reset
				1 Bit	8 Bits	16 Bits	
03FEC240H	CAN0 message data byte 01 register 10	COMDATA0110	R/W			√	Undefined
03FEC240H	CAN0 message data byte 0 register 10	COMDATA010			√		Undefined
03FEC241H	CAN0 message data byte 1 register 10	COMDATA110			√		Undefined
03FEC242H	CAN0 message data byte 23 register 10	COMDATA2310				√	Undefined
03FEC242H	CAN0 message data byte 2 register 10	COMDATA210			√		Undefined
03FEC243H	CAN0 message data byte 3 register 10	COMDATA310			√		Undefined
03FEC244H	CAN0 message data byte 45 register 10	COMDATA4510				√	Undefined
03FEC244H	CAN0 message data byte 4 register 10	COMDATA410			√		Undefined
03FEC245H	CAN0 message data byte 5 register 10	COMDATA510			√		Undefined
03FEC246H	CAN0 message data byte 67 register 10	COMDATA6710				√	Undefined
03FEC246H	CAN0 message data byte 6 register 10	COMDATA610			√		Undefined
03FEC247H	CAN0 message data byte 7 register 10	COMDATA710			√		Undefined
03FEC248H	CAN0 message data length register 10	COMDLC10			√		0000xxxxB
03FEC249H	CAN0 message configuration register 10	COMCONF10			√		Undefined
03FEC24AH	CAN0 message identifier register 10	COMIDL10				√	Undefined
03FEC24CH		COMIDH10				√	Undefined
03FEC24EH	CAN0 message control register 10	COMCTRL10				√	00x00000 000xx000B
03FEC260H	CAN0 message data byte 01 register 11	COMDATA0111				√	Undefined
03FEC260H	CAN0 message data byte 0 register 11	COMDATA011			√		Undefined
03FEC261H	CAN0 message data byte 1 register 11	COMDATA111			√		Undefined
03FEC262H	CAN0 message data byte 23 register 11	COMDATA2311				√	Undefined
03FEC262H	CAN0 message data byte 2 register 11	COMDATA211			√		Undefined
03FEC263H	CAN0 message data byte 3 register 11	COMDATA311			√		Undefined
03FEC264H	CAN0 message data byte 45 register 11	COMDATA4511				√	Undefined
03FEC264H	CAN0 message data byte 4 register 11	COMDATA411			√		Undefined
03FEC265H	CAN0 message data byte 5 register 11	COMDATA511			√		Undefined
03FEC266H	CAN0 message data byte 67 register 11	COMDATA6711				√	Undefined
03FEC266H	CAN0 message data byte 6 register 11	COMDATA611			√		Undefined
03FEC267H	CAN0 message data byte 7 register 11	COMDATA711			√		Undefined
03FEC268H	CAN0 message data length register 11	COMDLC11			√		0000xxxxB
03FEC269H	CAN0 message configuration register 11	COMCONF11			√		Undefined
03FEC26AH	CAN0 message identifier register 11	COMIDL11				√	Undefined
03FEC26CH		COMIDH11				√	Undefined
03FEC26EH	CAN0 message control register 11	COMCTRL11			√	00x00000 000xx000B	

Table 21-16. Register Access Types (8/34)

Address	Register Name	Symbol	R/W	Bit Manipulation Units			After Reset
				1 Bit	8 Bits	16 Bits	
03FEC280H	CAN0 message data byte 01 register 12	C0MDATA0112	R/W			√	Undefined
03FEC280H	CAN0 message data byte 0 register 12	C0MDATA012			√		Undefined
03FEC281H	CAN0 message data byte 1 register 12	C0MDATA112			√		Undefined
03FEC282H	CAN0 message data byte 23 register 12	C0MDATA2312				√	Undefined
03FEC282H	CAN0 message data byte 2 register 12	C0MDATA212			√		Undefined
03FEC283H	CAN0 message data byte 3 register 12	C0MDATA312			√		Undefined
03FEC284H	CAN0 message data byte 45 register 12	C0MDATA4512				√	Undefined
03FEC284H	CAN0 message data byte 4 register 12	C0MDATA412			√		Undefined
03FEC285H	CAN0 message data byte 5 register 12	C0MDATA512			√		Undefined
03FEC286H	CAN0 message data byte 67 register 12	C0MDATA6712				√	Undefined
03FEC286H	CAN0 message data byte 6 register 12	C0MDATA612			√		Undefined
03FEC287H	CAN0 message data byte 7 register 12	C0MDATA712			√		Undefined
03FEC288H	CAN0 message data length register 12	C0MDLC12			√		0000xxxxB
03FEC289H	CAN0 message configuration register 12	C0MCONF12			√		Undefined
03FEC28AH	CAN0 message identifier register 12	C0MIDL12				√	Undefined
03FEC28CH		C0MIDH12				√	Undefined
03FEC28EH	CAN0 message control register 12	C0MCTRL12				√	00x00000 000xx000B
03FEC2A0H	CAN0 message data byte 01 register 13	C0MDATA0113				√	Undefined
03FEC2A0H	CAN0 message data byte 0 register 13	C0MDATA013			√		Undefined
03FEC2A1H	CAN0 message data byte 1 register 13	C0MDATA113			√		Undefined
03FEC2A2H	CAN0 message data byte 23 register 13	C0MDATA2313				√	Undefined
03FEC2A2H	CAN0 message data byte 2 register 13	C0MDATA213			√		Undefined
03FEC2A3H	CAN0 message data byte 3 register 13	C0MDATA313			√		Undefined
03FEC2A4H	CAN0 message data byte 45 register 13	C0MDATA4513				√	Undefined
03FEC2A4H	CAN0 message data byte 4 register 13	C0MDATA413		√		Undefined	
03FEC2A5H	CAN0 message data byte 5 register 13	C0MDATA513		√		Undefined	
03FEC2A6H	CAN0 message data byte 67 register 13	C0MDATA6713			√	Undefined	
03FEC2A6H	CAN0 message data byte 6 register 13	C0MDATA613		√		Undefined	
03FEC2A7H	CAN0 message data byte 7 register 13	C0MDATA713		√		Undefined	
03FEC2A8H	CAN0 message data length register 13	C0MDLC13		√		0000xxxxB	
03FEC2A9H	CAN0 message configuration register 13	C0MCONF13		√		Undefined	
03FEC2AAH	CAN0 message identifier register 13	C0MIDL13			√	Undefined	
03FEC2ACH		C0MIDH13			√	Undefined	
03FEC2AEH	CAN0 message control register 13	C0MCTRL13			√	00x00000 000xx000B	

Table 21-16. Register Access Types (9/34)

Address	Register Name	Symbol	R/W	Bit Manipulation Units			After Reset
				1 Bit	8 Bits	16 Bits	
03FEC2C0H	CAN0 message data byte 01 register 14	COMDATA0114	R/W			√	Undefined
03FEC2C0H	CAN0 message data byte 0 register 14	COMDATA014			√		Undefined
03FEC2C1H	CAN0 message data byte 1 register 14	COMDATA114			√		Undefined
03FEC2C2H	CAN0 message data byte 23 register 14	COMDATA2314				√	Undefined
03FEC2C2H	CAN0 message data byte 2 register 14	COMDATA214			√		Undefined
03FEC2C3H	CAN0 message data byte 3 register 14	COMDATA314			√		Undefined
03FEC2C4H	CAN0 message data byte 45 register 14	COMDATA4514				√	Undefined
03FEC2C4H	CAN0 message data byte 4 register 14	COMDATA414			√		Undefined
03FEC2C5H	CAN0 message data byte 5 register 14	COMDATA514			√		Undefined
03FEC2C6H	CAN0 message data byte 67 register 14	COMDATA6714				√	Undefined
03FEC2C6H	CAN0 message data byte 6 register 14	COMDATA614			√		Undefined
03FEC2C7H	CAN0 message data byte 7 register 14	COMDATA714			√		Undefined
03FEC2C8H	CAN0 message data length register 14	COMDLC14			√		0000xxxxB
03FEC2C9H	CAN0 message configuration register 14	COMCONF14			√		Undefined
03FEC2CAH	CAN0 message identifier register 14	COMIDL14				√	Undefined
03FEC2CCH		COMIDH14				√	Undefined
03FEC2CEH	CAN0 message control register 14	COMCTRL14				√	00x00000 000xx000B
03FEC2E0H	CAN0 message data byte 01 register 15	COMDATA0115				√	Undefined
03FEC2E0H	CAN0 message data byte 0 register 15	COMDATA015			√		Undefined
03FEC2E1H	CAN0 message data byte 1 register 15	COMDATA115			√		Undefined
03FEC2E2H	CAN0 message data byte 23 register 15	COMDATA2315				√	Undefined
03FEC2E2H	CAN0 message data byte 2 register 15	COMDATA215			√		Undefined
03FEC2E3H	CAN0 message data byte 3 register 15	COMDATA315			√		Undefined
03FEC2E4H	CAN0 message data byte 45 register 15	COMDATA4515				√	Undefined
03FEC2E4H	CAN0 message data byte 4 register 15	COMDATA415			√		Undefined
03FEC2E5H	CAN0 message data byte 5 register 15	COMDATA515			√		Undefined
03FEC2E6H	CAN0 message data byte 67 register 15	COMDATA6715				√	Undefined
03FEC2E6H	CAN0 message data byte 6 register 15	COMDATA615		√		Undefined	
03FEC2E7H	CAN0 message data byte 7 register 15	COMDATA715		√		Undefined	
03FEC2E8H	CAN0 message data length register 15	COMDLC15		√		0000xxxxB	
03FEC2E9H	CAN0 message configuration register 15	COMCONF15		√		Undefined	
03FEC2EAH	CAN0 message identifier register 15	COMIDL15			√	Undefined	
03FEC2ECH		COMIDH15			√	Undefined	
03FEC2EEH	CAN0 message control register 15	COMCTRL15			√	00x00000 000xx000B	



Table 21-16. Register Access Types (10/34)

Address	Register Name	Symbol	R/W	Bit Manipulation Units			After Reset
				1 Bit	8 Bits	16 Bits	
03FEC300H	CAN0 message data byte 01 register 16	C0MDATA0116	R/W			√	Undefined
03FEC300H	CAN0 message data byte 0 register 16	C0MDATA016			√		Undefined
03FEC301H	CAN0 message data byte 1 register 16	C0MDATA116			√		Undefined
03FEC302H	CAN0 message data byte 23 register 16	C0MDATA2316				√	Undefined
03FEC302H	CAN0 message data byte 2 register 16	C0MDATA216			√		Undefined
03FEC303H	CAN0 message data byte 3 register 16	C0MDATA316			√		Undefined
03FEC304H	CAN0 message data byte 45 register 16	C0MDATA4516				√	Undefined
03FEC304H	CAN0 message data byte 4 register 16	C0MDATA416			√		Undefined
03FEC305H	CAN0 message data byte 5 register 16	C0MDATA516			√		Undefined
03FEC306H	CAN0 message data byte 67 register 16	C0MDATA6716				√	Undefined
03FEC306H	CAN0 message data byte 6 register 16	C0MDATA616			√		Undefined
03FEC307H	CAN0 message data byte 7 register 16	C0MDATA716			√		Undefined
03FEC308H	CAN0 message data length register 16	C0MDLC16			√		0000xxxxB
03FEC309H	CAN0 message configuration register 16	C0MCONF16			√		Undefined
03FEC30AH	CAN0 message identifier register 16	C0MIDL16				√	Undefined
03FEC30CH		C0MIDH16				√	Undefined
03FEC30EH	CAN0 message control register 16	C0MCTRL16				√	00x00000 000xx000B
03FEC320H	CAN0 message data byte 01 register 17	C0MDATA0117				√	Undefined
03FEC320H	CAN0 message data byte 0 register 17	C0MDATA017			√		Undefined
03FEC321H	CAN0 message data byte 1 register 17	C0MDATA117			√		Undefined
03FEC322H	CAN0 message data byte 23 register 17	C0MDATA2317				√	Undefined
03FEC322H	CAN0 message data byte 2 register 17	C0MDATA217			√		Undefined
03FEC323H	CAN0 message data byte 3 register 17	C0MDATA317			√		Undefined
03FEC324H	CAN0 message data byte 45 register 17	C0MDATA4517				√	Undefined
03FEC324H	CAN0 message data byte 4 register 17	C0MDATA417		√		Undefined	
03FEC325H	CAN0 message data byte 5 register 17	C0MDATA517		√		Undefined	
03FEC326H	CAN0 message data byte 67 register 17	C0MDATA6717			√	Undefined	
03FEC326H	CAN0 message data byte 6 register 17	C0MDATA617		√		Undefined	
03FEC327H	CAN0 message data byte 7 register 17	C0MDATA717		√		Undefined	
03FEC328H	CAN0 message data length register 17	C0MDLC17		√		0000xxxxB	
03FEC329H	CAN0 message configuration register 17	C0MCONF17		√		Undefined	
03FEC32AH	CAN0 message identifier register 17	C0MIDL17			√	Undefined	
03FEC32CH		C0MIDH17			√	Undefined	
03FEC32EH	CAN0 message control register 17	C0MCTRL17			√	00x00000 000xx000B	

Table 21-16. Register Access Types (11/34)

Address	Register Name	Symbol	R/W	Bit Manipulation Units			After Reset
				1 Bit	8 Bits	16 Bits	
03FEC340H	CAN0 message data byte 01 register 18	COMDATA0118	R/W			√	Undefined
03FEC340H	CAN0 message data byte 0 register 18	COMDATA018			√		Undefined
03FEC341H	CAN0 message data byte 1 register 18	COMDATA118			√		Undefined
03FEC342H	CAN0 message data byte 23 register 18	COMDATA2318				√	Undefined
03FEC342H	CAN0 message data byte 2 register 18	COMDATA218			√		Undefined
03FEC343H	CAN0 message data byte 3 register 18	COMDATA318			√		Undefined
03FEC344H	CAN0 message data byte 45 register 18	COMDATA4518				√	Undefined
03FEC344H	CAN0 message data byte 4 register 18	COMDATA418			√		Undefined
03FEC345H	CAN0 message data byte 5 register 18	COMDATA518			√		Undefined
03FEC346H	CAN0 message data byte 67 register 18	COMDATA6718				√	Undefined
03FEC346H	CAN0 message data byte 6 register 18	COMDATA618			√		Undefined
03FEC347H	CAN0 message data byte 7 register 18	COMDATA718			√		Undefined
03FEC348H	CAN0 message data length register 18	COMDLC18			√		0000xxxxB
03FEC349H	CAN0 message configuration register 18	COMCONF18			√		Undefined
03FEC34AH	CAN0 message identifier register 18	COMIDL18				√	Undefined
03FEC34CH		COMIDH18				√	Undefined
03FEC34EH	CAN0 message control register 18	COMCTRL18				√	00x00000 000xx000B
03FEC360H	CAN0 message data byte 01 register 19	COMDATA0119				√	Undefined
03FEC360H	CAN0 message data byte 0 register 19	COMDATA019			√		Undefined
03FEC361H	CAN0 message data byte 1 register 19	COMDATA119			√		Undefined
03FEC362H	CAN0 message data byte 23 register 19	COMDATA2319				√	Undefined
03FEC362H	CAN0 message data byte 2 register 19	COMDATA219			√		Undefined
03FEC363H	CAN0 message data byte 3 register 19	COMDATA319			√		Undefined
03FEC364H	CAN0 message data byte 45 register 19	COMDATA4519				√	Undefined
03FEC364H	CAN0 message data byte 4 register 19	COMDATA419			√		Undefined
03FEC365H	CAN0 message data byte 5 register 19	COMDATA519			√		Undefined
03FEC366H	CAN0 message data byte 67 register 19	COMDATA6719				√	Undefined
03FEC366H	CAN0 message data byte 6 register 19	COMDATA619			√		Undefined
03FEC367H	CAN0 message data byte 7 register 19	COMDATA719			√		Undefined
03FEC368H	CAN0 message data length register 19	COMDLC19			√		0000xxxxB
03FEC369H	CAN0 message configuration register 19	COMCONF19		√		Undefined	
03FEC36AH	CAN0 message identifier register 19	COMIDL19			√	Undefined	
03FEC36CH		COMIDH19			√	Undefined	
03FEC36EH	CAN0 message control register 19	COMCTRL19			√	00x00000 000xx000B	

Table 21-16. Register Access Types (12/34)

Address	Register Name	Symbol	R/W	Bit Manipulation Units			After Reset
				1 Bit	8 Bits	16 Bits	
03FEC380H	CAN0 message data byte 01 register 20	C0MDATA0120	R/W			√	Undefined
03FEC380H	CAN0 message data byte 0 register 20	C0MDATA020			√		Undefined
03FEC381H	CAN0 message data byte 1 register 20	C0MDATA120			√		Undefined
03FEC382H	CAN0 message data byte 23 register 20	C0MDATA2320				√	Undefined
03FEC382H	CAN0 message data byte 2 register 20	C0MDATA220			√		Undefined
03FEC383H	CAN0 message data byte 3 register 20	C0MDATA320			√		Undefined
03FEC384H	CAN0 message data byte 45 register 20	C0MDATA4520				√	Undefined
03FEC384H	CAN0 message data byte 4 register 20	C0MDATA420			√		Undefined
03FEC385H	CAN0 message data byte 5 register 20	C0MDATA520			√		Undefined
03FEC386H	CAN0 message data byte 67 register 20	C0MDATA6720				√	Undefined
03FEC386H	CAN0 message data byte 6 register 20	C0MDATA620			√		Undefined
03FEC387H	CAN0 message data byte 7 register 20	C0MDATA720			√		Undefined
03FEC388H	CAN0 message data length register 20	C0MDLC20			√		0000xxxxB
03FEC389H	CAN0 message configuration register 20	C0MCONF20			√		Undefined
03FEC38AH	CAN0 message identifier register 20	C0MIDL20				√	Undefined
03FEC38CH		C0MIDH20				√	Undefined
03FEC38EH	CAN0 message control register 20	C0MCTRL20				√	00x00000 000xx000B
03FEC3A0H	CAN0 message data byte 01 register 21	C0MDATA0121				√	Undefined
03FEC3A0H	CAN0 message data byte 0 register 21	C0MDATA021			√		Undefined
03FEC3A1H	CAN0 message data byte 1 register 21	C0MDATA121			√		Undefined
03FEC3A2H	CAN0 message data byte 23 register 21	C0MDATA2321				√	Undefined
03FEC3A2H	CAN0 message data byte 2 register 21	C0MDATA221			√		Undefined
03FEC3A3H	CAN0 message data byte 3 register 21	C0MDATA321			√		Undefined
03FEC3A4H	CAN0 message data byte 45 register 21	C0MDATA4521				√	Undefined
03FEC3A4H	CAN0 message data byte 4 register 21	C0MDATA421		√		Undefined	
03FEC3A5H	CAN0 message data byte 5 register 21	C0MDATA521		√		Undefined	
03FEC3A6H	CAN0 message data byte 67 register 21	C0MDATA6721			√	Undefined	
03FEC3A6H	CAN0 message data byte 6 register 21	C0MDATA621		√		Undefined	
03FEC3A7H	CAN0 message data byte 7 register 21	C0MDATA721		√		Undefined	
03FEC3A8H	CAN0 message data length register 21	C0MDLC21		√		0000xxxxB	
03FEC3A9H	CAN0 message configuration register 21	C0MCONF21		√		Undefined	
03FEC3AAH	CAN0 message identifier register 21	C0MIDL21			√	Undefined	
03FEC3ACH		C0MIDH21			√	Undefined	
03FEC3AEH	CAN0 message control register 21	C0MCTRL21			√	00x00000 000xx000B	

Table 21-16. Register Access Types (13/34)

Address	Register Name	Symbol	R/W	Bit Manipulation Units			After Reset
				1 Bit	8 Bits	16 Bits	
03FEC3C0H	CAN0 message data byte 01 register 22	COMDATA0122	R/W			√	Undefined
03FEC3C0H	CAN0 message data byte 0 register 22	COMDATA022			√		Undefined
03FEC3C1H	CAN0 message data byte 1 register 22	COMDATA122			√		Undefined
03FEC3C2H	CAN0 message data byte 23 register 22	COMDATA2322				√	Undefined
03FEC3C2H	CAN0 message data byte 2 register 22	COMDATA222			√		Undefined
03FEC3C3H	CAN0 message data byte 3 register 22	COMDATA322			√		Undefined
03FEC3C4H	CAN0 message data byte 45 register 22	COMDATA4522				√	Undefined
03FEC3C4H	CAN0 message data byte 4 register 22	COMDATA422			√		Undefined
03FEC3C5H	CAN0 message data byte 5 register 22	COMDATA522			√		Undefined
03FEC3C6H	CAN0 message data byte 67 register 22	COMDATA6722				√	Undefined
03FEC3C6H	CAN0 message data byte 6 register 22	COMDATA622			√		Undefined
03FEC3C7H	CAN0 message data byte 7 register 22	COMDATA722			√		Undefined
03FEC3C8H	CAN0 message data length register 22	COMDLC22			√		0000xxxxB
03FEC3C9H	CAN0 message configuration register 22	COMCONF22			√		Undefined
03FEC3CAH	CAN0 message identifier register 22	COMIDL22				√	Undefined
03FEC3CCH		COMIDH22				√	Undefined
03FEC3CEH	CAN0 message control register 22	COMCTRL22				√	00x00000 000xx000B
03FEC3E0H	CAN0 message data byte 01 register 23	COMDATA0123				√	Undefined
03FEC3E0H	CAN0 message data byte 0 register 23	COMDATA023			√		Undefined
03FEC3E1H	CAN0 message data byte 1 register 23	COMDATA123			√		Undefined
03FEC3E2H	CAN0 message data byte 23 register 23	COMDATA2323				√	Undefined
03FEC3E2H	CAN0 message data byte 2 register 23	COMDATA223			√		Undefined
03FEC3E3H	CAN0 message data byte 3 register 23	COMDATA323			√		Undefined
03FEC3E4H	CAN0 message data byte 45 register 23	COMDATA4523				√	Undefined
03FEC3E4H	CAN0 message data byte 4 register 23	COMDATA423			√		Undefined
03FEC3E5H	CAN0 message data byte 5 register 23	COMDATA523			√		Undefined
03FEC3E6H	CAN0 message data byte 67 register 23	COMDATA6723				√	Undefined
03FEC3E6H	CAN0 message data byte 6 register 23	COMDATA623			√		Undefined
03FEC3E7H	CAN0 message data byte 7 register 23	COMDATA723			√		Undefined
03FEC3E8H	CAN0 message data length register 23	COMDLC23			√		0000xxxxB
03FEC3E9H	CAN0 message configuration register 23	COMCONF23		√		Undefined	
03FEC3EAH	CAN0 message identifier register 23	COMIDL23			√	Undefined	
03FEC3ECH		COMIDH23			√	Undefined	
03FEC3EEH	CAN0 message control register 23	COMCTRL23			√	00x00000 000xx000B	

Table 21-16. Register Access Types (14/34)

Address	Register Name	Symbol	R/W	Bit Manipulation Units			After Reset
				1 Bit	8 Bits	16 Bits	
03FEC400H	CAN0 message data byte 01 register 24	C0MDATA0124	R/W			√	Undefined
03FEC400H	CAN0 message data byte 0 register 24	C0MDATA024			√		Undefined
03FEC401H	CAN0 message data byte 1 register 24	C0MDATA124			√		Undefined
03FEC402H	CAN0 message data byte 23 register 24	C0MDATA2324				√	Undefined
03FEC402H	CAN0 message data byte 2 register 24	C0MDATA224			√		Undefined
03FEC403H	CAN0 message data byte 3 register 24	C0MDATA324			√		Undefined
03FEC404H	CAN0 message data byte 45 register 24	C0MDATA4524				√	Undefined
03FEC404H	CAN0 message data byte 4 register 24	C0MDATA424			√		Undefined
03FEC405H	CAN0 message data byte 5 register 24	C0MDATA524			√		Undefined
03FEC406H	CAN0 message data byte 67 register 24	C0MDATA6724				√	Undefined
03FEC406H	CAN0 message data byte 6 register 24	C0MDATA624			√		Undefined
03FEC407H	CAN0 message data byte 7 register 24	C0MDATA724			√		Undefined
03FEC408H	CAN0 message data length register 24	C0MDLC24			√		0000xxxxB
03FEC409H	CAN0 message configuration register 24	C0MCONF24			√		Undefined
03FEC40AH	CAN0 message identifier register 24	C0MIDL24				√	Undefined
03FEC40CH		C0MIDH24				√	Undefined
03FEC40EH	CAN0 message control register 24	C0MCTRL24				√	00x00000 000xx000B
03FEC420H	CAN0 message data byte 01 register 25	C0MDATA0125				√	Undefined
03FEC420H	CAN0 message data byte 0 register 25	C0MDATA025			√		Undefined
03FEC421H	CAN0 message data byte 1 register 25	C0MDATA125			√		Undefined
03FEC422H	CAN0 message data byte 23 register 25	C0MDATA2325				√	Undefined
03FEC422H	CAN0 message data byte 2 register 25	C0MDATA225			√		Undefined
03FEC423H	CAN0 message data byte 3 register 25	C0MDATA325			√		Undefined
03FEC424H	CAN0 message data byte 45 register 25	C0MDATA4525				√	Undefined
03FEC424H	CAN0 message data byte 4 register 25	C0MDATA425		√		Undefined	
03FEC425H	CAN0 message data byte 5 register 25	C0MDATA525		√		Undefined	
03FEC426H	CAN0 message data byte 67 register 25	C0MDATA6725			√	Undefined	
03FEC426H	CAN0 message data byte 6 register 25	C0MDATA625		√		Undefined	
03FEC427H	CAN0 message data byte 7 register 25	C0MDATA725		√		Undefined	
03FEC428H	CAN0 message data length register 25	C0MDLC25		√		0000xxxxB	
03FEC429H	CAN0 message configuration register 25	C0MCONF25		√		Undefined	
03FEC42AH	CAN0 message identifier register 25	C0MIDL25			√	Undefined	
03FEC42CH		C0MIDH25			√	Undefined	
03FEC42EH	CAN0 message control register 25	C0MCTRL25			√	00x00000 000xx000B	

Table 21-16. Register Access Types (15/34)

Address	Register Name	Symbol	R/W	Bit Manipulation Units			After Reset
				1 Bit	8 Bits	16 Bits	
03FEC440H	CAN0 message data byte 01 register 26	COMDATA0126	R/W			√	Undefined
03FEC440H	CAN0 message data byte 0 register 26	COMDATA026			√		Undefined
03FEC441H	CAN0 message data byte 1 register 26	COMDATA126			√		Undefined
03FEC442H	CAN0 message data byte 23 register 26	COMDATA2326				√	Undefined
03FEC442H	CAN0 message data byte 2 register 26	COMDATA226			√		Undefined
03FEC443H	CAN0 message data byte 3 register 26	COMDATA326			√		Undefined
03FEC444H	CAN0 message data byte 45 register 26	COMDATA4526				√	Undefined
03FEC444H	CAN0 message data byte 4 register 26	COMDATA426			√		Undefined
03FEC445H	CAN0 message data byte 5 register 26	COMDATA526			√		Undefined
03FEC446H	CAN0 message data byte 67 register 26	COMDATA6726				√	Undefined
03FEC446H	CAN0 message data byte 6 register 26	COMDATA626			√		Undefined
03FEC447H	CAN0 message data byte 7 register 26	COMDATA726			√		Undefined
03FEC448H	CAN0 message data length register 26	COMDLC26			√		0000xxxxB
03FEC449H	CAN0 message configuration register 26	COMCONF26			√		Undefined
03FEC44AH	CAN0 message identifier register 26	COMIDL26				√	Undefined
03FEC44CH		COMIDH26				√	Undefined
03FEC44EH	CAN0 message control register 26	COMCTRL26				√	00x00000 000xx000B
03FEC460H	CAN0 message data byte 01 register 27	COMDATA0127				√	Undefined
03FEC460H	CAN0 message data byte 0 register 27	COMDATA027			√		Undefined
03FEC461H	CAN0 message data byte 1 register 27	COMDATA127			√		Undefined
03FEC462H	CAN0 message data byte 23 register 27	COMDATA2327				√	Undefined
03FEC462H	CAN0 message data byte 2 register 27	COMDATA227			√		Undefined
03FEC463H	CAN0 message data byte 3 register 27	COMDATA327			√		Undefined
03FEC464H	CAN0 message data byte 45 register 27	COMDATA4527				√	Undefined
03FEC464H	CAN0 message data byte 4 register 27	COMDATA427			√		Undefined
03FEC465H	CAN0 message data byte 5 register 27	COMDATA527			√		Undefined
03FEC466H	CAN0 message data byte 67 register 27	COMDATA6727				√	Undefined
03FEC466H	CAN0 message data byte 6 register 27	COMDATA627			√		Undefined
03FEC467H	CAN0 message data byte 7 register 27	COMDATA727			√		Undefined
03FEC468H	CAN0 message data length register 27	COMDLC27			√		0000xxxxB
03FEC469H	CAN0 message configuration register 27	COMCONF27			√		Undefined
03FEC46AH	CAN0 message identifier register 27	COMIDL27				√	Undefined
03FEC46CH		COMIDH27			√	Undefined	
03FEC46EH	CAN0 message control register 27	COMCTRL27			√	00x00000 000xx000B	

Table 21-16. Register Access Types (16/34)

Address	Register Name	Symbol	R/W	Bit Manipulation Units			After Reset
				1 Bit	8 Bits	16 Bits	
03FEC480H	CAN0 message data byte 01 register 28	C0MDATA0128	R/W			√	Undefined
03FEC480H	CAN0 message data byte 0 register 28	C0MDATA028			√		Undefined
03FEC481H	CAN0 message data byte 1 register 28	C0MDATA128			√		Undefined
03FEC482H	CAN0 message data byte 23 register 28	C0MDATA2328				√	Undefined
03FEC482H	CAN0 message data byte 2 register 28	C0MDATA228			√		Undefined
03FEC483H	CAN0 message data byte 3 register 28	C0MDATA328			√		Undefined
03FEC484H	CAN0 message data byte 45 register 28	C0MDATA4528				√	Undefined
03FEC484H	CAN0 message data byte 4 register 28	C0MDATA428			√		Undefined
03FEC485H	CAN0 message data byte 5 register 28	C0MDATA528			√		Undefined
03FEC486H	CAN0 message data byte 67 register 28	C0MDATA6728				√	Undefined
03FEC486H	CAN0 message data byte 6 register 28	C0MDATA628			√		Undefined
03FEC487H	CAN0 message data byte 7 register 28	C0MDATA728			√		Undefined
03FEC488H	CAN0 message data length register 28	C0MDLC28			√		0000xxxxB
03FEC489H	CAN0 message configuration register 28	C0MCONF28			√		Undefined
03FEC48AH	CAN0 message identifier register 28	C0MIDL28				√	Undefined
03FEC48CH		C0MIDH28				√	Undefined
03FEC48EH	CAN0 message control register 28	C0MCTRL28				√	00x00000 000xx000B
03FEC4A0H	CAN0 message data byte 01 register 29	C0MDATA0129				√	Undefined
03FEC4A0H	CAN0 message data byte 0 register 29	C0MDATA029			√		Undefined
03FEC4A1H	CAN0 message data byte 1 register 29	C0MDATA129			√		Undefined
03FEC4A2H	CAN0 message data byte 23 register 29	C0MDATA2329				√	Undefined
03FEC4A2H	CAN0 message data byte 2 register 29	C0MDATA229			√		Undefined
03FEC4A3H	CAN0 message data byte 3 register 29	C0MDATA329			√		Undefined
03FEC4A4H	CAN0 message data byte 45 register 29	C0MDATA4529				√	Undefined
03FEC4A4H	CAN0 message data byte 4 register 29	C0MDATA429			√		Undefined
03FEC4A5H	CAN0 message data byte 5 register 29	C0MDATA529			√		Undefined
03FEC4A6H	CAN0 message data byte 67 register 29	C0MDATA6729				√	Undefined
03FEC4A6H	CAN0 message data byte 6 register 29	C0MDATA629			√		Undefined
03FEC4A7H	CAN0 message data byte 7 register 29	C0MDATA729		√		Undefined	
03FEC4A8H	CAN0 message data length register 29	C0MDLC29		√		0000xxxxB	
03FEC4A9H	CAN0 message configuration register 29	C0MCONF29		√		Undefined	
03FEC4AAH	CAN0 message identifier register 29	C0MIDL29			√	Undefined	
03FEC4ACH		C0MIDH29			√	Undefined	
03FEC4AEH	CAN0 message control register 29	C0MCTRL29			√	00x00000 000xx000B	

Table 21-16. Register Access Types (17/34)

Address	Register Name	Symbol	R/W	Bit Manipulation Units			After Reset
				1 Bit	8 Bits	16 Bits	
03FEC4C0H	CAN0 message data byte 01 register 30	COMDATA0130	R/W			√	Undefined
03FEC4C0H	CAN0 message data byte 0 register 30	COMDATA030			√		Undefined
03FEC4C1H	CAN0 message data byte 1 register 30	COMDATA130			√		Undefined
03FEC4C2H	CAN0 message data byte 23 register 30	COMDATA2330				√	Undefined
03FEC4C2H	CAN0 message data byte 2 register 30	COMDATA230			√		Undefined
03FEC4C3H	CAN0 message data byte 3 register 30	COMDATA330			√		Undefined
03FEC4C4H	CAN0 message data byte 45 register 30	COMDATA4530				√	Undefined
03FEC4C4H	CAN0 message data byte 4 register 30	COMDATA430			√		Undefined
03FEC4C5H	CAN0 message data byte 5 register 30	COMDATA530			√		Undefined
03FEC4C6H	CAN0 message data byte 67 register 30	COMDATA6730				√	Undefined
03FEC4C6H	CAN0 message data byte 6 register 30	COMDATA630			√		Undefined
03FEC4C7H	CAN0 message data byte 7 register 30	COMDATA730			√		Undefined
03FEC4C8H	CAN0 message data length register 30	COMDLC30			√		0000xxxxB
03FEC4C9H	CAN0 message configuration register 30	COMCONF30			√		Undefined
03FEC4CAH	CAN0 message identifier register 30	COMIDL30				√	Undefined
03FEC4CCH		COMIDH30				√	Undefined
03FEC4CEH	CAN0 message control register 30	COMCTRL30				√	00x00000 000xx000B
03FEC4E0H	CAN0 message data byte 01 register 31	COMDATA0131				√	Undefined
03FEC4E0H	CAN0 message data byte 0 register 31	COMDATA031			√		Undefined
03FEC4E1H	CAN0 message data byte 1 register 31	COMDATA131			√		Undefined
03FEC4E2H	CAN0 message data byte 23 register 31	COMDATA2331				√	Undefined
03FEC4E2H	CAN0 message data byte 2 register 31	COMDATA231			√		Undefined
03FEC4E3H	CAN0 message data byte 3 register 31	COMDATA331			√		Undefined
03FEC4E4H	CAN0 message data byte 45 register 31	COMDATA4531				√	Undefined
03FEC4E4H	CAN0 message data byte 4 register 31	COMDATA431			√		Undefined
03FEC4E5H	CAN0 message data byte 5 register 31	COMDATA531			√		Undefined
03FEC4E6H	CAN0 message data byte 67 register 31	COMDATA6731				√	Undefined
03FEC4E6H	CAN0 message data byte 6 register 31	COMDATA631			√		Undefined
03FEC4E7H	CAN0 message data byte 7 register 31	COMDATA731			√		Undefined
03FEC4E8H	CAN0 message data length register 31	COMDLC31			√		0000xxxxB
03FEC4E9H	CAN0 message configuration register 31	COMCONF31		√		Undefined	
03FEC4EAH	CAN0 message identifier register 31	COMIDL31			√	Undefined	
03FEC4ECH		COMIDH31			√	Undefined	
03FEC4EEH	CAN0 message control register 31	COMCTRL31			√	00x00000 000xx000B	



Table 21-16. Register Access Types (18/34)

Address	Register Name	Symbol	R/W	Bit Manipulation Units			After Reset
				1 Bit	8 Bits	16 Bits	
03FEC600H	CAN1 global control register	C1GMCTRL	R/W			√	0000H
03FEC602H	CAN1 global clock selection register	C1GMCS			√		0FH
03FEC606H	CAN1 global block transmission register	C1GMABT				√	0000H
03FEC608H	CAN1 global block transmission delay register	C1GMABTD			√		00H
03FEC640H	CAN1 module mask 1 register	C1MASK1L				√	Undefined
03FEC642H		C1MASK1H				√	Undefined
03FEC644H	CAN1 module mask 2 register	C1MASK2L				√	Undefined
03FEC646H		C1MASK2H				√	Undefined
03FEC648H	CAN1 module mask 3 register	C1MASK3L				√	Undefined
03FEC64AH		C1MASK3H				√	Undefined
03FEC64CH	CAN1 module mask 4 register	C1MASK4L				√	Undefined
03FEC64EH		C1MASK4H				√	Undefined
03FEC650H	CAN1 module control register	C1CTRL				√	0000H
03FEC652H	CAN1 module last error code register	C1LEC			√		00H
03FEC653H	CAN1 module information register	C1INFO		R		√	00H
03FEC654H	CAN1 module error counter register	C1ERC				√	0000H
03FEC656H	CAN1 module interrupt enable register	C1IE		R/W			√
03FEC658H	CAN1 module interrupt status register	C1INTS				√	0000H
03FEC65AH	CAN1 module bit-rate prescaler register	C1BRP			√		FFH
03FEC65CH	CAN1 module bit-rate register	C1BTR			√	370FH	
03FEC65EH	CAN1 module last in-pointer register	C1LIPT	R		√	Undefined	
03FEC660H	CAN1 module receive history list register	C1RGPT	R/W			√	xx02H
03FEC662H	CAN1 module last out-pointer register	C1LOPT	R		√		Undefined
03FEC664H	CAN1 module transmit history list register	C1TGPT	R/W			√	xx02H
03FEC666H	CAN1 module time stamp register	C1TS				√	0000H

Table 21-16. Register Access Types (19/34)

Address	Register Name	Symbol	R/W	Bit Manipulation Units			After Reset
				1 Bit	8 Bits	16 Bits	
03FEC700H	CAN1 message data byte 01 register 00	C1MDATA0100	R/W			√	Undefined
03FEC700H	CAN1 message data byte 0 register 00	C1MDATA000			√		Undefined
03FEC701H	CAN1 message data byte 1 register 00	C1MDATA100			√		Undefined
03FEC702H	CAN1 message data byte 23 register 00	C1MDATA2300				√	Undefined
03FEC702H	CAN1 message data byte 2 register 00	C1MDATA200			√		Undefined
03FEC703H	CAN1 message data byte 3 register 00	C1MDATA300			√		Undefined
03FEC704H	CAN1 message data byte 45 register 00	C1MDATA4500				√	Undefined
03FEC704H	CAN1 message data byte 4 register 00	C1MDATA400			√		Undefined
03FEC705H	CAN1 message data byte 5 register 00	C1MDATA500			√		Undefined
03FEC706H	CAN1 message data byte 67 register 00	C1MDATA6700				√	Undefined
03FEC706H	CAN1 message data byte 6 register 00	C1MDATA600			√		Undefined
03FEC707H	CAN1 message data byte 7 register 00	C1MDATA700			√		Undefined
03FEC708H	CAN1 message data length register 00	C1MDLC00			√		0000xxxxB
03FEC709H	CAN1 message configuration register 00	C1MCONF00			√		Undefined
03FEC70AH	CAN1 message identifier register 00	C1MIDL00				√	Undefined
03FEC70CH		C1MIDH00				√	Undefined
03FEC70EH	CAN1 message control register 00	C1MCTRL00				√	00x00000 000xx000B
03FEC720H	CAN1 message data byte 01 register 01	C1MDATA0101				√	Undefined
03FEC720H	CAN1 message data byte 0 register 01	C1MDATA001			√		Undefined
03FEC721H	CAN1 message data byte 1 register 01	C1MDATA101			√		Undefined
03FEC722H	CAN1 message data byte 23 register 01	C1MDATA2301				√	Undefined
03FEC722H	CAN1 message data byte 2 register 01	C1MDATA201			√		Undefined
03FEC723H	CAN1 message data byte 3 register 01	C1MDATA301			√		Undefined
03FEC724H	CAN1 message data byte 45 register 01	C1MDATA4501				√	Undefined
03FEC724H	CAN1 message data byte 4 register 01	C1MDATA401			√		Undefined
03FEC725H	CAN1 message data byte 5 register 01	C1MDATA501			√		Undefined
03FEC726H	CAN1 message data byte 67 register 01	C1MDATA6701				√	Undefined
03FEC726H	CAN1 message data byte 6 register 01	C1MDATA601			√		Undefined
03FEC727H	CAN1 message data byte 7 register 01	C1MDATA701			√		Undefined
03FEC728H	CAN1 message data length register 01	C1MDLC01			√		0000xxxxB
03FEC729H	CAN1 message configuration register 01	C1MCONF01			√		Undefined
03FEC72AH	CAN1 message identifier register 01	C1MIDL01				√	Undefined
03FEC72CH		C1MIDH01				√	Undefined
03FEC72EH	CAN1 message control register 01	C1MCTRL01				√	00x00000 000xx000B

Table 21-16. Register Access Types (20/34)

Address	Register Name	Symbol	R/W	Bit Manipulation Units			After Reset
				1 Bit	8 Bits	16 Bits	
03FEC740H	CAN1 message data byte 01 register 02	C1MDATA0102	R/W			√	Undefined
03FEC740H	CAN1 message data byte 0 register 02	C1MDATA002			√		Undefined
03FEC741H	CAN1 message data byte 1 register 02	C1MDATA102			√		Undefined
03FEC742H	CAN1 message data byte 23 register 02	C1MDATA2302				√	Undefined
03FEC742H	CAN1 message data byte 2 register 02	C1MDATA202			√		Undefined
03FEC743H	CAN1 message data byte 3 register 02	C1MDATA302			√		Undefined
03FEC744H	CAN1 message data byte 45 register 02	C1MDATA4502				√	Undefined
03FEC744H	CAN1 message data byte 4 register 02	C1MDATA402			√		Undefined
03FEC745H	CAN1 message data byte 5 register 02	C1MDATA502			√		Undefined
03FEC746H	CAN1 message data byte 67 register 02	C1MDATA6702				√	Undefined
03FEC746H	CAN1 message data byte 6 register 02	C1MDATA602			√		Undefined
03FEC747H	CAN1 message data byte 7 register 02	C1MDATA702			√		Undefined
03FEC748H	CAN1 message data length register 02	C1MDLC02			√		0000xxxxB
03FEC749H	CAN1 message configuration register 02	C1MCONF02			√		Undefined
03FEC74AH	CAN1 message identifier register 02	C1MIDL02				√	Undefined
03FEC74CH		C1MIDH02				√	Undefined
03FEC74EH	CAN1 message control register 02	C1MCTRL02				√	00x00000 000xx000B
03FEC760H	CAN1 message data byte 01 register 03	C1MDATA0103				√	Undefined
03FEC760H	CAN1 message data byte 0 register 03	C1MDATA003			√		Undefined
03FEC761H	CAN1 message data byte 1 register 03	C1MDATA103			√		Undefined
03FEC762H	CAN1 message data byte 23 register 03	C1MDATA2303				√	Undefined
03FEC762H	CAN1 message data byte 2 register 03	C1MDATA203			√		Undefined
03FEC763H	CAN1 message data byte 3 register 03	C1MDATA303			√		Undefined
03FEC764H	CAN1 message data byte 45 register 03	C1MDATA4503				√	Undefined
03FEC764H	CAN1 message data byte 4 register 03	C1MDATA403			√		Undefined
03FEC765H	CAN1 message data byte 5 register 03	C1MDATA503			√		Undefined
03FEC766H	CAN1 message data byte 67 register 03	C1MDATA6703				√	Undefined
03FEC766H	CAN1 message data byte 6 register 03	C1MDATA603		√		Undefined	
03FEC767H	CAN1 message data byte 7 register 03	C1MDATA703		√		Undefined	
03FEC768H	CAN1 message data length register 03	C1MDLC03		√		0000xxxxB	
03FEC769H	CAN1 message configuration register 03	C1MCONF03		√		Undefined	
03FEC76AH	CAN1 message identifier register 03	C1MIDL03			√	Undefined	
03FEC76CH		C1MIDH03			√	Undefined	
03FEC76EH	CAN1 message control register 03	C1MCTRL03			√	00x00000 000xx000B	

Table 21-16. Register Access Types (21/34)

Address	Register Name	Symbol	R/W	Bit Manipulation Units			After Reset
				1 Bit	8 Bits	16 Bits	
03FEC780H	CAN1 message data byte 01 register 04	C1MDATA0104	R/W			√	Undefined
03FEC780H	CAN1 message data byte 0 register 04	C1MDATA004			√		Undefined
03FEC781H	CAN1 message data byte 1 register 04	C1MDATA104			√		Undefined
03FEC782H	CAN1 message data byte 23 register 04	C1MDATA2304				√	Undefined
03FEC782H	CAN1 message data byte 2 register 04	C1MDATA204			√		Undefined
03FEC783H	CAN1 message data byte 3 register 04	C1MDATA304			√		Undefined
03FEC784H	CAN1 message data byte 45 register 04	C1MDATA4504				√	Undefined
03FEC784H	CAN1 message data byte 4 register 04	C1MDATA404			√		Undefined
03FEC785H	CAN1 message data byte 5 register 04	C1MDATA504			√		Undefined
03FEC786H	CAN1 message data byte 67 register 04	C1MDATA6704				√	Undefined
03FEC786H	CAN1 message data byte 6 register 04	C1MDATA604			√		Undefined
03FEC787H	CAN1 message data byte 7 register 04	C1MDATA704			√		Undefined
03FEC788H	CAN1 message data length register 04	C1MDLC04			√		0000xxxxB
03FEC789H	CAN1 message configuration register 04	C1MCONF04			√		Undefined
03FEC78AH	CAN1 message identifier register 04	C1MIDL04				√	Undefined
03FEC78CH		C1MIDH04				√	Undefined
03FEC78EH	CAN1 message control register 04	C1MCTRL04				√	00x00000 000xx000B
03FEC7A0H	CAN1 message data byte 01 register 05	C1MDATA0105				√	Undefined
03FEC7A0H	CAN1 message data byte 0 register 05	C1MDATA005			√		Undefined
03FEC7A1H	CAN1 message data byte 1 register 05	C1MDATA105			√		Undefined
03FEC7A2H	CAN1 message data byte 23 register 05	C1MDATA2305				√	Undefined
03FEC7A2H	CAN1 message data byte 2 register 05	C1MDATA205			√		Undefined
03FEC7A3H	CAN1 message data byte 3 register 05	C1MDATA305			√		Undefined
03FEC7A4H	CAN1 message data byte 45 register 05	C1MDATA4505				√	Undefined
03FEC7A4H	CAN1 message data byte 4 register 05	C1MDATA405			√		Undefined
03FEC7A5H	CAN1 message data byte 5 register 05	C1MDATA505			√		Undefined
03FEC7A6H	CAN1 message data byte 67 register 05	C1MDATA6705				√	Undefined
03FEC7A6H	CAN1 message data byte 6 register 05	C1MDATA605			√		Undefined
03FEC7A7H	CAN1 message data byte 7 register 05	C1MDATA705			√		Undefined
03FEC7A8H	CAN1 message data length register 05	C1MDLC05			√		0000xxxxB
03FEC7A9H	CAN1 message configuration register 05	C1MCONF05		√		Undefined	
03FEC7AAH	CAN1 message identifier register 05	C1MIDL05			√	Undefined	
03FEC7ACH		C1MIDH05			√	Undefined	
03FEC7AEH	CAN1 message control register 05	C1MCTRL05			√	00x00000 000xx000B	

Table 21-16. Register Access Types (22/34)

Address	Register Name	Symbol	R/W	Bit Manipulation Units			After Reset
				1 Bit	8 Bits	16 Bits	
03FEC7C0H	CAN1 message data byte 01 register 06	C1MDATA0106	R/W			√	Undefined
03FEC7C0H	CAN1 message data byte 0 register 06	C1MDATA006			√		Undefined
03FEC7C1H	CAN1 message data byte 1 register 06	C1MDATA106			√		Undefined
03FEC7C2H	CAN1 message data byte 23 register 06	C1MDATA2306				√	Undefined
03FEC7C2H	CAN1 message data byte 2 register 06	C1MDATA206			√		Undefined
03FEC7C3H	CAN1 message data byte 3 register 06	C1MDATA306			√		Undefined
03FEC7C4H	CAN1 message data byte 45 register 06	C1MDATA4506				√	Undefined
03FEC7C4H	CAN1 message data byte 4 register 06	C1MDATA406			√		Undefined
03FEC7C5H	CAN1 message data byte 5 register 06	C1MDATA506			√		Undefined
03FEC7C6H	CAN1 message data byte 67 register 06	C1MDATA6706				√	Undefined
03FEC7C6H	CAN1 message data byte 6 register 06	C1MDATA606			√		Undefined
03FEC7C7H	CAN1 message data byte 7 register 06	C1MDATA706			√		Undefined
03FEC7C8H	CAN1 message data length register 06	C1MDLC06			√		0000xxxxB
03FEC7C9H	CAN1 message configuration register 06	C1MCONF06			√		Undefined
03FEC7CAH	CAN1 message identifier register 06	C1MIDL06				√	Undefined
03FEC7CCH		C1MIDH06				√	Undefined
03FEC7CEH	CAN1 message control register 06	C1MCTRL06				√	00x00000 000xx000B
03FEC7E0H	CAN1 message data byte 01 register 07	C1MDATA0107				√	Undefined
03FEC7E0H	CAN1 message data byte 0 register 07	C1MDATA007			√		Undefined
03FEC7E1H	CAN1 message data byte 1 register 07	C1MDATA107			√		Undefined
03FEC7E2H	CAN1 message data byte 23 register 07	C1MDATA2307			√	Undefined	
03FEC7E2H	CAN1 message data byte 2 register 07	C1MDATA207		√		Undefined	
03FEC7E3H	CAN1 message data byte 3 register 07	C1MDATA307		√		Undefined	
03FEC7E4H	CAN1 message data byte 45 register 07	C1MDATA4507			√	Undefined	
03FEC7E4H	CAN1 message data byte 4 register 07	C1MDATA407		√		Undefined	
03FEC7E5H	CAN1 message data byte 5 register 07	C1MDATA507		√		Undefined	
03FEC7E6H	CAN1 message data byte 67 register 07	C1MDATA6707			√	Undefined	
03FEC7E6H	CAN1 message data byte 6 register 07	C1MDATA607		√		Undefined	
03FEC7E7H	CAN1 message data byte 7 register 07	C1MDATA707		√		Undefined	
03FEC7E8H	CAN1 message data length register 07	C1MDLC07		√		0000xxxxB	
03FEC7E9H	CAN1 message configuration register 07	C1MCONF07		√		Undefined	
03FEC7EAH	CAN1 message identifier register 07	C1MIDL07			√	Undefined	
03FEC7ECH		C1MIDH07			√	Undefined	
03FEC7EEH	CAN1 message control register 07	C1MCTRL07			√	00x00000 000xx000B	

Table 21-16. Register Access Types (23/34)

Address	Register Name	Symbol	R/W	Bit Manipulation Units			After Reset
				1 Bit	8 Bits	16 Bits	
03FEC800H	CAN1 message data byte 01 register 08	C1MDATA0108	R/W			√	Undefined
03FEC800H	CAN1 message data byte 0 register 08	C1MDATA008			√		Undefined
03FEC801H	CAN1 message data byte 1 register 08	C1MDATA108			√		Undefined
03FEC802H	CAN1 message data byte 23 register 08	C1MDATA2308				√	Undefined
03FEC802H	CAN1 message data byte 2 register 08	C1MDATA208			√		Undefined
03FEC803H	CAN1 message data byte 3 register 08	C1MDATA308			√		Undefined
03FEC804H	CAN1 message data byte 45 register 08	C1MDATA4508				√	Undefined
03FEC804H	CAN1 message data byte 4 register 08	C1MDATA408			√		Undefined
03FEC805H	CAN1 message data byte 5 register 08	C1MDATA508			√		Undefined
03FEC806H	CAN1 message data byte 67 register 08	C1MDATA6708				√	Undefined
03FEC806H	CAN1 message data byte 6 register 08	C1MDATA608			√		Undefined
03FEC807H	CAN1 message data byte 7 register 08	C1MDATA708			√		Undefined
03FEC808H	CAN1 message data length register 08	C1MDLC08			√		0000xxxxB
03FEC809H	CAN1 message configuration register 08	C1MCONF08			√		Undefined
03FEC80AH	CAN1 message identifier register 08	C1MIDL08				√	Undefined
03FEC80CH		C1MIDH08				√	Undefined
03FEC80EH	CAN1 message control register 08	C1MCTRL08				√	00x00000 000xx000B
03FEC820H	CAN1 message data byte 01 register 09	C1MDATA0109				√	Undefined
03FEC820H	CAN1 message data byte 0 register 09	C1MDATA009			√		Undefined
03FEC821H	CAN1 message data byte 1 register 09	C1MDATA109			√		Undefined
03FEC822H	CAN1 message data byte 23 register 09	C1MDATA2309				√	Undefined
03FEC822H	CAN1 message data byte 2 register 09	C1MDATA209			√		Undefined
03FEC823H	CAN1 message data byte 3 register 09	C1MDATA309			√		Undefined
03FEC824H	CAN1 message data byte 45 register 09	C1MDATA4509				√	Undefined
03FEC824H	CAN1 message data byte 4 register 09	C1MDATA409			√		Undefined
03FEC825H	CAN1 message data byte 5 register 09	C1MDATA509			√		Undefined
03FEC826H	CAN1 message data byte 67 register 09	C1MDATA6709				√	Undefined
03FEC826H	CAN1 message data byte 6 register 09	C1MDATA609			√		Undefined
03FEC827H	CAN1 message data byte 7 register 09	C1MDATA709			√		Undefined
03FEC828H	CAN1 message data length register 09	C1MDLC09			√		0000xxxxB
03FEC829H	CAN1 message configuration register 09	C1MCONF09			√		Undefined
03FEC82AH	CAN1 message identifier register 09	C1MIDL09				√	Undefined
03FEC82CH		C1MIDH09			√	Undefined	
03FEC82EH	CAN1 message control register 09	C1MCTRL09			√	00x00000 000xx000B	

Table 21-16. Register Access Types (24/34)

Address	Register Name	Symbol	R/W	Bit Manipulation Units			After Reset
				1 Bit	8 Bits	16 Bits	
03FEC840H	CAN1 message data byte 01 register 10	C1MDATA0110	R/W			√	Undefined
03FEC840H	CAN1 message data byte 0 register 10	C1MDATA010			√		Undefined
03FEC841H	CAN1 message data byte 1 register 10	C1MDATA110			√		Undefined
03FEC842H	CAN1 message data byte 23 register 10	C1MDATA2310				√	Undefined
03FEC842H	CAN1 message data byte 2 register 10	C1MDATA210			√		Undefined
03FEC843H	CAN1 message data byte 3 register 10	C1MDATA310			√		Undefined
03FEC844H	CAN1 message data byte 45 register 10	C1MDATA4510				√	Undefined
03FEC844H	CAN1 message data byte 4 register 10	C1MDATA410			√		Undefined
03FEC845H	CAN1 message data byte 5 register 10	C1MDATA510			√		Undefined
03FEC846H	CAN1 message data byte 67 register 10	C1MDATA6710				√	Undefined
03FEC846H	CAN1 message data byte 6 register 10	C1MDATA610			√		Undefined
03FEC847H	CAN1 message data byte 7 register 10	C1MDATA710			√		Undefined
03FEC848H	CAN1 message data length register 10	C1MDLC10			√		0000xxxxB
03FEC849H	CAN1 message configuration register 10	C1MCONF10			√		Undefined
03FEC84AH	CAN1 message identifier register 10	C1MIDL10				√	Undefined
03FEC84CH		C1MIDH10				√	Undefined
03FEC84EH	CAN1 message control register 10	C1MCTRL10				√	00x00000 000xx000B
03FEC860H	CAN1 message data byte 01 register 11	C1MDATA0111				√	Undefined
03FEC860H	CAN1 message data byte 0 register 11	C1MDATA011			√		Undefined
03FEC861H	CAN1 message data byte 1 register 11	C1MDATA111			√		Undefined
03FEC862H	CAN1 message data byte 23 register 11	C1MDATA2311				√	Undefined
03FEC862H	CAN1 message data byte 2 register 11	C1MDATA211			√		Undefined
03FEC863H	CAN1 message data byte 3 register 11	C1MDATA311			√		Undefined
03FEC864H	CAN1 message data byte 45 register 11	C1MDATA4511				√	Undefined
03FEC864H	CAN1 message data byte 4 register 11	C1MDATA411		√		Undefined	
03FEC865H	CAN1 message data byte 5 register 11	C1MDATA511		√		Undefined	
03FEC866H	CAN1 message data byte 67 register 11	C1MDATA6711			√	Undefined	
03FEC866H	CAN1 message data byte 6 register 11	C1MDATA611		√		Undefined	
03FEC867H	CAN1 message data byte 7 register 11	C1MDATA711		√		Undefined	
03FEC868H	CAN1 message data length register 11	C1MDLC11		√		0000xxxxB	
03FEC869H	CAN1 message configuration register 11	C1MCONF11		√		Undefined	
03FEC86AH	CAN1 message identifier register 11	C1MIDL11			√	Undefined	
03FEC86CH		C1MIDH11			√	Undefined	
03FEC86EH	CAN1 message control register 11	C1MCTRL11			√	00x00000 000xx000B	

Table 21-16. Register Access Types (25/34)

Address	Register Name	Symbol	R/W	Bit Manipulation Units			After Reset
				1 Bit	8 Bits	16 Bits	
03FEC880H	CAN1 message data byte 01 register 12	C1MDATA0112	R/W			√	Undefined
03FEC880H	CAN1 message data byte 0 register 12	C1MDATA012			√		Undefined
03FEC881H	CAN1 message data byte 1 register 12	C1MDATA112			√		Undefined
03FEC882H	CAN1 message data byte 23 register 12	C1MDATA2312				√	Undefined
03FEC882H	CAN1 message data byte 2 register 12	C1MDATA212			√		Undefined
03FEC883H	CAN1 message data byte 3 register 12	C1MDATA312			√		Undefined
03FEC884H	CAN1 message data byte 45 register 12	C1MDATA4512				√	Undefined
03FEC884H	CAN1 message data byte 4 register 12	C1MDATA412			√		Undefined
03FEC885H	CAN1 message data byte 5 register 12	C1MDATA512			√		Undefined
03FEC886H	CAN1 message data byte 67 register 12	C1MDATA6712				√	Undefined
03FEC886H	CAN1 message data byte 6 register 12	C1MDATA612			√		Undefined
03FEC887H	CAN1 message data byte 7 register 12	C1MDATA712			√		Undefined
03FEC888H	CAN1 message data length register 12	C1MDLC12			√		0000xxxxB
03FEC889H	CAN1 message configuration register 12	C1MCONF12			√		Undefined
03FEC88AH	CAN1 message identifier register 12	C1MIDL12				√	Undefined
03FEC88CH		C1MIDH12				√	Undefined
03FEC88EH	CAN1 message control register 12	C1MCTRL12				√	00x00000 000xx000B
03FEC8A0H	CAN1 message data byte 01 register 13	C1MDATA0113				√	Undefined
03FEC8A0H	CAN1 message data byte 0 register 13	C1MDATA013			√		Undefined
03FEC8A1H	CAN1 message data byte 1 register 13	C1MDATA113			√		Undefined
03FEC8A2H	CAN1 message data byte 23 register 13	C1MDATA2313				√	Undefined
03FEC8A2H	CAN1 message data byte 2 register 13	C1MDATA213			√		Undefined
03FEC8A3H	CAN1 message data byte 3 register 13	C1MDATA313			√		Undefined
03FEC8A4H	CAN1 message data byte 45 register 13	C1MDATA4513				√	Undefined
03FEC8A4H	CAN1 message data byte 4 register 13	C1MDATA413			√		Undefined
03FEC8A5H	CAN1 message data byte 5 register 13	C1MDATA513			√		Undefined
03FEC8A6H	CAN1 message data byte 67 register 13	C1MDATA6713				√	Undefined
03FEC8A6H	CAN1 message data byte 6 register 13	C1MDATA613			√		Undefined
03FEC8A7H	CAN1 message data byte 7 register 13	C1MDATA713			√		Undefined
03FEC8A8H	CAN1 message data length register 13	C1MDLC13			√		0000xxxxB
03FEC8A9H	CAN1 message configuration register 13	C1MCONF13		√		Undefined	
03FEC8AAH	CAN1 message identifier register 13	C1MIDL13			√	Undefined	
03FEC8ACH		C1MIDH13			√	Undefined	
03FEC8AEH	CAN1 message control register 13	C1MCTRL13			√	00x00000 000xx000B	



Table 21-16. Register Access Types (26/34)

Address	Register Name	Symbol	R/W	Bit Manipulation Units			After Reset
				1 Bit	8 Bits	16 Bits	
03FEC8C0H	CAN1 message data byte 01 register 14	C1MDATA0114	R/W			√	Undefined
03FEC8C0H	CAN1 message data byte 0 register 14	C1MDATA014			√		Undefined
03FEC8C1H	CAN1 message data byte 1 register 14	C1MDATA114			√		Undefined
03FEC8C2H	CAN1 message data byte 23 register 14	C1MDATA2314				√	Undefined
03FEC8C2H	CAN1 message data byte 2 register 14	C1MDATA214			√		Undefined
03FEC8C3H	CAN1 message data byte 3 register 14	C1MDATA314			√		Undefined
03FEC8C4H	CAN1 message data byte 45 register 14	C1MDATA4514				√	Undefined
03FEC8C4H	CAN1 message data byte 4 register 14	C1MDATA414			√		Undefined
03FEC8C5H	CAN1 message data byte 5 register 14	C1MDATA514			√		Undefined
03FEC8C6H	CAN1 message data byte 67 register 14	C1MDATA6714				√	Undefined
03FEC8C6H	CAN1 message data byte 6 register 14	C1MDATA614			√		Undefined
03FEC8C7H	CAN1 message data byte 7 register 14	C1MDATA714			√		Undefined
03FEC8C8H	CAN1 message data length register 14	C1MDLC14			√		0000xxxxB
03FEC8C9H	CAN1 message configuration register 14	C1MCONF14			√		Undefined
03FEC8CAH	CAN1 message identifier register 14	C1MIDL14				√	Undefined
03FEC8CCH		C1MIDH14				√	Undefined
03FEC8CEH	CAN1 message control register 14	C1MCTRL14				√	00x00000 000xx000B
03FEC8E0H	CAN1 message data byte 01 register 15	C1MDATA0115				√	Undefined
03FEC8E0H	CAN1 message data byte 0 register 15	C1MDATA015			√		Undefined
03FEC8E1H	CAN1 message data byte 1 register 15	C1MDATA115			√		Undefined
03FEC8E2H	CAN1 message data byte 23 register 15	C1MDATA2315				√	Undefined
03FEC8E2H	CAN1 message data byte 2 register 15	C1MDATA215			√		Undefined
03FEC8E3H	CAN1 message data byte 3 register 15	C1MDATA315			√		Undefined
03FEC8E4H	CAN1 message data byte 45 register 15	C1MDATA4515				√	Undefined
03FEC8E4H	CAN1 message data byte 4 register 15	C1MDATA415			√		Undefined
03FEC8E5H	CAN1 message data byte 5 register 15	C1MDATA515			√		Undefined
03FEC8E6H	CAN1 message data byte 67 register 15	C1MDATA6715			√	Undefined	
03FEC8E6H	CAN1 message data byte 6 register 15	C1MDATA615		√		Undefined	
03FEC8E7H	CAN1 message data byte 7 register 15	C1MDATA715		√		Undefined	
03FEC8E8H	CAN1 message data length register 15	C1MDLC15		√		0000xxxxB	
03FEC8E9H	CAN1 message configuration register 15	C1MCONF15		√		Undefined	
03FEC8EAH	CAN1 message identifier register 15	C1MIDL15			√	Undefined	
03FEC8ECH		C1MIDH15			√	Undefined	
03FEC8EEH	CAN1 message control register 15	C1MCTRL15			√	00x00000 000xx000B	

Table 21-16. Register Access Types (27/34)

Address	Register Name	Symbol	R/W	Bit Manipulation Units			After Reset
				1 Bit	8 Bits	16 Bits	
03FEC900H	CAN1 message data byte 01 register 16	C1MDATA0116	R/W			√	Undefined
03FEC900H	CAN1 message data byte 0 register 16	C1MDATA016			√		Undefined
03FEC901H	CAN1 message data byte 1 register 16	C1MDATA116			√		Undefined
03FEC902H	CAN1 message data byte 23 register 16	C1MDATA2316				√	Undefined
03FEC902H	CAN1 message data byte 2 register 16	C1MDATA216			√		Undefined
03FEC903H	CAN1 message data byte 3 register 16	C1MDATA316			√		Undefined
03FEC904H	CAN1 message data byte 45 register 16	C1MDATA4516				√	Undefined
03FEC904H	CAN1 message data byte 4 register 16	C1MDATA416			√		Undefined
03FEC905H	CAN1 message data byte 5 register 16	C1MDATA516			√		Undefined
03FEC906H	CAN1 message data byte 67 register 16	C1MDATA6716				√	Undefined
03FEC906H	CAN1 message data byte 6 register 16	C1MDATA616			√		Undefined
03FEC907H	CAN1 message data byte 7 register 16	C1MDATA716			√		Undefined
03FEC908H	CAN1 message data length register 16	C1MDLC16			√		0000xxxxB
03FEC909H	CAN1 message configuration register 16	C1MCONF16			√		Undefined
03FEC90AH	CAN1 message identifier register 16	C1MIDL16				√	Undefined
03FEC90CH		C1MIDH16				√	Undefined
03FEC90EH	CAN1 message control register 16	C1MCTRL16				√	00x00000 000xx000B
03FEC920H	CAN1 message data byte 01 register 17	C1MDATA0117				√	Undefined
03FEC920H	CAN1 message data byte 0 register 17	C1MDATA017			√		Undefined
03FEC921H	CAN1 message data byte 1 register 17	C1MDATA117			√		Undefined
03FEC922H	CAN1 message data byte 23 register 17	C1MDATA2317				√	Undefined
03FEC922H	CAN1 message data byte 2 register 17	C1MDATA217			√		Undefined
03FEC923H	CAN1 message data byte 3 register 17	C1MDATA317			√		Undefined
03FEC924H	CAN1 message data byte 45 register 17	C1MDATA4517				√	Undefined
03FEC924H	CAN1 message data byte 4 register 17	C1MDATA417			√		Undefined
03FEC925H	CAN1 message data byte 5 register 17	C1MDATA517			√		Undefined
03FEC926H	CAN1 message data byte 67 register 17	C1MDATA6717				√	Undefined
03FEC926H	CAN1 message data byte 6 register 17	C1MDATA617			√		Undefined
03FEC927H	CAN1 message data byte 7 register 17	C1MDATA717			√		Undefined
03FEC928H	CAN1 message data length register 17	C1MDLC17			√		0000xxxxB
03FEC929H	CAN1 message configuration register 17	C1MCONF17		√		Undefined	
03FEC92AH	CAN1 message identifier register 17	C1MIDL17			√	Undefined	
03FEC92CH		C1MIDH17			√	Undefined	
03FEC92EH	CAN1 message control register 17	C1MCTRL17			√	00x00000 000xx000B	

Table 21-16. Register Access Types (28/34)

Address	Register Name	Symbol	R/W	Bit Manipulation Units			After Reset
				1 Bit	8 Bits	16 Bits	
03FEC940H	CAN1 message data byte 01 register 18	C1MDATA0118	R/W			√	Undefined
03FEC940H	CAN1 message data byte 0 register 18	C1MDATA018			√		Undefined
03FEC941H	CAN1 message data byte 1 register 18	C1MDATA118			√		Undefined
03FEC942H	CAN1 message data byte 23 register 18	C1MDATA2318				√	Undefined
03FEC942H	CAN1 message data byte 2 register 18	C1MDATA218			√		Undefined
03FEC943H	CAN1 message data byte 3 register 18	C1MDATA318			√		Undefined
03FEC944H	CAN1 message data byte 45 register 18	C1MDATA4518				√	Undefined
03FEC944H	CAN1 message data byte 4 register 18	C1MDATA418			√		Undefined
03FEC945H	CAN1 message data byte 5 register 18	C1MDATA518			√		Undefined
03FEC946H	CAN1 message data byte 67 register 18	C1MDATA6718				√	Undefined
03FEC946H	CAN1 message data byte 6 register 18	C1MDATA618			√		Undefined
03FEC947H	CAN1 message data byte 7 register 18	C1MDATA718			√		Undefined
03FEC948H	CAN1 message data length register 18	C1MDLC18			√		0000xxxxB
03FEC949H	CAN1 message configuration register 18	C1MCONF18			√		Undefined
03FEC94AH	CAN1 message identifier register 18	C1MIDL18				√	Undefined
03FEC94CH		C1MIDH18				√	Undefined
03FEC94EH	CAN1 message control register 18	C1MCTRL18				√	00x00000 000xx000B
03FEC960H	CAN1 message data byte 01 register 19	C1MDATA0119				√	Undefined
03FEC960H	CAN1 message data byte 0 register 19	C1MDATA019			√		Undefined
03FEC961H	CAN1 message data byte 1 register 19	C1MDATA119			√		Undefined
03FEC962H	CAN1 message data byte 23 register 19	C1MDATA2319				√	Undefined
03FEC962H	CAN1 message data byte 2 register 19	C1MDATA219			√		Undefined
03FEC963H	CAN1 message data byte 3 register 19	C1MDATA319			√		Undefined
03FEC964H	CAN1 message data byte 45 register 19	C1MDATA4519				√	Undefined
03FEC964H	CAN1 message data byte 4 register 19	C1MDATA419		√		Undefined	
03FEC965H	CAN1 message data byte 5 register 19	C1MDATA519		√		Undefined	
03FEC966H	CAN1 message data byte 67 register 19	C1MDATA6719			√	Undefined	
03FEC966H	CAN1 message data byte 6 register 19	C1MDATA619		√		Undefined	
03FEC967H	CAN1 message data byte 7 register 19	C1MDATA719		√		Undefined	
03FEC968H	CAN1 message data length register 19	C1MDLC19		√		0000xxxxB	
03FEC969H	CAN1 message configuration register 19	C1MCONF19		√		Undefined	
03FEC96AH	CAN1 message identifier register 19	C1MIDL19			√	Undefined	
03FEC96CH		C1MIDH19			√	Undefined	
03FEC96EH	CAN1 message control register 19	C1MCTRL19			√	00x00000 000xx000B	

Table 21-16. Register Access Types (29/34)

Address	Register Name	Symbol	R/W	Bit Manipulation Units			After Reset
				1 Bit	8 Bits	16 Bits	
03FEC980H	CAN1 message data byte 01 register 20	C1MDATA0120	R/W			√	Undefined
03FEC980H	CAN1 message data byte 0 register 20	C1MDATA020			√		Undefined
03FEC981H	CAN1 message data byte 1 register 20	C1MDATA120			√		Undefined
03FEC982H	CAN1 message data byte 23 register 20	C1MDATA2320				√	Undefined
03FEC982H	CAN1 message data byte 2 register 20	C1MDATA220			√		Undefined
03FEC983H	CAN1 message data byte 3 register 20	C1MDATA320			√		Undefined
03FEC984H	CAN1 message data byte 45 register 20	C1MDATA4520				√	Undefined
03FEC984H	CAN1 message data byte 4 register 20	C1MDATA420			√		Undefined
03FEC985H	CAN1 message data byte 5 register 20	C1MDATA520			√		Undefined
03FEC986H	CAN1 message data byte 67 register 20	C1MDATA6720				√	Undefined
03FEC986H	CAN1 message data byte 6 register 20	C1MDATA620			√		Undefined
03FEC987H	CAN1 message data byte 7 register 20	C1MDATA720			√		Undefined
03FEC988H	CAN1 message data length register 20	C1MDLC20			√		0000xxxxB
03FEC989H	CAN1 message configuration register 20	C1MCONF20			√		Undefined
03FEC98AH	CAN1 message identifier register 20	C1MIDL20				√	Undefined
03FEC98CH		C1MIDH20				√	Undefined
03FEC98EH	CAN1 message control register 20	C1MCTRL20				√	00x00000 000xx000B
03FEC9A0H	CAN1 message data byte 01 register 21	C1MDATA0121				√	Undefined
03FEC9A0H	CAN1 message data byte 0 register 21	C1MDATA021			√		Undefined
03FEC9A1H	CAN1 message data byte 1 register 21	C1MDATA121			√		Undefined
03FEC9A2H	CAN1 message data byte 23 register 21	C1MDATA2321				√	Undefined
03FEC9A2H	CAN1 message data byte 2 register 21	C1MDATA221			√		Undefined
03FEC9A3H	CAN1 message data byte 3 register 21	C1MDATA321			√		Undefined
03FEC9A4H	CAN1 message data byte 45 register 21	C1MDATA4521				√	Undefined
03FEC9A4H	CAN1 message data byte 4 register 21	C1MDATA421			√		Undefined
03FEC9A5H	CAN1 message data byte 5 register 21	C1MDATA521			√		Undefined
03FEC9A6H	CAN1 message data byte 67 register 21	C1MDATA6721				√	Undefined
03FEC9A6H	CAN1 message data byte 6 register 21	C1MDATA621			√		Undefined
03FEC9A7H	CAN1 message data byte 7 register 21	C1MDATA721			√		Undefined
03FEC9A8H	CAN1 message data length register 21	C1MDLC21			√		0000xxxxB
03FEC9A9H	CAN1 message configuration register 21	C1MCONF21			√		Undefined
03FEC9AAH	CAN1 message identifier register 21	C1MIDL21				√	Undefined
03FEC9ACH		C1MIDH21				√	Undefined
03FEC9AEH	CAN1 message control register 21	C1MCTRL21				√	00x00000 000xx000B

Table 21-16. Register Access Types (30/34)

Address	Register Name	Symbol	R/W	Bit Manipulation Units			After Reset
				1 Bit	8 Bits	16 Bits	
03FEC9C0H	CAN1 message data byte 01 register 22	C1MDATA0122	R/W			√	Undefined
03FEC9C0H	CAN1 message data byte 0 register 22	C1MDATA022			√		Undefined
03FEC9C1H	CAN1 message data byte 1 register 22	C1MDATA122			√		Undefined
03FEC9C2H	CAN1 message data byte 23 register 22	C1MDATA2322				√	Undefined
03FEC9C2H	CAN1 message data byte 2 register 22	C1MDATA222			√		Undefined
03FEC9C3H	CAN1 message data byte 3 register 22	C1MDATA322			√		Undefined
03FEC9C4H	CAN1 message data byte 45 register 22	C1MDATA4522				√	Undefined
03FEC9C4H	CAN1 message data byte 4 register 22	C1MDATA422			√		Undefined
03FEC9C5H	CAN1 message data byte 5 register 22	C1MDATA522			√		Undefined
03FEC9C6H	CAN1 message data byte 67 register 22	C1MDATA6722				√	Undefined
03FEC9C6H	CAN1 message data byte 6 register 22	C1MDATA622			√		Undefined
03FEC9C7H	CAN1 message data byte 7 register 22	C1MDATA722			√		Undefined
03FEC9C8H	CAN1 message data length register 22	C1MDLC22			√		0000xxxxB
03FEC9C9H	CAN1 message configuration register 22	C1MCONF22			√		Undefined
03FEC9CAH	CAN1 message identifier register 22	C1MIDL22				√	Undefined
03FEC9CCH		C1MIDH22				√	Undefined
03FEC9CEH	CAN1 message control register 22	C1MCTRL22				√	00x00000 000xx000B
03FEC9E0H	CAN1 message data byte 01 register 23	C1MDATA0123				√	Undefined
03FEC9E0H	CAN1 message data byte 0 register 23	C1MDATA023			√		Undefined
03FEC9E1H	CAN1 message data byte 1 register 23	C1MDATA123			√		Undefined
03FEC9E2H	CAN1 message data byte 23 register 23	C1MDATA2323				√	Undefined
03FEC9E2H	CAN1 message data byte 2 register 23	C1MDATA223			√		Undefined
03FEC9E3H	CAN1 message data byte 3 register 23	C1MDATA323			√		Undefined
03FEC9E4H	CAN1 message data byte 45 register 23	C1MDATA4523				√	Undefined
03FEC9E4H	CAN1 message data byte 4 register 23	C1MDATA423		√		Undefined	
03FEC9E5H	CAN1 message data byte 5 register 23	C1MDATA523		√		Undefined	
03FEC9E6H	CAN1 message data byte 67 register 23	C1MDATA6723			√	Undefined	
03FEC9E6H	CAN1 message data byte 6 register 23	C1MDATA623		√		Undefined	
03FEC9E7H	CAN1 message data byte 7 register 23	C1MDATA723		√		Undefined	
03FEC9E8H	CAN1 message data length register 23	C1MDLC23		√		0000xxxxB	
03FEC9E9H	CAN1 message configuration register 23	C1MCONF23		√		Undefined	
03FEC9EAH	CAN1 message identifier register 23	C1MIDL23			√	Undefined	
03FEC9ECH		C1MIDH23			√	Undefined	
03FEC9EEH	CAN1 message control register 23	C1MCTRL23			√	00x00000 000xx000B	

Table 21-16. Register Access Types (31/34)

Address	Register Name	Symbol	R/W	Bit Manipulation Units			After Reset
				1 Bit	8 Bits	16 Bits	
03FECA00H	CAN1 message data byte 01 register 24	C1MDATA0124	R/W			√	Undefined
03FECA00H	CAN1 message data byte 0 register 24	C1MDATA024			√		Undefined
03FECA01H	CAN1 message data byte 1 register 24	C1MDATA124			√		Undefined
03FECA02H	CAN1 message data byte 23 register 24	C1MDATA2324				√	Undefined
03FECA02H	CAN1 message data byte 2 register 24	C1MDATA224			√		Undefined
03FECA03H	CAN1 message data byte 3 register 24	C1MDATA324			√		Undefined
03FECA04H	CAN1 message data byte 45 register 24	C1MDATA4524				√	Undefined
03FECA04H	CAN1 message data byte 4 register 24	C1MDATA424			√		Undefined
03FECA05H	CAN1 message data byte 5 register 24	C1MDATA524			√		Undefined
03FECA06H	CAN1 message data byte 67 register 24	C1MDATA6724				√	Undefined
03FECA06H	CAN1 message data byte 6 register 24	C1MDATA624			√		Undefined
03FECA07H	CAN1 message data byte 7 register 24	C1MDATA724			√		Undefined
03FECA08H	CAN1 message data length register 24	C1MDLC24			√		0000xxxxB
03FECA09H	CAN1 message configuration register 24	C1MCONF24			√		Undefined
03FECA0AH	CAN1 message identifier register 24	C1MIDL24				√	Undefined
03FECA0CH		C1MIDH24				√	Undefined
03FECA0EH	CAN1 message control register 24	C1MCTRL24				√	00x00000 000xx000B
03FECA20H	CAN1 message data byte 01 register 25	C1MDATA0125				√	Undefined
03FECA20H	CAN1 message data byte 0 register 25	C1MDATA025			√		Undefined
03FECA21H	CAN1 message data byte 1 register 25	C1MDATA125			√		Undefined
03FECA22H	CAN1 message data byte 23 register 25	C1MDATA2325				√	Undefined
03FECA22H	CAN1 message data byte 2 register 25	C1MDATA225			√		Undefined
03FECA23H	CAN1 message data byte 3 register 25	C1MDATA325			√		Undefined
03FECA24H	CAN1 message data byte 45 register 25	C1MDATA4525				√	Undefined
03FECA24H	CAN1 message data byte 4 register 25	C1MDATA425			√		Undefined
03FECA25H	CAN1 message data byte 5 register 25	C1MDATA525			√		Undefined
03FECA26H	CAN1 message data byte 67 register 25	C1MDATA6725				√	Undefined
03FECA26H	CAN1 message data byte 6 register 25	C1MDATA625			√		Undefined
03FECA27H	CAN1 message data byte 7 register 25	C1MDATA725			√		Undefined
03FECA28H	CAN1 message data length register 25	C1MDLC25			√		0000xxxxB
03FECA29H	CAN1 message configuration register 25	C1MCONF25			√		Undefined
03FECA2AH	CAN1 message identifier register 25	C1MIDL25				√	Undefined
03FECA2CH		C1MIDH25				√	Undefined
03FECA2EH	CAN1 message control register 25	C1MCTRL25				√	00x00000 000xx000B

Table 21-16. Register Access Types (32/34)

Address	Register Name	Symbol	R/W	Bit Manipulation Units			After Reset
				1 Bit	8 Bits	16 Bits	
03FECA40H	CAN1 message data byte 01 register 26	C1MDATA0126	R/W			√	Undefined
03FECA40H	CAN1 message data byte 0 register 26	C1MDATA026			√		Undefined
03FECA41H	CAN1 message data byte 1 register 26	C1MDATA126			√		Undefined
03FECA42H	CAN1 message data byte 23 register 26	C1MDATA2326				√	Undefined
03FECA42H	CAN1 message data byte 2 register 26	C1MDATA226			√		Undefined
03FECA43H	CAN1 message data byte 3 register 26	C1MDATA326			√		Undefined
03FECA44H	CAN1 message data byte 45 register 26	C1MDATA4526				√	Undefined
03FECA44H	CAN1 message data byte 4 register 26	C1MDATA426			√		Undefined
03FECA45H	CAN1 message data byte 5 register 26	C1MDATA526			√		Undefined
03FECA46H	CAN1 message data byte 67 register 26	C1MDATA6726				√	Undefined
03FECA46H	CAN1 message data byte 6 register 26	C1MDATA626			√		Undefined
03FECA47H	CAN1 message data byte 7 register 26	C1MDATA726			√		Undefined
03FECA48H	CAN1 message data length register 26	C1MDLC26			√		0000xxxxB
03FECA49H	CAN1 message configuration register 26	C1MCONF26			√		Undefined
03FECA4AH	CAN1 message identifier register 26	C1MIDL26				√	Undefined
03FECA4CH		C1MIDH26				√	Undefined
03FECA4EH	CAN1 message control register 26	C1MCTRL26				√	00x00000 000xx000B
03FECA60H	CAN1 message data byte 01 register 27	C1MDATA0127				√	Undefined
03FECA60H	CAN1 message data byte 0 register 27	C1MDATA027			√		Undefined
03FECA61H	CAN1 message data byte 1 register 27	C1MDATA127			√		Undefined
03FECA62H	CAN1 message data byte 23 register 27	C1MDATA2327				√	Undefined
03FECA62H	CAN1 message data byte 2 register 27	C1MDATA227			√		Undefined
03FECA63H	CAN1 message data byte 3 register 27	C1MDATA327			√		Undefined
03FECA64H	CAN1 message data byte 45 register 27	C1MDATA4527				√	Undefined
03FECA64H	CAN1 message data byte 4 register 27	C1MDATA427			√		Undefined
03FECA65H	CAN1 message data byte 5 register 27	C1MDATA527			√		Undefined
03FECA66H	CAN1 message data byte 67 register 27	C1MDATA6727			√	Undefined	
03FECA66H	CAN1 message data byte 6 register 27	C1MDATA627		√		Undefined	
03FECA67H	CAN1 message data byte 7 register 27	C1MDATA727		√		Undefined	
03FECA68H	CAN1 message data length register 27	C1MDLC27		√		0000xxxxB	
03FECA69H	CAN1 message configuration register 27	C1MCONF27		√		Undefined	
03FECA6AH	CAN1 message identifier register 27	C1MIDL27			√	Undefined	
03FECA6CH		C1MIDH27			√	Undefined	
03FECA6EH	CAN1 message control register 27	C1MCTRL27			√	00x00000 000xx000B	

Table 21-16. Register Access Types (33/34)

Address	Register Name	Symbol	R/W	Bit Manipulation Units			After Reset
				1 Bit	8 Bits	16 Bits	
03FECA80H	CAN1 message data byte 01 register 28	C1MDATA0128	R/W			√	Undefined
03FECA80H	CAN1 message data byte 0 register 28	C1MDATA028			√		Undefined
03FECA81H	CAN1 message data byte 1 register 28	C1MDATA128			√		Undefined
03FECA82H	CAN1 message data byte 23 register 28	C1MDATA2328				√	Undefined
03FECA82H	CAN1 message data byte 2 register 28	C1MDATA228			√		Undefined
03FECA83H	CAN1 message data byte 3 register 28	C1MDATA328			√		Undefined
03FECA84H	CAN1 message data byte 45 register 28	C1MDATA4528				√	Undefined
03FECA84H	CAN1 message data byte 4 register 28	C1MDATA428			√		Undefined
03FECA85H	CAN1 message data byte 5 register 28	C1MDATA528			√		Undefined
03FECA86H	CAN1 message data byte 67 register 28	C1MDATA6728				√	Undefined
03FECA86H	CAN1 message data byte 6 register 28	C1MDATA628			√		Undefined
03FECA87H	CAN1 message data byte 7 register 28	C1MDATA728			√		Undefined
03FECA88H	CAN1 message data length register 28	C1MDLC28			√		0000xxxxB
03FECA89H	CAN1 message configuration register 28	C1MCONF28			√		Undefined
03FECA8AH	CAN1 message identifier register 28	C1MIDL28				√	Undefined
03FECA8CH		C1MIDH28				√	Undefined
03FECA8EH	CAN1 message control register 28	C1MCTRL28				√	00x00000 000xx000B
03FECAA0H	CAN1 message data byte 01 register 29	C1MDATA0129				√	Undefined
03FECAA0H	CAN1 message data byte 0 register 29	C1MDATA029			√		Undefined
03FECAA1H	CAN1 message data byte 1 register 29	C1MDATA129			√		Undefined
03FECAA2H	CAN1 message data byte 23 register 29	C1MDATA2329				√	Undefined
03FECAA2H	CAN1 message data byte 2 register 29	C1MDATA229			√		Undefined
03FECAA3H	CAN1 message data byte 3 register 29	C1MDATA329			√		Undefined
03FECAA4H	CAN1 message data byte 45 register 29	C1MDATA4529				√	Undefined
03FECAA4H	CAN1 message data byte 4 register 29	C1MDATA429			√		Undefined
03FECAA5H	CAN1 message data byte 5 register 29	C1MDATA529			√		Undefined
03FECAA6H	CAN1 message data byte 67 register 29	C1MDATA6729				√	Undefined
03FECAA6H	CAN1 message data byte 6 register 29	C1MDATA629			√		Undefined
03FECAA7H	CAN1 message data byte 7 register 29	C1MDATA729			√		Undefined
03FECAA8H	CAN1 message data length register 29	C1MDLC29			√		0000xxxxB
03FECAA9H	CAN1 message configuration register 29	C1MCONF29			√		Undefined
03FECAA AH	CAN1 message identifier register 29	C1MIDL29				√	Undefined
03FECAA CH		C1MIDH29				√	Undefined
03FECAA EH	CAN1 message control register 29	C1MCTRL29			√	00x00000 000xx000B	



Table 21-16. Register Access Types (34/34)

Address	Register Name	Symbol	R/W	Bit Manipulation Units			After Reset
				1 Bit	8 Bits	16 Bits	
03FECAC0H	CAN1 message data byte 01 register 30	C1MDATA0130	R/W			√	Undefined
03FECAC0H	CAN1 message data byte 0 register 30	C1MDATA030			√		Undefined
03FECAC1H	CAN1 message data byte 1 register 30	C1MDATA130			√		Undefined
03FECAC2H	CAN1 message data byte 23 register 30	C1MDATA2330				√	Undefined
03FECAC2H	CAN1 message data byte 2 register 30	C1MDATA230			√		Undefined
03FECAC3H	CAN1 message data byte 3 register 30	C1MDATA330			√		Undefined
03FECAC4H	CAN1 message data byte 45 register 30	C1MDATA4530				√	Undefined
03FECAC4H	CAN1 message data byte 4 register 30	C1MDATA430			√		Undefined
03FECAC5H	CAN1 message data byte 5 register 30	C1MDATA530			√		Undefined
03FECAC6H	CAN1 message data byte 67 register 30	C1MDATA6730				√	Undefined
03FECAC6H	CAN1 message data byte 6 register 30	C1MDATA630			√		Undefined
03FECAC7H	CAN1 message data byte 7 register 30	C1MDATA730			√		Undefined
03FECAC8H	CAN1 message data length register 30	C1MDLC30			√		0000xxxxB
03FECAC9H	CAN1 message configuration register 30	C1MCONF30			√		Undefined
03FECACAH	CAN1 message identifier register 30	C1MIDL30				√	Undefined
03FECACCH		C1MIDH30				√	Undefined
03FECACEH	CAN1 message control register 30	C1MCTRL30				√	00x00000 000xx000B
03FECAE0H	CAN1 message data byte 01 register 31	C1MDATA0131				√	Undefined
03FECAE0H	CAN1 message data byte 0 register 31	C1MDATA031			√		Undefined
03FECAE1H	CAN1 message data byte 1 register 31	C1MDATA131			√		Undefined
03FECAE2H	CAN1 message data byte 23 register 31	C1MDATA2331				√	Undefined
03FECAE2H	CAN1 message data byte 2 register 31	C1MDATA231			√		Undefined
03FECAE3H	CAN1 message data byte 3 register 31	C1MDATA331			√		Undefined
03FECAE4H	CAN1 message data byte 45 register 31	C1MDATA4531				√	Undefined
03FECAE4H	CAN1 message data byte 4 register 31	C1MDATA431			√		Undefined
03FECAE5H	CAN1 message data byte 5 register 31	C1MDATA531			√		Undefined
03FECAE6H	CAN1 message data byte 67 register 31	C1MDATA6731				√	Undefined
03FECAE6H	CAN1 message data byte 6 register 31	C1MDATA631			√		Undefined
03FECAE7H	CAN1 message data byte 7 register 31	C1MDATA731			√		Undefined
03FECAE8H	CAN1 message data length register 31	C1MDLC31			√		0000xxxxB
03FECAE9H	CAN1 message configuration register 31	C1MCONF31		√		Undefined	
03FECAEAH	CAN1 message identifier register 31	C1MIDL31			√	Undefined	
03FECAECH		C1MIDH31			√	Undefined	
03FECAEEH	CAN1 message control register 31	C1MCTRL31			√	00x00000 000xx000B	

## 21.5.3 Register bit configuration

Table 21-17. CAN Global Register Bit Configuration

Address	Symbol	Bit 7/15	Bit 6/14	Bit 5/13	Bit 4/12	Bit 3/11	Bit 2/10	Bit 1/9	Bit 0/8
03FExx00H	CnGMCTRL (W)	0	0	0	0	0	0	0	Clear GOM
03FExx01H		0	0	0	0	0	0	Set EFSD	Set GOM
03FExx00H	CnGMCTRL (R)	0	0	0	0	0	0	EFSD	GOM
03FExx01H		MBON	0	0	0	0	0	0	0
03FExx02H	CnGMCS	0	0	0	0	CCP3	CCP2	CCP1	CCP0
03FExx06H	CnGMABT (W)	0	0	0	0	0	0	0	Clear ABTTRG
03FExx07H		0	0	0	0	0	0	Set ABTCLR	Set ABTTRG
03FExx06H	CnGMABT (R)	0	0	0	0	0	0	ABTCLR	ABTTRG
03FExx07H		0	0	0	0	0	0	0	0
03FExx08H	CnGMABTD	0	0	0	0	ABTD3	ABTD2	ABTD1	ABTD0

**Remark** n = 0, 1  
 When n = 0, xx = C0  
 When n = 1, xx = C6

**Table 21-18. CAN Module Register Bit Configuration (1/2)**

Address	Symbol	Bit 7/15	Bit 6/14	Bit 5/13	Bit 4/12	Bit 3/11	Bit 2/10	Bit 1/9	Bit 0/8
03FExx40H	CnMASK1L	CMID7 to CMID0							
03FExx41H		CMID15 to CMID8							
03FExx42H	CnMASK1H	CMID23 to CMID16							
03FExx43H		0	0	0	CMID28 to CMID24				
03FExx44H	CnMASK2L	CMID7 to CMID0							
03FExx45H		CMID15 to CMID8							
03FExx46H	CnMASK2H	CMID23 to CMID16							
03FExx47H		0	0	0	CMID28 to CMID24				
03FExx48H	CnMASK3L	CMID7 to CMID0							
03FExx49H		CMID15 to CMID8							
03FExx4AH	CnMASK3H	CMID23 to CMID16							
03FExx4BH		0	0	0	CMID28 to CMID24				
03FExx4CH	CnMASK4L	CMID7 to CMID0							
03FExx4DH		CMID15 to CMID8							
03FExx4EH	CnMASK4H	CMID23 to CMID16							
03FExx4FH		0	0	0	CMID28 to CMID24				
03FExx50H	CnCTRL (W)	0	Clear AL	Clear VALID	Clear PSMODE1	Clear PSMODE0	Clear OPMODE2	Clear OPMODE1	Clear OPMODE0
03FExx51H		Set CCERC	Set AL	0	Set PSMODE1	Set PSMODE0	Set OPMODE2	Set OPMODE1	Set OPMODE0
03FExx50H	CnCTRL (R)	CCERC	AL	VALID	PS MODE1	PS MODE0	OP MODE2	OP MODE1	OP MODE0
03FExx51H		0	0	0	0	0	0	RSTAT	TSTAT
03FExx52H	CnLEC (W)	0	0	0	0	0	0	0	0
03FExx52H	CnLEC (R)	0	0	0	0	0	LEC2	LEC1	LEC0
03FExx53H	CnINFO	0	0	0	BOFF	TECS1	TECS0	RECS1	RECS0
03FExx54H	CnERC	TEC7 to TEC0							
03FExx55H		REC7 to REC0							
03FExx56H	CnIE (W)	0	0	Clear CIE5	Clear CIE4	Clear CIE3	Clear CIE2	Clear CIE1	Clear CIE0
03FExx57H		0	0	Set CIE5	Set CIE4	Set CIE3	Set CIE2	Set CIE1	Set CIE0
03FExx56H	CnIE (R)	0	0	CIE5	CIE4	CIE3	CIE2	CIE1	CIE0
03FExx57H		0	0	0	0	0	0	0	0
03FExx58H	CnINTS (W)	0	0	Clear CINTS5	Clear CINTS4	Clear CINTS3	Clear CINTS2	Clear CINTS1	Clear CINTS0
03FExx59H		0	0	0	0	0	0	0	0
03FExx58H	CnINTS (R)	0	0	CINTS5	CINTS4	CINTS3	CINTS2	CINTS1	CINTS0
03FExx59H		0	0	0	0	0	0	0	0

**Remark** n = 0, 1  
 When n = 0, xx = C0  
 When n = 1, xx = C6

**Table 21-18. CAN Module Register Bit Configuration (2/2)**

Address	Symbol	Bit 7/15	Bit 6/14	Bit 5/13	Bit 4/12	Bit 3/11	Bit 2/10	Bit 1/9	Bit 0/8
03FExx5AH	CnBRP	TQPRS7 to TQPRS0							
03FExx5CH	CnBTR	0	0	0	0	TSEG13 to TSEG10			
03FExx5DH		0	0	SJW1, SJW0		0	TSEG22 to TSEG20		
03FExx5EH	CnLIPT	LIPT7 to LIPT0							
03FExx60H	CnRGPT (W)	0	0	0	0	0	0	0	Clear ROVF
03FExx61H		0	0	0	0	0	0	0	0
03FExx60H	CnRGPT (R)	0	0	0	0	0	0	RHPM	ROVF
03FExx61H		RGPT7 to RGPT0							
03FExx62H	CnLOPT	LOPT7 to LOPT0							
03FExx64H	CnTGPT (W)	0	0	0	0	0	0	0	Clear TOVF
03FExx65H		0	0	0	0	0	0	0	0
03FExx64H	CnTGPT (R)	0	0	0	0	0	0	THPM	TOVF
03FExx65H		TGPT7 to TGPT0							
03FExx66H	CnTS (W)	0	0	0	0	0	Clear TSLOCK	Clear TSSEL	Clear TSEN
03FExx67H		0	0	0	0	0	Set TSLOCK	Set TSSEL	Set TSEN
03FExx66H	CnTS (R)	0	0	0	0	0	TSLOCK	TSSEL	TSEN
03FExx67H		0	0	0	0	0	0	0	0
03FExx68H to 03FExxFFH	–	Access prohibited (reserved for future use)							

**Remark** n = 0, 1  
 When n = 0, xx = C0  
 When n = 1, xx = C6

Table 21-19. Message Buffer Register Bit Configuration

Address	Symbol	Bit 7/15	Bit 6/14	Bit 5/13	Bit 4/12	Bit 3/11	Bit 2/10	Bit 1/9	Bit 0/8	
03FECxx0H	CnMDATA01m	Message data (byte 0)								
03FECxx1H		Message data (byte 1)								
03FECxx0H	CnMDATA0m	Message data (byte 0)								
03FECxx1H	CnMDATA1m	Message data (byte 1)								
03FECxx2H	CnMDATA23m	Message data (byte 2)								
03FECxx3H		Message data (byte 3)								
03FECxx2H	CnMDATA2m	Message data (byte 2)								
03FECxx3H	CnMDATA3m	Message data (byte 3)								
03FECxx4H	CnMDATA45m	Message data (byte 4)								
03FECxx5H		Message data (byte 5)								
03FECxx4H	CnMDATA4m	Message data (byte 4)								
03FECxx5H	CnMDATA5m	Message data (byte 5)								
03FECxx6H	CnMDATA67m	Message data (byte 6)								
03FECxx7H		Message data (byte 7)								
03FECxx6H	CnMDATA6m	Message data (byte 6)								
03FECxx7H	CnMDATA7m	Message data (byte 7)								
03FECxx8H	CnMDLcM	0				MDLC3	MDLC2	MDLC1	MDLC0	
03FECxx9H	CnMCONFm	OWS	RTR	MT2	MT1	MT0	0	0	MA0	
03FECxxAH	CnMIDLm	ID7	ID6	ID5	ID4	ID3	ID2	ID1	ID0	
03FECxxBH		ID15	ID14	ID13	ID12	ID11	ID10	ID9	ID8	
03FECxxCH	CnMIDHm	ID23	ID22	ID21	ID20	ID19	ID18	ID17	ID16	
03FECxxDH		IDE	0	0	ID28	ID27	ID26	ID25	ID24	
03FECxxEH	CnMCTRLm (W)	0	0	0	Clear MOW	Clear IE	Clear DN	Clear TRQ	Clear RDY	
03FECxxFH		0	0	0	0	Set IE	0	Set TRQ	Set RDY	
03FECxxEH	CnMCTRLm (R)	0	0	0	MOW	IE	DN	TRQ	RDY	
03FECxxFH		0	0	MUC	0	0	0	0	0	
03FECxx0 to 03FECxxFH	–	Access prohibited (reserved for future use)								

**Remark** n = 0, 1

m = 00 to 31

When n = 0, xx = 10, 12, 14, 16, 18, 1A, 1C, 1E, 20, 22, 24, 26, 28, 2A, 2C, 2E, 30, 32, 34, 36, 38, 3A, 3C, 3E, 40, 42, 44, 46, 48, 4A, 4C, 4E

When n = 1, xx = 70, 72, 74, 76, 78, 7A, 7C, 7E, 80, 82, 84, 86, 88, 8A, 8C, 8E, 90, 92, 94, 96, 98, 9A, 9C, 9E, A0, A2, A4, A6, A8, AA, AC, AE

## 21.6 Registers

**Caution** Accessing the CAN controller registers is prohibited in the following statuses. For details, refer to 3.4.9 (2) Accessing specific on-chip peripheral I/O registers.

- When the CPU operates with the subclock and the main clock oscillation is stopped
- When the CPU operates with the internal oscillation clock

**Remark** n = 0, 1  
m = 00 to 31

**(1) CANn global control register (CnGMCTRL)**

The CnGMCTRL register is used to control the operation of the CAN module.

(1/2)

After reset: 0000H R/W Address: C0GMCTRL 03FEC000H, C1GMCTRL 03FEC600H

(a) Read

	15	14	13	12	11	10	9	8
CnGMCTRL	MBON	0	0	0	0	0	0	0
	7	6	5	4	3	2	1	0
	0	0	0	0	0	0	EFSD	GOM

(b) Write

	15	14	13	12	11	10	9	8
CnGMCTRL	0	0	0	0	0	0	Set EFSD	Set GOM
	7	6	5	4	3	2	1	0
	0	0	0	0	0	0	0	Clear GOM

(a) Read

MBON	Bit enabling access to message buffer register, transmit/receive history registers
0	Write access and read access to the message buffer register and the transmit/receive history list registers is disabled.
1	Write access and read access to the message buffer register and the transmit/receive history list registers is enabled.

**Cautions 1.** While the MBON bit is cleared (to 0), software access to the message buffers (CnMDATA0m, CnMDATA1m, CnMDATA01m, CnMDATA2m, CnMDATA3m, CnMDATA23m, CnMDATA4m, CnMDATA5m, CnMDATA45m, CnMDATA6m, CnMDATA7m, CnMDATA67m, CnMDLc, CnMCONFm, CnMIDLm, CnMIDHm, and CnMCTRLm), or registers related to transmit history or receive history (CnLLOPT, CnTGPT, CnLIPT, and CnRGPT) is disabled.

**2.** This bit is read-only. Even if 1 is written to the MBON bit while it is 0, the value of the MBON bit does not change, and access to the message buffer registers, or registers related to transmit history or receive history remains disabled.

**Remark** When the CAN sleep mode/CAN stop mode is entered, or when the GOM bit is cleared to 0, the MBON bit is cleared to 0. When the CAN sleep mode/CAN stop mode is released, or when the GOM bit is set to 1, the MBON bit is set to 1.

EFSD	Bit enabling forced shut down
0	Forced shut down by GOM bit = 0 disabled.
1	Forced shut down by GOM bit = 0 enabled.

**Caution** To request forced shut down, clear the GOM bit to 0 immediately after the EFSD bit has been set to 1. If access to another register (including reading the CnGMCTRL register) is executed by software (interrupts including NMI) or DMA without clearing the GOM bit immediately after the EFSD bit has been set to 1, the EFSD bit is forcibly cleared to 0, and the forced shut down request is invalid.

GOM	Global operation mode bit
0	CAN module is disabled from operating.
1	CAN module is enabled to operate.

**Caution** The GOM bit is cleared to 0 only in the initialization mode or immediately after the EFSD bit is set to 1.

(b) Write

Set EFSD	EFSD bit setting
0	No change in EFSD bit.
1	EFSD bit set to 1.

Set GOM	Clear GOM	GOM bit setting
0	1	GOM bit cleared to 0.
1	0	GOM bit set to 1.
Other than above		No change in GOM bit.

**Caution** Be sure to set the GOM bit and EFSD bit separately.



**(2) CANn global clock selection register (CnGMCS)**

The CnGMCS register is used to select the CAN module system clock.

After reset: 0FH      R/W      Address: C0GMCS 03FEC002H, C1GMCS 03FEC602H

	7	6	5	4	3	2	1	0
CnGMCS	0	0	0	0	CCP3	CCP2	CCP1	CCP0

CCP3	CCP2	CCP1	CCP0	CAN module system clock ( $f_{CANMOD}$ )
0	0	0	0	$f_{CAN/1}$
0	0	0	1	$f_{CAN/2}$
0	0	1	0	$f_{CAN/3}$
0	0	1	1	$f_{CAN/4}$
0	1	0	0	$f_{CAN/5}$
0	1	0	1	$f_{CAN/6}$
0	1	1	0	$f_{CAN/7}$
0	1	1	1	$f_{CAN/8}$
1	0	0	0	$f_{CAN/9}$
1	0	0	1	$f_{CAN/10}$
1	0	1	0	$f_{CAN/11}$
1	0	1	1	$f_{CAN/12}$
1	1	0	0	$f_{CAN/13}$
1	1	0	1	$f_{CAN/14}$
1	1	1	0	$f_{CAN/15}$
1	1	1	1	$f_{CAN/16}$ (Default value)

**Remark**  $f_{CAN}$ : CAN clock frequency

In clock mode 1,  $f_{CAN} = f_{XX}$

In clock mode 2,  $f_{CAN} = f_{XMPLL}$  (29.28 to 32 MHz)

In clock mode 3,  $f_{CAN} = f_{XMPLL}$  (29.28 to 32 MHz)

In clock mode 4,  $f_{CAN} = f_{XMPLL}/2$  (20.88 to 24 MHz)

$f_{XX}$ : Main clock frequency

$f_{XMPLL}$ : PLL output clock frequency for peripheral clocks

**(3) CANn global automatic block transmission control register (CnGMABT)**

The CnGMABT register is used to control the automatic block transmission (ABT) operation.

(1/2)

After reset: 0000H R/W Address: C0GMABT 03FEC006H, C1GMABT 03FEC606H

(a) Read

	15	14	13	12	11	10	9	8
CnGMABT	0	0	0	0	0	0	0	0
	7	6	5	4	3	2	1	0
	0	0	0	0	0	0	ABTCLR	ABTTRG

(b) Write

	15	14	13	12	11	10	9	8
CnGMABT	0	0	0	0	0	0	Set ABTCLR	Set ABTTRG
	7	6	5	4	3	2	1	0
	0	0	0	0	0	0	0	Clear ABTTRG

**Caution** Before changing the normal operation mode with ABT to the initialization mode, be sure to set the CnGMABT register to the default value (0000H). After setting, confirm that the CnGMABT register is initialized to 0000H.

(a) Read

ABTCLR	Automatic block transmission engine clear status bit
0	Clearing the automatic transmission engine is completed.
1	The automatic transmission engine is being cleared.

- Remarks**
1. Set the ABTCLR bit to 1 while the ABTTRG bit is cleared to 0.  
The operation is not guaranteed if the ABTCLR bit is set to 1 while the ABTTRG bit is set to 1.
  2. When the automatic block transmission engine is cleared by setting the ABTCLR bit to 1, the ABTCLR bit is automatically cleared to 0 as soon as the requested clearing processing is complete.

ABTTRG	Automatic block transmission status bit
0	Automatic block transmission is stopped.
1	Automatic block transmission is under execution.

- Cautions**
1. Do not set the ABTTRG bit to 1 in the initialization mode. If the ABTTRG bit is set to 1 in the initialization mode, the operation is not guaranteed after the CAN module has entered the normal operation mode with ABT.
  2. Do not set the ABTTRG bit to 1 while the CnCTRL.TSTAT bit is set to 1. Directly confirm that the TSTAT bit = 0 before setting the ABTTRG bit to 1.

(b) Write

Set ABTCLR	Automatic block transmission engine clear request bit
0	The automatic block transmission engine is in idle status or under operation.
1	Request to clear the automatic block transmission engine. After the automatic block transmission engine has been cleared, automatic block transmission is started from message buffer 0 by setting the ABTTRG bit to 1.

Set ABTTRG	Clear ABTTRG	Automatic block transmission start bit
0	1	Request to stop automatic block transmission.
1	0	Request to start automatic block transmission.
Other than above		No change in ABTTRG bit.

**Caution** Even if the ABTTRG bit is set (1), transmission is not immediately executed, depending on the situation such as when a message is received from another node or when a message other than the ABT message (message buffers 8 to 31) is transmitted. Even if the ABTTRG bit is cleared (0), transmission is not terminated midway. If transmission is under execution, it is continued until completed (regardless of whether transmission is successful or fails).

**(4) CANn global automatic block transmission delay register (CnGMABTD)**

The CnGMABTD register is used to set the interval at which the data of the message buffer assigned to ABT is to be transmitted in the normal operation mode with ABT.

After reset: 00H      R/W      Address: C0GMABTD 03FEC008H, C1GMABTD 03FEC608H

	7	6	5	4	3	2	1	0
CnGMABTD	0	0	0	0	ABTD3	ABTD2	ABTD1	ABTD0

ABTD3	ABTD2	ABTD1	ABTD0	Data frame interval during automatic block transmission (Unit: Data bit time (DBT))
0	0	0	0	0 DBT (default value)
0	0	0	1	2 <sup>5</sup> DBT
0	0	1	0	2 <sup>6</sup> DBT
0	0	1	1	2 <sup>7</sup> DBT
0	1	0	0	2 <sup>8</sup> DBT
0	1	0	1	2 <sup>9</sup> DBT
0	1	1	0	2 <sup>10</sup> DBT
0	1	1	1	2 <sup>11</sup> DBT
1	0	0	0	2 <sup>12</sup> DBT
Other than above				Setting prohibited

- Cautions**
1. Do not change the contents of the CnGMABTD register while the ABTTRG bit is set to 1.
  2. The timing at which the ABT message is actually transmitted onto the CAN bus differs depending on the status of transmission from the other station or how a request to transmit a message other than an ABT message (message buffers 8 to 31) is made.
  3. Be sure to set bits 4 to 7 to "0".

**(5) CANn module mask control register (CnMASKaL, CnMASKaH) (a = 1, 2, 3, or 4)**

The CnMASKaL and CnMASKaH registers are used to extend the number of receivable messages in the same message buffer by masking part of the identifier (ID) of a message and invalidating the ID comparison of the masked part.

(1/2)

• CANn module mask 1 register (CnMASK1L, CnMASK1H)

After reset: Undefined      R/W      Address: C0MASK1L 03FEC040H, C1MASK1L 03FEC640H,  
C0MASK1H 03FEC042H, C1MASK1H 03FEC642H

	15	14	13	12	11	10	9	8
CnMASK1L	CMID15	CMID14	CMID13	CMID12	CMID11	CMID10	CMID9	CMID8
	7	6	5	4	3	2	1	0
	CMID7	CMID6	CMID5	CMID4	CMID3	CMID2	CMID1	CMID0
	15	14	13	12	11	10	9	8
CnMASK1H	0	0	0	CMID28	CMID27	CMID26	CMID25	CMID24
	7	6	5	4	3	2	1	0
	CMID23	CMID22	CMID21	CMID20	CMID19	CMID18	CMID17	CMID16

• CANn module mask 2 register (CnMASK2L, CnMASK2H)

After reset: Undefined      R/W      Address: C0MASK2L 03FEC044H, C1MASK2L 03FEC644H,  
C0MASK2H 03FEC046H, C1MASK2H 03FEC646H

	15	14	13	12	11	10	9	8
CnMASK2L	CMID15	CMID14	CMID13	CMID12	CMID11	CMID10	CMID9	CMID8
	7	6	5	4	3	2	1	0
	CMID7	CMID6	CMID5	CMID4	CMID3	CMID2	CMID1	CMID0
	15	14	13	12	11	10	9	8
CnMASK2H	0	0	0	CMID28	CMID27	CMID26	CMID25	CMID24
	7	6	5	4	3	2	1	0
	CMID23	CMID22	CMID21	CMID20	CMID19	CMID18	CMID17	CMID16

• CANn module mask 3 register (CnMASK3L, CnMASK3H)

After reset: Undefined R/W Address: C0MASK3L 03FEC048H, C1MASK3L 03FEC648H,  
C0MASK3H 03FEC04AH, C1MASK3H 03FEC64AH

	15	14	13	12	11	10	9	8
CnMASK3L	CMID15	CMID14	CMID13	CMID12	CMID11	CMID10	CMID9	CMID8
	7	6	5	4	3	2	1	0
	CMID7	CMID6	CMID5	CMID4	CMID3	CMID2	CMID1	CMID0
	15	14	13	12	11	10	9	8
CnMASK3H	0	0	0	CMID28	CMID27	CMID26	CMID25	CMID24
	7	6	5	4	3	2	1	0
	CMID23	CMID22	CMID21	CMID20	CMID19	CMID18	CMID17	CMID16

• CANn module mask 4 register (CnMASK4L, CnMASK4H)

After reset: Undefined R/W Address: C0MASK4L 03FEC04CH, C1MASK4L 03FEC64CH,  
C0MASK4H 03FEC04EH, C1MASK4H 03FEC64EH

	15	14	13	12	11	10	9	8
CnMASK4L	CMID15	CMID14	CMID13	CMID12	CMID11	CMID10	CMID9	CMID8
	7	6	5	4	3	2	1	0
	CMID7	CMID6	CMID5	CMID4	CMID3	CMID2	CMID1	CMID0
	15	14	13	12	11	10	9	8
CnMASK4H	0	0	0	CMID28	CMID27	CMID26	CMID25	CMID24
	7	6	5	4	3	2	1	0
	CMID23	CMID22	CMID21	CMID20	CMID19	CMID18	CMID17	CMID16

CMID28 to CMID0	Mask pattern setting of ID bit
0	The ID bits of the message buffer set by the CMID28 to CMID0 bits are compared with the ID bits of the received message frame.
1	The ID bits of the message buffer set by the CMID28 to CMID0 bits are not compared with the ID bits of the received message frame (they are masked).

**Caution** Be sure to set bits 13 to 15 of the CnMASKaH register to 0.

**Remark** Masking is always defined by an ID length of 29 bits. If a mask is assigned to a message with a standard ID, the CMID17 to CMID0 bits are ignored. Therefore, only the CMID28 to CMID18 bits of the received ID are masked. The same mask can be used for both the standard and extended IDs.

**(6) CANn module control register (CnCTRL)**

The CnCTRL register is used to control the operation mode of the CAN module.

(1/4)

After reset: 0000H R/W Address: C0CTRL 03FEC050H, C1CTRL 03FFEC650H

(a) Read

	15	14	13	12	11	10	9	8
CnCTRL	0	0	0	0	0	0	RSTAT	TSTAT
	7	6	5	4	3	2	1	0
	CCERC	AL	VALID	PSMODE	PSMODE	OPMODE	OPMODE	OPMODE
				1	0	2	1	0

(b) Write

	15	14	13	12	11	10	9	8
CnCTRL	Set CCERC	Set AL	0	Set PSMODE	Set PSMODE	Set OPMODE	Set OPMODE	Set OPMODE
				1	0	2	1	0
	7	6	5	4	3	2	1	0
	0	Clear AL	Clear VALID	Clear PSMODE	Clear PSMODE	Clear OPMODE	Clear OPMODE	Clear OPMODE
				1	0	2	1	0

(a) Read

RSTAT	Reception status bit
0	Reception is stopped.
1	Reception is in progress.

- Remark**
- The RSTAT bit is set to 1 under the following conditions (timing)
    - The SOF bit of a receive frame is detected
    - On occurrence of arbitration loss during a transmit frame
  - The RSTAT bit is cleared to 0 under the following conditions (timing)
    - When a recessive level is detected at the second bit of the interframe space
    - On transition to the initialization mode at the first bit of the interframe space

TSTAT	Transmission status bit
0	Transmission is stopped.
1	Transmission is in progress.

- Remark**
- The TSTAT bit is set to 1 under the following conditions (timing)
    - The SOF bit of a transmit frame is detected
  - The TSTAT bit is cleared to 0 under the following conditions (timing)
    - During transition to bus-off status
    - On occurrence of arbitration loss in transmit frame
    - On detection of recessive level at the second bit of the interframe space
    - On transition to the initialization mode at the first bit of the interframe space

CCERC	Error counter clear bit
0	The CnERC and CnINFO registers are not cleared in the initialization mode.
1	The CnERC and CnINFO registers are cleared in the initialization mode.

- Remarks**
1. The CCERC bit is used to clear the CnERC and CnINFO registers for re-initialization or forced recovery from the bus-off status. This bit can be set to 1 only in the initialization mode.
  2. When the CnERC and CnINFO registers have been cleared, the CCERC bit is also cleared to 0 automatically.
  3. The CCERC bit can be set to 1 at the same time as a request to change the initialization mode to an operation mode is made.
  4. If the CCERC bit is set to 1 immediately after the INIT mode is entered in the self test mode, the receive data may be corrupted.

AL	Bit to set operation in case of arbitration loss
0	Re-transmission is not executed in case of an arbitration loss in the single-shot mode.
1	Re-transmission is executed in case of an arbitration loss in the single-shot mode.

**Remark** The AL bit is valid only in the single-shot mode.

VALID	Valid receive message frame detection bit
0	A valid message frame has not been received since the VALID bit was last cleared to 0.
1	A valid message frame has been received since the VALID bit was last cleared to 0.

- Remarks**
1. Detection of a valid receive message frame is not dependent upon the existence or non-existence of the storage in the receive message buffer (data frame) or transmit message buffer (remote frame).
  2. Clear the VALID bit (0) before changing the initialization mode to an operation mode.
  3. If only two CAN nodes are connected to the CAN bus with one transmitting a message frame in the normal mode and the other in the receive-only mode, since no ACK is generated in the receive-only mode, the VALID bit is not set to 1 before the transmitting node enters the error passive status.
  4. To clear the VALID bit, set the Clear VALID bit to 1 first and confirm that the VALID bit is cleared. If it is not cleared, perform clearing processing again.



PSMODE1	PSMODE0	Power save mode
0	0	No power save mode is selected.
0	1	CAN sleep mode
1	0	Setting prohibited
1	1	CAN stop mode

- Cautions**
1. Transition to and from the CAN stop mode must be made via CAN sleep mode. A request for direct transition to and from the CAN stop mode is ignored.
  2. After releasing the power save mode, the CnGMCTRL.MBON flag must be checked before accessing the message buffer again.
  3. A request for transition to the CAN sleep mode is held pending until it is canceled by software or until the CAN bus enters the bus idle state. The software can check transition to the CAN sleep mode by reading the PSMODE0 and PSMODE1 bits.

OPMODE2	OPMODE1	OPMODE0	Operation mode
0	0	0	No operation mode is selected (CAN module is in the initialization mode).
0	0	1	Normal operation mode
0	1	0	Normal operation mode with automatic block transmission function (normal operation mode with ABT)
0	1	1	Receive-only mode
1	0	0	Single-shot mode
1	0	1	Self-test mode
Other than above			Setting prohibited

**Caution** It may take time to change the mode to the initialization mode or power save mode. Therefore, be sure to check if the mode has been successfully changed, by reading the register value before executing the processing.

**Remark** The OPMODE0 to OPMODE2 bits are read-only in the CAN sleep mode or CAN stop mode.

(b) Write

Set CCERC	Setting of CCERC bit
1	CCERC bit is set to 1.
Other than above	CCERC bit is not changed.

Set AL	Clear AL	Setting of AL bit
0	1	AL bit is cleared to 0.
1	0	AL bit is set to 1.
Other than above		AL bit is not changed.

Clear VALID	Setting of VALID bit
0	VALID bit is not changed.
1	VALID bit is cleared to 0.

Set PSMODE0	Clear PSMODE0	Setting of PSMODE0 bit
0	1	PSMODE0 bit is cleared to 0.
1	0	PSMODE bit is set to 1.
Other than above		PSMODE0 bit is not changed.

Set PSMODE1	Clear PSMODE1	Setting of PSMODE1 bit
0	1	PSMODE1 bit is cleared to 0.
1	0	PSMODE1 bit is set to 1.
Other than above		PSMODE1 bit is not changed.

Set OPMODE0	Clear OPMODE0	Setting of OPMODE0 bit
0	1	OPMODE0 bit is cleared to 0.
1	0	OPMODE0 bit is set to 1.
Other than above		OPMODE0 bit is not changed.

Set OPMODE1	Clear OPMODE1	Setting of OPMODE1 bit
0	1	OPMODE1 bit is cleared to 0.
1	0	OPMODE1 bit is set to 1.
Other than above		OPMODE1 bit is not changed.

Set OPMODE2	Clear OPMODE2	Setting of OPMODE2 bit
0	1	OPMODE2 bit is cleared to 0.
1	0	OPMODE2 bit is set to 1.
Other than above		OPMODE2 bit is not changed.

**(7) CANn module last error information register (CnLEC)**

The CnLEC register provides the error information of the CAN protocol.

After reset: 00H      R/W      Address: C0LEC 03FEC052H, C1LEC 03FEC652H

	7	6	5	4	3	2	1	0
CnLEC	0	0	0	0	0	LEC2	LEC1	LEC0

LEC2	LEC1	LEC0	Last CAN protocol error information
0	0	0	No error
0	0	1	Stuff error
0	1	0	Form error
0	1	1	ACK error
1	0	0	Bit error. (The CAN module tried to transmit a recessive-level bit as part of a transmit message (except the arbitration field), but the value on the CAN bus is a dominant-level bit.)
1	0	1	Bit error. (The CAN module tried to transmit a dominant-level bit as part of a transmit message, ACK bit, error frame, or overload frame, but the value on the CAN bus is a recessive-level bit.)
1	1	0	CRC error
1	1	1	Undefined

**Caution** Be sure to set bits 3 to 7 to “0”.

- Remarks**
1. The contents of the CnLEC register are not cleared when the CAN module changes from an operation mode to the initialization mode.
  2. If an attempt is made to write a value other than 00H to the CnLEC register by software, the access is ignored.

**(8) CANn module information register (CnINFO)**

The CnINFO register indicates the status of the CAN module.

After reset: 00H R Address: C0INFO 03FEC053H, C1INFO 03FEC653H

	7	6	5	4	3	2	1	0
CnINFO	0	0	0	BOFF	TECS1	TECS0	RECS1	RECS0

BOFF	Bus-off status bit
0	Not bus-off status (transmit error counter $\leq$ 255). (The value of the transmit counter is less than 256.)
1	Bus-off status (transmit error counter $>$ 255). (The value of the transmit error counter is 256 or more.)

TECS1	TECS0	Transmission error counter status bit
0	0	The value of the transmission error counter is less than that of the warning level ( $<$ 96).
0	1	The value of the transmission error counter is in the range of the warning level (96 to 127).
1	0	Undefined
1	1	The value of the transmission error counter is in the range of the error passive or bus-off status ( $\geq$ 128).

RECS1	RECS0	Reception error counter status bit
0	0	The value of the reception error counter is less than that of the warning level ( $<$ 96).
0	1	The value of the reception error counter is in the range of the warning level (96 to 127).
1	0	Undefined
1	1	The value of the reception error counter is in the error passive range ( $\geq$ 128).

**Caution** Be sure to set bits 5 to 7 to “0”.

**(9) CANn module error counter register (CnERC)**

The CnERC register indicates the count value of the transmission/reception error counter.

After reset: 0000H R Address: C0ERC 03FEC054H, C1ERC 03FEC654H

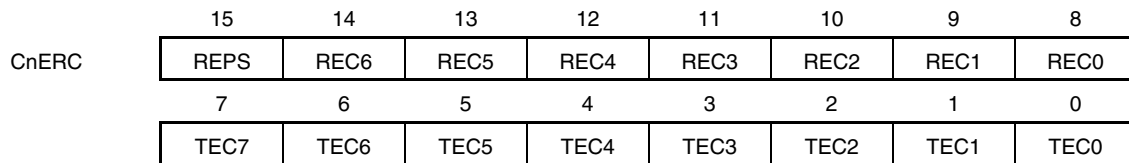

REPS	Reception error passive status bit
0	The value of the reception error counter is not error passive (< 128)
1	The value of the reception error counter is in the error passive range (≥ 128)

REC6 to REC0	Reception error counter bit
0 to 127	Number of reception errors. These bits reflect the status of the reception error counter. The number of errors is defined by the CAN protocol.

**Remark** The REC6 to REC0 bits of the reception error counter are invalid in the reception error passive status (CnINFO.RECS1, CnINFO.RECS0 bit = 11B).

TEC7 to TEC0	Transmission error counter bit
0 to 255	Number of transmission errors. These bits reflect the status of the transmission error counter. The number of errors is defined by the CAN protocol.

**Remark** The TEC7 to TEC0 bits of the transmission error counter are invalid in the bus-off status (CnINFO.BOFF bit = 1).

**(10) CANn module interrupt enable register (CnIE)**

The CnIE register is used to enable or disable the interrupts of the CAN module.

(1/2)

After reset: 0000H R/W Address: C0IE 03FEC056H, C1IE 03FEC656H

(a) Read

	15	14	13	12	11	10	9	8
CnIE	0	0	0	0	0	0	0	0
	7	6	5	4	3	2	1	0
	0	0	CIE5	CIE4	CIE3	CIE2	CIE1	CIE0

(b) Write

	15	14	13	12	11	10	9	8
CnIE	0	0	Set CIE5	Set CIE4	Set CIE3	Set CIE2	Set CIE1	Set CIE0
	7	6	5	4	3	2	1	0
	0	0	Clear CIE5	Clear CIE4	Clear CIE3	Clear CIE2	Clear CIE1	Clear CIE0

(a) Read

CIE5 to CIE0	CAN module interrupt enable bit
0	Output of the interrupt corresponding to interrupt status register CINTSx is disabled.
1	Output of the interrupt corresponding to interrupt status register CINTSx is enabled.

(b) Write

Set CIE5	Clear CIE5	Setting of CIE5 bit
0	1	CIE5 bit is cleared to 0.
1	0	CIE5 bit is set to 1.
Other than above		CIE5 bit is not changed.

Set CIE4	Clear CIE4	Setting of CIE4 bit
0	1	CIE4 bit is cleared to 0.
1	0	CIE4 bit is set to 1.
Other than above		CIE4 bit is not changed.

Set CIE3	Clear CIE3	Setting of CIE3 bit
0	1	CIE3 bit is cleared to 0.
1	0	CIE3 bit is set to 1.
Other than above		CIE3 bit is not changed.

Set CIE2	Clear CIE2	Setting of CIE2 bit
0	1	CIE2 bit is cleared to 0.
1	0	CIE2 bit is set to 1.
Other than above		CIE2 bit is not changed.

Set CIE1	Clear CIE1	Setting of CIE1 bit
0	1	CIE1 bit is cleared to 0.
1	0	CIE1 bit is set to 1.
Other than above		CIE1 bit is not changed.

Set CIE0	Clear CIE0	Setting of CIE0 bit
0	1	CIE0 bit is cleared to 0.
1	0	CIE0 bit is set to 1.
Other than above		CIE0 bit is not changed.

**(11) CANn module interrupt status register (CnINTS)**

The CnINTS register indicates the interrupt status of the CAN module.

After reset: 0000H R/W Address: C0INTS 03FEC058H, C1INTS 03FEC658H

(a) Read

	15	14	13	12	11	10	9	8
CnINTS	0	0	0	0	0	0	0	0
	7	6	5	4	3	2	1	0
	0	0	CINTS5	CINTS4	CINTS3	CINTS2	CINTS1	CINTS0

(b) Write

	15	14	13	12	11	10	9	8
CnINTS	0	0	0	0	0	0	0	0
	7	6	5	4	3	2	1	0
	0	0	Clear CINTS5	Clear CINTS4	Clear CINTS3	Clear CINTS2	Clear CINTS1	Clear CINTS0

(a) Read

CINTS5 to CINTS0	CAN interrupt status bit
0	No related interrupt source event is generated.
1	A related interrupt source event is generated.

Interrupt status bit	Related interrupt source event
CINTS5	Wakeup interrupt from CAN sleep mode <sup>Note</sup>
CINTS4	Arbitration loss interrupt
CINTS3	CAN protocol error interrupt
CINTS2	CAN error status interrupt
CINTS1	Interrupt on completion of reception of valid message frame to message buffer m
CINTS0	Interrupt on normal completion of transmission of message frame from message buffer m

**Note** The CINTS5 bit is set (1) only when the CAN module is woken up from the CAN sleep mode by a CAN bus operation. The CINTS5 bit is not set (1) when the CAN sleep mode has been released by software.

(b) Write

Clear CINTS5 to CINTS0	Setting of CINTS5 to CINTS0 bits
0	CINTS5 to CINTS0 bits are not changed.
1	CINTS5 to CINTS0 bits are cleared to 0.

**Caution** The status bit of this register is not automatically cleared. Clear it (0) by software if each status must be checked in the interrupt servicing.



**(12) CANn module bit rate prescaler register (CnBRP)**

The CnBRP register is used to select the CAN protocol layer base clock ( $f_{TQ}$ ). The communication baud rate is set to the CnBTR register.

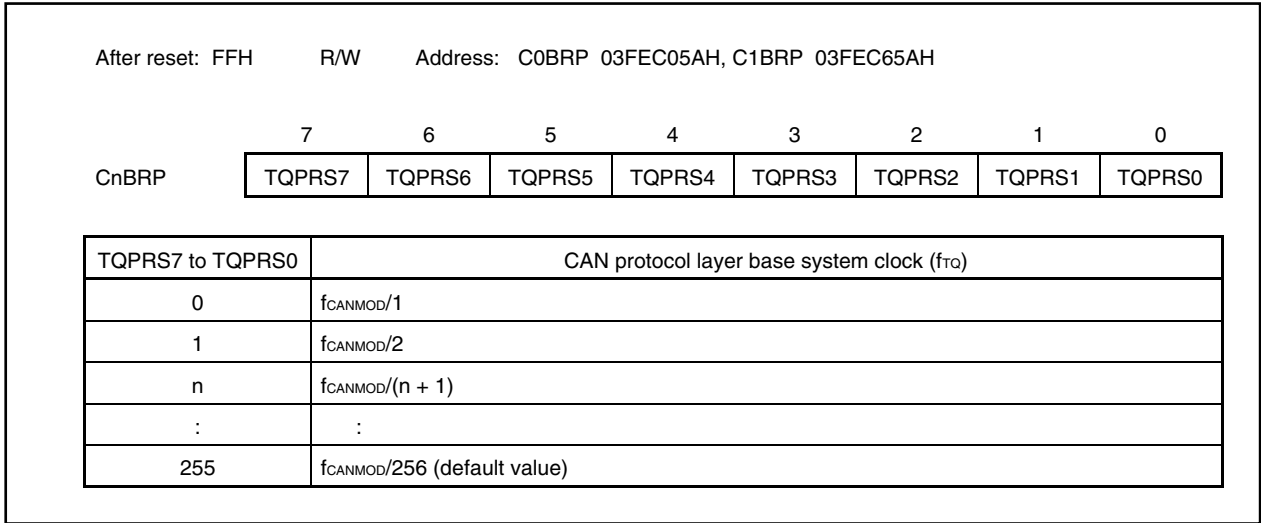

**Figure 21-23. CAN Module Clock**

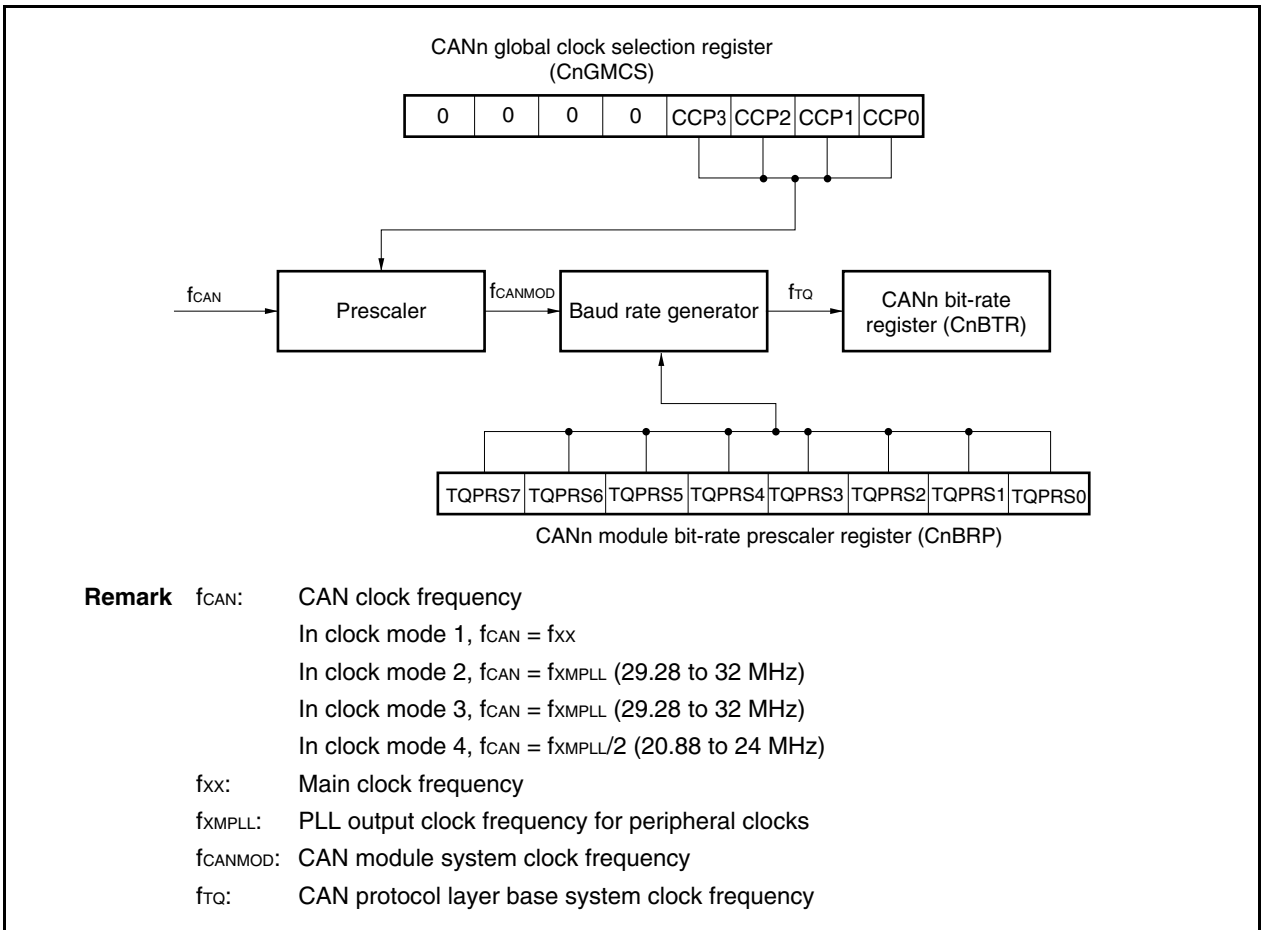

**Caution** The CnBRP register can be write-accessed only in the initialization mode.

**(13) CANn module bit rate register (CnBTR)**

The CnBTR register is used to control the data bit time of the communication baud rate.

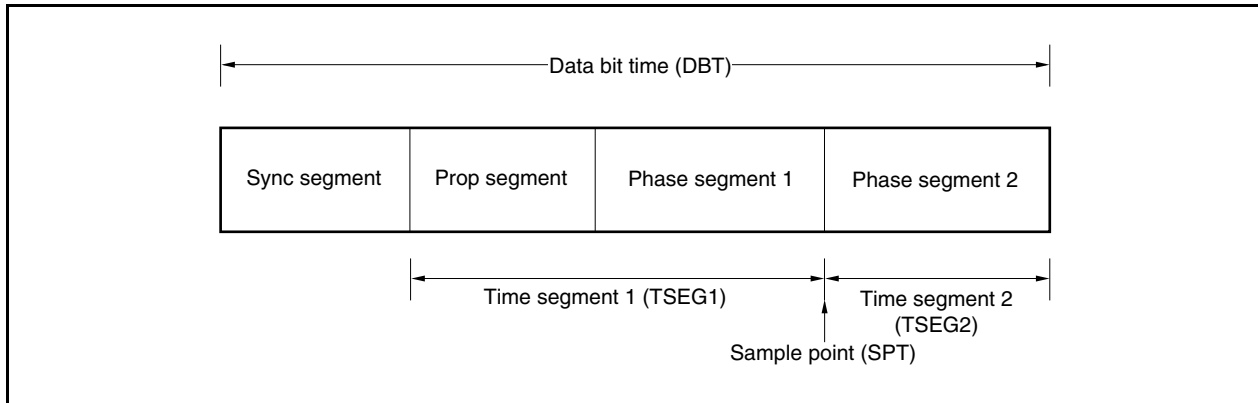
**Figure 21-24. Data Bit Time**

After reset: 370FH R/W Address: C0BTR 03FEC05CH, C1BTR 03FEC65CH

	15	14	13	12	11	10	9	8
CnBTR	0	0	SJW1	SJW0	0	TSEG22	TSEG21	TSEG20
	7	6	5	4	3	2	1	0
	0	0	0	0	TSEG13	TSEG12	TSEG11	TSEG10

SJW1	SJW0	Length of synchronization jump width
0	0	1TQ
0	1	2TQ
1	0	3TQ
1	1	4TQ (default value)

TSEG22	TSEG21	TSEG20	Length of time segment 2
0	0	0	1TQ
0	0	1	2TQ
0	1	0	3TQ
0	1	1	4TQ
1	0	0	5TQ
1	0	1	6TQ
1	1	0	7TQ
1	1	1	8TQ (default value)

TSEG13	TSEG12	TSEG11	TSEG10	Length of time segment 1
0	0	0	0	Setting prohibited
0	0	0	1	2TQ <sup>Note</sup>
0	0	1	0	3TQ <sup>Note</sup>
0	0	1	1	4TQ
0	1	0	0	5TQ
0	1	0	1	6TQ
0	1	1	0	7TQ
0	1	1	1	8TQ
1	0	0	0	9TQ
1	0	0	1	10TQ
1	0	1	0	11TQ
1	0	1	1	12TQ
1	1	0	0	13TQ
1	1	0	1	14TQ
1	1	1	0	15TQ
1	1	1	1	16TQ (default value)

**Note** This setting must not be made when the CnBRP register = 00H.

**Remark** TQ = 1/fr<sub>Q</sub> (fr<sub>Q</sub>: CAN protocol layer base system clock)

**(14) CAn module last in-pointer register (CnLIPT)**

The CnLIPT register indicates the number of the message buffer in which a data frame or a remote frame was last stored.

After reset: Undefined      R      Address: C0LIPT 03FEC05EH, C1LIPT 03FEC65EH

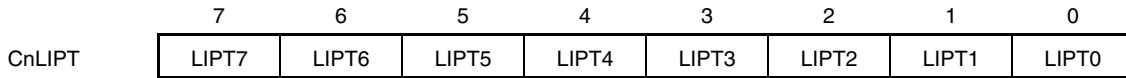

LIPT7 to LIPT0	Last in-pointer register (CnLIPT)
0 to 31	When the CnLIPT register is read, the contents of the element indexed by the last in-pointer (LIPT) of the receive history list are read. These contents indicate the number of the message buffer in which a data frame or a remote frame was last stored.

**Remark** The read value of the CnLIPT register is undefined if a data frame or a remote frame has never been stored in the message buffer. If the CnRGPT.RHPM bit is set to 1 after the CAN module has changed from the initialization mode to an operation mode, therefore, the read value of the CnLIPT register is undefined.

**(15) CAnN module receive history list register (CnRGPT)**

The CnRGPT register is used to read the receive history list.

(1/2)

After reset: xx02H R/W Address: C0RGPT 03FEC060H, C1RGPT 03FEC660H

(a) Read

	15	14	13	12	11	10	9	8
CnRGPT	RGPT7	RGPT6	RGPT5	RGPT4	RGPT3	RGPT2	RGPT1	RGPT0
	7	6	5	4	3	2	1	0
	0	0	0	0	0	0	RHPM	ROVF

(b) Write

	15	14	13	12	11	10	9	8
CnRGPT	0	0	0	0	0	0	0	0
	7	6	5	4	3	2	1	0
	0	0	0	0	0	0	0	Clear ROVF

(a) Read

RGPT7 to RGPT0	Receive history list read pointer
0 to 31	When the CnRGPT register is read, the contents of the element indexed by the receive history list get pointer (RGPT) of the receive history list are read. These contents indicate the number of the message buffer in which a data frame or a remote frame has been stored.

RHPM <sup>Note 1</sup>	Receive history list pointer match
0	The receive history list has at least one message buffer number that has not been read.
1	The receive history list has no message buffer numbers that have not been read.

ROVF <sup>Note 2</sup>	Receive history list overflow bit
0	All the message buffer numbers that have not been read are preserved. All the numbers of the message buffers in which a new data frame or remote frame has been received and stored are recorded to the receive history list (the receive history list has a vacant element).
1	At least 23 entries have been stored since the host processor serviced the RHL last time (i.e. read CnRGPT). The first 22 entries are sequentially stored whereas the last entry might have been overwritten by newly received messages a number of times because all buffer numbers are stored at position LIPT-1 when the ROVF bit is set to 1. As a consequence receptions cannot be completely recovered in the order that they were received.

- Notes**
1. The read value of the RGPT0 to RGPT7 bits is invalid when the RHPM bit = 1.
  2. If all the receive history is read by the CnRGPT register while the ROVF bit is set (1), the RHPM bit is not cleared (0) but kept set (1) even if newly received data is stored.

(b) Write

Clear ROVF	Setting of ROVF bit
0	ROVF bit is not changed.
1	ROVF bit is cleared to 0.

**(16) CANn module last out-pointer register (CnLOPT)**

The CnLOPT register indicates the number of the message buffer to which a data frame or a remote frame was transmitted last.

After reset: Undefined    R    Address: C0LOPT 03FEC062H, C1LOPT 03FEC662H

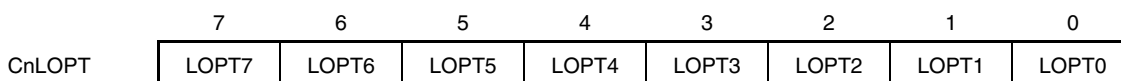

LOPT7 to LOPT0	Last out-pointer of transmit history list (LOPT)
0 to 31	When the CnLOPT register is read, the contents of the element indexed by the last out-pointer (LOPT) of the receive history list are read. These contents indicate the number of the message buffer to which a data frame or a remote frame was transmitted last.

**Remark** The value read from the CnLOPT register is undefined if a data frame or remote frame has never been transmitted from a message buffer. If the CnTGPT.THPM bit is set to 1 after the CAN module has changed from the initialization mode to an operation mode, therefore, the read value of the CnLOPT register is undefined.

**(17) CAnN module transmit history list register (CnTGPT)**

The CnTGPT register is used to read the transmit history list.

(1/2)

After reset: xx02H R/W Address: C0TGPT 03FEC064H, C1TGPT 03FEC664H

(a) Read

	15	14	13	12	11	10	9	8
CnTGPT	TGPT7	TGPT6	TGPT5	TGPT4	TGPT3	TGPT2	TGPT1	TGPT0
	7	6	5	4	3	2	1	0
	0	0	0	0	0	0	THPM	TOVF

(b) Write

	15	14	13	12	11	10	9	8
CnTGPT	0	0	0	0	0	0	0	0
	7	6	5	4	3	2	1	0
	0	0	0	0	0	0	0	Clear TOVF

(a) Read

TGPT7 to TGPT0	Transmit history list read pointer
0 to 31	When the CnTGPT register is read, the contents of the element indexed by the read pointer (TGPT) of the transmit history list are read. These contents indicate the number of the message buffer to which a data frame or a remote frame was transmitted last.

THPM <sup>Note 1</sup>	Transmit history pointer match
0	The transmit history list has at least one message buffer number that has not been read.
1	The transmit history list has no message buffer numbers that have not been read.

TOVF <sup>Note 2</sup>	Transmit history list overflow bit
0	All the message buffer numbers that have not been read are preserved. All the numbers of the message buffers to which a new data frame or remote frame has been transmitted are recorded to the transmit history list (the transmit history list has a vacant element).
1	At least 7 entries have been stored since the host processor serviced the THL last time (i.e. read CnTGPT). The first 6 entries are sequentially stored whereas the last entry might have been overwritten by newly transmitted messages a number of times because all buffer numbers are stored at position LOPT-1 when TOVF bit is set to 1. As a consequence receptions cannot be completely recovered in the order that they were received.

- Notes**
- The read value of the TGPT0 to TGPT7 bits is invalid when the THPM bit = 1.
  - If all the transmit history is read by the CnTGPT register while the TOVF bit is set (1), the THPM bit is not cleared (0) but kept set (1), even if transmission of new data has been completed.

**Remark** Transmission from message buffers 0 to 7 is not recorded to the transmit history list in the normal operation mode with ABT.

(2/2)

(b) Write

Clear TOVF	Setting of TOVF bit
0	TOVF bit is not changed.
1	TOVF bit is cleared to 0.

**(18) CANn module time stamp register (CnTS)**

The CnTS register is used to control the time stamp function.

(1/2)

After reset: 0000H    R/W    Address: C0TS 03FEC066H, C1TS 03FEC666H

(a) Read

	15	14	13	12	11	10	9	8
CnTS	0	0	0	0	0	0	0	0
	7	6	5	4	3	2	1	0
	0	0	0	0	0	TSLOCK	TSSEL	TSEN

(b) Write

	15	14	13	12	11	10	9	8
CnTS	0	0	0	0	0	Set TSLOCK	Set TSSEL	Set TSEN
	7	6	5	4	3	2	1	0
	0	0	0	0	0	Clear TSLOCK	Clear TSSEL	Clear TSEN

**Remark** The lock function of the time stamp functions must not be used when the CAN module is in the normal operation mode with ABT.



## (a) Read

TSLOCK	Time stamp lock function enable bit
0	Time stamp lock function stopped. The TSOUT signal toggles each time the selected time stamp capture event occurs.
1	Time stamp lock function enabled. The TSOUT signal toggled each time the selected time stamp capture event occurred. However, the TSOUT output signal is locked when a data frame has been correctly received to message buffer 0 <sup>Note</sup> .

**Note** The TSEN bit is automatically cleared to 0.

TSEL	Time stamp capture event selection bit
0	The time stamp capture event is SOF.
1	The time stamp capture event is the last bit of EOF.

TSEN	TSOUT operation setting bit
0	TSOUT toggle operation is disabled.
1	TSOUT toggle operation is enabled.

**Remark** The TSOUT signal is output from the CAN controller to a timer. For details, refer to **CHAPTER 7 16-BIT TIMER/EVENT COUNTER P (TMP)**.

## (b) Write

Set TSLOCK	Clear TSLOCK	Setting of TSLOCK bit
0	1	TSLOCK bit is cleared to 0.
1	0	TSLOCK bit is set to 1.
Other than above		TSLOCK bit is not changed.

Set TSEL	Clear TSEL	Setting of TSEL bit
0	1	TSEL bit is cleared to 0.
1	0	TSEL bit is set to 1.
Other than above		TSEL bit is not changed.

Set TSEN	Clear TSEN	Setting of TSEN bit
0	1	TSEN bit is cleared to 0.
1	0	TSEN bit is set to 1.
Other than above		TSEN bit is not changed.

**(19) CANn message data byte register (CnMDATAxm, CnMDATAym) (x = 0 to 7, y = 01, 23, 45, 67)**

The C0MDATAxm register is used to store the data of a transmit/receive message, and can be accessed in 8-bit unit.

The CnMDATAxm register can be accessed in 16-bit units by the CnMDATAym register.

(1/2)

After reset: Undefined    R/W    Address: See **Table 21-16**.

	15	14	13	12	11	10	9	8
CnMDATA01m	MDATA01 15	MDATA01 14	MDATA01 13	MDATA01 12	MDATA01 11	MDATA01 10	MDATA01 9	MDATA01 8
	7	6	5	4	3	2	1	0
	MDATA01 7	MDATA01 6	MDATA01 5	MDATA01 4	MDATA01 3	MDATA01 2	MDATA01 1	MDATA01 0
CnMDATA0m	7	6	5	4	3	2	1	0
	MDATA0 7	MDATA0 6	MDATA0 5	MDATA0 4	MDATA0 3	MDATA0 2	MDATA0 1	MDATA0 0
CnMDATA1m	7	6	5	4	3	2	1	0
	MDATA1 7	MDATA1 6	MDATA1 5	MDATA1 4	MDATA1 3	MDATA1 2	MDATA1 1	MDATA1 0
CnMDATA23m	15	14	13	12	11	10	9	8
	MDATA23 15	MDATA23 14	MDATA23 13	MDATA23 12	MDATA23 11	MDATA23 10	MDATA23 9	MDATA23 8
	7	6	5	4	3	2	1	0
	MDATA23 7	MDATA23 6	MDATA23 5	MDATA23 4	MDATA23 3	MDATA23 2	MDATA23 1	MDATA23 0
CnMDATA2m	7	6	5	4	3	2	1	0
	MDATA2 7	MDATA2 6	MDATA2 5	MDATA2 4	MDATA2 3	MDATA2 2	MDATA2 1	MDATA2 0
CnMDATA3m	7	6	5	4	3	2	1	0
	MDATA3 7	MDATA3 6	MDATA3 5	MDATA3 4	MDATA3 3	MDATA3 2	MDATA3 1	MDATA3 0

	15	14	13	12	11	10	9	8
CnMDATA45m	MDATA45 15	MDATA45 14	MDATA45 13	MDATA45 12	MDATA45 11	MDATA45 10	MDATA45 9	MDATA45 8
	7	6	5	4	3	2	1	0
	MDATA45 7	MDATA45 6	MDATA45 5	MDATA45 4	MDATA45 3	MDATA45 2	MDATA45 1	MDATA45 0
	7	6	5	4	3	2	1	0
CnMDATA4m	MDATA4 7	MDATA4 6	MDATA4 5	MDATA4 4	MDATA4 3	MDATA4 2	MDATA4 1	MDATA4 0
	7	6	5	4	3	2	1	0
CnMDATA5m	MDATA5 7	MDATA5 6	MDATA5 5	MDATA5 4	MDATA5 3	MDATA5 2	MDATA5 1	MDATA5 0
	15	14	13	12	11	10	9	8
CnMDATA67m	MDATA67 15	MDATA67 14	MDATA67 13	MDATA67 12	MDATA67 11	MDATA67 10	MDATA67 9	MDATA67 8
	7	6	5	4	3	2	1	0
	MDATA67 7	MDATA67 6	MDATA67 5	MDATA67 4	MDATA67 3	MDATA67 2	MDATA67 1	MDATA67 0
	7	6	5	4	3	2	1	0
CnMDATA6m	MDATA6 7	MDATA6 6	MDATA6 5	MDATA6 4	MDATA6 3	MDATA6 2	MDATA6 1	MDATA6 0
	7	6	5	4	3	2	1	0
CnMDATA7m	MDATA7 7	MDATA7 6	MDATA7 5	MDATA7 4	MDATA7 3	MDATA7 2	MDATA7 1	MDATA7 0

**(20) CANn message data length register m (CnMDLcM)**

The CnMDLcM register is used to set the number of bytes of the data field of a message buffer.

After reset: 0000xxxxB      R/W      Address: See **Table 21-16**.

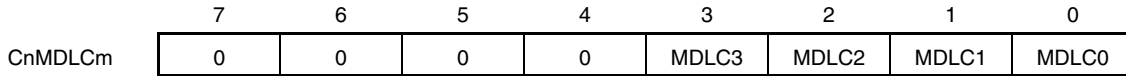

MDLC3	MDLC2	MDLC1	MDLC0	Data length of transmit/receive message
0	0	0	0	0 bytes
0	0	0	1	1 byte
0	0	1	0	2 bytes
0	0	1	1	3 bytes
0	1	0	0	4 bytes
0	1	0	1	5 bytes
0	1	1	0	6 bytes
0	1	1	1	7 bytes
1	0	0	0	8 bytes
1	0	0	1	Setting prohibited (If these bits are set during transmission, 8-byte data is transmitted regardless of the set DLC value when a data frame is transmitted. However, the DLC actually transmitted to the CAN bus is the DLC value set to this register.) <sup>Note</sup>
1	0	1	0	
1	0	1	1	
1	1	0	0	
1	1	0	1	
1	1	1	0	
1	1	1	1	

**Note** The data and DLC value actually transmitted to CAN bus are as follows.

Type of transmit frame	Length of transmit data	DLC transmitted
Data frame	Number of bytes specified by DLC (However, 8 bytes if DLC ≥ 8)	MDLC3 to MDLC0 bits
Remote frame	0 bytes	

- Cautions**
1. Receive data is stored in as many CnMDATAxm register as the number of bytes (however, the upper limit is 8) corresponding to DLC of receive frame. The CnMDATAxm register in which no data is stored is undefined.
  2. Be sure to set bits 4 to 7 to “0”.

**(21) CANn message configuration register m (CnMCONFm)**

The CnMCONFm register is used to specify the type of the message buffer and to set a mask.

(1/2)

After reset: Undefined    R/W    Address: See **Table 21-16**.

	7	6	5	4	3	2	1	0
CnMCONFm	OWS	RTR	MT2	MT1	MT0	0	0	MA0

OWS	Overwrite control bit
0	The message buffer <sup>Note</sup> that has already received a data frame is not overwritten by a newly received data frame. The newly received data frame is discarded.
1	The message buffer that has already received a data frame is overwritten by a newly received data frame.

**Note** The “message buffer that has already received a data frame” is a receive message buffer whose the CnMCTRLm.DN bit has been set to 1.

**Remark** A remote frame is received and stored, regardless of the setting of the OWS and DN bits. A remote frame that satisfies the other conditions (ID matches, the RTR bit = 0, the CnMCTRLm.TRQ bit = 0) is always received and stored in the corresponding message buffer (interrupt generated, DN flag set, the CnMDLcM.MDLC0 to CnMDLcM.MDLC3 bits updated, and recorded to the receive history list).

RTR	Remote frame request bit <sup>Note</sup>
0	Transmit a data frame.
1	Transmit a remote frame.

**Note** The RTR bit specifies the type of message frame that is transmitted from a message buffer defined as a transmit message buffer. Even if a valid remote frame has been received, the RTR bit of the transmit message buffer that has received the frame remains cleared to 0. Even if a remote frame whose ID matches has been received from the CAN bus with the RTR bit of the transmit message buffer set to 1 to transmit a remote frame, that remote frame is not received or stored (interrupt generated, DN flag set, the MDLC0 to MDLC3 bits updated, and recorded to the receive history list).

MT2	MT1	MT0	Message buffer type setting bit
0	0	0	Transmit message buffer
0	0	1	Receive message buffer (no mask setting)
0	1	0	Receive message buffer (mask 1 set)
0	1	1	Receive message buffer (mask 2 set)
1	0	0	Receive message buffer (mask 3 set)
1	0	1	Receive message buffer (mask 4 set)
Other than above			Setting prohibited

MA0	Message buffer assignment bit
0	Message buffer not used.
1	Message buffer used.

**Caution** Be sure to set bits 2 and 1 to “0”.

**(22) CANn message ID register m (CnMIDLm, CnMIDHm)**

The CnMIDLm and CnMIDHm registers are used to set an identifier (ID).

After reset: Undefined    R/W    Address: See **Table 21-16**.

CnMIDLm	15	14	13	12	11	10	9	8
	ID15	ID14	ID13	ID12	ID11	ID10	ID9	ID8
	7	6	5	4	3	2	1	0
	ID7	ID6	ID5	ID4	ID3	ID2	ID1	ID0

CnMIDHm	15	14	13	12	11	10	9	8
	IDE	0	0	ID28	ID27	ID26	ID25	ID24
	7	6	5	4	3	2	1	0
	ID23	ID22	ID21	ID20	ID19	ID18	ID17	ID16

IDE	Format mode specification bit
0	Standard format mode (ID28 to ID18: 11 bits) <sup>Note</sup>
1	Extended format mode (ID28 to ID0: 29 bits)

**Note** The ID17 to ID0 bits are not used.

ID28 to ID0	Message ID
ID28 to ID18	Standard ID value of 11 bits (when IDE = 0)
ID28 to ID0	Extended ID value of 29 bits (when IDE = 1)

- Cautions**
1. Be sure to write 0 to bits 14 and 13 of the CnMIDHm register.
  2. Be sure to arrange the ID values to be registered in accordance with the bit positions of this register. For the standard ID, shift the bit positions of ID28 to ID18 of the ID value.

**(23) CANn message control register m (CnMCTRLm)**

The CnMCTRLm register is used to control the operation of the message buffer.

(1/3)

After reset: 00x000000 R/W Address: See **Table 21-16**.  
000xx000B

(a) Read

	15	14	13	12	11	10	9	8
CnMCTRLm	0	0	MUC	0	0	0	0	0
	7	6	5	4	3	2	1	0
	0	0	0	MOW	IE	DN	TRQ	RDY

(b) Write

	15	14	13	12	11	10	9	8
CnMCTRLm	0	0	0	0	Set IE	0	Set TRQ	Set RDY
	7	6	5	4	3	2	1	0
	0	0	0	Clear MOW	Clear IE	Clear DN	Clear TRQ	Clear RDY

(a) Read

MUC <sup>Note</sup>	Bit indicating that message buffer data is being updated
0	The CAN module is not updating the message buffer (reception and storage).
1	The CAN module is updating the message buffer (reception and storage).

**Note** The MUC bit is undefined until the first reception and storage is performed.

MOW	Message buffer overwrite status bit
0	The message buffer is not overwritten by a newly received data frame.
1	The message buffer is overwritten by a newly received data frame.

**Remark** The MOW bit is not set to 1 even if a remote frame is received and stored in the transmit message buffer with the DN bit = 1.

IE	Message buffer interrupt request enable bit
0	Receive message buffer: Valid message reception completion interrupt disabled. Transmit message buffer: Normal message transmission completion interrupt disabled.
1	Receive message buffer: Valid message reception completion interrupt enabled. Transmit message buffer: Normal message transmission completion interrupt enabled.

DN	Message buffer data update bit
0	A data frame or remote frame is not stored in the message buffer.
1	A data frame or remote frame is stored in the message buffer.

TRQ	Message buffer transmission request bit
0	No message frame transmitting request that is pending or being transmitted is in the message buffer.
1	The message buffer is holding transmission of a message frame pending or is transmitting a message frame.

**Caution** Do not set the TRQ bit and RDY bit to 1 at the same time. Be sure to set the RDY bit to 1 before setting the TRQ bit to 1.

RDY	Message buffer ready bit
0	The message buffer can be written by software. The CAN module cannot write to the message buffer.
1	Writing the message buffer by software is ignored (except a write access to the RDY, TRQ, DN, and MOW bits). The CAN module can write to the message buffer.

- Cautions**
- Do not clear the RDY bit (0) during message transmission. Follow transmission abort procedures in order to clear the RDY bit for redefinition.
  - If the RDY bit is not cleared (0) even when the processing to clear it is executed, execute the clearing processing again.
  - Confirm, by reading the RDY bit again, that the RDY bit has been cleared (0) before writing data to the message buffer.  
However, it is unnecessary to confirm that the TRQ or RDY bit has been set (1) or that the DN or MOW bit has been cleared (0).

(b) Write

Clear MOW	Setting of MOW bit
0	MOW bit is not changed.
1	MOW bit is cleared to 0.

Set IE	Clear IE	Setting of IE bit
0	1	IE bit is cleared to 0.
1	0	IE bit is set to 1.
Other than above		IE bit is not changed.

**Caution** Be sure to set the IE and RDY bits separately.

Clear DN	Setting of DN bit
1	DN bit is cleared to 0.
0	DN bit is not changed.

- Cautions**
- Do not set the DN bit to 1 by software. Be sure to write 0 to bit 10.
  - If the DN bit is cleared to 0 before the arbitration field that is being received ends, the message buffer in which the data frame is being stored becomes a target destination for storing another received data frame.



Set TRQ	Clear TRQ	Setting of TRQ bit
0	1	TRQ bit is cleared to 0.
1	0	TRQ bit is set to 1.
Other than above		TRQ bit is not changed.

**Caution** Even if the TRQ bit is set (1), transmission may not be immediately executed depending on the situation such as when a message is received from another node or when a message is transmitted from the message buffer.

Transmission under execution is not terminated midway even if the TRQ bit is cleared. Transmission is continued until it is completed (regardless of whether it is executed successfully or fails).

Set RDY	Clear RDY	Setting of RDY bit
0	1	RDY bit is cleared to 0.
1	0	RDY bit is set to 1.
Other than above		RDY bit is not changed.

**Caution** Be sure to set the TRQ and RDY bits separately.

### 21.7 Bit Set/Clear Function

The CAN control registers include registers whose bits can be set or cleared via the CPU and via the CAN interface. An operation error occurs if the following registers are written directly. Do not write any values directly via bit manipulation, read/modify/write, or direct writing of target values.

- CANn global control register (CnGMCTRL)
- CANn global automatic block transmission control register (CnGMABT)
- CANn module control register (CnCTRL)
- CANn module interrupt enable register (CnIE)
- CANn module interrupt status register (CnINTS)
- CANn module receive history list register (CnRGPT)
- CANn module transmit history list register (CnTGPT)
- CANn module time stamp register (CnTS)
- CANn message control register (CnMCTRLm)

**Remark** n = 0, 1  
m = 00 to 31

All the 16 bits in the above registers can be read via the usual method. Use the procedure described in Figure 21-25 below to set or clear the lower 8 bits in these registers.

Setting or clearing of lower 8 bits in the above registers is performed in combination with the higher 8 bits (refer to the bit status after set/clear operation is specified in Figure 21-26). Figure 21-25 shows how the values of set bits or clear bits relate to set/clear/no change operations in the corresponding register.

**Figure 21-25. Example of Bit Setting/Clearing Operations**

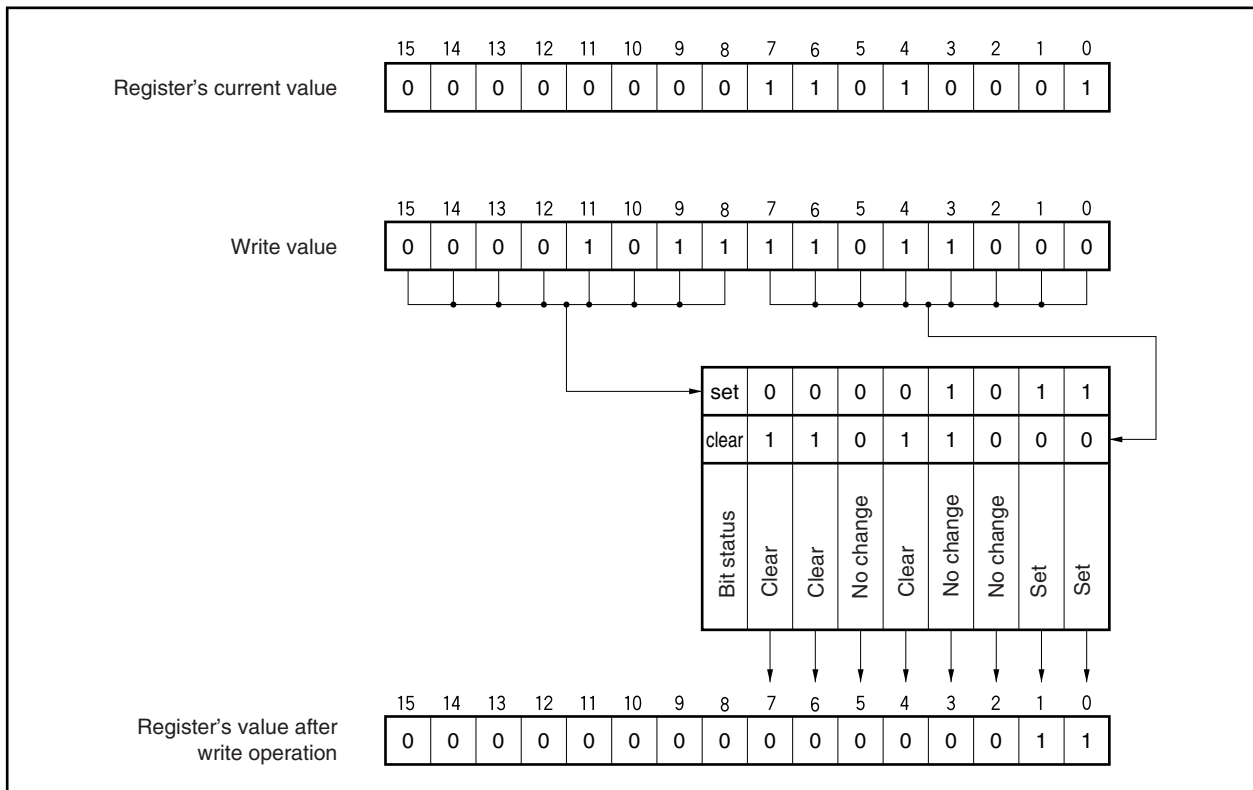

Figure 21-26. Bit Status After Bit Setting/Clearing Operations

15	14	13	12	11	10	9	8	7	6	5	4	3	2	1	0
Set 7	Set 6	Set 5	Set 4	Set 3	Set 2	Set 1	Set 0	Clear 7	Clear 6	Clear 5	Clear 4	Clear 3	Clear 2	Clear 1	Clear 0

Set n	Clear n	Status of bit n after bit set/clear operation
0	0	No change
0	1	0
1	0	1
1	1	No change

**Remark** n = 0 to 7

## 21.8 CAN Controller Initialization

### 21.8.1 Initialization of CAN module

Before CAN module operation is enabled, the CAN module system clock needs to be determined by setting the CnGMCS.CCP0 to CnGMCS.CCP3 bits by software. Do not change the setting of the CAN module system clock after CAN module operation is enabled.

The CAN module is enabled by setting the CnGMCTRL.GOM bit.

For the procedure of initializing the CAN module, see **21.16 Operation of CAN Controller**.

**Remark** n = 0, 1

### 21.8.2 Initialization of message buffer

After the CAN module is enabled, the message buffers contain undefined values. A minimum initialization for all the message buffers, even for those not used in the application, is necessary before switching the CAN module from the initialization mode to one of the operation modes.

- Clear the CnMCTRLm.RDY, CnMCTRLm.TRQ, and CnMCTRLm.DN bits to 0.
- Clear the CnMCONFm.MA0 bit to 0.

**Remark** n = 0, 1  
m = 00 to 31

### 21.8.3 Redefinition of message buffer

Redefining a message buffer means changing the ID and control information of the message buffer while a message is being received or transmitted, without affecting other transmission/reception operations.

#### (1) To redefine message buffer in initialization mode

Place the CAN module in the initialization mode once and then change the ID and control information of the message buffer in the initialization mode. After changing the ID and control information, set the CAN module to an operation mode.

#### (2) To redefine message buffer during reception

Perform redefinition as shown in Figure 21-39.

#### (3) To redefine message buffer during transmission

To rewrite the contents of a transmit message buffer to which a transmission request has been set, perform transmission abort processing (see **21.10.4 (1) Transmission abort process other than in normal operation mode with automatic block transmission (ABT)**, **21.10.4 (2) Transmission abort process except for ABT transmission in normal operation mode with automatic block transmission (ABT)**). Confirm that transmission has been aborted or completed, and then redefine the message buffer. After redefining the transmit message buffer, set a transmission request using the procedure described below. When setting a transmission request to a message buffer that has been redefined without aborting the transmission in progress, however, the 1-bit wait time is not necessary.

Figure 21-27. Setting Transmission Request (TRQ) to Transmit Message Buffer After Redefinition

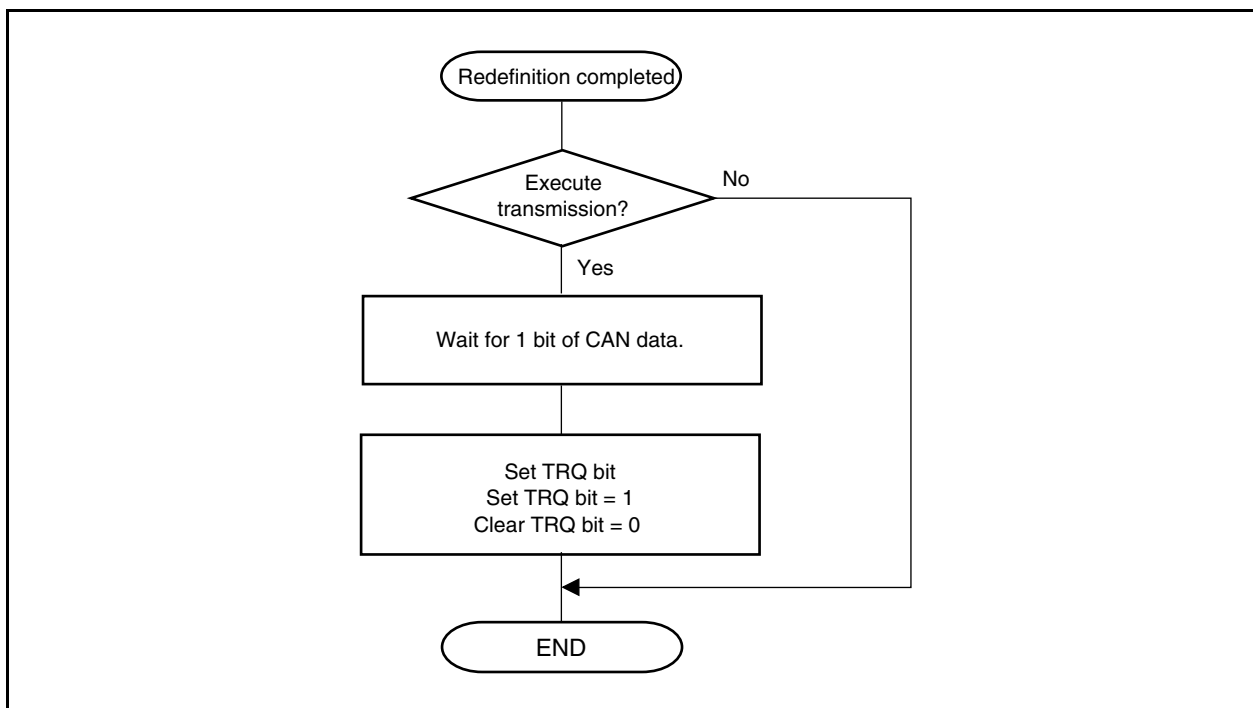

- Cautions 1.** When a message is received, reception filtering is performed in accordance with the ID and mask set to each receive message buffer. If the procedure in Figure 21-39 is not observed, the contents of the message buffer after it has been redefined may contradict the result of reception (result of reception filtering). If this happens, check that the ID and IDE received first and stored in the message buffer following redefinition are those stored after the message buffer has been redefined. If no ID and IDE are stored after redefinition, redefine the message buffer again.
- 2.** When a message is transmitted, the transmission priority is checked in accordance with the ID, IDE, and RTR bits set to each transmit message buffer to which a transmission request was set. The transmit message buffer having the highest priority is selected for transmission. If the procedure in Figure 21-27 is not observed, a message with an ID not having the highest priority may be transmitted after redefinition.

#### 21.8.4 Transition from initialization mode to operation mode

The CAN module can be switched to the following operation modes.

- Normal operation mode
- Normal operation mode with ABT
- Receive-only mode
- Single-shot mode
- Self-test mode

Figure 21-28. Transition to Operation Modes

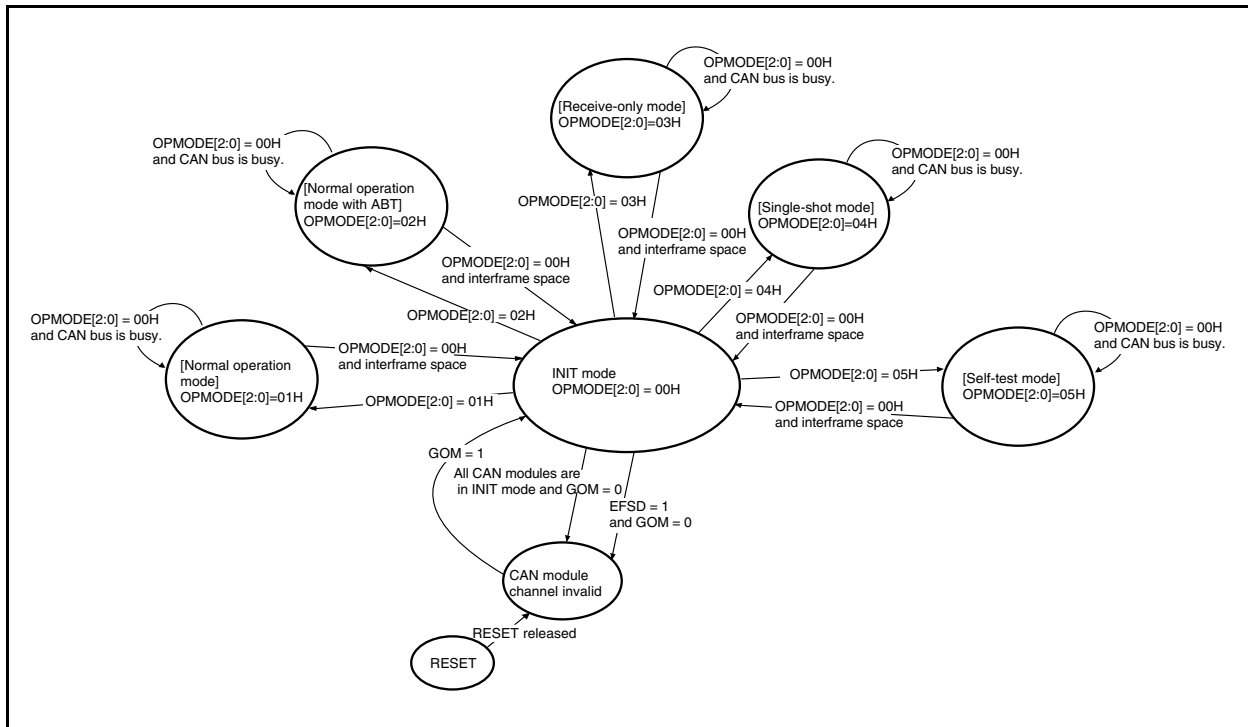

The transition from the initialization mode to an operation mode is controlled by the CnCTRL.OPMODE2 to CnCTRL.OPMODE0 bits.

Changing from one operation mode into another requires shifting to the initialization mode in between. Do not change one operation mode to another directly; otherwise the operation will not be guaranteed.

Requests for transition from an operation mode to the initialization mode are held pending when the CAN bus is not in the interframe space (i.e., frame reception or transmission is in progress), and the CAN module enters the initialization mode at the first bit in the interframe space (the values of the OPMODE2 to OPMODE0 bits are changed to 000B). After issuing a request to change the mode to the initialization mode, read the OPMODE2 to OPMODE0 bits until their values become 000B to confirm that the module has entered the initialization mode (see **Figure 21-37**).

**Remark** n = 0, 1

### 21.8.5 Resetting error counter CnERC of CAN module

If it is necessary to reset the CnERC and CnINFO registers when re-initialization or forced recovery from the bus-off status is made, set the CnCTRL.CCERC bit to 1 in the initialization mode. When this bit is set to 1, the CnERC and CnINFO registers are cleared to their default values.

**Remark** n = 0, 1

## 21.9 Message Reception

### 21.9.1 Message reception

All buffers satisfying the following conditions are searched in all the message buffer areas in all the operation modes in order to store newly receive messages.

- Used as a message buffer  
(CnMCONFm.MA0 bit is set to 1.)
- Set as a receive message buffer  
(CnMCONFm.MT2 to CnMCONFm.MT0 bits are set to 001B, 010B, 011B, 100B, or 101B.)
- Ready for reception  
(CnMCTRLm.RDY bit is set to 1.)

**Remark** n = 0, 1  
m = 00 to 31

When two or more message buffers of the CAN module receive a message, the message is stored according to the priority explained below. The message is always stored in the message buffer with the highest priority, not in a message buffer with a low priority. For example, when an unmasked receive message buffer and a receive message buffer linked to mask 1 have the same ID, the received message is not stored in the message buffer linked to mask 1 that has not received a message, even if a message has already been received in the unmasked receive message buffer. In other words, when a condition has been set to store a message in two or more message buffers with different priorities, the message buffer with the highest priority always stores the message; the message is not stored in message buffers with a lower priority. This also applies when the message buffer with the highest priority is unable to receive and store a message (i.e., when the DN bit = 1 indicating that a message has already been received, but rewriting is disabled because the OWS bit = 0). In this case, the message is not actually received and stored in the candidate message buffer with the highest priority, but neither is it stored in a message buffer with a lower priority.

Priority	Storing Condition If Same ID Is Set	
1 (high)	Unmasked message buffer	DN bit = 0
		DN bit = 1 and OWS bit = 1
2	Message buffer linked to mask 1	DN bit = 0
		DN bit = 1 and OWS bit = 1
3	Message buffer linked to mask 2	DN bit = 0
		DN bit = 1 and OWS bit = 1
4	Message buffer linked to mask 3	DN bit = 0
		DN bit = 1 and OWS bit = 1
5 (low)	Message buffer linked to mask 4	DN bit = 0
		DN bit = 1 and OWS bit = 1

21.9.2 Reading reception data

If it is necessary to consistently read data from the CAN message buffer by software, follow the recommended procedures shown in Figures 21-49 and 21-50.

While receiving a message, the CAN module sets the CnMCTRLm.DN bit two times, at the beginning of the processing to store data in the message buffer and at the end of this storing processing. During this storing processing, the CnMCTRLm.MUC bit of the message buffer is set (1) (refer to **Figure 21-29**).

Before the data is completely stored, the receive history list is written. During this data storing period (MUC bit = 1), the CPU is prohibited from rewriting the CnMCTRLm.RDY bit of the message buffer in which the data is to be stored. Completion of this data storing processing may be delayed by a CPU's access to any message buffer.

**Remark** n = 0, 1  
m = 0 to 31

Figure 21-29. DN and MUC Bit Setting Period (in Standard ID Format)

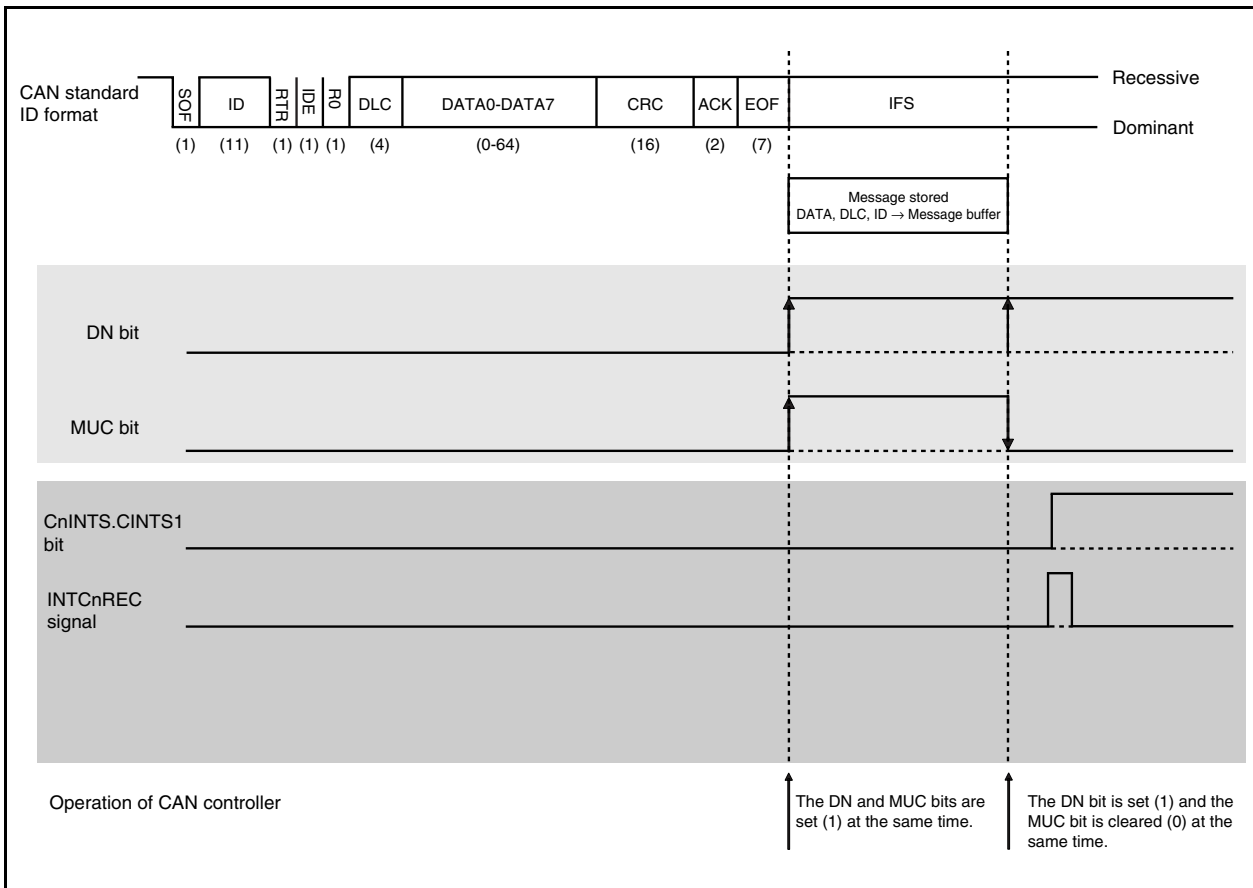



### 21.9.3 Receive history list function

The receive history list (RHL) function records in the receive history list the number of the receive message buffer in which each data frame or remote frame was received and stored. The RHL consists of storage elements equivalent to up to 23 messages, the last in-message pointer (LIPT) with the corresponding CnLIPT register and the receive history list get pointer (RGPT) with the corresponding CnRGPT register.

The RHL is undefined immediately after the transition of the CAN module from the initialization mode to one of the operation modes.

The CnLIPT register holds the contents of the RHL element indicated by the value of the LIPT pointer minus 1. By reading the CnLIPT register, therefore, the number of the message buffer that received and stored a data frame or remote frame first can be checked. The LIPT pointer is utilized as a write pointer that indicates to what part of the RHL a message buffer number is recorded. Any time a data frame or remote frame is received and stored, the corresponding message buffer number is recorded to the RHL element indicated by the LIPT pointer. Each time recording to the RHL has been completed, the LIPT pointer is automatically incremented. In this way, the number of the message buffer that has received and stored a frame will be recorded chronologically.

The RGPT pointer is utilized as a read pointer that reads a recorded message buffer number from the RHL. This pointer indicates the first RHL element that the CPU has not read yet. By reading the CnRGPT register by software, the number of a message buffer that has received and stored a data frame or remote frame can be read. Each time a message buffer number is read from the CnRGPT register, the RGPT pointer is automatically incremented.

If the value of the RGPT pointer matches the value of the LIPT pointer, the CnRGPT.RHPM bit (receive history list pointer match) is set to 1. This indicates that no message buffer number that has not been read remains in the RHL. If a new message buffer number is recorded, the LIPT pointer is incremented and because its value no longer matches the value of the RGPT pointer, the RHPM bit is cleared. In other words, the numbers of the unread message buffers exist in the RHL.

If the LIPT pointer is incremented and matches the value of the RGPT pointer minus 1, the CnRGPT.ROVF bit (receive history list overflow) is set to 1. This indicates that the RHL is full of numbers of message buffers that have not been read. When further message reception and storing occur, the last recorded message buffer number is overwritten by the number of the message buffer that received and stored the new message. After the ROVF bit has been set to 1, the recorded message buffer numbers in the RHL do not completely reflect chronological order. However the messages themselves are not lost and can be located by a CPU search in the message buffer memory with the help of the DN bit.

**Caution** Even if the receive history list overflows (CnRGPT.ROVF bit = 1), the receive history can be read until no more history is left unread and the CnRGPT.RHPM bit is set (1). However, the ROVF bit is kept set (1) (= overflow occurs) until cleared (0) by software. In this status, the RHPM bit is not cleared (0), unless the ROVF bit is cleared (0), even if a new receive history is stored and written to the list. If ROVF bit = 1 and RHPM bit = 1 and the receive history list overflows, therefore, the RHPM bit indicates that no more history is left unread even if new history is received and stored.

**Remark** n = 0, 1

As long as the RHL contains 23 or less entries the sequence of occurrence is maintained. If more receptions occur without the RHL being read by the host processor, a complete sequence of receptions can not be recovered.

Figure 21-30. Receive History List

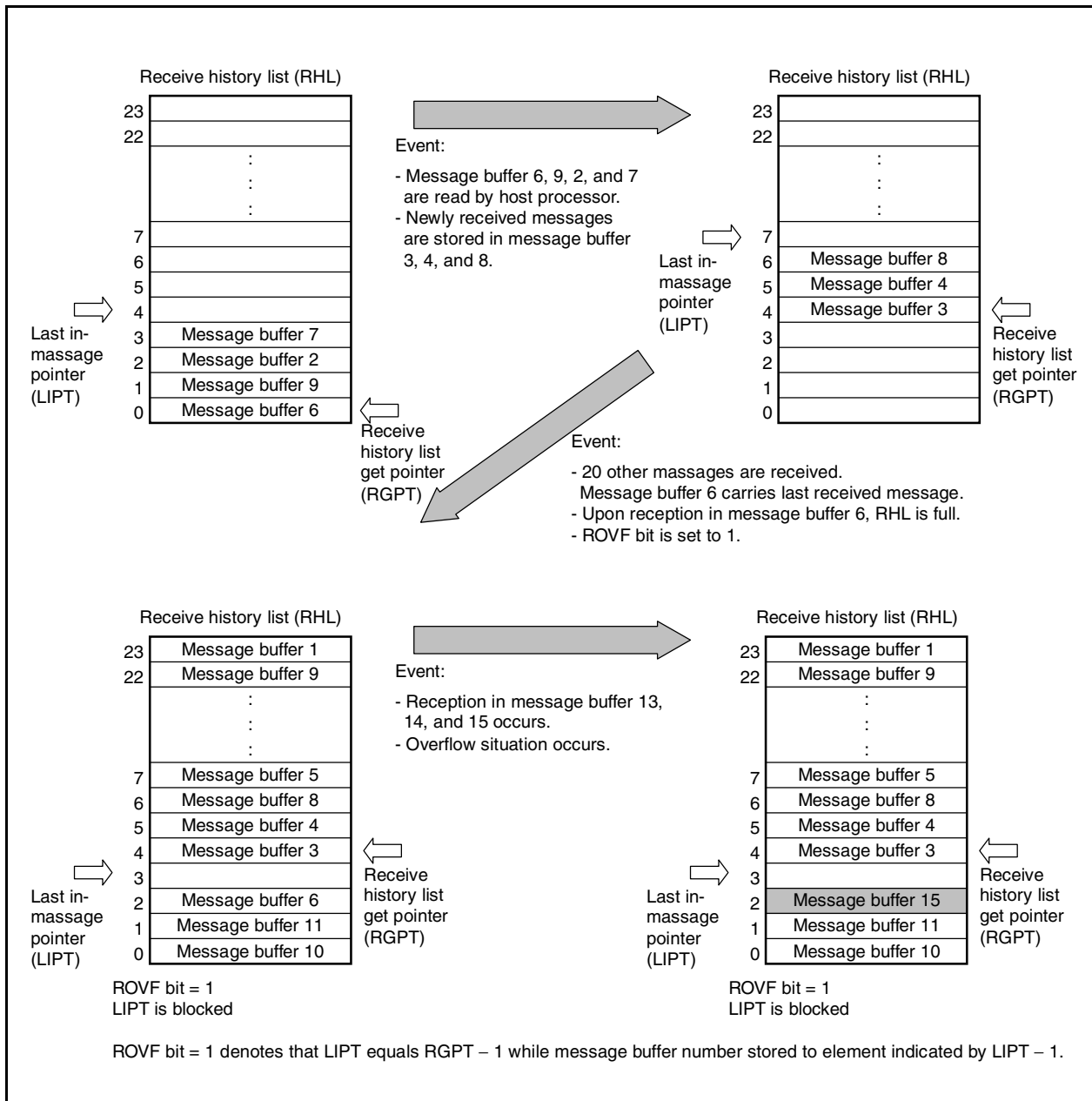

**21.9.4 Mask function**

For some message buffers that are used for reception, whether one of four global reception masks is applied can be selected.

Load resulting from comparing message identifiers is reduced by masking some bits, and, as a result, some different identifiers can be received in a buffer.

By using the mask function, the identifier of a message received from the CAN bus can be compared with the identifier set to a message buffer in advance. Regardless of whether the masked ID is set to 0 or 1, the received message can be stored in the defined message buffer.

While the mask function is in effect, an identifier bit that is defined to be 1 by a mask in the received message is not compared with the corresponding identifier bit in the message buffer.

However, this comparison is performed for any bit whose value is defined as 0 by the mask.

For example, let us assume that all messages that have a standard-format ID, in which bits ID27 to ID25 are 0 and bits ID24 and ID22 are 1, are to be stored in message buffer 14. The procedure for this example is shown below.

<1> Identifier to be stored in message buffer

ID28	ID27	ID26	ID25	ID24	ID23	ID22	ID21	ID20	ID19	ID18
x	0	0	0	1	x	1	x	x	x	x

**Remark** x = don't care

<2> Identifier to be configured in message buffer 14 (example)  
(Using COMIDL14 and COMIDH14 registers)

ID28	ID27	ID26	ID25	ID24	ID23	ID22	ID21	ID20	ID19	ID18
x	0	0	0	1	x	1	x	x	x	x
ID17	ID16	ID15	ID14	ID13	ID12	ID11	ID10	ID9	ID8	ID7
x	x	x	x	x	x	x	x	x	x	x
ID6	ID5	ID4	ID3	ID2	ID1	ID0				
x	x	x	x	x	x	x				

ID with the ID27 to ID25 bits cleared to 0 and the ID24 and ID22 bits set to 1 is registered (initialized) to message buffer 14.

**Remark** x = don't care

- Remarks**
1. Message buffer 14 is set as a standard format identifier that is linked to mask 1 (CnMCONF14.MT2 to CnMCONF14.MT0 bits are set to 010B).
  2. n = 0, 1

<3> Mask setting for CAN module 1 (mask 1) (Example)  
 (Using CAN1 address mask 1 registers L and H (C1MASK1L and C1MASK1H))

CMID28	CMID27	CMID26	CMID25	CMID24	CMID23	CMID22	CMID21	CMID20	CMID19	CMID18
1	0	0	0	0	1	0	1	1	1	1
CMID17	CMID16	CMID15	CMID14	CMID13	CMID12	CMID11	CMID10	CMID9	CMID8	CMID7
1	1	1	1	1	1	1	1	1	1	1
CMID6	CMID5	CMID4	CMID3	CMID2	CMID1	CMID0				
1	1	1	1	1	1	1				

1: Not compared (masked)  
 0: Compared

The CMID27 to CMID24 and CMID22 bits are cleared to 0, and the CMID28, CMID23, and CMID21 to CMID0 bits are set to 1.

### 21.9.5 Multi buffer receive block function

The multi buffer receive block (MBRB) function is used to store a block of data in two or more message buffers sequentially with no CPU interaction, by setting the same ID to two or more message buffers with the same message buffer type. These message buffers can be allocated in any area in the message buffer memory, and they are not necessarily to be allocated adjacent to each other.

Suppose, for example, the same message buffer type is set to 10 message buffers, message buffers 10 to 19, and the same ID is set to each message buffer. If the first message whose ID matches an ID of the message buffers is received, it is stored in message buffer 10. At this point, the DN bit of message buffer 10 is set, prohibiting overwriting the message buffer.

When the next message with a matching ID is received, it is received and stored in message buffer 11. Each time a message with a matching ID is received, it is sequentially (in the ascending order) stored in message buffers 12, 13, and so on. Even when a data block consisting of multiple messages is received, the messages can be stored and received without overwriting the previously received matching-ID data.

Whether a data block has been received and stored can be checked by setting the CnMCTRLm.IE bit of each message buffer. For example, if a data block consists of k messages, k message buffers are initialized for reception of the data block. The IE bit in message buffers 0 to (k-2) is cleared to 0 (interrupts disabled), and the IE bit in message buffer k-1 is set to 1 (interrupts enabled). In this case, a reception completion interrupt occurs when a message has been received and stored in message buffer k-1, indicating that MBRB has become full. Alternatively, by clearing the IE bit of message buffers 0 to (k-3) and setting the IE bit of message buffer k-2, a warning that MBRB is about to overflow can be issued.

The basic conditions of storing receive data in each message buffer for the MBRB are the same as the conditions of storing data in a single message buffer.

- Cautions**
1. **MBRB can be configured for each of the same message buffer types. Therefore, even if a message buffer of another MBRB whose ID matches but whose message buffer type is different has a vacancy, the received message is not stored in that message buffer, but instead discarded.**
  2. **MBRB does not have a ring buffer structure. Therefore, after a message is stored in the message buffer having the highest number in the MBRB configuration, a newly received message will no longer be stored in the message buffer in the order from the lowest message buffer number.**
  3. **MBRB operates based on the reception and storage conditions; there are no settings dedicated to MBRB, such as function enable bits. By setting the same message buffer type and ID to two or more message buffers, MBRB is automatically configured.**
  4. **With MBRB, “matching ID” means “matching ID after mask”. Even if the ID set to each message buffer is not the same, if the ID that is masked by the mask register matches, it is considered a matching ID and the buffer that has this ID is treated as the storage destination of a message.**
  5. **Priority among each MBRB conforms to the priority shown in 21.9.1 Message reception.**

**Remark** n = 0, 1  
m = 00 to 31

### 21.9.6 Remote frame reception

In all the operation modes, when a remote frame is received, the message buffer that is to store the remote frame is searched from all the message buffers satisfying the following conditions.

- Used as a message buffer  
(CnMCONFm.MA0 bit set to 1.)
- Set as a transmit message buffer  
(CnMCONFm.MT2 to CnMCONFm.MT0 bits set to 000B)
- Ready for reception  
(CnMCTRLm.RDY bit set to 1.)
- Set to transmit message  
(CnMCONFm.RTR bit is cleared to 0.)
- Transmission request is not set.  
(CnMCTRLm.TRQ bit is set to 0.)

Upon acceptance of a remote frame, the following actions are executed if the ID of the received remote frame matches the ID of a message buffer that satisfies the above conditions.

- The CnMDLcM.DLC3 to CnMDLcM.DLC0 bits store the received DLC value.
- The CnMDATA0m to CnMDATA7m registers in the data area are not updated (data before reception is saved).
- The CnMCTRLm.DN bit is set to 1.
- The CnINTS.CINTS1 bit is set to 1 (if the CnMCTRLm.IE bit of the message buffer that receives and stores the frame is set to 1).
- The receive completion interrupt (INTCnREC) is output (if the IE bit of the message buffer that receives and stores the frame is set to 1 and if the CnIE.CIE1 bit is set to 1).
- The message buffer number is recorded in the receive history list.

**Caution** When a message buffer is searched for receiving and storing a remote frame, overwrite control by the CnMCONFm.OWS bit of the message buffer and the DN bit are not affected. The setting of the OWS bit is ignored and the DN bit is set to 1 in every case.

If more than one transmit message buffer has the same ID and the ID of the received remote frame matches that ID, the remote frame is stored in the transmit message buffer with the lowest message buffer number.

**Remark** n = 0, 1  
m = 00 to 31

## 21.10 Message Transmission

### 21.10.1 Message transmission

In all the operation modes, if the CnMCTRLm.TRQ bit is set to 1 in a message buffer that satisfies the following conditions, the message buffer that is to transmit a message is searched.

- Used as a message buffer  
(CnMCONFm.MA0 bit set to 1.)
- Set as a transmit message buffer  
(CnMCONFm.MT2 to CnMCONFm.MT0 bits set to 000B.)
- Ready for transmission  
(CnMCTRLm.RDY bit is set to 1.)

**Remark** n = 0, 1  
m = 00 to 31

The CAN system is a multi-master communication system. In a system like this, the priority of message transmission is determined based on message identifiers (IDs). To facilitate transmission processing by software when there are several messages awaiting transmission, the CAN module uses hardware to check the ID of the message with the highest priority and automatically identifies that message. This eliminates the need for software-based priority control.

Transmission priority is controlled by the identifier (ID).

**Figure 21-31. Message Processing Example**

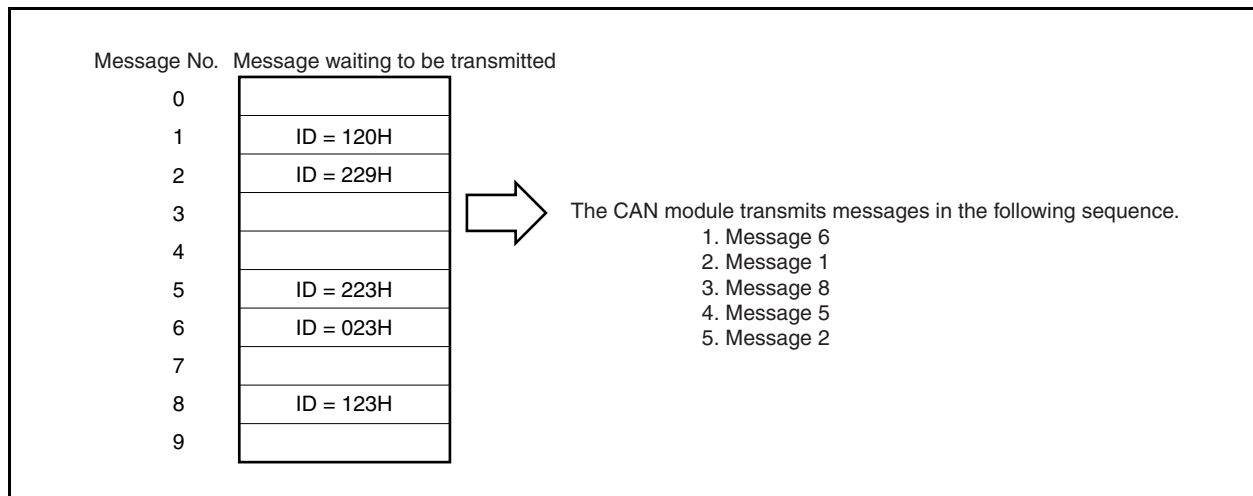

After the transmit message search, the transmit message with the highest priority of the transmit message buffers that have a pending transmission request (message buffers with the TRQ bit set to 1 in advance) is transmitted.

If a new transmission request is set, the transmit message buffer with the new transmission request is compared with the transmit message buffer with a pending transmission request. If the new transmission request has a higher priority, it is transmitted, unless transmission of a message with a low priority has already started. To solve this reversal of priorities, software can request that transmission of a message of low priority be stopped. The highest priority is determined according to the following rules.

Priority	Conditions	Description
1 (high)	Value of first 11 bits of ID [ID28 to ID18]:	The message frame with the lowest value represented by the first 11 bits of the ID is transmitted first. If the value of an 11-bit standard ID is equal to or smaller than the first 11 bits of a 29-bit extended ID, the 11-bit standard ID has a higher priority than a message frame with a 29-bit extended ID.
2	Frame type	A data frame with an 11-bit standard ID (CnMCONFm.RTR bit is cleared to 0) has a higher priority than a remote frame with a standard ID and a message frame with an extended ID.
3	ID type	A message frame with a standard ID (CnMIDHm.IDE bit is cleared to 0) has a higher priority than a message frame with an extended ID.
4	Value of lower 18 bits of ID [ID17 to ID0]:	If one or more transmission-pending extended ID message frame has equal values in the first 11 bits of the ID and the same frame type (equal RTR bit values), the message frame with the lowest value in the lower 18 bits of its extended ID is transmitted first.
5 (low)	Message buffer number	If two or more message buffers request transmission of message frames with the same ID, the message from the message buffer with the lowest message buffer number is transmitted first.

**Remarks 1.** If the automatic block transmission request bit CnGMABT.ABTTRG bit is set to 1 in the normal operation mode with ABT, the TRQ bit is set to 1 only for one message buffer in the ABT message buffer group.

If the ABT mode was triggered by the ABTTRG bit (1), one TRQ bit is set to 1 in the ABT area (buffers 0 to 7). In addition to this TRQ bit, the application can request transmissions (set TRQ bit to 1) for other TX-message buffers that do not belong to the ABT area. In that case an internal arbitration process (TX-search) evaluates all of the TX-message buffers with the TRQ bit set to 1 and chooses the message buffer that contains the highest prioritized identifier for the next transmission. If there are 2 or more identifiers that have the highest priority (i.e. identical identifiers), the message located at the lowest message buffer number is transmitted first.

Upon successful transmission of a message frame, the following operations are performed.

- The TRQ bit of the corresponding transmit message buffer is automatically cleared to 0.
  - The transmission completion status bit CINTS0 of the CnINTS register is set to 1 (if the interrupt enable bit (IE) of the corresponding transmit message buffer is set to 1).
  - An interrupt request signal INTCnTRX is output (if the CnIE.CIE0 bit is set to 1 and if the interrupt enable bit (IE) of the corresponding transmit message buffer is set to 1).
2. Before changing the contents of the transmit message buffer, the RDY flag of this buffer must be cleared. Since the RDY flag may be temporarily locked while the internal processing is changed, it is necessary to check the status of the RDY flag by software after changing the buffer contents.
  3. n = 0, 1  
m = 00 to 31



### 21.10.2 Transmit history list function

The transmit history list (THL) function records in the transmit history list the number of the transmit message buffer in which each data frame or remote frame was received and stored. The THL consists of storage elements equivalent to up to seven messages, the last out-message pointer (LOPT) with the corresponding CnLOPT register, and the transmit history list get pointer (TGPT) with the corresponding CnTGPT register.

The THL is undefined immediately after the transition of the CAN module from the initialization mode to one of the operation modes.

The CnLOPT register holds the contents of the THL element indicated by the value of the LOPT pointer minus 1. By reading the CnLOPT register, therefore, the number of the message buffer that transmitted a data frame or remote frame first can be checked. The LOPT pointer is utilized as a write pointer that indicates to what part of the THL a message buffer number is recorded. Any time a data frame or remote frame is transmitted, the corresponding message buffer number is recorded to the THL element indicated by the LOPT pointer. Each time recording to the THL has been completed, the LOPT pointer is automatically incremented. In this way, the number of the message buffer that has received and stored a frame will be recorded chronologically.

The TGPT pointer is utilized as a read pointer that reads a recorded message buffer number from the THL. This pointer indicates the first THL element that the CPU has not yet read. By reading the CnTGPT register by software, the number of a message buffer that has completed transmission can be read. Each time a message buffer number is read from the CnTGPT register, the TGPT pointer is automatically incremented.

If the value of the TGPT pointer matches the value of the LOPT pointer, the CnTGPT.THPM bit (transmit history list pointer match) is set to 1. This indicates that no message buffer numbers that have not been read remain in the THL. If a new message buffer number is recorded, the LOPT pointer is incremented and because its value no longer matches the value of the TGPT pointer, the THPM bit is cleared. In other words, the numbers of the unread message buffers exist in the THL.

If the LOPT pointer is incremented and matches the value of the TGPT pointer minus 1, the TOVF bit (transmit history list overflow) of the CnTGPT register is set to 1. This indicates that the THL is full of message buffer numbers that have not been read. If a new message is received and stored, the message buffer number recorded last is overwritten by the number of the message buffer that received and stored the new message. After the TOVF bit has been set (1), therefore, the recorded message buffer numbers in the THL do not completely reflect chronological order. However the transmitted messages can be found by a CPU search applied to all transmit message buffers unless the CPU has not overwritten a transmit object in one of these buffers beforehand. In total up to six transmission completions can occur without overflowing the THL.

**Caution** Even if the transmit history list overflows (CnTGPT.TOVF bit = 1), the transmit history can be read until no more history is left unread and the CnTGPT.THPM bit is set (1). However, the TOVF bit is kept set (1) (= overflow occurs) until cleared (0) by software. In this status, the THPM bit is not cleared (0), unless the TOVF bit is cleared (0), even if a new transmit history is stored and written to the list. If the TOVF bit = 1 and the THPM bit = 1 and the receive history list overflows, therefore, the THPM bit indicates that no more history is left unread even if new history is received and stored.

**Remark** n = 0, 1

Figure 21-32. Transmit History List

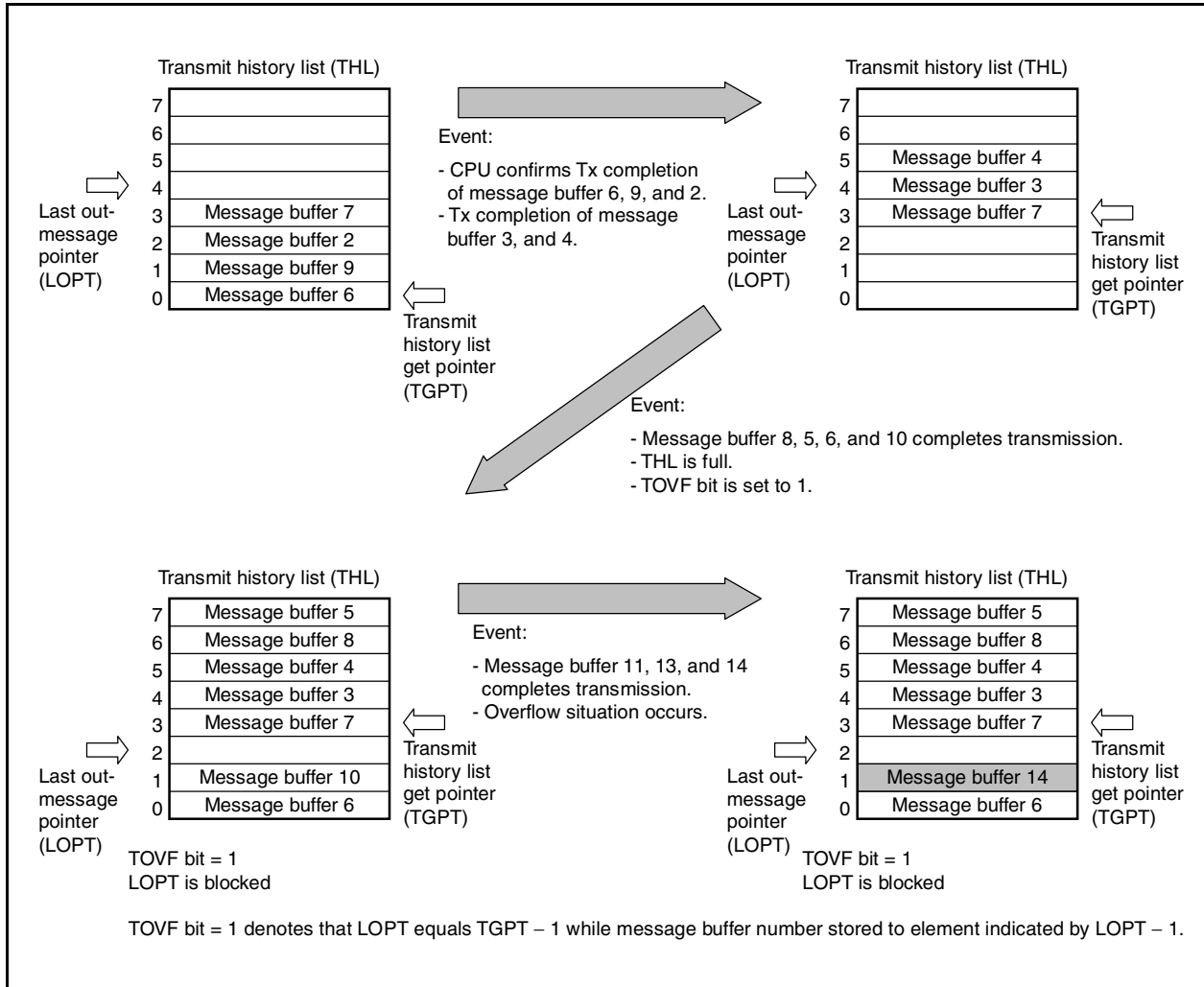

### 21.10.3 Automatic block transmission (ABT)

The automatic block transmission (ABT) function is used to transmit two or more data frames successively with no CPU interaction. The maximum number of transmit message buffers assigned to the ABT function is eight (message buffer numbers 0 to 7).

By setting the CnCTRL.OPMODE2 to CnCTRL.OPMODE0 bits to 010B, “normal operation mode with automatic block transmission function” (hereafter referred to as ABT mode) can be selected.

To issue an ABT transmission request, define the message buffers by software first. Set the CnMCONFm.MA0 bit (1) in all the message buffers used for ABT, and define all the buffers as transmit message buffers by setting the CnMCONFm.MT2 to CnMCONFm.MT0 bits to 000B. Be sure to set the ID for the message buffers for ABT for each message buffer, even when that ID is being used for all the message buffers. To use two or more IDs, set the ID of each message buffer by using the CnMIDLm and CnMIDHm registers. Set the CnMDLcm and CnMDATA0m to CnMDATA7m registers before issuing a transmission request for the ABT function.

After initialization of message buffers for ABT is finished, the CnMCTRLm.RDY bit needs to be set (1). In the ABT mode, the CnMCTRLm.TRQ bit does not have to be manipulated by software.

After the data for the ABT message buffers has been prepared, set the CnGMABT.ABTTRG bit to 1. Automatic block transmission is then started. When ABT is started, the TRQ bit in the first message buffer (message buffer 0) is automatically set to 1. After transmission of the data of message buffer 0 is finished, the TRQ bit of the next message buffer, message buffer 1, is set automatically. In this way, transmission is executed successively.

A delay time can be inserted by program in the interval in which the transmission request (TRQ bit) is automatically set while successive transmission is being executed. The delay time to be inserted is defined by the CnGMABTD register. The unit of the delay time is DBT (data bit time). DBT depends on the setting of the CnBRP and CnBTR registers.

During ABT, the priority of the transmission ID is not searched in the ABT transmit message buffer. The data of message buffers 0 to 7 is sequentially transmitted. When transmission of the data frame from message buffer 7 has been completed, the ABTTRG bit is automatically cleared to 0 and the ABT operation is finished.

If the RDY bit of an ABT message buffer is cleared during ABT, no data frame is transmitted from that buffer, ABT is stopped, and the ABTTRG bit is cleared. After that, transmission can be resumed from the message buffer where ABT stopped, by setting the RDY and ABTTRG bits to 1 by software. To not resume transmission from the message buffer where ABT stopped, the internal ABT engine can be reset by setting the CnGMABT.ABTCLR bit to 1 while ABT mode is stopped and the ABTTRG bit is cleared to 0. In this case, transmission is started from message buffer 0 if the ABTCLR bit is cleared to 0 and then the ABTTRG bit is set to 1.

An interrupt can be used to check if data frames have been transmitted from all the message buffers for ABT. To do so, the CnMCTRLm.IE bit of each message buffer except the last message buffer needs to be cleared (0).

If a transmit message buffer other than those used by the ABT function (message buffers 8 to 31) is assigned to a transmit message buffer, the priority of the message to be transmitted is determined by the priority of the transmission message buffer of the ABT message buffer whose transmission is currently held pending and the transmission message buffer of the message buffers other than those used by the ABT function.

Transmission of a data frame from an ABT message buffer is not recorded in the transmit history list (THL).

- Cautions**
1. To resume the normal operation mode with ABT from the message buffer 0, set the ABTCLR bit to 1 while the ABTTRG bit is cleared to 0. If the ABTCLR bit is set to 1 while the ABTTRG bit is set to 1, the subsequent operation is not guaranteed.
  2. Whether the automatic block transmission engine is cleared by setting the ABTCLR bit to 1 can be confirmed if the ABTCLR bit is automatically cleared to 0 immediately after the processing of the clearing request is completed.
  3. Do not set the ABTTRG bit in the initialization mode. If the ABTTRG bit is set in the initialization mode, the proper operation is not guaranteed after the mode is changed from the initialization mode to the ABT mode.
  4. Do not set the TRQ bit of the ABT message buffers to 1 by software in the normal operation mode with ABT. Otherwise, the operation is not guaranteed.
  5. The CnGMABTD register is used to set the delay time that is inserted in the period from completion of the preceding ABT message to setting of the TRQ bit for the next ABT message when the transmission requests are set in the order of message numbers for each message for ABT that is successively transmitted in the ABT mode. The timing at which the messages are actually transmitted onto the CAN bus varies depending on the status of transmission from other stations and the status of the setting of the transmission request for messages other than the ABT messages (message buffers 8 to 31).
  6. If a transmission request is made for a message other than an ABT message and if no delay time is inserted in the interval in which transmission requests for ABT are automatically set (CnGMABTD register = 00H), messages other than ABT messages may be transmitted regardless of their priority in regards to the ABT message.
  7. Do not clear the RDY bit to 0 when the ABTTRG bit = 1.
  8. If a message is received from another node in the normal operation mode with ABT, the message may be transmitted after the time of one frame has elapsed even when CnGMABTD register = 00H.

**Remark** n = 0, 1  
m = 00 to 31

### 21.10.4 Transmission abort process

**Remark** n = 0, 1  
m = 00 to 31

**(1) Transmission abort process other than in normal operation mode with automatic block transmission (ABT)**

The user can clear the CnMCTRLm.TRQ bit to 0 to abort a transmission request. The TRQ bit will be cleared immediately if the abort was successful. Whether the transmission was successfully aborted or not can be checked using the CnCTRL.TSTAT bit and the CnTGPT register, which indicate the transmission status on the CAN bus (for details, refer to the processing in **Figure 21-46**).

**(2) Transmission abort process except for ABT transmission in normal operation mode with automatic block transmission (ABT)**

The user can clear the CnGMABT.ABTTRG bit to 0 to abort a transmission request. After checking the ABTTRG bit of the CnGMABT register = 0, clear the CnMCTRLm.TRQ bit to 0. The TRQ bit will be cleared immediately if the abort was successful. Whether the transmission was successfully aborted or not can be checked by using the CnCTRL.TSTAT bit and the CnTGPT register, which indicate the transmission status on the CAN bus (for details, refer to the process in **Figure 21-47**).

**(3) Transmission abort in normal operation mode with automatic block transmission (ABT)**

To abort ABT that is already started, clear the CnGMABT.ABTTRG bit to 0. In this case, the ABTTRG bit remains 1 if an ABT message is currently being transmitted and until the transmission is completed (successfully or not), and is cleared to 0 as soon as transmission is finished. This aborts ABT.

If the last transmission (before ABT) was successful, the normal operation mode with ABT is left with the internal ABT pointer pointing to the next message buffer to be transmitted.

In the case of an erroneous transmission, the position of the internal ABT pointer depends on the status of the TRQ bit in the last transmitted message buffer. If the TRQ bit is set to 1 when clearing the ABTTRG bit is requested, the internal ABT pointer points to the last transmitted message buffer (for details, refer to the process in **Figure 21-48 (a)**). If the TRQ bit is cleared to 0 when clearing the ABTTRG bit is requested, the internal ABT pointer is increased in increments of 1 and indicates the next message buffer in the ABT area (for details, refer to the process in **Figure 21-48 (b)**).

**Caution** Be sure to abort ABT by clearing the ABTTRG bit to 0. The operation is not guaranteed if aborting transmission is requested by clearing RDY.

When the normal operation mode with ABT is resumed after ABT has been aborted and the ABTTRG bit is set to 1, the next ABT message buffer to be transmitted can be determined from the following table.

Status of TRQ of ABT Message Buffer	Abort After Successful Transmission	Abort After Erroneous Transmission
Set (1)	Next message buffer in the ABT area <sup>Note</sup>	Same message buffer in the ABT area
Cleared (0)	Next message buffer in the ABT area <sup>Note</sup>	Next message buffer in the ABT area <sup>Note</sup>

**Note** The above resumption operation can be performed only if a message buffer ready for ABT exists in the ABT area. For example, an abort request that is issued while ABT of message buffer 7 is in progress is regarded as completion of ABT, rather than abort, if transmission of message buffer 7 has been successfully completed, even if the ABTTRG bit is cleared to 0. If the CnMCTRLm.RDY bit in the next message buffer in the ABT area is cleared to 0, the internal ABT pointer is retained, but the resumption operation is not performed even if the ABTTRG bit is set to 1, and ABT ends immediately.

**Remark** n = 0, 1  
m = 00 to 31

### 21.10.5 Remote frame transmission

Remote frames can be transmitted only from transmit message buffers. Set whether a data frame or remote frame is transmitted via the CnMCONFm.RTR bit. Setting (1) the RTR bit sets remote frame transmission.

**Remark** n = 0, 1  
m = 00 to 31

## 21.11 Power Saving Modes

### 21.11.1 CAN sleep mode

The CAN sleep mode can be used to set the CAN controller to standby mode in order to reduce power consumption. The CAN module can enter the CAN sleep mode from all operation modes. Release of the CAN sleep mode returns the CAN module to exactly the same operation mode from which the CAN sleep mode was entered.

In the CAN sleep mode, the CAN module does not transmit messages, even when transmission requests are issued or pending.

#### (1) Entering CAN sleep mode

The CPU issues a CAN sleep mode transition request by writing 01B to the CnCTRL.PSMODE1 and CnCTRL.PSMODE0 bits.

This transition request is only acknowledged only under the following conditions.

**Remark** n = 0, 1

(i) The CAN module is already in one of the following operation modes

- Normal operation mode
- Normal operation mode with ABT
- Receive-only mode
- Single-shot mode
- Self-test mode
- CAN stop mode in all the above operation modes

(ii) The CAN bus state is bus idle (the 4th bit in the interframe space is recessive)<sup>Note</sup>

**Note** If the CAN bus is fixed to dominant, the request for transition to the CAN sleep mode is held pending. Also the transition from CAN stop mode to CAN sleep mode is independent of the CAN bus state.

(iii) No transmission request is pending

If any one of the conditions mentioned above is not met, the CAN module will operate as follows.

- If the CAN sleep mode is requested from the initialization mode, the CAN sleep mode transition request is ignored and the CAN module remains in the initialization mode.
- If the CAN bus state is not bus idle (i.e., the CAN bus state is either transmitting or receiving) when the CAN sleep mode is requested in one of the operation modes, immediate transition to the CAN sleep mode is not possible. In this case, the CAN sleep mode transition request has to be held pending until the CAN bus state becomes bus idle (the 4th bit in the interframe space is recessive). In the time from the CAN sleep mode request to successful transition, the PSMODE1 and PSMODE0 bits remain 00B. When the module has entered the CAN sleep mode, the PSMODE1 and PSMODE0 bits are set to 01B.
- If a request for transition to the initialization mode and a request for transition to the CAN sleep mode are made at the same time while the CAN module is in one of the operation modes, the request for the initialization mode is enabled. The CAN module enters the initialization mode at a predetermined timing. At this time, the CAN sleep mode request is not held pending and is ignored.
- Even when the initialization mode and sleep mode are not requested simultaneously (i.e the first request was not granted when a second request was made), the request for initialization has priority over the CAN sleep mode request. The CAN sleep mode request is cancelled when the initialization mode is requested. When a pending request for the initialization mode is present, a subsequent request for the CAN sleep mode request is cancelled right at the point in time when it was submitted.

**(2) Status in CAN sleep mode**

The CAN module is in one of the following states after it enters the CAN sleep mode.

- The internal operating clock is stopped and the power consumption is minimized.
- The function to detect the falling edge of the CAN reception pin (CRXDn) remains in effect to wake up the CAN module from the CAN bus.
- To wake up the CAN module from the CPU, data can be written to the PSMODE1 and PSMODE0 bits, but nothing can be written to other CANn module registers or bits.
- The CANn module registers can be read, except for the CnLIPT, CnRGPT, CnLOPT, and CnTGPT registers.
- The CANn message buffer registers cannot be written or read.
- CnGMCTRL.MBON bit is cleared to 0.
- A request for transition to the initialization mode is not acknowledged and is ignored.

**Remark** n = 0, 1

**(3) Releasing CAN sleep mode**

The CAN sleep mode is released by the following events.

- When the CPU writes 00B to the PSMODE1 and PSMODE0 bits
- A falling edge at the CAN reception pin (CRXDn) (i.e. the CAN bus level shifts from recessive to dominant)

**Cautions** 1. **Even if the falling edge belongs to the SOF of a receive message, this message will not be received and stored. If the CPU has turned off the clock to the CAN while the CAN was in sleep mode, later on the CAN sleep mode will not be released and PSMODE[1:0] bits will continue to be 01B unless the clock for the CAN is provided again. In addition to this, the receive message will not be received afterwards.**

2. **If a falling edge is detected at the CAN reception pin (CRXDn) while the CAN clock is supplied, the PSMODE0 bit must be cleared by software. (For details, refer to the processing in Figure 21-53.)**

After releasing the sleep mode, the CAN module returns to the operation mode from which the CAN sleep mode was requested and the PSMODE1 and PSMODE0 bits are reset to 00B. If the CAN sleep mode is released by a change in the CAN bus state, the CnINTS.CINTS5 bit is set to 1, regardless of the CnIE.CIE bit. After the CAN module is released from the CAN sleep mode, it participates in the CAN bus again by automatically detecting 11 consecutive recessive-level bits on the CAN bus. After releasing the sleep mode and before accessing the message buffer by application again, confirm that CnGMCTRL.MBON bit = 1.

When a request for transition to the initialization mode is made while the CAN module is in the CAN sleep mode, that request is ignored; the CPU has to be released from sleep mode by software first before entering the initialization mode.

**Caution** **When the CAN sleep mode is released by an event of the CAN bus, a wakeup interrupt occurs even if the event of the CAN bus occurs immediately after the mode has been changed to the sleep mode. Note that the interrupt can occur at any time.**

**Remark** n = 0, 1



### 21.11.2 CAN stop mode

The CAN stop mode can be used to set the CAN controller to standby mode to reduce power consumption. The CAN module can enter the CAN stop mode only from the CAN sleep mode. Release of the CAN stop mode puts the CAN module in the CAN sleep mode.

The CAN stop mode can only be released (shifting to CAN sleep mode) by writing 01B to the CnCTRL.PSMODE1 and CnCTRL.PSMODE0 bits and not by a change in the CAN bus state. No message is transmitted even when transmission requests are issued or pending.

**Remark** n = 0, 1

#### (1) Entering CAN stop mode

A CAN stop mode transition request is issued by writing 11B to the PSMODE1 and PSMODE0 bits.

A CAN stop mode request is only acknowledged when the CAN module is in the CAN sleep mode. In all other modes, the request is ignored.

**Caution** To set the CAN module to the CAN stop mode, the module must be in the CAN sleep mode. To confirm that the module is in the sleep mode, check that the PSMODE1 and PSMODE0 bits = 01B, and then request the CAN stop mode. If a bus change occurs at the CAN reception pin (CRXDn) while this process is being performed, the CAN sleep mode is automatically released. In this case, the CAN stop mode transition request cannot be acknowledged (while the CAN clock is supplied, however, the PSMODE0 must be cleared by software after the bus level of the CAN reception pin (CRXDn) is changed).

#### (2) Status in CAN stop mode

The CAN module is in one of the following states after it enters the CAN stop mode.

- The internal operating clock is stopped and the power consumption is minimized.
- To wake up the CAN module from the CPU, data can be written to the PSMODE1 and PSMODE0 bits, but nothing can be written to other CANn module registers or bits.
- The CANn module registers can be read, except for the CnLIPT, CnRGPT, CnLOPT, and CnTGPT registers.
- The CANn message buffer registers cannot be written or read.
- The CnGMCTRL.MBON bit is cleared to 0.
- An initialization mode transition request is not acknowledged and is ignored.

#### (3) Releasing CAN stop mode

The CAN stop mode can only be released by writing 01B to the PSMODE1 and PSMODE0 bits. After releasing the CAN stop mode, the CAN module enters the CAN sleep mode.

When the initialization mode is requested while the CAN module is in the CAN stop mode, that request is ignored; the CPU has to release the stop mode and subsequently the CAN sleep mode before entering into initialization mode. It is impossible to enter another operation mode directly from the CAN stop mode without entering the CAN sleep mode, the request will be ignored.

### 21.11.3 Example of using power saving modes

In some application systems, it may be necessary to place the CPU in a power saving mode to reduce the power consumption. By using the power saving mode specific to the CAN module and the power saving mode specific to the CPU in combination, the CPU can be woken up from the power saving status by the CAN bus.

Here is an example of using the power saving modes.

First, put the CAN module in the CAN sleep mode (PSMODE1, PSMODE0 bits = 01B). Next, put the CPU in the power saving mode. If an edge transition from recessive to dominant is detected at the CRXDn signal in this status, the CINTS5 bit in the CAN module is set to 1. If the CnCTRL.CIE5 bit is set to 1, a wakeup interrupt (INTCnWUP) is generated. The CAN module is automatically released from the CAN sleep mode (PSMODE1, PSMODE0 bits = 00B) and returns to normal operation mode (while the CAN clock is supplied, however, the PSMODE0 must be cleared by software after a bus level change is detected at the CAN reception pin (CRXDn). ). The CPU, in response to INTCnWUP, can release its own power saving mode and return to normal operation mode.

To further reduce the power consumption of the CPU, the internal clocks, including that of the CAN module, may be tuned off. In this case, the operating clock supplied to the CAN module is turned off after the CAN module is put in the CAN sleep mode. Then the CPU enters a power saving mode in which the clock supplied to the CPU is turned off. If an edge transition from recessive to dominant is detected at the CRXDn signal in this status, the CAN module can set the CINTS5 bit to 1 and generate a wakeup interrupt (INTCnWUP) even if it is not supplied with a clock. The other functions, however, do not operate because the clock supply to the CAN module is shut off, and the module remains in the CAN sleep mode. The CPU, in response to INTCnWUP, releases its power saving mode, resumes supply of the internal clocks, including the clock to the CAN module, after oscillation stabilization time has elapsed, and starts instruction execution. The CAN module is immediately released from the CAN sleep mode when the clock supply is resumed, and returns to normal operation mode (PSMODE1, PSMODE0 bits = 00B).

**Remark** n = 0, 1

## 21.12 Interrupt Function

The CAN module provides 6 different interrupt sources.

The occurrence of these interrupt sources is stored in interrupt status registers. Four separate interrupt request signals are generated from the six interrupt sources. When an interrupt request signal that corresponds to two or more interrupt sources is generated, the interrupt sources can be identified by using an interrupt status register. After an interrupt source has occurred, the corresponding interrupt status bit must be cleared to 0 by software.

**Table 21-20. List of CAN Module Interrupt Sources**

No.	Interrupt Status Bit		Interrupt Enable Bit		Interrupt Request Signal	Interrupt Source Description
	Name	Register	Name	Register		
1	CINTS0 <sup>Note 1</sup>	CnINTS	CIE0 <sup>Note 1</sup>	CnIE	INTCnTRX	Message frame successfully transmitted from message buffer m
2	CINTS1 <sup>Note 1</sup>	CnINTS	CIE1 <sup>Note 1</sup>	CnIE	INTCnREC	Valid message frame reception in message buffer m
3	CINTS2	CnINTS	CIE2	CnIE	INTCnERR	CAN module error state interrupt <sup>Note 2</sup>
4	CINTS3	CnINTS	CIE3	CnIE		CAN module protocol error interrupt <sup>Note 3</sup>
5	CINTS4	CnINTS	CIE4	CnIE		CAN module arbitration loss interrupt
6	CINTS5	CnINTS	CIE5	CnIE	INTCnWUP	CAN module wakeup interrupt from CAN sleep mode <sup>Note 4</sup>

- Notes**
1. The CnMCTRL.IE bit (message buffer interrupt enable bit) of the corresponding message buffer has to be set to 1 for that message buffer to participate in the interrupt generation process.
  2. This interrupt is generated when the transmission/reception error counter is at the warning level, or in the error passive or bus-off state.
  3. This interrupt is generated when a stuff error, form error, ACK error, bit error, or CRC error occurs.
  4. This interrupt is generated when the CAN module is woken up from the CAN sleep mode because a falling edge is detected at the CAN reception pin (CAN bus transition from recessive to dominant).

**Remark** n = 0, 1  
m = 00 to 31

### 21.13 Diagnosis Functions and Special Operational Modes

The CAN module provides a receive-only mode, single-shot mode, and self-test mode to support CAN bus diagnosis functions or the operation of special CAN communication methods.

#### 21.13.1 Receive-only mode

The receive-only mode is used to monitor receive messages without causing any interference on the CAN bus and can be used for CAN bus analysis nodes.

For example, this mode can be used for automatic baud-rate detection. The baud rate in the CAN module is changed until “valid reception” is detected, so that the baud rates in the module match (“valid reception” means a message frame has been received in the CAN protocol layer without occurrence of an error and with an appropriate ACK between nodes connected to the CAN bus). A valid reception does not require message frames to be stored in a receive message buffer (data frames) or transmit message buffer (remote frames). The event of valid reception is indicated by setting the CnCTRL.VALID bit (1).

**Figure 21-33. CAN Module Terminal Connection in Receive-Only Mode**

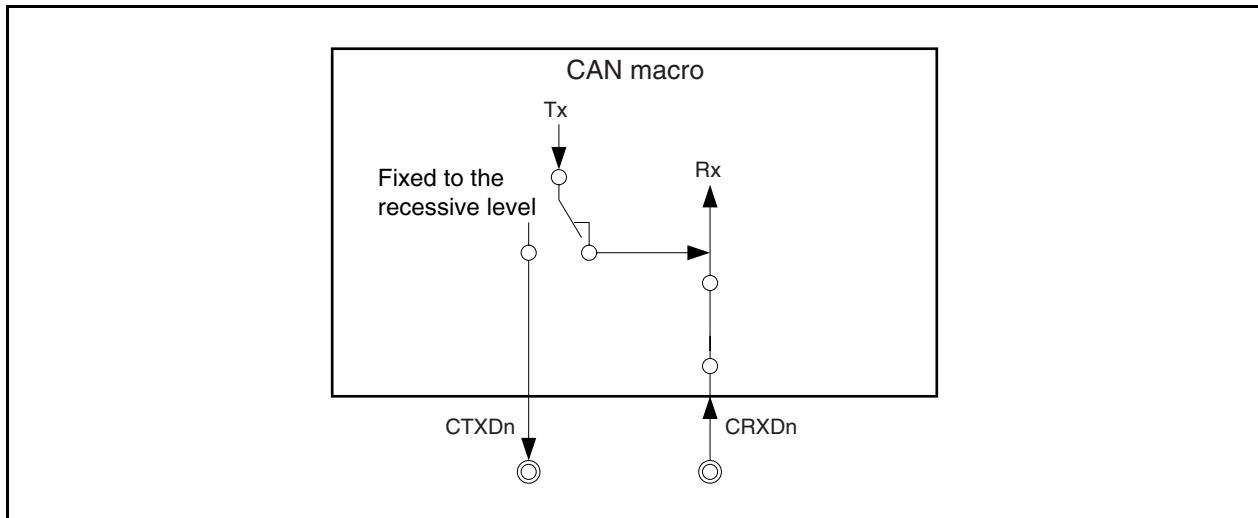

In the receive-only mode, no message frames can be transmitted from the CAN module to the CAN bus. Transmit requests issued for message buffers defined as transmit message buffers are held pending.

In the receive-only mode, the CAN transmission pin (CTXDn) in the CAN module is fixed to the recessive level. Therefore, no active error flag can be transmitted from the CAN module to the CAN bus even when a CAN bus error is detected while receiving a message frame. Since no transmission can be issued from the CAN module, the transmission error counter the CnERC.TEC7 to CnERC.TEC0 bits are never updated. Therefore, a CAN module in the receive-only mode does not enter the bus-off state.

Furthermore, ACK is not returned to the CAN bus in this mode upon the valid reception of a message frame. Internally, the local node recognizes that it has transmitted ACK. An overload frame cannot be transmitted to the CAN bus.

**Caution** If only two CAN nodes are connected to the CAN bus and one of them is operating in the receive-only mode, there is no ACK on the CAN bus. Due to the missing ACK, the transmitting node will transmit an active error flag, and repeat transmitting a message frame. The transmitting node becomes error passive after transmitting the message frame 16 times (assuming that the error counter was 0 in the beginning and no other errors have occurred). When the message frame is transmitted for the 17th time, the transmitting node generates a passive error flag. The receiving node in the receive-only mode detects the first valid message frame at this point, and the VALID bit is set to 1 for the first time.

**Remark** n = 0, 1

### 21.13.2 Single-shot mode

In the single-shot mode, automatic re-transmission as defined in the CAN protocol is switched off. (According to the CAN protocol, a message frame transmission that has been aborted by either arbitration loss or error occurrence has to be repeated without control by software.) All other behavior of single-shot mode is identical to normal operation mode. Features of single-shot mode can not be used in combination with normal mode with ABT.

The single-shot mode disables the re-transmission of an aborted message frame transmission according to the setting of the CnCTRL.AL bit. When the AL bit is cleared to 0, re-transmission upon arbitration loss and upon error occurrence is disabled. If the AL bit is set to 1, re-transmission upon error occurrence is disabled, but re-transmission upon arbitration loss is enabled. As a consequence, the CnMCTRLm.TRQ bit in a message buffer defined as a transmit message buffer is cleared to 0 by the following events.

- Successful transmission of the message frame
- Arbitration loss while sending the message frame (AL bit = 0)
- Error occurrence while sending the message frame

The events arbitration loss and error occurrence can be distinguished by checking the CnINTS.CINTS4 and CnINTS.CINTS3 bits, and the type of the error can be identified by reading the CnLEC.LEC2 to CnLEC.LEC0 bits of the register.

Upon successful transmission of the message frame, the transmit completion interrupt the CINTS0 bit of the CnINTS register is set to 1. If the CnIE.CIE0 bit is set to 1 at this time, an interrupt request signal is output.

The single-shot mode can be used when emulating time-triggered communication methods (e.g., TTCAN level 1).

**Caution** The AL bit is only valid in single-shot mode. It does not affect the operation of re-transmission upon arbitration loss in other operation modes.

**Remark** n = 0, 1

### 21.13.3 Self-test mode

In the self-test mode, message frame transmission and message frame reception can be tested without connecting the CAN node to the CAN bus or without affecting the CAN bus.

In the self-test mode, the CAN module is completely disconnected from the CAN bus, but transmission and reception are internally looped back. The CAN transmission pin (CTXDn) is fixed to the recessive level.

If the falling edge on the CAN reception pin (CRXDn) is detected after the CAN module has entered the CAN sleep mode from the self-test mode, however, the module is released from the CAN sleep mode in the same manner as the other operation modes (when the sleep mode is released while the CAN clock is supplied, however, the PSMODE0 bit must be cleared by software after a falling edge is detected at the CAN reception pin (CRXDn).). To keep the module in the CAN sleep mode, use the CAN reception pin (CRXDn) as a port pin.

**Remark** n = 0, 1

**Figure 21-34. CAN Module Terminal Connection in Self-Test Mode**

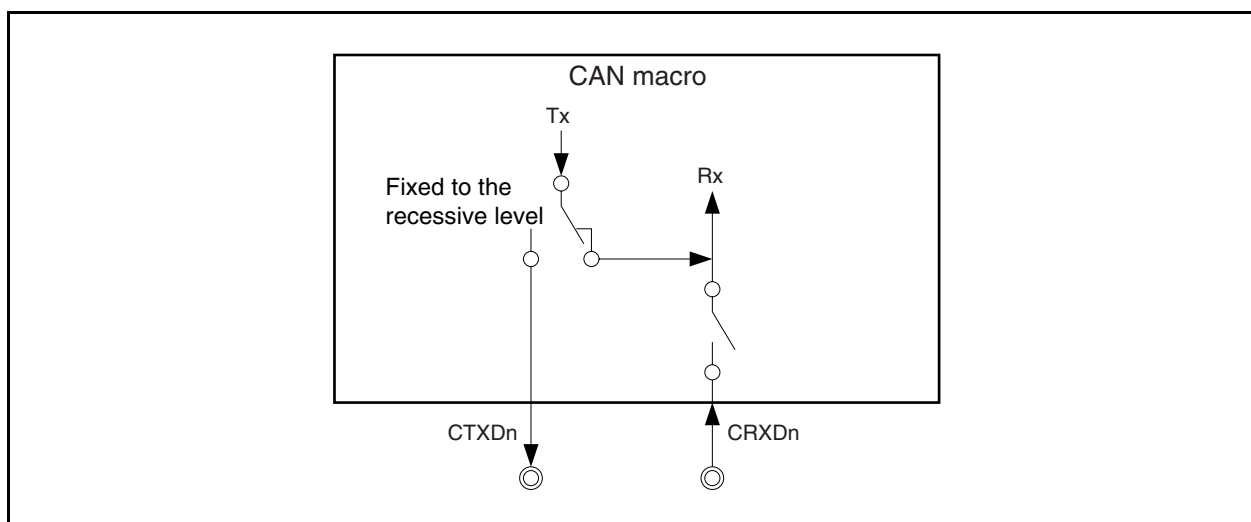

### 21.13.4 Transmission/reception operation in each operation mode

Table 21-21 shows the transmission/reception operation in each operation mode.

**Table 21-21. Overview of Transmission/Reception Operation in Each Operation Mode**

Operation Mode	Data Frame/ Remote Frame Transmission	ACK Transmission	Error Frame/ Overload Frame Transmission	Retransmission	Automatic Block Transmission (ABT)	Setting of VALID Bit	Storing Data in Message Buffer
Initialization Mode	–	–	–	–	–	–	–
Normal operation mode	√	√	√	√	–	√	√
Normal operation mode with ABT	√	√	√	√	√	√	√
Receive-only mode	–	–	–	–	–	√	√
Single-shot mode	√	√	√	– <sup>Note 1</sup>	–	√	√
Self test mode	√ <sup>Note 2</sup>	√ <sup>Note 2</sup>	√ <sup>Note 2</sup>	√ <sup>Note 2</sup>	–	√ <sup>Note 2</sup>	√ <sup>Note 2</sup>

- Notes**
1. If arbitration is lost, retransmission can be selected by the CnCTRL.AL bit.
  2. Each signal is not output to the external circuit but is internally generated by the CAN module.

## 21.14 Time Stamp Function

CAN is an asynchronous, serial protocol. All nodes connected to the CAN bus have a local, autonomous clock. As a consequence, the clocks of the nodes have no relation (i.e., the clocks are asynchronous and may even have different frequencies).

In some applications, however, a common time base over the network (= global time base) is needed. In order to build up a global time base, a time stamp function is used. The essential mechanism of a time stamp function is the capture of timer values triggered by signals on the CAN bus.

### 21.14.1 Time stamp function

The CAN controller supports the capturing of timer values triggered by a specific frame. An on-chip 16-bit capture timer unit in a microcontroller system is used in addition to the CAN controller. The 16-bit capture timer unit captures the timer value according to a trigger signal (TSOUT) for capturing that is output when a data frame is received from the CAN controller. The CPU can retrieve the time of occurrence of the capture event, i.e., the time stamp of the message received from the CAN bus, by reading the captured value. The TSOUT signal can be selected from the following two event sources and is specified by the CnTS.TSSEL bit.

- SOF event (start of frame) (TSSEL bit = 0)
- EOF event (last bit of end of frame) (TSSEL bit = 1)

The TSOUT signal is enabled by setting the CnTS.TSEN bit to 1.

**Figure 21-35. Timing Diagram of Capture Signal TSOUT**

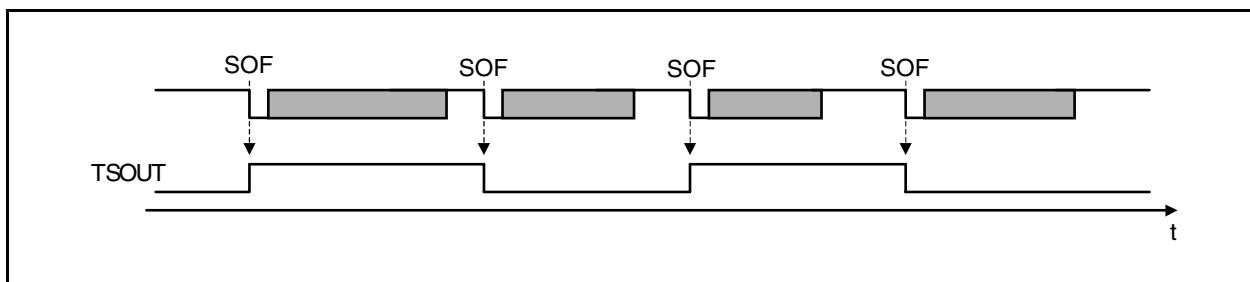

The TSOUT signal toggles its level upon occurrence of the selected event during data frame reception (in Figure 21-34, the SOF is used as the trigger event source). To capture a timer value by using the TSOUT signal, the capture timer unit must detect the capture signal at both the rising edge and falling edge.

This time stamp function is controlled by the CnTS.TSLOCK bit. When the TSLOCK bit is cleared to 0, the TSOUT signal toggles upon occurrence of the selected event. If the TSLOCK bit is set to 1, the TSOUT signal toggles upon occurrence of the selected event, but the toggle is stopped as the TSEN bit is automatically cleared to 0 when a data frame starts to be received and stored in message buffer 0. This suppresses the subsequent toggle occurrence by the TSOUT signal, so that the time stamp value toggled last (= captured last) can be saved as the time stamp value of the time at which the data frame was received in message buffer 0.



**Caution** The time stamp function using the TSLOCK bit stops toggle of the TSOUT signal by receiving a data frame in message buffer 0. Therefore, message buffer 0 must be set as a receive message buffer. Since a receive message buffer cannot receive a remote frame, toggle of the TSOUT signal cannot be stopped by reception of a remote frame. Toggle of the TSOUT signal does not stop when a data frame is received in a message buffer other than message buffer 0.

For these reasons, a data frame cannot be received in message buffer 0 when the CAN module is in the normal operation mode with ABT, because message buffer 0 must be set as a transmit message buffer. In this operation mode, therefore, the function to stop toggle of the TSOUT signal by the TSLOCK bit cannot be used.

**Remark** n = 0, 1

## 21.15 Baud Rate Settings

### 21.15.1 Bit rate setting conditions

Make sure that the settings are within the range of limit values for ensuring correct operation of the CAN controller, as follows.

- (a)  $5TQ \leq SPT$  (sampling point)  $\leq 17 TQ$   
 $SPT = TSEG1 + 1TQ$
- (b)  $8 TQ \leq DBT$  (data bit time)  $\leq 25 TQ$   
 $DBT = TSEG1 + TSEG2 + 1TQ = TSEG2 + SPT$
- (c)  $1 TQ \leq SJW$  (synchronization jump width)  $\leq 4TQ$   
 $SJW \leq DBT - SPT$
- (d)  $4TQ \leq TSEG1 \leq 16TQ$  [ $3 \leq$  Setting value of  $TSEG1[3:0] \leq 15$ ]
- (e)  $1TQ \leq TSEG2 \leq 8TQ$  [ $0 \leq$  Setting value of  $TSEG2[2:0] \leq 7$ ]

**Remark**  $TQ = 1/f_{TQ}$  ( $f_{TQ}$ : CAN protocol layer base system clock)  
 $TSEG1[3:0]$  (CnBTR.TSEG13 to CnBTR.TSEG10 bits) ( $n = 0, 1$ )  
 $TSEG2[2:0]$  (CnBTR.TSEG22 to CnBTR.TSEG20 bits) ( $n = 0, 1$ )

Table 21-22 shows the combinations of bit rates that satisfy the above conditions.

Table 21-22. Settable Bit Rate Combinations (1/3)

DBT Length	Valid Bit Rate Setting				CnBTR Register Setting Value		Sampling Point (Unit: %)
	SYNC SEGMENT	PROP SEGMENT	PHASE SEGMENT1	PHASE SEGMENT2	TSEG13 to TSEG10	TSEG22 to TSEG20	
25	1	8	8	8	1111	111	68.0
24	1	7	8	8	1110	111	66.7
24	1	9	7	7	1111	110	70.8
23	1	6	8	8	1101	111	65.2
23	1	8	7	7	1110	110	69.6
23	1	10	6	6	1111	101	73.9
22	1	5	8	8	1100	111	63.6
22	1	7	7	7	1101	110	68.2
22	1	9	6	6	1110	101	72.7
22	1	11	5	5	1111	100	77.3
21	1	4	8	8	1011	111	61.9
21	1	6	7	7	1100	110	66.7
21	1	8	6	6	1101	101	71.4
21	1	10	5	5	1110	100	76.2
21	1	12	4	4	1111	011	81.0
20	1	3	8	8	1010	111	60.0
20	1	5	7	7	1011	110	65.0
20	1	7	6	6	1100	101	70.0
20	1	9	5	5	1101	100	75.0
20	1	11	4	4	1110	011	80.0
20	1	13	3	3	1111	010	85.0
19	1	2	8	8	1001	111	57.9
19	1	4	7	7	1010	110	63.2
19	1	6	6	6	1011	101	68.4
19	1	8	5	5	1100	100	73.7
19	1	10	4	4	1101	011	78.9
19	1	12	3	3	1110	010	84.2
19	1	14	2	2	1111	001	89.5
18	1	1	8	8	1000	111	55.6
18	1	3	7	7	1001	110	61.1
18	1	5	6	6	1010	101	66.7
18	1	7	5	5	1011	100	72.2
18	1	9	4	4	1100	011	77.8
18	1	11	3	3	1101	010	83.3
18	1	13	2	2	1110	001	88.9
18	1	15	1	1	1111	000	94.4

**Remark** n = 0, 1

Table 21-22. Settable Bit Rate Combinations (2/3)

DBT Length	Valid Bit Rate Setting				CnBTR Register Setting Value		Sampling Point (Unit: %)
	SYNC SEGMENT	PROP SEGMENT	PHASE SEGMENT1	PHASE SEGMENT2	TSEG13 to TSEG10	TSEG22 to TSEG20	
17	1	2	7	7	1000	110	58.8
17	1	4	6	6	1001	101	64.7
17	1	6	5	5	1010	100	70.6
17	1	8	4	4	1011	011	76.5
17	1	10	3	3	1100	010	82.4
17	1	12	2	2	1101	001	88.2
17	1	14	1	1	1110	000	94.1
16	1	1	7	7	0111	110	56.3
16	1	3	6	6	1000	101	62.5
16	1	5	5	5	1001	100	68.8
16	1	7	4	4	1010	011	75.0
16	1	9	3	3	1011	010	81.3
16	1	11	2	2	1100	001	87.5
16	1	13	1	1	1101	000	93.8
15	1	2	6	6	0111	101	60.0
15	1	4	5	5	1000	100	66.7
15	1	6	4	4	1001	011	73.3
15	1	8	3	3	1010	010	80.0
15	1	10	2	2	1011	001	86.7
15	1	12	1	1	1100	000	93.3
14	1	1	6	6	0110	101	57.1
14	1	3	5	5	0111	100	64.3
14	1	5	4	4	1000	011	71.4
14	1	7	3	3	1001	010	78.6
14	1	9	2	2	1010	001	85.7
14	1	11	1	1	1011	000	92.9
13	1	2	5	5	0110	100	61.5
13	1	4	4	4	0111	011	69.2
13	1	6	3	3	1000	010	76.9
13	1	8	2	2	1001	001	84.6
13	1	10	1	1	1010	000	92.3
12	1	1	5	5	0101	100	58.3
12	1	3	4	4	0110	011	66.7
12	1	5	3	3	0111	010	75.0
12	1	7	2	2	1000	001	83.3
12	1	9	1	1	1001	000	91.7

**Remark** n = 0, 1

Table 21-22. Settable Bit Rate Combinations (3/3)

DBT Length	Valid Bit Rate Setting				CnBTR Register Setting Value		Sampling Point (Unit: %)
	SYNC SEGMENT	PROP SEGMENT	PHASE SEGMENT1	PHASE SEGMENT2	TSEG13 to TSEG10	TSEG22 to TSEG20	
11	1	2	4	4	0101	011	63.6
11	1	4	3	3	0110	010	72.7
11	1	6	2	2	0111	001	81.8
11	1	8	1	1	1000	000	90.9
10	1	1	4	4	0100	011	60.0
10	1	3	3	3	0101	010	70.0
10	1	5	2	2	0110	001	80.0
10	1	7	1	1	0111	000	90.0
9	1	2	3	3	0100	010	66.7
9	1	4	2	2	0101	001	77.8
9	1	6	1	1	0110	000	88.9
8	1	1	3	3	0011	010	62.5
8	1	3	2	2	0100	001	75.0
8	1	5	1	1	0101	000	87.5
7 <sup>Note</sup>	1	2	2	2	0011	001	71.4
7 <sup>Note</sup>	1	4	1	1	0100	000	85.7
6 <sup>Note</sup>	1	1	2	2	0010	001	66.7
6 <sup>Note</sup>	1	3	1	1	0011	000	83.3
5 <sup>Note</sup>	1	2	1	1	0010	000	80.0
4 <sup>Note</sup>	1	1	1	1	0001	000	75.0

**Note** Setting with a DBT value of 7 or less is valid only when the value of the CnBRP register is other than 00H.

**Caution** The values in Table 21-22 do not guarantee the operation of the network system. Thoroughly check the effect on the network system, taking into consideration oscillation errors and delays of the CAN bus and CAN transceiver.

**Remark** n = 0, 1

## 21.15.2 Representative examples of baud rate settings

Tables 21-23 and 21-24 show representative examples of baud rate settings.

**Table 21-23. Representative Examples of Baud Rate Settings ( $f_{CANMOD} = 8\text{ MHz}$ ) (1/2)**

Set Baud Rate Value (Unit: kbps)	Division Ratio of CnBRP Register	CnBRP Register Set Value	Valid Bit Rate Setting (Unit: kbps)					CnBTR Register Setting Value		Sampling Point (Unit: %)
			Length of DBT	SYNC SEGMENT	PROP SEGMENT	PHASE SEGMENT1	PHASE SEGMENT2	TSEG13 to TSEG10	TSEG22 to TSEG20	
1000	1	00000000	8	1	1	3	3	0011	010	62.5
1000	1	00000000	8	1	3	2	2	0100	001	75.0
1000	1	00000000	8	1	5	1	1	0101	000	87.5
500	1	00000000	16	1	1	7	7	0111	110	56.3
500	1	00000000	16	1	3	6	6	1000	101	62.5
500	1	00000000	16	1	5	5	5	1001	100	68.8
500	1	00000000	16	1	7	4	4	1010	011	75.0
500	1	00000000	16	1	9	3	3	1011	010	81.3
500	1	00000000	16	1	11	2	2	1100	001	87.5
500	1	00000000	16	1	13	1	1	1101	000	93.8
500	2	00000001	8	1	1	3	3	0011	010	62.5
500	2	00000001	8	1	3	2	2	0100	001	75.0
500	2	00000001	8	1	5	1	1	0101	000	87.5
250	2	00000001	16	1	1	7	7	0111	110	56.3
250	2	00000001	16	1	3	6	6	1000	101	62.5
250	2	00000001	16	1	5	5	5	1001	100	68.8
250	2	00000001	16	1	7	4	4	1010	011	75.0
250	2	00000001	16	1	9	3	3	1011	010	81.3
250	2	00000001	16	1	11	2	2	1100	001	87.5
250	2	00000001	16	1	13	1	1	1101	000	93.8
250	4	00000011	8	1	3	2	2	0100	001	75.0
250	4	00000011	8	1	5	1	1	0101	000	87.5
125	4	00000011	16	1	1	7	7	0111	110	56.3
125	4	00000011	16	1	3	6	6	1000	101	62.5
125	4	00000011	16	1	5	5	5	1001	100	68.8
125	4	00000011	16	1	7	4	4	1010	011	75.0
125	4	00000011	16	1	9	3	3	1011	010	81.3
125	4	00000011	16	1	11	2	2	1100	001	87.5
125	4	00000011	16	1	13	1	1	1101	000	93.8
125	8	00000111	8	1	3	2	2	0100	001	75.0
125	8	00000111	8	1	5	1	1	0101	000	87.5

**Caution** The values in Table 21-23 do not guarantee the operation of the network system. Thoroughly check the effect on the network system, taking into consideration oscillation errors and delays of the CAN bus and CAN transceiver.

**Remark** n = 0, 1

Table 21-23. Representative Examples of Baud Rate Settings ( $f_{CANMOD} = 8 \text{ MHz}$ ) (2/2)

Set Baud Rate Value (Unit: kbps)	Division Ratio of CnBRP Register	CnBRP Register Set Value	Valid Bit Rate Setting (Unit: kbps)					CnBTR Register Setting Value		Sampling Point (Unit: %)
			Length of DBT	SYNC SEGMENT	PROP SEGMENT	PHASE SEGMENT1	PHASE SEGMENT2	TSEG13 to TSEG10	TSEG22 to TSEG20	
100	4	00000011	20	1	7	6	6	1100	101	70.0
100	4	00000011	20	1	9	5	5	1101	100	75.0
100	5	00000100	16	1	7	4	4	1010	011	75.0
100	5	00000100	16	1	9	3	3	1011	010	81.3
100	8	00000111	10	1	3	3	3	0101	010	70.0
100	8	00000111	10	1	5	2	2	0110	001	80.0
100	10	00001001	8	1	3	2	2	0100	001	75.0
100	10	00001001	8	1	5	1	1	0101	000	87.5
83.3	4	00000011	24	1	7	8	8	1110	111	66.7
83.3	4	00000011	24	1	9	7	7	1111	110	70.8
83.3	6	00000101	16	1	5	5	5	1001	100	68.8
83.3	6	00000101	16	1	7	4	4	1010	011	75.0
83.3	6	00000101	16	1	9	3	3	1011	010	81.3
83.3	6	00000101	16	1	11	2	2	1100	001	87.5
83.3	8	00000111	12	1	5	3	3	0111	010	75.0
83.3	8	00000111	12	1	7	2	2	1000	001	83.3
83.3	12	00001011	8	1	3	2	2	0100	001	75.0
83.3	12	00001011	8	1	5	1	1	0101	000	87.5
33.3	10	00001001	24	1	7	8	8	1110	111	66.7
33.3	10	00001001	24	1	9	7	7	1111	110	70.8
33.3	12	00001011	20	1	7	6	6	1100	101	70.0
33.3	12	00001011	20	1	9	5	5	1101	100	75.0
33.3	15	00001110	16	1	7	4	4	1010	011	75.0
33.3	15	00001110	16	1	9	3	3	1011	010	81.3
33.3	16	00001111	15	1	6	4	4	1001	011	73.3
33.3	16	00001111	15	1	8	3	3	1010	010	80.0
33.3	20	00010011	12	1	5	3	3	0111	010	75.0
33.3	20	00010011	12	1	7	2	2	1000	001	83.3
33.3	24	00010111	10	1	3	3	3	0101	010	70.0
33.3	24	00010111	10	1	5	2	2	0110	001	80.0
33.3	30	00011101	8	1	3	2	2	0100	001	75.0
33.3	30	00011101	8	1	5	1	1	0101	000	87.5

**Caution** The values in Table 21-23 do not guarantee the operation of the network system. Thoroughly check the effect on the network system, taking into consideration oscillation errors and delays of the CAN bus and CAN transceiver.

**Remark**  $n = 0, 1$

Table 21-24. Representative Examples of Baud Rate Settings (f<sub>CANMOD</sub> = 16 MHz) (1/2)

Set Baud Rate Value (Unit: kbps)	Division Ratio of CnBRP Register	CnBRP Register Set Value	Valid Bit Rate Setting (Unit: kbps)					CnBTR Register Setting Value		Sampling Point (Unit: %)
			Length of DBT	SYNC SEGMENT	PROP SEGMENT	PHASE SEGMENT1	PHASE SEGMENT2	TSEG13 to TSEG10	TSEG22 to TSEG20	
1000	1	00000000	16	1	1	7	7	0111	110	56.3
1000	1	00000000	16	1	3	6	6	1000	101	62.5
1000	1	00000000	16	1	5	5	5	1001	100	68.8
1000	1	00000000	16	1	7	4	4	1010	011	75.0
1000	1	00000000	16	1	9	3	3	1011	010	81.3
1000	1	00000000	16	1	11	2	2	1100	001	87.5
1000	1	00000000	16	1	13	1	1	1101	000	93.8
1000	2	00000001	8	1	3	2	2	0100	001	75.0
1000	2	00000001	8	1	5	1	1	0101	000	87.5
500	2	00000001	16	1	1	7	7	0111	110	56.3
500	2	00000001	16	1	3	6	6	1000	101	62.5
500	2	00000001	16	1	5	5	5	1001	100	68.8
500	2	00000001	16	1	7	4	4	1010	011	75.0
500	2	00000001	16	1	9	3	3	1011	010	81.3
500	2	00000001	16	1	11	2	2	1100	001	87.5
500	2	00000001	16	1	13	1	1	1101	000	93.8
500	4	00000011	8	1	3	2	2	0100	001	75.0
500	4	00000011	8	1	5	1	1	0101	000	87.5
250	4	00000011	16	1	3	6	6	1000	101	62.5
250	4	00000011	16	1	5	5	5	1001	100	68.8
250	4	00000011	16	1	7	4	4	1010	011	75.0
250	4	00000011	16	1	9	3	3	1011	010	81.3
250	4	00000011	16	1	11	2	2	1100	001	87.5
250	8	00000111	8	1	3	2	2	0100	001	75.0
250	8	00000111	8	1	5	1	1	0101	000	87.5
125	8	00000111	16	1	3	6	6	1000	101	62.5
125	8	00000111	16	1	7	4	4	1010	011	75.0
125	8	00000111	16	1	9	3	3	1011	010	81.3
125	8	00000111	16	1	11	2	2	1100	001	87.5
125	16	00001111	8	1	3	2	2	0100	001	75.0
125	16	00001111	8	1	5	1	1	0101	000	87.5

**Caution** The values in Table 21-24 do not guarantee the operation of the network system. Thoroughly check the effect on the network system, taking into consideration oscillation errors and delays of the CAN bus and CAN transceiver.

**Remark** n = 0, 1



Table 21-24. Representative Examples of Baud Rate Settings ( $f_{CANMOD} = 16 \text{ MHz}$ ) (2/2)

Set Baud Rate Value (Unit: kbps)	Division Ratio of CnBRP Register	CnBRP Register Set Value	Valid Bit Rate Setting (Unit: kbps)					CnBTR Register Setting Value		Sampling Point (Unit: %)
			Length of DBT	SYNC SEGMENT	PROP SEGMENT	PHASE SEGMENT1	PHASE SEGMENT2	TSEG13 to TSEG10	TSEG22 to TSEG20	
100	8	00000111	20	1	9	5	5	1101	100	75.0
100	8	00000111	20	1	11	4	4	1110	011	80.0
100	10	00001001	16	1	7	4	4	1010	011	75.0
100	10	00001001	16	1	9	3	3	1011	010	81.3
100	16	00001111	10	1	3	3	3	0101	010	70.0
100	16	00001111	10	1	5	2	2	0110	001	80.0
100	20	00010011	8	1	3	2	2	0100	001	75.0
83.3	8	00000111	24	1	7	8	8	1110	111	66.7
83.3	8	00000111	24	1	9	7	7	1111	110	70.8
83.3	12	00001011	16	1	7	4	4	1010	011	75.0
83.3	12	00001011	16	1	9	3	3	1011	010	81.3
83.3	12	00001011	16	1	11	2	2	1100	001	87.5
83.3	16	00001111	12	1	5	3	3	0111	010	75.0
83.3	16	00001111	12	1	7	2	2	1000	001	83.3
83.3	24	00010111	8	1	3	2	2	0100	001	75.0
83.3	24	00010111	8	1	5	1	1	0101	000	87.5
33.3	30	00011101	24	1	7	8	8	1110	111	66.7
33.3	30	00011101	24	1	9	7	7	1111	110	70.8
33.3	24	00010111	20	1	9	5	5	1101	100	75.0
33.3	24	00010111	20	1	11	4	4	1110	011	80.0
33.3	30	00011101	16	1	7	4	4	1010	011	75.0
33.3	30	00011101	16	1	9	3	3	1011	010	81.3
33.3	32	00011111	15	1	8	3	3	1010	010	80.0
33.3	32	00011111	15	1	10	2	2	1011	001	86.7
33.3	37	00100100	13	1	6	3	3	1000	010	76.9
33.3	37	00100100	13	1	8	2	2	1001	001	84.6
33.3	40	00100111	12	1	5	3	3	0111	010	75.0
33.3	40	00100111	12	1	7	2	2	1000	001	83.3
33.3	48	00101111	10	1	3	3	3	0101	010	70.0
33.3	48	00101111	10	1	5	2	2	0110	001	80.0
33.3	60	00111011	8	1	3	2	2	0100	001	75.0
33.3	60	00111011	8	1	5	1	1	0101	000	87.5

**Caution** The values in Table 21-24 do not guarantee the operation of the network system. Thoroughly check the effect on the network system, taking into consideration oscillation errors and delays of the CAN bus and CAN transceiver.

**Remark** n = 0, 1

## 21.16 Operation of CAN Controller

The processing procedure shown below is recommended to operate the CAN controller. Develop your program by referring to this recommended processing procedure.

**Remark** n = 0, 1  
m = 00 to 31

**Figure 21-36. Initialization**

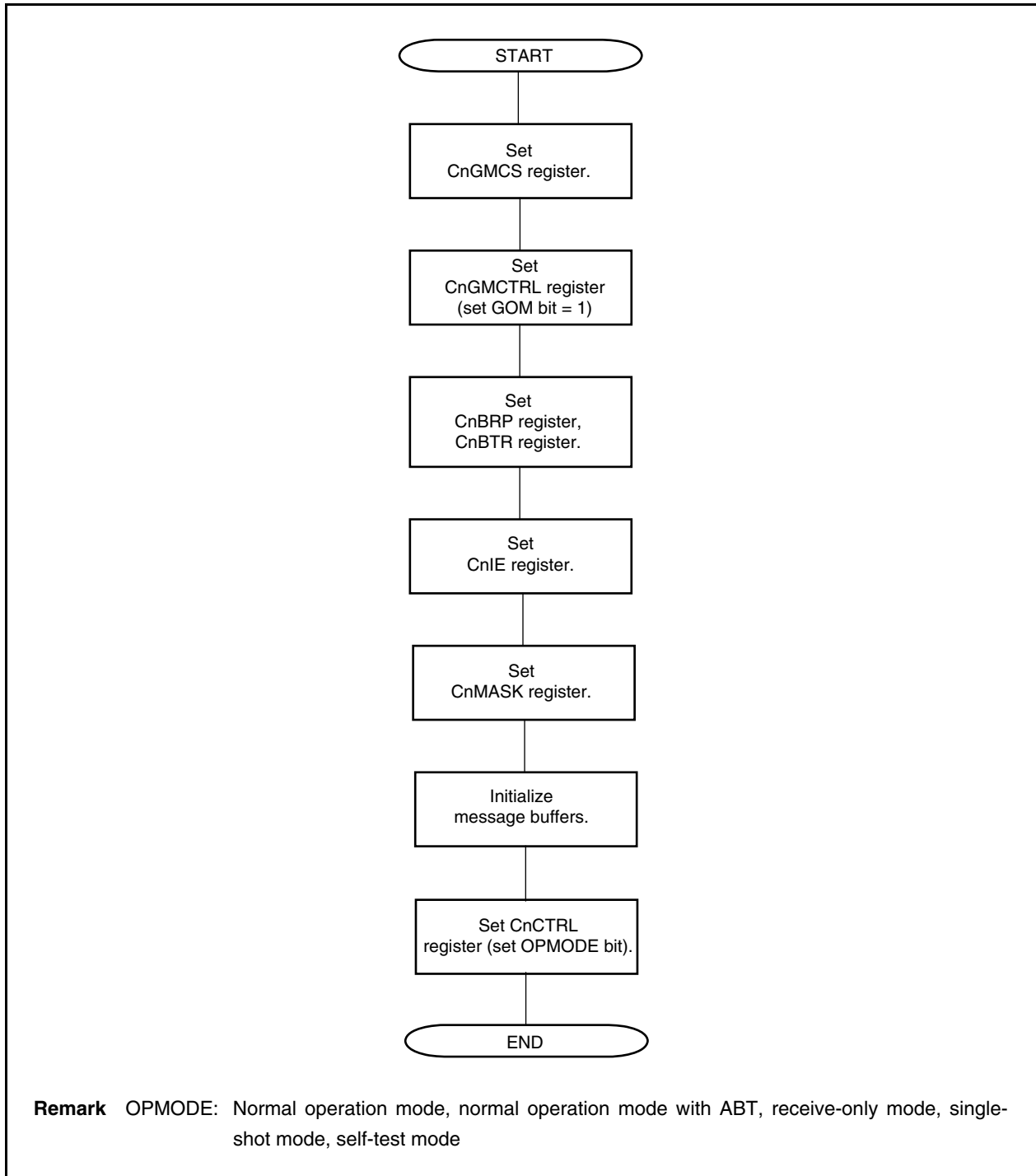

Figure 21-37. Re-initialization

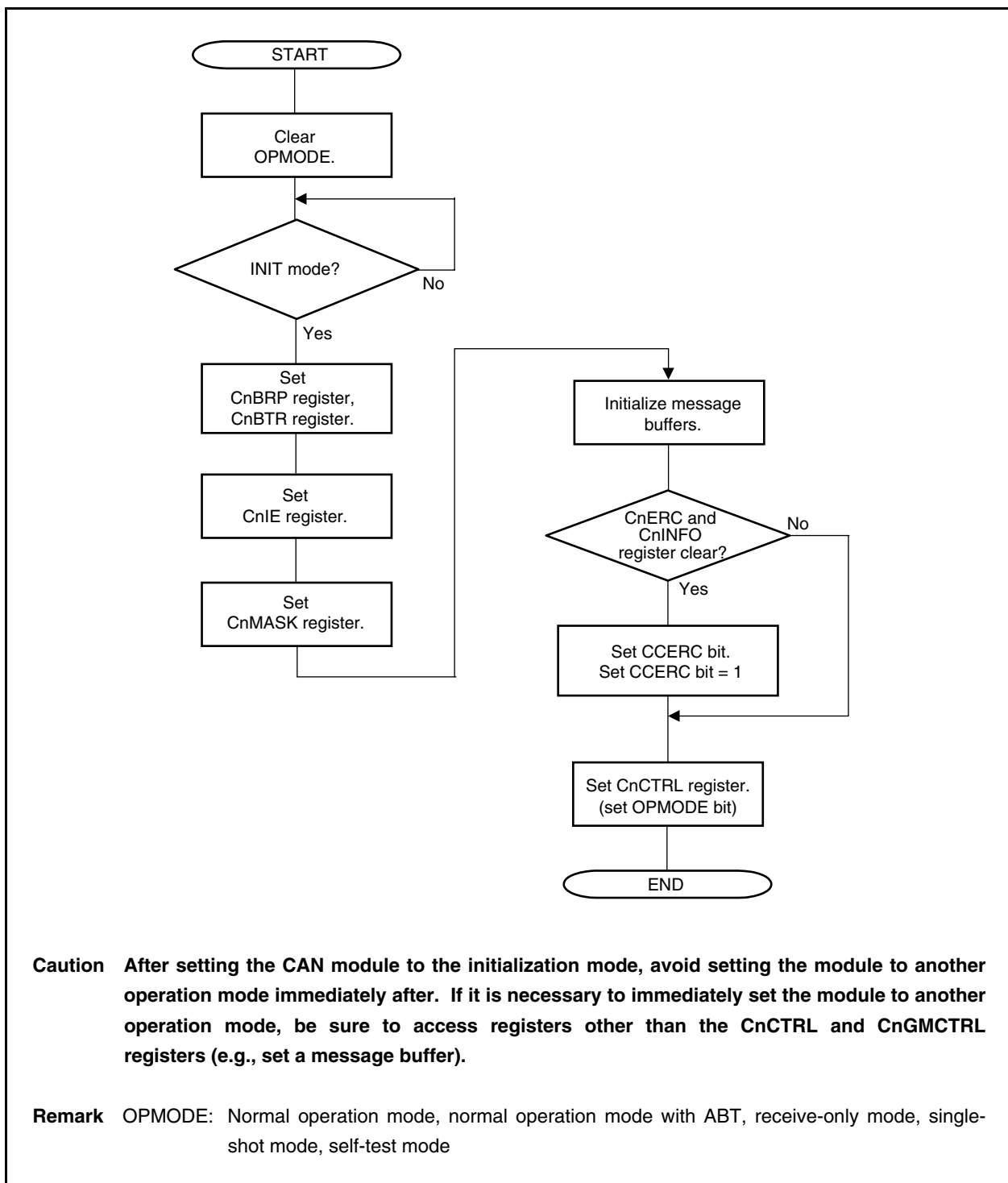
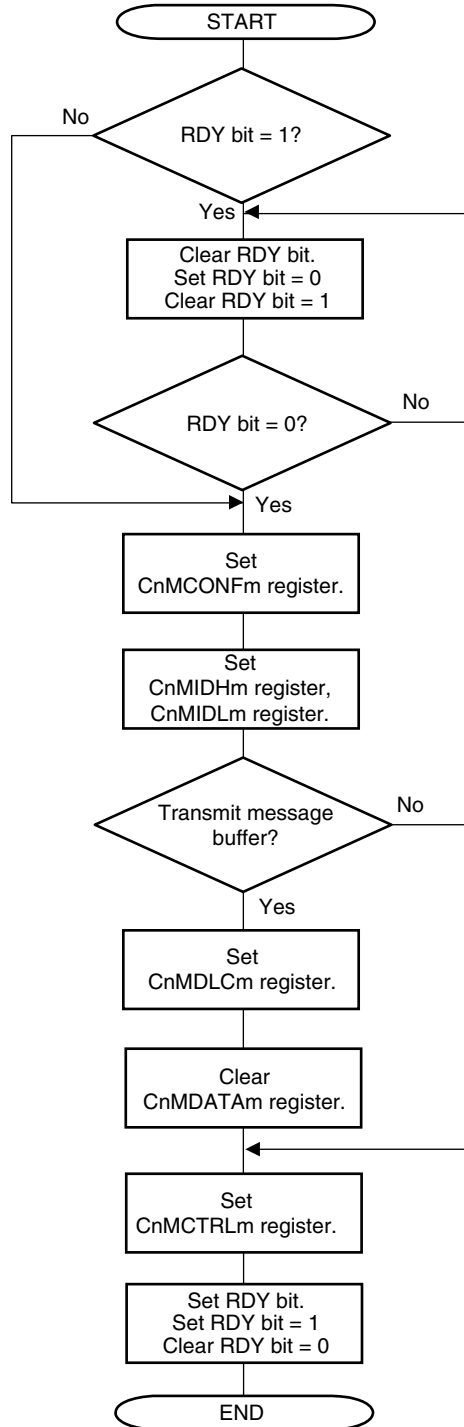

Figure 21-38. Message Buffer Initialization



- Cautions**
1. Before a message buffer is initialized, the RDY bit must be cleared.
  2. Make the following settings for message buffers not used by the application.
    - Clear the CnMCTRLm.RDY, CnMCTRLm.TRQ, and CnMCTRLm.DN bits to 0.
    - Clear the CnMCONFm.MA0 bit to 0.

Figure 21-39 shows the processing for a receive message buffer (CnMCONFm.MT2 to CnMCONFm.MT0 bits = 001B to 101B).

**Figure 21-39. Message Buffer Redefinition**

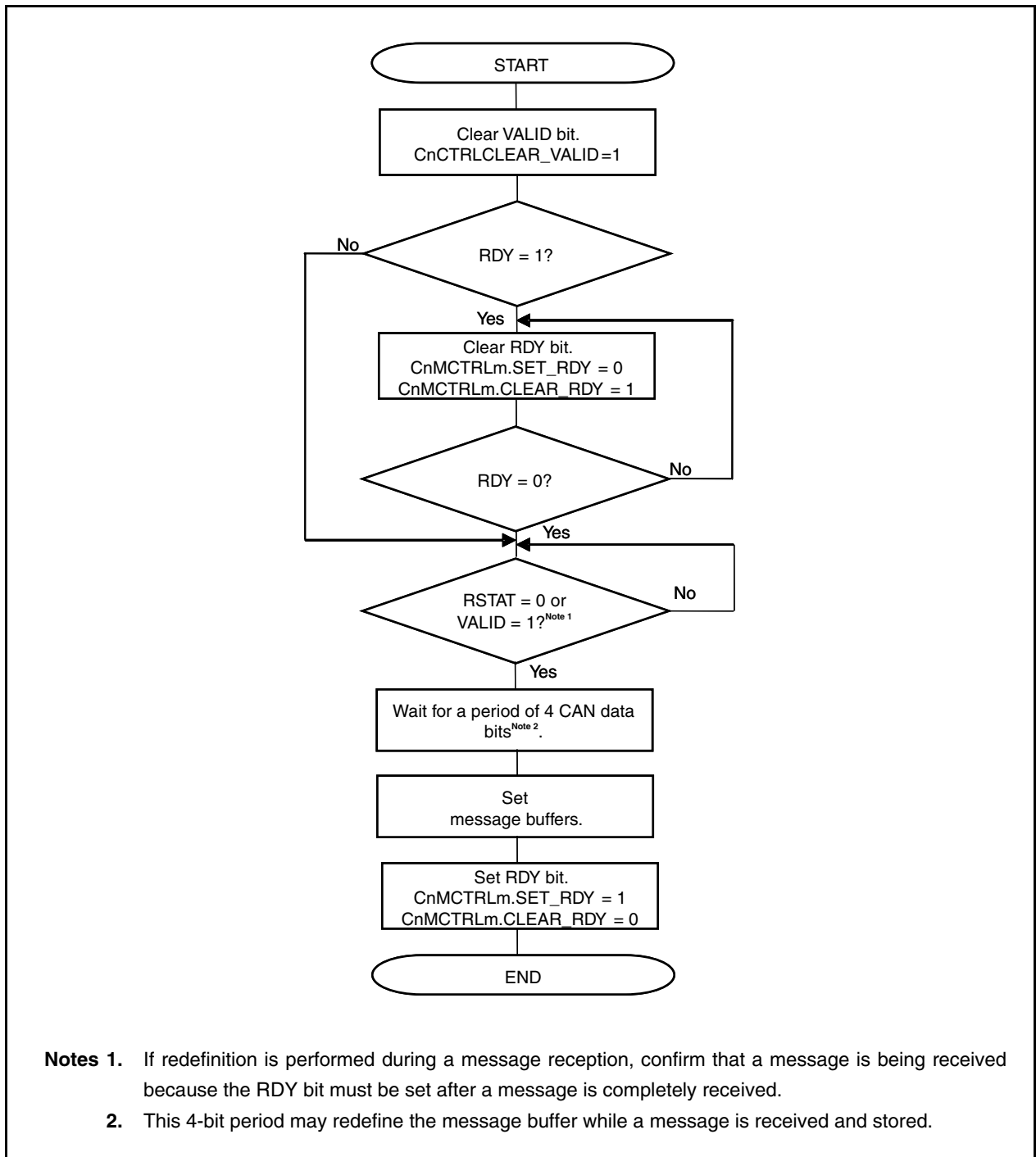

Figure 21-40 shows the processing for a transmit message buffer during transmission (MT2 to MT0 bits of CnMCONFm register = 000B).

Figure 21-40. Message Buffer Redefinition during Transmission

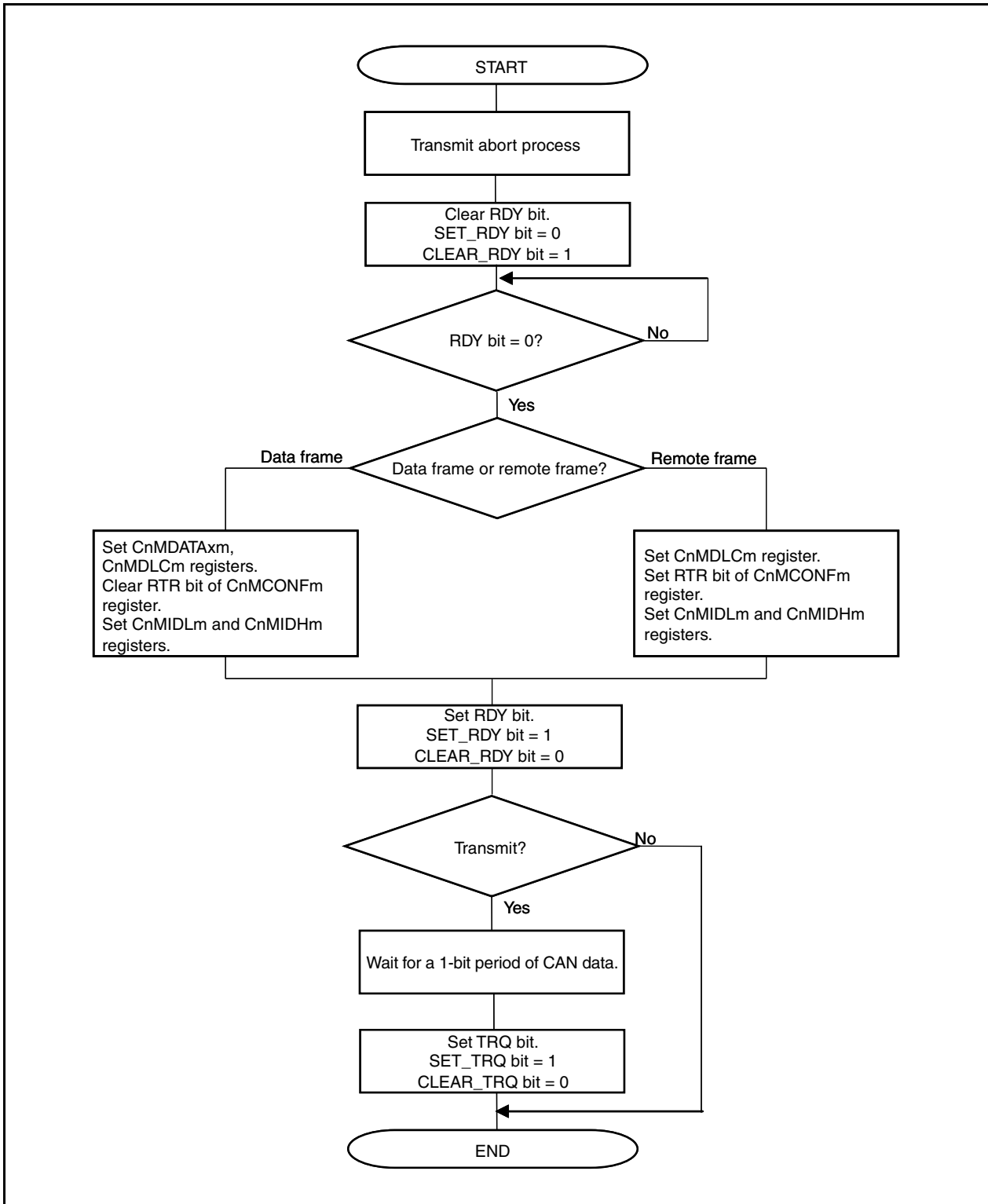

Figure 21-41 shows the processing for a transmit message buffer (CnMCONFm.MT2 to CnMCONFm.MT0 bits = 000B).

Figure 21-41. Message Transmit Processing

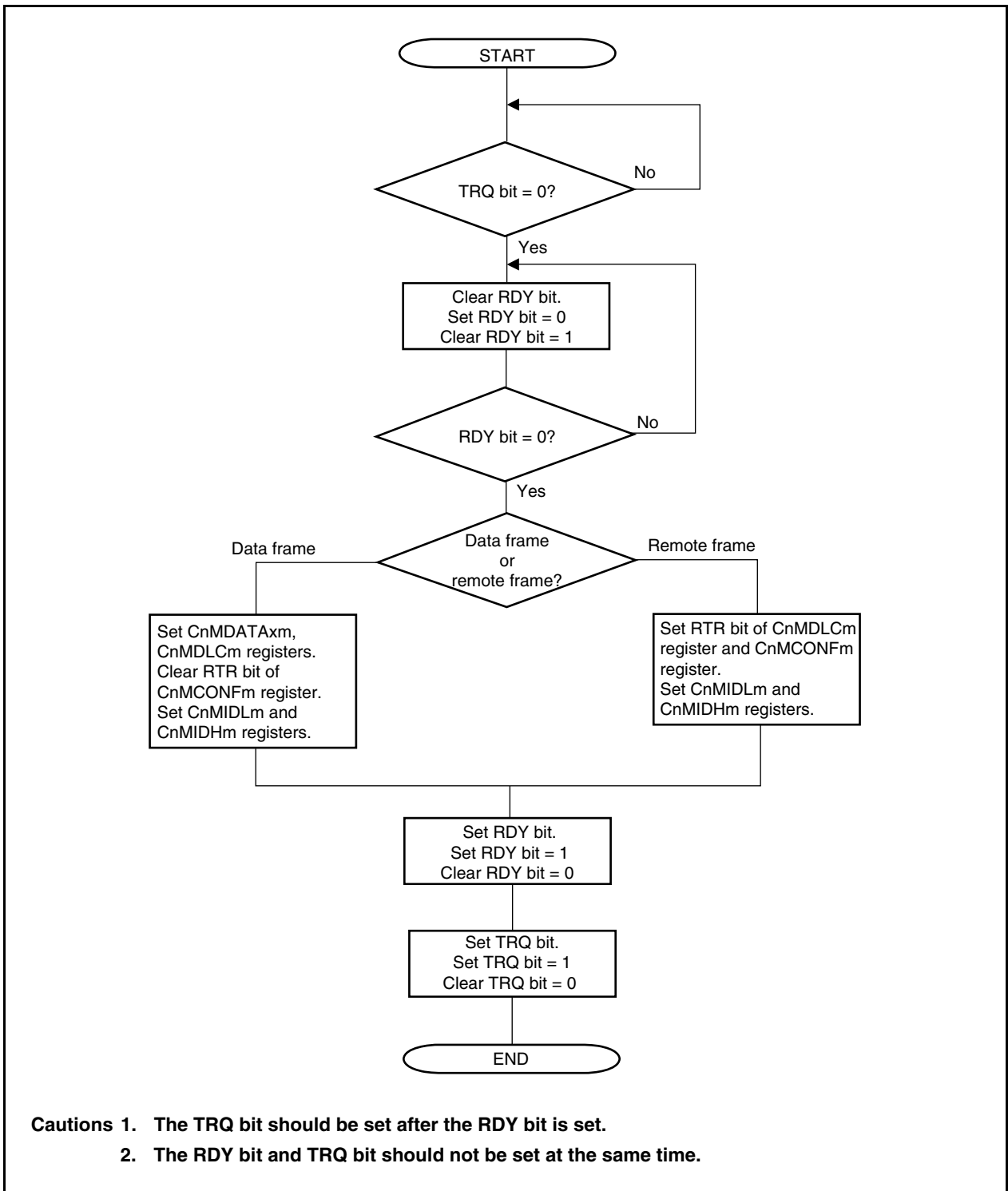
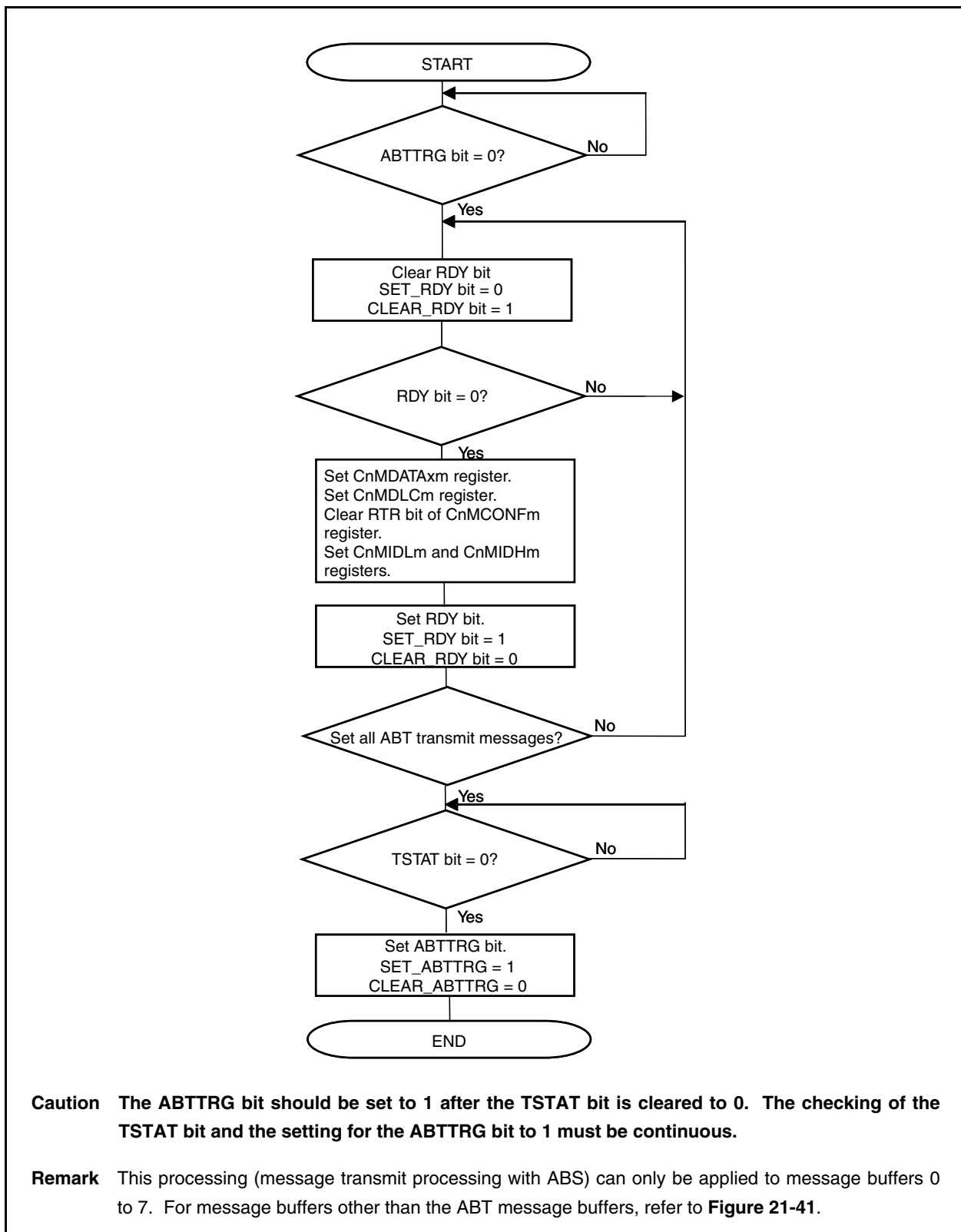

Figure 21-42 shows the processing for a transmit message buffer (CnMCONFm.MT2 to CnMCONFm.MT0 bits = 000B).

Figure 21-42. ABT Message Transmit Processing



**Caution** The ABTTRG bit should be set to 1 after the TSTAT bit is cleared to 0. The checking of the TSTAT bit and the setting for the ABTTRG bit to 1 must be continuous.

**Remark** This processing (message transmit processing with ABS) can only be applied to message buffers 0 to 7. For message buffers other than the ABT message buffers, refer to **Figure 21-41**.



Figure 21-43. Transmission via Interrupt (Using CnLOPT Register)

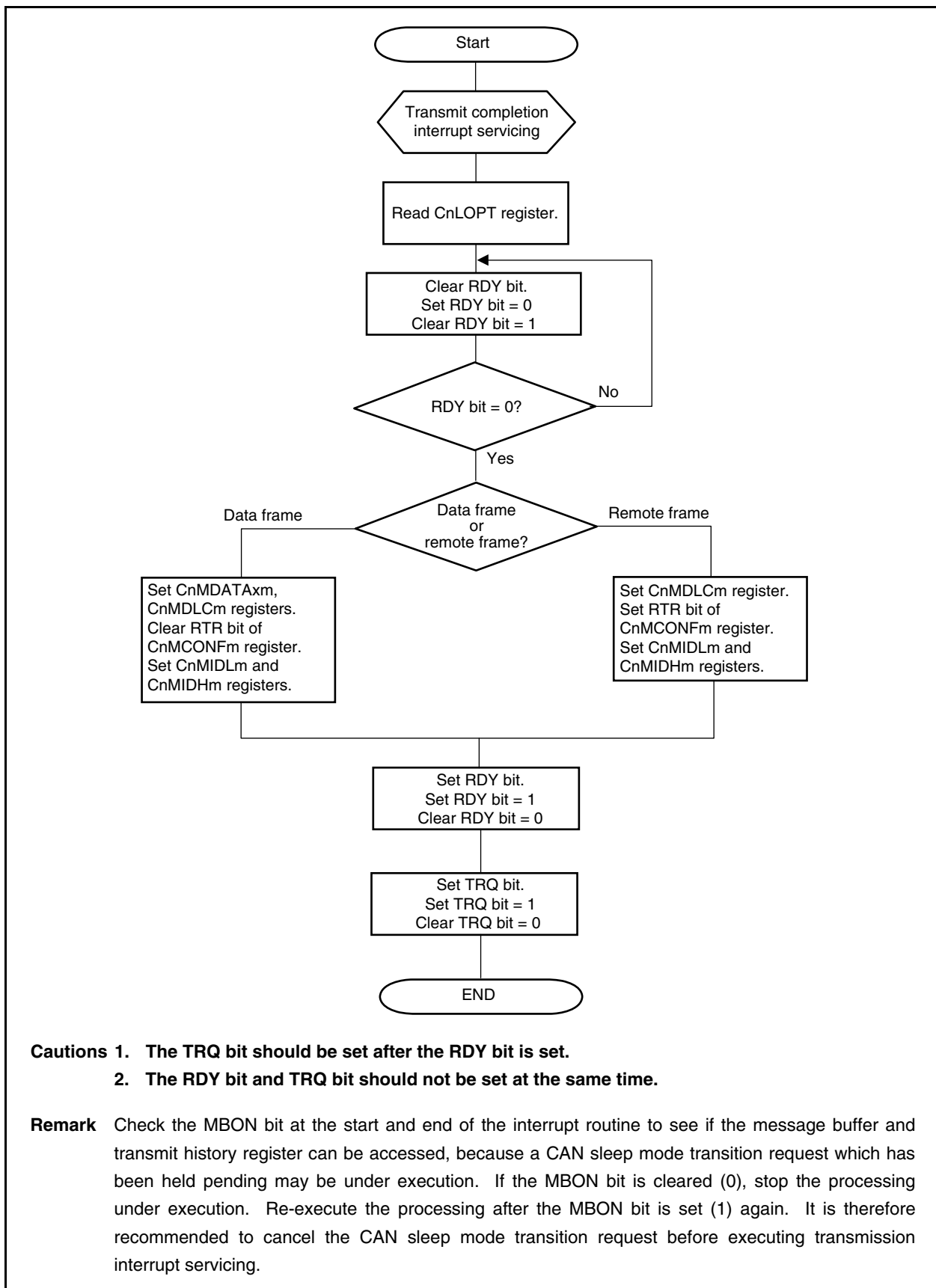

- Cautions**
1. The TRQ bit should be set after the RDY bit is set.
  2. The RDY bit and TRQ bit should not be set at the same time.

**Remark** Check the MBON bit at the start and end of the interrupt routine to see if the message buffer and transmit history register can be accessed, because a CAN sleep mode transition request which has been held pending may be under execution. If the MBON bit is cleared (0), stop the processing under execution. Re-execute the processing after the MBON bit is set (1) again. It is therefore recommended to cancel the CAN sleep mode transition request before executing transmission interrupt servicing.

Figure 21-44. Transmission via Interrupt (Using CnTGPT Register)

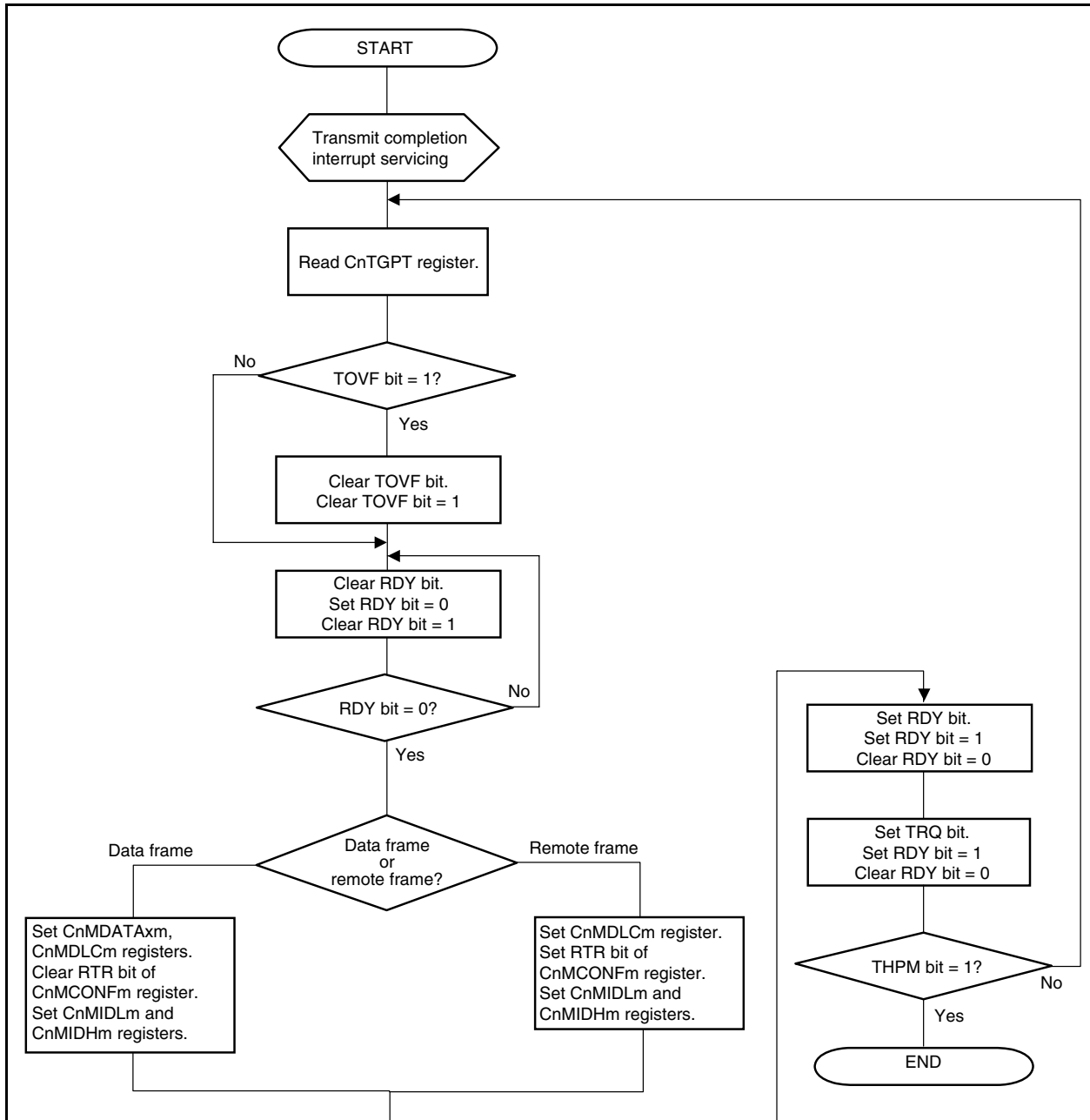

- Cautions**
1. The TRQ bit should be set after the RDY bit is set.
  2. The RDY bit and TRQ bit should not be set at the same time.

- Remarks**
1. Check the MBON bit at the start and end of the interrupt routine to see if the message buffer and transmit history register can be accessed, because a CAN sleep mode transition request which has been held pending may be under execution. If the MBON bit is cleared (0), stop the processing under execution. Re-execute the processing after the MBON bit is set (1) again. It is therefore recommended to cancel the CAN sleep mode transition request before executing transmission interrupt servicing.
  2. If the TOVF bit is set (1) again, the transmit history list contradicts. Therefore, scan all the transmit message buffers that have completed transmission.

Figure 21-45. Transmission via Software Polling

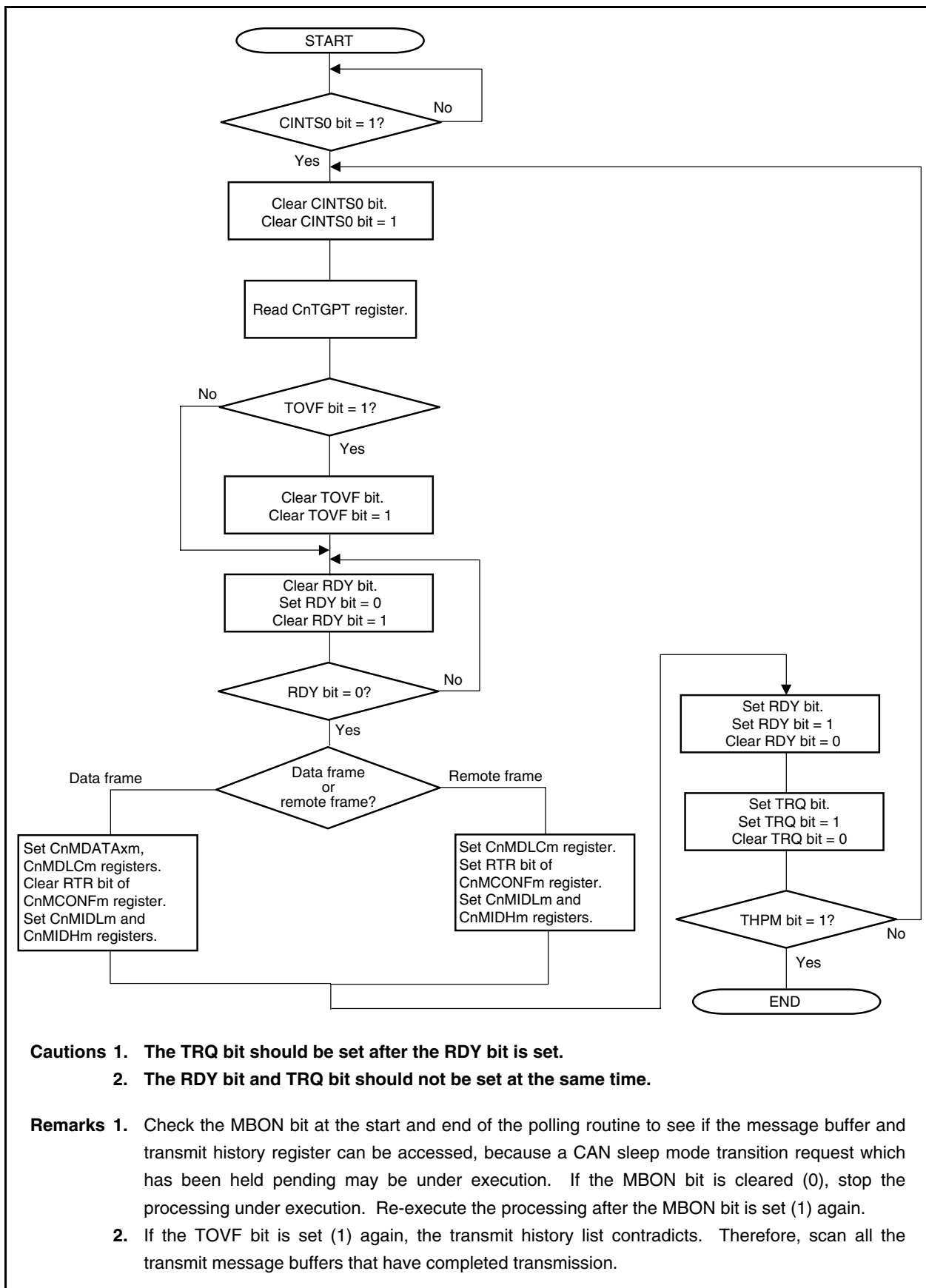

- Cautions**
1. The TRQ bit should be set after the RDY bit is set.
  2. The RDY bit and TRQ bit should not be set at the same time.

- Remarks**
1. Check the MBON bit at the start and end of the polling routine to see if the message buffer and transmit history register can be accessed, because a CAN sleep mode transition request which has been held pending may be under execution. If the MBON bit is cleared (0), stop the processing under execution. Re-execute the processing after the MBON bit is set (1) again.
  2. If the TOVF bit is set (1) again, the transmit history list contradicts. Therefore, scan all the transmit message buffers that have completed transmission.

Figure 21-46. Transmission Abort Processing (Other Than in Normal Operation Mode with ABT)

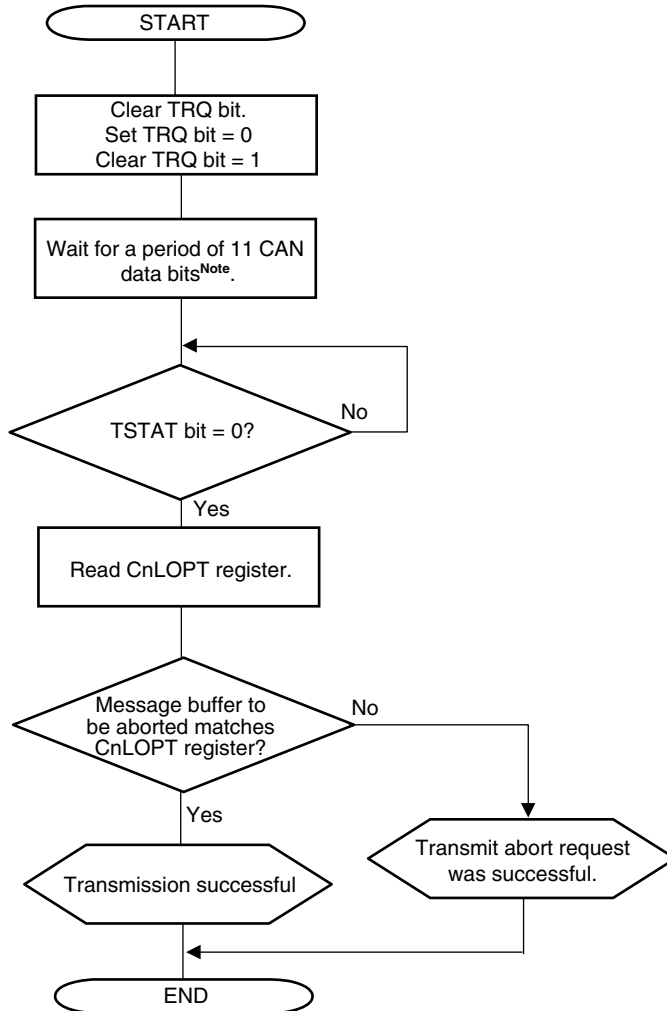

**Note** During a period of a total of 11 bits, 3 bits of interframe space and 8 bits of suspend transmission, the transmission request may have already been acknowledged by the protocol layer. Consequently, transmission may not be aborted but started even if the TRQ bit is cleared.

- Cautions**
1. Execute transmission abort processing by clearing the TRQ bit, not the RDY bit.
  2. Before making a sleep mode transition request, confirm that there is no transmission request left using this processing.
  3. The TSTAT bit can be periodically checked by a user application or can be checked after the transmit completion interrupt.
  4. Do not execute a new transmission request that includes other message buffers while transmission abort processing is in progress.
  5. If data of the same message buffer are successively transmitted or if only one message buffer is used, judgments whether transmission has been successfully executed or failed may contradict. In such a case, make a judgment by using the history information of the CnTGPT register.

Figure 21-47. Transmission Abort Processing Except for ABT Transmission  
(Normal Operation Mode with ABT)

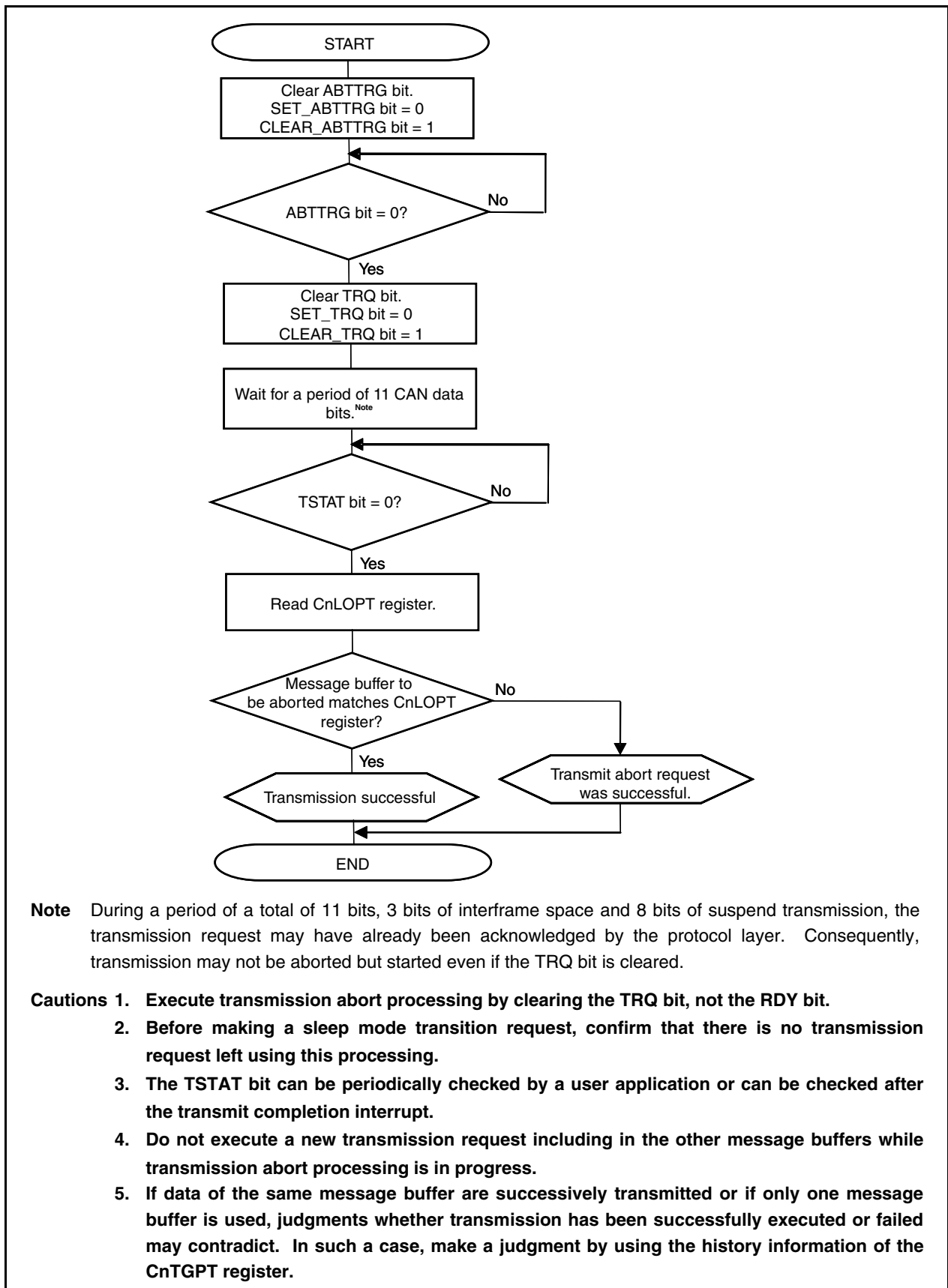

**Note** During a period of a total of 11 bits, 3 bits of interframe space and 8 bits of suspend transmission, the transmission request may have already been acknowledged by the protocol layer. Consequently, transmission may not be aborted but started even if the TRQ bit is cleared.

- Cautions**
1. Execute transmission abort processing by clearing the TRQ bit, not the RDY bit.
  2. Before making a sleep mode transition request, confirm that there is no transmission request left using this processing.
  3. The TSTAT bit can be periodically checked by a user application or can be checked after the transmit completion interrupt.
  4. Do not execute a new transmission request including in the other message buffers while transmission abort processing is in progress.
  5. If data of the same message buffer are successively transmitted or if only one message buffer is used, judgments whether transmission has been successfully executed or failed may contradict. In such a case, make a judgment by using the history information of the CnTGPT register.

Figure 21-48 (a) shows processing that does not skip resuming the transmission of a message that was interrupted when the transmission of an ABT message buffer was aborted.

**Figure 21-48 (a). ABT Transmission Abort Processing (Normal Operation Mode with ABT)**

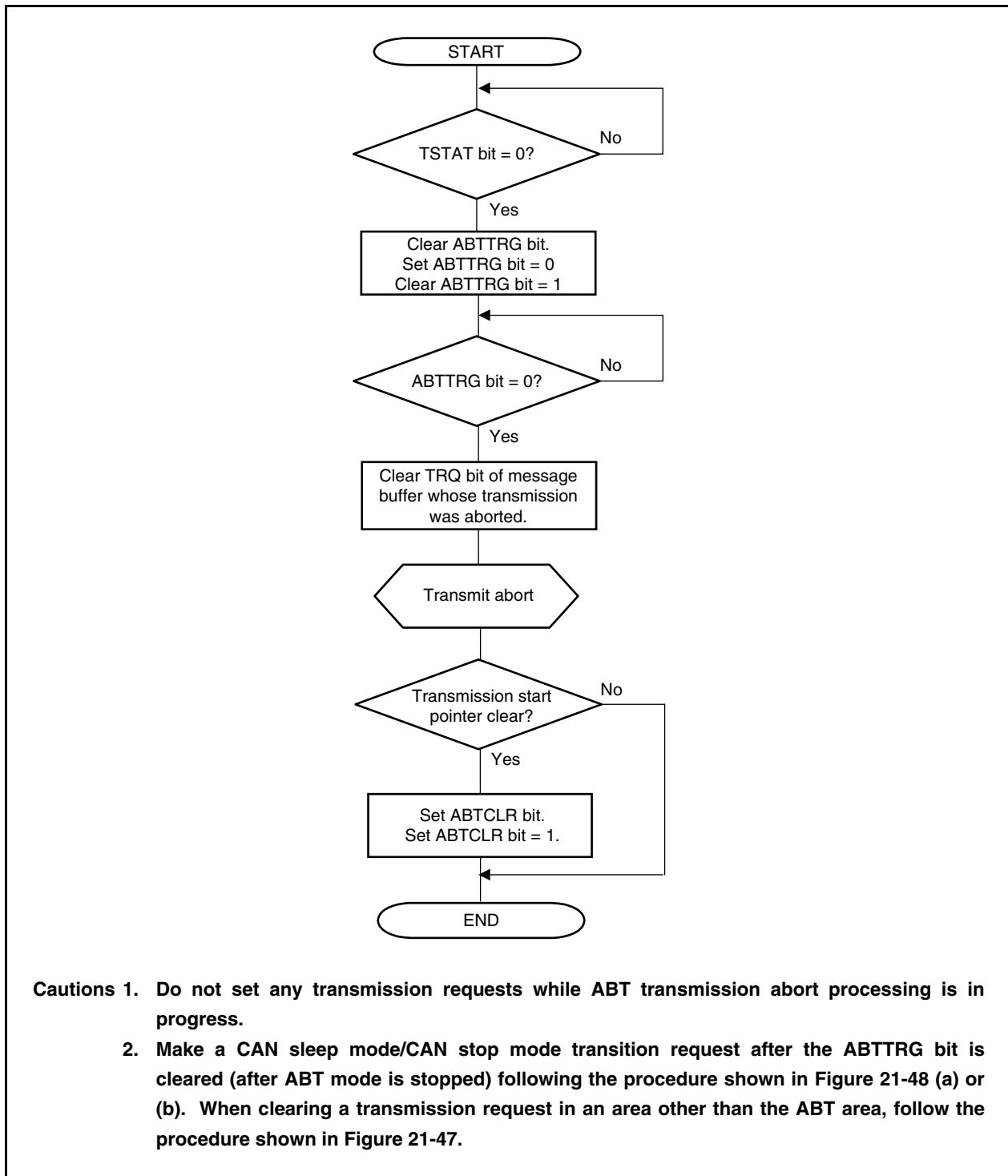

Figure 21-48 (b) shows the processing that does not skip resuming the transmission of a message that was interrupted when the transmission of an ABT message buffer was aborted.

**Figure 21-48 (b). ABT Transmission Abort Processing (Normal Operation Mode with ABT)**

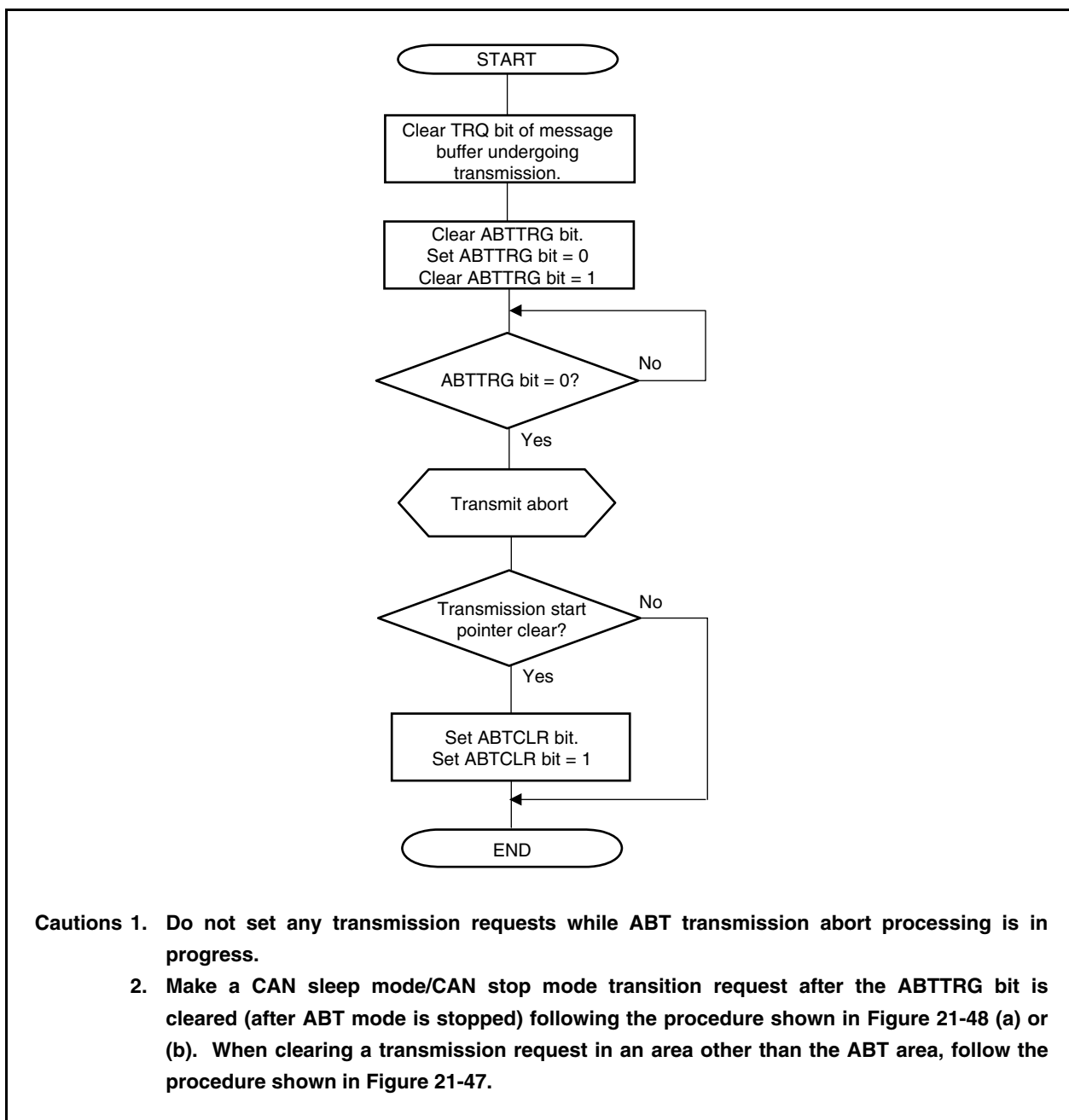

Figure 21-49. Reception via Interrupt (Using CnLIPT Register)

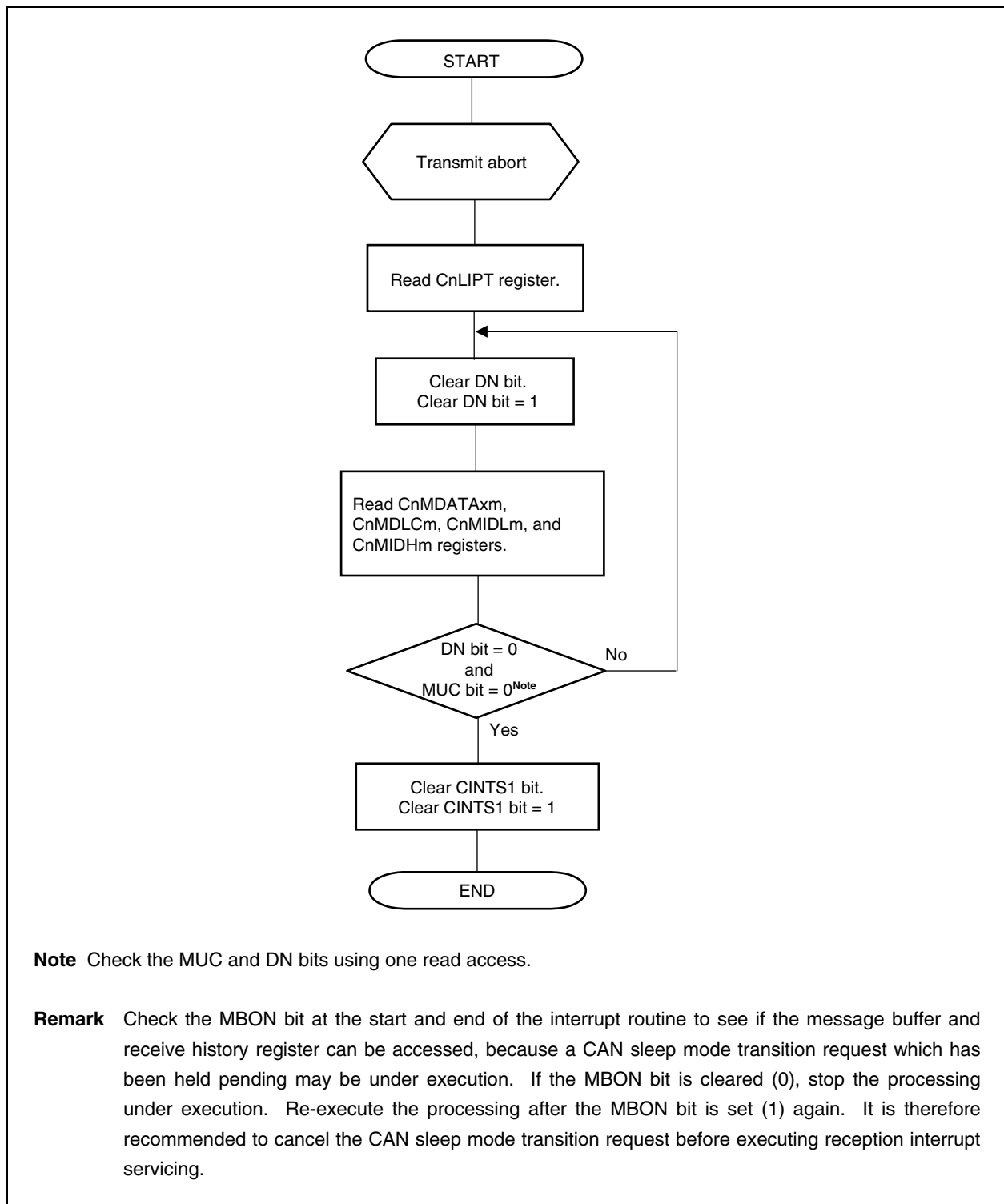
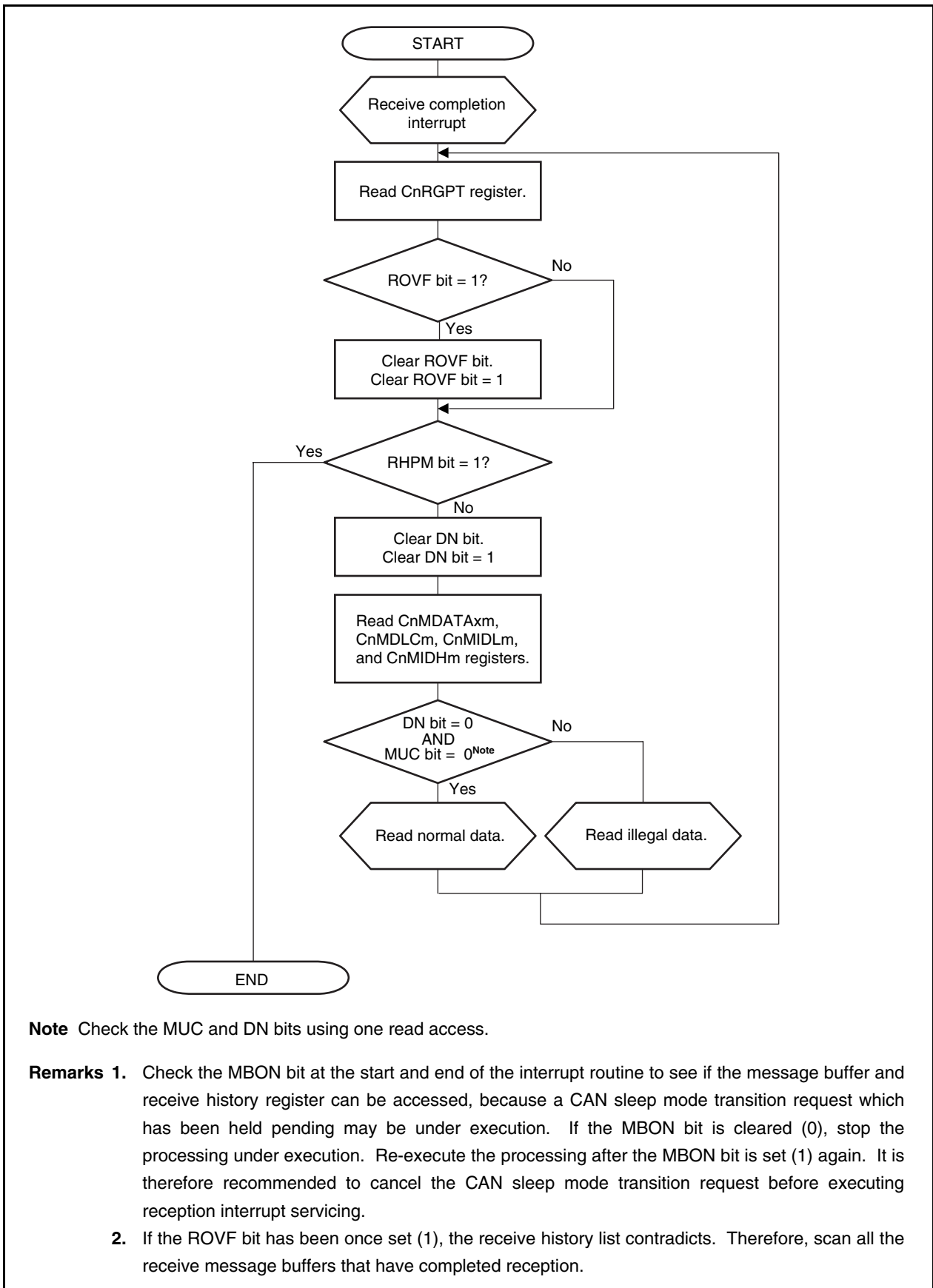



Figure 21-50. Reception via Interrupt (Using CnRGPT Register)



**Note** Check the MUC and DN bits using one read access.

**Remarks 1.** Check the MBON bit at the start and end of the interrupt routine to see if the message buffer and receive history register can be accessed, because a CAN sleep mode transition request which has been held pending may be under execution. If the MBON bit is cleared (0), stop the processing under execution. Re-execute the processing after the MBON bit is set (1) again. It is therefore recommended to cancel the CAN sleep mode transition request before executing reception interrupt servicing.

**2.** If the ROVF bit has been once set (1), the receive history list contradicts. Therefore, scan all the receive message buffers that have completed reception.

Figure 21-51. Reception via Software Polling

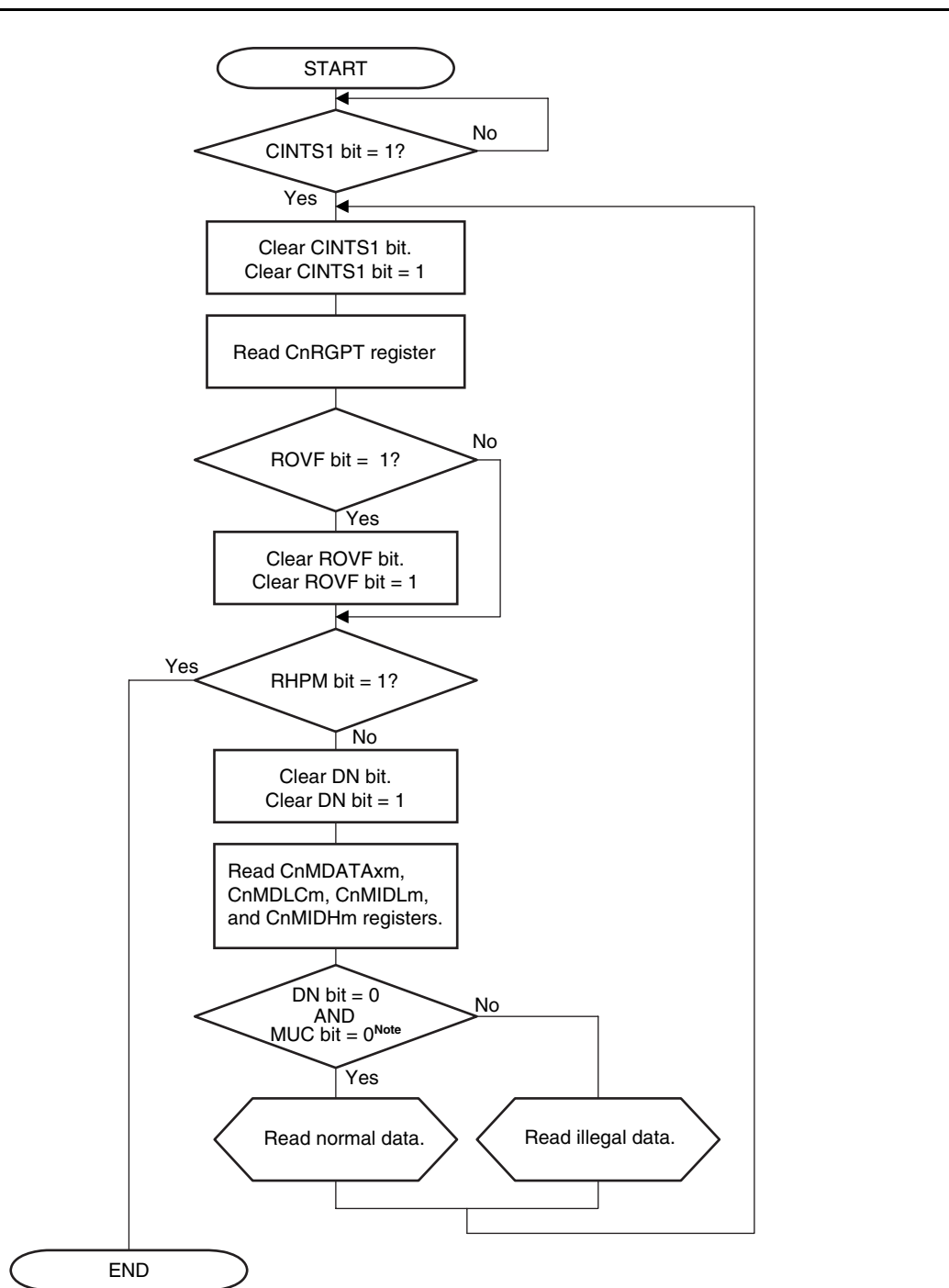

**Note** Check the MUC and DN bits using one read access.

- Remarks 1.** Check the MBON bit at the start and end of the polling routine to see if the message buffer and receive history register can be accessed, because a CAN sleep mode transition request which has been held pending may be under execution. If the MBON bit is cleared (0), stop the processing under execution. Re-execute the processing after the MBON bit is set (1) again.
- 2.** If the ROVF bit has been once set (1), the receive history list contradicts. Therefore, scan all the receive message buffers that have completed reception.

Figure 21-52. Setting CAN Sleep Mode/Stop Mode

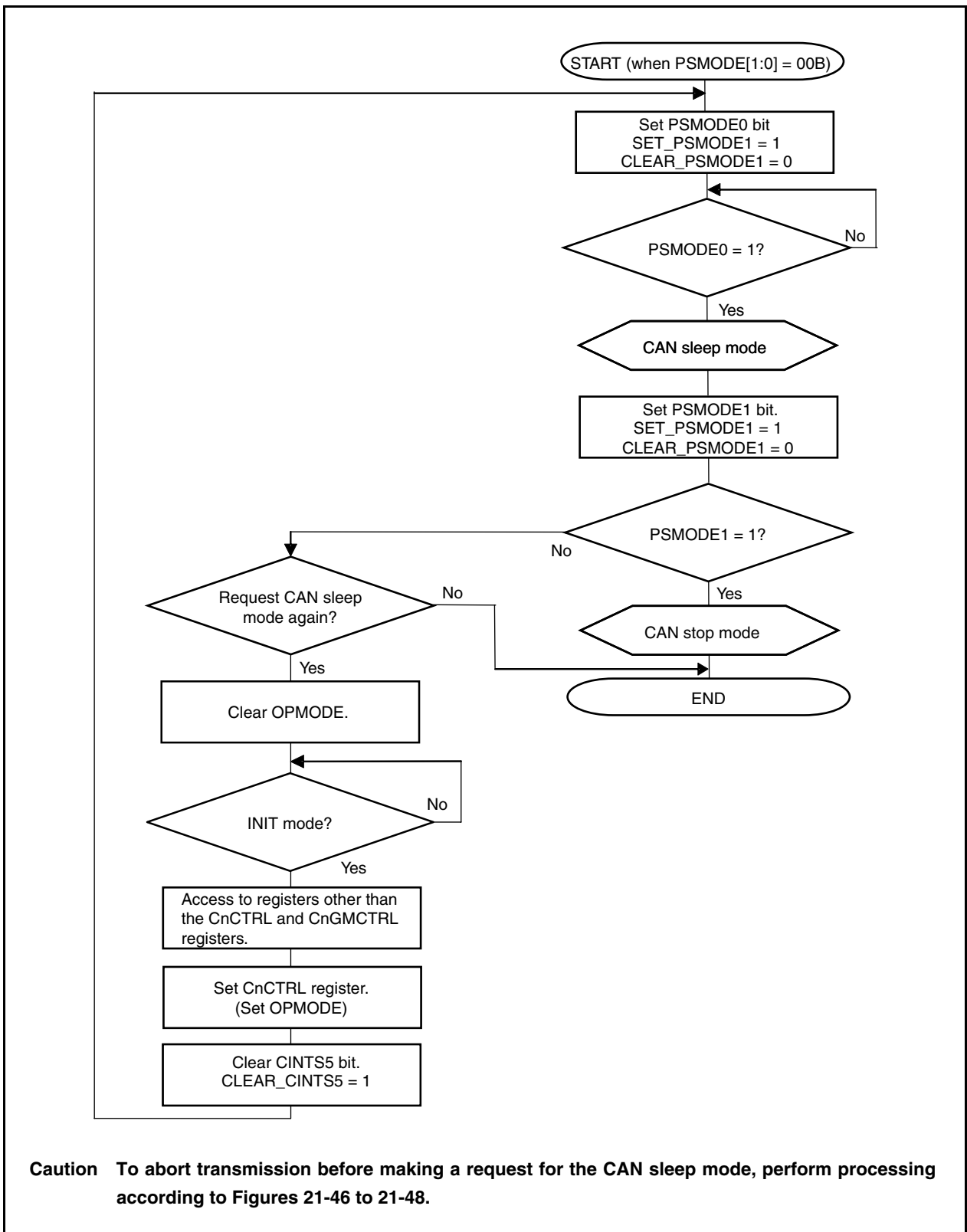

Figure 21-53. Clear CAN Sleep/Stop Mode

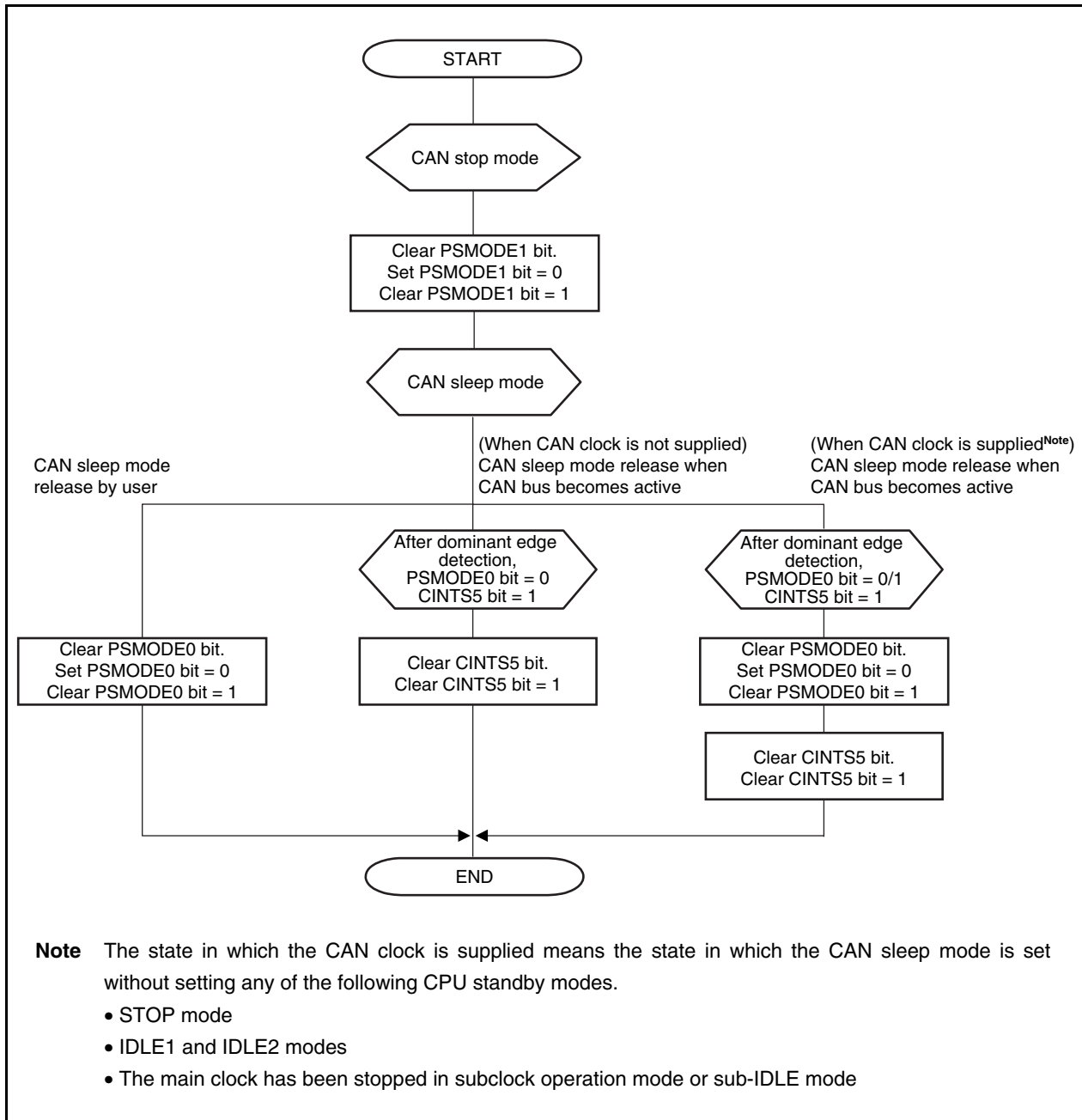

Figure 21-54. Bus-off Recovery (Other Than in Normal Operation Mode with ABT)

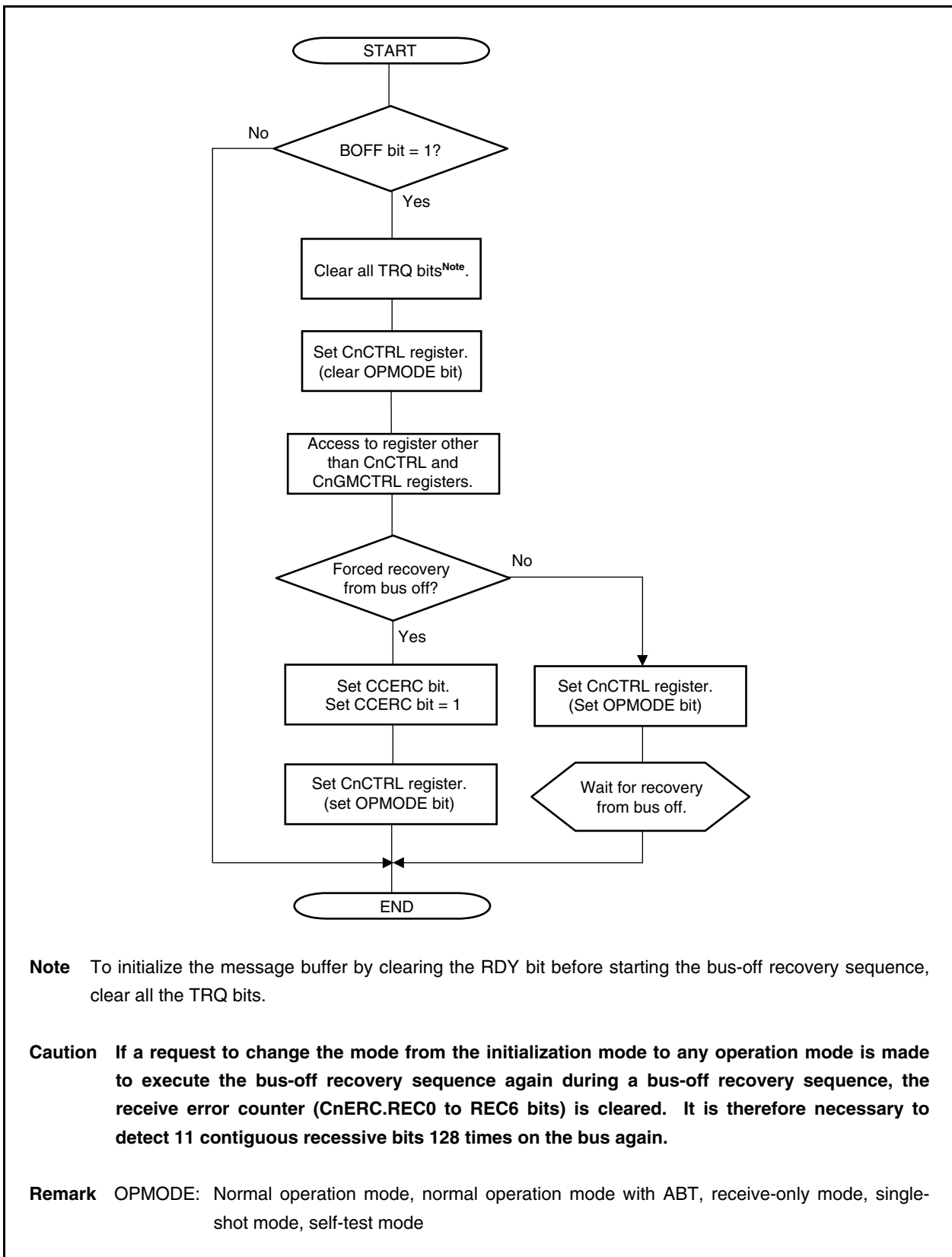

Figure 21-55. Bus-off Recovery (Normal Operation Mode with ABT)

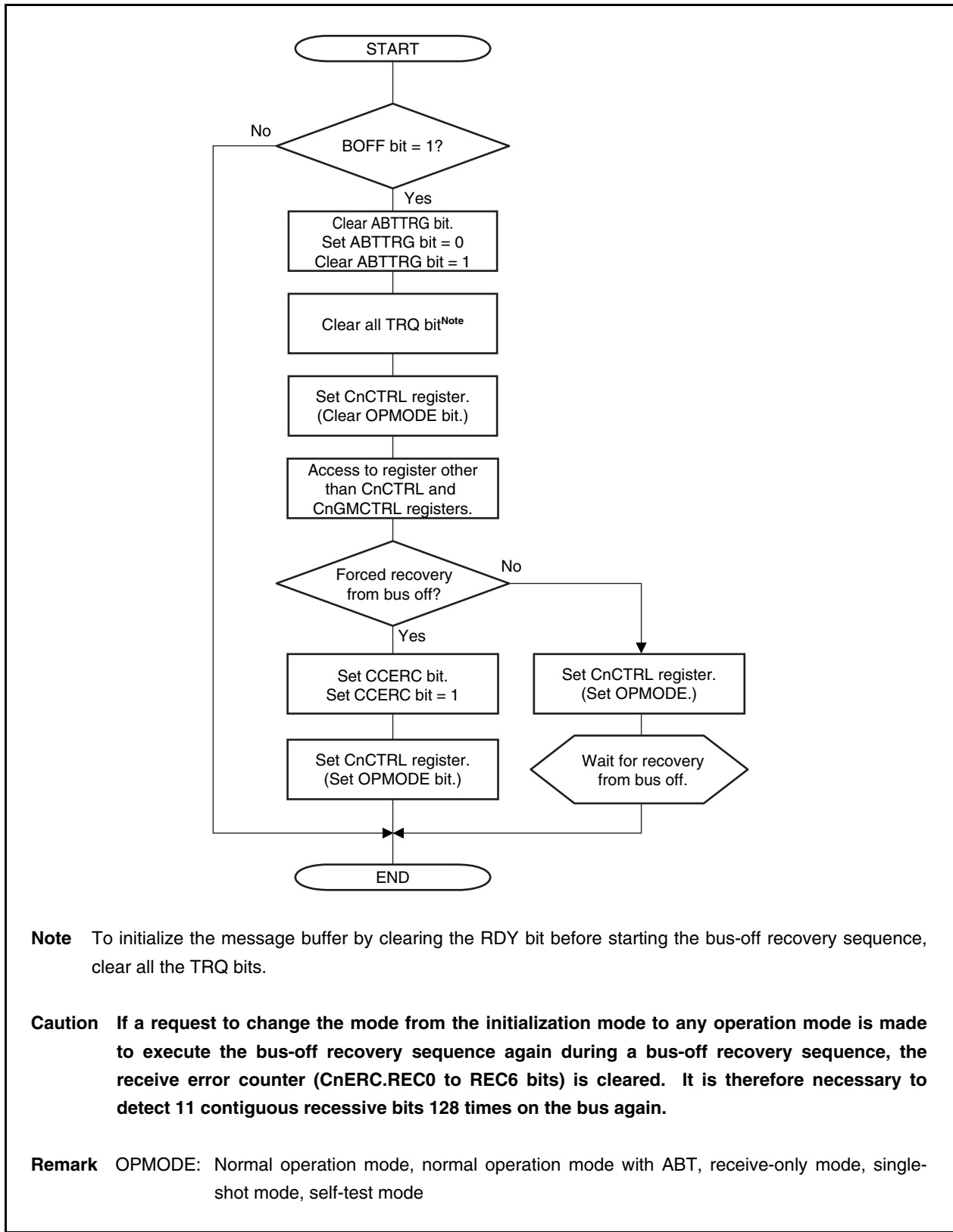

Figure 21-56. Normal Shutdown Process

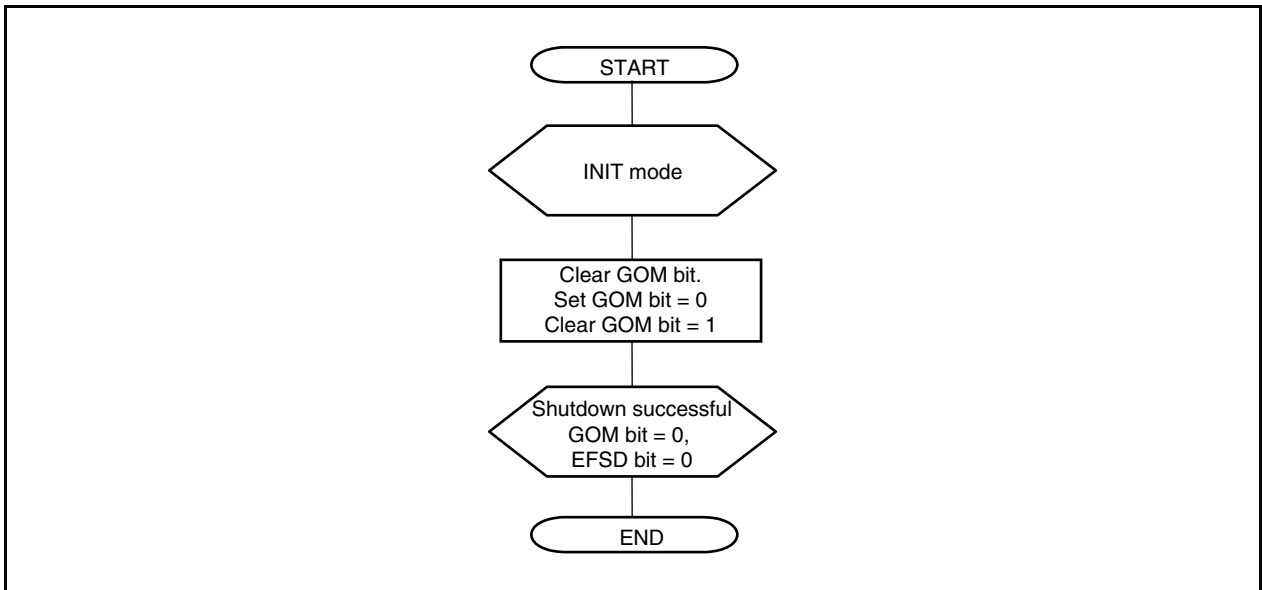

Figure 21-57. Forced Shutdown Process

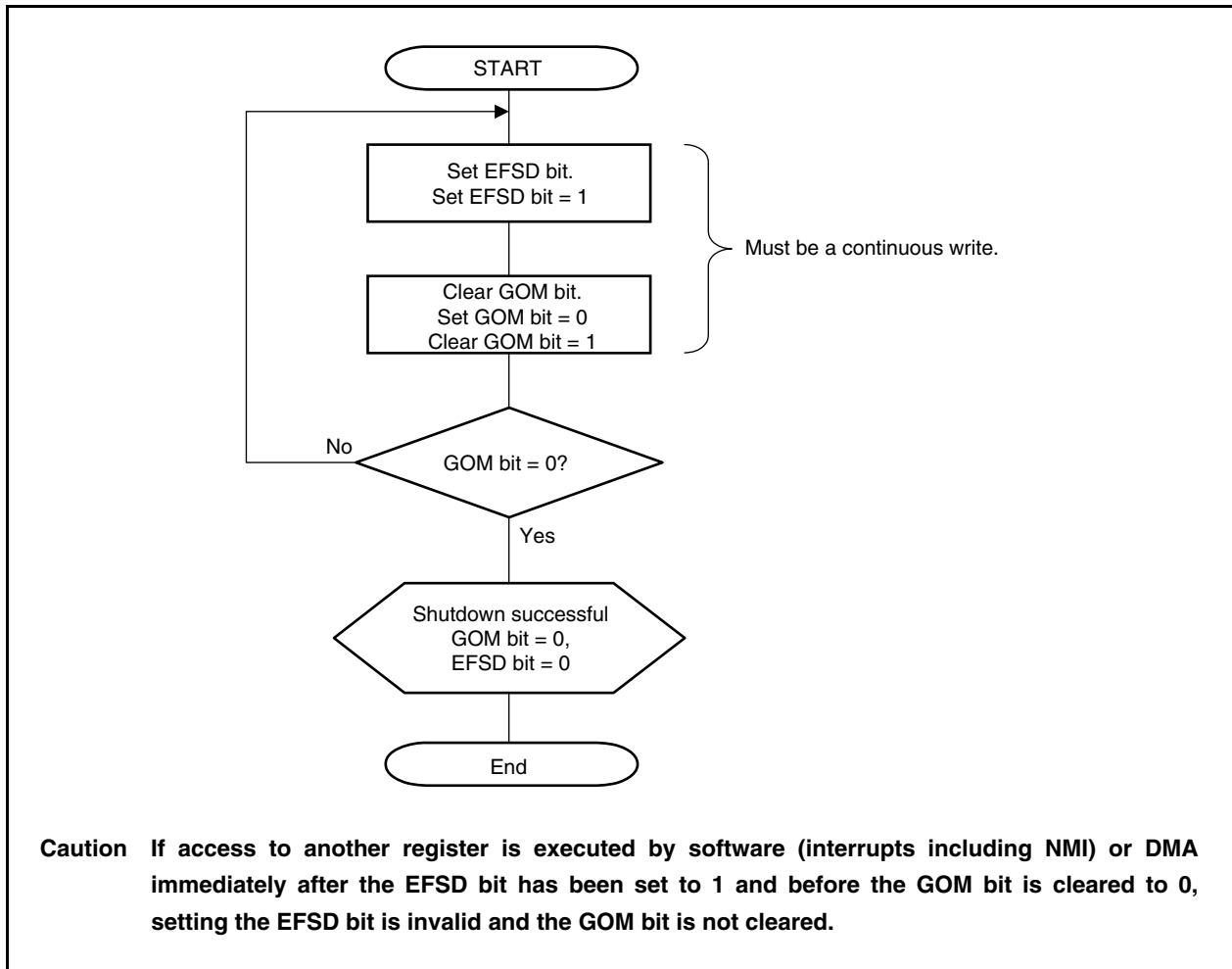



Figure 21-58. Error Handling

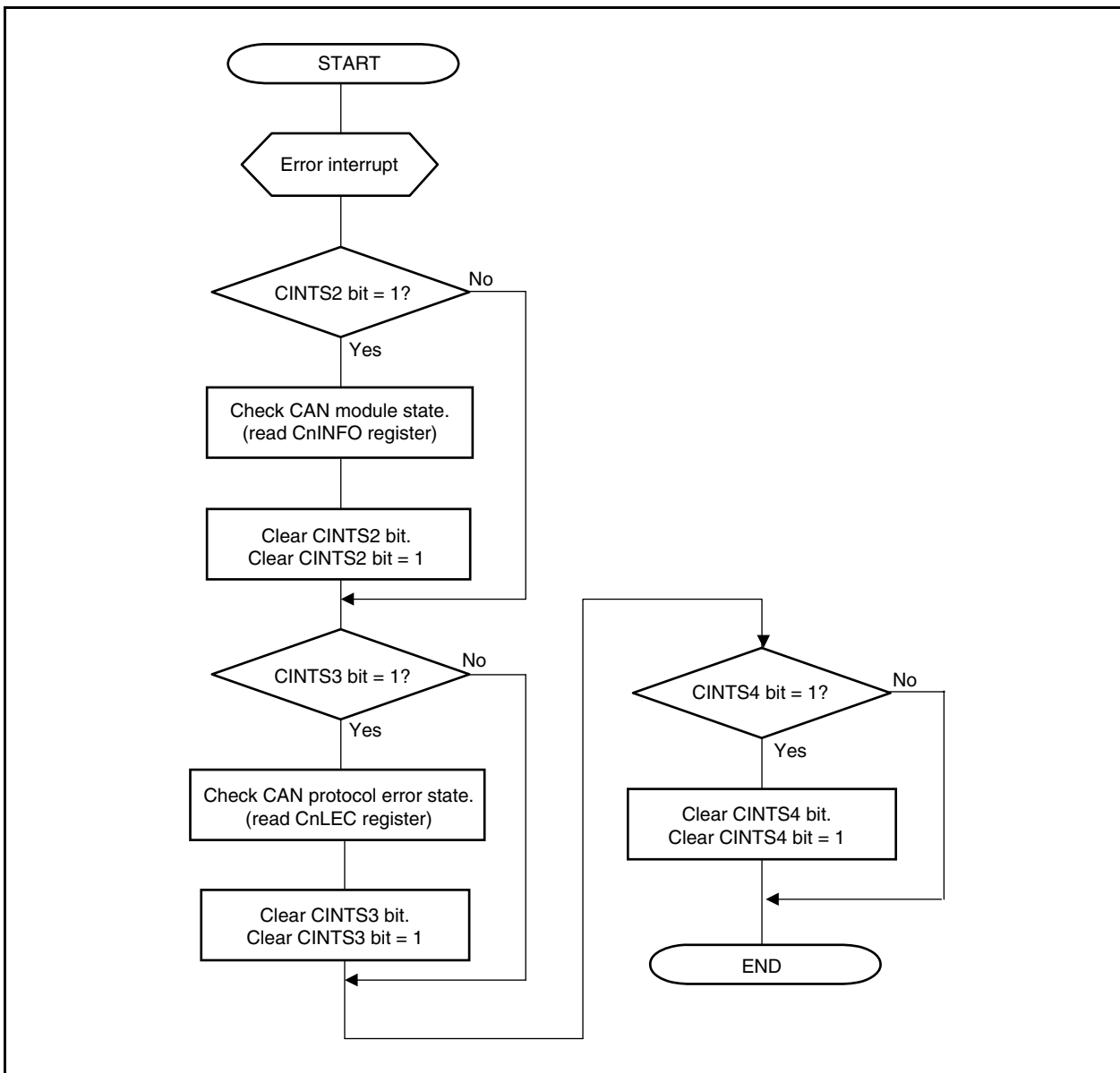

Figure 21-59. Setting CPU Standby (from CAN Sleep Mode)

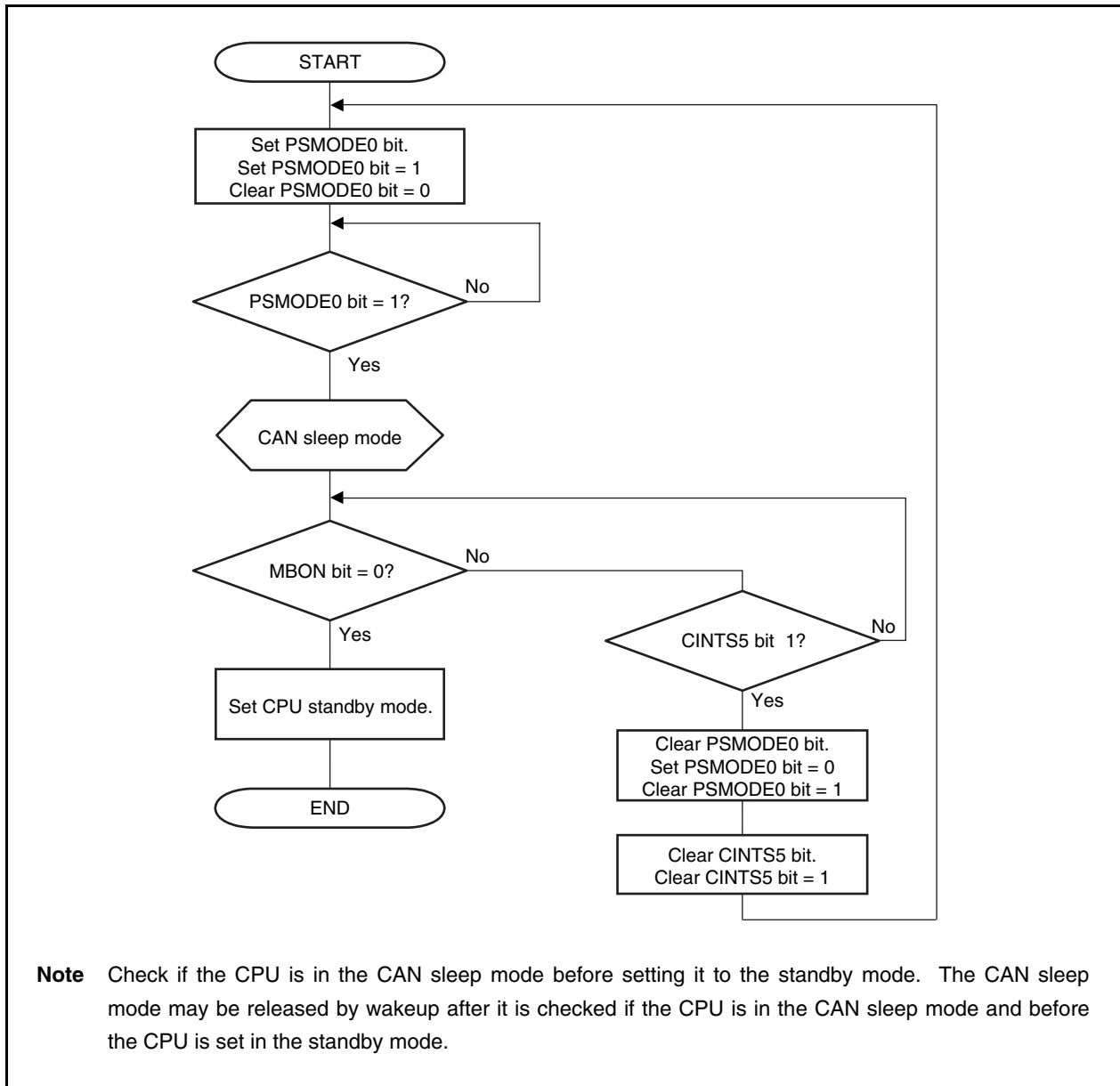
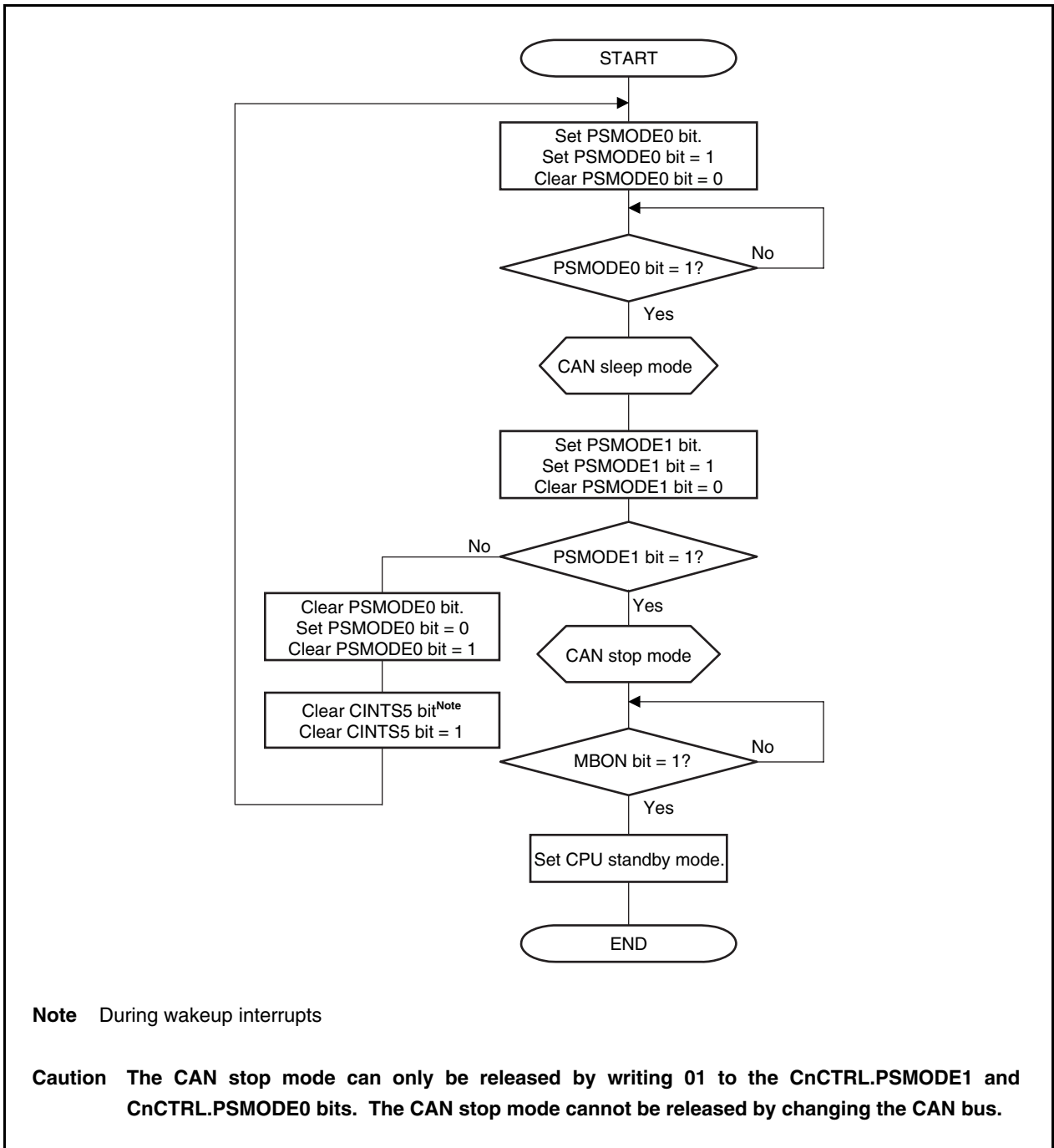

Figure 21-60. Setting CPU Standby (from CAN Stop Mode)



## CHAPTER 22 DMA FUNCTION (DMA CONTROLLER)

The V850E/SJ3-H and V850E/SK3-H include a direct memory access (DMA) controller (DMAC) that executes and controls DMA transfer.

The DMAC controls data transfer between memory and I/O, between memories, or between I/Os based on DMA requests issued by the on-chip peripheral I/O (serial interface, timer/counter, A/D converter, and key interrupt), interrupts from external input pins, or software triggers (memory refers to internal RAM, external memory, or expanded internal RAM).

### 22.1 Features

- 4 independent DMA channels
- Transfer unit: 8/16 bits
- Maximum transfer count: 65,536 ( $2^{16}$ )
- Transfer type: Two-cycle transfer
- Transfer mode: Single transfer mode
- Transfer requests
  - Request by interrupts from on-chip peripheral I/O (serial interface, timer/counter, A/D converter, and key interrupt) or interrupts from external input pin
  - Requests by software trigger
- Transfer targets
  - Internal RAM ↔ Peripheral I/O
  - Peripheral I/O ↔ Peripheral I/O
  - Internal RAM ↔ External memory
  - External memory ↔ Peripheral I/O
  - External memory ↔ External memory
  - Expanded internal RAM ↔ Peripheral I/O
  - Expanded internal RAM ↔ External memory

22.2 Configuration

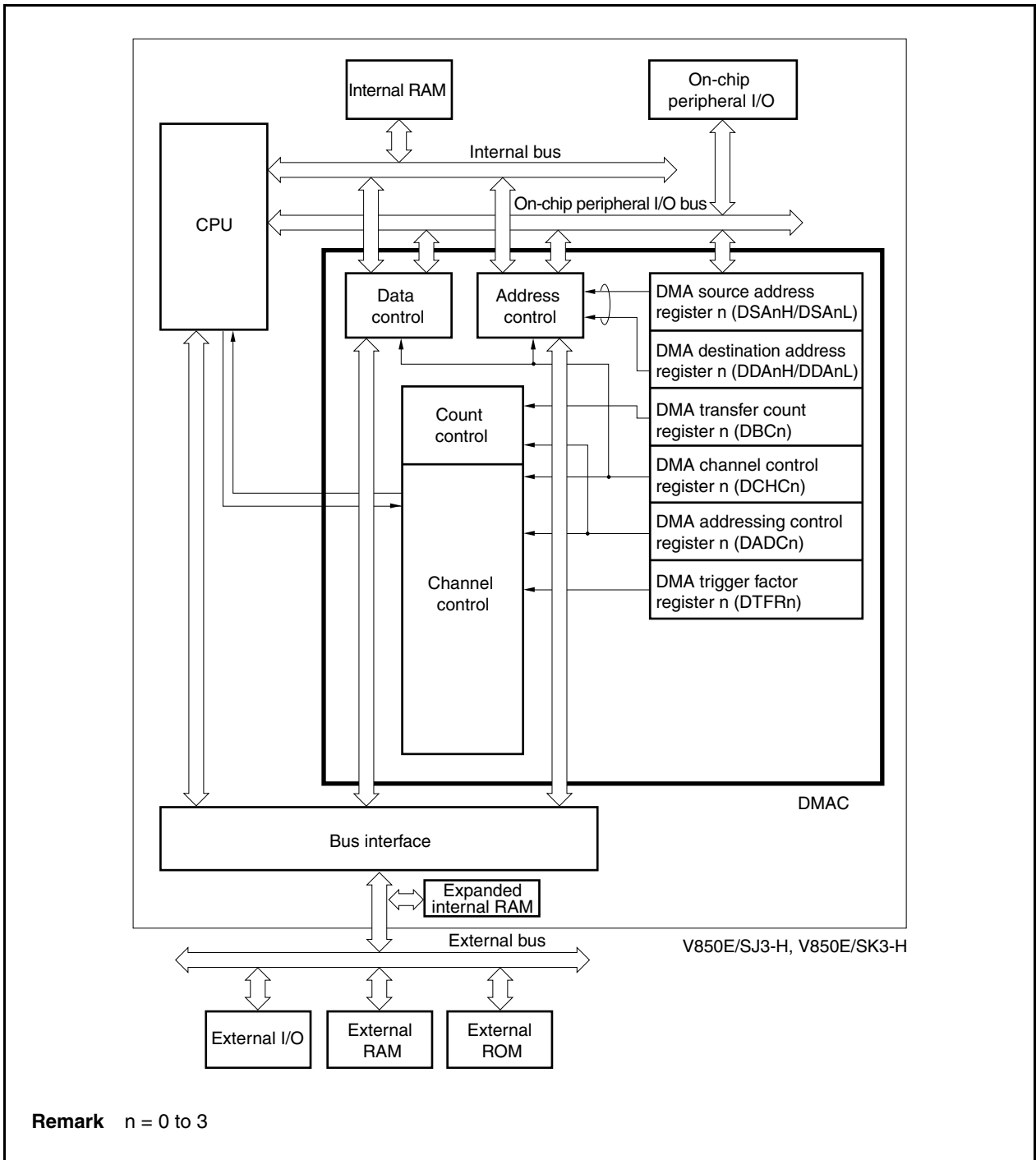

## 22.3 Registers

### (1) DMA source address registers 0 to 3 (DSA0 to DSA3)

The DSA0 to DSA3 registers set the DMA source addresses (26 bits each) for DMA channel n (n = 0 to 3). These registers are divided into two 16-bit registers, DSAnH and DSAnL. These registers can be read or written in 16-bit units.

After reset: Undefined    R/W    Address: DSA0H FFFFF082H, DSA1H FFFFF08AH,  
 DSA2H FFFFF092H, DSA3H FFFFF09AH,  
 DSA0L FFFFF080H, DSA1L FFFFF088H,  
 DSA2L FFFFF090H, DSA3L FFFFF098H

	15	14	13	12	11	10	9	8	7	6	5	4	3	2	1	0
DSAnH (n = 0 to 3)	IR	0	0	0	0	0	SA25	SA24	SA23	SA22	SA21	SA20	SA19	SA18	SA17	SA16

	15	14	13	12	11	10	9	8	7	6	5	4	3	2	1	0
DSAnL (n = 0 to 3)	SA15	SA14	SA13	SA12	SA11	SA10	SA9	SA8	SA7	SA6	SA5	SA4	SA3	SA2	SA1	SA0

IR	Specification of DMA transfer source
0	External memory, on-chip peripheral I/O, or expanded internal RAM
1	Internal RAM

SA25 to SA16	Set the address (A25 to A16) of the DMA transfer source (default value is undefined). During DMA transfer, the next DMA transfer source address is held. When DMA transfer is completed, the DMA address set first is held.
--------------	---

SA15 to SA0	Set the address (A15 to A0) of the DMA transfer source (default value is undefined). During DMA transfer, the next DMA transfer source address is held. When DMA transfer is completed, the DMA address set first is held.
-------------	--

- Cautions**
- Be sure to clear bits 14 to 10 of the DSAnH register to 0.
  - Set the DSAnH and DSAnL registers at the following timing when DMA transfer is disabled (DCHCn.Enn bit = 0).
    - Period from after reset to start of first DMA transfer
    - Period from after channel initialization by DCHCn.INITn bit to start of DMA transfer
    - Period from after completion of DMA transfer (DCHCn.TCn bit = 1) to start of the next DMA transfer
  - When the value of the DSAn register is read, two 16-bit registers, DSAnH and DSAnL, are read. If reading and updating conflict, the value being updated may be read (see 22.13 Cautions).
  - Following reset, set the DSAnH, DSAnL, DDAnH, DDAnL, and DBCn registers before starting DMA transfer. If these registers are not set, the operation when DMA transfer is started is not guaranteed.

**(2) DMA destination address registers 0 to 3 (DDA0 to DDA3)**

The DDA0 to DDA3 registers set the DMA destination address (26 bits each) for DMA channel n (n = 0 to 3). These registers are divided into two 16-bit registers, DDAnH and DDAnL. These registers can be read or written in 16-bit units.

After reset: Undefined R/W Address: DDA0H FFFFFFF086H, DDA1H FFFFFFF08EH,  
 DDA2H FFFFFFF096H, DDA3H FFFFFFF09EH,  
 DDA0L FFFFFFF084H, DDA1L FFFFFFF08CH,  
 DDA2L FFFFFFF094H, DDA3L FFFFFFF09CH

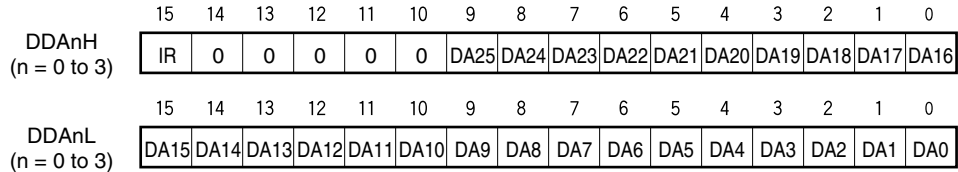

IR	Specification of DMA transfer destination
0	External memory, on-chip peripheral I/O, or expanded internal RAM
1	Internal RAM

DA25 to DA16	Set an address (A25 to A16) of DMA transfer destination (default value is undefined). During DMA transfer, the next DMA transfer destination address is held. When DMA transfer is completed, the DMA transfer source address set first is held.
--------------	--

DA15 to DA0	Set an address (A15 to A0) of DMA transfer destination (default value is undefined). During DMA transfer, the next DMA transfer destination address is held. When DMA transfer is completed, the DMA transfer source address set first is held.
-------------	---

- Cautions**
1. Be sure to clear bits 14 to 10 of the DDAnH register to 0.
  2. Set the DDAnH and DDAnL registers at the following timing when DMA transfer is disabled (DHCn.Enn bit = 0).
    - Period from after reset to start of first DMA transfer
    - Period from after channel initialization by DHCn.INITn bit to start of DMA transfer
    - Period from after completion of DMA transfer (DHCn.TCn bit = 1) to start of the next DMA transfer
  3. When the value of the DDAn register is read, two 16-bit registers, DDAnH and DDAnL, are read. If reading and updating conflict, a value being updated may be read (see 22.13 Cautions).
  4. Following reset, set the DSAnH, DSAnL, DDAnH, DDAnL, and DBCn registers before starting DMA transfer. If these registers are not set, the operation when DMA transfer is started is not guaranteed.

**(3) DMA transfer count registers 0 to 3 (DBC0 to DBC3)**

The DBC0 to DBC3 registers are 16-bit registers that set the transfer count for DMA channel n (n = 0 to 3). These registers hold the remaining transfer count during DMA transfer.

These registers are decremented by 1 per one transfer regardless of the transfer data unit (8/16 bits), and the transfer is terminated if a borrow occurs.

These registers can be read or written in 16-bit units.

After reset: Undefined    R/W    Address: DBC0 FFFF0C0H, DBC1 FFFF0C2H,  
 DBC2 FFFF0C4H, DBC3 FFFF0C6H

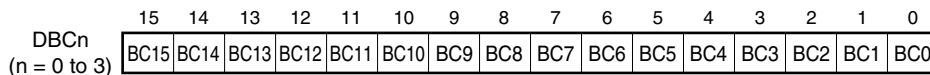

BC15 to BC0	Transfer count setting or remaining transfer count during DMA transfer
0000H	Transfer count 1 or remaining transfer count
0001H	Transfer count 2 or remaining transfer count
:	:
FFFFH	Transfer count 65,536 (2 <sup>16</sup> ) or remaining transfer count
The number of transfer data set first is held when DMA transfer is complete.	

**Cautions 1. Set the DBC<sub>n</sub> register at the following timing when DMA transfer is disabled (DCHC<sub>n</sub>.Enn bit = 0).**

- Period from after reset to start of first DMA transfer
- Period from after channel initialization by DCHC<sub>n</sub>.INIT<sub>n</sub> bit to start of DMA transfer
- Period from after completion of DMA transfer (DCHC<sub>n</sub>.TC<sub>n</sub> bit = 1) to start of the next DMA transfer

**2. Following reset, set the DSAnH, DSAnL, DDAnH, DDAnL, and DBC<sub>n</sub> registers before starting DMA transfer. If these registers are not set, the operation when DMA transfer is started is not guaranteed.**



**(4) DMA addressing control registers 0 to 3 (DADC0 to DADC3)**

The DADC0 to DADC3 registers are 16-bit registers that control the DMA transfer mode for DMA channel n (n = 0 to 3).

These registers can be read or written in 16-bit units.

Reset sets these registers to 0000H.

After reset: 0000H    R/W    Address: DADC0 FFFFF0D0H, DADC1 FFFFF0D2H,  
DADC2 FFFFF0D4H, DADC3 FFFFF0D6H

	15	14	13	12	11	10	9	8
DADCn	0	DS0	0	0	0	0	0	0
(n = 0 to 3)								
	7	6	5	4	3	2	1	0
	SAD1	SAD0	DAD1	DAD0	0	0	0	0

DS0	Setting of transfer data size
0	8 bits
1	16 bits

SAD1	SAD0	Setting of count direction of the transfer source address
0	0	Increment
0	1	Decrement
1	0	Fixed
1	1	Setting prohibited

DAD1	DAD0	Setting of count direction of the destination address
0	0	Increment
0	1	Decrement
1	0	Fixed
1	1	Setting prohibited

- Cautions**
- Be sure to clear bits 15, 13 to 8, and 3 to 0 of the DADCn register to 0.
  - Set the DADCn register at the following timing when DMA transfer is disabled (DCHCn.Enn bit = 0).
    - Period from after reset to start of first DMA transfer
    - Period from after channel initialization by DCHCn.INITn bit to start of DMA transfer
    - Period from after completion of DMA transfer (DCHCn.TCn bit = 1) to start of the next DMA transfer
  - The DS0 bit specifies the size of the transfer data, and does not control bus sizing. If 8-bit data (DS0 bit = 0) is set, therefore, the lower data bus is not always used.
  - If the transfer data size is set to 16 bits (DS0 bit = 1), transfer cannot be started from an odd address. Transfer is always started from an address with the first bit of the lower address aligned to 0.
  - If DMA transfer is executed on an on-chip peripheral I/O register (as the transfer source or destination), be sure to specify the same transfer size as the register size. For example, to execute DMA transfer on an 8-bit register, be sure to specify 8-bit transfer.

**(5) DMA channel control registers 0 to 3 (DCHC0 to DCHC3)**

The DCHC0 to DCHC3 registers are 8-bit registers that control the DMA transfer operating mode for DMA channel n.

These registers can be read or written in 8-bit or 1-bit units. (However, bit 7 is read-only and bits 1 and 2 are write-only. If bit 1 or 2 is read, the read value is always 0.)

Reset sets these registers to 00H.

After reset: 00H    R/W    Address: DCHC0 FFFF0E0H, DCHC1 FFFF0E2H,  
DCHC2 FFFF0E4H, DCHC3 FFFF0E6H

	<7>	6	5	4	3	<2>	<1>	<0>
DCHCn (n = 0 to 3)	TCn <sup>Note 1</sup>	0	0	0	0	INITn <sup>Note 2</sup>	STGn <sup>Note 2</sup>	Enn

TCn <sup>Note 1</sup>	Status flag indicates whether DMA transfer through DMA channel n has completed or not
0	DMA transfer had not completed.
1	DMA transfer had completed.
It is set to 1 on the last DMA transfer and cleared to 0 when it is read.	

INITn <sup>Note 2</sup>	If the INITn bit is set to 1 with DMA transfer disabled (Enn bit = 0), the DMA transfer status can be initialized. When re-setting the DMA transfer status (re-setting the DDAnH, DDAnL, DSAnH, DSAnL, DBCn, and DADCn registers) before DMA transfer is completed (before the TCn bit is set to 1), be sure to initialize the DMA channel. When initializing the DMA controller, however, be sure to observe the procedure described in <b>22.13 Cautions</b> .
-------------------------	--

STGn <sup>Note 2</sup>	This is a software startup trigger of DMA transfer. If this bit is set to 1 in the DMA transfer enable state (TCn bit = 0, Enn bit = 1), DMA transfer is started.
------------------------	--

Enn	Setting of whether DMA transfer through DMA channel n is to be enabled or disabled
0	DMA transfer disabled
1	DMA transfer enabled
DMA transfer is enabled when the Enn bit is set to 1. When DMA transfer is completed (when a terminal count is generated), this bit is automatically cleared to 0. To abort DMA transfer, clear the Enn bit to 0 by software. To resume, set the Enn bit to 1 again. When stopping DMA transfer (forcibly terminating, reexecuting, aborting or resuming), however, be sure to observe the procedure described in <b>22.13 Cautions</b> .	

- Notes**
1. The TCn bit is read-only.
  2. The INITn and STGn bits are write-only.

- Cautions**
1. Be sure to clear bits 6 to 3 of the DCHCn register to 0.
  2. When DMA transfer is completed (when a terminal count is generated), the Enn bit is cleared to 0 and then the TCn bit is set to 1. If the DCHCn register is read while its bits are being updated, a value indicating “transfer not completed and transfer is disabled” (TCn bit = 0 and Enn bit = 0) may be read.

**(6) DMA trigger factor registers 0 to 3 (DTFR0 to DTFR3)**

The DTFR0 to DTFR3 registers are 8-bit registers that control the DMA transfer start trigger via interrupt request signals from on-chip peripheral I/O.

The interrupt request signals set by these registers serve as DMA transfer start factors.

These registers can be read or written in 8-bit units. However, DF<sub>n</sub> bit can be read or written in 1-bit units.

Reset sets these registers to 00H.

(1/2)

After reset: 00H    R/W    Address: DTFR0 FFFFF810H, DTFR1 FFFFF812H,  
DTFR2 FFFFF814H, DTFR3 FFFFF816H

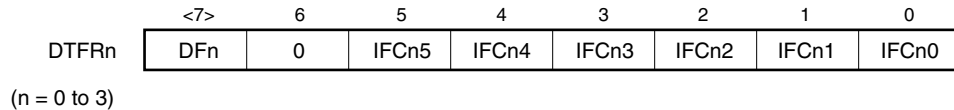

DF <sub>n</sub> <sup>Note</sup>	DMA transfer request status flag
0	No DMA transfer request
1	DMA transfer request

**Note** Do not set the DF<sub>n</sub> bit to 1 by software. Write 0 to this bit to clear a DMA transfer request if an interrupt that is specified as the cause of starting DMA transfer occurs while DMA transfer is disabled.

**Cautions 1. Set the IFC<sub>n5</sub> to IFC<sub>n0</sub> bits at the following timing when DMA transfer is disabled (DCHC<sub>n</sub>.Enn bit = 0).**

- Period from after reset to start of first DMA transfer
- Period from after channel initialization by DCHC<sub>n</sub>.INIT<sub>n</sub> bit to start of DMA transfer
- Period from after completion of DMA transfer (DCHC<sub>n</sub>.TC<sub>n</sub> bit = 1) to start of the next DMA transfer

**Cautions 2.** Be sure to follow the steps below when changing the DTFRn register settings.

- When the values to be set to bits IFCn5 to IFCn0 are not set to bits IFCm5 to IFCm0 of another channel ( $n = 0$  to  $3$ ,  $m = 0$  to  $3$ ,  $n \neq m$ )
    - <1> Stop the DMA<sub>n</sub> operation of the channel to be rewritten (DCHCn.Enn bit = 0).
    - <2> Change the DTFRn register settings. (Be sure to set DF<sub>n</sub> bit = 0 and change the settings in the 8-bit manipulation.)
    - <3> Confirm that DF<sub>n</sub> bit = 0. (Stop the interrupt generation source operation beforehand.)
    - <4> Enable the DMA<sub>n</sub> operation (Enn bit = 1).
  - When the values to be set to bits IFCn5 to IFCn0 are set to bits IFCm5 to IFCm0 of another channel ( $n = 0$  to  $3$ ,  $m = 0$  to  $3$ ,  $n \neq m$ )
    - <1> Stop the DMA<sub>n</sub> operation of the channel to be rewritten (DCHCn.Enn bit = 0).
    - <2> Stop the DMA<sub>m</sub> operation of the channel where the same values are set to bits IFCm5 to IFCm0 as the values to be used to rewrite bits IFCn5 to IFCn0 (DCHCm.Emm bit = 0).
    - <3> Change the DTFRn register settings. (Be sure to set DF<sub>n</sub> bit = 0 and change the settings in the 8-bit manipulation.)
    - <4> Confirm that bits DF<sub>n</sub> and DF<sub>m</sub> = 0. (Stop the interrupt generation source operation beforehand.)
    - <5> Enable the DMA<sub>n</sub> operation (bits Enn and Emm = 1).
3. An interrupt request that is generated in the standby mode (IDEL1, IDLE2, STOP, or sub-IDLE mode) does not start the DMA transfer cycle (nor is the DF<sub>n</sub> bit set to 1).
  4. If a DMA start factor is selected by the IFCn5 to IFCn0 bits, the DF<sub>n</sub> bit is set to 1 when an interrupt occurs from the selected on-chip peripheral I/O, regardless of whether the DMA transfer is enabled or disabled. If DMA is enabled in this status, DMA transfer is immediately started.
  5. In the V850E/SK3-H, when using UARTA1 and I<sup>2</sup>C02 at the same time, and using the INTUA1R signal as the DMA transfer start factor, set the DTFROB1 bit of option byte 0000007AH (refer to CHAPTER 33 OPTION BYTE FUNCTION) to 1. In this case, the INTIIC2 signal cannot be used as the DMA transfer start factor.
  6. In the V850E/SK3-H, when using UARTA2 and I<sup>2</sup>C00 at the same time, and using the INTUA2R signal as the DMA transfer start factor, set the DTFROB1 bit of option byte 0000007AH (refer to CHAPTER 33 OPTION BYTE FUNCTION) to 1. In this case, the INTIIC0 signal cannot be used as the DMA transfer start factor.

**Remark** For the IFCn5 to IFCn0 bits, see Table 22-1 DMA Transfer Start Factors.

Table 22-1. DMA Transfer Start Factors (1/2)

DTFR Register						Option Byte 0000007AH <sup>Note</sup>		Interrupt Source
IFCn5	IFCn4	IFCn3	IFCn2	IFCn1	IFCn0	DTFROB1	DTFROB0	
0	0	0	0	0	0	X	X	DMA request by interrupt disabled
0	0	0	0	0	1	X	X	INTP0
0	0	0	0	1	0	X	X	INTP1
0	0	0	0	1	1	X	X	INTP2
0	0	0	1	0	0	X	X	INTP3
0	0	0	1	0	1	X	X	INTP4
0	0	0	1	1	0	X	X	INTP5
0	0	0	1	1	1	X	X	INTP6
0	0	1	0	0	0	X	X	INTP7
0	0	1	0	0	1	X	0	INTTQ0OV
							1	NTUB0TIR
0	0	1	0	1	0	X	X	INTTQ0CC0
0	0	1	0	1	1	X	X	INTTQ0CC1
0	0	1	1	0	0	X	X	INTTQ0CC2
0	0	1	1	0	1	X	X	INTTQ0CC3
0	0	1	1	1	0	X	0	INTTP0OV
							1	INTUB0TIT
0	0	1	1	1	1	X	X	INTTP0CC0
0	1	0	0	0	0	X	X	INTTP0CC1
0	1	0	0	0	1	X	0	INTTP1OV
							1	INTUB1TIR
0	1	0	0	1	0	X	X	INTTP1CC0
0	1	0	0	1	1	X	X	INTTP1CC1
0	1	0	1	0	0	X	0	INTTP2OV
							1	INTUB1TIT
0	1	0	1	0	1	X	X	INTTP2CC0
0	1	0	1	1	0	X	X	INTTP2CC1
0	1	0	1	1	1	X	X	INTTP3CC0
0	1	1	0	0	0	X	X	INTTP3CC1
0	1	1	0	0	1	X	X	INTTP4CC0
0	1	1	0	1	0	X	X	INTTP4CC1
0	1	1	0	1	1	X	X	INTTP5CC0
0	1	1	1	0	0	X	X	INTTP5CC1
0	1	1	1	0	1	X	X	INTTM0EQ0
0	1	1	1	1	0	X	X	INTCB0R/INTIIC1
0	1	1	1	1	1	X	X	INTCB0T
1	0	0	0	0	0	X	X	INTCB1R
1	0	0	0	0	1	X	X	INTCB1T
1	0	0	0	1	0	X	X	INTCB2R
1	0	0	0	1	1	X	X	INTCB2T
1	0	0	1	0	0	X	X	INTCB3R
1	0	0	1	0	1	X	X	INTCB3T
1	0	0	1	1	0	X	X	INTUA0R/INTCB4R
1	0	0	1	1	1	X	X	INTUA0T/INTCB4T

**Note** For details, refer to **CHAPTER 33 OPTION BYTE FUNCTION**.

**Remark** n = 0 to 3

Table 22-1. DMA Transfer Start Factors (2/2)

DTFR Register						Option Byte 000007AH <sup>Note 1</sup>		Interrupt Source
IFCn5	IFCn4	IFCn3	IFCn2	IFCn1	IFCn0	DTFROB1	DTFROB0	
1	0	1	0	0	0	0	X	INTUA1R/INTIIC2
						1		INTUA1R
1	0	1	0	0	1	X	X	INTUA1T
1	0	1	0	1	0	0	X	INTUA2R/INTIIC0
						1		INTUA2R
1	0	1	0	1	1	X	X	INTUA2T
1	0	1	1	0	0	X	X	INTAD
1	0	1	1	0	1	X	0	INTKR
							1	INTTM1EQ0
<R>	0	1	1	1	0	X	0	INTERR
							1	INTCE0T <sup>Note 2</sup>
<R>	0	1	1	1	1	X	0	INTSTA
							1	INTCE1T <sup>Note 2</sup>
1	1	0	0	0	0	X	X	INTIE1
1	1	0	0	0	1	X	0	INTP8
							1	INTTM2EQ0
1	1	0	0	1	0	X	X	INTTP6CC0
1	1	0	0	1	1	X	X	INTTP6CC1
1	1	0	1	0	0	X	X	INTTP7CC0
1	1	0	1	0	1	X	X	INTTP7CC1
1	1	0	1	1	0	X	X	INTTP8CC0
1	1	0	1	1	1	X	X	INTTP8CC1
1	1	1	0	0	0	X	X	INTCB5R
1	1	1	0	0	1	X	X	INTCB5T
1	1	1	0	1	0	X	X	INTUA3R
1	1	1	0	1	1	X	X	INTUA3T
1	1	1	1	0	0	X	X	INTUA4R
1	1	1	1	0	1	X	X	INTUA4T
1	1	1	1	1	0	X	X	INTUA5R
1	1	1	1	1	1	X	X	INTUA5T

**Notes** 1. For details, refer to **CHAPTER 33 OPTION BYTE FUNCTION**.

<R> 2. Not available in the  $\mu$ PD70F3931 (V850E/SJ3-H), 70F3932 (V850E/SJ3-H), and 70F3933 (V850E/SJ3-H)

**Remark** n = 0 to 3

## 22.4 Transfer Targets

Table 22-2 shows the relationship between the transfer targets (√: Transfer enabled, ×: Transfer disabled).

**Table 22-2. Relationship Between Transfer Targets**

		Transfer Destination				
		Internal ROM	On-Chip Peripheral I/O	Internal RAM	External Memory	Expanded Internal RAM
Source	On-chip peripheral I/O	×	√	√	√	√
	Internal RAM	×	√	×	√	×
	External memory	×	√	√	√	√
	Expanded internal RAM	×	√	×	√	×
	Internal ROM	×	×	×	×	×

**Caution** The operation is not guaranteed for combinations of transfer destination and source marked with “×” in Table 22-2.

## 22.5 Transfer Modes

Single transfer is supported as the transfer mode.

In single transfer mode, the bus is released at each byte/halfword transfer. If there is a subsequent DMA transfer request, transfer is performed again once. This operation continues until a terminal count occurs.

When the DMAC has released the bus, if another higher priority DMA transfer request is issued, the higher priority DMA request always takes precedence.

If a new transfer request of the same channel and a transfer request of another channel with a lower priority are generated in a transfer cycle, DMA transfer of the channel with the lower priority is executed after the bus is released to the CPU (the new transfer request of the same channel is ignored in the transfer cycle).

## 22.6 Transfer Types

As a transfer type, the 2-cycle transfer is supported.

In two-cycle transfer, data transfer is performed in two cycles, a read cycle and a write cycle.

In the read cycle, the transfer source address is output and reading is performed from the source to the DMAC. In the write cycle, the transfer destination address is output and writing is performed from the DMAC to the destination.

An idle cycle of one clock is always inserted between a read cycle and a write cycle. If the data bus width differs between the transfer source and destination for DMA transfer of two cycles, the operation is performed as follows.

<16-bit data transfer>

<1> Transfer from 32-bit bus → 16-bit bus

A read cycle (the higher 16 bits are in a high-impedance state) is generated, followed by generation of a write cycle (16 bits).

<2> Transfer from 16-/32-bit bus to 8-bit bus

A 16-bit read cycle is generated once, and then an 8-bit write cycle is generated twice.

<3> Transfer from 8-bit bus to 16-/32-bit bus

An 8-bit read cycle is generated twice, and then a 16-bit write cycle is generated once.

<4> Transfer between 16-bit bus and 32-bit bus

A 16-bit read cycle is generated once, and then a 16-bit write cycle is generated once.

For DMA transfer executed to an on-chip peripheral I/O register (transfer source/destination), be sure to specify the same transfer size as the register size. For example, for DMA transfer to an 8-bit register, be sure to specify byte (8-bit) transfer.

**Remark** The bus width of each transfer target (transfer source/destination) is as follows.

- On-chip peripheral I/O: 16-bit bus width
- Internal RAM: 32-bit bus width
- External memory: 8-bit or 16-bit bus width
- Expanded internal RAM: 32-bit bus width



## 22.7 DMA Channel Priorities

The DMA channel priorities are fixed as follows.

DMA channel 0 > DMA channel 1 > DMA channel 2 > DMA channel 3

The priorities are checked for every transfer cycle.

**Caution** If two or more DMA channels are started with the same factor, a DMA channel with a lower priority may be acknowledged earlier than a DMA channel with a higher priority.

## 22.8 Time Related to DMA Transfer

The time required to respond to a DMA request, and the minimum number of clocks required for DMA transfer are shown below.

Single transfer: DMA response time (<1>) + Transfer source memory access (<2>) + 1<sup>Note 1</sup> + Transfer destination memory access (<2>)

DMA Cycle		Minimum Number of Execution Clocks
<1> DMA request response time		4 clocks (MIN.) + Noise elimination time <sup>Note 2</sup>
<2> Memory access	External memory access	Depends on connected memory.
	Internal RAM access	2 clocks <sup>Note 3</sup>
	Peripheral I/O register access	3 clocks + Number of wait cycles specified by VSWC register <sup>Note 4</sup>
	Expanded internal RAM	3 + n clocks <sup>Note 5</sup>

- Notes**
- One clock is always inserted between a read cycle and a write cycle in DMA transfer.
  - If an external interrupt (INTPn) is specified as the trigger to start DMA transfer, noise elimination time is added (n = 0 to 9).
  - Two clocks are required for a DMA cycle.
  - More wait cycles are necessary for accessing a specific peripheral I/O register (for details, see 3.4.9 (2)).
  - Before using the expanded internal RAM, be sure to execute the initial setting of the expanded internal RAM. For details of the expanded internal RAM, see 3.4.4 (6) (b) Initial settings for expanded internal RAM).

**Remark** n: Number of wait cycles inserted by  $\overline{\text{WAIT}}$  pin

## 22.9 DMA Transfer Start Factors

There are two types of DMA transfer start factors, as shown below.

### (1) Request by software

If the STGn bit is set to 1 while the DCHCn.TCn bit = 0 and Enn bit = 1 (DMA transfer enabled), DMA transfer is started.

To request the next DMA transfer cycle immediately after that, confirm, by using the DBCn register, that the preceding DMA transfer cycle has been completed, and set the STGn bit to 1 again (n = 0 to 3).

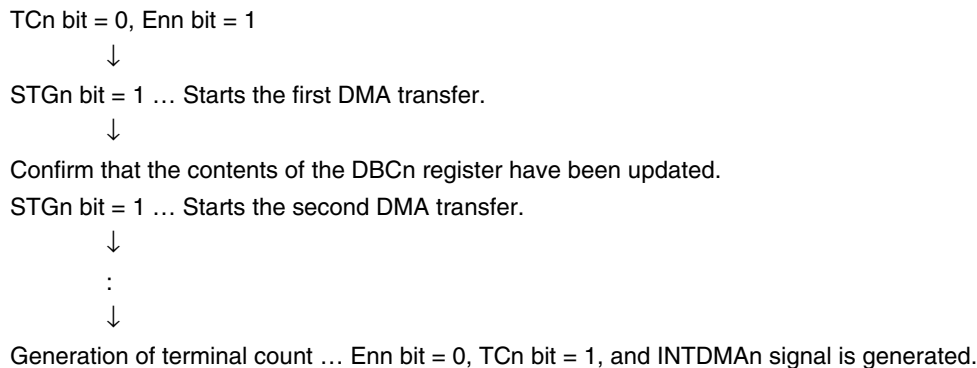

### (2) Request by on-chip peripheral I/O

If an interrupt request is generated from the on-chip peripheral I/O set by the DTFRn register when the DCHCn.TCn bit = 0 and Enn bit = 1 (DMA transfer enabled), DMA transfer is started.

- Cautions**
- Two start factors (software trigger and hardware trigger) cannot be used for one DMA channel. If two start factors are simultaneously generated for one DMA channel, only one of them is valid. The start factor that is valid cannot be identified.**
  - A new transfer request that is generated after the preceding DMA transfer request was generated or in the preceding DMA transfer cycle is ignored (cleared).**
  - The transfer request interval of the same DMA channel varies depending on the setting of bus wait in the DMA transfer cycle, the start status of the other channels, or the external bus hold request. In particular, as described in Caution 2, a new transfer request that is generated for the same channel before the DMA transfer cycle or during the DMA transfer cycle is ignored. Therefore, the transfer request intervals for the same DMA channel must be sufficiently separated by the system. When the software trigger is used, completion of the DMA transfer cycle that was generated before can be checked by updating the DBCn register.**

### 22.10 DMA Abort Factors

DMA transfer is aborted if a bus hold occurs.

The same applies if transfer is executed between the internal memory/on-chip peripheral I/O and internal memory/on-chip peripheral I/O.

When the bus hold is cleared, DMA transfer is resumed.

### 22.11 End of DMA Transfer

When DMA transfer has been completed the number of times set to the DBCn register and when the DCHCn.Enn bit is cleared to 0 and TCn bit is set to 1, a DMA transfer end interrupt request signal (INTDMA<sub>n</sub>) is generated for the interrupt controller (INTC) (n = 0 to 3).

The V850E/SJ3-H and V850E/SK3-H do not output a terminal count signal to an external device. Therefore, confirm completion of DMA transfer by using the DMA transfer end interrupt or polling the TCn bit.

### 22.12 Operation Timing

Figures 22-1 to 22-4 show DMA operation timing.

Figure 22-1. Priority of DMA (1)

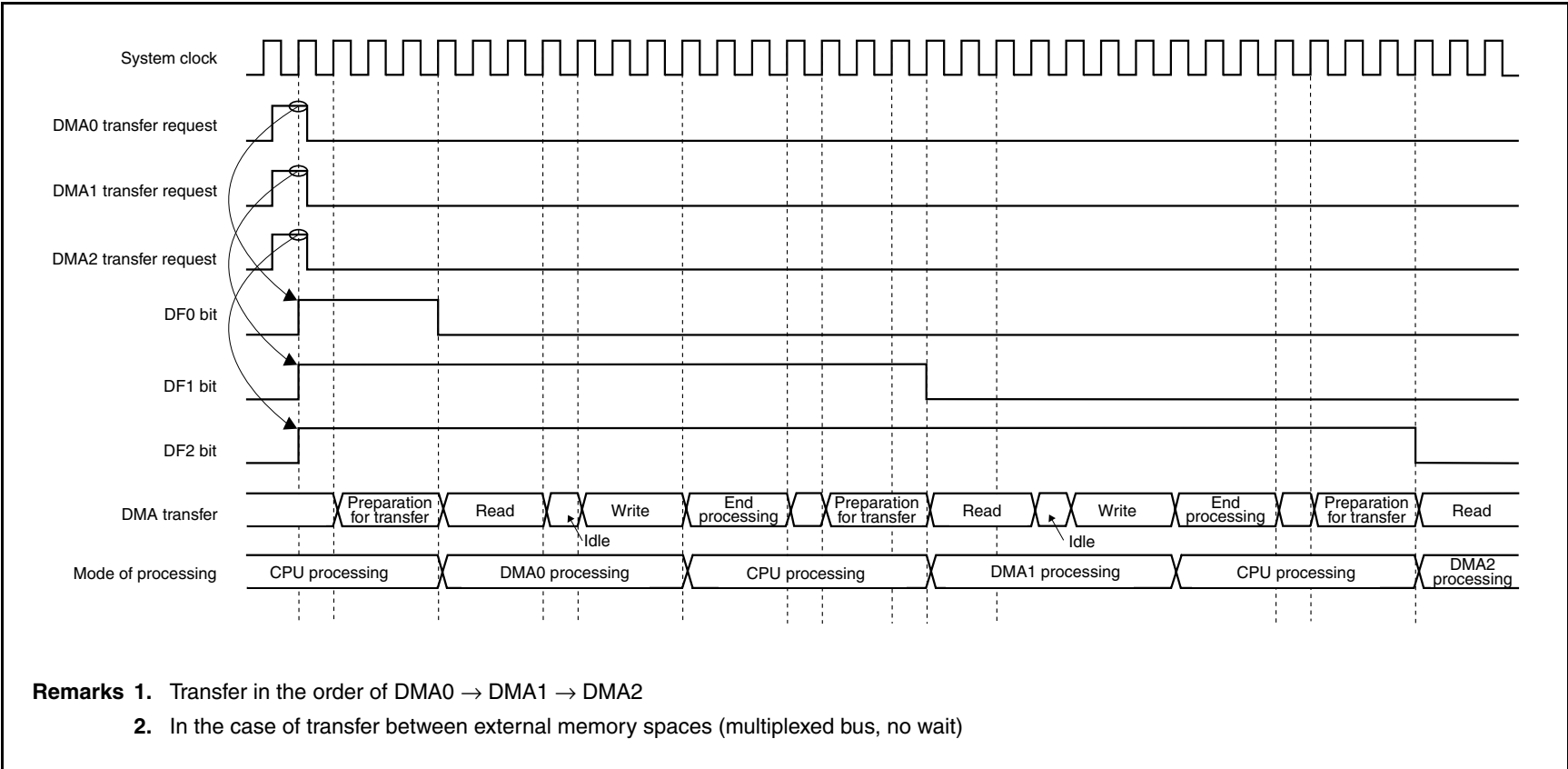

- Remarks**
1. Transfer in the order of DMA0 → DMA1 → DMA2
  2. In the case of transfer between external memory spaces (multiplexed bus, no wait)

Figure 22-2. Priority of DMA (2)

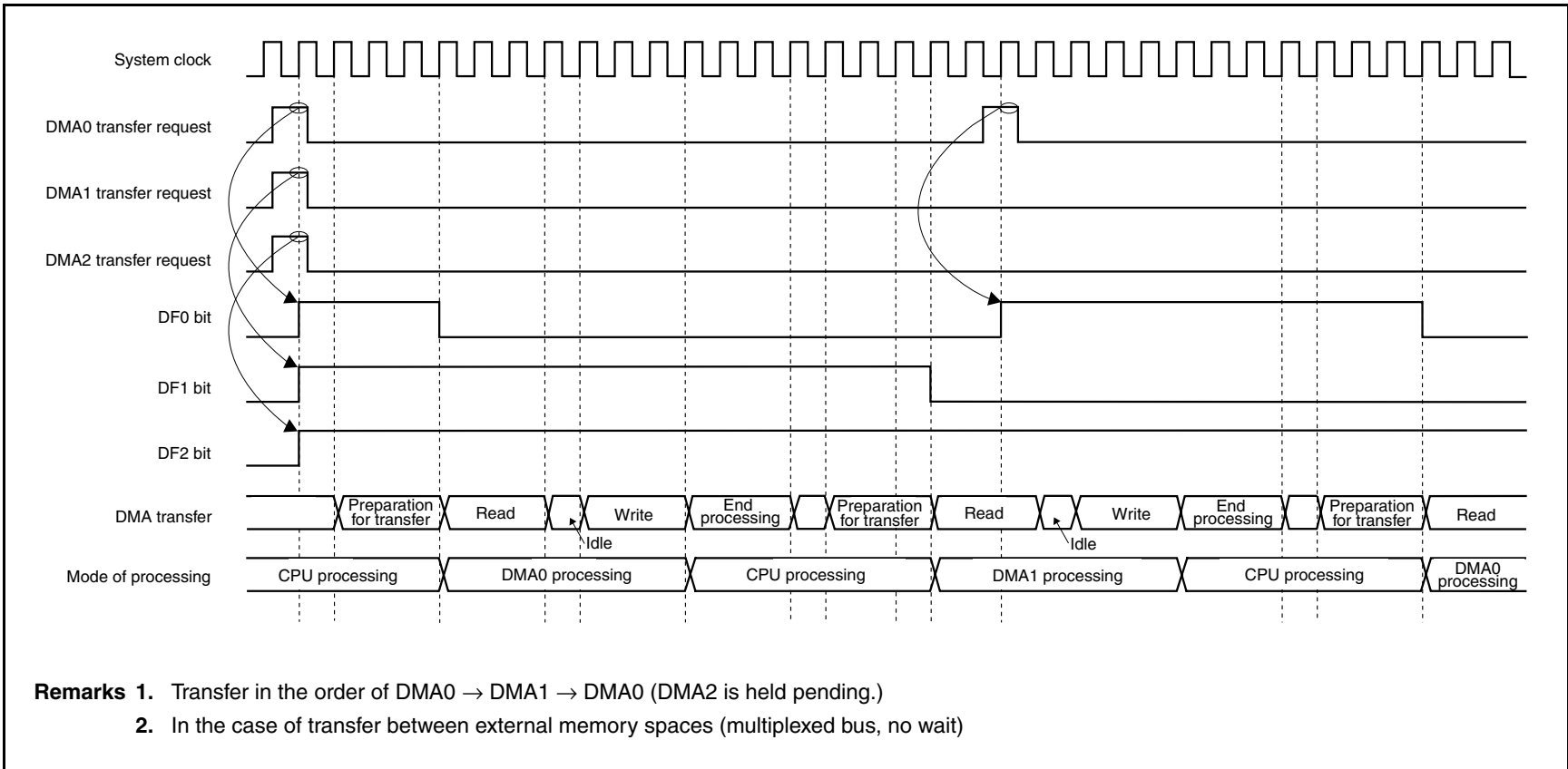

Figure 22-3. Period in Which DMA Transfer Request Is Ignored (1)

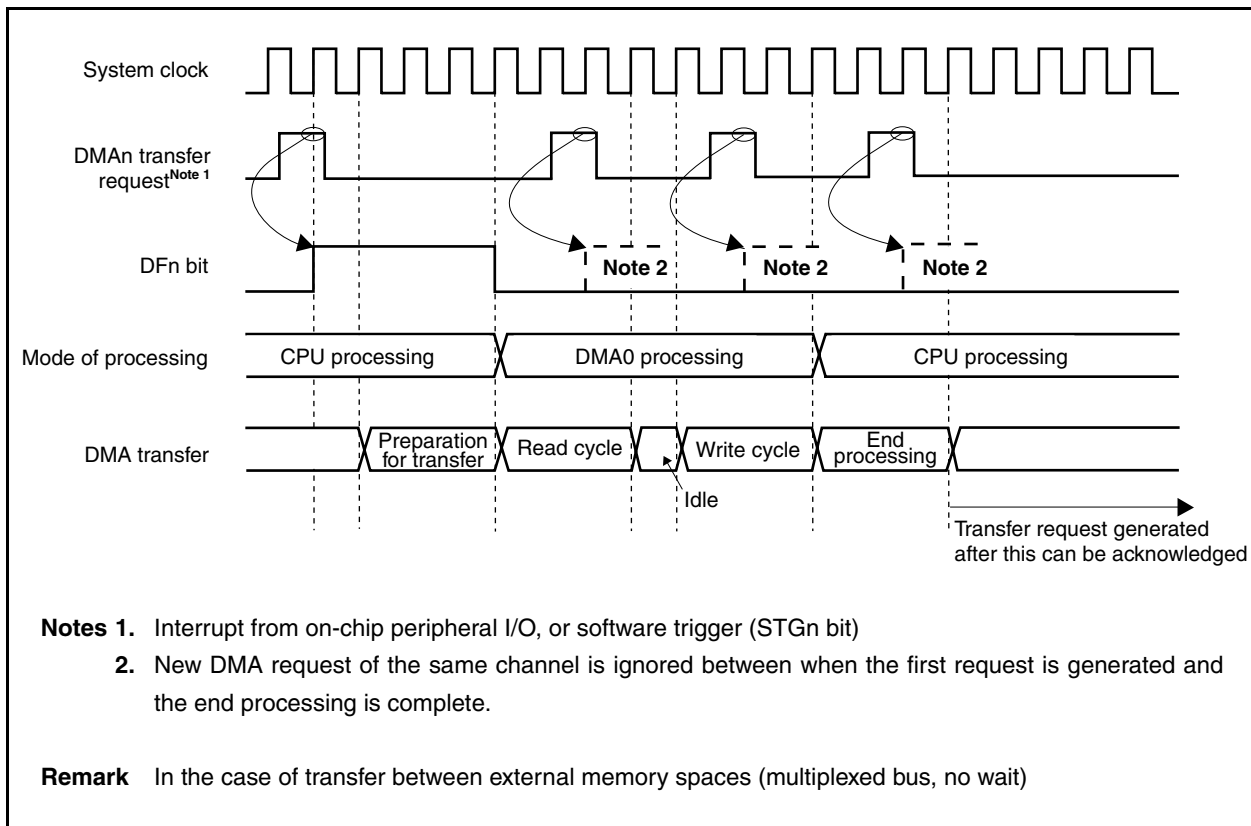
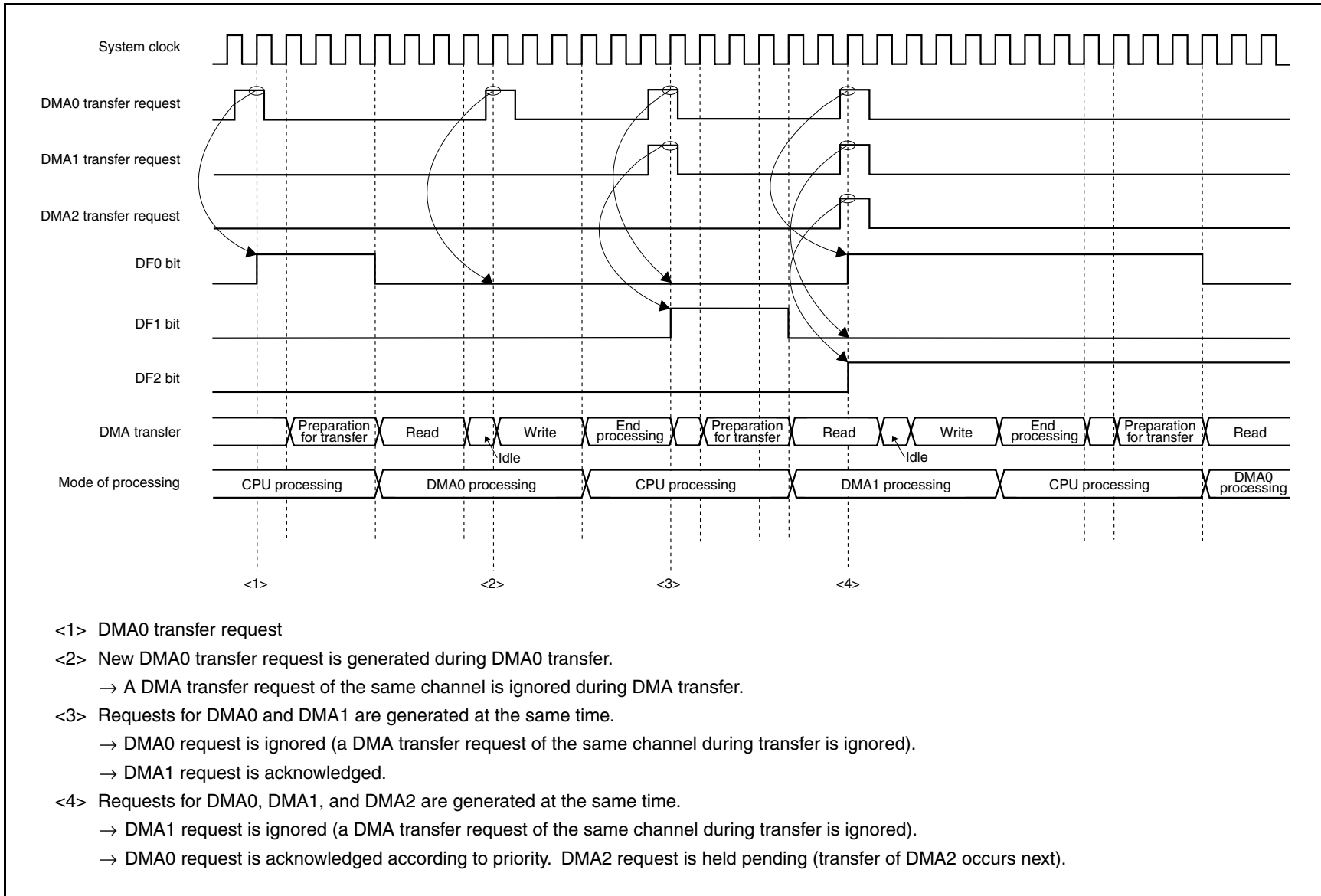

Figure 22-4. Period in Which DMA Transfer Request Is Ignored (2)



## 22.13 Cautions

### (1) Caution for VSWC register

When using the DMAC, be sure to set an appropriate value, in accordance with the operating frequency, to the VSWC register.

When the default value (77H) of the VSWC register is used, or if an inappropriate value is set to the VSWC register, the operation is not correctly performed (for details of the VSWC register, see **3.4.9 (1) (a) System wait control register (VSWC)**).

### (2) Caution for DMA transfer executed on internal RAM

When executing the following instructions located in the internal RAM, do not execute a DMA transfer that transfers data to/from the internal RAM (transfer source/destination), because the CPU may not operate correctly afterward.

- Bit manipulation instruction located in internal RAM (SET1, CLR1, or NOT1)
- Data access instruction to misaligned address located in internal RAM

Conversely, when executing a DMA transfer to transfer data to/from the internal RAM (transfer source/destination), do not execute the above two instructions.

### (3) Caution for reading DCHCn.TCn bit (n = 0 to 3)

When performing a DMA transfer from the internal RAM, if the TCn bit is read by the interrupt servicing routine, either of the following conditions must be satisfied.

- When the TCn bit is read at the start of the interrupt servicing routine, perform the read operation twice consecutively.
- Execute at least one instruction at the start of the interrupt servicing routine to access (read/write) the internal RAM, on-chip peripheral I/O register area, programmable peripheral I/O register area, or external memory area before reading the TCn bit.



**(4) Procedure of stopping DMA transfer (clearing Enn bit)**

Forcibly clearing the Enn bit to 0 during DMA transfer can stop the DMA transfer under execution. To stop the DMA transfer, however, be sure to execute either of the following two procedures. If the Enn bit is cleared to 0 by using a different procedure, the operation is not guaranteed.

**(a) Cancel the all DMA transfers under execution, and retry the DMA transfer from the first step.**

- <1> Suppress a transfer request from the DMA request source (stop the operation of the on-chip peripheral I/O).
- <2> Check that the DMA transfer request is not held pending, by using the DF<sub>n</sub> bit (check if the DF<sub>n</sub> bit = 0).  
If the request is held pending, clear the DF<sub>n</sub> bit to 0.
- <3> If it has been confirmed that no DMA transfer request is held pending, clear the Enn bit to 0 (this operation stops DMA transfer).
- <4> Set the INIT<sub>n</sub> bit to 1 (this operation initializes the status of DMA transfer).

**(b) Stop the DMA transfer under execution, and resume.**

- <1> Suppress a transfer request from the DMA request source (stop the operation of the on-chip peripheral I/O).
- <2> Check that the DMA transfer request is not held pending, by using the DF<sub>n</sub> bit (check if the DF<sub>n</sub> bit = 0).  
If the request is held pending, wait until execution of the pending DMA transfer request is completed.
- <3> If it has been confirmed that no DMA transfer request is held pending, clear the Enn bit to 0 (this operation stops DMA transfer).
- <4> Set the Enn bit to 1 to resume DMA transfer.
- <5> Resume the operation of the DMA request source that has been stopped (start the operation of the on-chip peripheral I/O).

**(5) Memory boundary**

The operation is not guaranteed if the address of the transfer source or destination exceeds the area of the DMA target (external memory, internal RAM, on-chip peripheral I/O, or expanded internal RAM) during DMA transfer.

**(6) Transferring misaligned data**

DMA transfer of misaligned data with a 16-bit bus width is not supported.

If an odd address is specified as the transfer source or destination, the least significant bit of the address is forcibly assumed to be 0.

**(7) Bus arbitration for CPU**

Because the DMA controller has a higher priority bus mastership than the CPU, a CPU access that takes place during DMA transfer is held pending until the DMA transfer cycle is completed and the bus is released to the CPU.

However, the CPU can access the internal ROM and internal RAM for which DMA transfer is not being executed.

- The CPU can access the internal ROM and internal RAM when DMA transfer is being executed between the external memory and on-chip peripheral I/O, and the expanded internal RAM and internal peripheral I/O.
- The CPU can access the internal ROM when DMA transfer is being executed between the on-chip peripheral I/O and internal RAM.

- The CPU can access the internal ROM and internal RAM when DMA transfer is being executed between on-chip peripheral I/Os.

**(8) Registers/bits that must not be rewritten during DMA operation**

Set the following registers at the following timing when a DMA operation is not under execution.

[Registers]

- DSAnH, DSAnL, DDAnH, DDAnL, DBCn, and DADCn registers
- DTFRn.IFCn5 to DTFRn.IFCn0 bits

[Timing of setting]

- Period from after reset to start of the first DMA transfer
- Time after channel initialization to start of DMA transfer
- Period from after completion of DMA transfer (TCn bit = 1) to start of the next DMA transfer

**(9) Be sure to set the following register bits to 0.**

- Bits 14 to 10 of DSAnH register
- Bits 14 to 10 of DDAnH register
- Bits 15, 13 to 8, and 3 to 0 of DADCn register
- Bits 6 to 3 of DCHCn register

**(10) DMA start factor**

Care must be exercised when setting the same start trigger for multiple DMA channels.

If DMA transfers via such DMA channels are activated, the DMA channel with a lower priority may be acknowledged prior to the DMA channel with a higher priority.

**(11) Read values of DSAn and DDAn registers**

Values in the middle of updating may be read from the DSAn and DDAn registers during DMA transfer (n = 0 to 3).

For example, if the DSAnH register and then the DSAnL register are read when the DMA transfer source address (DSAn register) is 0000FFFFH and the count direction is incremental (DADCn.SAD1 and DADCn.SAD0 bits = 00), the value of the DSAn register differs as follows, depending on whether DMA transfer is executed immediately after the DSAnH register is read.

**(a) If DMA transfer does not occur while DSAn register is read**

- <1> Read value of DSAnH register: DSAnH = 0000H
- <2> Read value of DSAnL register: DSAnL = FFFFH

**(b) If DMA transfer occurs while DSAn register is read**

- <1> Read value of DSAnH register: DSAnH = 0000H
- <2> Occurrence of DMA transfer
- <3> Incrementing DSAn register: DSAn = 00010000H
- <4> Read value of DSAnL register: DSAnL = 0000H

## CHAPTER 23 CRC FUNCTION

### 23.1 Functions

- CRC operation circuit for detection of data block errors
- Generation of 16-bit CRC code using a CRC-CCITT ( $X^{16} + X^{12} + X^5 + 1$ ) generation polynomial for blocks of data of any length in 8-bit units
- CRC code is set to the CRC data register each time 1-byte data is transferred to the CRCIN register, after the initial value is set to the CRCD register.

### 23.2 Configuration

The CRC function includes the following hardware.

**Table 23-1. CRC Configuration**

Item	Configuration
Control registers	CRC input register (CRCIN) CRC data register (CRCD)

**Figure 23-1. Block Diagram of CRC Register**

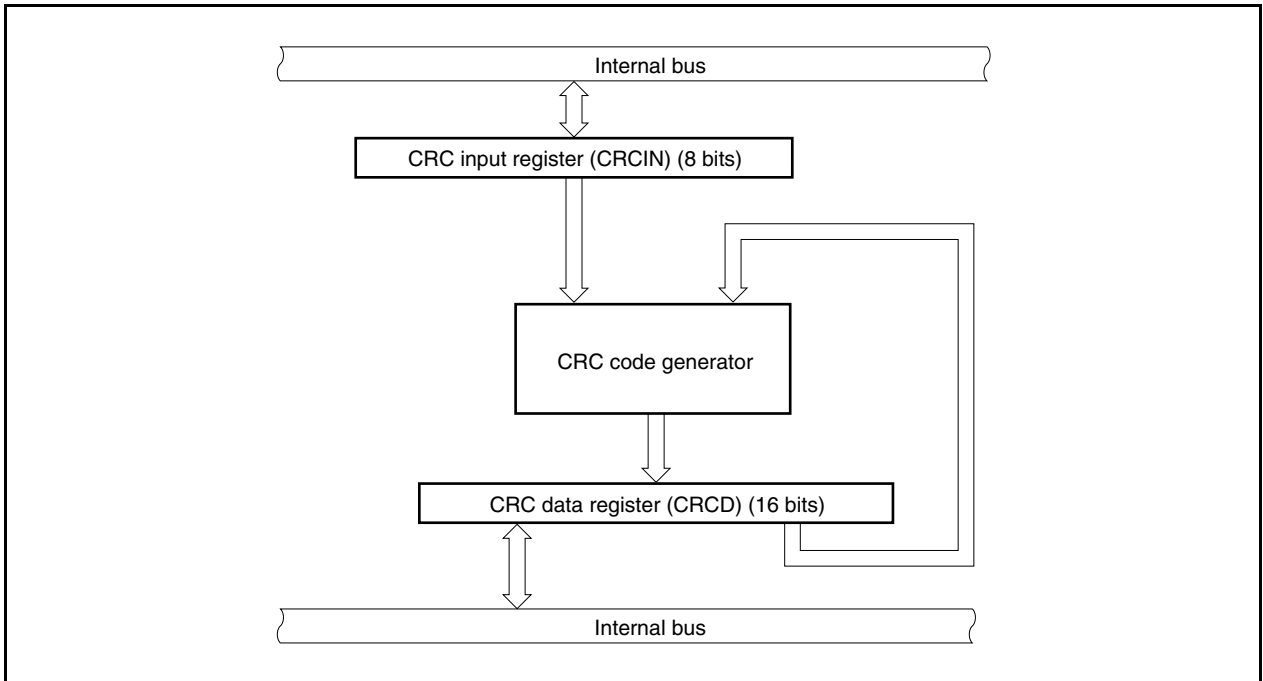

## 23.3 Registers

### (1) CRC input register (CRCIN)

The CRCIN register is an 8-bit register for setting data.

This register can be read or written in 8-bit units.

Reset sets this register to 00H.

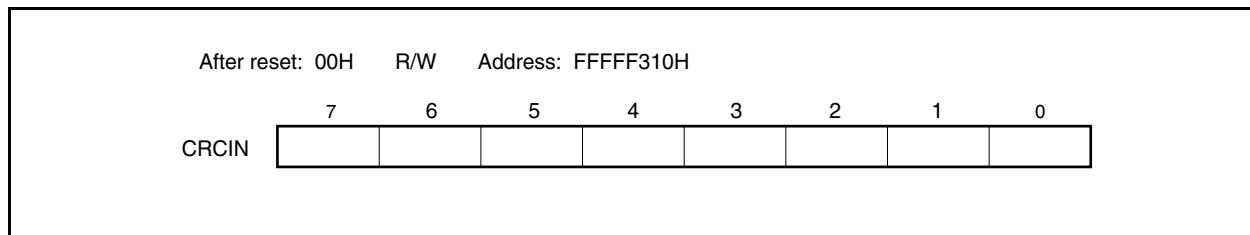

### (2) CRC data register (CRCD)

The CRCD register is a 16-bit register that stores the CRC-CCITT operation results.

This register can be read or written in 16-bit units.

Reset sets this register to 0000H.

**Caution** Accessing the CRCD register is prohibited in the following statuses. For details, refer to 3.4.9 (2) Accessing specific on-chip peripheral I/O registers.

- When the CPU operates with the subclock and the main clock oscillation is stopped
- When the CPU operates with the internal oscillation clock

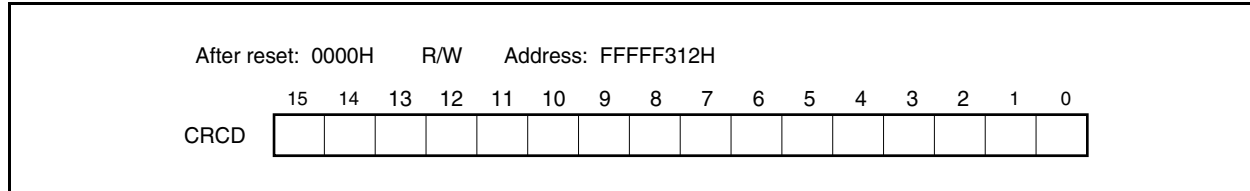

### 23.4 Operation

An example of the CRC operation circuit is shown below.

**Figure 23-2. CRC Operation Circuit Operation Example (LSB First)**

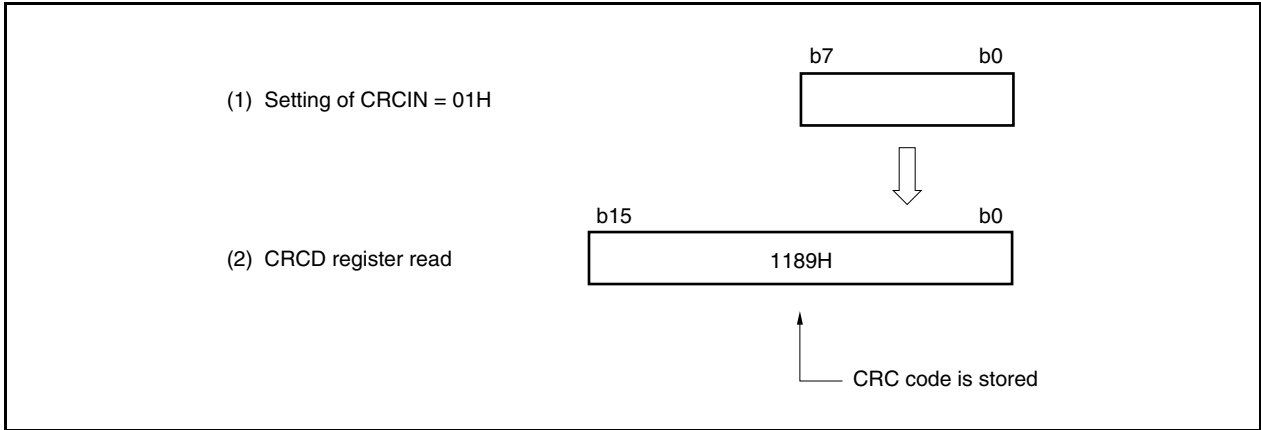

The code when 01H is sent LSB first is (1000 0000). Therefore, the CRC code from generation polynomial  $X^{16} + X^{12} + X^5 + 1$  becomes the remainder when  $(1000\ 0000) X^{16}$  is divided by  $(1\ 0001\ 0000\ 0010\ 0001)$  using the modulo-2 operation formula.

The modulo-2 operation is performed based on the following formula.

- 0 + 0 = 0
- 0 + 1 = 1
- 1 + 0 = 1
- 1 + 1 = 0
- 1 = 1

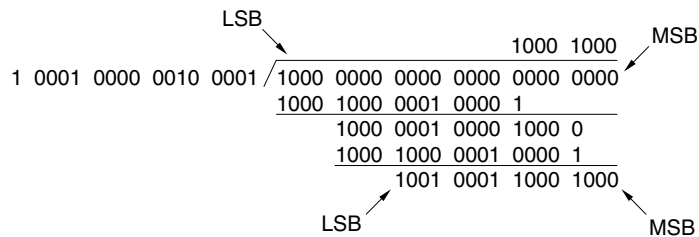

Therefore, the CRC code becomes  $\overbrace{1001}^9 \overbrace{0001}^8 \overbrace{1000}^1 \overbrace{1000}^1$ . Since LSB first is used, this corresponds to 1189H in hexadecimal notation.

## 23.5 Usage Method

How to use the CRC logic circuit is described below.

Figure 23-3. CRC Operation Flow

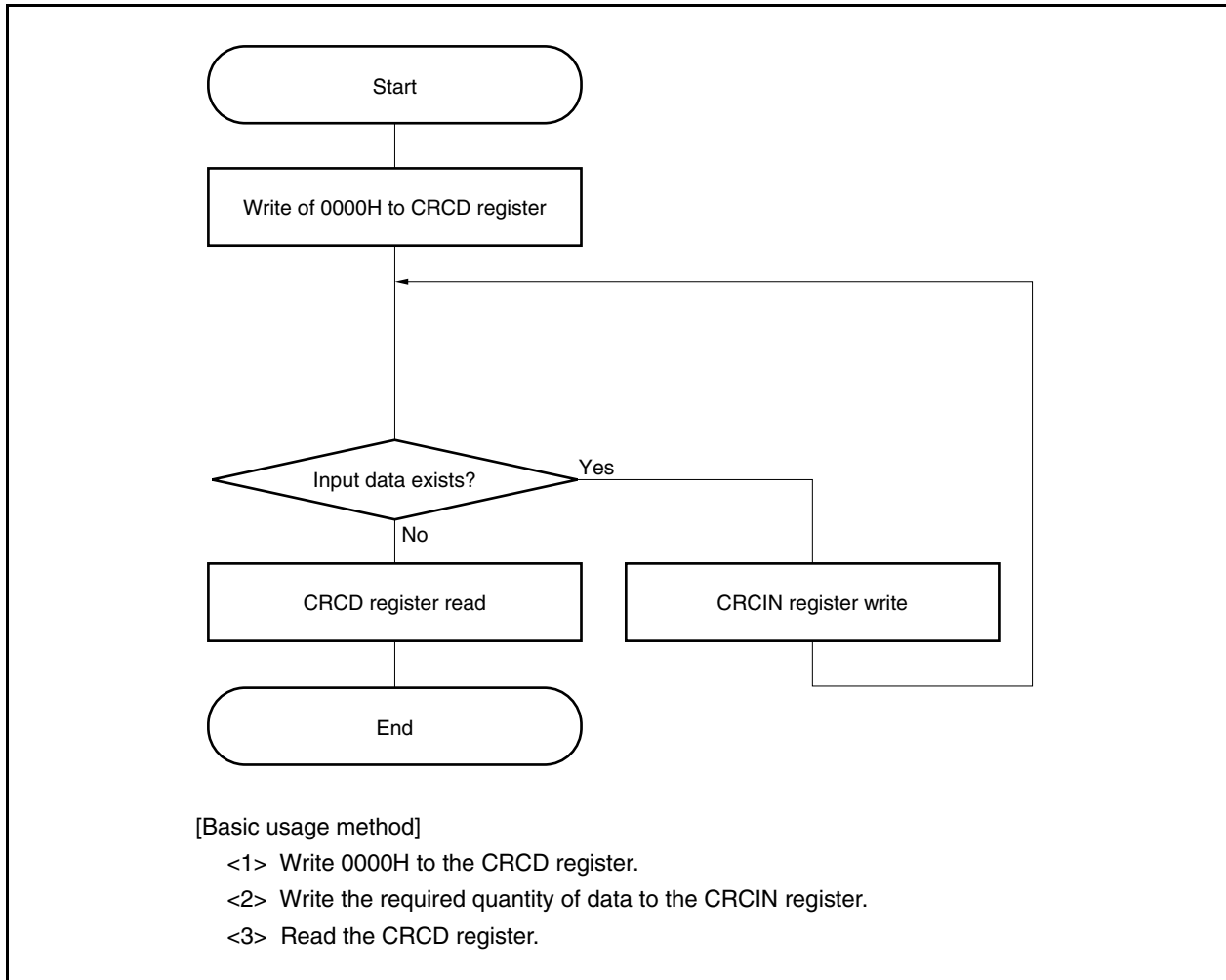

Communication errors can easily be detected if the CRC code is transmitted/received along with transmit/receive data when transmitting/receiving data consisting of several bytes.

The following is an illustration using the transmission of 12345678H (0001 0010 0011 0100 0101 0110 0111 1000B) LSB-first as an example.

**Figure 23-4. CRC Transmission Example**

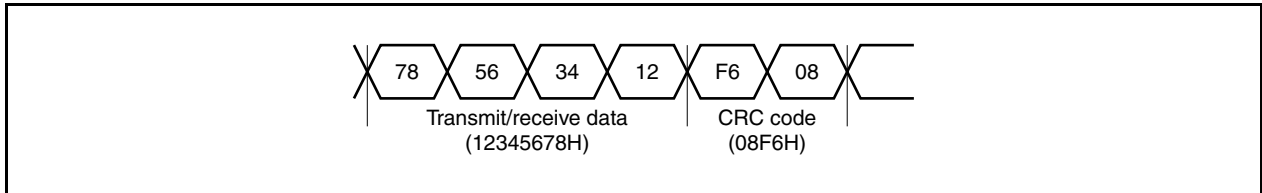

#### Setting procedure on transmitting side

- <1> Write the initial value 0000H to the CRCD register.
- <2> Write the 1 byte of data to be transmitted first to the transmit buffer register. (At this time, also write the same data to the CRCIN register.)
- <3> When transmitting several bytes of data, write the same data to the CRCIN register each time transmit data is written to the transmit buffer register.
- <4> After all the data has been transmitted, write the contents of the CRCD register (CRC code) to the transmit buffer register and transmit them. (Since this is LSB first, transmit the data starting from the lower bytes, then the higher bytes.)

#### Setting procedure on receiving side

- <1> Write the initial value 0000H to the CRCD register.
- <2> When reception of the first 1 byte of data is complete, write that receive data to the CRCIN register.
- <3> If receiving several bytes of data, write the receive data to the CRCIN register upon every reception completion. (In the case of normal reception, when all the receive data has been written to the CRCIN register, the contents of the CRCD register on the receiving side and the contents of the CRCD register on the transmitting side are the same.)
- <4> Next, the CRC code is transmitted from the transmitting side, so write this data to the CRCIN register similarly to receive data.
- <5> When reception of all the data, including the CRC code, has been completed, reception was normal if the contents of the CRCD register are 0000H. If the contents of the CRCD register are other than 0000H, this indicates a communication error, so transmit a resend request to the transmitting side.

## CHAPTER 24 INTERRUPT/EXCEPTION PROCESSING FUNCTION

The V850E/SJ3-H and V850E/SK3-H are provided with a dedicated interrupt controller (INTC) for interrupt <R> servicing and can process a total of 100/104/106/108/110/114 interrupt requests.

An interrupt is an event that occurs independently of program execution, and an exception is an event whose occurrence is dependent on program execution.

The V850E/SJ3-H and V850E/SK3-H can process interrupt request signals from the on-chip peripheral hardware and external sources. Moreover, exception processing can be started by the TRAP instruction (software exception) or by generation of an exception event (i.e. fetching of an illegal opcode) (exception trap).

### 24.1 Features

- Interrupts
  - Non-maskable interrupts: 2 sources
  - <R> • Maskable interrupts: External: 10, Internal: 88/92/94/96/98/102 sources (see **Table 1-1**)
  - 8 levels of programmable priorities (maskable interrupts)
  - Multiple interrupt control according to priority
  - Masks can be specified for each maskable interrupt request.
  - Noise elimination, edge detection, and valid edge specification for external interrupt request signals.
- Exceptions
  - Software exceptions: 32 sources
  - Exception trap: 2 sources (illegal opcode exception and debug trap)

Interrupt/exception sources are listed in Table 24-1.



Table 24-1. Interrupt Source List (1/5)

Type	Classification	Default Priority	Name	Trigger	Generating Unit	Exception Code	Handler Address	Restored PC	Interrupt Control Register
Reset	Interrupt	–	RESET	RESET pin input Reset by internal source	RESET	0000H	00000000H	Undefined	–
Non-maskable	Interrupt	–	NMI	NMI pin valid edge input	Pin	0010H	00000010H	nextPC	–
		–	INTWDT2	WDT2 overflow	WDT2	0020H	00000020H	<b>Note 1</b>	–
Software exception	Exception	–	TRAP0n <sup>Note 2</sup>	TRAP instruction	–	004nH <sup>Note 2</sup>	00000040H	nextPC	–
		–	TRAP1n <sup>Note 2</sup>	TRAP instruction	–	005nH <sup>Note 2</sup>	00000050H	nextPC	–
Exception trap	Exception	–	ILGOP/ DBG0	Illegal opcode/ DBTRAP instruction	–	0060H	00000060H	nextPC	–
Maskable	Interrupt	0	INTLVI	Low voltage detection	POCLVI	0080H	00000080H	nextPC	LVIIIC
		1	INTP0	External interrupt pin input edge detection (INTP0)	Pin	0090H	00000090H	nextPC	PIC0
		2	INTP1	External interrupt pin input edge detection (INTP1)	Pin	00A0H	000000A0H	nextPC	PIC1
		3	INTP2	External interrupt pin input edge detection (INTP2)	Pin	00B0H	000000B0H	nextPC	PIC2
		4	INTP3	External interrupt pin input edge detection (INTP3)	Pin	00C0H	000000C0H	nextPC	PIC3
		5	INTP4	External interrupt pin input edge detection (INTP4)	Pin	00D0H	000000D0H	nextPC	PIC4
		6	INTP5	External interrupt pin input edge detection (INTP5)	Pin	00E0H	000000E0H	nextPC	PIC5
		7	INTP6	External interrupt pin input edge detection (INTP6)	Pin	00F0H	000000F0H	nextPC	PIC6
		8	INTP7	External interrupt pin input edge detection (INTP7)	Pin	0100H	00000100H	nextPC	PIC7
		9	INTTQ0OV	TMQ0 overflow	TMQ0	0110H	00000110H	nextPC	TQ0OVIC
		10	INTTQ0CC0	TMQ0 capture 0/ compare 0 match	TMQ0	0120H	00000120H	nextPC	TQ0CCIC0
		11	INTTQ0CC1	TMQ0 capture 1/ compare 1 match	TMQ0	0130H	00000130H	nextPC	TQ0CCIC1
		12	INTTQ0CC2	TMQ0 capture 2/ compare 2 match	TMQ0	0140H	00000140H	nextPC	TQ0CCIC2
		13	INTTQ0CC3	TMQ0 capture 3/ compare 3 match	TMQ0	0150H	00000150H	nextPC	TQ0CCIC3
		14	INTTP0OV	TMP0 overflow	TMP0	0160H	00000160H	nextPC	TP0OVIC
		15	INTTP0CC0	TMP0 capture 0/ compare 0 match	TMP0	0170H	00000170H	nextPC	TP0CCIC0
		16	INTTP0CC1	TMP0 capture 1/ compare 1 match	TMP0	0180H	00000180H	nextPC	TP0CCIC1
17	INTTP1OV	TMP1 overflow	TMP1	0190H	00000190H	nextPC	TP1OVIC		

**Notes** 1. For the restoring in the case of INTWDT2, see 24.2.2 (2) INTWDT2 signal.

2. n = 0 to FH

Table 24-1. Interrupt Source List (2/5)

Type	Classification	Default Priority	Name	Trigger	Generating Unit	Exception Code	Handler Address	Restored PC	Interrupt Control Register
Maskable	Interrupt	18	INTTP1CC0	TMP1 capture 0/ compare 0 match	TMP1	01A0H	000001A0H	nextPC	TP1CCIC0
		19	INTTP1CC1	TMP1 capture 1/ compare 1 match	TMP1	01B0H	000001B0H	nextPC	TP1CCIC1
		20	INTTP2OV	TMP2 overflow	TMP2	01C0H	000001C0H	nextPC	TP2OVIC
		21	INTTP2CC0	TMP2 capture 0/ compare 0 match	TMP2	01D0H	000001D0H	nextPC	TP2CCIC0
		22	INTTP2CC1	TMP2 capture 1/ compare 1 match	TMP2	01E0H	000001E0H	nextPC	TP2CCIC1
		23	INTTP3OV	TMP3 overflow	TMP3	01F0H	000001F0H	nextPC	TP3OVIC
		24	INTTP3CC0	TMP3 capture 0/ compare 0 match	TMP3	0200H	00000200H	nextPC	TP3CCIC0
		25	INTTP3CC1	TMP3 capture 1/ compare 1 match	TMP3	0210H	00000210H	nextPC	TP3CCIC1
		26	INTTP4OV	TMP4 overflow	TMP4	0220H	00000220H	nextPC	TP4OVIC
		27	INTTP4CC0	TMP4 capture 0/ compare 0 match	TMP4	0230H	00000230H	nextPC	TP4CCIC0
		28	INTTP4CC1	TMP4 capture 1/ compare 1 match	TMP4	0240H	00000240H	nextPC	TP4CCIC1
		29	INTTP5OV	TMP5 overflow	TMP5	0250H	00000250H	nextPC	TP5OVIC
		30	INTTP5CC0	TMP5 capture 0/ compare 0 match	TMP5	0260H	00000260H	nextPC	TP5CCIC0
		31	INTTP5CC1	TMP5 capture 1/ compare 1 match	TMP5	0270H	00000270H	nextPC	TP5CCIC1
		32	INTTM0EQ0	TMM0 compare match	TMM0	0280H	00000280H	nextPC	TM0EQIC0
		33	INTCB0R/ INTIIC1	CSIB0 reception completion/CSIB0 reception error/IIC1 transfer completion	CSIB0/ I <sup>2</sup> C01	0290H	00000290H	nextPC	CB0RIC/ IIC1C1
		34	INTCB0T	CSIB0 consecutive transmission write enable	CSIB0	02A0H	000002A0H	nextPC	CB0TIC
		35	INTCB1R	CSIB1 reception completion/CSIB1 reception error	CSIB1	02B0H	000002B0H	nextPC	CB1RIC
		36	INTCB1T	CSIB1 consecutive transmission write enable	CSIB1	02C0H	000002C0H	nextPC	CB1TIC
		37	INTCB2R	CSIB2 reception completion/CSIB2 reception error	CSIB2	02D0H	000002D0H	nextPC	CB2RIC
38	INTCB2T	CSIB2 consecutive transmission write enable	CSIB2	02E0H	000002E0H	nextPC	CB2TIC		
39	INTCB3R	CSIB3 reception completion/CSIB3 reception error	CSIB3	02F0H	000002F0H	nextPC	CB3RIC		
40	INTCB3T	CSIB3 consecutive transmission write enable	CSIB3	0300H	00000300H	nextPC	CB3TIC		

Table 24-1. Interrupt Source List (3/5)

Type	Classification	Default Priority	Name	Trigger	Generating Unit	Exception Code	Handler Address	Restored PC	Interrupt Control Register
Maskable	Interrupt	41	INTUA0R/ INTCB4R	UARTA0 reception completion/UARTA0 reception error/CSIB4 reception completion/CSIB4 reception error	UARTA0/ CSIB4	0310H	00000310H	nextPC	UA0RIC/ CB4RIC
		42	INTUA0T/ INTCB4T	UARTA0 consecutive transmission enable/CSIB4 consecutive transmission write enable	UARTA0/ CSIB4	0320H	00000320H	nextPC	UA0TIC/ CB4TIC
		43	INTUA1R	UARTA1 reception completion/UARTA1 reception error	UARTA1	0330H	00000330H	nextPC	UA1RIC
		44	INTUA1T	UARTA1 consecutive transmission enable	UARTA1	0340H	00000340H	nextPC	UA1TIC
		45	INTUA2R	UARTA2 reception completion/UARTA2 reception error	UARTA2	0350H	00000350H	nextPC	UA2RIC
		46	INTUA2T	UARTA2 consecutive transmission enable	UARTA2	0360H	00000360H	nextPC	UA2TIC
		47	INTAD	A/D conversion completion	A/D	0370H	00000370H	nextPC	ADIC
		48	INTDMA0	DMA0 transfer completion	DMA	0380H	00000380H	nextPC	DMAIC0
		49	INTDMA1	DMA1 transfer completion	DMA	0390H	00000390H	nextPC	DMAIC1
		50	INTDMA2	DMA2 transfer completion	DMA	03A0H	000003A0H	nextPC	DMAIC2
		51	INTDMA3	DMA3 transfer completion	DMA	03B0H	000003B0H	nextPC	DMAIC3
		52	INTKR	Key return interrupt	KR	03C0H	000003C0H	nextPC	KRIC
		53	INTWTI	Watch timer interval	WT	03D0H	000003D0H	nextPC	WTIC
		54	INTWT	Watch timer reference time	WT	03E0H	000003E0H	nextPC	WTIC
		55	INTC0ERR <sup>Note 1</sup>	AFCAN0 error	AFCAN0	03F0H	000003F0H	nextPC	ERRIC0
		56	INTC0WUP <sup>Note 1</sup>	AFCAN0 wakeup	AFCAN0	0400H	00000400H	nextPC	WUPIC0
		57	INTC0REC <sup>Note 1</sup>	AFCAN0 reception	AFCAN0	0410H	00000410H	nextPC	RECIC0
		58	INTC0TRX <sup>Note 2</sup>	AFCAN0 transmission	AFCAN0	0420H	00000420H	nextPC	TRXIC0
		59	INTC1ERR <sup>Note 2</sup>	AFCAN1 error	AFCAN1	0430H	00000430H	nextPC	ERRIC1
		60	INTC1WUP <sup>Note 2</sup>	AFCAN1 wakeup	AFCAN1	0440H	00000440H	nextPC	WUPIC1
		61	INTC1REC <sup>Note 2</sup>	AFCAN1 reception	AFCAN1	0450H	00000450H	nextPC	RECIC1
		62	INTC1TRX <sup>Note 2</sup>	AFCAN1 transmission	AFCAN1	0460H	00000460H	nextPC	TRXIC1
		63	INTP8	External interrupt pin input edge detection (INTP8)	Pin	0470H	00000470H	nextPC	PIC8
		64	INTTP6OV	TMP6 overflow	TMP6	0480H	00000480H	nextPC	TP6OVIC
		65	INTTP6CC0	TMP6 capture 0/ compare 0 match	TMP6	0490H	00000490H	nextPC	TP6CCIC0
		66	INTTP6CC1	TMP6 capture 1/ compare 1 match	TMP6	04A0H	000004A0H	nextPC	TP6CCIC1
		67	INTTP7OV	TMP7 overflow	TMP7	04B0H	000004B0H	nextPC	TP7OVIC
		68	INTTP7CC0	TMP7 capture 0/ compare 0 match	TMP7	04C0H	000004C0H	nextPC	TP7CCIC0
		69	INTTP7CC1	TMP7 capture 1/ compare 1 match	TMP7	04D0H	000004D0H	nextPC	TP7CCIC1

- Notes 1. CAN controller version only  
 2. CAN controller (2-channel) version only



Table 24-1. Interrupt Source List (5/5)

Type	Classification	Default Priority	Name	Trigger	Generating Unit	Exception Code	Handler Address	Restored PC	Interrupt Control Register
Maskable	Interrupt	105	INTUB1TITO	UARTB1 reception timeout	UARTB1	0710H	00000710H	nextPC	UB1TITOIC
		106	INTUA5R	UARTA5 reception completion/UARTA5 reception error	UARTA5	0720H	00000720H	nextPC	UA5RIC
		107	INTUA5T	UARTA5 consecutive transmission enable	UARTA5	0730H	00000730H	nextPC	UA5TIC
		108	INTERR	IEBus error	IEBus	0740H	00000740H	nextPC	ERRIC
		109	INTSTA	IEBus status	IEBus	0750H	00000750H	nextPC	STAIC
		110	INTIE1	IEBus data interrupt	IEBus	0760H	00000760H	nextPC	IEIC1
		111	INTIE2	IEBus error/IEBus status	IEBus	0770H	00000770H	nextPC	IEIC2
		112	INTRTC0	RTC constant cycle signal	RTC	0780H	00000780H	nextPC	RTC0IC
		113	INTRTC1	RTC alarm match	RTC	0790H	00000790H	nextPC	RTC1IC
		114	INTRTC2	RTC interval signal	RTC	07A0H	000007A0H	nextPC	RTC2IC

**Remarks 1.** Default Priority: The priority order when two or more maskable interrupt requests occur at the same time. The highest priority is 0.

The priority order of non-maskable interrupt is INTWDT2 > NMI.

Restored PC: The value of the program counter (PC) saved to EIPC, FEPC, or DBPC when interrupt servicing is started. Note, however, that the restored PC when a non-maskable or maskable interrupt is acknowledged while one of the following instructions is being executed does not become the nextPC (if an interrupt is acknowledged during interrupt execution, execution stops, and then resumes after the interrupt servicing has finished).

- Load instructions (SLD.B, SLD.BU, SLD.H, SLD.HU, SLD.W)
- Division instructions (DIV, DIVH, DIVU, DIVHU)
- PREPARE, DISPOSE instructions (only if an interrupt is generated before the stack pointer is updated)

nextPC: The PC value that starts the processing following interrupt/exception processing.

2. The execution address of the illegal instruction when an illegal opcode exception occurs is calculated by (Restored PC – 4).

## 24.2 Non-Maskable Interrupts

A non-maskable interrupt request signal is acknowledged unconditionally, even when interrupts are in the interrupt disabled (DI) status. An NMI is not subject to priority control and takes precedence over all the other interrupt request signals.

This product has the following two non-maskable interrupt request signals.

- NMI pin input (NMI)
- Non-maskable interrupt request signal generated by overflow of watchdog timer (INTWDT2)

The valid edge of the NMI pin can be selected from four types: “rising edge”, “falling edge”, “both edges”, and “no edge detection”.

The non-maskable interrupt request signal generated by overflow of the watchdog timer 2 (INTWDT2) functions when the WDTM2.WDM21 and WDTM2.WDM20 bits are set to “01”.

If two or more non-maskable interrupt request signals occur at the same time, the interrupt with the higher priority is serviced, as follows (the interrupt request signal with the lower priority is ignored).

INTWDT2 > NMI

If a new NMI or INTWDT2 request signal is issued while a NMI is being serviced, it is serviced as follows.

### (1) If new NMI request signal is issued while NMI is being serviced

The new NMI request signal is held pending, regardless of the value of the PSW.NP bit. The pending NMI request signal is acknowledged after the NMI currently under execution has been serviced (after the RETI instruction has been executed).

### (2) If INTWDT2 request signal is issued while NMI is being serviced

The INTWDT2 request signal is held pending if the NP bit remains set (1) while the NMI is being serviced. The pending INTWDT2 request signal is acknowledged after the NMI currently under execution has been serviced (after the RETI instruction has been executed).

If the NP bit is cleared (0) while the NMI is being serviced, the newly generated INTWDT2 request signal is executed (the NMI servicing is stopped).

**Caution** For the non-maskable interrupt servicing executed by the non-maskable interrupt request signal (INTWDT2), see 24.2.2 (2) INTWDT2 signal.

Figure 24-1. Non-Maskable Interrupt Request Signal Acknowledgment Operation (1/2)

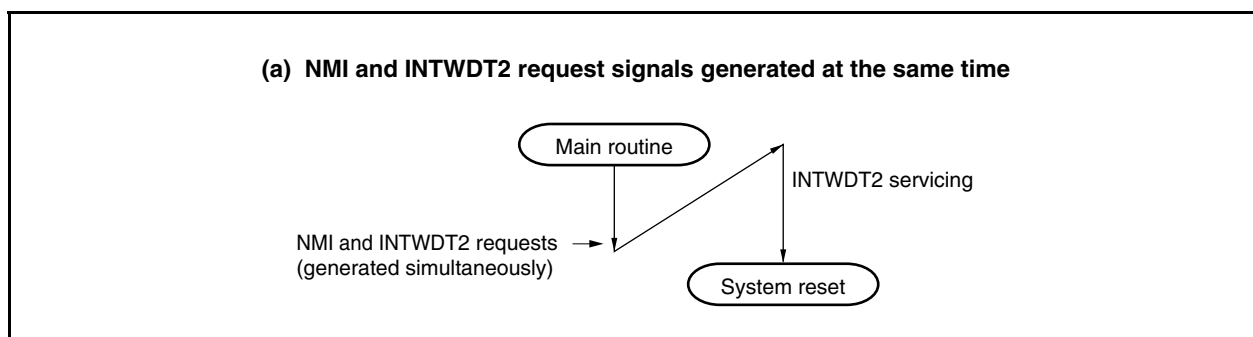
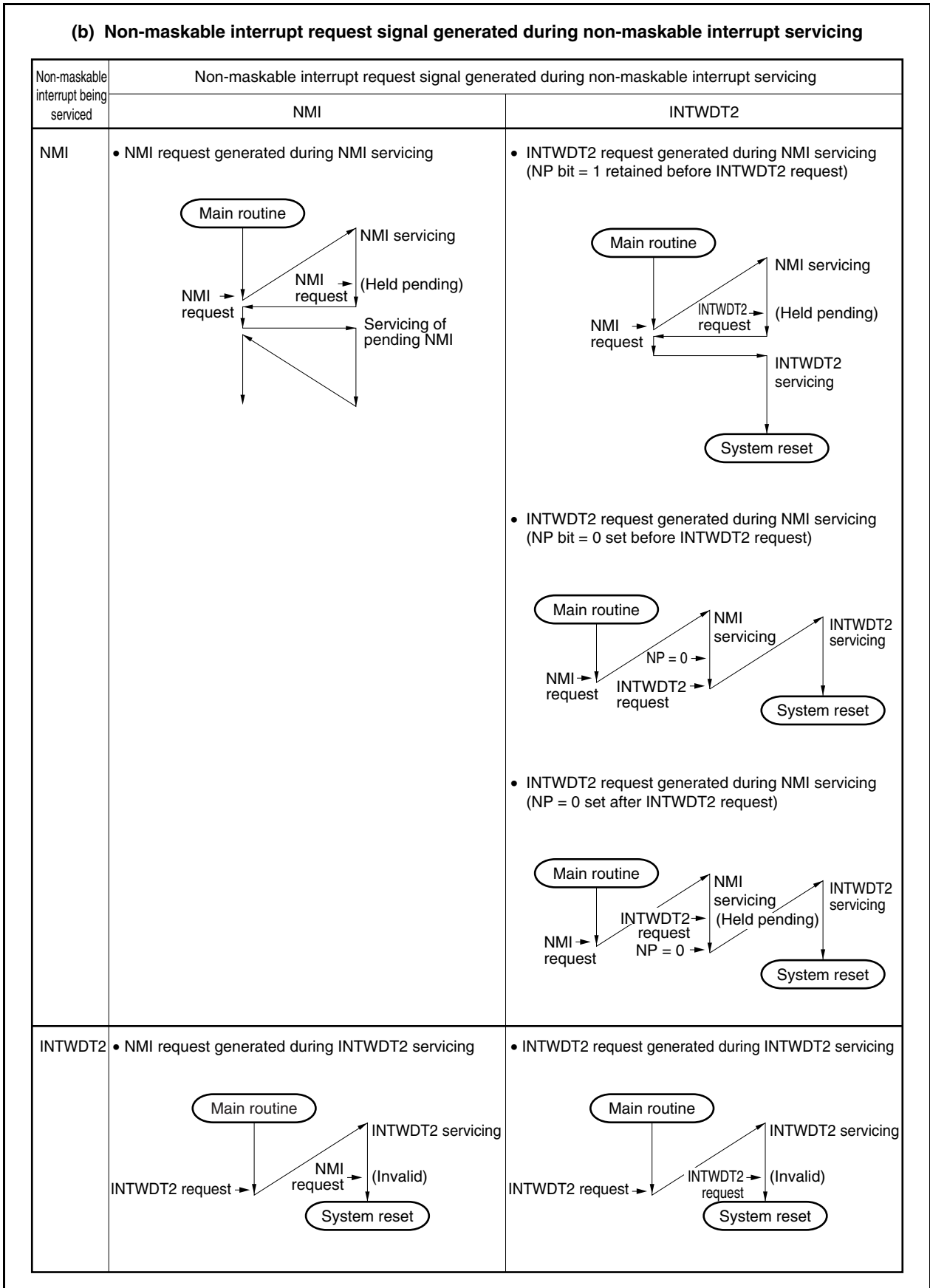

Figure 24-1. Non-Maskable Interrupt Request Signal Acknowledgment Operation (2/2)



**24.2.1 Operation**

If a non-maskable interrupt request signal is generated, the CPU performs the following processing, and transfers control to the handler routine.

- <1> Saves the restored PC to FEPC.
- <2> Saves the current PSW to FEPSW.
- <3> Writes exception code (0010H, 0020H) to the higher halfword (FECC) of ECR.
- <4> Sets the PSW.NP and PSW.ID bits to 1 and clears the PSW.EP bit to 0.
- <5> Sets the handler address (00000010H, 00000020H) corresponding to the non-maskable interrupt to the PC, and transfers control.

The servicing configuration of a non-maskable interrupt is shown in Figure 24-2.

**Figure 24-2. Servicing Configuration of Non-Maskable Interrupt**

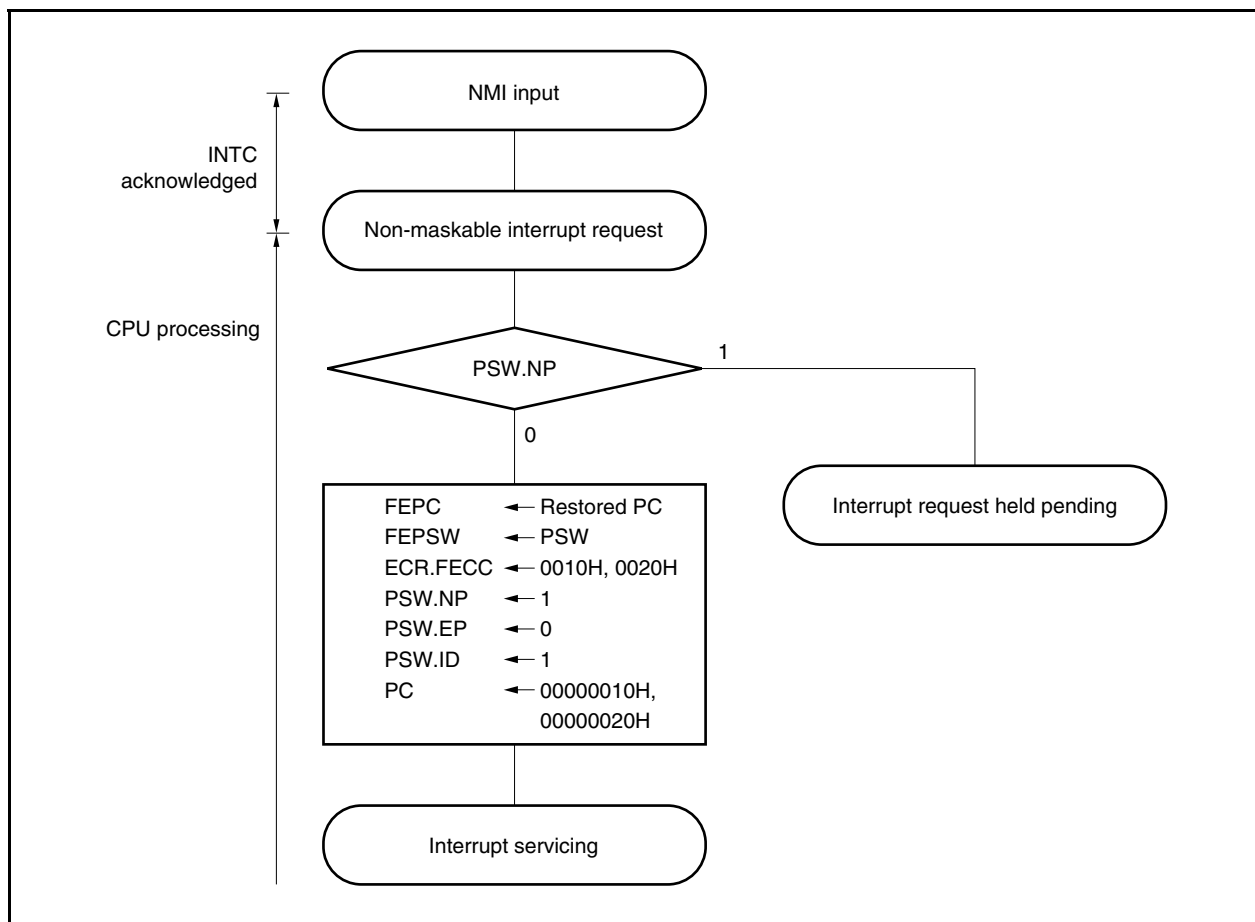



## 24.2.2 Restore

## (1) From NMI pin input

Execution is restored from the NMI servicing by the RETI instruction.

When the RETI instruction is executed, the CPU performs the following processing, and transfers control to the address of the restored PC.

- <1> Loads the restored PC and PSW from FEPC and FEPSW, respectively, because the PSW.EP bit is 0 and the PSW.NP bit is 1.
- <2> Transfers control back to the address of the restored PC and PSW.

Figure 24-3 illustrates how the RETI instruction is processed.

Figure 24-3. RETI Instruction Processing

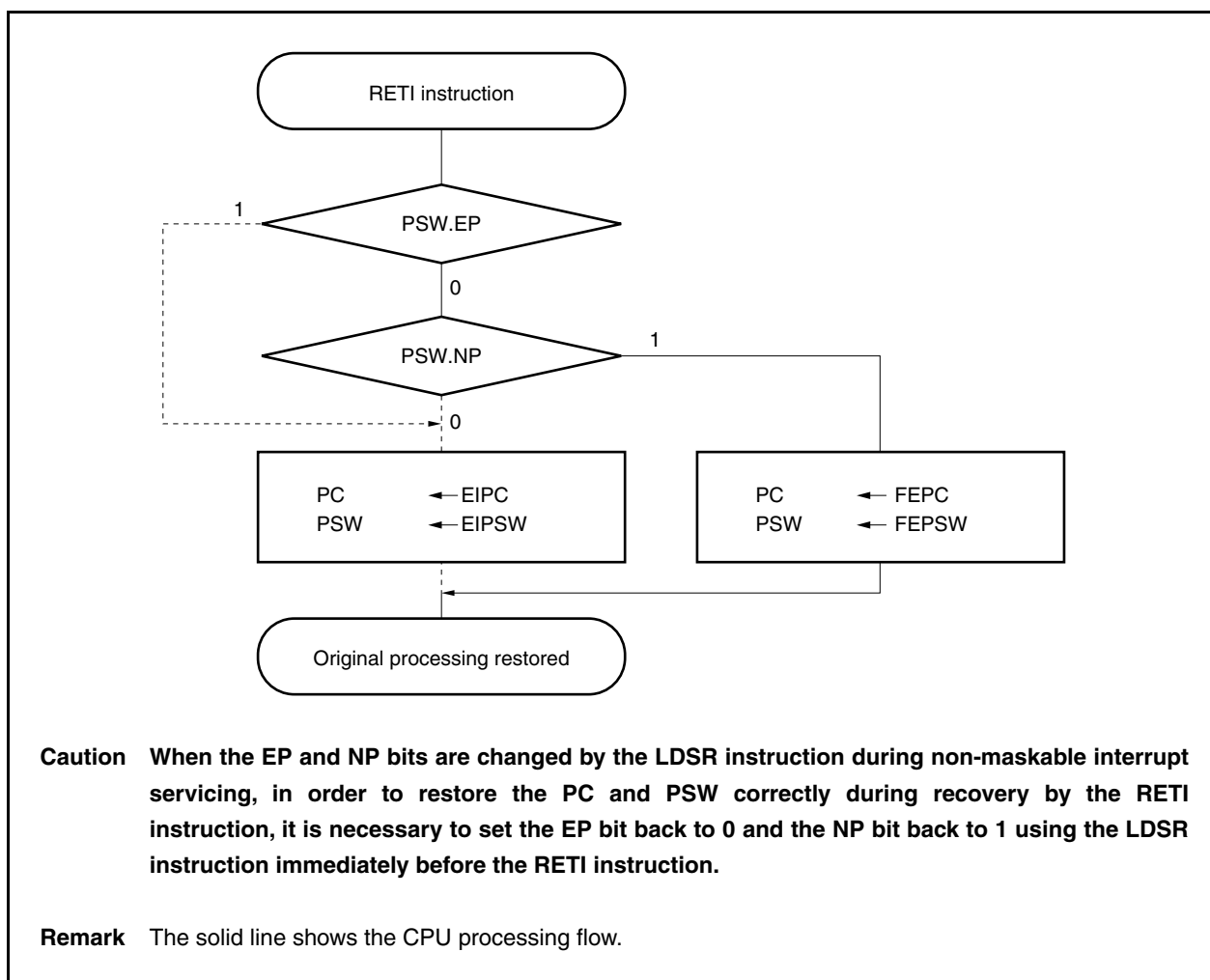

(2) From INTWDT2 signal

Restoring from non-maskable interrupt servicing executed by the non-maskable interrupt request (INTWDT2) by using the RETI instruction is disabled. Execute the following software reset processing.

Figure 24-4. Software Reset Processing

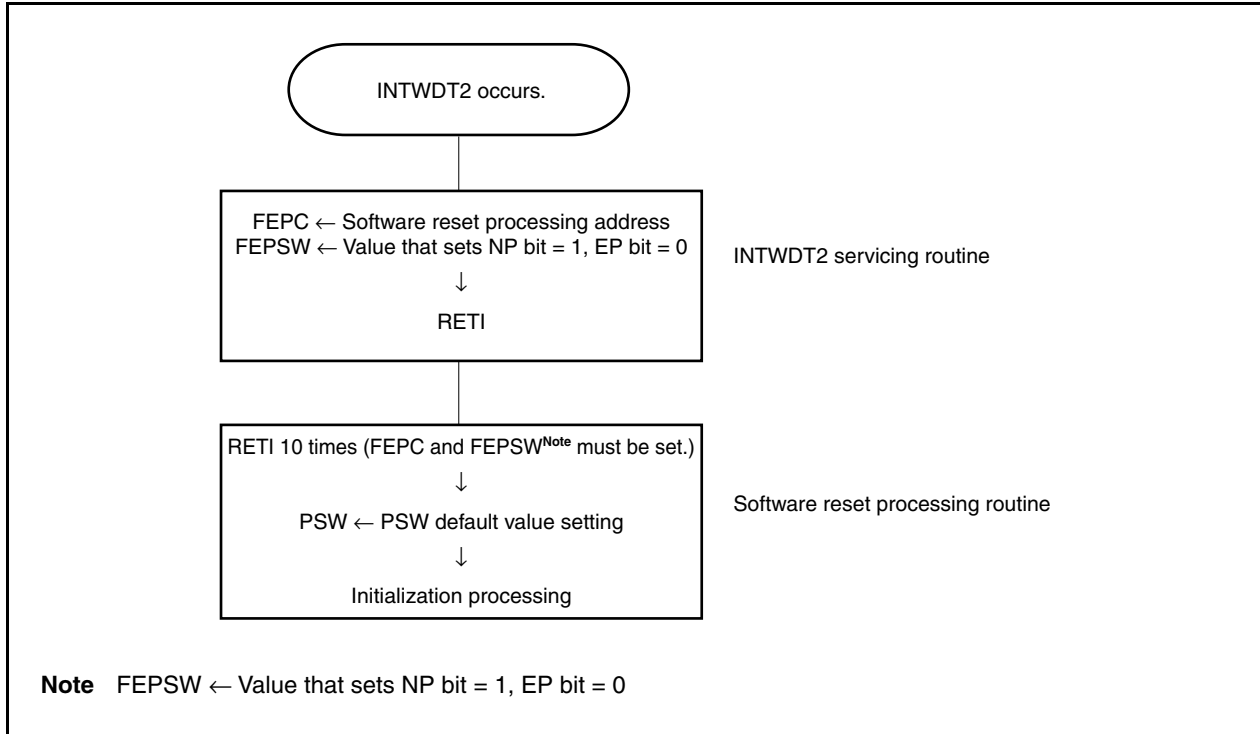

24.2.3 NP flag

The NP flag is a status flag that indicates that non-maskable interrupt servicing is under execution.

This flag is set when a non-maskable interrupt request signal has been acknowledged, and masks non-maskable interrupt requests to prohibit multiple interrupts from being acknowledged.

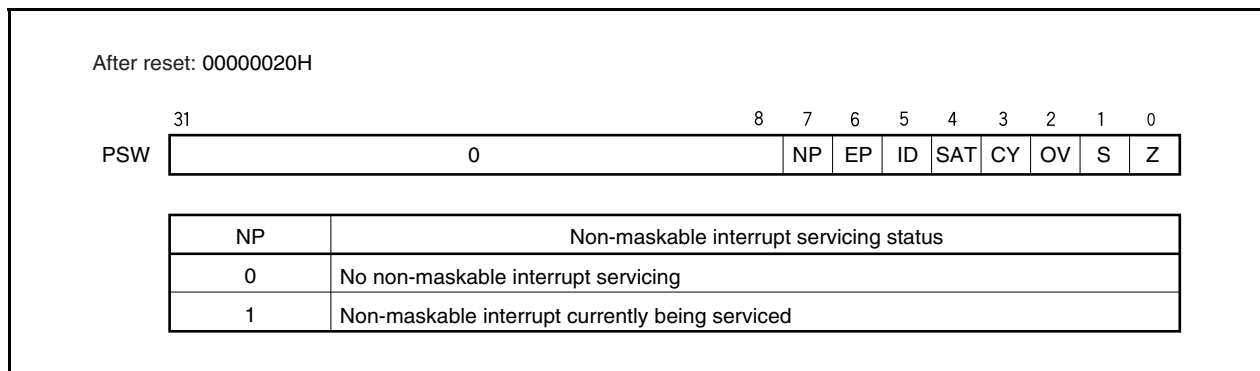

## 24.3 Maskable Interrupts

&lt;R&gt;

Maskable interrupt request signals can be masked by interrupt control registers. The V850E/SJ3-H and V850E/SK3-H have 98/102/104/106/108/112 maskable interrupt sources.

If two or more maskable interrupt request signals are generated at the same time, they are acknowledged according to the default priority. In addition to the default priority, eight levels of priorities can be specified by using the interrupt control registers (programmable priority control).

When an interrupt request signal has been acknowledged, the acknowledgment of other maskable interrupt request signals is disabled and the interrupt disabled (DI) status is set.

When the EI instruction is executed in an interrupt servicing routine, the interrupt enabled (EI) status is set, which enables servicing of interrupts having a higher priority than the interrupt request signal in progress (specified by the interrupt control register). Note that only interrupts with a higher priority will have this capability; interrupts with the same priority level cannot be nested.

To enable multiple interrupts, however, save EIPC and EIPSW to memory or general-purpose registers before executing the EI instruction, and execute the DI instruction before the RETI instruction to restore the original values of EIPC and EIPSW.

### 24.3.1 Operation

If a maskable interrupt occurs, the CPU performs the following processing, and transfers control to a handler routine.

- <1> Saves the restored PC to EIPC.
- <2> Saves the current PSW to EIPSW.
- <3> Writes an exception code to the lower halfword of ECR (EICC).
- <4> Sets the PSW.ID bit to 1 and clears the PSW.EP bit to 0.
- <5> Sets the handler address corresponding to each interrupt to the PC, and transfers control.

The maskable interrupt request signal masked by INTC and the maskable interrupt request signal generated while another interrupt is being serviced (while the PSW.NP bit = 1 or the PSW.ID bit = 1) are held pending inside INTC. In this case, servicing a new maskable interrupt is started in accordance with the priority of the pending maskable interrupt request signal if either the maskable interrupt is unmasked or the NP and ID bits are cleared to 0 by using the RETI or LDSR instruction.

How maskable interrupts are serviced is illustrated below.

Figure 24-5. Maskable Interrupt Servicing

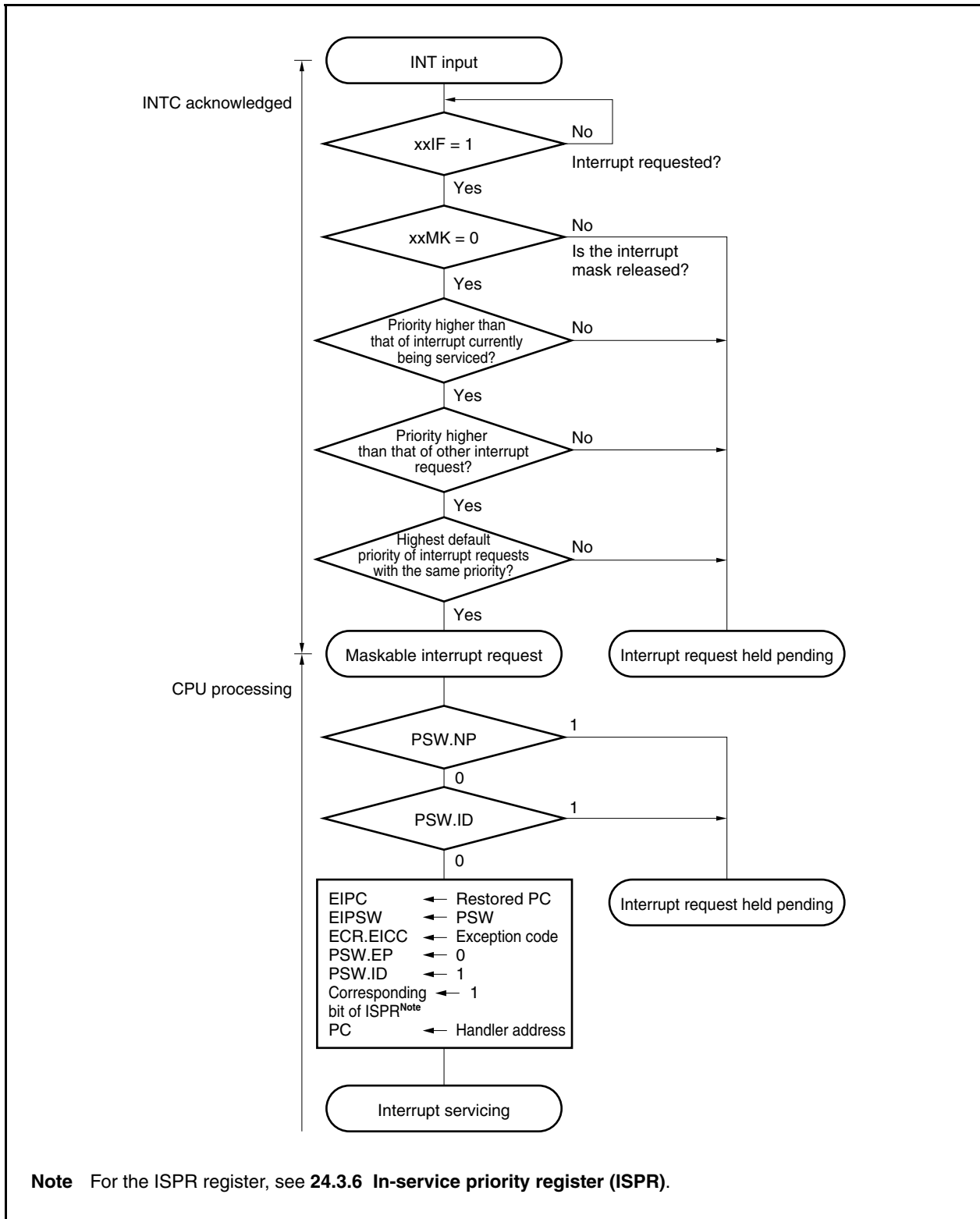

### 24.3.2 Restore

Recovery from maskable interrupt servicing is carried out by the RETI instruction.

When the RETI instruction is executed, the CPU performs the following steps, and transfers control to the address of the restored PC.

- <1> Loads the restored PC and PSW from EIPC and EIPSW because the PSW.EP bit is 0 and the PSW.NP bit is 0.
- <2> Transfers control to the address of the restored PC and PSW.

Figure 24-6 illustrates the processing of the RETI instruction.

**Figure 24-6. RETI Instruction Processing**

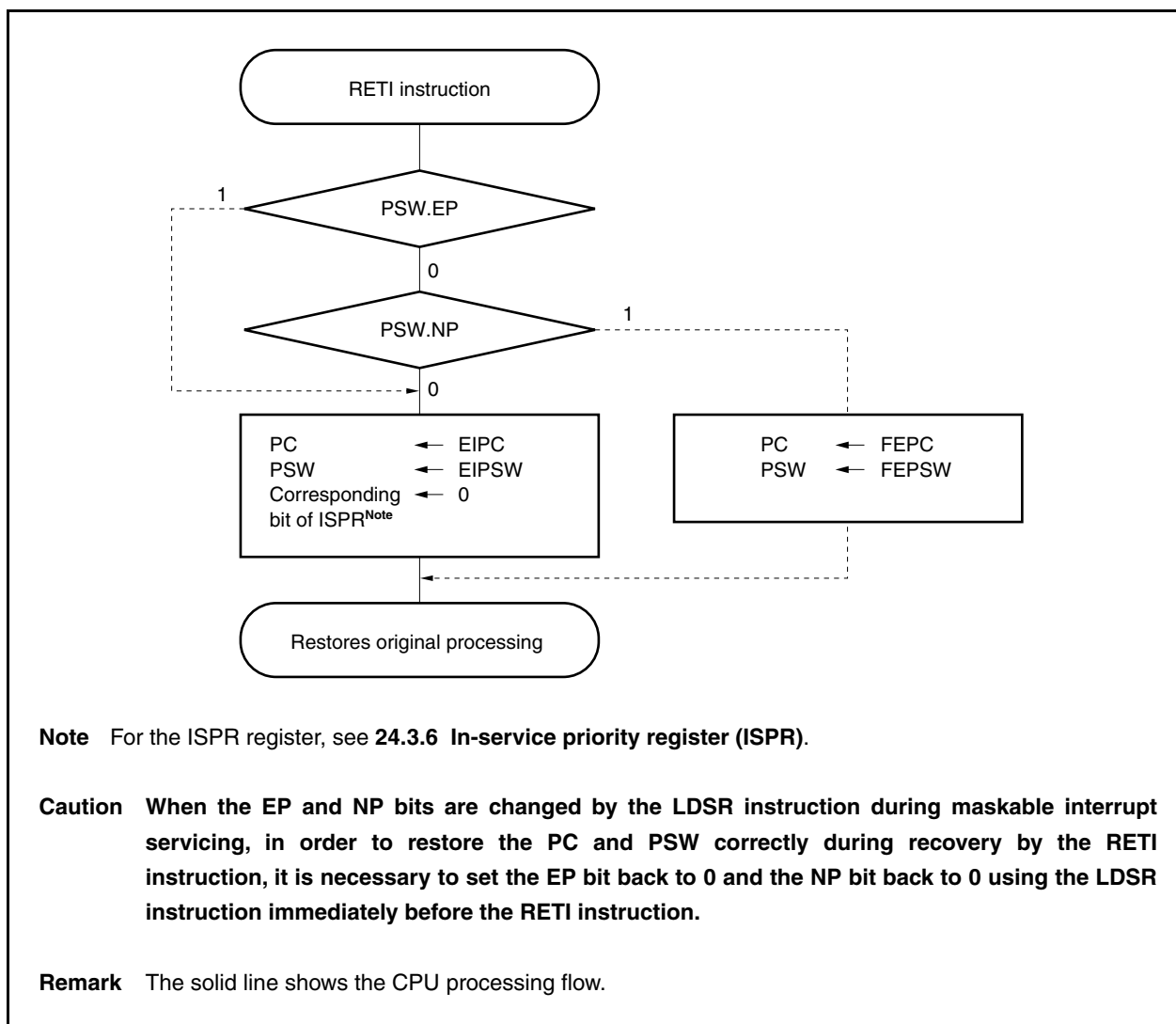

### 24.3.3 Priorities of maskable interrupts

The INTC performs multiple interrupt servicing in which an interrupt is acknowledged while another interrupt is being serviced. Multiple interrupts can be controlled by priority levels.

There are two types of priority level control: control based on the default priority levels, and control based on the programmable priority levels that are specified by the interrupt priority level specification bit (xxPRn) of the interrupt control register (xxICn). When two or more interrupts having the same priority level specified by the xxPRn bit are generated at the same time, interrupt request signals are serviced in order depending on the priority level allocated to each interrupt request type (default priority level) beforehand. For more information, see **Table 24-1 Interrupt/Exception Source List**. The programmable priority control customizes interrupt request signals into eight levels by setting the priority level specification flag.

Note that when an interrupt request signal is acknowledged, the PSW.ID flag is automatically set to 1. Therefore, when multiple interrupts are to be used, clear the ID flag to 0 beforehand (for example, by placing the EI instruction in the interrupt servicing program) to set the interrupt enable mode.

**Remark** xx: Identification name of each peripheral unit (see **Table 24-2 Interrupt Control Register (xxICn)**)  
n: Peripheral unit number (see **Table 24-2 Interrupt Control Register (xxICn)**).

**Figure 24-7. Example of Processing in Which Another Interrupt Request Signal Is Issued While an Interrupt Is Being Serviced (1/2)**

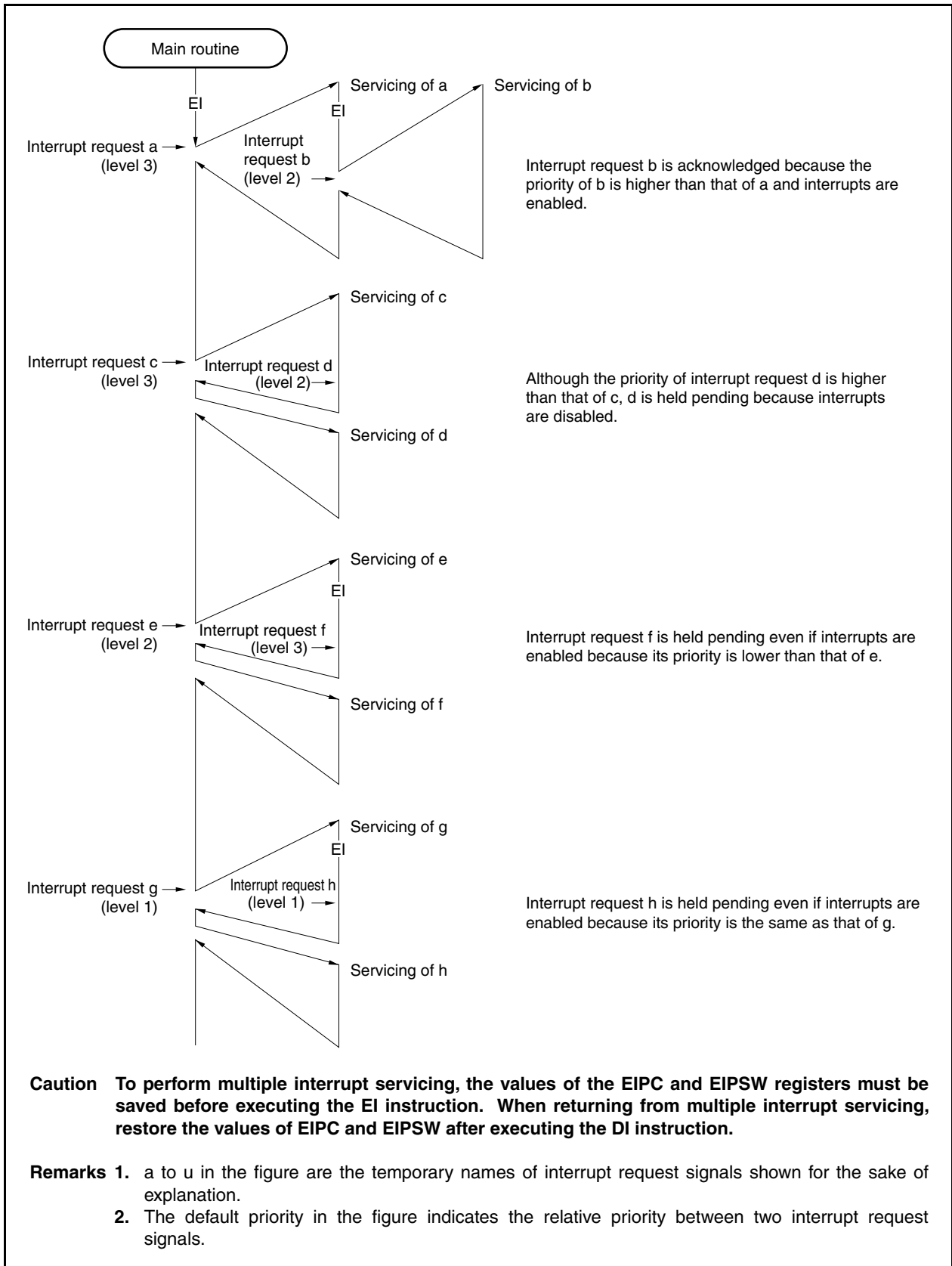

**Figure 24-7. Example of Processing in Which Another Interrupt Request Signal Is Issued While an Interrupt Is Being Serviced (2/2)**

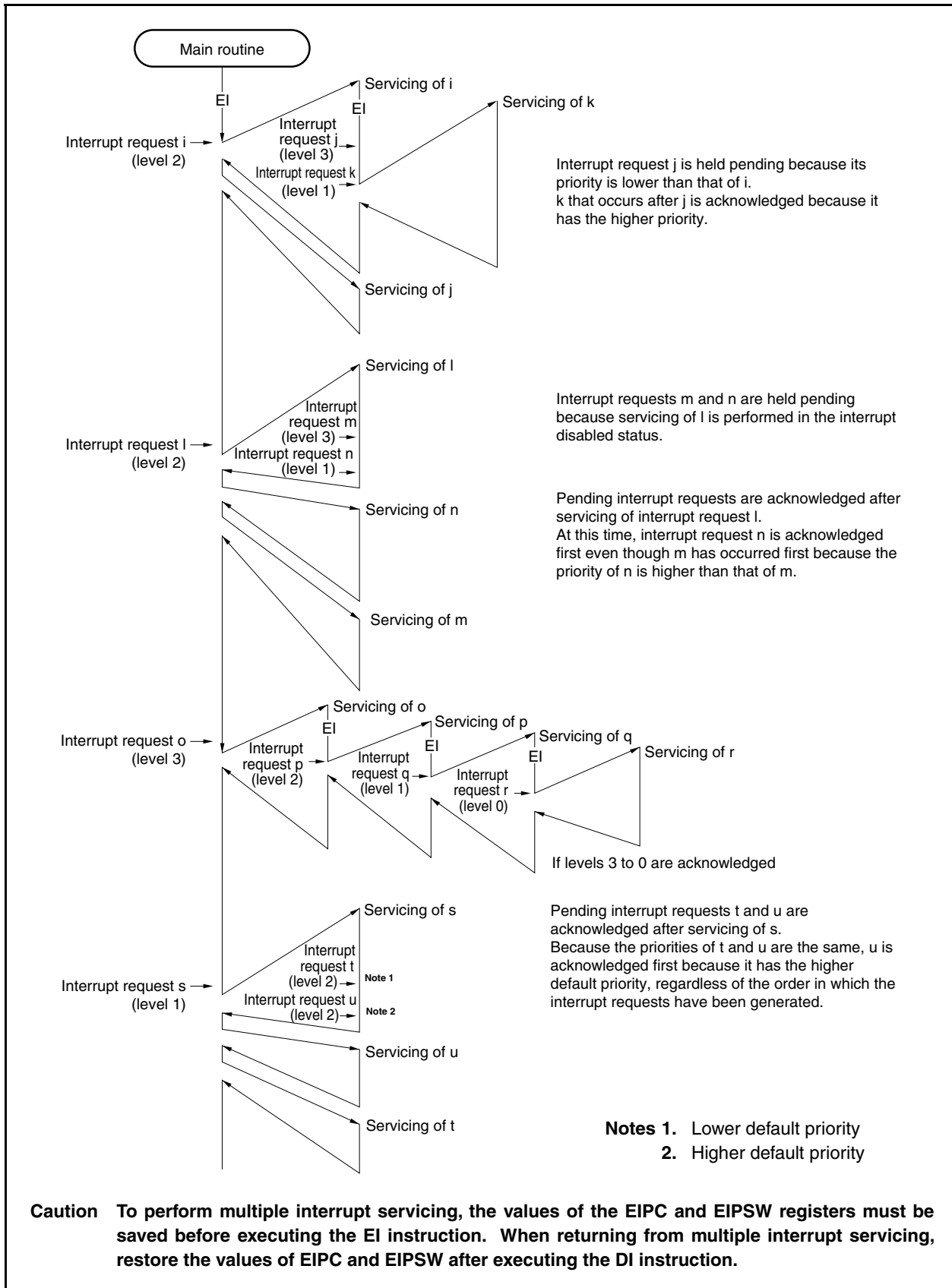
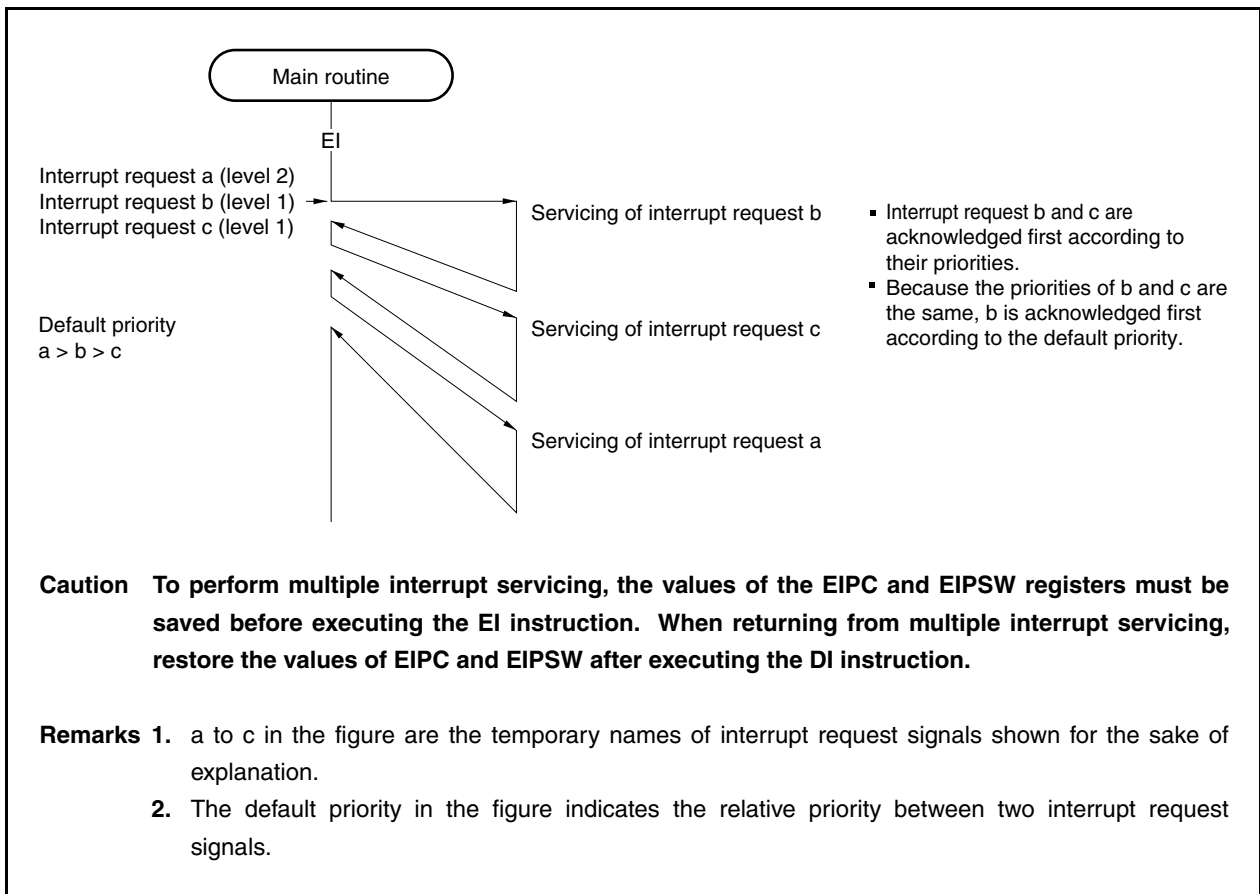



Figure 24-8. Example of Servicing Interrupt Request Signals Simultaneously Generated



**24.3.4 Interrupt control register (xxICn)**

The xxICn register is assigned to each interrupt request signal (maskable interrupt) and sets the control conditions for each maskable interrupt request.

This register can be read or written in 8-bit or 1-bit units.

Reset sets this register to 47H.

- Cautions 1. Disable interrupts (DI) or mask the interrupt to read the xxICn.xxIFn bit. If the xxIFn bit is read while interrupts are enabled (EI) or while the interrupt is unmasked, the correct value may not be read when acknowledging an interrupt and reading the bit conflict.**
- 2. When manipulating the xxICn.xxMKn bit with the state where an interrupt request can be generated (including an interrupt disable (DI) state), be sure to manipulate with a bit manipulation instruction or by using the IMRm.xxMKn and IMR7L.xxMKn bits (m = 0 to 6).**

After reset: 47H    R/W    Address: FFFFF110H to FFFFF1F4H

	<7>	<6>	5	4	3	2	1	0
xxICn	xxIFn	xxMKn	0	0	0	xxPRn2	xxPRn1	xxPRn0

xxIFn	Interrupt request flag <sup>Note</sup>
0	Interrupt request not issued
1	Interrupt request issued

xxMKn	Interrupt mask flag
0	Interrupt servicing enabled
1	Interrupt servicing disabled (pending)

xxPRn2	xxPRn1	xxPRn0	Interrupt priority specification bit
0	0	0	Specifies level 0 (highest).
0	0	1	Specifies level 1.
0	1	0	Specifies level 2.
0	1	1	Specifies level 3.
1	0	0	Specifies level 4.
1	0	1	Specifies level 5.
1	1	0	Specifies level 6.
1	1	1	Specifies level 7 (lowest).

**Note** The flag xxIFn is reset automatically by the hardware if an interrupt request signal is acknowledged.

**Caution** Be sure to set bits 3 to 5 to “0”.

**Remark** xx: Identification name of each peripheral unit (see **Table 24-2 Interrupt Control Register (xxICn)**)  
n: Peripheral unit number (see **Table 24-2 Interrupt Control Register (xxICn)**)

The addresses and bits of the interrupt control registers are as follows.

Table 24-2. Interrupt Control Register (xxICn) (1/3)

Address	Register	Bit							
		<7>	<6>	5	4	3	2	1	0
FFFFF110H	LVVIC	LVVIF	LVVIMK	0	0	0	LVVPR2	LVVPR1	LVVPR0
FFFFF112H	PIC0	PIF0	PMK0	0	0	0	PPR02	PPR01	PPR00
FFFFF114H	PIC1	PIF1	PMK1	0	0	0	PPR12	PPR11	PPR10
FFFFF116H	PIC2	PIF2	PMK2	0	0	0	PPR22	PPR21	PPR20
FFFFF118H	PIC3	PIF3	PMK3	0	0	0	PPR32	PPR31	PPR30
FFFFF11AH	PIC4	PIF4	PMK4	0	0	0	PPR42	PPR41	PPR40
FFFFF11CH	PIC5	PIF5	PMK5	0	0	0	PPR52	PPR51	PPR50
FFFFF11EH	PIC6	PIF6	PMK6	0	0	0	PPR62	PPR61	PPR60
FFFFF120H	PIC7	PIF7	PMK7	0	0	0	PPR72	PPR71	PPR70
FFFFF122H	TQ0OVIC	TQ0OVIF	TQ0OVMK	0	0	0	TQ0OVPR2	TQ0OVPR1	TQ0OVPR0
FFFFF124H	TQ0CCIC0	TQ0CCIF0	TQ0CCMK0	0	0	0	TQ0CCPR02	TQ0CCPR01	TQ0CCPR00
FFFFF126H	TQ0CCIC1	TQ0CCIF1	TQ0CCMK1	0	0	0	TQ0CCPR12	TQ0CCPR11	TQ0CCPR10
FFFFF128H	TQ0CCIC2	TQ0CCIF2	TQ0CCMK2	0	0	0	TQ0CCPR22	TQ0CCPR21	TQ0CCPR20
FFFFF12AH	TQ0CCIC3	TQ0CCIF3	TQ0CCMK3	0	0	0	TQ0CCPR32	TQ0CCPR31	TQ0CCPR30
FFFFF12CH	TP0OVIC	TP0OVIF	TP0OVMK	0	0	0	TP0OVPR2	TP0OVPR1	TP0OVPR0
FFFFF12EH	TP0CCIC0	TP0CCIF0	TP0CCMK0	0	0	0	TP0CCPR02	TP0CCPR01	TP0CCPR00
FFFFF130H	TP0CCIC1	TP0CCIF1	TP0CCMK1	0	0	0	TP0CCPR12	TP0CCPR11	TP0CCPR10
FFFFF132H	TP1OVIC	TP1OVIF	TP1OVMK	0	0	0	TP1OVPR2	TP1OVPR1	TP1OVPR0
FFFFF134H	TP1CCIC0	TP1CCIF0	TP1CCMK0	0	0	0	TP1CCPR02	TP1CCPR01	TP1CCPR00
FFFFF136H	TP1CCIC1	TP1CCIF1	TP1CCMK1	0	0	0	TP1CCPR12	TP1CCPR11	TP1CCPR10
FFFFF138H	TP2OVIC	TP2OVIF	TP2OVMK	0	0	0	TP2OVPR2	TP2OVPR1	TP2OVPR0
FFFFF13AH	TP2CCIC0	TP2CCIF0	TP2CCMK0	0	0	0	TP2CCPR02	TP2CCPR01	TP2CCPR00
FFFFF13CH	TP2CCIC1	TP2CCIF1	TP2CCMK1	0	0	0	TP2CCPR12	TP2CCPR11	TP2CCPR10
FFFFF13EH	TP3OVIC	TP3OVIF	TP3OVMK	0	0	0	TP3OVPR2	TP3OVPR1	TP3OVPR0
FFFFF140H	TP3CCIC0	TP3CCIF0	TP3CCMK0	0	0	0	TP3CCPR02	TP3CCPR01	TP3CCPR00
FFFFF142H	TP3CCIC1	TP3CCIF1	TP3CCMK1	0	0	0	TP3CCPR12	TP3CCPR11	TP3CCPR10
FFFFF144H	TP4OVIC	TP4OVIF	TP4OVMK	0	0	0	TP4OVPR2	TP4OVPR1	TP4OVPR0
FFFFF146H	TP4CCIC0	TP4CCIF0	TP4CCMK0	0	0	0	TP4CCPR02	TP4CCPR01	TP4CCPR00
FFFFF148H	TP4CCIC1	TP4CCIF1	TP4CCMK1	0	0	0	TP4CCPR12	TP4CCPR11	TP4CCPR10
FFFFF14AH	TP5OVIC	TP5OVIF	TP5OVMK	0	0	0	TP5OVPR2	TP5OVPR1	TP5OVPR0
FFFFF14CH	TP5CCIC0	TP5CCIF0	TP5CCMK0	0	0	0	TP5CCPR02	TP5CCPR01	TP5CCPR00
FFFFF14EH	TP5CCIC1	TP5CCIF1	TP5CCMK1	0	0	0	TP5CCPR12	TP5CCPR11	TP5CCPR10
FFFFF150H	TM0EQIC0	TM0EQIF0	TM0EQMK0	0	0	0	TM0EQPR02	TM0EQPR01	TM0EQPR00
FFFFF152H	CB0RIC/ IICIC1	CB0RIF/ IICIF1	CB0RMK/ IICMK1	0	0	0	CB0RPR2/ IICPR12	CB0RPR1/ IICPR11	CB0RPR0/ IICPR10
FFFFF154H	CB0TIC	CB0TIF	CB0TMK	0	0	0	CB0TPR2	CB0TPR1	CB0TPR0
FFFFF156H	CB1RIC	CB1RIF	CB1RMK	0	0	0	CB1RPR2	CB1RPR1	CB1RPR0
FFFFF158H	CB1TIC	CB1TIF	CB1TMK	0	0	0	CB1TPR2	CB1TPR1	CB1TPR0
FFFFF15AH	CB2RIC	CB2RIF	CB2RMK	0	0	0	CB2RPR2	CB2RPR1	CB2RPR0
FFFFF15CH	CB2TIC	CB2TIF	CB2TMK	0	0	0	CB2TPR2	CB2TPR1	CB2TPR0
FFFFF15EH	CB3RIC	CB3RIF	CB3RMK	0	0	0	CB3RPR2	CB3RPR1	CB3RPR0
FFFFF160H	CB3TIC	CB3TIF	CB3TMK	0	0	0	CB3TPR2	CB3TPR1	CB3TPR0

Table 24-2. Interrupt Control Register (xxICn) (2/3)

Address	Register	Bit							
		<7>	<6>	5	4	3	2	1	0
FFFFF162H	UA0RIC/ CB4RIC	UA0RIF/ CB4RIF	UA0RMK/ CB4RMK	0	0	0	UA0RPR2/ CB4RPR2	UA0RPR1/ CB4RPR1	UA0RPR0/ CB4RPR0
FFFFF164H	UA0TIC/ CB4TIC	UA0TIF/ CB4TIF	UA0TMK/ CB4TMK	0	0	0	UA0TPR2/ CB4TPR2	UA0TPR1/ CB4TPR1	UA0TPR0/ CB4TPR0
FFFFF166H	UA1RIC	UA1RIF	UA1RMK	0	0	0	UA1RPR2	UA1RPR1	UA1RPR0
FFFFF168H	UA1TIC	UA1TIF	UA1TMK	0	0	0	UA1TPR2	UA1TPR1	UA1TPR0
FFFFF16AH	UA2RIC	UA2RIF	UA2RMK	0	0	0	UA2RPR2	UA2RPR1	UA2RPR0
FFFFF16CH	UA2TIC	UA2TIF	UA2TMK	0	0	0	UA2TPR2	UA2TPR1	UA2TPR0
FFFFF16EH	ADIC	ADIF	ADMK	0	0	0	ADPR2	ADPR1	ADPR0
FFFFF170H	DMAIC0	DMAIF0	DMAMK0	0	0	0	DMAPR02	DMAPR01	DMAPR00
FFFFF172H	DMAIC1	DMAIF1	DMAMK1	0	0	0	DMAPR12	DMAPR11	DMAPR10
FFFFF174H	DMAIC2	DMAIF2	DMAMK2	0	0	0	DMAPR22	DMAPR21	DMAPR20
FFFFF176H	DMAIC3	DMAIF3	DMAMK3	0	0	0	DMAPR32	DMAPR31	DMAPR30
FFFFF178H	KRIC	KRIF	KRMK	0	0	0	KRPR2	KRPR1	KRPR0
FFFFF17AH	WTIIC	WTIIF	WTIMK	0	0	0	WTIPR2	WTIPR1	WTIPR0
FFFFF17CH	WTIC	WTIF	WTMK	0	0	0	WTPR2	WTPR1	WTPR0
FFFFF17EH	ERRIC0 <sup>Note 1</sup>	ERRIF0	ERRMK0	0	0	0	ERRPR02	ERRPR01	ERRPR00
FFFFF180H	WUPIC0 <sup>Note 1</sup>	WUPIF0	WUPMK0	0	0	0	WUPPR02	WUPPR01	WUPPR00
FFFFF182H	RECIC0 <sup>Note 1</sup>	RECIF0	RECMK0	0	0	0	RECPR02	RECPR01	RECPR00
FFFFF184H	TRXIC0 <sup>Note 1</sup>	TRXIF0	TRXMK0	0	0	0	TRXPR02	TRXPR01	TRXPR00
FFFFF186H	ERRIC1 <sup>Note 2</sup>	ERRIF1	ERRMK1	0	0	0	ERRPR12	ERRPR11	ERRPR10
FFFFF188H	WUPIC1 <sup>Note 2</sup>	WUPIF1	WUPMK1	0	0	0	WUPPR12	WUPPR11	WUPPR10
FFFFF18AH	RECIC1 <sup>Note 2</sup>	RECIF1	RECMK1	0	0	0	RECPR12	RECPR11	RECPR10
FFFFF18CH	TRXIC1 <sup>Note 2</sup>	TRXIF1	TRXMK1	0	0	0	TRXPR12	TRXPR11	TRXPR10
FFFFF18EH	PIC8	PIF8	PMK8	0	0	0	PPR82	PPR81	PPR80
FFFFF190H	TP6OVIC	TP6OVIF	TP6OVMK	0	0	0	TP6OVPR2	TP6OVPR1	TP6OVPR0
FFFFF192H	TP6CCIC0	TP6CCIF0	TP6CCMK0	0	0	0	TP6CCPR02	TP6CCPR01	TP6CCPR00
FFFFF194H	TP6CCIC1	TP6CCIF1	TP6CCMK1	0	0	0	TP6CCPR12	TP6CCPR11	TP6CCPR10
FFFFF196H	TP7OVIC	TP7OVIF	TP7OVMK	0	0	0	TP7OVPR2	TP7OVPR1	TP7OVPR0
FFFFF198H	TP7CCIC0	TP7CCIF0	TP7CCMK0	0	0	0	TP7CCPR02	TP7CCPR01	TP7CCPR00
FFFFF19AH	TP7CCIC1	TP7CCIF1	TP7CCMK1	0	0	0	TP7CCPR12	TP7CCPR11	TP7CCPR10
FFFFF19CH	TP8OVIC	TP8OVIF	TP8OVMK	0	0	0	TP8OVPR2	TP8OVPR1	TP8OVPR0
FFFFF19EH	TP8CCIC0	TP8CCIF0	TP8CCMK0	0	0	0	TP8CCPR02	TP8CCPR01	TP8CCPR00
FFFFF1A0H	TP8CCIC1	TP8CCIF1	TP8CCMK1	0	0	0	TP8CCPR12	TP8CCPR11	TP8CCPR10
FFFFF1A2H	CB5RIC	CB5RIF	CB5RMK	0	0	0	CB5RPR2	CB5RPR1	CB5RPR0
FFFFF1A4H	CB5TIC	CB5TIF	CB5TMK	0	0	0	CB5TPR2	CB5TPR1	CB5TPR0
FFFFF1A6H	UA3RIC	UA3RIF	UA3RMK	0	0	0	UA3RPR2	UA3RPR1	UA3RPR0
FFFFF1A8H	UA3TIC	UA3TIF	UA3TMK	0	0	0	UA3TPR2	UA3TPR1	UA3TPR0

- Notes 1.** CAN controller version only  
**2.** CAN controller (2-channel) version only

Table 24-2. Interrupt Control Register (xxlCn) (3/3)

Address	Register	Bit							
		<7>	<6>	5	4	3	2	1	0
FFFFF1B0H	UA4RIC	UA4RIF	UA4RMK	0	0	0	UA4RPR2	UA4RPR1	UA4RPR0
FFFFF1B2H	UA4TIC	UA4TIF	UA4TMK	0	0	0	UA4TPR2	UA4TPR1	UA4TPR0
FFFFF1B4H	IICIC3	IICIF3	IICMK3	0	0	0	IICPR32	IICPR31	IICPR30
FFFFF1B6H	IICIC0	IICIF0	IICMK0	0	0	0	IICPR02	IICPR01	IICPR00
FFFFF1B8H	IICIC2	IICIF2	IICMK2	0	0	0	IICPR22	IICPR21	IICPR20
<R> FFFFF1BAH	IICIC4 <sup>Note</sup>	IICIF4	IICMK4	0	0	0	IICPR42	IICPR41	IICPR40
<R> FFFFF1BCH	IICIC5 <sup>Note</sup>	IICIF5	IICMK5	0	0	0	IICPR52	IICPR51	IICPR50
FFFFF1BEH	PIC9	PIF9	PMK9	0	0	0	PPR92	PPR91	PPR90
FFFFF1C0H	TP7IECIC	TP7IECIF	TP7IECMK	0	0	0	TP7IECPR2	TP7IECPR1	TP7IECPR0
FFFFF1C2H	TP8IECIC	TP8IECIF	TP8IECMK	0	0	0	TP8IECPR2	TP8IECPR1	TP8IECPR0
FFFFF1C4H	TM1EQIC0	TM1EQIF0	TM1EQMK0	0	0	0	TM1EQPR02	TM1EQPR01	TM1EQPR00
FFFFF1C6H	TM2EQIC0	TM2EQIF0	TM2EQMK0	0	0	0	TM2EQPR02	TM2EQPR01	TM2EQPR00
<R> FFFFF1C8H	CE0TIC <sup>Note</sup>	CE0TIF	CE0TMK	0	0	0	CE0TPR2	CE0TPR1	CE0TPR0
<R> FFFFF1CAH	CE0TIOFIC <sup>Note</sup>	CE0TIOFIF	CE0TIOFMK	0	0	0	CE0TIOFPR2	CE0TIOFPR1	CE0TIOFPR0
<R> FFFFF1CCH	CE1TIC <sup>Note</sup>	CE1TIF	CE1TMK	0	0	0	CE1TPR2	CE1TPR1	CE1TPR0
<R> FFFFF1CEH	CE1TIOFIC <sup>Note</sup>	CE1TIOFIF	CE1TIOFMK	0	0	0	CE1TIOFPR2	CE1TIOFPR1	CE1TIOFPR0
FFFFF1D0H	UB0TIRIC	UB0TIRIF	UB0TIRMK	0	0	0	UB0TIRPR2	UB0TIRPR1	UB0TIRPR0
FFFFF1D2H	UB0TITIC	UB0TITIF	UB0TITMK	0	0	0	UB0TITPR2	UB0TITPR1	UB0TITPR0
FFFFF1D4H	UB0TIFIC	UB0TIFIF	UB0TIFMK	0	0	0	UB0TIFPR2	UB0TIFPR1	UB0TIFPR0
FFFFF1D6H	UB0TIREIC	UB0TIREIF	UB0TIREMK	0	0	0	UB0TIREPR2	UB0TIREPR1	UB0TIREPR0
FFFFF1D8H	UB0TITOIC	UB0TITOIF	UB0TITOMK	0	0	0	UB0TITOPR2	UB0TITOPR1	UB0TITOPR0
FFFFF1DAH	UB1TIRIC	UB1TIRIF	UB1TIRMK	0	0	0	UB1TIRPR2	UB1TIRPR1	UB1TIRPR0
FFFFF1DCH	UB1TITIC	UB1TITIF	UB1TITMK	0	0	0	UB1TITPR2	UB1TITPR1	UB1TITPR0
FFFFF1DEH	UB1TIFIC	UB1TIFIF	UB1TIFMK	0	0	0	UB1TIFPR2	UB1TIFPR1	UB1TIFPR0
FFFFF1E0H	UB1TIREIC	UB1TIREIF	UB1TIREMK	0	0	0	UB1TIREPR2	UB1TIREPR1	UB1TIREPR0
FFFFF1E2H	UB1TITOIC	UB1TITOIF	UB1TITOMK	0	0	0	UB1TITOPR2	UB1TITOPR1	UB1TITOPR0
FFFFF1E4H	UA5RIC	UA5RIF	UA5RMK	0	0	0	UA5RPR2	UA5RPR1	UA5RPR0
FFFFF1E6H	UA5TIC	UA5TIF	UA5TMK	0	0	0	UA5TPR2	UA5TPR1	UA5TPR0
FFFFF1E8H	ERRIC	ERRIF	ERRMK	0	0	0	ERRPR2	ERRPR1	ERRPR0
FFFFF1EAH	STAIC	STAIF	STAMK	0	0	0	STAPR2	STAPR1	STAPR0
FFFFF1ECH	IEIC1	IEIF1	IEMK1	0	0	0	IEPR12	IEPR11	IEPR10
FFFFF1EEH	IEIC2	IEIF2	IEMK2	0	0	0	IEPR22	IEPR21	IEPR20
FFFFF1F0H	RTC0IC	RTC0IF	RTC0MK	0	0	0	RTC0PR2	RTC0PR1	RTC0PR0
FFFFF1F2H	RTC1IC	RTC1IF	RTC1MK	0	0	0	RTC1PR2	RTC1PR1	RTC1PR0
FFFFF1F4H	RTC2IC	RTC2IF	RTC2MK	0	0	0	RTC2PR2	RTC2PR1	RTC2PR0

<R> **Note** Not available in the  $\mu$ PD70F3931 (V850E/SJ3-H), 70F3932 (V850E/SJ3-H), and 70F3933 (V850E/SJ3-H)

### 24.3.5 Interrupt mask registers 0 to 6, 7L (IMR0 to IMR6, IMR7L)

The IMR0 to IMR6 and IMR7L registers set the interrupt mask state for the maskable interrupts. The xxMKn bit of the IMR0 to IMR6 and IMR7L registers is equivalent to the xxICn.xxMKn bit.

The IMRm register can be read or written in 16-bit units (m = 0 to 6).

If the higher 8 bits of the IMRm register are used as an IMRmH register and the lower 8 bits as an IMRmL register, these registers can be read or written in 8-bit or 1-bit units (m = 0 to 6).

The IMR7L register can be read or written in 8-bit or 1-bit units.

Reset sets these registers to FFFFH.

**Caution** The device file defines the xxICn.xxMKn bit as a reserved word. If a bit is manipulated using the name of xxMKn, the contents of the xxICn register, instead of the IMRm and IMR7L registers, are rewritten (as a result, the contents of the IMRm and IMR7L registers are also rewritten).

After reset: 1FH R/W Address: IMR7L FFFF10EH

	7	6	5	4	3	2	1	0
IMR7L	0	0	0	1	1	RTC2MK	RTC1MK	RTC0MK

After reset: FFFFH R/W Address: IMR6 FFFF10CH,  
IMR6L FFFF10CH, IMR6H FFFF10DH

	15	14	13	12	11	10	9	8
IMR6 (IMR6H <sup>Note 1</sup> )	IEMK2	IEMK1	STAMK	ERRMK	UA5TMK	UA5RMK	UB1TITOMK	UB1TIREMK
	7	6	5	4	3	2	1	0
IMR6L	UB1TIFMK	UB1TITMK	UB1TIRMK	UB0TITOMK	UB0TIREMK	UB0TIFMK	UB0TITMK	UB0TIRMK

After reset: FFFFH R/W Address: IMR5 FFFF10AH,  
IMR5L FFFF10AH, IMR5H FFFF10BH

<R>

	15	14	13	12	11	10	9	8
IMR5 (IMR5H <sup>Note 1</sup> )	CE1TIOFMK <sup>Note 2</sup>	CE1TMK <sup>Note 2</sup>	CE0TIOFMK <sup>Note 2</sup>	CE0TMK <sup>Note 2</sup>	TM2EQMK0	TM1EQMK0	TP8IECMK	TP7IECMK
	7	6	5	4	3	2	1	0
IMR5L	PMK9	IICMK5 <sup>Note 2</sup>	IICMK4 <sup>Note 2</sup>	IICMK2	IICMK0	IICMK3	UA4TMK	UA4RMK

<R>

After reset: FFFFH R/W Address: IMR4 FFFF108H,  
IMR4L FFFF108H, IMR4H FFFF109H

	15	14	13	12	11	10	9	8
IMR4 (IMR4H <sup>Note 1</sup> )	1	1	1	UA3TMK	UA3RMK	CB5TMK	CB5RMK	TP8CCMK1
	7	6	5	4	3	2	1	0
IMR4L	TP8CCMK0	TP8OVMK	TP7CCMK1	TP7CCMK0	TP7OVMK	TP6CCMK1	TP6CCMK0	TP6OVMK

After reset: FFFFH R/W Address: IMR3 FFFF106H,  
IMR3L FFFF106H, IMR3H FFFF107H

	15	14	13	12	11	10	9	8
IMR3 (IMR3H <sup>Note 1</sup> )	PMK8	TRXMK1 <sup>Note 3</sup>	RECMK1 <sup>Note 3</sup>	WUPMK1 <sup>Note 3</sup>	ERRMK1 <sup>Note 3</sup>	TRXMK0 <sup>Note 4</sup>	RECMK0 <sup>Note 4</sup>	WUPMK0 <sup>Note 4</sup>
	7	6	5	4	3	2	1	0
IMR3L	ERRMK0 <sup>Note 4</sup>	WTMK	WTIMK	KRMK	DMAMK3	DMAMK2	DMAMK1	DMAMK0

After reset: FFFFH R/W Address: IMR2 FFFF104H,  
IMR2L FFFF104H, IMR2H FFFF105H

	15	14	13	12	11	10	9	8
IMR2 (IMR2H <sup>Note 1</sup> )	ADMK	UA2TMK	UA2RMK	UA1TMK	UA1RMK	UA0TMK/ CB4TMK	UA0RMK/ CB4RMK	CB3TMK
	7	6	5	4	3	2	1	0
IMR2L	CB3RMK	CB2TMK	CB2RMK	CB1TMK	CB1RMK	CB0TMK	CB0RMK/ IICMK1	TM0EQMK0

After reset: FFFFH R/W Address: IMR1 FFFF102H,  
IMR1L FFFF102H, IMR1H FFFF103H

	15	14	13	12	11	10	9	8
IMR1 (IMR1H <sup>Note 1</sup> )	TP5CCMK1	TP5CCMK0	TP5OVMK	TP4CCMK1	TP4CCMK0	TP4OVMK	TP3CCMK1	TP3CCMK0
	7	6	5	4	3	2	1	0
IMR1L	TP3OVMK	TP2CCMK1	TP2CCMK0	TP2OVMK	TP1CCMK1	TP1CCMK0	TP1OVMK	TP0CCMK1

After reset: FFFFH R/W Address: IMR0 FFFF100H,  
IMR0L FFFF100H, IMR0H FFFF101H

	15	14	13	12	11	10	9	8
IMR0 (IMR0H <sup>Note 1</sup> )	TP0CCMK0	TP0OVMK	TQ0CCMK3	TQ0CCMK2	TQ0CCMK1	TQ0CCMK0	TQ0OVMK	PMK7
	7	6	5	4	3	2	1	0
IMR0L	PMK6	PMK5	PMK4	PMK3	PMK2	PMK1	PMK0	LVIMK

xxMKn	Setting of interrupt mask flag
0	Interrupt servicing enabled
1	Interrupt servicing disabled

**Notes 1.** To read bits 8 to 15 of the IMR0 to IMR6 registers in 8-bit or 1-bit units, specify them as bits 0 to 7 of the IMR0H to IMR6H registers.

**2.** Not available in the  $\mu$ PD70F3931 (V850E/SJ3-H), 70F3932 (V850E/SJ3-H), and 70F3933 (V850E/SJ3-H).

Be sure to set these bits to 1 in the  $\mu$ PD70F3931 (V850E/SJ3-H), 70F3932 (V850E/SJ3-H), and 70F3933 (V850E/SJ3-H).

**3.** CAN controller (2-channel) versions only.

Be sure to set the registers to 1 when other than the above.

**4.** CAN controller versions only.

Be sure to set the registers to 1 when other than the above.

**Caution** Set bits 13 to 15 of the IMR4 register and bits 3 and 4 of the IMR7L register to 1, and set bits 5 to 7 of the IMR7L register to 0. If the setting of these bits is changed, the operation is not guaranteed.

**Remark** xx: Identification name of each peripheral unit (see **Table 24-2 Interrupt Control Register (xxICn)**).

n: Peripheral unit number (see **Table 24-2 Interrupt Control Register (xxICn)**)

<R>



**24.3.6 In-service priority register (ISPR)**

The ISPR register holds the priority level of the maskable interrupt currently acknowledged. When an interrupt request signal is acknowledged, the bit of this register corresponding to the priority level of that interrupt request signal is set to 1 and remains set while the interrupt is serviced.

When the RETI instruction is executed, the bit corresponding to the interrupt request signal having the highest priority is automatically cleared to 0 by hardware. However, it is not cleared to 0 when execution is returned from non-maskable interrupt servicing or exception processing.

This register is read-only, in 8-bit or 1-bit units.

Reset sets this register to 00H.

**Caution** If an interrupt is acknowledged while the ISPR register is being read in the interrupt enabled (EI) status, the value of the ISPR register after the bits of the register have been set by acknowledging the interrupt may be read. To accurately read the value of the ISPR register before an interrupt is acknowledged, read the register while interrupts are disabled (DI).

After reset: 00H	R	Address: FFFFF1FAH						
ISPR	<7>	<6>	<5>	<4>	<3>	<2>	<1>	<0>
	ISPR7	ISPR6	ISPR5	ISPR4	ISPR3	ISPR2	ISPR1	ISPR0
	ISPRn	Priority of interrupt currently acknowledged						
	0	Interrupt request signal with priority n not acknowledged						
	1	Interrupt request signal with priority n acknowledged						

**Remark** n = 0 to 7 (priority level)

**24.3.7 ID flag**

This flag controls the maskable interrupt’s operating state, and stores control information regarding enabling or disabling of interrupt request signals. An interrupt disable flag (ID) is assigned to the PSW.

Reset sets this flag to 00000020H.

After reset: 00000020H

31	8	7	6	5	4	3	2	1	0		
PSW	0			NP	EP	ID	SAT	CY	OV	S	Z

ID	Specification of maskable interrupt servicing <sup>Note</sup>
0	Maskable interrupt request signal acknowledgment enabled
1	Maskable interrupt request signal acknowledgment disabled (pending)

**Note** Interrupt disable flag (ID) function

This bit is set to 1 by the DI instruction and cleared to 0 by the EI instruction. Its value is also modified by the RETI instruction or LDSR instruction when referencing the PSW.

Non-maskable interrupt request signals and exceptions are acknowledged regardless of this flag. When a maskable interrupt request signal is acknowledged, the ID flag is automatically set to 1 by hardware.

The interrupt request signal generated during the acknowledgment disabled period (ID flag = 1) is acknowledged when the xxICn.xxIFn bit is set to 1, and the ID flag is cleared to 0.

**24.3.8 Watchdog timer mode register 2 (WDTM2)**

This register can be read or written in 8-bit units (for details, see **CHAPTER 11 FUNCTIONS OF WATCHDOG TIMER 2**).

Reset sets this register to 67H.

After reset: 67H    R/W    Address: FFFFF6D0H

7	6	5	4	3	2	1	0
WDTM2	0	WDM21	WDM20	0	0	0	0

WDM21	WDM20	Selection of watchdog timer operation mode
0	0	Stops operation
0	1	Non-maskable interrupt request mode
1	×	Reset mode (initial-value)

## 24.4 Software Exception

A software exception is generated when the CPU executes the TRAP instruction, and can always be acknowledged.

### 24.4.1 Operation

If a software exception occurs, the CPU performs the following processing, and transfers control to the handler routine.

- <1> Saves the restored PC to EIPC.
- <2> Saves the current PSW to EIPSW.
- <3> Writes an exception code to the lower 16 bits (EICC) of ECR (interrupt source).
- <4> Sets the PSW.EP and PSW.ID bits to 1.
- <5> Sets the handler address (00000040H or 00000050H) corresponding to the software exception to the PC, and transfers control.

Figure 24-9 illustrates the processing of a software exception.

**Figure 24-9. Software Exception Processing**

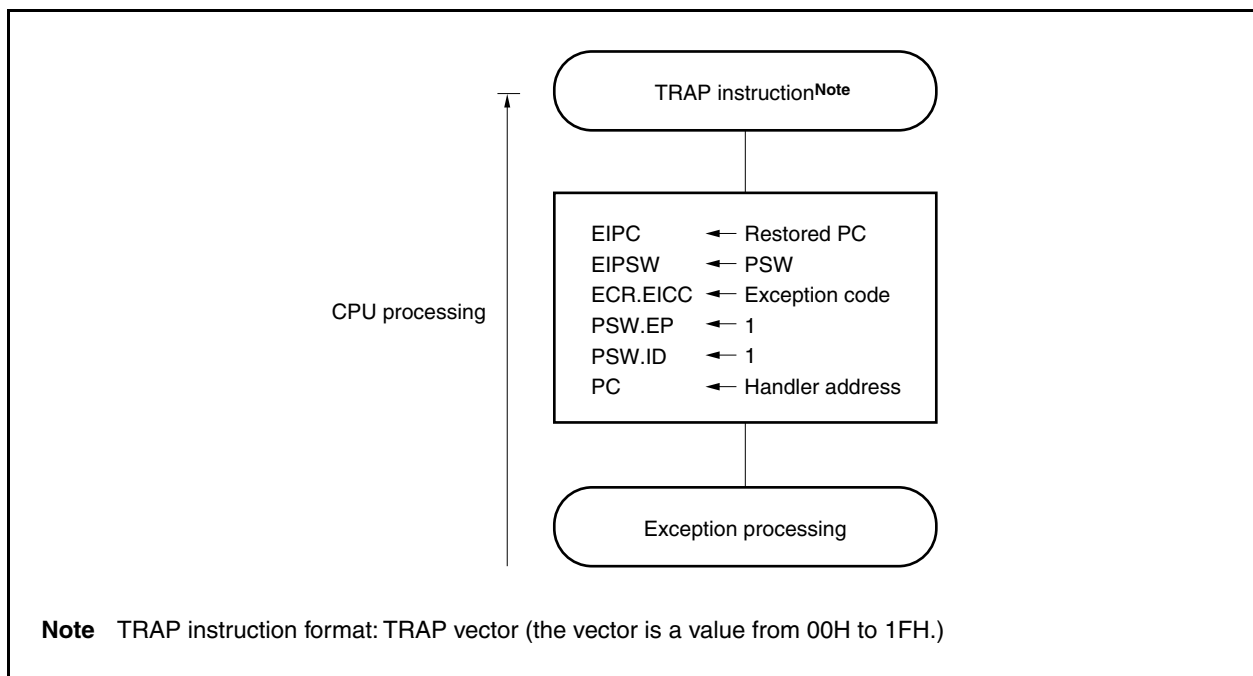

The handler address is determined by the TRAP instruction's operand (vector). If the vector is 00H to 0FH, it becomes 00000040H, and if the vector is 10H to 1FH, it becomes 00000050H.

### 24.4.2 Restore

Recovery from software exception processing is carried out by the RETI instruction.

By executing the RETI instruction, the CPU carries out the following processing and shifts control to the restored PC's address.

- <1> Loads the restored PC and PSW from EIPC and EIPSW because the PSW.EP bit is 1.
- <2> Transfers control to the address of the restored PC and PSW.

Figure 24-10 illustrates the processing of the RETI instruction.

**Figure 24-10. RETI Instruction Processing**

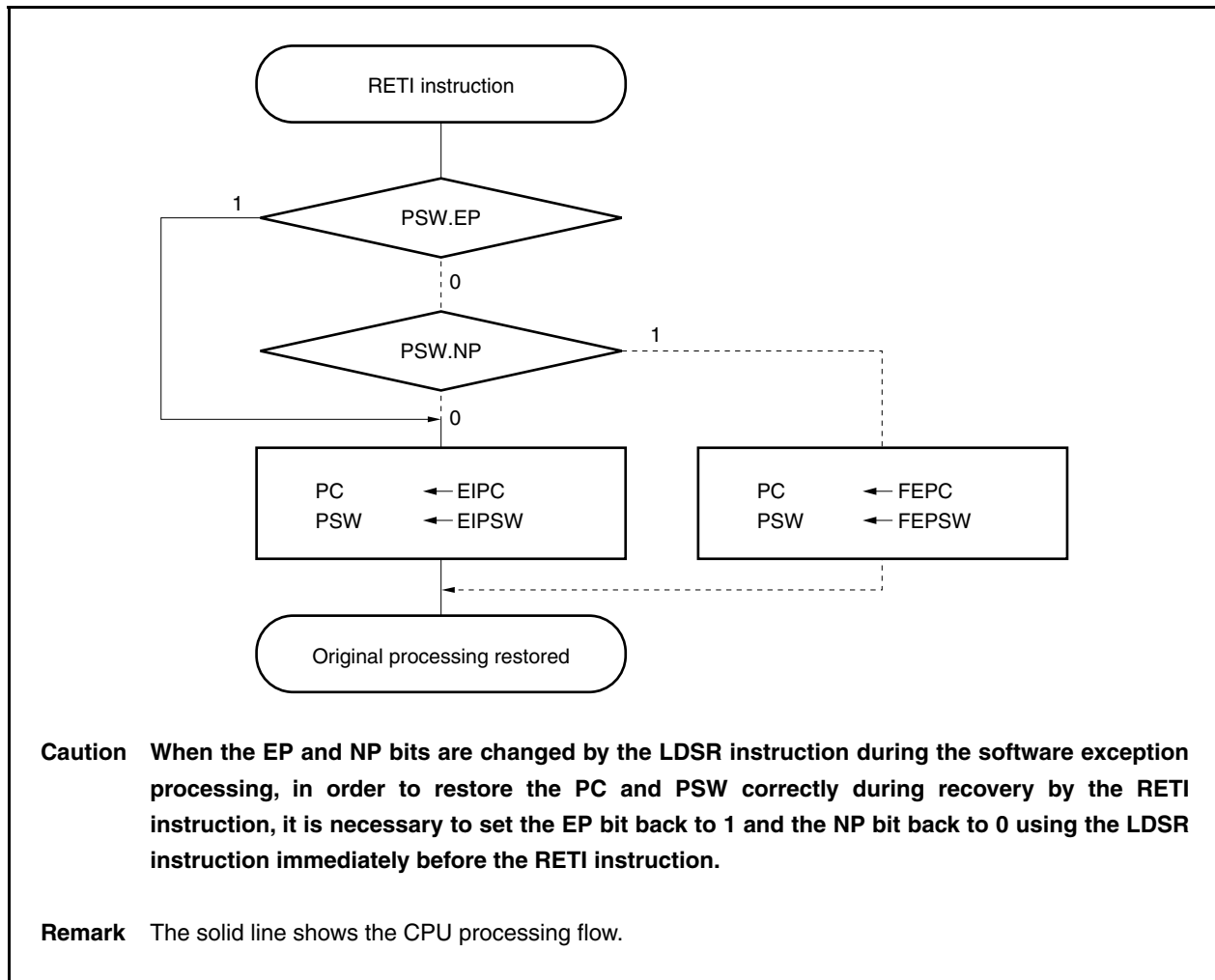

**24.4.3 EP flag**

The EP flag is a status flag used to indicate that exception processing is in progress. It is set when an exception occurs.

After reset: 00000020H

	31		8	7	6	5	4	3	2	1	0
PSW	0			NP	<b>EP</b>	ID	SAT	CY	OV	S	Z

EP	Exception processing status
0	Exception processing not in progress.
1	Exception processing in progress.

## 24.5 Exception Trap

An exception trap is an interrupt that is requested when the illegal execution of an instruction takes place. In the V850E/SJ3-H and V850E/SK3-H, an illegal opcode exception (ILGOP: Illegal Opcode Trap) is considered as an exception trap.

### 24.5.1 Illegal opcode definition

The illegal instruction has an opcode (bits 10 to 5) of 11111B, a sub-opcode (bits 26 to 23) of 0111B to 1111B, and a sub-opcode (bit 16) of 0B. An exception trap is generated when an instruction applicable to this illegal instruction is executed.

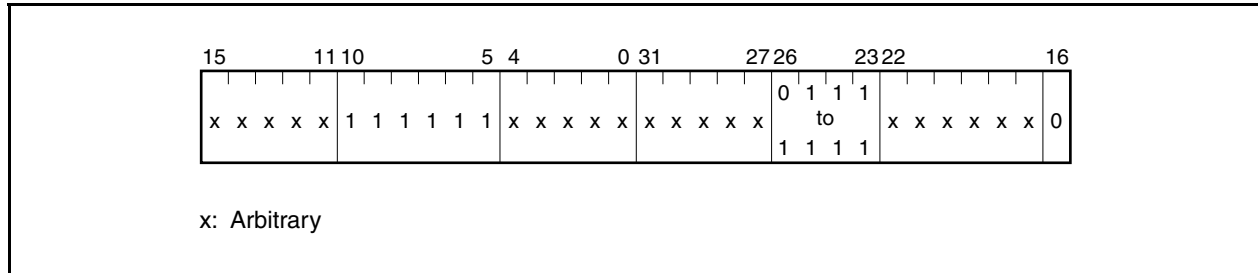

**Caution** Since it is possible to assign this instruction to an illegal opcode in the future, it is recommended that it not be used.

#### (1) Operation

If an exception trap occurs, the CPU performs the following processing, and transfers control to the handler routine.

- <1> Saves the restored PC to DBPC.
- <2> Saves the current PSW to DBPSW.
- <3> Sets the PSW.NP, PSW.EP, and PSW.ID bits to 1.
- <4> Sets the handler address (00000060H) corresponding to the exception trap to the PC, and transfers control.

Figure 24-11 illustrates the processing of the exception trap.

Figure 24-11. Exception Trap Processing

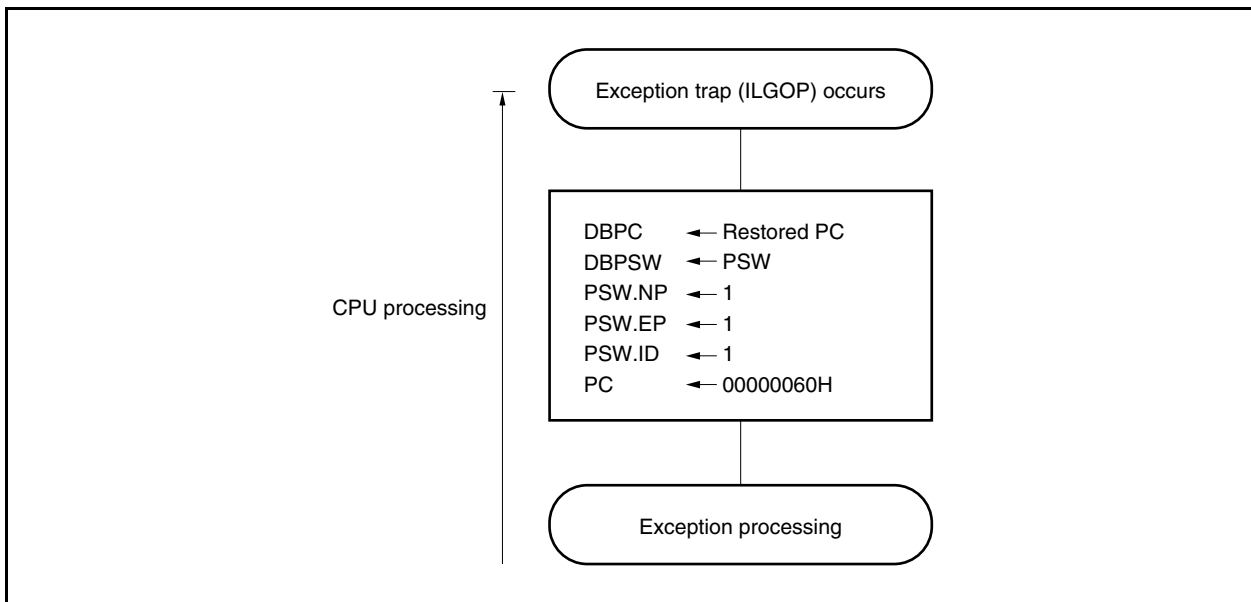
**(2) Restore**

Recovery from an exception trap is carried out by the DBRET instruction. By executing the DBRET instruction, the CPU carries out the following processing and controls the address of the restored PC.

- <1> Loads the restored PC and PSW from DBPC and DBPSW.
- <2> Transfers control to the address indicated by the restored PC and PSW.

**Caution** DBPC and DBPSW can be accessed after the illegal opcode is executed and before the DBRET instruction is executed.

Figure 24-12 illustrates the restore processing from an exception trap.

Figure 24-12. Restore Processing from Exception Trap

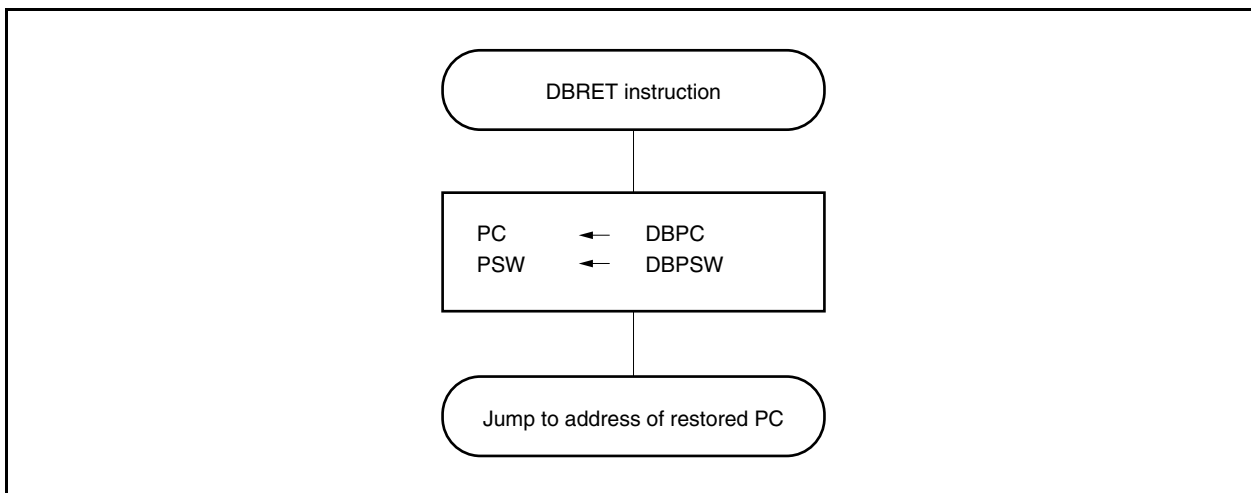

### 24.5.2 Debug trap

A debug trap is an exception that is generated when the DBTRAP instruction is executed and is always acknowledged.

#### (1) Operation

Upon occurrence of a debug trap, the CPU performs the following processing.

- <1> Saves restored PC to DBPC.
- <2> Saves current PSW to DBPSW.
- <3> Sets the PSW.NP, PSW.EP, and PSW.ID bits to 1.
- <4> Sets handler address (00000060H) for debug trap to PC and transfers control.

Figure 24-13 shows the debug trap processing format.

**Figure 24-13. Debug Trap Processing Format**

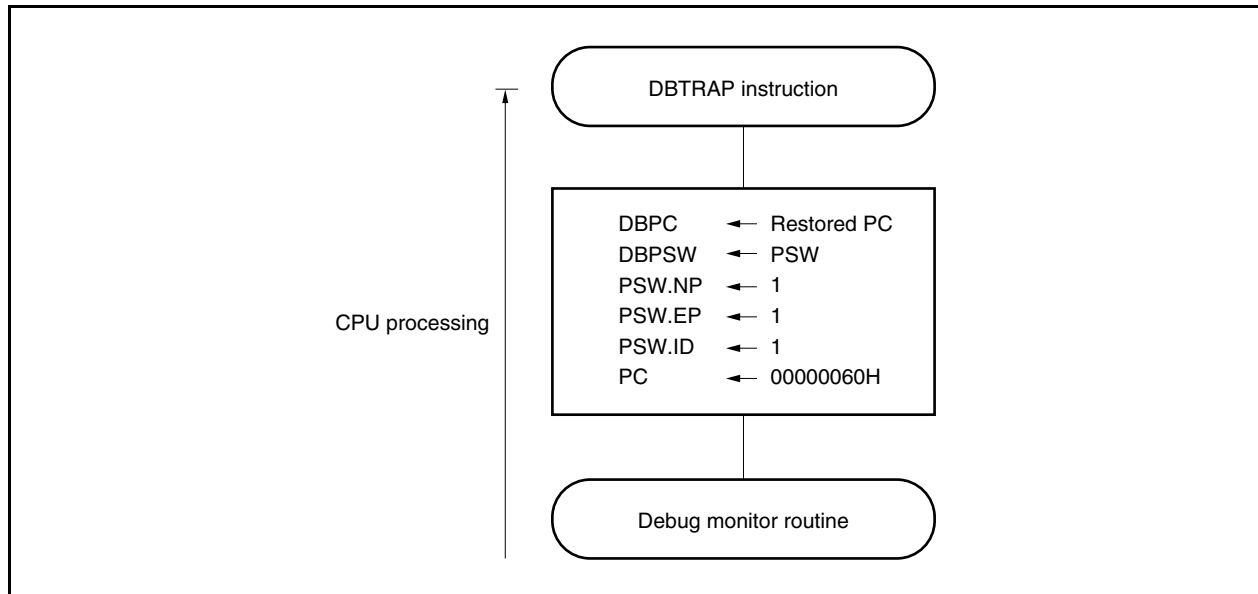



**(2) Restoration**

Restoration from a debug trap is executed with the DBRET instruction.

With the DBRET instruction, the CPU performs the following steps and transfers control to the address of the restored PC.

<1> The restored PC and PSW are read from DBPC and DBPSW.

<2> Control is transferred to the fetched address of the restored PC and PSW.

**Caution** DBPC and DBPSW can be accessed after the DBTRAP instruction is executed and before the DBRET instruction is executed.

Figure 24-14 shows the processing format for restoration from a debug trap.

**Figure 24-14. Processing Format of Restoration from Debug Trap**

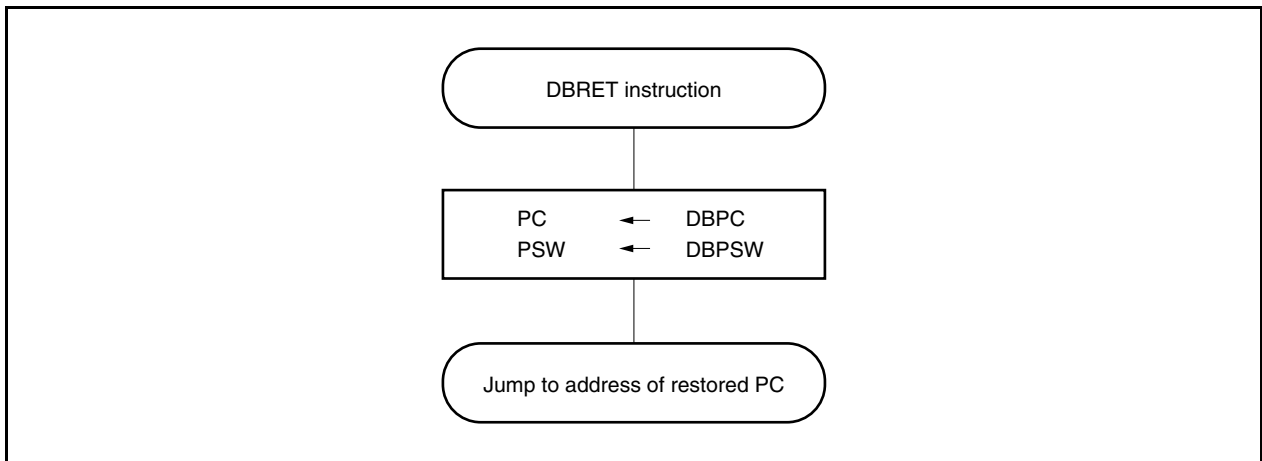

## 24.6 External Interrupt Request Input Pins (NMI and INTP0 to INTP9)

### 24.6.1 Noise elimination

#### (1) Eliminating noise on NMI pin

The NMI pin has an internal noise elimination circuit that uses analog delay. Therefore, the input level of the NMI pin is not detected as an edge unless it is maintained for a specific time or longer. Therefore, an edge is detected after specific time.

The NMI pin can be used to release the STOP mode. In the STOP mode, noise is not eliminated by using the system clock because the internal system clock is stopped.

#### (2) Eliminating noise on INTP0 to INTP9 pins

The INTP0 to INTP9 pins have an internal noise elimination circuit that uses analog delay. Therefore, the input level of the NMI pin is not detected as an edge unless it is maintained for a specific time or longer. Therefore, an edge is detected after specific time.

### 24.6.2 Edge detection

The valid edge of each of the NMI and INTP0 to INTP9 pins can be selected from the following four.

- Rising edge
- Falling edge
- Both rising and falling edges
- No edge detected

**Cautions 1. The edge of the NMI pin is not detected after reset. Therefore, the interrupt request signal is not acknowledged unless a valid edge is enabled by using the INTF0 and INTR0 register (the NMI pin functions as a normal port pin).**

- 2. In V850E/SJ3-H and V850E/SK3-H, the same external interrupt request input pins are assigned to two ports. Therefore, the setting of each valid edge is set independently in the register corresponding to each port.**

**Be sure to use the external interrupt request input pin in either of the two ports. Set the valid edge detection of the external interrupt request input pin of the port not being used to “No edge detected”.**

- Relationship between the external interrupt request input pin and the valid edge setting register sharing one port

(a) V850E/SJ3-H

Pin Name	Port <1>			Port <2>		
	Pin No.	Port Function	Valid Edge Setting Register	Pin No.	Port Function	Valid Edge Setting Register
INTP2	20	P05	INTF0.INTF05, INTR0.INTR05	24	P42	INTF4.INTF42, INTR4.INTR42
INTP5	75	P914	INTF9.INTF914, INTR9.INTR914	66	P95	INTF9L.INTF95, INTR9L.INTR95
INTP7	26	P31	INTF3.INTF31, INTR3.INTR31	38	P51	INTF5.INTF51, INTR5.INTR51
INTP8	59	P80	INTF8.INTF80, INTR8.INTR80	64	P93	INTF9L.INTF93, INTR9L.INTR93

(b) V850E/SK3-H

Pin Name	Port <1>			Port <2>		
	Pin No.	Port Function	Valid Edge Setting Register	Pin No.	Port Function	Valid Edge Setting Register
INTP2	22	P05	INTF0.INTF05, INTR0.INTR05	26	P42	INTF4.INTF42, INTR4.INTR42
INTP5	91	P914	INTF9.INTF914, INTR9.INTR914	82	P95	INTF9L.INTF95, INTR9L.INTR95
INTP6	92	P915	INTF9.INTF915, INTR9.INTR915	96	P153	INTF15.INTF153, INTR15.INTR153
INTP7	31	P31	INTF3.INTF31, INTR3.INTR31	46	P51	INTF5.INTF51, INTR5.INTR51
INTP8	71	P80	INTF8.INTF80, INTR8.INTR80	80	P93	INTF9L.INTF93, INTR9L.INTR93
INTP9	59	P66	INTF6.INTF66, INTR6.INTR66	95	P152	INTF15.INTF152, INTR15.INTR152

**(1) External interrupt falling, rising edge specification register 0 (INTF0, INTR0)**

The INTF0 and INTR0 registers are 8-bit registers that specify detection of the falling and rising edges of the NMI pin via bit 2 and the external interrupt pins (INTP0 to INTP3) via bits 3 to 6.

These registers can be read or written in 8-bit or 1-bit units.

Reset sets these registers to 00H.

**Caution** When the function is changed from the external interrupt function (alternate function) to the port function, an edge may be detected. Therefore, clear the INTF0n and INTR0n bits to 00, and then set the port mode.

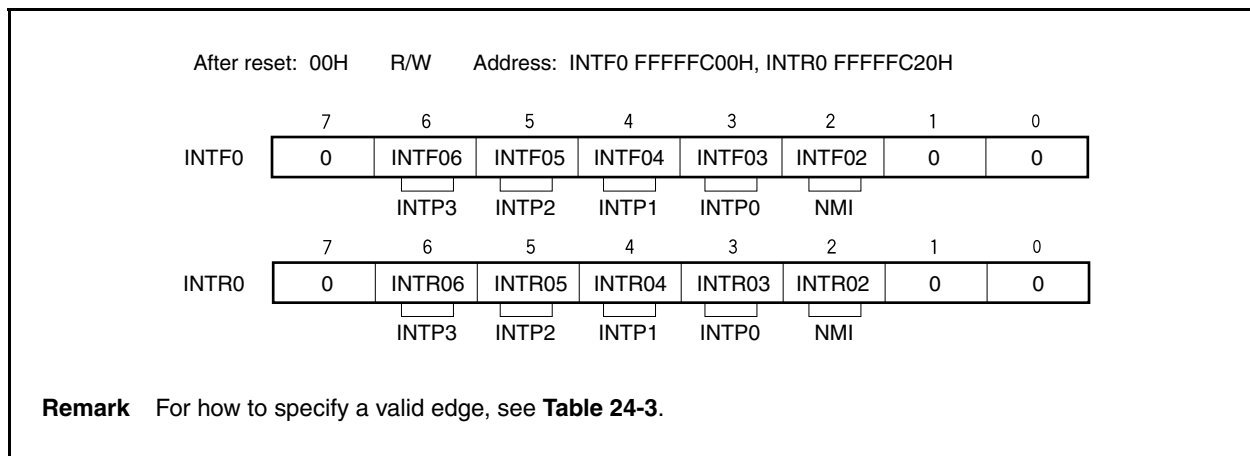

**Table 24-3. Valid Edge Specification**

INTF0n	INTR0n	Valid Edge Specification (n = 2 to 6)
0	0	No edge detected
0	1	Rising edge
1	0	Falling edge
1	1	Both rising and falling edges

**Caution** Be sure to clear the INTF0n and INTR0n bits to 00 when these registers are not used as the NMI or INTP0 to INTP3 pins.

**Remark** n = 2: Control of NMI pin  
 n = 3 to 6: Control of INTP0 to INTP3 pins

**(2) External interrupt falling, rising edge specification register 3 (INTF3, INTR3)**

The INTF3 and INTR3 registers are 8-bit registers that specify detection of the falling and rising edges of the external interrupt pin (INTP7).

These registers can be read or written in 8-bit or 1-bit units.

Reset sets these registers to 00H.

- Cautions**
1. When the function is changed from the external interrupt function (alternate function) to the port function, an edge may be detected. Therefore, clear the INTF31 and INTR31 bits to 00, and then set the port mode.
  2. The INTP7 pin and RXDA0 pin are alternate-function pins. When using the pin as the RXDA0 pin, disable edge detection for the INTP7 alternate-function pin (clear the INTF3.INTF31 bit and the INTR3.INTR31 bit to 0). When using the pin as the INTP7 pin, stop UARTA0 reception (clear the UA0CTL0.UA0RXE bit to 0).

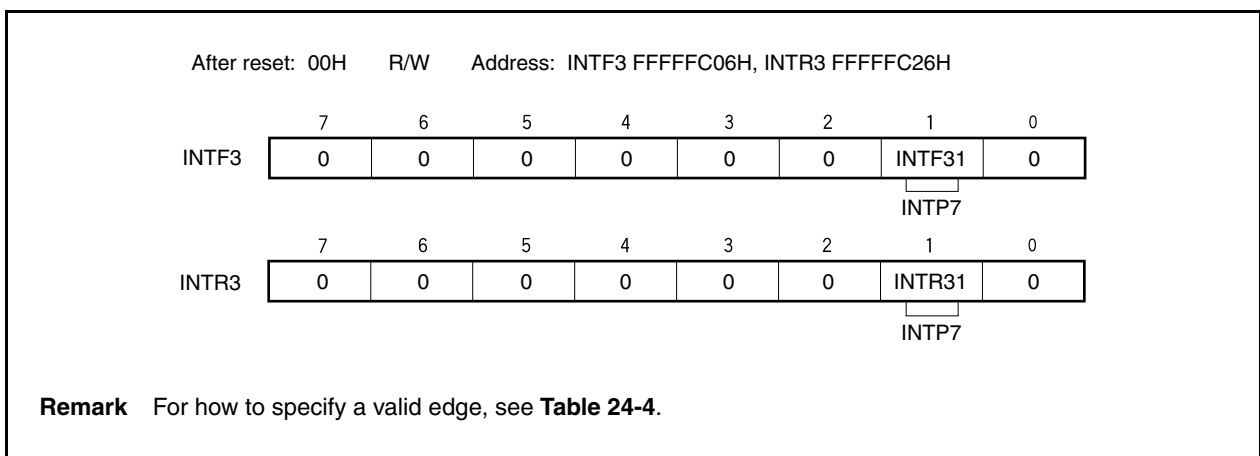

**Table 24-4. Valid Edge Specification**

INTF31	INTR31	Valid Edge Specification
0	0	No edge detected
0	1	Rising edge
1	0	Falling edge
1	1	Both rising and falling edges

**Caution** Be sure to clear the INTF31 and INTR31 bits to 00 when these registers are not used as INTP7 pin.

**(3) External interrupt falling, rising edge specification register 4 (INTF4, INTR4)**

The INTF4 and INTR4 registers are 8-bit registers that specify detection of the falling and rising edges of the external interrupt pin (INTP2).

These registers can be read or written in 8-bit or 1-bit units.

Reset sets these registers to 00H.

**Caution** When the function is changed from the external interrupt function (alternate function) to the port function, an edge may be detected. Therefore, clear the INTF42 and INTR42 bits to 00, and then set the port mode.

After reset: 00H    R/W    Address: INTF4 FFFFFFFC08H, INTR4 FFFFFFFC28H

INTF4	7	6	5	4	3	2	1	0
	0	0	0	0	0	INTF42	0	0

└──────────┘  
INTP2

INTR4	7	6	5	4	3	2	1	0
	0	0	0	0	0	INTR42	0	0

└──────────┘  
INTP2

**Remark** For how to specify a valid edge, see **Table 24-5**.

**Table 24-5. Valid Edge Specification**

INTF42	INTR42	Valid Edge Specification
0	0	No edge detected
0	1	Rising edge
1	0	Falling edge
1	1	Both rising and falling edges

**Caution** Be sure to clear the INTF42 and INTR42 bits to 00 when these registers are not used as INTP2 pin.

**(4) External interrupt falling, rising edge specification register 5 (INTF5, INTR5)**

The INTF5 and INTR5 registers are 8-bit registers that specify detection of the falling and rising edges of the external interrupt pin (INTP7).

These registers can be read or written in 8-bit or 1-bit units.

Reset sets these registers to 00H.

**Caution** When the function is changed from the external interrupt function (alternate function) to the port function, an edge may be detected. Therefore, clear the INTF51 and INTR51 bits to 00, and then set the port mode.

After reset: 00H    R/W    Address: INTF5 FFFFFFFC0AH, INTR5 FFFFFFFC2AH

INTF5	7	6	5	4	3	2	1	0
	0	0	0	0	0	0	INTF51	0
							┌	
							└	INTP7
INTR5	7	6	5	4	3	2	1	0
	0	0	0	0	0	0	INTR51	0
							┌	
							└	INTP7

**Remark** For how to specify a valid edge, see **Table 24-6**.

**Table 24-6. Valid Edge Specification**

INTF51	INTR51	Valid Edge Specification
0	0	No edge detected
0	1	Rising edge
1	0	Falling edge
1	1	Both rising and falling edges

**Caution** Be sure to clear the INTF51 and INTR51 bits to 00 when these registers are not used as INTP7 pin.

**(5) External interrupt falling, rising edge specification register 6 (INTF6, INTR6)**

The INTF6 and INTR6 registers are 8-bit registers that specify detection of the falling and rising edges of the external interrupt pin (INTP9).

These registers can be read or written in 8-bit or 1-bit units.

Reset sets these registers to 00H.

**Caution** When the function is changed from the external interrupt function (alternate function) to the port function, an edge may be detected. Therefore, clear the INTF66 and INTR66 bits to 00, and then set the port mode.

After reset: 00H    R/W    Address: INTF6 FFFFFFFC0CH, INTR6 FFFFFFFC2CH

7	6	5	4	3	2	1	0
INTF6	0	INTF66	0	0	0	0	0
		└──┬──┘					
		INTP9					
7	6	5	4	3	2	1	0
INTR6	0	INTR66	0	0	0	0	0
		└──┬──┘					
		INTP9					

**Remark** For how to specify a valid edge, see **Table 24-7**.

**Table 24-7. Valid Edge Specification**

INTF66	INTR66	Valid Edge Specification
0	0	No edge detected
0	1	Rising edge
1	0	Falling edge
1	1	Both rising and falling edges

**Caution** Be sure to clear the INTF66 and INTR66 bits to 00 when these registers are not used as INTP9 pin.



**(6) External interrupt falling, rising edge specification register 8 (INTF8, INTR8)**

The INTF8 and INTR8 registers are 8-bit registers that specify detection of the falling and rising edges of the external interrupt pin (INTP8).

These registers can be read or written in 8-bit or 1-bit units.

Reset sets these registers to 00H.

- Cautions**
1. When the function is changed from the external interrupt function (alternate function) to the port function, an edge may be detected. Therefore, clear the INTF80 and INTR80 bits to 00, and then set the port mode.
  2. The INTP8 pin and RXDA3 pin are alternate-function pins. When using the pin as the RXDA3 pin, disable edge detection for the INTP8 alternate-function pin (clear the INTF8.INTF80 bit and the INTR8.INTR80 bit to 0). When using the pin as the INTP8 pin, stop UARTA3 reception (clear the UA3CTL0.UA3RXE bit to 0).
  3. Be sure to set bits 1 to 7 of the INTF8 and INTR8 registers to 0.

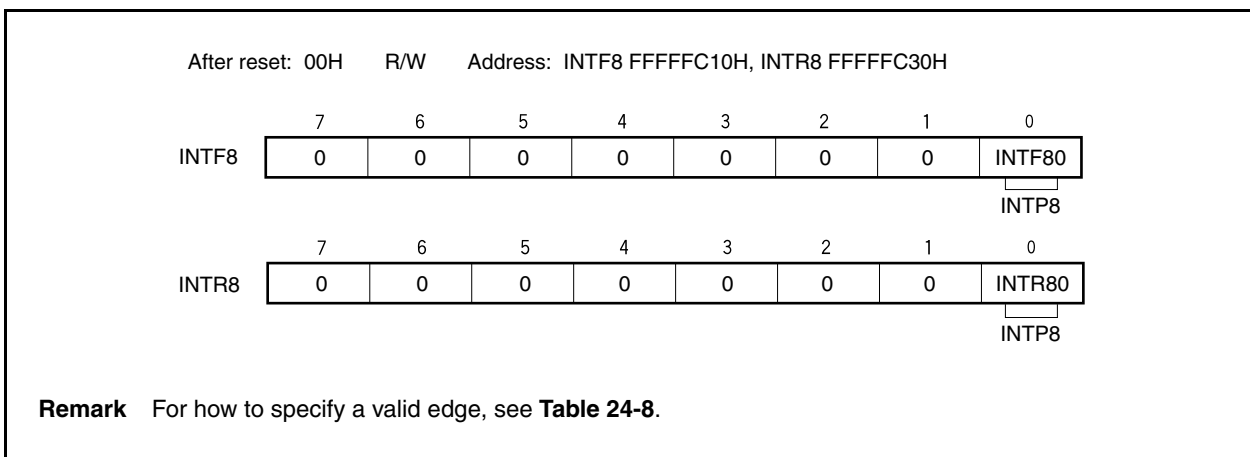

**Table 24-8. Valid Edge Specification**

INTF80	INTR80	Valid Edge Specification
0	0	No edge detected
0	1	Rising edge
1	0	Falling edge
1	1	Both rising and falling edges

**Caution** Be sure to clear the INTF80 and INTR80 bits to 00 when these registers are not used as INTP8 pin.

**(7) External interrupt falling, rising edge specification register 9 (INTF9, INTR9)**

The INTF9H and INTR9H registers are 8-bit registers that specify detection of the falling and rising edges of the external interrupt pins (INTP4 to INTP6, INTP8).

These registers can be read or written in 8-bit or 1-bit units.

Reset sets these registers to 0000H.

**Caution** When the function is changed from the external interrupt function (alternate function) to the port function, an edge may be detected. Therefore, clear the INTF9n and INTR9n bits to 0, and then set the port mode.

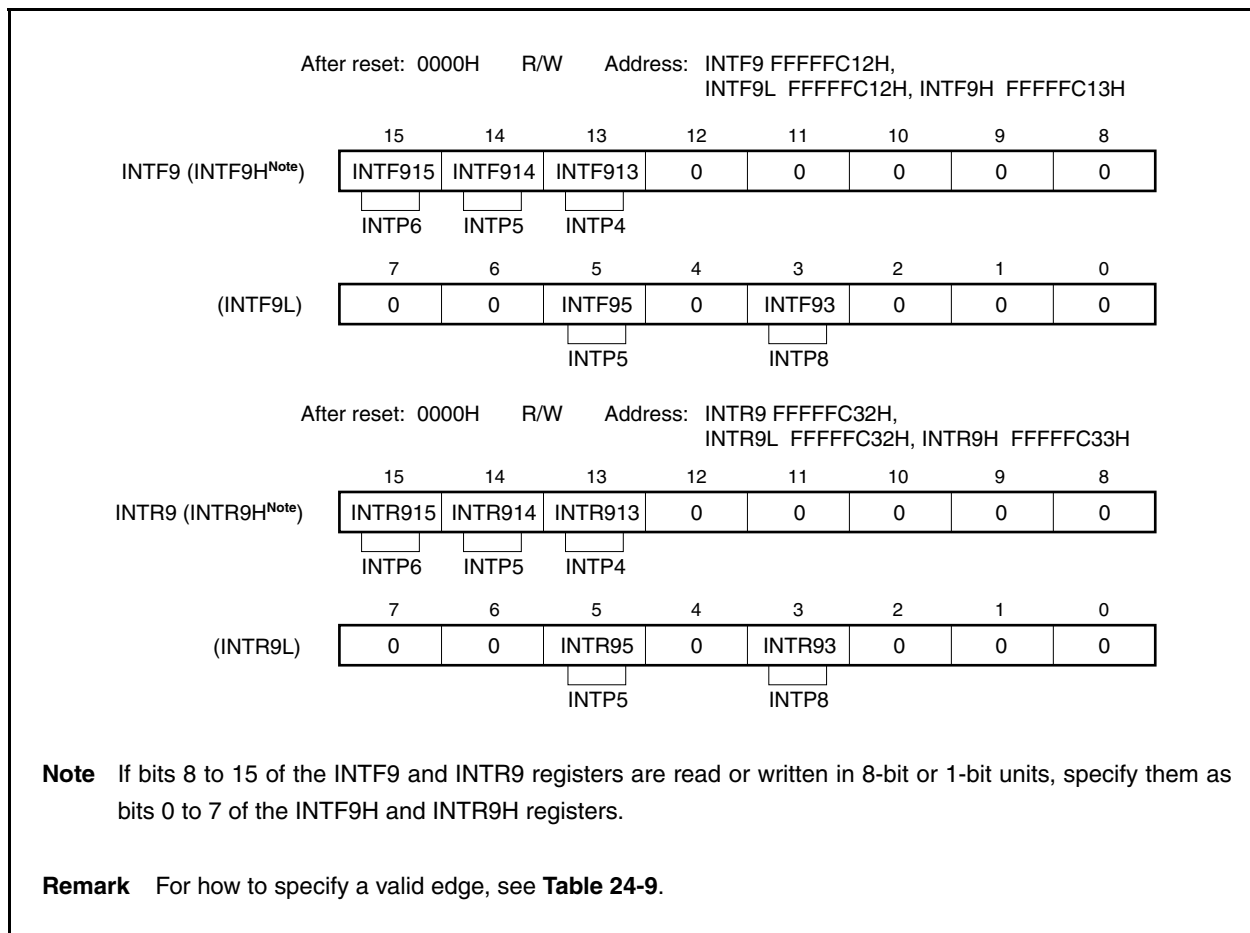

**Table 24-9. Valid Edge Specification**

INTF9n	INTR9n	Valid Edge Specification (n = 3, 5, 13 to 15)
0	0	No edge detected
0	1	Rising edge
1	0	Falling edge
1	1	Both rising and falling edges

**Caution** Be sure to clear the INTF9n and INTR9n bits to 00 when these registers are not used as any of pins INTP4 to INTP6, and INTP8.

**Remark** n = 3, 5, 13 to 15: Control of INTP4 to INTP6, and INTP8 pins

**(8) External interrupt falling/rising edge specification register 15 (INTF15, INTR15) (V850E/SK3-H only)**

The INTF15 and INTR15 registers are 8-bit registers that specify detection of the falling and rising edges of the external interrupt pin (INTP6, INTP9).

These registers can be read or written in 8-bit or 1-bit units.

Reset sets these registers to 00H.

- Cautions**
1. When the function is changed from the external interrupt function (alternate function) to the port function, an edge may be detected. Therefore, clear the INTF15n and INTR15n bits to 00, and then set the port mode.
  2. Be sure to set bits 0, 1, and 4 to 7 of the INTF15 and INTR15 registers to 0.

After reset: 00H    R/W    Address: INTF15 FFFFFC1EH<sup>Note</sup>, INTR15 FFFFFC3EH<sup>Note</sup>

	7	6	5	4	3	2	1	0
INTF15	0	0	0	0	INTF153	INTF152	0	0
					INTP6	INTP9		

	7	6	5	4	3	2	1	0
INTR15	0	0	0	0	INTR153	INTR152	0	0
					INTP6	INTP9		

**Note** V850E/SK3-H only.

**Remark** For how to specify a valid edge, see **Table 24-10**.

**Table 24-10. Valid Edge Specification**

INTF15n	INTR15n	Valid Edge Specification
0	0	No edge detected
0	1	Rising edge
1	0	Falling edge
1	1	Both rising and falling edges

**Caution** Be sure to clear the INTF15n and INTR15n bits to 00 when these registers are not used as INTP6 or INTP9 pin.

**Remark** n = 2, 3: Control of INTP6 and INTP9 pins

**(9) Noise elimination control register (NFC)**

Digital noise elimination can be selected for the INTP3 pin. The noise elimination settings are performed using the NFC register.

When digital noise elimination is selected, the sampling clock for digital sampling can be selected from among  $f_{XP}/64$ ,  $f_{XP}/128$ ,  $f_{XP}/256$ ,  $f_{XP}/512$ ,  $f_{XP}/1,024$ , and  $f_{XT}$ . Sampling is performed three times.

When digital noise elimination is selected, if the clock that performs sampling in the standby mode is stopped, then the INTP3 interrupt request signal cannot be used for releasing the standby mode. When  $f_{XT}$  is used as the sampling clock, the INTP3 interrupt request signal can be used for releasing either the subclock operating mode or the IDLE1/IDLE2/STOP/sub-IDLE mode.

This register can be read or written in 8-bit units.

Reset sets this register to 00H.

**Caution** After the sampling clock has been changed, it takes 3 sampling clocks to initialize the digital noise eliminator. Therefore, if an INTP3 valid edge is input within these 3 sampling clocks after the sampling clock has been changed, an interrupt request signal may be generated. Therefore, be careful about the following points when using the interrupt and DMA functions.

- When using the interrupt function, after the 3 sampling clocks have elapsed, enable interrupts after the interrupt request flag (PIC3.PIF3 bit) has been cleared.
- When using the DMA function (started by INTP3), enable DMA after 3 sampling clocks have elapsed.

After reset: 00H R/W Address: FFFFF318H

	7	6	5	4	3	2	1	0
NFC	NFEN	0	0	0	0	NFC2	NFC1	NFC0

NFEN	Settings of INTP3 pin noise elimination
0	Analog noise elimination (60 ns (TYP.))
1	Digital noise elimination

NFC2	NFC1	NFC0	Digital sampling clock
0	0	0	$f_{XP}/64$
0	0	1	$f_{XP}/128$
0	1	0	$f_{XP}/256$
0	1	1	$f_{XP}/512$
1	0	0	$f_{XP}/1,024$
1	0	1	$f_{XT}$ (subclock)
Other than above			Setting prohibited

**Caution** Be sure to set bits 3 to 6 to "0".

- Remarks**
1. Since sampling is performed three times, the reliably eliminated noise width is 2 sampling clocks.
  2. In the case of noise with a width smaller than 2 sampling clocks, an interrupt request signal is generated if noise synchronized with the sampling clock is input.

## 24.7 Interrupt Acknowledge Time of CPU

Except the following cases, the interrupt acknowledge time of the CPU is 4 clocks minimum. To input interrupt request signals successively, input the next interrupt request signal at least 4 clocks after the preceding interrupt.

- In IDLE1/IDLE2/STOP mode
- When the external bus is accessed
- When interrupt request non-sampling instructions are successively executed (see **24.8 Periods in Which Interrupts Are Not Acknowledged by CPU.**)
- When the interrupt control register is accessed
- When an on-chip peripheral I/O register is accessed
- When a programmable peripheral I/O register is accessed

Figure 24-15. Pipeline Operation at Interrupt Request Signal Acknowledgment (Outline)

(1) Minimum interrupt response time

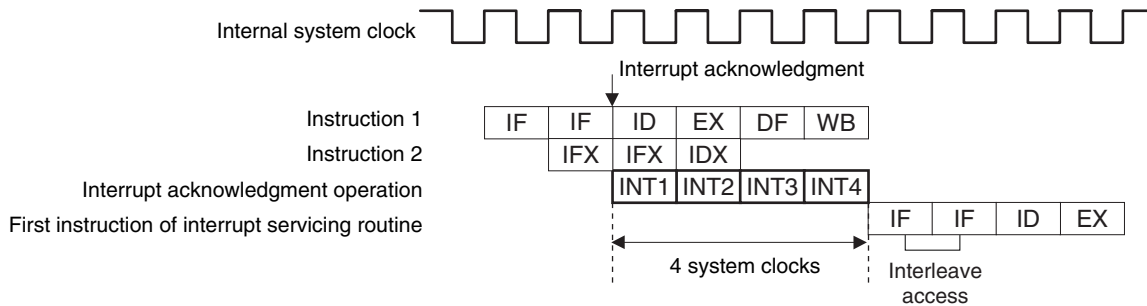

(2) Maximum interrupt response time

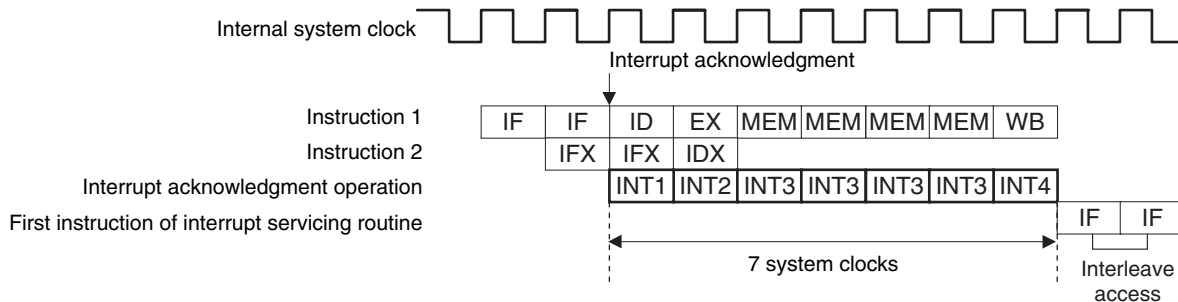

Remarks 1. INT1 to INT4: Interrupt acknowledgment processing

- IFX: Invalid instruction fetch
- IDX: Invalid instruction decode

2. If the same interrupt request signal is generated while an interrupt of four cycles is being acknowledged, the new interrupt request signal is discarded. The next interrupt request signal from the same source is registered four cycles later.

	Interrupt response time (internal system clock)		Condition
	Internal interrupt	External interrupt	
Minimum	4	4 + Analog delay time	The following cases are exceptions. <ul style="list-style-type: none"> <li>• In IDLE1/IDLE2/STOP mode</li> <li>• External bus access</li> <li>• Two or more interrupt request non-sample instructions are executed in succession</li> <li>• Access to interrupt control register</li> <li>• Access to on-chip peripheral I/O register</li> <li>• Access to programmable peripheral I/O register</li> </ul>
Maximum	7	7 + Analog delay time	

## 24.8 Periods in Which Interrupts Are Not Acknowledged by CPU

An interrupt is acknowledged by the CPU while an instruction is being executed. However, no interrupt will be acknowledged between an interrupt request non-sample instruction and the next instruction (interrupt is held pending).

The interrupt request non-sample instructions are as follows.

- EI instruction
- DI instruction
- LDSR reg2, 0x5 instruction (for PSW)
- The store instruction for the PRCMD register
- The store, SET1, NOT1, or CLR1 instructions for the following registers.
  - Interrupt-related registers:  
Interrupt control register (xxICn), interrupt mask registers 0 to 6, 7L (IMR0 to IMR6, IMR7L)
  - Power save control register (PSC)
  - On-chip debug mode register (OCDM)

**Remark** xx: Identification name of each peripheral unit (see **Table 24-2 Interrupt Control Register (xxICn)**)

n: Peripheral unit number (see **Table 24-2 Interrupt Control Register (xxICn)**).

## 24.9 Cautions

### (1) NMI pin

The NMI pin alternately functions as the P02 pin. It functions as the P02 pin after reset. To enable the NMI pin, validate the NMI pin with the PMC0 register. The initial setting of the NMI pin is “No edge detected”. Select the NMI pin valid edge using the INTF0 and INTRO registers.

### (2) Interrupt control register (xxICn)

When manipulating the xxICn.xxMKn bit while interrupt requests may occur (including the state in which interrupts are disabled (DI)), be sure to use a bit manipulation instruction or use the IMRm.xxMKn or IMR7L.xxMKn bit (m = 0 to 6).

### (3) In-service priority register (ISPR)

If an interrupt is acknowledged while the ISPR register is being read in the interrupt enabled (EI) status, the value of the ISPR register after the bits of the register have been set by acknowledging the interrupt may be read. To accurately read the value of the ISPR register before an interrupt is acknowledged, read the register while interrupts are disabled (DI).

### (4) Switching DMA transfer start factors

In the V850E/SJ3-H and V850E/SK3-H, because the INTP8 signal and the INTTM2EQ0 signal of the DMA transfer start factors are used alternately, they cannot be used at the same time. When the INTP8 signal is used as a DMA transfer start factor, set the DTFROB0 bit in option byte 0000007AH to 0 (refer to **CHAPTER 33 OPTION BYTE FUNCTION**). In this case, the INTTM2EQ0 signal cannot be used as the DMA transfer start factors.

**Remark** For details, see **Table 22-1 DMA Transfer Start Factors**.

## CHAPTER 25 KEY INTERRUPT FUNCTION

### 25.1 Function

A key interrupt request signal (INTKR) can be generated by inputting a falling edge to the eight key input pins (KR0 to KR7) by setting the KRM register.

**Table 25-1. Assignment of Key Return Detection Pins**

Flag	Pin Description
KRM0	Controls KR0 signal in 1-bit units
KRM1	Controls KR1 signal in 1-bit units
KRM2	Controls KR2 signal in 1-bit units
KRM3	Controls KR3 signal in 1-bit units
KRM4	Controls KR4 signal in 1-bit units
KRM5	Controls KR5 signal in 1-bit units
KRM6	Controls KR6 signal in 1-bit units
KRM7	Controls KR7 signal in 1-bit units

**Figure 25-1. Key Return Block Diagram**

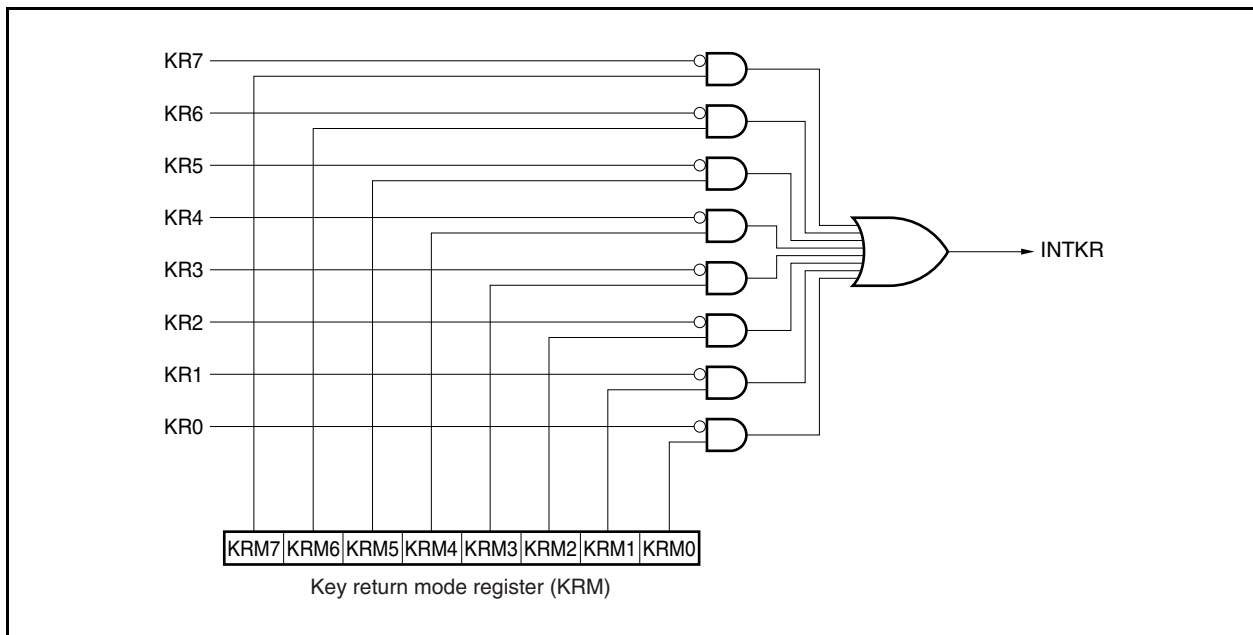



## 25.2 Register

### (1) Key return mode register (KRM)

The KRM register controls the KRM0 to KRM7 bits using the KR0 to KR7 signals.

This register can be read or written in 8-bit or 1-bit units.

Reset sets this register to 00H.

After reset: 00H		R/W	Address: FFFFF300H					
	7	6	5	4	3	2	1	0
KRM	KRM7	KRM6	KRM5	KRM4	KRM3	KRM2	KRM1	KRM0
KRMn	Control of key return mode							
0	Does not detect key return signal							
1	Detects key return signal							

**Caution** Rewrite the KRM register after once clearing the KRM register to 00H.

**Remark** For the alternate-function pin settings, see **Table 4-25 Using Port Pin as Alternate Function Pin**.

## 25.3 Cautions

### (1) Low level input to the KR0 to KR7 pins

If a low level is input to any of the KR0 to KR7 pins, the INTKR signal is not generated even if the falling edge of another pin is input.

### (2) Use of the KR7 and RXDA1 pins at the same time

The KR7 and RXDA1 pins must not be used at the same time. In the V850E/SK3-H, the KR7 and RXDA1 pins are assigned to two ports each, and cannot be used at the same time at different ports.

To use the KR7 pin, set the UA1CTL0.UA1RXE bit to 0 (it is recommended to set the PFC91 bit to 1 and PFCE91 bit to 0 when using the KR7 pin at P91). To use the RXDA1 pin, set the KRM.KRM7 bit of the KR7 pin to 0.

**(3) Use of the KRn and TIQ0m pins at the same time**

The KRn and TIQ0m pins must not be used at the same time ( $n = 0$  to  $3$ ,  $m = 0$  to  $3$ ). The KR2 and TIQ03 pins and the KR3 and TIQ00 pins are assigned to two ports each, and cannot be used at the same time at different ports. Settings for using the KRn or TIQ0m pin are shown below.

Pin Name	When Using Pin as TIQ0m Pin	When Using Pin as KRn Pin
KR0/TIQ01	KRM.KRM0 bit = 0	TQ0IOC1.TQ0IS3, TQ0IS2 bits = 00
KR1/TIQ02	KRM.KRM1 bit = 0	TQ0IOC1.TQ0IS5, TQ0IS4 bits = 00
KR2/TIQ03	KRM.KRM2 bit = 0	TQ0IOC1.TQ0IS7, TQ0IS6 bits = 00
KR3/TIQ00	KRM.KRM3 bit = 0	TQ0IOC1.TQ0IS1, TQ0IS0 bits = 00 TQ0IOC2.TQ0EES1, TQ0EES0 bits = 00 TQ0IOC2.TQ0ETS1, TQ0ETS0 bits = 00

**(4) Notes on setting the KRM register**

If the KRM register is changed, an interrupt request signal (INTKR) may be generated. To prevent this, change the KRM register after disabling interrupts (DI) or masking, then clear the interrupt request flag (KRIC.KRIF bit) to 0, and enable interrupts (EI) or clear the mask.

**(5) Switching between port mode and alternate-function mode**

To use the key interrupt function, be sure to set the port pin to the key return pin and then enable the operation with the KRM register. To switch from the key return pin to the port pin, disable the operation with the KRM register and then set the port pin.

**(6) Switching DMA transfer start factor**

In the V850E/SJ3-H and V850E/SK3-H, the INTKR signal and the INTTM1EQ0 signal, both being the DMA transfer start factors, are alternate functions of the same pin, and they cannot be used at the same time. To use the INTKR signal as the DMA transfer start factor, set the DTFROB0 bit in the option byte area 0000007AH to 0 (refer to **CHAPTER 33 OPTION BYTE FUNCTION**). In this case, the INTTM1EQ0 signal cannot be used as the DMA transfer start factor.

**Remark** For details, see **Table 22-1 DMA Transfer Start Factors**.

## CHAPTER 26 STANDBY FUNCTION

### 26.1 Overview

The power consumption of the system can be effectively reduced by using the standby modes in combination and selecting the appropriate mode for the application. The available standby modes are listed in Table 26-1.

**Table 26-1. Standby Modes**

Mode	Functional Outline
HALT mode	Mode in which only the operating clock ( $f_{CPU}$ ) of the CPU is stopped
IDLE1 mode	Mode in which all the operations of the internal circuits except the oscillator, PLL <sup>Note</sup> , SSCG <sup>Note</sup> , and flash memory are stopped
IDLE2 mode	Mode in which all the operations of the internal circuits except the oscillator are stopped
STOP mode	Mode in which all the operations of the internal circuits except the subclock oscillator and internal oscillator are stopped
Subclock operation mode	Mode in which the subclock is used as the internal system clock
Sub-IDLE mode	Mode in which all the operations of the internal circuits except the oscillator are stopped, in the subclock operation mode

**Note** The PLL and SSCG hold the previous operating status.

## 26.2 Registers

### (1) Power save control register (PSC)

The PSC register is an 8-bit register that controls the standby function. The STP bit of this register is used to specify the standby mode. This register is a special register that can be written only by the special sequence combinations (see 3.4.8 Special registers).

This register can be read or written in 8-bit or 1-bit units.

Reset sets this register to 00H.

After reset: 00H    R/W    Address: FFFFF1FEH

	7	<6>	<5>	<4>	3	2	<1>	0
PSC	0	NMI1M	NMI0M	INTM	0	0	STP	0

NMI1M	Standby mode release control upon occurrence of INTWDT2 signal
0	Standby mode release by INTWDT2 signal enabled
1	Standby mode release by INTWDT2 signal disabled

NMI0M	Standby mode release control by NMI pin input
0	Standby mode release by NMI pin input enabled
1	Standby mode release by NMI pin input disabled

INTM	Standby mode release control via maskable interrupt request signal
0	Standby mode release by maskable interrupt request signal enabled
1	Standby mode release by maskable interrupt request signal disabled

STP	Standby mode <sup>Note</sup> setting
0	Normal mode
1	Standby mode

**Note** Standby mode set by STP bit: IDLE1, IDLE2, STOP, or sub-IDLE mode

- Cautions**
1. Before setting the IDLE1, IDLE2, STOP, or sub-IDLE mode, set the PSMR.PSM1 and PSMR.PSM0 bits and then set the STP bit.
  2. Settings of the NMI1M, NMI0M, and INTM bits are invalid when HALT mode is released.
  3. If the NMI1M, NMI0M, or INTM bit is set to 1 at the same time the STP bit is set to 1, the setting of NMI1M, NMI0M, or INTM bit becomes invalid. If there is an unmasked interrupt request signal being held pending when the IDLE1/IDLE2/STOP mode is set, set the bit corresponding to the interrupt request signal (NMI1M, NMI0M, or INTM) to 1, and then set the STP bit to 1.
  4. Be sure to set bits 0, 2, 3, and 7 to "0".

**(2) Power save mode register (PSMR)**

The PSMR register is an 8-bit register that controls the operation status in the power save mode.

This register can be read or written in 8-bit or 1-bit units.

Reset sets this register to 00H.

After reset: 00H    R/W    Address: FFFF820H

	7	6	5	4	3	2	<1>	<0>
PSMR	0	0	0	0	0	0	PSM1	PSM0

PSM1	PSM0	Specification of operation in software standby mode
0	0	IDLE1, sub-IDLE modes
0	1	STOP, sub-IDLE modes
1	0	IDLE2, sub-IDLE modes
1	1	STOP mode

**Cautions 1. Be sure to clear bits 2 to 7 to “0”.**

**2. The PSM0 and PSM1 bits are valid only when the PSC.STP bit is 1.**

**Remark** IDLE1: In this mode, all operations except the oscillator operation and some other circuits (flash memory, PLL, and SSCG) are stopped.  
After the IDLE1 mode is released, the normal operation mode is restored without needing to secure the oscillation stabilization time, like the HALT mode.

IDLE2: In this mode, all operations except the oscillator operation are stopped.  
After the IDLE2 mode is released, the normal operation mode is restored following the lapse of the setup time specified by the OSTS register (flash memory, PLL, and SSCG).

STOP: In this mode, all operations except the subclock oscillator operation are stopped.  
After the STOP mode is released, the normal operation mode is restored following the lapse of the oscillation stabilization time specified by the OSTS register.

Sub-IDLE: In this mode, all other operations are halted except for the oscillator. After the IDLE mode has been released by the interrupt request signal, the subclock operation mode will be restored after 12 cycles of the subclock have been secured.

**(3) Oscillation stabilization time select register (OSTS)**

The wait time until the main oscillation stabilizes after the STOP mode is released or the wait time until the on-chip flash memory stabilizes after the IDLE2 mode is released is controlled by the OSTS register.

The OSTS register can be read or written 8-bit units.

Reset sets this register to 06H.

(1/2)

After reset: 06H R/W Address: FFFFF6C0H

	7	6	5	4	3	2	1	0
OSTS	0	0	0	0	0	OSTS2	OSTS1	OSTS0

OSTS2	OSTS1	OSTS0	Selection of oscillation stabilization time/setup time <sup>Note</sup>	fx	
				4 MHz	5 MHz
				0	0
0	0	1	$2^{11}/f_x$	0.512 ms	0.410 ms
0	1	0	$2^{12}/f_x$	1.024 ms	0.819 ms
0	1	1	$2^{13}/f_x$	2.048 ms	1.638 ms
1	0	0	$2^{14}/f_x$	4.096 ms	3.277 ms
1	0	1	$2^{15}/f_x$	8.192 ms	6.554 ms
1	1	0	$2^{16}/f_x$	16.38 ms	13.107 ms
1	1	1	Setting prohibited		

**Note** The oscillation stabilization time and setup time are required when the STOP mode and IDLE2 mode are released, respectively.

**Remark** fx: Main oscillation clock frequency

**Cautions** 1. The wait time following release of the STOP mode does not include the time until the clock oscillation starts (“a” in the figure below) following release of the STOP mode, regardless of whether the STOP mode is released by reset or the occurrence of an interrupt request signal.

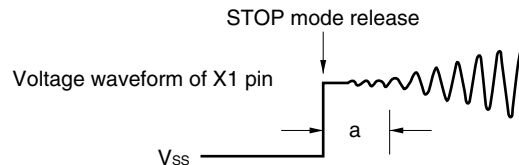

2. Be sure to clear bits 3 to 7 to “0”.
3. The oscillation stabilization time following reset release is  $2^{16}/f_x$  (because the initial value of the OSTS register = 06H).

- Cautions**
4. In clock mode 1, if the system shifts to IDLE2 mode while the PLL is operating, be sure to set a setup time of at least 800  $\mu\text{s}$  to be inserted after IDLE2 mode is released. If the PLL is stopped, set a setup time of at least 350  $\mu\text{s}$  to be inserted after IDLE2 mode is released.
  5. In clock mode 1, if the system shifts to STOP mode while the PLL is operating, be sure to set an oscillation stabilization time of at least 1 ms to be inserted after STOP mode is released.
  6. In clock modes 2, 3, and 4, if the system shifts to IDLE2 mode while the SSCG is operating, be sure to set a setup time of at least 1 ms to be inserted after IDLE2 mode is released. If the SSCG is stopped, set a setup time of at least 800  $\mu\text{s}$  to be inserted after IDLE2 mode is released.
  7. In clock modes 2, 3, and 4, if the system shifts to STOP mode while the SSCG is operating, be sure to set an oscillation stabilization time of at least 2 ms to be inserted after STOP mode is released.

## 26.3 HALT Mode

### 26.3.1 Setting and operation status

The HALT mode is set when a dedicated instruction (HALT) is executed in the normal operation mode.

In the HALT mode, the clock oscillator continues operating. Only clock supply to the CPU is stopped; clock supply to the other on-chip peripheral functions continues.

As a result, program execution is stopped, and the internal RAM and expanded internal RAM retain the contents before the HALT mode was set. The on-chip peripheral functions that are independent of instruction processing by the CPU continue operating.

Table 26-3 shows the operating status in the HALT mode.

The average current consumption of the system can be reduced by using the HALT mode in combination with the normal operation mode for intermittent operation.

**Cautions 1. Insert five or more NOP instructions after the HALT instruction.**

- 2. If the HALT instruction is executed while an unmasked interrupt request signal is being held pending, the status shifts to HALT mode, but the HALT mode is then released immediately by the pending interrupt request.**

### 26.3.2 Releasing HALT mode

The HALT mode is released by a non-maskable interrupt request signal (NMI pin input, INTWDT2 signal), unmasked external interrupt request signal (INTP0 to INTP9 pin input), unmasked internal interrupt request signal from a peripheral function operable in the HALT mode, or reset signal (RESET pin input, reset signal (WDT2RES) generation by overflow of watchdog timer 2, reset signal (LVIRES) generation by low voltage detector (LVI), or reset signal (CLMRES) generation by clock monitor (CLM)).

After the HALT mode has been released, the normal operation mode is restored.

**(1) Releasing HALT mode by non-maskable interrupt request signal or unmasked maskable interrupt request signal**

The HALT mode is released by a non-maskable interrupt request signal or an unmasked maskable interrupt request signal, regardless of the priority of the interrupt request signal. If the HALT mode is set in an interrupt servicing routine, however, an interrupt request signal that is issued later is serviced as follows.

- (a) If an interrupt request signal with a priority lower than that of the interrupt request currently being serviced is issued, the HALT mode is released, but that interrupt request signal is not acknowledged. The interrupt request signal itself is retained.
- (b) If an interrupt request signal with a priority higher than that of the interrupt request currently being serviced is issued (including a non-maskable interrupt request signal), the HALT mode is released and that interrupt request signal is acknowledged.

**Table 26-2. Operation After Releasing HALT Mode by Interrupt Request Signal**

Release Source	Interrupt Enabled (EI) Status	Interrupt Disabled (DI) Status
Non-maskable interrupt request signal	Execution branches to the handler address.	
Maskable interrupt request signal	Execution branches to the handler address or the next instruction is executed.	The next instruction is executed.



**(2) Releasing HALT mode by reset**

The same operation as the normal reset operation is performed.

**Table 26-3. Operating Status in HALT Mode**

Setting of HALT Mode Item		Operating Status	
		When Subclock Is Not Used	When Subclock Is Used
Main clock oscillator		Oscillation enabled	
Subclock oscillator		–	Oscillation enabled
Internal oscillator		Oscillation enabled	
PLL		Operable	
SSCG		Operable	
CPU		Stops operation	
DMA		Operable	
Interrupt controller		Operable	
ROM correction		Stops operation	
Timer P (TMP0 to TMP8)		Operable	
Timer Q (TMQ0)		Operable	
Timer M	TMM0	Operable when a clock other than $f_{XT}$ is selected as the count clock	Operable
	TMM1	Operable	
	TMM2	Operable	
Watch timer		Operable when $f_{BRG}$ is selected as the count clock	Operable
Real-time counter (RTC)		Operable when $f_{BRG}$ is selected as the count clock	Operable
Watchdog timer 2		Operable when a clock other than $f_{XT}$ is selected as the count clock	Operable
Serial interface	CSIB0 to CSIB5	Operable	
	CSIE0 <sup>Note 1</sup> , CSIE1 <sup>Note 1</sup>	Operable	
	I <sup>2</sup> C00 to I <sup>2</sup> C03, I <sup>2</sup> C04 <sup>Note 1</sup> , I <sup>2</sup> C05 <sup>Note 1</sup>	Operable	
	UARTA0 to UARTA5	Operable	
	UARTB0, UARTB1	Operable	
CAN controller <sup>Note 2</sup>		Operable	
IEBus controller		Operable	
A/D converter		Operable	
D/A converter		Operable	
Real-time output function (RTO)		Operable	
Key interrupt function (KR)		Operable	
CRC arithmetic circuit		Operable (in the status in which data is not input to CRCIN to stop the CPU)	
External bus interface		See 2.3 Pin States.	
Port function		Retains status before HALT mode was set	
Internal data		The CPU registers, statuses, data, and all other internal data such as the contents of the internal RAM and expanded internal RAM are retained as they were before the HALT mode was set.	

&lt;R&gt;

&lt;R&gt;

&lt;R&gt;

**Notes** 1. Not available in the  $\mu$ PD70F3931 (V850E/SJ3-H), 70F3932 (V850E/SJ3-H), and 70F3933 (V850E/SJ3-H)  
 2. CAN controller versions only

## 26.4 IDLE1 Mode

### 26.4.1 Setting and operation status

The IDLE1 mode is set by clearing the PSMR.PSM1 and PSMR.PSM0 bits to 00 and setting the PSC.STP bit to 1 in the normal operation mode.

In the IDLE1 mode, the clock oscillator, PLL, SSCG, and flash memory continue operating but the main clock ( $f_{xx}$ ) and peripheral clock ( $f_{xP}$ ) stop.

As a result, program execution stops and the contents of the internal RAM and expanded internal RAM before the IDLE1 mode was set are retained. The CPU and other on-chip peripheral functions that operate on the main clock ( $f_{xx}$ ) or peripheral clock ( $f_{xP}$ ) stop operating. However, the on-chip peripheral functions that can operate on the main oscillation clock ( $f_x$ ), subclock ( $f_{xT}$ ), internal oscillation clock ( $f_R$ ) or an external clock continue operating.

Table 26-5 shows the operating status in the IDLE1 mode.

The IDLE1 mode can reduce the power consumption more than the HALT mode because it stops the operation of the on-chip peripheral functions. The main clock oscillator does not stop, so the normal operation mode can be restored without waiting for the oscillation stabilization time after the IDLE1 mode has been released, in the same manner as when the HALT mode is released.

- Cautions**
1. Insert five or more NOP instructions after the instruction that stores data in the PSC register to set the IDLE1 mode.
  2. If the IDLE1 mode is set while an unmasked interrupt request signal is being held pending, the IDLE1 mode is released immediately by the pending interrupt request.

### 26.4.2 Releasing IDLE1 mode

The IDLE1 mode is released by a non-maskable interrupt request signal (NMI pin input, INTWDT2 signal), unmasked external interrupt request signal (INTP0 to INTP9 pin input), unmasked internal interrupt request signal from a peripheral function operable in the IDLE1 mode, or reset signal ( $\overline{\text{RESET}}$  pin input, reset signal (WDT2RES) generation by overflow of watchdog timer 2, reset signal (LVIRESET) generation by low voltage detector (LVI), or reset signal (CLMRES) generation by clock monitor (CLM)).

After the IDLE1 mode has been released, the normal operation mode is restored.

#### (1) Releasing IDLE1 mode by non-maskable interrupt request signal or unmasked maskable interrupt request signal

The IDLE1 mode is released by a non-maskable interrupt request signal or an unmasked maskable interrupt request signal, regardless of the priority of the interrupt request signal. If the IDLE1 mode is set in an interrupt servicing routine, however, an interrupt request signal that is issued later is processed as follows.

- (a) If an interrupt request signal with a priority lower than that of the interrupt request currently being serviced is issued, the IDLE1 mode is released, but that interrupt request signal is not acknowledged. The interrupt request signal itself is retained.
- (b) If an interrupt request signal with a priority higher than that of the interrupt request currently being serviced is issued (including a non-maskable interrupt request signal), the IDLE1 mode is released and that interrupt request signal is acknowledged.

**Caution** An interrupt request signal that is disabled by setting the PSC.NMI1M, PSC.NMI0M, and PSC.INTM bits to 1 becomes invalid and IDLE1 mode is not released.

**Table 26-4. Operation After Releasing IDLE1 Mode by Interrupt Request Signal**

Release Source	Interrupt Enabled (EI) Status	Interrupt Disabled (DI) Status
Non-maskable interrupt request signal	Execution branches to the handler address.	
Maskable interrupt request signal	Execution branches to the handler address or the next instruction is executed.	The next instruction is executed.

**(2) Releasing IDLE1 mode by reset**

The same operation as the normal reset operation is performed.

Table 26-5. Operating Status in IDLE1 Mode

Setting of IDLE1 Mode		Operating Status	
		When Subclock Is Not Used	When Subclock Is Used
Main clock oscillator		Oscillation enabled	
Subclock oscillator		–	Oscillation enabled
Internal oscillator		Oscillation enabled	
PLL		Operable	
SSCG		Operable	
CPU		Stops operation	
DMA		Stops operation	
Interrupt controller		Stops operation (but standby mode release is possible)	
ROM correction		Stops operation	
Timer P (TMP0 to TMP8)		Stops operation	
Timer Q (TMQ0)		Stops operation	
Timer M	TMM0	Operable when INTWT (when watch timer is operating) or $f_{R/8}$ is selected as the count clock	Operable when INTWT (when watch timer is operating) $f_{R/8}$ , or $f_{XT}$ is selected as the count clock
	TMM1	Operable when $f_{BRG}$ , $f_{R/8}$ , or INTTM0EQ0 (when TMM0 is operating) is selected as the count clock.	
	TMM2	Operable when $f_{BRG}$ , $f_{R/8}$ , or INTTM1EQ0 (when TMM1 is operating) is selected as the count clock.	
Watch timer		Operable when $f_{BRG}$ is selected as the count clock	Operable
Real-time counter (RTC)		Operable when $f_{BRG}$ is selected as the count clock	Operable
Watchdog timer 2		Operable when $f_{R/8}$ is selected as the count clock	Operable when $f_{R/8}$ or $f_{XT}$ is selected as the count clock
<R> <R>	Serial interface	CSIB0 to CSIB5	Operable when the $\overline{SCKBn}$ input clock is selected as the transfer clock ( $n = 0$ to 5)
		CSIE0 <sup>Note 1</sup> , CSIE1 <sup>Note 1</sup>	Stops operation
		I <sup>2</sup> C00 to I <sup>2</sup> C03, I <sup>2</sup> C04 <sup>Note 1</sup> , I <sup>2</sup> C05 <sup>Note 1</sup>	Stops operation
		UARTA0 to UARTA5	Stops operation (but UARTA0 is operable when the ASCKA0 input clock is selected)
		UARTB0, UARTB1	Stops operation
CAN controller <sup>Note 2</sup>		Stops operation	
IEBus controller		Stops operation	
A/D converter		Holds operation (conversion result held) <sup>Note 3</sup>	
D/A converter		Holds operation (output held <sup>Note 3</sup> )	
Real-time output function (RTO)		Stops operation (output held)	
Key interrupt function (KR)		Operable	
CRC arithmetic circuit		Stops operation	
External bus interface		See 2.3 Pin States.	
Port function		Retains status before IDLE1 mode was set	
Internal data		The CPU registers, statuses, data, and all other internal data such as the contents of the internal RAM or expanded internal RAM are retained as they were before the IDLE1 mode was set.	

- <R> **Notes**
1. Not available in the  $\mu$ PD70F3931 (V850E/SJ3-H), 70F3932 (V850E/SJ3-H), and 70F3933 (V850E/SJ3-H)
  2. CAN controller versions only
  3. To realize low power consumption, stop the A/D converter and D/A converter before shifting to the IDLE1 mode.

## 26.5 IDLE2 Mode

### 26.5.1 Setting and operation status

The IDLE2 mode is set by setting the PSMR.PSM1 and PSMR.PSM0 bits to 10 and setting the PSC.STP bit to 1 in the normal operation mode.

In the IDLE2 mode, the clock oscillator continues operation but supply of the main clock ( $f_{xx}$ ) and peripheral clock ( $f_{xP}$ ) to the PLL and SSCG stops. The flash memory stops operating.

As a result, program execution stops and the contents of the internal RAM and expanded internal RAM before the IDLE2 mode was set are retained. The CPU and other on-chip peripheral functions that operate on the main clock ( $f_{xx}$ ) or peripheral clock ( $f_{xP}$ ) stop operating. However, the on-chip peripheral functions that can operate on the main clock ( $f_x$ ) oscillation, subclock ( $f_{xT}$ ) or internal oscillation clock ( $f_R$ ) continue operating.

Table 26-7 shows the operating status in the IDLE2 mode.

The IDLE2 mode can reduce the power consumption more than the IDLE1 mode because it stops the operations of the on-chip peripheral functions, PLL, SSCG, and flash memory. However, because the PLL, SSCG, and flash memory are stopped, a setup time for the PLL, SSCG, and flash memory is required when IDLE2 mode is released.

- Cautions**
- 1. Insert five or more NOP instructions after the instruction that stores data in the PSC register to set the IDLE2 mode.**
  - 2. If the IDLE2 mode is set while an unmasked interrupt request signal is being held pending, the IDLE2 mode is released immediately by the pending interrupt request.**

### 26.5.2 Releasing IDLE2 mode

The IDLE2 mode is released by a non-maskable interrupt request signal (NMI pin input, INTWDT2 signal), unmasked external interrupt request signal (INTP0 to INTP9 pin input), unmasked internal interrupt request signal from the peripheral functions operable in the IDLE2 mode, or reset signal (RESET pin input, reset signal generation by overflow of watchdog timer 2 (WDT2RES), reset signal generation by low voltage detector (LVI) (LVIREs), or reset signal generation by clock monitor (CLM) (CLMRES)). The PLL returns to the operating status it was in before the IDLE2 mode was set.

After the IDLE2 mode has been released, the normal operation mode is restored.

#### (1) Releasing IDLE2 mode by non-maskable interrupt request signal or unmasked maskable interrupt request signal

The IDLE2 mode is released by a non-maskable interrupt request signal or an unmasked maskable interrupt request signal, regardless of the priority of the interrupt request signal. If the IDLE2 mode is set in an interrupt servicing routine, however, an interrupt request signal that is issued later is processed as follows.

- (a) If an interrupt request signal with a priority lower than that of the interrupt request currently being serviced is issued, the IDLE2 mode is released, but that interrupt request signal is not acknowledged. The interrupt request signal itself is retained.
- (b) If an interrupt request signal with a priority higher than that of the interrupt request currently being serviced is issued (including a non-maskable interrupt request signal), the IDLE2 mode is released and that interrupt request signal is acknowledged.

**Caution** The interrupt request signal that is disabled by setting the PSC.NMI1M, PSC.NMI0M, and PSC.INTM bits to 1 becomes invalid and IDLE2 mode is not released.

**Table 26-6. Operation After Releasing IDLE2 Mode by Interrupt Request Signal**

Release Source	Interrupt Enabled (EI) Status	Interrupt Disabled (DI) Status
Non-maskable interrupt request signal	Execution branches to the handler address after securing the prescribed setup time.	
Maskable interrupt request signal	Execution branches to the handler address or the next instruction is executed after securing the prescribed setup time.	The next instruction is executed after securing the prescribed setup time.

#### (2) Releasing IDLE2 mode by reset

The same operation as the normal reset operation is performed.

Table 26-7. Operating Status in IDLE2 Mode

Setting of IDLE2 Mode		Operating Status	
		When Subclock Is Not Used	When Subclock Is Used
Main clock oscillator		Oscillation enabled	
Subclock oscillator		–	Oscillation enabled
Internal oscillator		Oscillation enabled	
PLL		Stops operation	
SSCG		Stops operation	
CPU		Stops operation	
DMA		Stops operation	
Interrupt controller		Stops operation (but standby mode release is possible)	
ROM correction		Stops operation	
Timer P (TMP0 to TMP8)		Stops operation	
Timer Q (TMQ0)		Stops operation	
Timer M	TMM0	Operable when INTWT (when watch timer is operating) or $f_{R/8}$ is selected as the count clock	Operable when INTWT (when watch timer is operating), $f_{R/8}$ , or $f_{XT}$ is selected as the count clock
	TMM1	Operable when $f_{BRG}$ , $f_{R/8}$ , or INTTM0EQ0 (when TMM0 is operating) is selected as the count clock.	
	TMM2	Operable when $f_{BRG}$ , $f_{R/8}$ , or INTTM1EQ0 (when TMM1 is operating) is selected as the count clock.	
Watch timer		Operable when $f_{BRG}$ is selected as the count clock	Operable
Real-time counter (RTC)		Operable when $f_{BRG}$ is selected as the count clock	Operable
Watchdog timer 2		Operable when $f_{R/8}$ is selected as the count clock	Operable when $f_{R/8}$ or $f_{XT}$ is selected as the count clock
Serial interface	CSIB0 to CSIB5	Operable when the SCKBn input clock is selected as the transfer clock (n = 0 to 5)	
	CSIE0 <sup>Note 1</sup> , CSIE1 <sup>Note 1</sup>	Stops operation	
	I <sup>2</sup> C00 to I <sup>2</sup> C03, I <sup>2</sup> C04 <sup>Note 1</sup> , I <sup>2</sup> C05 <sup>Note 1</sup>	Stops operation	
	UARTA0 to UARTA5	Stops operation (but UARTA0 is operable when the ASCKA0 input clock is selected)	
	UARTB0, UARTB1	Stops operation	
CAN controller <sup>Note 2</sup>		Stops operation	
IEBus controller		Stops operation	
A/D converter		Holds operation (conversion result held) <sup>Note 3</sup>	
D/A converter		Holds operation (output held <sup>Note 3</sup> )	
Real-time output function (RTO)		Stops operation (output held)	
Key interrupt function (KR)		Operable	
CRC arithmetic circuit		Stops operation	
External bus interface		See 2.3 Pin States.	
Port function		Retains status before IDLE2 mode was set	
Internal data		The CPU registers, statuses, data, and all other internal data such as the contents of the internal RAM or expanded internal RAM are retained as they were before the IDLE2 mode was set.	

&lt;R&gt;

&lt;R&gt;

&lt;R&gt;

- Notes**
1. Not available in the  $\mu$ PD70F3931 (V850E/SJ3-H), 70F3932 (V850E/SJ3-H), and 70F3933 (V850E/SJ3-H)
  2. CAN controller versions only
  3. To realize low power consumption, stop the A/D converter and D/A converter before shifting to the IDLE2 mode.

### 26.5.3 Securing setup time when releasing IDLE2 mode

Secure the setup time after releasing the IDLE2 mode because the operation of the PLL, SSCG, and flash memory stops after the IDLE2 mode is set.

- Cautions**
1. In clock mode 1, if the system shifts to IDLE2 mode while the PLL is operating, be sure to set a setup time of at least  $800\ \mu\text{s}$  to be inserted after IDLE2 mode is released. If the PLL is stopped, set a setup time of at least  $350\ \mu\text{s}$  to be inserted after IDLE2 mode is released.
  2. In clock modes 2, 3, and 4, if the system shifts to IDLE2 mode while the SSCG is operating, be sure to set a setup time of at least  $1\ \text{ms}$  to be inserted after IDLE2 mode is released. If the SSCG is stopped, set a setup time of at least  $800\ \mu\text{s}$  to be inserted after IDLE2 mode is released.

#### (1) Releasing IDLE2 mode by non-maskable interrupt request signal or unmasked maskable interrupt request signal

Secure the specified setup time by setting the OSTS register.

When the releasing source is generated, the dedicated internal timer starts counting according to the OSTS register setting. When it overflows, the normal operation mode is restored.

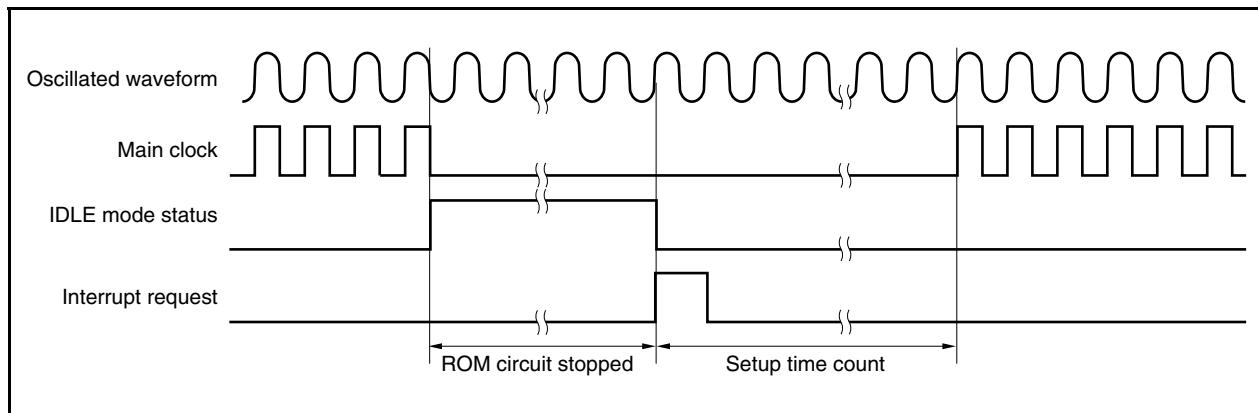

#### (2) Release by reset

This operation is the same as that of a normal reset.

The oscillation stabilization time is the initial value of the OSTS register,  $2^{16}/f_x$ .



## 26.6 STOP Mode

### 26.6.1 Setting and operation status

The STOP mode is set by setting the PSMR.PSM1 and PSMR.PSM0 bits to 01 or 11 and setting the PSC.STP bit to 1 in the normal operation mode.

In the STOP mode, the subclock oscillator and internal oscillator continue operating but the main clock oscillator stops. Clock supply to the CPU and the on-chip peripheral functions is stopped.

As a result, program execution stops, and the contents of the internal RAM and expanded internal RAM before the STOP mode was set are retained. Other on-chip peripheral functions stop operating. However, on-chip peripheral functions that can operate with the subclock ( $f_{\text{KT}}$ ), internal oscillation clock ( $f_{\text{R}}$ ), or an external clock continue operating.

Table 26-9 shows the operating status in the STOP mode.

Because the STOP mode stops operation of the main clock oscillator, it reduces the power consumption to a level lower than the IDLE2 mode. If the subclock oscillator, internal oscillator, and external clock are not used, the power consumption can be minimized with only leakage current flowing.

- Cautions**
1. Insert five or more NOP instructions after the instruction that stores data in the PSC register to set the STOP mode.
  2. If the STOP mode is set while an unmasked interrupt request signal is being held pending, the STOP mode is released immediately by the pending interrupt request.

### 26.6.2 Releasing STOP mode

The STOP mode is released by a non-maskable interrupt request signal (NMI pin input, INTWDT2 signal), unmasked external interrupt request signal (INTP0 to INTP9 pin input), unmasked internal interrupt request signal from the peripheral functions operable in the STOP mode, or reset signal ( $\overline{\text{RESET}}$  pin input, reset signal generation by overflow of watchdog timer 2 (WDT2RES), or reset signal generation by low voltage detector (LVI) (LVIRESS)).

After the STOP mode has been released, the normal operation mode is restored after the oscillation stabilization time has been secured.

#### (1) Releasing STOP mode by non-maskable interrupt request signal or unmasked maskable interrupt request signal

The STOP mode is released by a non-maskable interrupt request signal or an unmasked maskable interrupt request signal, regardless of the priority of the interrupt request signal. If the STOP mode is set in an interrupt servicing routine, however, an interrupt request signal that is issued later is serviced as follows.

- (a) If an interrupt request signal with a priority lower than that of the interrupt request currently being serviced is issued, the STOP mode is released, but that interrupt request signal is not acknowledged. The interrupt request signal itself is retained.
- (b) If an interrupt request signal with a priority higher than that of the interrupt request currently being serviced is issued (including a non-maskable interrupt request signal), the STOP mode is released and that interrupt request signal is acknowledged.

**Caution** The interrupt request that is disabled by setting the PSC.NMI1M, PSC.NMI0M, and PSC.INTM bits to 1 becomes invalid and STOP mode is not released.

**Table 26-8. Operation After Releasing STOP Mode by Interrupt Request Signal**

Release Source	Interrupt Enabled (EI) Status	Interrupt Disabled (DI) Status
Non-maskable interrupt request signal	Execution branches to the handler address after securing the oscillation stabilization time.	
Maskable interrupt request signal	Execution branches to the handler address or the next instruction is executed after securing the oscillation stabilization time.	The next instruction is executed after securing the oscillation stabilization time.

**(2) Releasing STOP mode by reset**

The same operation as the normal reset operation is performed.

Table 26-9. Operating Status in STOP Mode

Setting of STOP Mode		Operating Status	
		When Subclock Is Not Used	When Subclock Is Used
Main clock oscillator		Stops oscillation	
Subclock oscillator		–	Oscillation enabled
Internal oscillator		Oscillation enabled	
PLL		Stops operation	
SSCG		Stops operation	
CPU		Stops operation	
DMA		Stops operation	
Interrupt controller		Stops operation (but standby mode release is possible)	
ROM correction		Stops operation	
Timer P (TMP0 to TMP8)		Stops operation	
Timer Q (TMQ0)		Stops operation	
Timer M	TMM0	Operable when $f_{R/8}$ is selected as the count clock	Operable when INTWT (when watch timer is operating), $f_{R/8}$ , or $f_{XT}$ is selected as the count clock
	TMM1	Operable when $f_{R/8}$ or INTTM0EQ0 (when TMM0 is operating) is selected as the count clock.	
	TMM2	Operable when $f_{R/8}$ or INTTM1EQ0 (when TMM1 is operating) is selected as the count clock.	
Watch timer		Stops operation	Operable when $f_{XT}$ is selected as the count clock
Real-time counter (RTC)		Stops operation	Operable when $f_{XT}$ is selected as the count clock
Watchdog timer 2		Operable when $f_{R/8}$ is selected as the count clock	Operable when $f_{R/8}$ or $f_{XT}$ is selected as the count clock
Serial interface	CSIB0 to CSIB5	Operable when the SCKBn input clock is selected as the transfer clock (n = 0 to 5)	
	CSIE0 <sup>Note 1</sup> , CSIE1 <sup>Note 1</sup>	Stops operation	
	I <sup>2</sup> C00 to I <sup>2</sup> C03, I <sup>2</sup> C04 <sup>Note 1</sup> , I <sup>2</sup> C05 <sup>Note 1</sup>	Stops operation	
	UARTA0 to UARTA5	Stops operation (but UARTA0 is operable when the ASCKA0 input clock is selected)	
	UARTB0, UARTB1	Stops operation	
CAN controller <sup>Note 2</sup>		Stops operation	
IEBus controller		Stops operation	
A/D converter		Stops operation (conversion result undefined) <sup>Notes 3, 4</sup>	
D/A converter		Stops operation <sup>Notes 5, 6</sup> (high impedance is output)	
Real-time output function (RTO)		Stops operation (output held)	
Key interrupt function (KR)		Operable	
CRC arithmetic circuit		Stops operation	
External bus interface		See 2.3 Pin States.	
Port function		Retains status before STOP mode was set	
Internal data		The CPU registers, statuses, data, and all other internal data such as the contents of the internal RAM or expanded internal RAM are retained as they were before the STOP mode was set.	

&lt;R&gt;

&lt;R&gt;

&lt;R&gt;

**Notes 1.** Not available in the  $\mu$ PD70F3931 (V850E/SJ3-H), 70F3932 (V850E/SJ3-H), and 70F3933 (V850E/SJ3-H)

**2.** CAN controller versions only

- Notes 3.** If the STOP mode is set while the A/D converter is operating, the A/D converter is automatically stopped and starts operating again after the STOP mode is released. However, in that case, the A/D conversion results after the STOP mode is released are invalid. All the A/D conversion results before the STOP mode is set are invalid.
- 4.** Even if the STOP mode is set while the A/D converter is operating, the power consumption is reduced equivalently to when the A/D converter is stopped before the STOP mode is set.
- 5.** If the STOP mode is set while the D/A converter is operating, the D/A converter is automatically stopped and the pin status becomes high impedance. After the STOP mode is released, D/A conversion resumes, the setting time elapses, and the status returns to the output level before the STOP mode was set.
- 6.** Even if the STOP mode is set while the D/A converter is operating, the power consumption is reduced equivalently to when the D/A converter is stopped before the STOP mode is set.

**26.6.3 Securing oscillation stabilization time when releasing STOP mode**

Secure the oscillation stabilization time for the main clock oscillator after releasing the STOP mode because the operation of the main clock oscillator stops after STOP mode is set.

- Cautions 1.** In clock mode 1, if the system shifts to STOP mode while the PLL is operating, be sure to set an oscillation stabilization time of at least 1 ms to be inserted after STOP mode is released.
- 2.** In clock modes 2, 3, and 4, if the system shifts to STOP mode while the SSCG is operating, be sure to set an oscillation stabilization time of at least 2 ms to be inserted after STOP mode is released.

**(1) Releasing STOP mode by non-maskable interrupt request signal or unmasked maskable interrupt request signal**

Secure the oscillation stabilization time by setting the OSTS register.

When the releasing source is generated, the dedicated internal timer starts counting according to the OSTS register setting. When it overflows, the normal operation mode is restored.

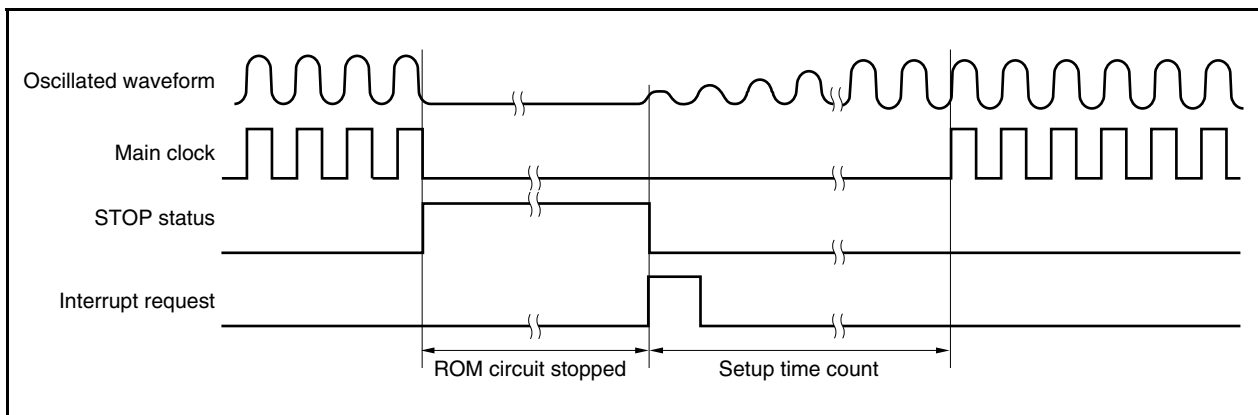

**(2) Releasing STOP mode by reset**

This operation is the same as that of a normal reset.

The oscillation stabilization time is the initial value of the OSTS register,  $2^{16}/f_x$ .

## 26.7 Subclock Operation Mode

### 26.7.1 Setting and operation status

The subclock operation mode is set by setting the PCC.CK3 bit to 1 in the normal operation mode.

When the subclock operation mode is set, the internal system clock is changed from the main clock to the subclock. Check whether the clock has been switched by using the PCC.CLS bit.

When the PCC.MCK bit is set to 1, the operation of the main clock oscillator is stopped. As a result, the system operates only on the subclock.

In the subclock operation mode, the power consumption can be reduced to a level lower than in the normal operation mode because the subclock is used as the internal system clock. In addition, the power consumption can be further reduced to the level of the STOP mode by stopping the operation of the main clock oscillator.

Table 26-10 shows the operating status in subclock operation mode.

- Cautions**
1. **Secure the oscillation stabilization time of the subclock oscillator before shifting to subclock operation mode. The subclock oscillator starts oscillation after power is applied.**
  2. **Before setting subclock operation mode, be sure to stop operation of the SSCG (SSCGCTL.SSCGON bit = 0). Note that the SSCG cannot be used in clock mode 1.**
  3. **When manipulating the CK3 bit, do not change the set values of the PCC.CK2 to PCC.CK0 bits (using a bit manipulation instruction to manipulate the bit is recommended). For details of the PCC register, see 6.3 (1) Processor clock control register (PCC).**
  4. **If the following conditions are not satisfied, change the CK2 to CK0 bits so that the conditions are satisfied and set the subclock operation mode.**  

$$\text{Internal system clock (f}_{\text{CLK}}) > \text{Subclock (f}_{\text{XT}} = 32.768 \text{ kHz}) \times 4$$
  5. **When stopping operation of the main clock oscillator, be sure to also stop operation of the on-chip peripheral functions operating on the main oscillation clock (f<sub>x</sub>) and peripheral clock (f<sub>xP</sub>).**
  6. **In clock modes 2, 3 and 4, do not clear (0) the PLLCTL.PLLON bit by software (i.e., do not stop the PLL). When the main clock oscillator stops operating (PCC.MCK bit = 1), the PLL automatically stops operating at the same time, with the PLLCTL.PLLON bit still set to 1 (PLL operation enabled). Similarly, when the main clock oscillator is set to operation enabled again (PCC.MCK bit = 0), the PLL also starts operating, and enters a locked state until the oscillation stabilization time secured by software elapses (at least 1 ms).**

**Remark** Internal system clock (f<sub>CLK</sub>): Clock generated from main clock (f<sub>xx</sub>) in accordance with the settings of the CK2 to CK0 bits

### 26.7.2 Releasing subclock operation mode

The subclock operation mode is released by a reset signal ( $\overline{\text{RESET}}$  pin input, reset signal (WDT2RES) generation by overflow of watchdog timer 2, reset signal (LVIREs) generation by low voltage detector (LVI), or reset signal (CLMRES) generation by clock monitor (CLM)) when the CK3 bit is cleared to 0.

If the main clock oscillator is stopped (MCK bit = 1), set the MCK bit to 0, secure the oscillation stabilization time of the main clock oscillator by software, and set the CK3 bit to 0.

The normal operation mode is restored when the subclock operation mode is released.

**Caution** When manipulating the CK3 bit, do not change the set values of the CK2 to CK0 bits (using a bit manipulation instruction to manipulate the bit is recommended).

For details of the PCC register, see 6.3 (1) Processor clock control register (PCC).

Table 26-10. Operating Status in Subclock Operation Mode

Setting of Subclock Operation Mode Item		Operating Status	
		When Main Clock Is Oscillating	When Main Clock Is Stopped
Subclock oscillator		Oscillation enabled	
Internal oscillator		Oscillation enabled	
PLL		Operable	Stops operation <sup>Note 5</sup>
SSCG		Disables operation <sup>Note 4</sup>	
CPU		Operable	
DMA		Operable	
Interrupt controller		Operable	
ROM correction		Operable	
Timer P (TMP0 to TMP8) <sup>Note 1</sup>		Operable	Disables operation
Timer Q (TMQ0) <sup>Note 1</sup>		Operable	Disables operation
Timer M	TMM0 <sup>Note 1</sup>	Operable	Operable when INTWT (when watch timer is operating), $f_{R/8}$ or $f_{XT}$ is selected as the count clock
	TMM1 <sup>Note 1</sup>	Operable	Operable when $f_{R/8}$ or INTTM0EQ0 (when TMM0 is operating) is selected as the count clock.
	TMM2 <sup>Note 1</sup>	Operable	Operable when $f_{R/8}$ or INTTM1EQ0 (when TMM1 is operating) is selected as the count clock.
Watch timer <sup>Note 1</sup>		Operable	Operable when $f_{XT}$ is selected as the count clock
Real-time counter (RTC) <sup>Note 1</sup>		Operable	Operable when $f_{XT}$ is selected as the count clock
Watchdog timer 2		Operable	Operable when $f_{R/8}$ or $f_{XT}$ is selected as the count clock
<R> <R> <R>	Serial interface	CSIB0 to CSIB5 <sup>Note 1</sup>	Operable when the SCKBn input clock is selected as the transfer clock (n = 0 to 5)
		CSIE0 <sup>Notes 1, 2</sup> , CSIE1 <sup>Notes 1, 2</sup>	Disables operation
		I <sup>2</sup> C00 to I <sup>2</sup> C03 <sup>Note 1</sup> , I <sup>2</sup> C04 <sup>Notes 1, 2</sup> , I <sup>2</sup> C05 <sup>Notes 1, 2</sup>	Disables operation
		UARTA0 to UARTA5 <sup>Note 1</sup>	Disables operation (but UARTA0 is operable when the ASCKA0 input clock is selected)
		UARTB0 <sup>Note 1</sup> , UARTB1 <sup>Note 1</sup>	Disables operation
CAN controller <sup>Notes 1, 3</sup>		Operable	Disables operation
IEBus controller <sup>Note 1</sup>		Operable	Disables operation
A/D converter <sup>Note 1</sup>		Operable	Disables operation
D/A converter		Operable	
Real-time output function (RTO)		Operable	Stops operation (output held)
Key interrupt function (KR)		Operable	
CRC arithmetic circuit		Operable	
External bus interface		Operable	
Port function		Settable	
Internal data		Settable	

- <R>
- Notes 1.** When stopping the main clock oscillator, be sure to disable the on-chip peripheral functions that are operating on the main oscillation clock ( $f_x$ ) or peripheral clock ( $f_{XP}$ ,  $f_{IE}$ ,  $f_{CAN}$ ).
2. Not available in the  $\mu$ PD70F3931 (V850E/SJ3-H), 70F3932 (V850E/SJ3-H), and 70F3933 (V850E/SJ3-H)
  3. CAN controller versions only.
  4. Before shifting to subclock operation mode, be sure to stop operation of the SSCG (SSCGCTL.SSCGON bit = 0). Note that the SSCG cannot be used in clock mode 1.
  5. When the main clock oscillator stops operating, the PLL automatically stops. In clock modes 2, 3, and 4, do not stop the PLL by software (i.e., do not clear (0) the PLLCTL.PLLON bit).

**Caution** When the CPU is operating on the subclock and main clock oscillation is stopped, accessing a register in which a wait occurs is disabled. If a wait is generated, it can be released only by reset (see 3.4.9 (2)).

## 26.8 Sub-IDLE Mode

### 26.8.1 Setting and operation status

The sub-IDLE mode is set by setting the PSMR.PSM1 and PSMR.PSM0 bits to 00 or 10 and setting the PSC.STP bit to 1 in the subclock operation mode.

In this mode, the clock oscillator continues operating but clock supply to the CPU, flash memory, and the other on-chip peripheral functions is stopped.

As a result, program execution stops and the contents of the internal RAM and expanded internal RAM before the sub-IDLE mode was set are retained. The CPU and the other on-chip peripheral functions are stopped. However, the on-chip peripheral functions that can operate with the main oscillation clock ( $f_x$ ), subclock ( $f_{xT}$ ), or internal oscillation clock ( $f_R$ ) continue operating.

Because the sub-IDLE mode stops operation of the CPU, flash memory, and other on-chip peripheral functions, it can reduce the power consumption more than the subclock operation mode. If the sub-IDLE mode is set after the main clock has been stopped, the current consumption can be reduced to a level as low as that in the STOP mode.

Table 26-12 shows the operating status in the sub-IDLE mode.

- Cautions**
1. Following the store instruction to the PSC register for setting the sub-IDLE mode, insert the five or more NOP instructions.
  2. If the sub-IDLE mode is set while an unmasked interrupt request signal is being held pending, the sub-IDLE mode is then released immediately by the pending interrupt request.
  3. When stopping operation of the main clock oscillator, be sure to also stop operation of the on-chip peripheral functions operating on the main oscillation clock ( $f_x$ ) and peripheral clock ( $f_{xP}$ ).
  4. In clock modes 2, 3, and 4, do not clear (0) the PLLCTL.PLLON bit by software (i.e., do not stop the PLL). When the main clock oscillator stops operating (PCC.MCK bit = 1), the PLL automatically stops operating at the same time, with the PLLCTL.PLLON bit still set to 1 (PLL operation enabled). Similarly, when the main clock oscillator is set to operation enabled again (PCC.MCK bit = 0), the PLL also starts operating, and enters a locked state until the oscillation stabilization time secured by software elapses (at least 1 ms).



### 26.8.2 Releasing sub-IDLE mode

The sub-IDLE mode is released by a non-maskable interrupt request signal (NMI pin input, INTWDT2 signal), unmasked external interrupt request signal (INTP0 to INTP9 pin input), unmasked internal interrupt request signal from the peripheral functions operable in the sub-IDLE mode, or reset signal ( $\overline{\text{RESET}}$  pin input, reset signal (WDT2RES) generation by overflow of watchdog timer 2, reset signal (LVIREs) generation by low voltage detector (LVI), or reset signal (CLMRES) generation by clock monitor (CLM)). The PLL returns to the operating status it was in before the sub-IDLE mode was set.

When the sub-IDLE mode is released by an interrupt request signal, the subclock operation mode is set.

#### (1) Releasing sub-IDLE mode by non-maskable interrupt request signal or unmasked maskable interrupt request signal

The sub-IDLE mode is released by a non-maskable interrupt request signal or an unmasked maskable interrupt request signal, regardless of the priority of the interrupt request signal.

If the sub-IDLE mode is set in an interrupt servicing routine, however, an interrupt request signal that is issued later is serviced as follows.

- (a) If an interrupt request signal with a priority lower than that of the interrupt request currently being serviced is issued, the sub-IDLE mode is released, but that interrupt request signal is not acknowledged. The interrupt request signal itself is retained.
- (b) If an interrupt request signal with a priority higher than that of the interrupt request currently being serviced is issued (including a non-maskable interrupt request signal), the sub-IDLE mode is released and that interrupt request signal is acknowledged.

- Cautions 1. The interrupt request signal that is disabled by setting the PSC.NMI1M, PSC.NMI0M, and PSC.INTM bits to 1 becomes invalid and sub-IDLE mode is not released.**
- 2. When the sub-IDLE mode is released, 12 cycles of the subclock (about 366  $\mu\text{s}$ ) elapse from when the interrupt request signal that releases the sub-IDLE mode is generated to when the mode is released.**

**Table 26-11. Operation After Releasing Sub-IDLE Mode by Interrupt Request Signal**

Release Source	Interrupt Enabled (EI) Status	Interrupt Disabled (DI) Status
Non-maskable interrupt request signal	Execution branches to the handler address.	
Maskable interrupt request signal	Execution branches to the handler address or the next instruction is executed.	The next instruction is executed.

#### (2) Releasing sub-IDLE mode by reset

The same operation as the normal reset operation is performed.

Table 26-12. Operating Status in Sub-IDLE Mode

Setting of Sub-IDLE Mode		Operating Status	
		When Main Clock Is Oscillating	When Main Clock Is Stopped
Subclock oscillator		Oscillation enabled	
Internal oscillator		Oscillation enabled	
PLL		Operable	Stops operation <sup>Note 5</sup>
SSCG		Disables operation <sup>Note 4</sup>	
CPU		Stops operation	
DMA		Stops operation	
Interrupt controller		Stops operation (but standby mode release is possible)	
ROM correction		Stops operation	
Timer P (TMP0 to TMP8) <sup>Note 1</sup>		Stops operation	Disables operation
Timer Q (TMQ0) <sup>Note 1</sup>		Stops operation	Disables operation
Timer M	TMM0 <sup>Note 1</sup>	Operable when INTWT (when watch timer is operating), $f_{R/8}$ , or $f_{XT}$ is selected as the count clock	
	TMM1 <sup>Note 1</sup>	Operable when $f_{BRG}$ , $f_{R/8}$ , or INTTM0EQ0 (when TMM0 is operating) is selected as the count clock.	Operable when $f_{R/8}$ or INTTM0EQ0 (when TMM0 is operating) is selected as the count clock.
	TMM2 <sup>Note 1</sup>	Operable when $f_{BRG}$ , $f_{R/8}$ , or INTTM1EQ0 (when TMM1 is operating) is selected as the count clock.	Operable when $f_{R/8}$ or INTTM1EQ0 (when TMM1 is operating) is selected as the count clock.
Watch timer <sup>Note 1</sup>		Operable	Operable when $f_{XT}$ is selected as the count clock
Real-time counter (RTC) <sup>Note 1</sup>		Operable	Operable when $f_{XT}$ is selected as the count clock
Watchdog timer 2		Operable when $f_{R/8}$ or $f_{XT}$ is selected as the count clock	
Serial interface	CSIB0 to CSIB5 <sup>Note 1</sup>	Operable when the $\overline{SCKBn}$ input clock is selected as the count clock ( $n = 0$ to $5$ )	
	CSIE0 <sup>Notes 1, 2</sup> , CSIE1 <sup>Notes 1, 2</sup>	Stops operation	Disables operation
	I <sup>2</sup> C00 to I <sup>2</sup> C03 <sup>Note 1</sup> , I <sup>2</sup> C04 <sup>Notes 1, 2</sup> , I <sup>2</sup> C05 <sup>Notes 1, 2</sup>	Stops operation	Disables operation
	UARTA0 to UARTA5 <sup>Note 1</sup>	Stops operation (but UARTA0 is operable when the ASCKA0 input clock is selected)	Disables operation (but UARTA0 is operable when the ASCKA0 input clock is selected)
	UARTB0 <sup>Note 1</sup> , UARTB1 <sup>Note 1</sup>	Stops operation	Disables operation
CAN controller <sup>Notes 1, 3</sup>		Stops operation	Disables operation
IEBus controller <sup>Note 1</sup>		Stops operation	Disables operation
A/D converter <sup>Note 1</sup>		Holds operation (conversion result held) <sup>Note 6</sup>	Disables operation
D/A converter		Holds operation (output held <sup>Note 6</sup> )	
Real-time output function (RTO)		Stops operation (output held)	
Key interrupt function (KR)		Operable	
CRC arithmetic circuit		Stops operation	
External bus interface		See <b>2.3 Pin States</b> (same operation status as IDLE1, IDLE2 mode).	
Port function		Retains status before sub-IDLE mode was set	
Internal data		The CPU registers, statuses, data, and all other internal data such as the contents of the internal RAM or expanded internal RAM are retained as they were before the sub-IDLE mode was set.	

<R>  
<R>

**Note 1.** When stopping the main clock oscillator, disable the on-chip peripheral functions operating on the main oscillation clock ( $f_x$ ) and peripheral clock ( $f_{XP}$ ,  $f_{IE}$ ,  $f_{CAN}$ ).

- <R>      **Notes**
- 2.** Not available in the  $\mu$ PD70F3931 (V850E/SJ3-H), 70F3932 (V850E/SJ3-H), and 70F3933 (V850E/SJ3-H)
  - 3.** CAN controller versions only.
  - 4.** Stop the SSCG (SSCGCTL.SSCGON bit = 0) before shifting to subclock operation mode. Note that the SSCG cannot be used in clock mode 1.
  - 5.** When the main clock oscillator stops, the PLL stops automatically. In clock modes 2, 3, and 4, do not stop the PLL by software (i.e., do not clear (0) the PLLCTL.PLLON bit).
  - 6.** To realize low power consumption, stop the A/D and D/A converters before shifting to the sub-IDLE mode.



Figure 26-1. Status Transition Diagram for Using Clock Mode 1 (2/2)

- Notes 6.** If the system shifts to STOP mode while the A/D converter is operating, the A/D converter will automatically stop while STOP mode is in effect, and will resume operating after STOP mode is released. In this case, however, the A/D conversion results after STOP mode is released will be invalid. In addition, all the A/D conversion results before the system shifted to STOP mode will also be invalid.
7. If the system shifts to STOP mode while the D/A converter is operating, the D/A converter will automatically stop while STOP mode is in effect, and the status of its pins will be high impedance. The D/A converter will resume operating after STOP mode is released, and, after the settling time has elapsed, its pins will output the level they were outputting before the system shifted to STOP mode.
8. If a WDT2 overflow occurs during the oscillation stabilization time, the system will switch from the internal system clock ( $f_{CLK}$ ) to the internal oscillation clock ( $f_R$ ) and continue operating.

**Remark** fx: Main oscillation clock frequency

(2) Status transition diagram for using clock modes 2, 3, and 4

Figure 26-2. Status Transition Diagram for Using Clock Modes 2, 3, and 4 (1/2)

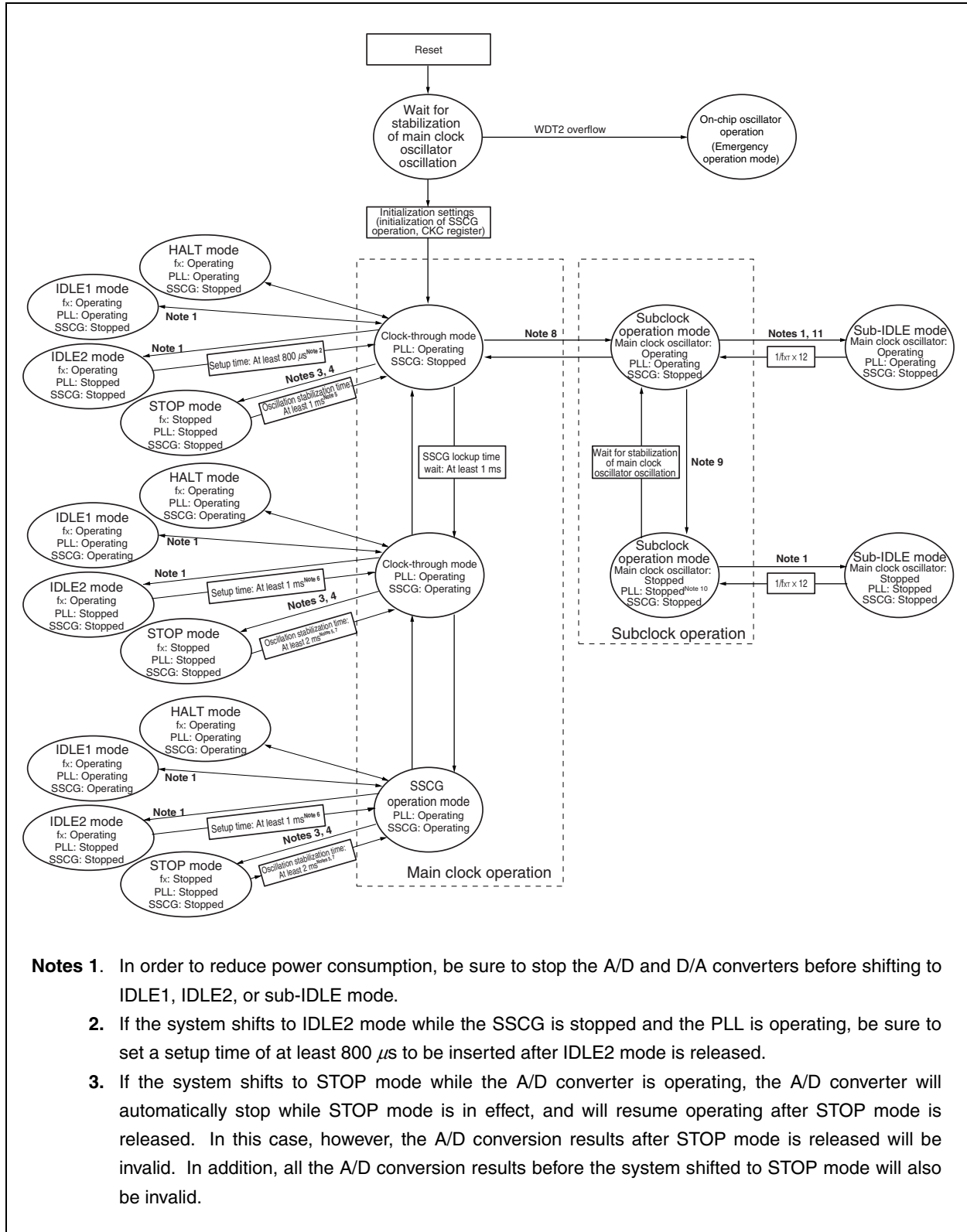

**Notes 1.** In order to reduce power consumption, be sure to stop the A/D and D/A converters before shifting to IDLE1, IDLE2, or sub-IDLE mode.

**2.** If the system shifts to IDLE2 mode while the SSCG is stopped and the PLL is operating, be sure to set a setup time of at least 800 μs to be inserted after IDLE2 mode is released.

**3.** If the system shifts to STOP mode while the A/D converter is operating, the A/D converter will automatically stop while STOP mode is in effect, and will resume operating after STOP mode is released. In this case, however, the A/D conversion results after STOP mode is released will be invalid. In addition, all the A/D conversion results before the system shifted to STOP mode will also be invalid.

**Figure 26-2. Status Transition Diagram for Using Clock Modes 2, 3, and 4 (2/2)**

- Notes 4.** If the system shifts to STOP mode while the D/A converter is operating, the D/A converter will automatically stop while STOP mode is in effect, and the status of its pins will be high impedance. The D/A converter will resume operating after STOP mode is released, and, after the settling time has elapsed, its pins will output the level they were outputting before the system shifted to STOP mode.
5. If a WDT2 overflow occurs during the oscillation stabilization time, the system will switch from the internal system clock ( $f_{CLK}$ ) to the on-chip oscillation clock ( $f_R$ ) and continue operating.
  6. If the system shifts to IDLE2 mode while the SSCG is operating, be sure to set a setup time of at least 1 ms to be inserted after IDLE2 mode is released.
  7. If the system shifts to STOP mode while the SSCG is operating, be sure to set an oscillation stabilization time of at least 2 ms to be inserted after STOP mode is released.
  8. Before shifting to subclock operation mode, set clock-through mode and stop operation of the SSCG (SSCGCTL.SSCGON bit = 0).
  9. When stopping the main clock oscillator, set the on-chip peripheral functions operating on the main oscillation clock ( $f_x$ ) and peripheral clock ( $f_{XP}$ ,  $f_{IE}$ ,  $f_{CAN}$ ) to operation stopped.
  10. When the main clock oscillator stops, the PLL stops automatically.
  11. In order to reduce power consumption, be sure to stop the A/D and D/A converters before shifting to sub-IDLE mode.

**Caution** In clock modes 2, 3, and 4, do not clear (0) the PLLCTL.PLLON bit by software (i.e., do not stop the PLL).

**Remark**  $f_x$ : Main oscillation clock frequency

## CHAPTER 27 RESET FUNCTIONS

### 27.1 Overview

The following reset functions are available.

(1) Four kinds of reset sources

- External reset input via the RESET pin
- Reset via the watchdog timer 2 (WDT2) overflow (WDT2RES)
- System reset via the comparison of the low-voltage detector (LVI) supply voltage and detected voltage (LVIRES)
- System reset via the detecting clock monitor (CLM) oscillation stop (CLMRES)

After a reset is released, the source of the reset can be confirmed with the reset source flag register (RESF).

(2) Emergency operation mode

If the WDT2 overflows during the main clock oscillation stabilization time inserted after a reset is released or STOP mode is released, a main clock oscillation anomaly is judged and the CPU starts operating on the internal oscillation clock.

**Caution** In emergency operation mode, do not access on-chip peripheral I/O registers other than registers used for interrupts, ports, WDT2, or TMM0, each of which can operate on the internal oscillation clock.

<R> In addition, CSIB0 to CSIB5, CSIE0<sup>Note</sup>, CSIE1<sup>Note</sup>, and UARTA0 cannot operate on an externally input clock in this mode.

<R> **Note** Not available in the  $\mu$ PD70F3931 (V850E/SJ3-H), 70F3932 (V850E/SJ3-H), and 70F3933 (V850E/SJ3-H)



Figure 27-1. Block Diagram of Reset Function

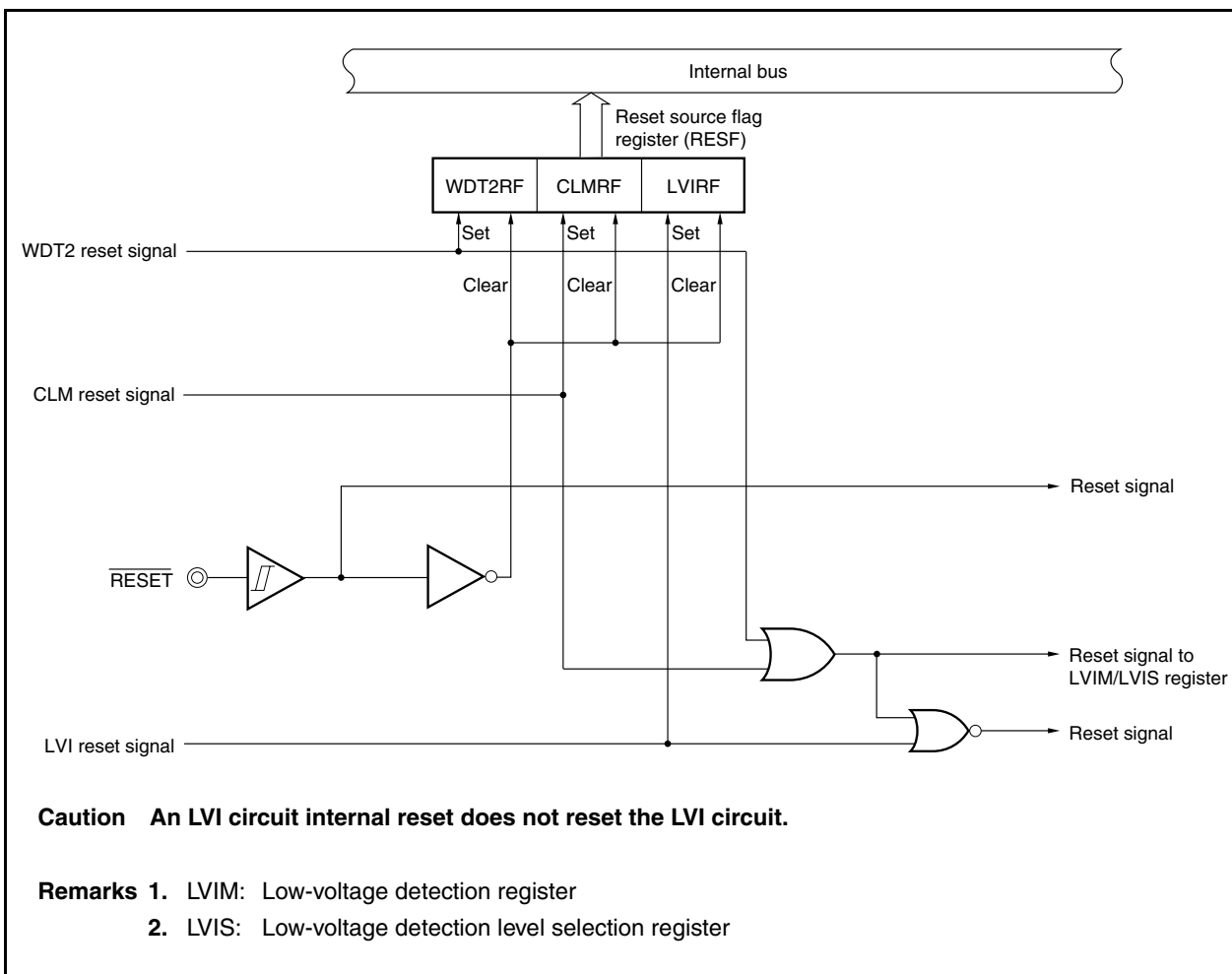

## 27.2 Registers to Check Reset Source

The V850E/SJ3-H and V850E/SK3-H have four kinds of reset sources. After a reset has been released, the source of the reset that occurred can be checked with the reset source flag register (RESF).

### (1) Reset source flag register (RESF)

The RESF register is a special register that can be written only by a combination of specific sequences (see **3.4.8 Special registers**).

The RESF register indicates the source from which a reset signal is generated.

This register is read or written in 8-bit or 1-bit units.

$\overline{\text{RESET}}$  pin input clears this register to 00H. The default value differs if the source of reset is other than the  $\overline{\text{RESET}}$  pin signal.

After reset: 00H<sup>Note</sup> R/W Address: FFFF888H

	7	6	5	4	3	2	1	0
RESF	0	0	0	WDT2RF	0	0	CLMRF	LVIRF

WDT2RF	Reset signal from WDT2
0	Not generated
1	Generated

CLMRF	Reset signal from CLM
0	Not generated
1	Generated

LVIRF	Reset signal from LVI
0	Not generated
1	Generated

**Note** The value of the RESF register is cleared to 00H when a reset is executed via the  $\overline{\text{RESET}}$  pin. When a reset is executed by the watchdog timer 2 (WDT2), clock monitor (CLM), or low-voltage detector (LVI), the reset flags of this register (WDT2RF bit, CLMRF bit, and LVIRF bit) are set. However, other sources are retained.

**Cautions** 1. Only “0” can be written to each bit of this register. If writing “0” conflicts with setting the flag (occurrence of reset), setting the flag takes precedence.

2. Be sure to set bits 2, 3, and 5 to 7 to “0”.

## 27.3 Operation

### 27.3.1 Reset operation via $\overline{\text{RESET}}$ pin

When a low level is input to the  $\overline{\text{RESET}}$  pin, the system is reset, and each hardware unit is initialized.

When the level of the  $\overline{\text{RESET}}$  pin is changed from low to high, the reset status is released.

**Table 27-1. Hardware Status on  $\overline{\text{RESET}}$  Pin Input**

Item	During Reset	After Reset
Main clock oscillator ( $f_x$ )	Oscillation stops	Oscillation starts
Subclock oscillator ( $f_{XT}$ )	Oscillation continues	
Internal oscillator	Oscillation stops	Oscillation starts
Peripheral clock ( $f_{XP}$ to $f_{XP}/1,024$ )	Operation stops	Operation starts after securing oscillation stabilization time
Internal system clock ( $f_{CLK}$ ), CPU clock ( $f_{CPU}$ )	Operation stops	Operation starts after securing oscillation stabilization time (initialized to $f_{xx}/8$ )
CPU	Initialized	Program execution starts after securing oscillation stabilization time
Watchdog timer 2	Operation stops (initialized to 0)	Counts up from 0 with internal oscillation clock as source clock.
Internal RAM, expanded internal RAM	Undefined if power-on reset or CPU access and reset input conflict (data is damaged). Otherwise value immediately after reset input is retained. The value immediately before the reset is retained if a reset signal is input in IDLE1, IDLE2, STOP, or sub-IDLE mode.	
I/O lines (ports/alternate-function pins)	High impedance <sup>Note</sup>	
On-chip peripheral I/O registers	Initialized to specified status, OCDM register is set (01H).	
Other on-chip peripheral functions	Operation stops	Operation can be started after securing oscillation stabilization time

**Note** When the power is turned on, the following pins may momentarily output an undefined level.

- P53/SIB2/KR3/TIQ00/TOQ00/RTP03/DDO pin

**Caution** The OCDM register is initialized by the  $\overline{\text{RESET}}$  pin input. Therefore, note with caution that, if a high level is input to the P05/ $\overline{\text{DRST}}$  pin after a reset release before the OCDM.OCDM0 bit is cleared, the V850E/SJ3-H or V850E/SK3-H may enter on-chip debug mode. For details, refer to CHAPTER 4 PORT FUNCTIONS.

Figure 27-2. Timing of Reset Operation by  $\overline{\text{RESET}}$  Pin Input

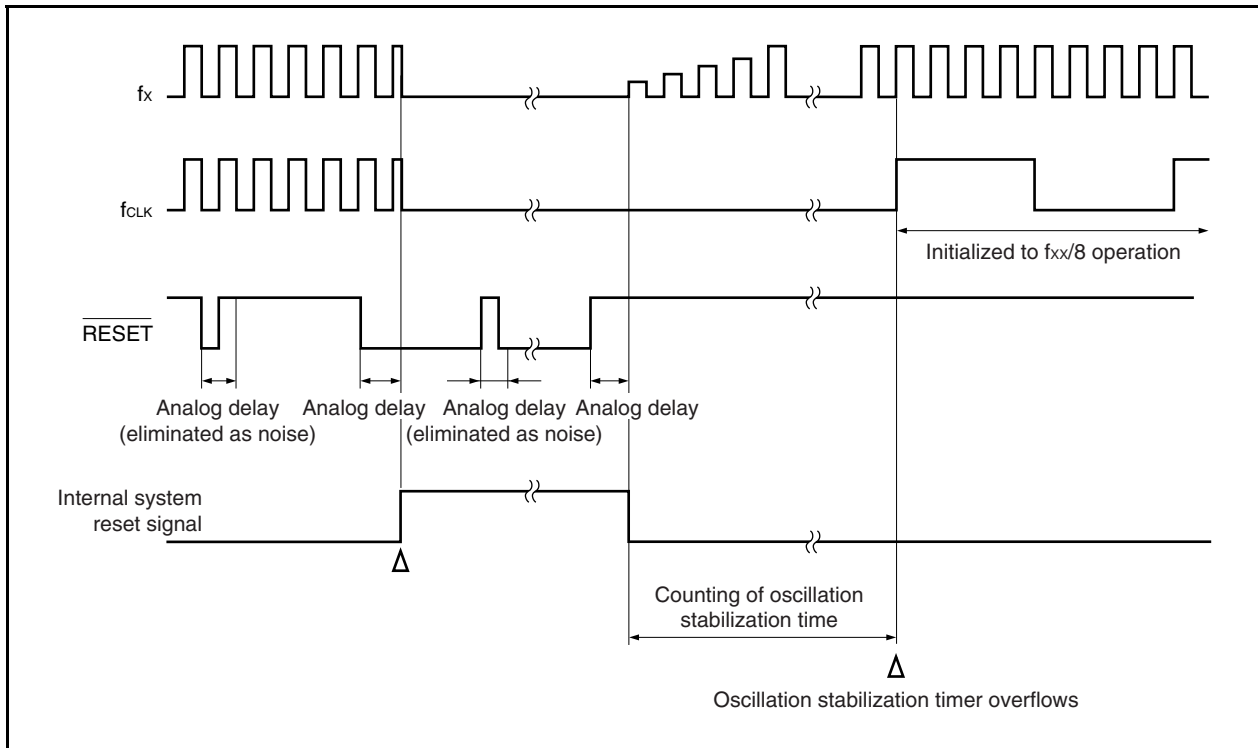
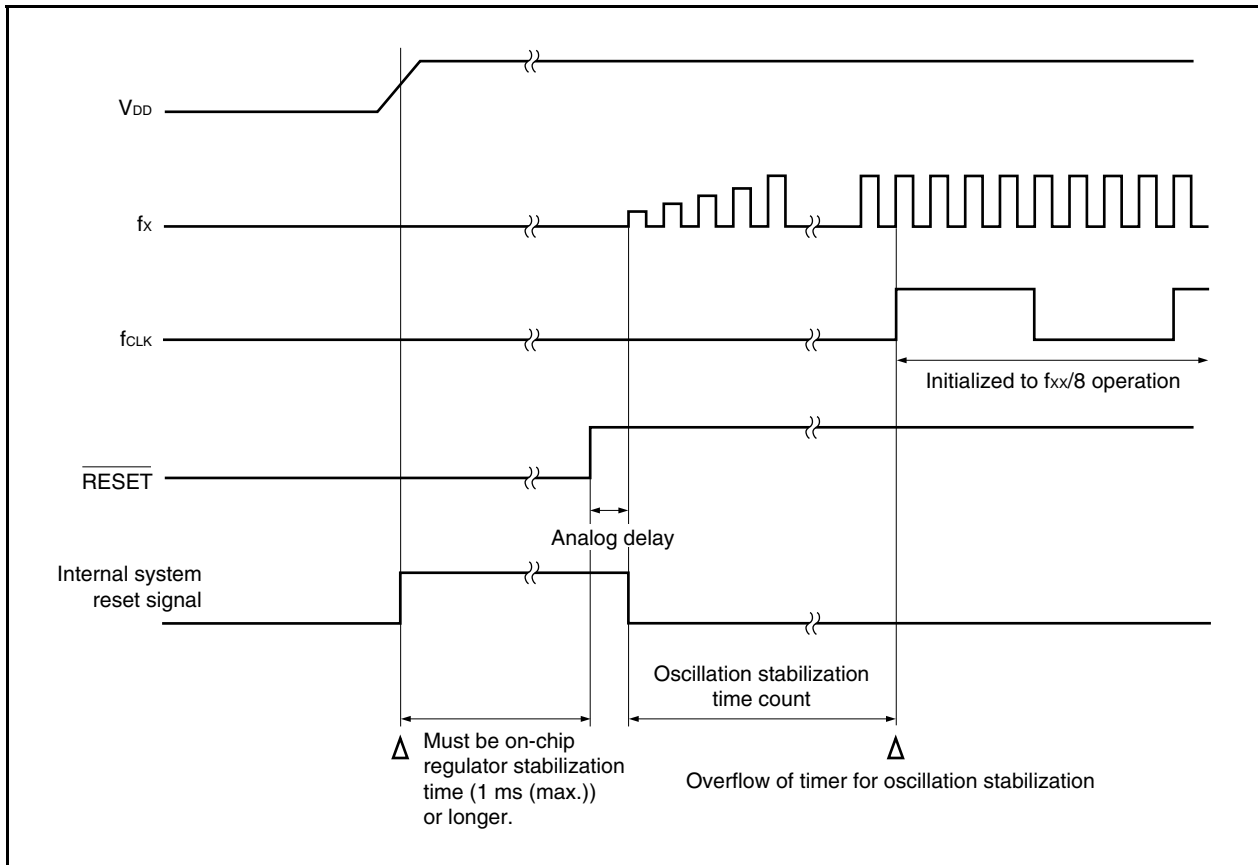

Figure 27-3. Timing of Power-on Reset Operation



### 27.3.2 Reset operation by watchdog timer 2 (WDT2RES)

When watchdog timer 2 is set to the reset operation mode due to overflow, upon watchdog timer 2 overflow (WDT2RES signal generation), a system reset is executed and the hardware is initialized to the initial status.

Following watchdog timer 2 overflow, the reset status is entered and lasts the predetermined time (analog delay), and the reset status is then automatically released.

The main clock oscillator is stopped during the reset period.

**Table 27-2. Hardware Status During Watchdog Timer 2 Reset Operation**

Item	During Reset	After Reset
Main clock oscillator ( $f_x$ )	Oscillation stops	Oscillation starts
Subclock oscillator ( $f_{XT}$ )	Oscillation continues	
Internal oscillator	Oscillation stops	Oscillation starts
Peripheral clock ( $f_{XP}$ to $f_{XP}/1,024$ )	Operation stops	Operation starts after securing oscillation stabilization time
Internal system clock ( $f_{CLK}$ ), CPU clock ( $f_{CPU}$ )	Operation stops	Operation starts after securing oscillation stabilization time (initialized to $f_{XX}/8$ )
CPU	Initialized	Program execution after securing oscillation stabilization time
Watchdog timer 2	Operation stops (initialized to 0)	Counts up from 0 with internal oscillation clock as source clock.
Internal RAM, expanded internal RAM	Undefined if power-on reset or CPU access and reset input conflict (data is damaged). Otherwise value immediately after reset input is retained. The value immediately before the reset is retained if a reset signal is input in IDLE1, IDLE2, STOP, or sub-IDLE mode.	
I/O lines (ports/alternate-function pins)	High impedance	
On-chip peripheral I/O register	Initialized to specified status, OCDM register retains its value.	
On-chip peripheral functions other than above	Operation stops	Operation can be started after securing oscillation stabilization time.

Figure 27-4. Timing of Reset Operation by WDT2RES Signal Generation

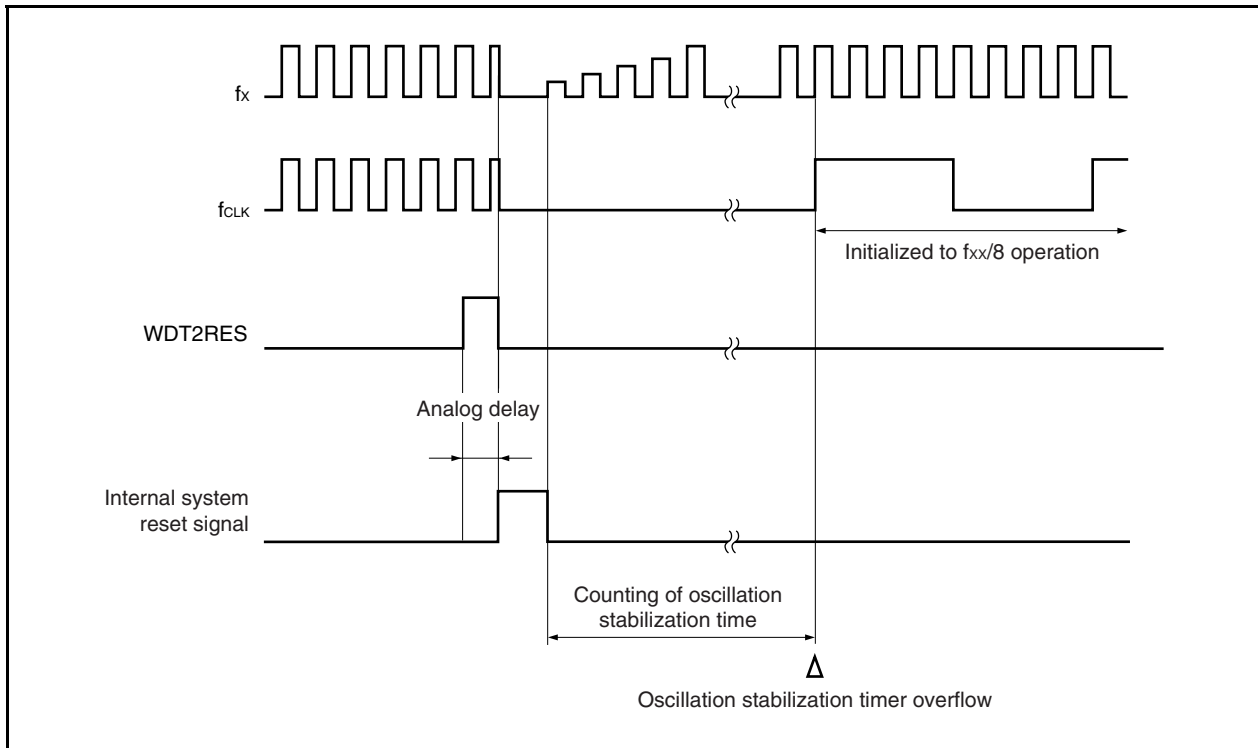

### 27.3.3 Reset operation by low-voltage detector (LVIRES)

If the supply voltage falls below the voltage detected by the low-voltage detector when LVI operation is enabled, a system reset is executed (when the LVIM.LVIMD bit is set to 1), and the hardware is initialized to the initial status.

The reset status lasts from when a supply voltage drop has been detected until the supply voltage rises above the LVI detection voltage.

The main clock oscillator is stopped during the reset period.

When the LVIMD bit = 0, an interrupt request signal (INTLVI) is generated if a low voltage is detected.

**Table 27-3. Hardware Status During Reset Operation by Low-Voltage Detector**

Item	During Reset	After Reset
Main clock oscillator ( $f_x$ )	Oscillation stops	Oscillation starts
Subclock oscillator ( $f_{XT}$ )	Oscillation continues	
Internal oscillator	Oscillation stops	Oscillation starts
Peripheral clock ( $f_{XP}$ to $f_{XP}/1,024$ )	Operation stops	Operation starts after securing oscillation stabilization time
Internal system clock ( $f_{CLK}$ ), CPU clock ( $f_{CPU}$ )	Operation stops	Operation starts after securing oscillation stabilization time (initialized to $f_{xx}/8$ )
CPU	Initialized	Program execution starts after securing oscillation stabilization time
WDT2	Operation stops (initialized to 0)	Counts up from 0 with internal oscillation clock as source clock.
Internal RAM, expanded internal RAM	Undefined if power-on reset or CPU access and reset input conflict (data is damaged). Otherwise value immediately after reset input is retained. The value immediately before the reset input is retained if a reset signal is input in IDLE1, IDLE2, STOP, or sub-IDLE mode.	
I/O lines (ports/alternate-function pins)	High impedance	
On-chip peripheral I/O register	Initialized to specified status, OCDM register retains its value.	
LVI	Operation continues	
On-chip peripheral functions other than above	Operation stops	Operation can be started after securing oscillation stabilization time.

**Remark** The reset timing of the low-voltage detector, refer to **CHAPTER 29 LOW-VOLTAGE DETECTOR**.

### 27.3.4 Reset operation by clock monitor (CLMRES)

When the clock monitor operation is enabled, the main clock is monitored by using the sampling clock (internally oscillated clock:  $f_R$ ). If it is detected that the main clock is stopped, the system is reset and each hardware unit is initialized to a specific status.

After it has been detected that the main clock is stopped, the CPU is placed in the reset status for a specific time (of analog delay), and then it is automatically released from the reset status. After the reset status has been released, the timer for oscillation stabilization does not perform its counting operation, because the main clock is stopped. When watchdog timer 2 that is started by default overflows, the CPU starts program execution on an internally oscillated clock ( $f_R$ ).

The status of each hardware unit during the reset period executed by the reset signal (CLMRES) of the clock monitor operation and after the reset status is released is shown below.

For the reset timing by the clock monitor operation, refer to **Figure 27-5**.

**Table 27-4. Hardware Status During Reset Operation by Clock Monitor**

Item	During Reset	After Reset
Main clock oscillator ( $f_x$ )	Oscillation stops	Oscillation starts <sup>Note</sup>
Subclock oscillator ( $f_{XT}$ )	Oscillation continues	
Internal oscillator	Oscillation stops	Oscillation starts
Peripheral clock ( $f_{XP}$ to $f_{XP}/1,024$ )	Operation stops	Operation starts after securing oscillation stabilization time <sup>Note</sup> .
Internal system clock ( $f_{CLK}$ ), CPU clock ( $f_{CPU}$ )	Operation stops	Operation starts after securing oscillation stabilization time (initialized to $f_x/8$ ). However, if watchdog timer 2 overflows before the CPU execution, operation starts with the internal oscillation clock ( $f_R$ ).
CPU	Initialized	Program execution starts after securing oscillation stabilization time. However, if watchdog timer 2 overflows before the CPU execution, operation starts with the internal oscillation clock ( $f_R$ ).
WDT2	Operation stops (initialized to 0)	Operation starts. WDT2RES is not generated, however, if only watchdog timer 2 overflows before CPU execution.
Internal RAM, expanded internal RAM	Undefined	
I/O lines (ports/alternate-function pins)	High impedance	
On-chip peripheral I/O register	Initialized to specified status, OCDM register retains its value.	
On-chip peripheral functions other than above	Operation stops	Operation can be started after securing oscillation stabilization time <sup>Note</sup> .

**Note** When the main clock starts oscillation after the reset operation by the clock monitor.

**Remark** For details of the clock monitor, refer to **CHAPTER 28 CLOCK MONITOR**.



Figure 27-5. Reset Timing by Clock Monitor

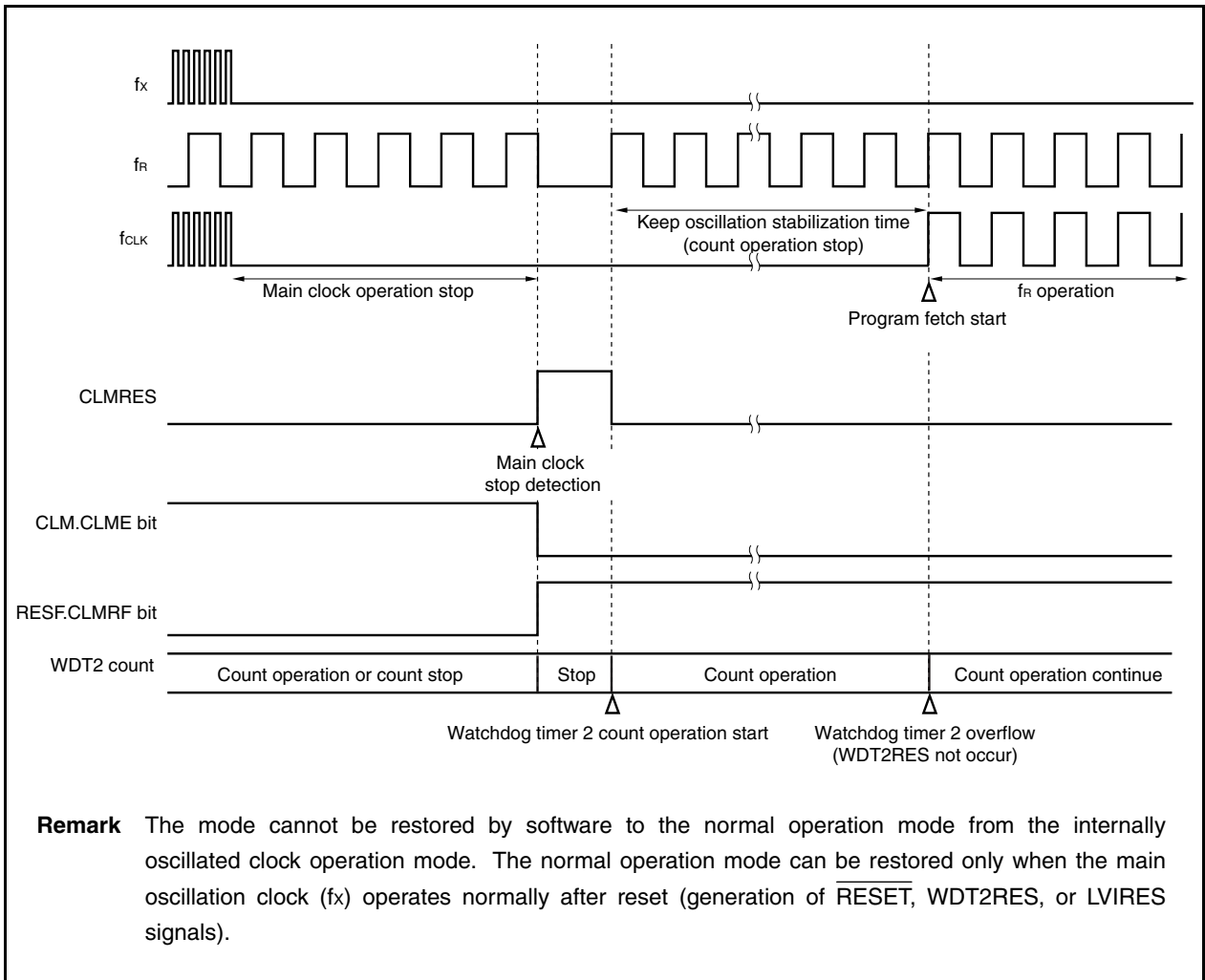

**27.3.5 Operation after reset release**

After the reset is released, the main clock starts oscillation and oscillation stabilization time (OSTS register initial value:  $2^{16}/f_x$ ) is secured, and the CPU starts program execution.

WDT2 immediately begins to operate after a reset has been released using the internal oscillation clock as a source clock.

**Figure 27-6. Operation After Reset Release**

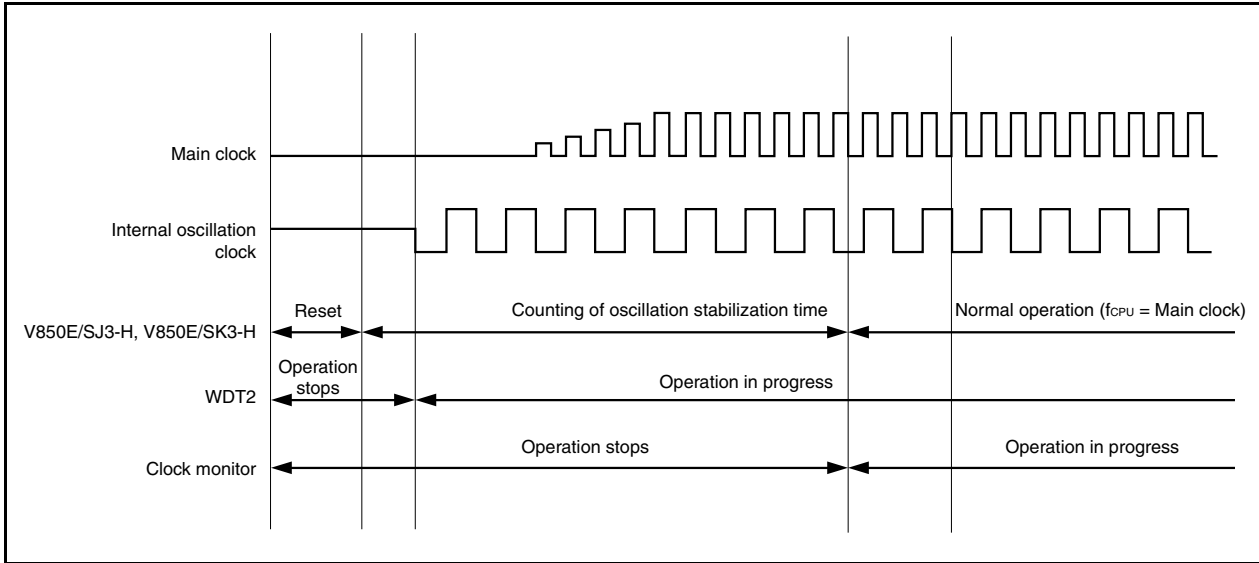

**(1) Emergent operation mode**

If an anomaly occurs in the main clock before oscillation stabilization time is secured, WDT2 overflows before executing the CPU program. At this time, the CPU starts program execution by using the internal oscillation clock as the source clock.

**Figure 27-7. Operation After Reset Release**

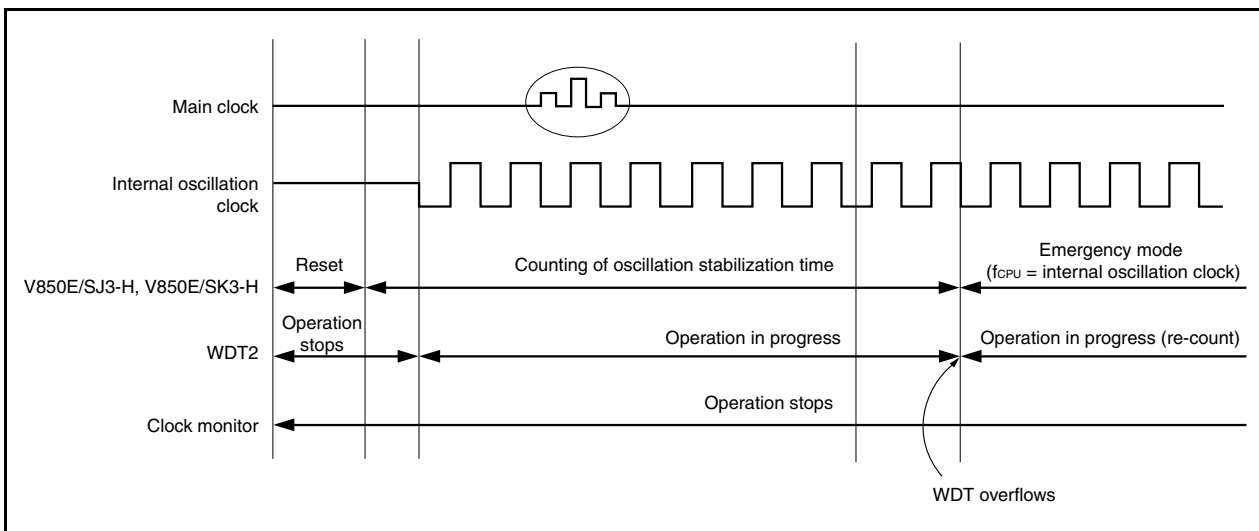

The CPU operation clock states can be checked with the CPU operation clock status register (CCLS).

27.3.6 Reset function operation flow

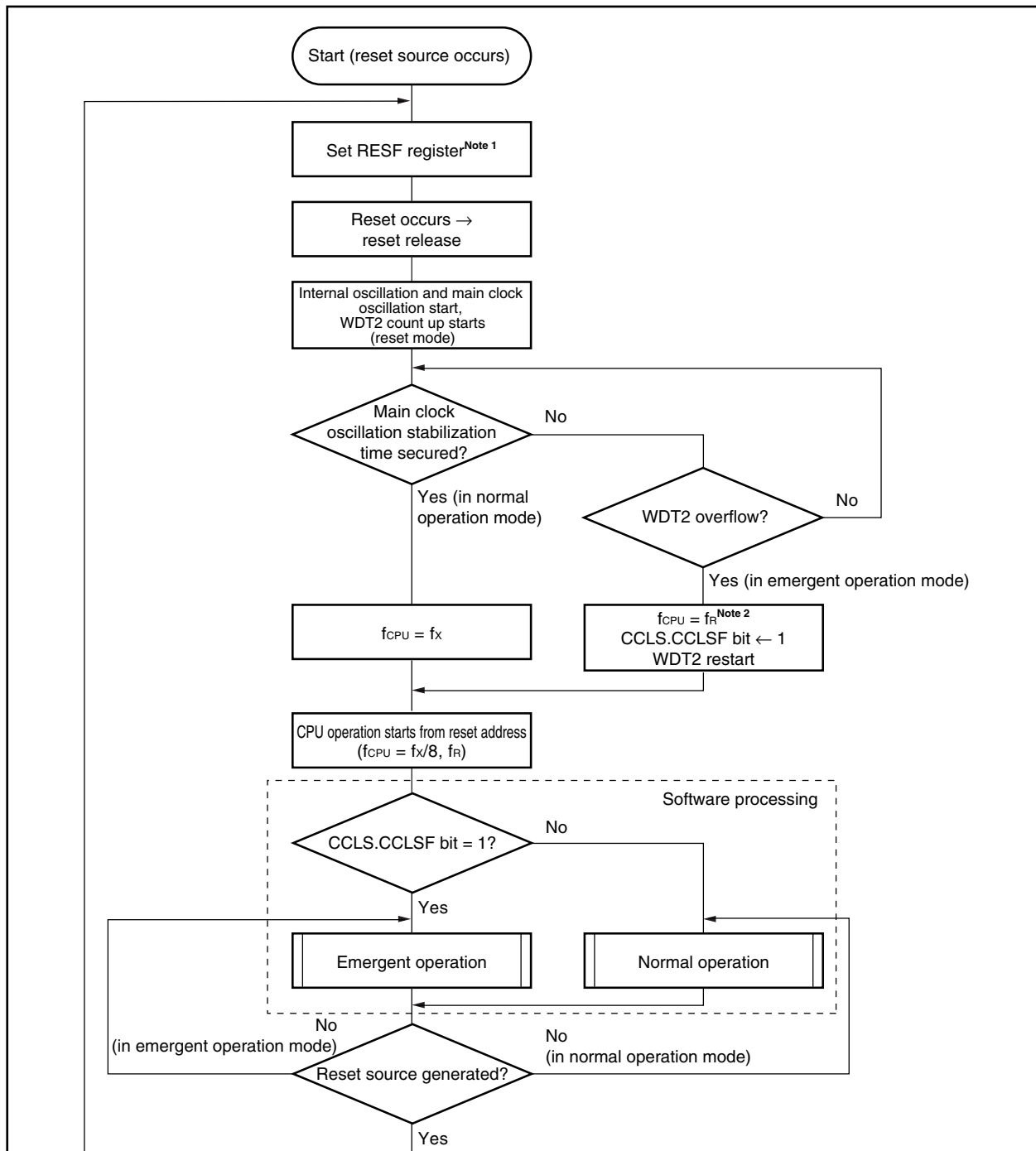

Notes 1. Bit to be set differs depending on the reset source.

Reset Source	WDT2RF Bit	CLMRF Bit	LVIRF Bit
RESET pin	0	0	0
WDT2	1	Value before reset is retained.	Value before reset is retained.
CLM	Value before reset is retained.	1	Value before reset is retained.
LVI	Value before reset is retained.	Value before reset is retained.	1

2. The internal oscillator cannot be stopped.

## CHAPTER 28 CLOCK MONITOR

### 28.1 Functions

The clock monitor samples the main clock by using the internal oscillation clock and generates a reset request signal (CLMRES) when oscillation of the main clock is stopped.

Once the operation of the clock monitor has been enabled by an operation enable flag, it cannot be cleared to 0 by any means other than reset.

When a reset (CLMRES) by the clock monitor occurs, the RESF.CLMRF bit is set. For details on the RESF register, refer to **27.2 Registers to Check Reset Source**.

The clock monitor automatically stops under the following conditions.

- During oscillation stabilization time after STOP mode is released
- When the main clock is stopped (from when the PCC.MCK bit = 1 during subclock operation, until the PCC.CLS bit = 0 during main clock operation)
- When the sampling clock (internal oscillation clock) is stopped
- When the CPU operates with the internal oscillation clock

### 28.2 Configuration

The clock monitor consists of the following hardware.

**Table 28-1. Configuration of Clock Monitor**

Item	Configuration
Control register	Clock monitor mode register (CLM)

**Figure 28-1. Timing of Reset via Clock Monitor**

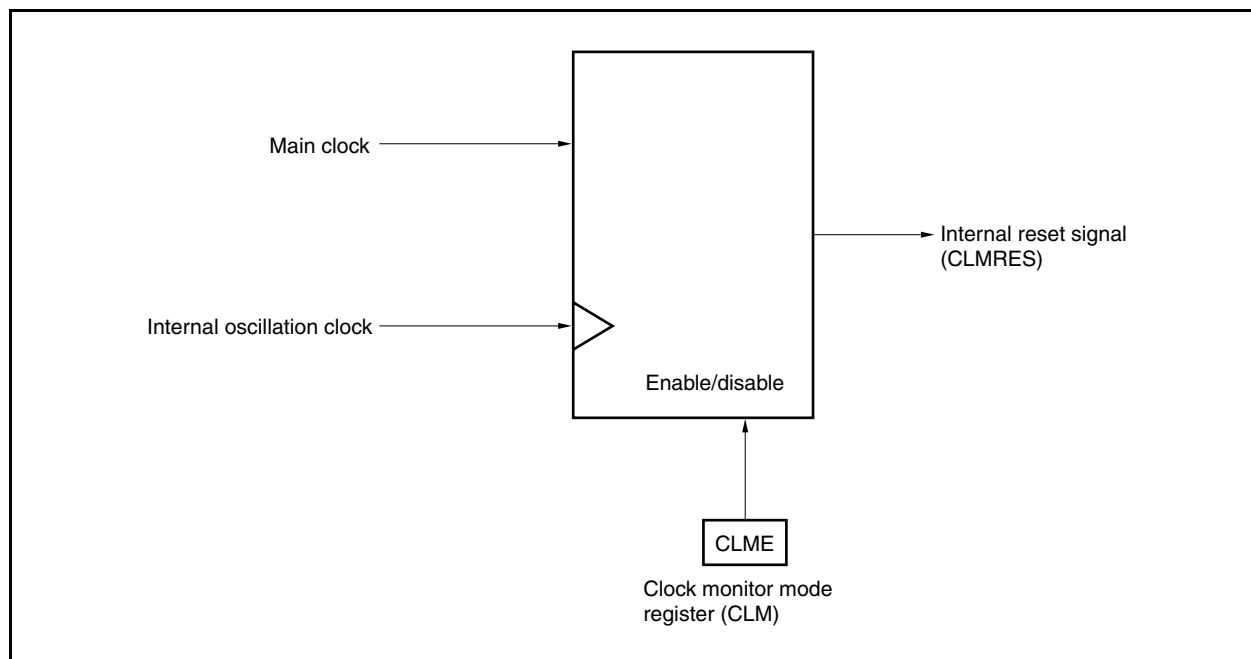

## 28.3 Register

The clock monitor is controlled by the clock monitor mode register (CLM).

### (1) Clock monitor mode register (CLM)

The CLM register is a special register. This can be written only in a special combination of sequences (refer to **3.4.8 Special register**).

This register is used to set the operation mode of the clock monitor.

This register can be read or written in 8-bit or 1-bit units.

Reset sets this register to 00H.

	After reset: 00H	R/W	Address: FFFFF870H					
	7	6	5	4	3	2	1	<0>
CLM	0	0	0	0	0	0	0	CLME
	CLME	Clock monitor operation enable or disable						
	0	Disable clock monitor operation.						
	1	Enable clock monitor operation.						

- Cautions**
1. Once the CLME bit has been set to 1, it cannot be cleared to 0 by any means other than reset.
  2. When a reset by the clock monitor occurs, the CLME bit is cleared to 0 and the RESF.CLMRF bit is set to 1.
  3. Be sure to set bits 1 to 7 to "0".

## 28.4 Operation

This section explains the functions of the clock monitor. The start and stop conditions are as follows.

### <Start condition>

Enabling operation by setting the CLM.CLME bit to 1

### <Stop conditions>

- While oscillation stabilization time is being counted after STOP mode is released
- When the main clock is stopped (from when PCC.MCK bit = 1 during subclock operation to when PCC.CLS bit = 0 during main clock operation)
- When the sampling clock (internal oscillation clock) is stopped
- When the CPU operates using the internal oscillation clock

**Table 28-2. Operation Status of Clock Monitor (When CLM.CLME Bit = 1, During Internal Oscillation Clock Operation)**

CPU Operating Clock	Operation Mode	Status of Main Clock	Status of Internal Oscillation Clock	Status of Clock Monitor
Main clock	HALT mode	Oscillates	Oscillates <sup>Note 1</sup>	Operates <sup>Note 2</sup>
	IDLE1, IDLE2 modes	Oscillates	Oscillates <sup>Note 1</sup>	Operates <sup>Note 2</sup>
	STOP mode	Stops	Oscillates <sup>Note 1</sup>	Stops
Subclock (MCK bit of PCC register = 0)	Sub-IDLE mode	Oscillates	Oscillates <sup>Note 1</sup>	Operates <sup>Note 2</sup>
Subclock (MCK bit of PCC register = 1)	Sub-IDLE mode	Stops	Oscillates <sup>Note 1</sup>	Stops
Internal oscillation clock	–	Stops	Oscillates <sup>Note 3</sup>	Stops
During reset	–	Stops	Stops	Stops

**Notes 1.** The internal oscillator can be stopped by setting the RCM.RSTOP bit to 1.

**2.** The clock monitor is stopped while the internal oscillator is stopped.

**3.** The internal oscillator cannot be stopped by software.

**(1) Operation when main clock oscillation is stopped (CLME bit = 1)**

If oscillation of the main clock is stopped when the CLME bit = 1, an internal reset signal (CLMRES) is generated as shown in Figure 28-2.

**Figure 28-2. Reset Period Due to That Oscillation of Main Clock Is Stopped**

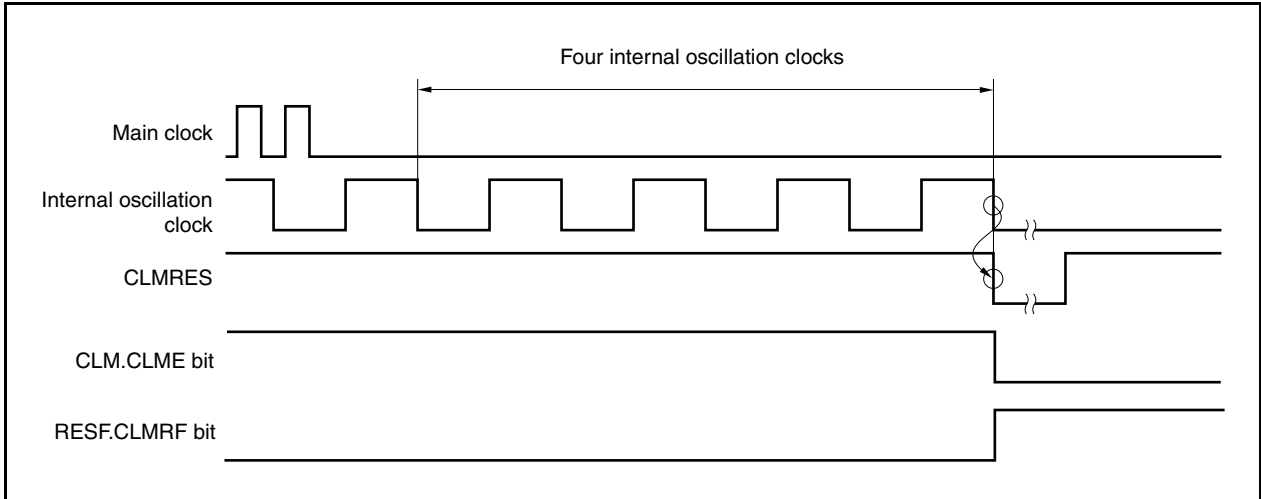

**(2) Clock monitor status after  $\overline{\text{RESET}}$  input**

$\overline{\text{RESET}}$  input clears the CLM.CLME bit to 0 and stops the clock monitor operation. When CLME bit is set to 1 by software at the end of the oscillation stabilization time of the main clock, monitoring is started.

**Figure 28-3. Clock Monitor Status After  $\overline{\text{RESET}}$  Input**

**(CLM.CLME bit = 1 is set after  $\overline{\text{RESET}}$  input and at the end of main clock oscillation stabilization time)**

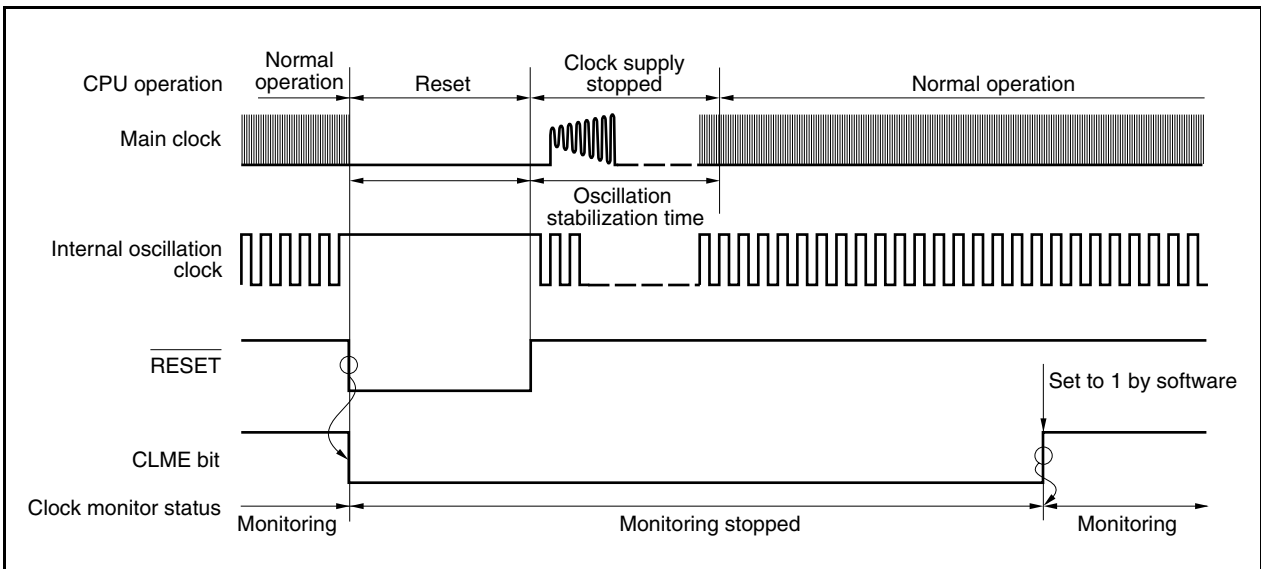

**(3) Operation in STOP mode or after STOP mode is released**

If the STOP mode is set with the CLM.CLME bit = 1, the monitor operation is stopped in the STOP mode and while the oscillation stabilization time is being counted. After the oscillation stabilization time, the monitor operation is automatically started.

**Figure 28-4. Operation in STOP Mode or After STOP Mode Is Released**

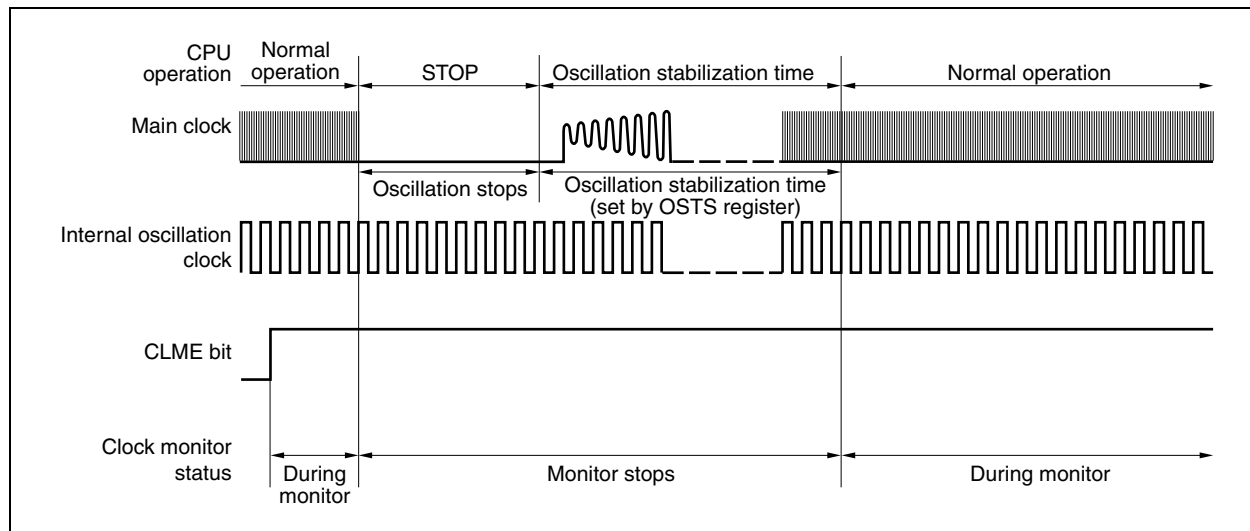

**(4) Operation when main clock is stopped (arbitrary)**

During subclock operation (PCC.CLS bit = 1) or when the main clock is stopped by setting the PCC.MCK bit to 1, the monitor operation is stopped until the main clock operation is started (PCC.CLS bit = 0). The monitor operation is automatically started when the main clock operation is started.

**Figure 28-5. Operation When Main Clock Is Stopped (Arbitrary)**

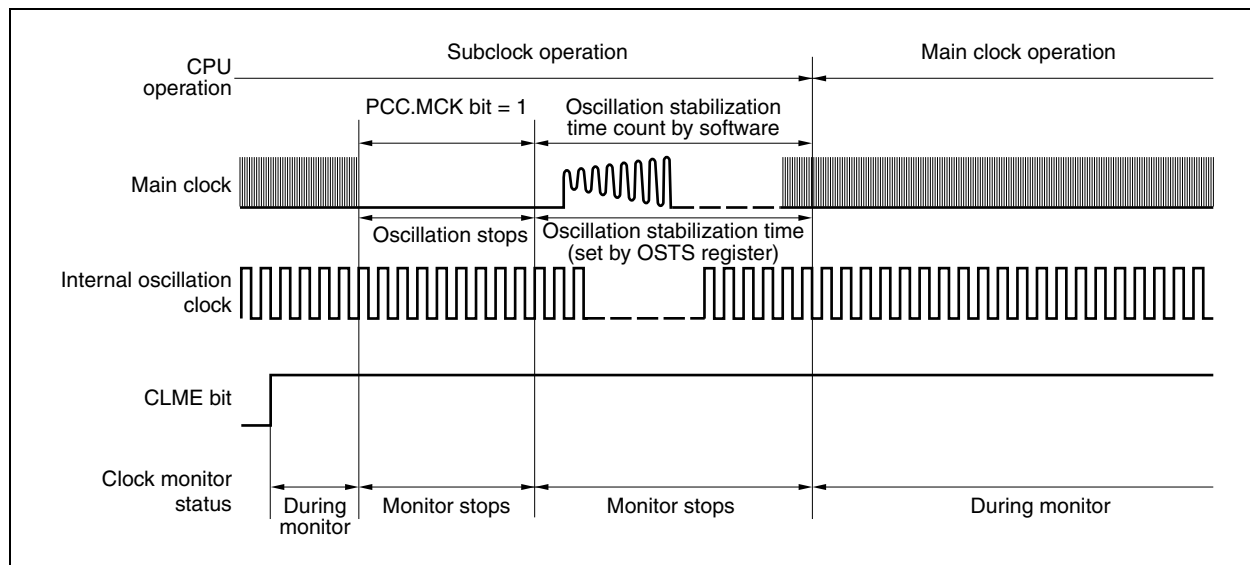

**(5) Operation while CPU is operating on internal oscillation clock (CCLS.CCLS bit = 1)**

The monitor operation is not stopped when the CCLS bit is 1, even if the CLME bit is set to 1.



## CHAPTER 29 LOW-VOLTAGE DETECTOR

### 29.1 Functions

The low-voltage detector (LVI) has the following functions.

- If the interrupt occurrence at low voltage detection is selected, the low-voltage detector compares the supply voltage ( $V_{DD}$ ) and the detected voltage ( $V_{LVI}$ ), and generates an internal interrupt signal (INTLVI) when the supply voltage drops or rises across the detected voltage.
- If the reset occurrence at low voltage detection is selected, the low-voltage detector generates an interrupt reset signal (LVIRES) when the supply voltage ( $V_{DD}$ ) drops across the detected voltage ( $V_{LVI}$ )
- Interrupt or reset signal can be selected by software.

If the low-voltage detector is used to generate a reset signal, the RESF.LVIRF bit is set to 1 when LVIRES signal is generated. For details of RESF register, refer to **CHAPTER 27 RESET FUNCTION**.

### 29.2 Configuration

Figure 29-1 shows the block diagram of the low-voltage detector.

**Figure 29-1. Block Diagram of Low-Voltage Detector**

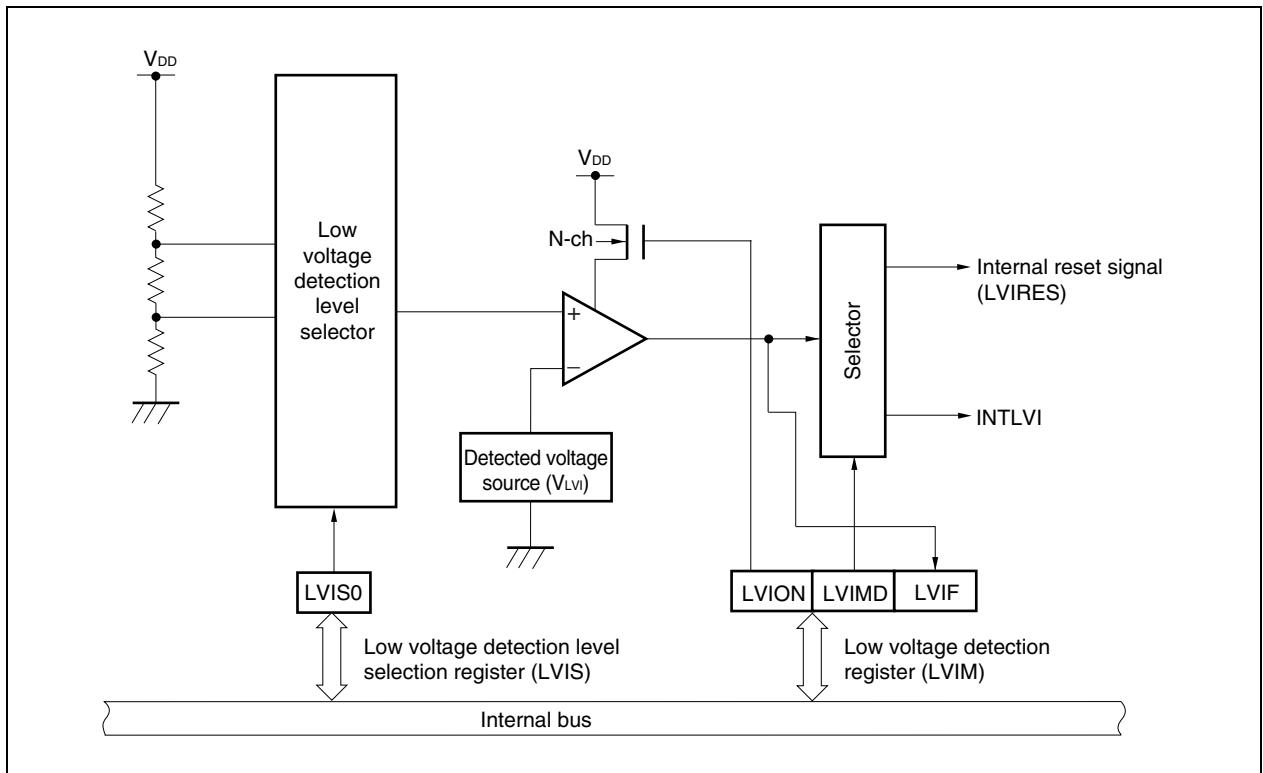

### 29.3 Registers

The low-voltage detector is controlled by the following registers.

- Low voltage detection register (LVIM)
- Low voltage detection level selection register (LVIS)

#### (1) Low voltage detection register (LVIM)

The LVIM register is a special register. This can be written only in the special combination of the sequences (refer to **3.4.8 Special register**).

The LVIM register is used to enable or disable low voltage detection, and to set the operation mode of the low-voltage detector.

This register can be read or written in 8-bit or 1-bit units. However, the LVIF bit is read-only.

After reset: **Note 1** R/W Address: FFFFF890H

	<7>	6	5	4	3	2	<1>	<0>
LVIM	LVION	0	0	0	0	0	LVIMD	LVIF

LVION <sup>Note 2</sup>	Low voltage detection operation enable or disable
0	Disable operation.
1	Enable operation.

LVIMD	Selection of operation mode of low voltage detection
0	Generates interrupt request signal (INTLVI) when the supply voltage drops or rises across the detection voltage value.
1	Generate internal reset signal (LVIRESET) when supply voltage < detected voltage.

LVIF <sup>Note 3</sup>	Low voltage detection flag
0	When supply voltage > detected voltage, or when operation is disabled
1	Supply voltage of connected power supply < detected voltage

- Notes 1.** Reset by low-voltage detection: 82H  
Reset due to other source: 00H
2. Do not change the LVIM.LVION bit from 1 to 0 while the supply voltage ( $V_{DD}$ ) is lower than the detection voltage value ( $V_{LVI}$ ) (LVION.LVIF bit = 1).
  3. After the LVI operation has started (LVION bit = 1) or when INTLVI has occurred, confirm the supply voltage state using the LVIF bit.

- Cautions 1.** When the LVION and LVIMD bits to 1, the low-voltage detector cannot be stopped until the reset request due to other than the low-voltage detection is generated.
2. When the LVION bit is set to 1, the comparator in the LVI circuit starts operating. Wait 0.2 ms or longer by software before checking the voltage at the LVIF bit after the LVION bit is set.
  3. Be sure to clear bits 6 to 2 to “0”.

**(2) Low voltage detection level selection register (LVIS)**

The LVIS register is used to select the level of low voltage to be detected.

This register can be read or written in 8-bit units.

	After reset: <b>Note</b>	R/W	Address: FFFFF891H					
	7	6	5	4	3	2	1	0
LVIS	0	0	0	0	0	0	0	LVIS0

LVIS0	Detection level
0	2.95 V (TYP.)
1	Reserved (setting prohibited)

**Note** Reset by low-voltage detection: Retained  
Reset due to other source: 00H

**Cautions** 1. This register cannot be written until a reset request due to something other than low-voltage detection is generated after the LVIM.LVION and LVIM.LVIMD bits are set to 1.  
2. Be sure to clear bits 7 to 1 to “0”.

**(3) Internal RAM data status register (RAMS)**

The RAMS register is a special register. This can be written only in a special combination of sequences (refer to 3.4.8 Special registers).

This register is a flag register that indicates whether the supply voltage drops below the RAM retention voltage of internal RAM and expanded internal RAM.

This register can be read or written in 8-bit or 1-bit units.

The set/clear conditions for the RAMF bit are shown below.

- Setting conditions: Detection of voltage lower than specified level  
Set by instruction
- Clearing condition: Writing of 0 in specific sequence

	After reset: 01H <sup>Note</sup>	R/W	Address: FFFFF892H					
	7	6	5	4	3	2	1	<0>
RAMS	0	0	0	0	0	0	0	RAMF

RAMF	RAM retention voltage of internal RAM and expanded internal RAM detection
0	Voltage lower than RAM retention voltage is not detected
1	Voltage lower than RAM retention voltage is detected

**Note** This register is reset only when a voltage drop below the RAM retention voltage is detected.

## 29.4 Operation

Depending on the setting of the LVIM.VIMD bit, an interrupt signal (INTLVI) or an internal reset signal (LVIRES) is generated.

How to specify each operation is described below, together with timing charts.

### 29.4.1 To use for internal reset signal (LVIRES)

<To start operation>

- <1> Mask the interrupt of LVI.
- <2> Select the voltage to be detected by using the LVIS.LVIS0 bit.
- <3> Set the LVIM.LVION bit to 1 (to enable operation).
- <4> Insert a wait cycle of 0.2 ms (max.) or more by software.
- <5> By using the LVIM.LVIF bit, check if the supply voltage > detected voltage.
- <6> Set the LVIMD bit to 1 (to generate an internal reset signal (LVIRES)).

**Caution** If LVIMD bit is set to 1, the contents of the LVIM and LVIS registers cannot be changed until a reset request other than LVI is generated.

Figure 29-2. Operation Timing of Low-Voltage Detector (LVIMD Bit = 1)

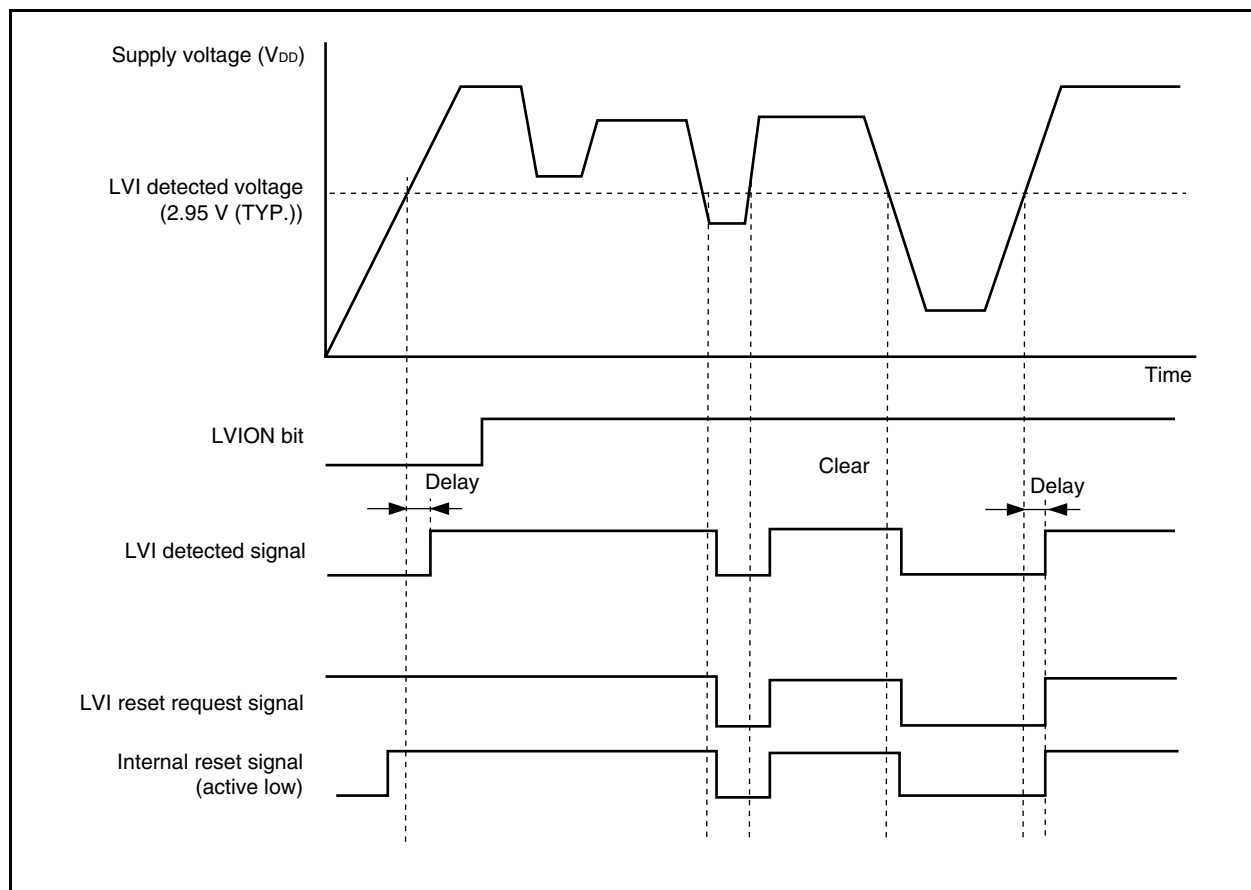

## 29.4.2 To use for interrupt (INTLVI)

<To start operation>

- <1> Mask the interrupt of LVI.
- <2> Select the voltage to be detected by using the LVIS.LVIS0 bit.
- <3> Set the LVIM.LVION bit to 1 (to enable operation).
- <4> Insert a wait cycle of 0.2 ms (max.) or more by software.
- <5> By using the LVIM.LVIF bit, check if the supply voltage > detected voltage.
- <6> Clear the interrupt request flag of LVI.
- <7> Unmask the interrupt of LVI.

<To stop operation>

- <1> By using the LVIM.LVIF bit, check if the supply voltage > detected voltage.
- <2> Clear the LVION bit to 0.

Figure 29-3. Operation Timing of Low-Voltage Detector (LVIMD Bit = 0)

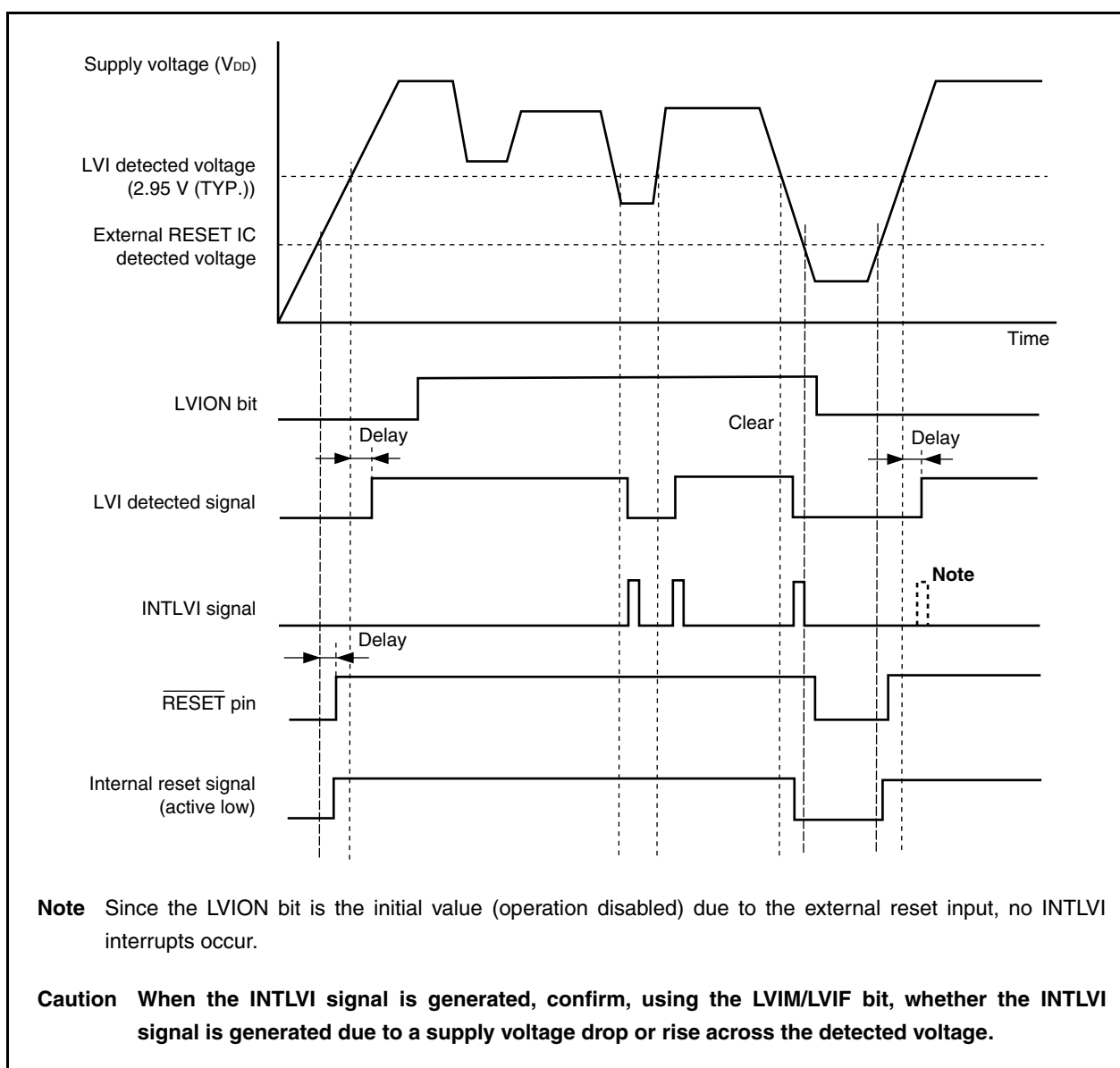

## 29.5 RAM Retention Voltage Detection Operation

The supply voltage and detected voltage are compared. When the supply voltage drops below the detected voltage (including on power application), the RAMS.RAMF bit is set to 1.

**Figure 29-4. Operation Timing of RAM Retention Voltage Detection Function**

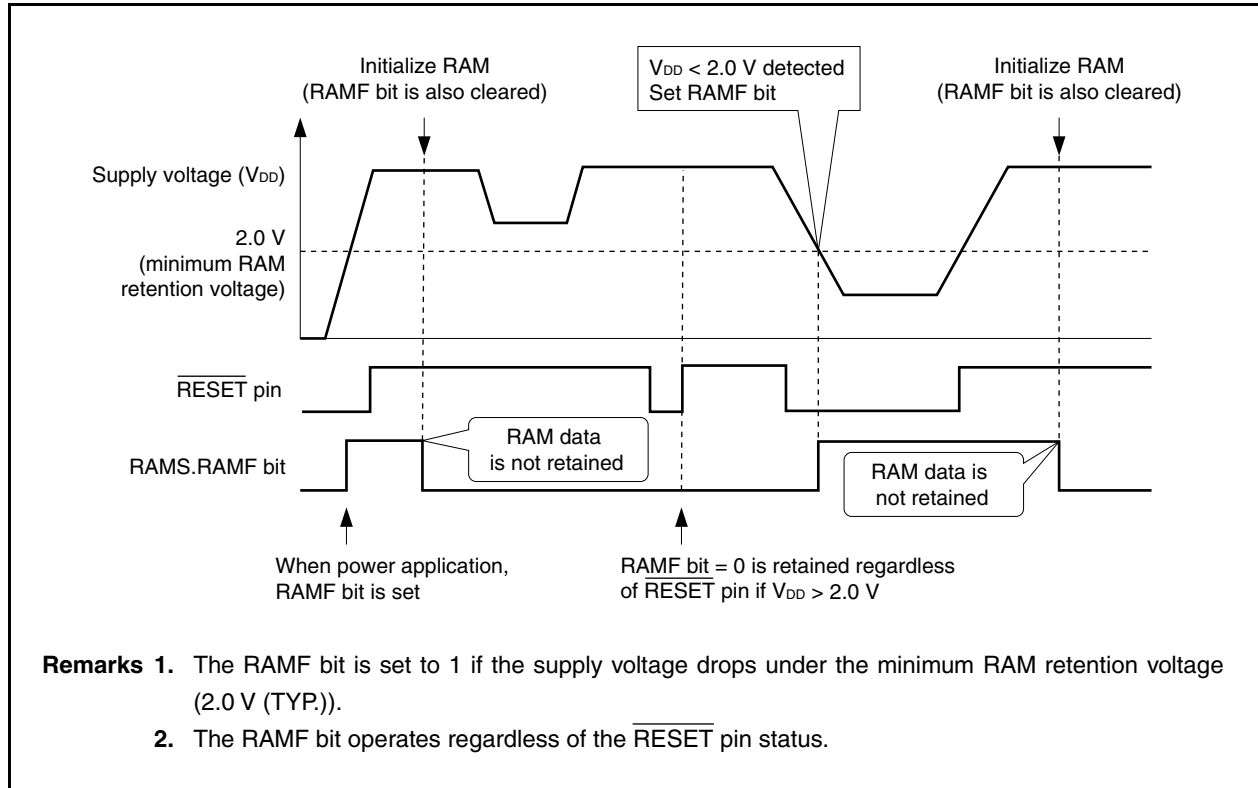

## 29.6 Emulation Function

When an in-circuit emulator is used, the operation of the RAM retention flag (RAMS.RAMF bit) can be pseudo-controlled and emulated by manipulating the PEMU1 register on the debugger.

This register is valid only in the emulation mode. It is invalid in the normal mode.

### (1) Peripheral emulation register 1 (PEMU1)

After reset: 00H	R/W	Address: FFFFF9FEH							
		7	6	5	4	3	2	1	0
PEMU1		0	0	0	0	0	EVARAMIN	0	0
	EVARAMIN	Pseudo specification of RAM retention voltage detection signal							
	0	Do not detect voltage lower than RAM retention voltage.							
	1	Detect voltage lower than RAM retention voltage (set RAMF flag).							

**Caution** This bit is not automatically cleared.

#### [Usage]

When an in-circuit emulator is used, pseudo emulation of RAMF is realized by rewriting this register on the debugger.

- <1> CPU break (CPU operation stops.)
- <2> Set the EVARAMIN bit to 1 by using a register write command.  
By setting the EVARAMIN bit to 1, the RAMF bit is set to 1 on hardware (the internal RAM data is invalid).
- <3> Clear the EVARAMIN bit to 0 by using a register write command again.  
Unless this operation is performed (clearing the EVARAMIN bit to 0), the RAMF bit cannot be cleared to 0 by a CPU operation instruction.
- <4> Run the CPU and resume emulation.

## CHAPTER 30 REGULATOR

### 30.1 Overview

The V850E/SJ3-H and V850E/SK3-H include a regulator to reduce power consumption and noise.

This regulator supplies a stepped-down  $V_{DD}$  power supply voltage to the oscillator block and internal logic circuits (except the A/D converter, D/A converter, and output buffers). The regulator output voltage is set to 2.5 V (TYP.).

Figure 30-1. Regulator

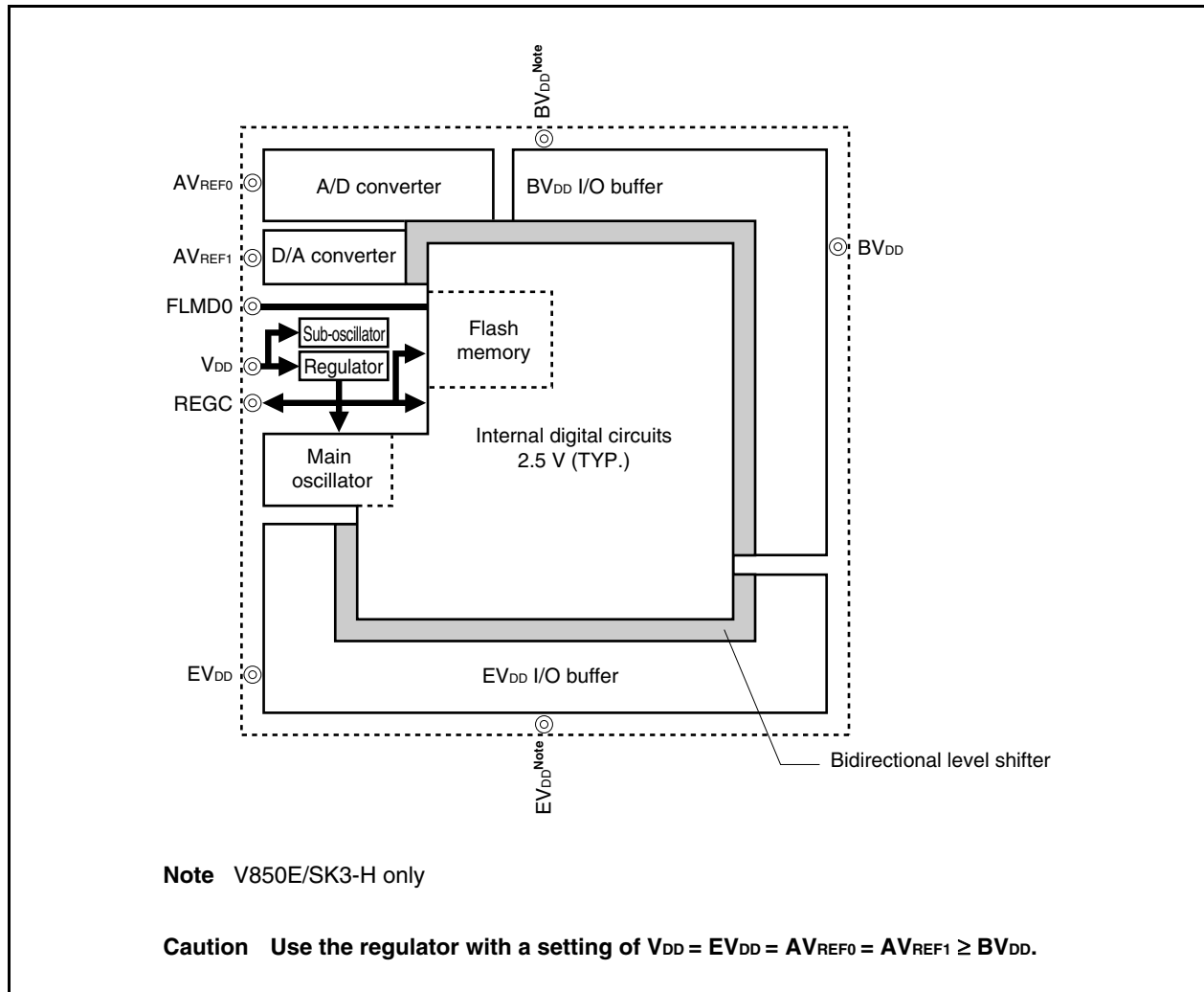



### 30.2 Operation

The regulator of this product always operates in any mode (normal operation mode, HALT mode, IDLE1 mode, IDLE2 mode, STOP mode, subclock operation mode, sub-IDLE mode, or during reset).

Be sure to connect a capacitor ( $4.7 \mu\text{F}$ ) to the REGC pin to stabilize the regulator output.

A diagram of the regulator pin connection method is shown below.

**Figure 30-2. REGC Pin Connection**

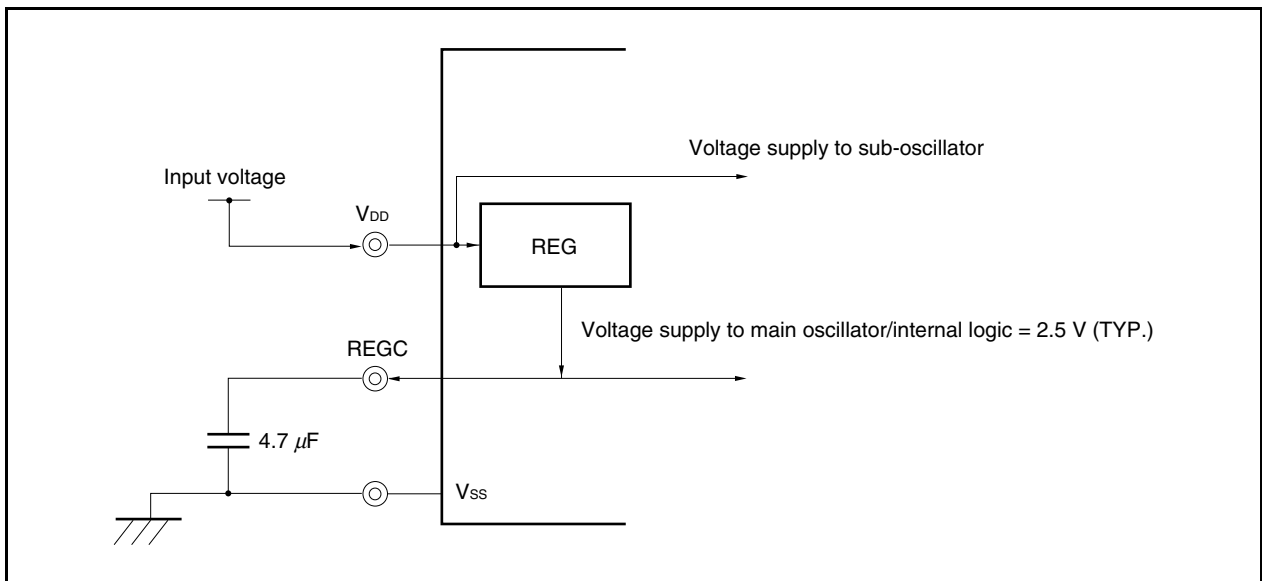

## CHAPTER 31 ROM CORRECTION FUNCTION

### 31.1 Overview

The ROM correction function is used to replace part of the program in the internal ROM with the program of an external memory, internal RAM, or expanded internal RAM.

By using this function, program bugs found in the internal ROM can be corrected.

Up to eight addresses can be specified for correction.

**Figure 31-1. Block Diagram of ROM Correction**

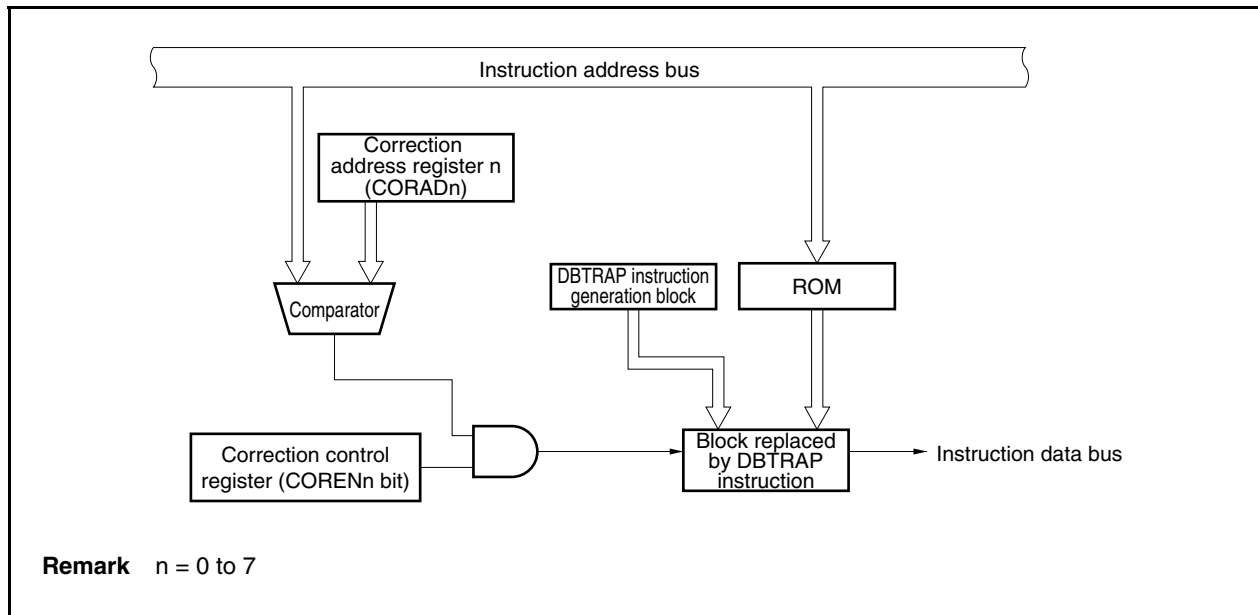

## 31.2 Registers

### (1) Correction address registers 0 to 7 (CORAD0 to CORAD7)

The CORAD0 to CORAD3 registers set the first address of the program to be corrected in the ROM.

The program can be corrected at up to eight places because eight CORADn registers are provided (n = 0 to 7).

The CORADn register can be read or written in 32-bit units.

If the higher 16 bits of the CORADn register are used as the CORADnH register, and the lower 16 bits as the CORADnL register, these registers can be read or written in 16-bit units.

Reset sets these registers to 00000000H.

Because the ROM capacity differs from one product to another, set the correction addresses in the following ranges.

#### (a) V850E/SJ3-H

- |     |  |                       |
|-----|--|-----------------------|
| <R> | • $\mu$ PD70F3931, 70F3932, 70F3933 (512 KB):  | 0000000H to 007FFFFH  |
| <R> | • $\mu$ PD70F3934, 70F3935, 70F3936 (768 KB):  | 0000000H to 00BFFFFH  |
| <R> | • $\mu$ PD70F3937, 70F3938, 70F3939 (1024 KB): | 0000000H to 00FFFFFFH |
|     | • $\mu$ PD70F3474, 70F3475, 70F3476 (1280 KB): | 0000000H to 013FFFFH  |
|     | • $\mu$ PD70F3477, 70F3478, 70F3479 (1536 KB): | 0000000H to 017FFFFH  |

#### (b) V850E/SK3-H

- |  |                       |
|--|-----------------------|
| • $\mu$ PD70F3925, 70F3926, 70F3927 (1024 KB): | 0000000H to 00FFFFFFH |
| • $\mu$ PD70F3486, 70F3487, 70F3488 (1280 KB): | 0000000H to 013FFFFH  |
| • $\mu$ PD70F3480, 70F3481, 70F3482 (1536 KB): | 0000000H to 017FFFFH  |

After reset: 00000000H R/W Address: CORAD0 FFFFF840H,  
 CORAD0L FFFFF840H, CORAD0H FFFFF842H,  
 CORAD1 FFFFF844H,  
 CORAD1L FFFFF844H, CORAD1H FFFFF846H,  
 CORAD2 FFFFF848H,  
 CORAD2L FFFFF848H, CORAD2H FFFFF84AH,  
 CORAD3 FFFFF84CH,  
 CORAD3L FFFFF84CH, CORAD3H FFFFF84EH,  
 CORAD4 FFFFF850H,  
 CORAD4L FFFFF850H, CORAD4H FFFFF852H,  
 CORAD5 FFFFF854H,  
 CORAD5L FFFFF854H, CORAD5H FFFFF856H,  
 CORAD6 FFFFF858H,  
 CORAD6L FFFFF858H, CORAD6H FFFFF85AH,  
 CORAD7 FFFFF85CH,  
 CORAD7L FFFFF85CH, CORAD7H FFFFF85EH

<R>

(a) 512 KB

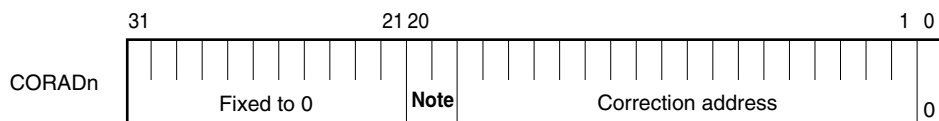

(n = 0 to 7)

<R>

(b) 768 KB, 1024 KB

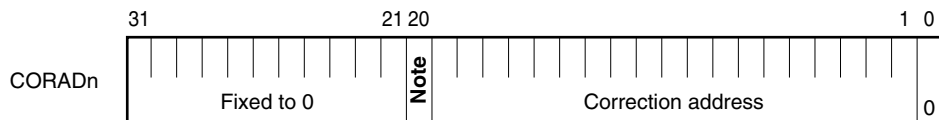

(n = 0 to 7)

(c) 1280 KB, 1536 KB

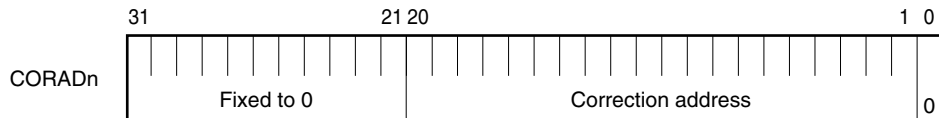

(n = 0 to 7)

**Note** Be sure to set this bit to "0".

**(2) Correction control register (CORCN)**

The CORCN register disables or enables the correction operation at the addresses set in the CORADn register (n = 0 to 7).

Each channel can be enabled or disabled by this register.

This register can be read or written in 8-bit or 1-bit units.

Reset sets this register to 00H.

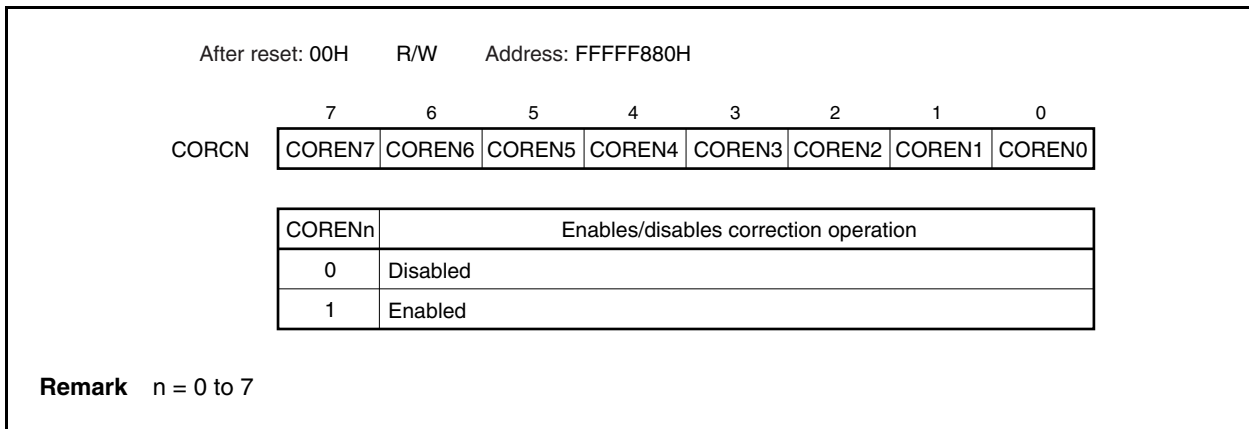

**Table 31-1. Correspondence Between CORCN Register Bits and CORADn Registers**

CORCN Register Bit	Corresponding CORADn Register
COREN7	CORAD7
COREN6	CORAD6
COREN5	CORAD5
COREN4	CORAD4
COREN3	CORAD3
COREN2	CORAD2
COREN1	CORAD1
COREN0	CORAD0

### 31.3 ROM Correction Operation and Program Flow

- <1> If the address to be corrected and the fetch address of the internal ROM match, the fetch code is replaced by the DBTRAP instruction.
- <2> When the DBTRAP instruction is executed, execution branches to address 00000060H.
- <3> Software processing after branching causes the result of ROM correction to be judged (the fetch address and ROM correction operation are confirmed) and execution to branch to the correction software.
- <4> After the correction software has been executed, the return address is set, and return processing is started by the DBRET instruction.

**Caution** The software that performs <3> and <4> must be executed in the internal ROM, internal RAM, external memory, or expanded internal RAM.

Figure 31-2. ROM Correction Operation and Program Flow

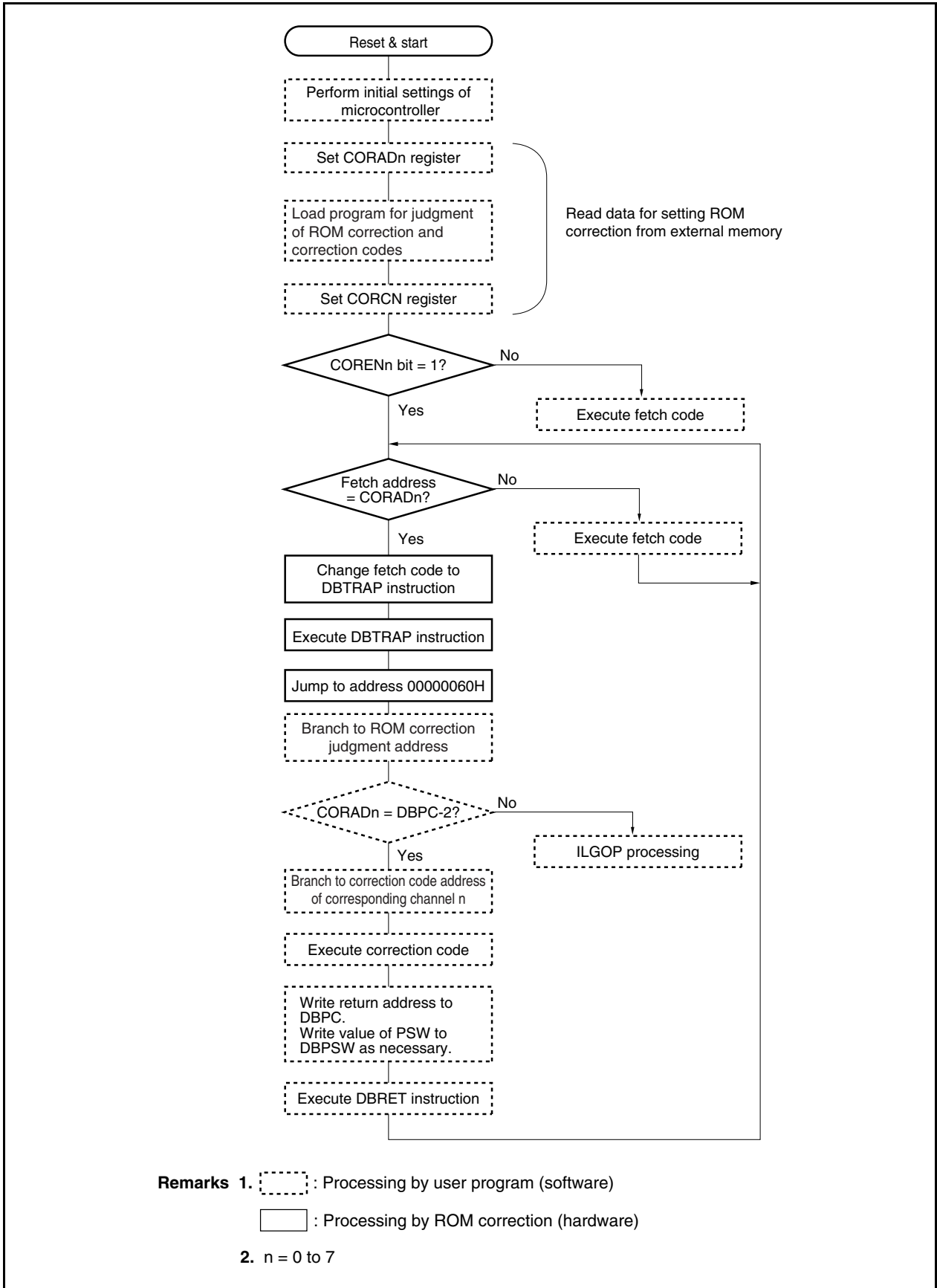

- Remarks 1.**  : Processing by user program (software)  
 : Processing by ROM correction (hardware)
- 2.** n = 0 to 7

### 31.4 Cautions

- (1) When setting an address to be corrected in the CORADn register, clear the higher bits to 0 in accordance with the capacity of the internal ROM.
- (2) The ROM correction function cannot be used to correct data in the internal ROM. It can only be used to correct instruction codes. If ROM correction is used to correct data, that data is replaced with a DBTRAP instruction code.
- (3) ROM correction is not performed in regards to the ROM code before writing in the CORCNn register ends.
- (4) After executing a DBTRAP instruction, the PSW.NP, EP, and DI bits are set to 111, and interrupt/exception cannot be acknowledged. After executing a DBTRAP instruction, change the PSW register value as required.
- (5) The DBPC and DBPSW registers can be accessed while DBTRAP instructions are being executed.
- (6) If the addresses of the instructions executed immediately after the CORCNn register setting (enabled) are set as the correction addresses, normal operation may not be obtained (DBTRAP is not generated).



## CHAPTER 32 FLASH MEMORY

The V850E/SJ3-H and V850E/SK3-H incorporate flash memory.

### (1) V850E/SJ3-H

- <R> •  $\mu$ PD70F3931, 70F3932, 70F3933: 512 KB flash memory
- <R> •  $\mu$ PD70F3934, 70F3935, 70F3936: 768 KB flash memory
- <R> •  $\mu$ PD70F3937, 70F3938, 70F3939: 1024 KB flash memory
- $\mu$ PD70F3474, 70F3475, 70F3476: 1280 KB flash memory
- $\mu$ PD70F3477, 70F3478, 70F3479: 1536 KB flash memory

### (2) V850E/SK3-H

- $\mu$ PD70F3925, 70F3926, 70F3927: 1024 KB flash memory
- $\mu$ PD70F3486, 70F3487, 70F3488: 1280 KB flash memory
- $\mu$ PD70F3480, 70F3481, 70F3482: 1536 KB flash memory

Flash memory versions offer the following advantages for development environments and mass production applications.

- For altering software after the V850E/SJ3-H or V850E/SK3-H is soldered onto the target system.
- For data adjustment when starting mass production.
- For differentiating software according to the specification in small scale production of various models.
- For facilitating inventory management.
- For updating software after shipment.

### 32.1 Features

- <R>  4-byte/1-clock access (when instruction is fetched)
- Capacity: 1536/1280/1024/768/512 KB
- Write voltage: Erase/write with a single power supply
- Rewriting method
  - Rewriting by communication with dedicated flash memory programmer via serial interface (on-board/off-board programming)
  - Rewriting flash memory by user program (self programming)
- Flash memory write prohibit function supported (security function)
- Safe rewriting of entire flash memory area by self programming using boot swap function
- Interrupts can be acknowledged during self programming.

### 32.2 Memory Configuration

The internal flash memory areas of the V850E/SJ3-H and V850E/SK3-H are divided into 4 KB blocks and can be programmed/erased in block units. All or some of the blocks can also be erased at once.

When the boot swap function is used, the boot swap cluster selected by the setting value of a boot block cluster is replaced by another boot swap cluster of the same size located at the addresses higher than those of the cluster. For details of the boot swap function, see **32.5 Rewriting by Self Programming**.

Figure 32-1. Flash Memory Mapping (1/2)

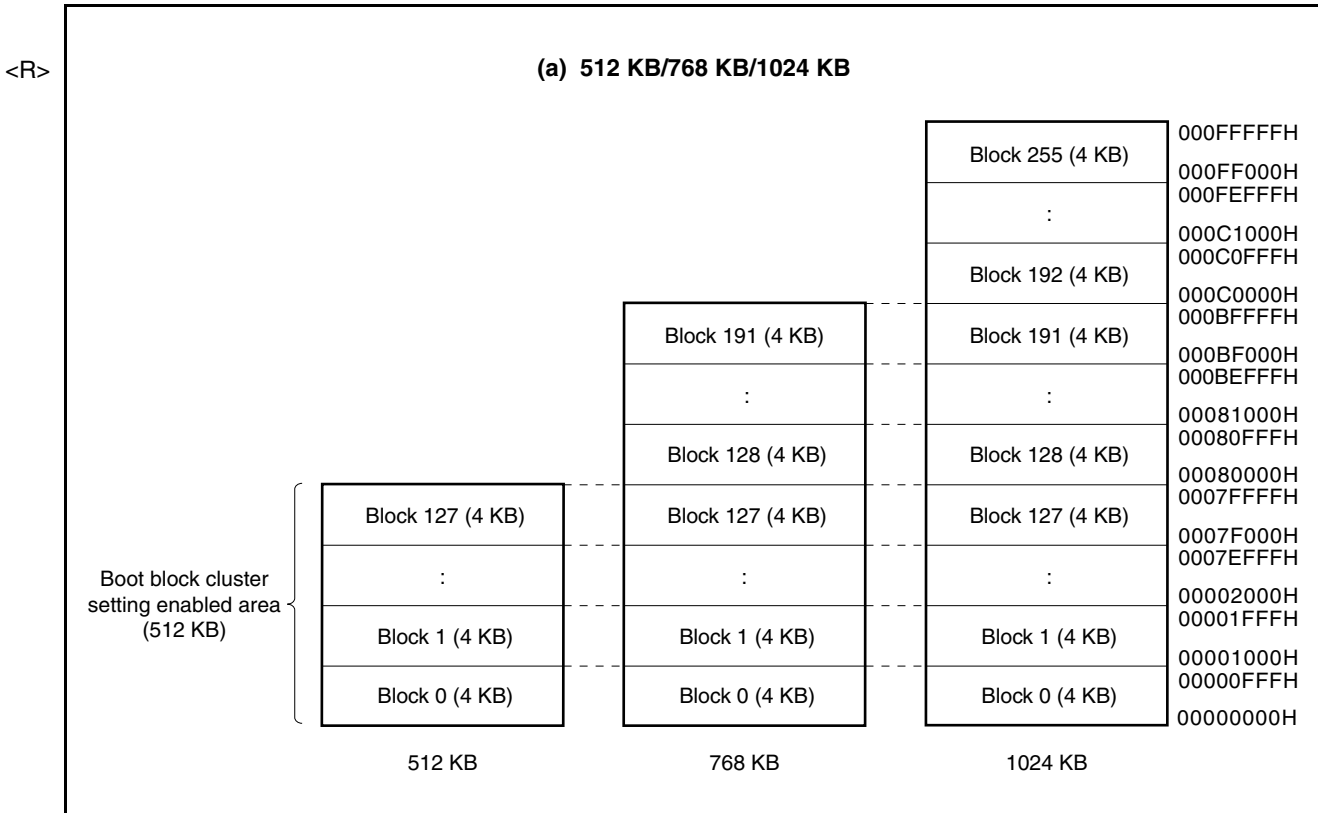
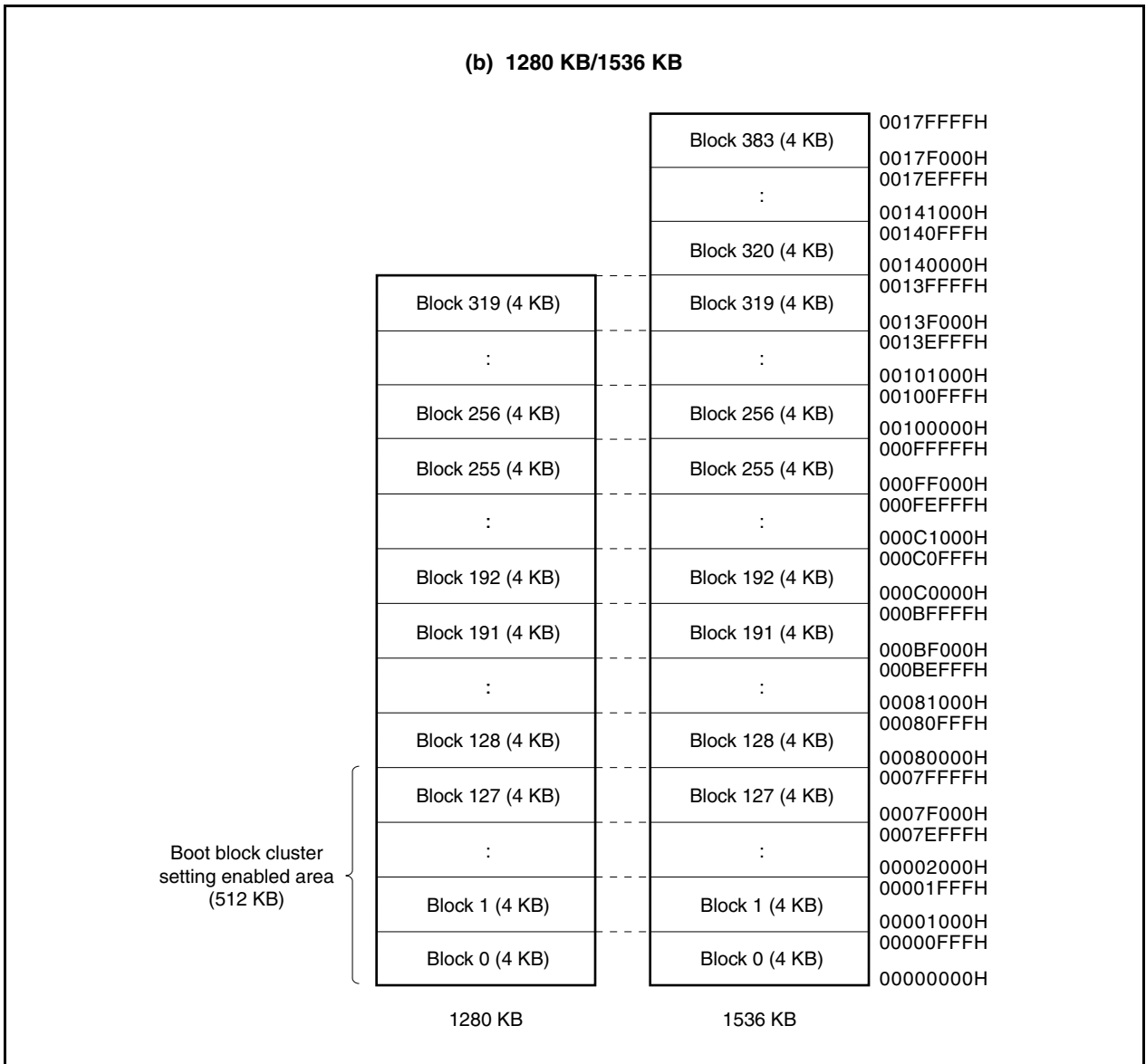

Figure 32-1. Flash Memory Mapping (2/2)



### 32.3 Functional Outline

The internal flash memories of the V850E/SJ3-H and V850E/SK3-H can be rewritten by using the rewrite function of the dedicated flash memory programmer, regardless of whether the V850E/SJ3-H or V850E/SK3-H has already been mounted on the target system or not (off-board/on-board programming).

In addition, a security function that prohibits rewriting the user program written to the internal flash memory is also supported, so that the program cannot be changed by an unauthorized person.

The rewrite function using the user program (self programming) is ideal for an application where it is assumed that the program is changed after production/shipment of the target system. A boot swap function that rewrites the entire flash memory area safely is also supported. In addition, interrupt servicing is supported during self programming, so that the flash memory can be rewritten under various conditions, such as while communicating with an external device.

**Table 32-1. Rewrite Method**

Rewrite Method	Functional Outline	Operation Mode
On-board programming	Flash memory can be rewritten after the device is mounted on the target system, by using a dedicated flash memory programmer.	Flash memory programming mode
Off-board programming	Flash memory can be rewritten before the device is mounted on the target system, by using a dedicated flash memory programmer and a dedicated program adapter board (FA series).	
Self programming	Flash memory can be rewritten by executing a user program that has been written to the flash memory in advance by means of off-board/on-board programming. (During self-programming, instructions cannot be fetched from or data access cannot be made to the internal flash memory area. Therefore, the rewrite program must be transferred to the internal RAM or external memory in advance.)	Normal operation mode

**Remark** The FA series is a product of Naito Densai Machida Mfg. Co., Ltd.

Table 32-2. Basic Functions

Function	Functional Outline	Support (√: Supported, ×: Not supported)	
		On-Board/Off-Board Programming	Self Programming
Blank check	The erasure status of the entire memory is checked.	√	√
Chip erasure	The contents of the entire memory area are erased all at once.	√	× <sup>Note</sup>
Block erasure	The contents of specified memory blocks are erased.	√	√
Program	Writing to specified addresses, and a verify check to see if write level is secured are performed.	√	√
Verify/checksum	Data read from the flash memory is compared with data transferred from the flash memory programmer.	√	× (Can be read by user program)
Read	Data written to the flash memory is read.	√	×
Security setting	Use of the chip erase command, block erase command, program command, and read command can be prohibited, and rewriting of the boot block cluster can be prohibited.	√	× (Supported only when setting is changed from enable to disable)

**Note** This is possible by selecting the entire memory area for the block erase function.

The following table lists the security functions. The chip erase command prohibit, block erase command prohibit, program command prohibit, read command prohibit, and rewriting boot block cluster prohibit functions are enabled by default after shipment, and security can be set by rewriting via on-board/off-board programming. Each security function can be used in combination with the others at the same time.

Table 32-3. Security Functions

Function	Functional Outline
Chip erase command prohibit	Execution of chip erase and block erase commands on all of the blocks is prohibited. Once prohibition is set, all of the settings of prohibition cannot be initialized because the chip erase command cannot be executed.
Block erase command prohibit	Execution of a block erase command on all of the blocks is prohibited. Setting of prohibition can be initialized by execution of a chip erase command.
Program command prohibit	Execution of program and block erase commands on all of the blocks is prohibited. Setting of prohibition can be initialized by execution of the chip erase command.
Read command prohibit	Execution of a read command on all of the blocks is prohibited. Setting of the prohibition can be initialized by execution of the chip erase command.
Rewriting boot block cluster prohibit	Boot block clusters in block 0 to the specified block can be protected. Rewriting (erasing and writing) the protected boot block clusters is disabled. Even if the chip erase command is executed, setting of prohibition cannot be initialized. The maximum number of specifiable blocks is 127.

Table 32-4. Security Setting

Function	Erase, Write, Read Operations When Each Security Is Set (√: Executable, ×: Not Executable, -: Not Supported)		Notes on Security Setting	
	On-Board/ Off-Board Programming	Self Programming	On-Board/ Off-Board Programming	Self Programming
Chip erase command prohibit	Chip erase command: × Block erase command: × Program command: √ <sup>Note 1</sup> Read command: √	Chip erasure: – Block erasure (FlashBlockErase): √ Write (FlashWordWrite): √ Read (FlashWordRead): √	Setting of prohibition cannot be initialized.	Supported only when setting is changed from enable to disable
Block erase command prohibit	Chip erase command: √ Block erase command: × Program command: √ Read command: √	Chip erasure: – Block erasure (FlashBlockErase): √ Write (FlashWordWrite): √ Read (FlashWordRead): √	Setting of prohibition can be initialized by chip erase command.	
Program command prohibit	Chip erase command: √ Block erase command: × Program command: × Read command: √	Chip erasure: – Block erasure (FlashBlockErase): √ Write (FlashWordWrite): √ Read (FlashWordRead): √	Setting of prohibition can be initialized by chip erase command.	
Read command prohibit	Chip erase command: √ Block erase command: √ Program command: √ Read command: ×	Chip erasure: – Block erasure (FlashBlockErase): √ Write (FlashWordWrite): √ Read (FlashWordRead): √	Setting of prohibition can be initialized by chip erase command.	
Boot block cluster rewrite prohibit	Chip erase command: × Block erase command: × <sup>Note 2</sup> Program command: × <sup>Note 2</sup> Read command: √	Chip erasure: – Block erasure (FlashBlockErase): × <sup>Note 2</sup> Write (FlashWordWrite): × <sup>Note 2</sup> Read (FlashWordRead): √	Setting of prohibition cannot be initialized.	Supported only when setting is changed from enable to disable <sup>Note 3</sup>

**Notes 1.** In this case, since the erase command is invalid, data different from the data already written in the flash memory cannot be written.

**2.** Executable except in boot block cluster.

**3.** The boot block cluster rewrite prohibit function becomes effective after the reset input.

### 32.4 Rewriting by Dedicated Flash Memory Programmer

The flash memory can be rewritten by using a dedicated flash memory programmer after the V850E/SJ3-H or V850E/SK3-H is mounted on the target system (on-board programming). The flash memory can also be rewritten before the device is mounted on the target system (off-board programming) by using a dedicated program adapter (FA series).

#### 32.4.1 Programming environment

The following shows the environment required for writing programs to the flash memories of the V850E/SJ3-H and V850E/SK3-H.

**Figure 32-2. Environment Required for Writing Programs to Flash Memory**

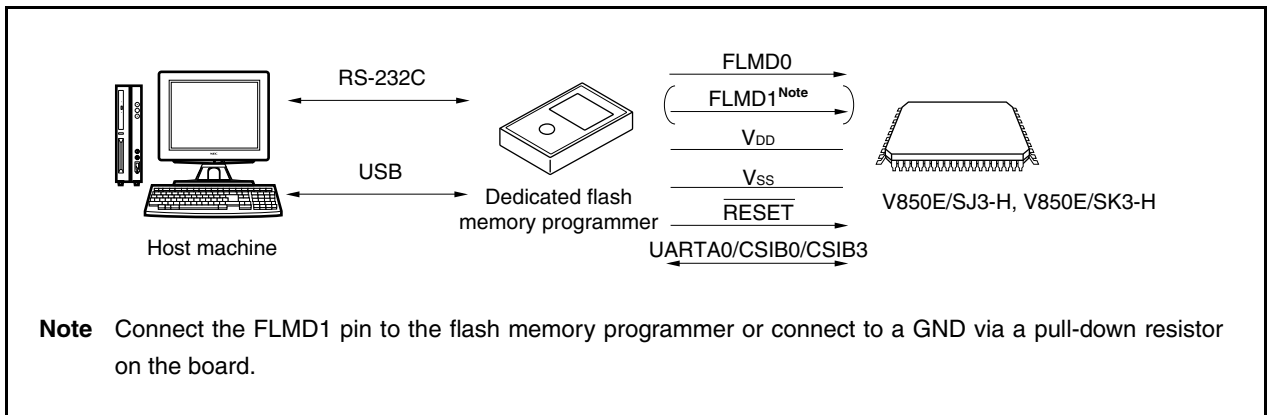

A host machine is required for controlling the dedicated flash memory programmer.

UARTA0, CSIB0, or CSIB3 is used for the interface between the dedicated flash memory programmer and the V850E/SJ3-H and V850E/SK3-H to perform writing, erasing, etc. A dedicated program adapter (FA series) required for off-board writing.

**Remark** The FA series is a product of Naito Densai Machida Mfg. Co., Ltd.

### 32.4.2 Communication mode

Communication between the dedicated flash memory programmer and the V850E/SJ3-H/V850E/SK3-H is performed by serial communication using the UARTA0, CSIB0, or CSIB3 interfaces of the V850E/SJ3-H/V850E/SK3-H.

#### (1) UARTA0

- <R> • Transfer rate: 9,600 to 500,000 bps

Figure 32-3. Communication with Dedicated Flash Memory Programmer (UARTA0)

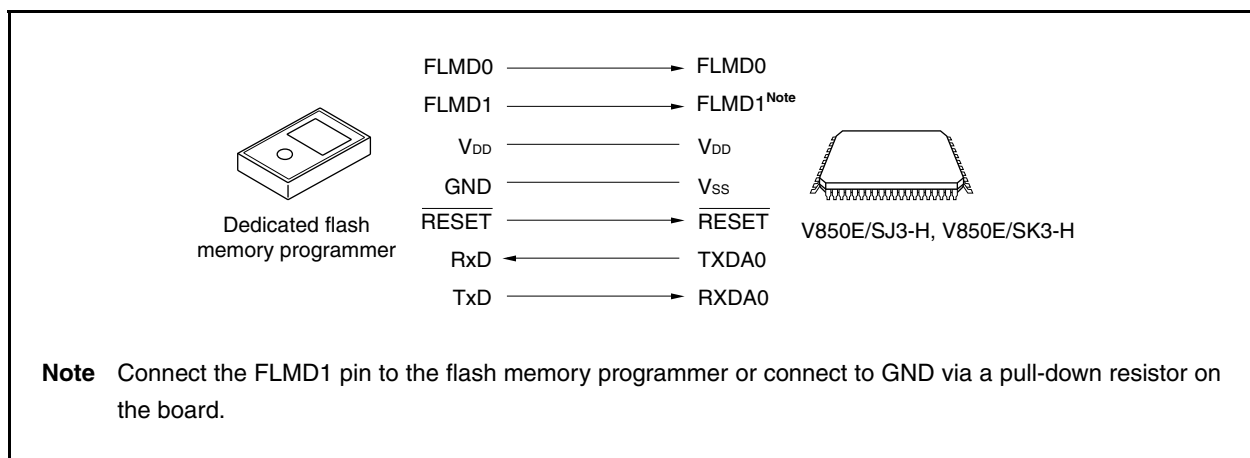

#### (2) CSIB0, CSIB3

- <R> • Serial clock: 2.4 kHz to 5 MHz (MSB first)

Figure 32-4. Communication with Dedicated Flash Memory Programmer (CSIB0, CSIB3)

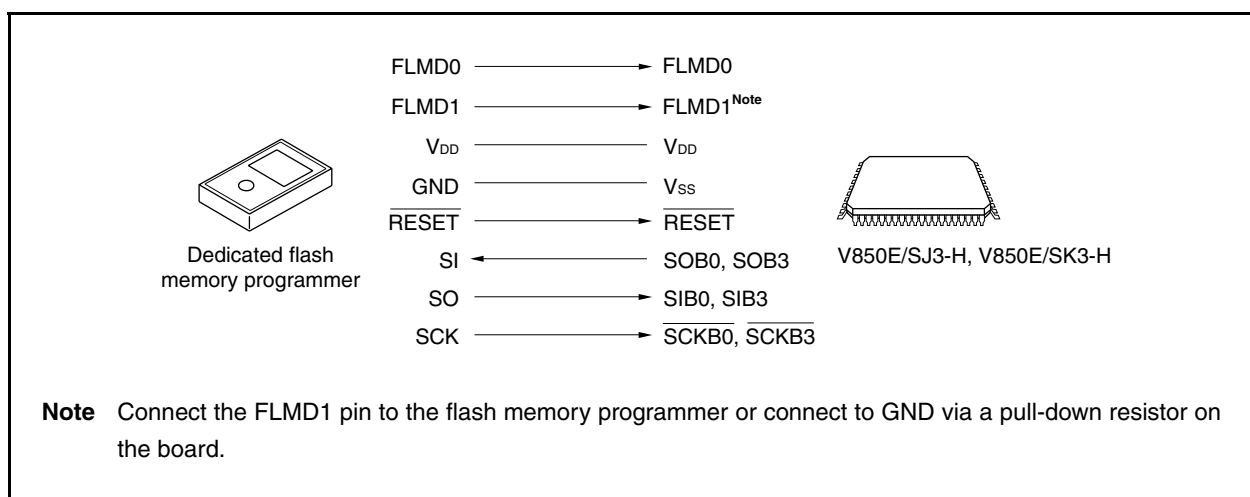



(3) CSIB0 + HS, CSIB3 + HS

- Serial clock: 2.4 kHz to 5 MHz (MSB first)

Figure 32-5. Communication with Dedicated Flash Memory Programmer (CSIB0 + HS, CSIB3 + HS)

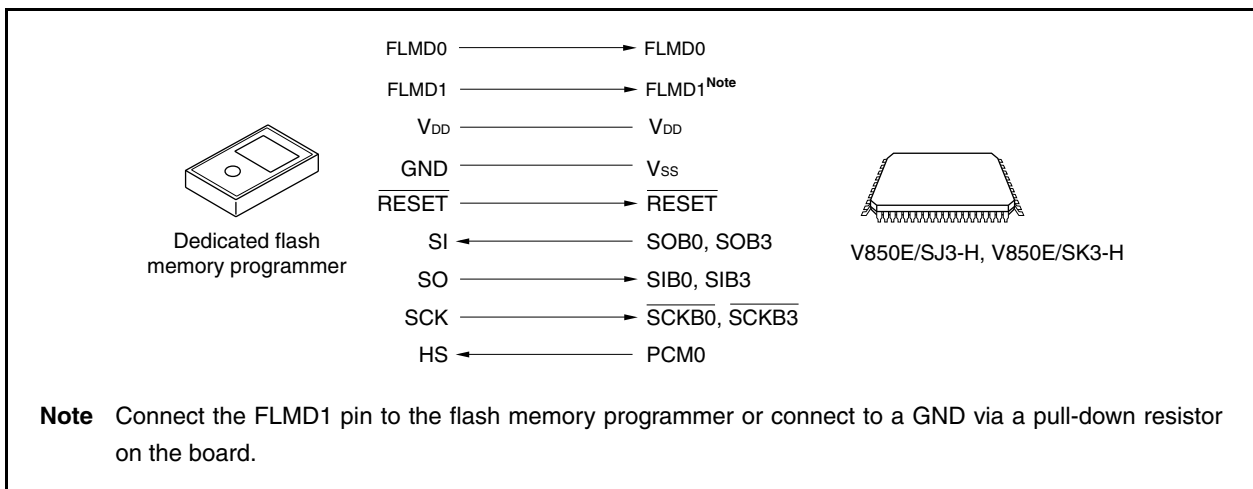

The dedicated flash memory programmer outputs the transfer clock, and the V850E/SJ3-H and V850E/SK3-H operates as a slave.

- When the PG-FP5 is used as the dedicated flash memory programmer, it generates the following signals to the V850E/SJ3-H and V850E/SK3-H. For details, refer to the **PG-FP5 User's Manual (U18865E)**.

Table 32-5. Signal Connections of Dedicated Flash Memory Programmer (PG-FP5)

PG-FP5			V850E/SJ3-H, V850E/SK3-H	Processing for Connection		
Signal Name	I/O	Pin Function	Pin Name	UARTA0	CSIB0, CSIB3	CSIB0 + HS, CSIB3 + HS
FLMD0	Output	Write enable/disable	FLMD0	○	○	○
FLMD1	Output	Write enable/disable	FLMD1	○ <sup>Note 1</sup>	○ <sup>Note 1</sup>	○ <sup>Note 1</sup>
VDD	–	V <sub>DD</sub> voltage generation/voltage monitor	V <sub>DD</sub>	○	○	○
GND	–	Ground	V <sub>SS</sub>	○	○	○
CLK	Output	Clock output to V850E/SJ3-H, V850E/SK3-H	X1, X2	× <sup>Note 2</sup>	× <sup>Note 2</sup>	× <sup>Note 2</sup>
RESET	Output	Reset signal	RESET	○	○	○
SI/RxD	Input	Receive signal	SOB0, SOB3/TXDA0	○	○	○
SO/TxD	Output	Transmit signal	SIB0, SIB3/RXDA0	○	○	○
SCK	Output	Transfer clock	SCKB0, SCKB3	×	○	○
HS	Input	Handshake signal for CSIB0 + HS, CSIB3 + HS communication	PCM0	×	×	○

- Notes 1.** Wire these pins as shown in Figures 32-6 and 32-7, or connect them to GND via pull-down resistor on board.
- 2.** Clock cannot be supplied via the CLK pin of the flash memory programmer. Create an oscillator on board and supply the clock.

**Remark** ○: Must be connected.  
×: Does not have to be connected.

**Table 32-6. Wiring of V850E/SJ3-H, V850E/SK3-H Flash Writing Adapters  
(FA-144GJ-GAE-B, FA-176GM-GAR-B) (1/2)**

Flash Memory Programmer (PG-FP5) Connection Pin			Name of FA Board Pin	CSIB0 + HS Used			CSIB0 Used			UARTA0 Used		
Signal Name	I/O	Pin Function		Pin Name	Pin No.		Pin Name	Pin No.		Pin Name	Pin No.	
					SJ3-H	SK3-H		SJ3-H	SK3-H		SJ3-H	SK3-H
				GJ	GM	GJ	GM	GJ	GM			
SI/RxD	Input	Receive signal	SI	P41/SOB0/ SCL01	23	25	P41/SOB0/ SCL01	23	25	P30/TXDA0/ SOB4	25	30
SO/TxD	Output	Transmit signal	SO	P40/SIB0/ SDA01	22	24	P40/SIB0/ SDA01	22	24	P31/RXDA0 /INTP7/SIB4	26	31
SCK	Output	Transfer clock	SCK	P42/ $\overline{\text{SCKB0}}$ / INTP2	24	26	P42/ $\overline{\text{SCKB0}}$ / INTP2	24	26	Not needed	–	–
CLK	Output	Clock to V850E/SJ3-H, V850E/SK3-H	X1	Not needed	–	–	Not needed	–	–	Not needed	–	–
			X2	Not needed	–	–	Not needed	–	–	Not needed	–	–
/RESET	Output	Reset signal	/RESET	$\overline{\text{RESET}}$	14	16	$\overline{\text{RESET}}$	14	16	$\overline{\text{RESET}}$	14	16
FLMD0	Output	Write voltage	FLMD0	FLMD0	8	10	FLMD0	8	10	FLMD0	8	10
FLMD1	Output	Write voltage	FLMD1	PLD5/AD5/ FLMD1	110	134	PLD5/AD5/ FLMD1	110	134	PLD5/AD5/ FLMD1	110	134
HS	Input	Handshake signal for CSIO + HS communication	RESERVE/ HS	PCM0/ $\overline{\text{WAIT}}$	85	105	Not needed	–	–	Not needed	–	–
VDD	–	VDD voltage generation/volt age monitor	VDD	V <sub>DD</sub>	9	11	V <sub>DD</sub>	9	11	V <sub>DD</sub>	9	11
				BV <sub>DD</sub>	104	124, 153	BV <sub>DD</sub>	104	124, 153	BV <sub>DD</sub>	104	124, 153
				EV <sub>DD</sub>	34	39, 69	EV <sub>DD</sub>	34	39, 69	EV <sub>DD</sub>	34	39, 69
				AV <sub>REF0</sub>	1	1	AV <sub>REF0</sub>	1	1	AV <sub>REF0</sub>	1	1
				AV <sub>REF1</sub>	5	5	AV <sub>REF1</sub>	5	5	AV <sub>REF1</sub>	5	5
GND	–	Ground	GND	V <sub>SS</sub>	11	13	V <sub>SS</sub>	11	13	V <sub>SS</sub>	11	13
				AV <sub>SS</sub>	2	2	AV <sub>SS</sub>	2	2	AV <sub>SS</sub>	2	2
				BV <sub>SS</sub>	103	123, 154	BV <sub>SS</sub>	103	123, 154	BV <sub>SS</sub>	103	123, 154
				EV <sub>SS</sub>	33	38, 70	EV <sub>SS</sub>	33	38, 70	EV <sub>SS</sub>	33	38, 70

- Cautions**
- Be sure to connect the REGC pin to GND via 4.7  $\mu\text{F}$  capacitor.
  - Clock cannot be supplied from the CLK pin of the flash memory programmer.  
Create an oscillator on the board and supply clock.

**Remark**

SJ3-H: V850E/SJ3-H  
SK3-H: V850E/SK3-H  
GJ (V850E/SJ3-H): 144-pin plastic LQFP (fine pitch) (20 × 20)  
GM (V850E/SK3-H): 176-pin plastic LQFP (fine pitch) (24 × 24)

**Table 32-6. Wiring of V850E/SJ3-H, V850E/SK3-H Flash Writing Adapters  
(FA-144GJ-GAE-B, FA-176GM-GAR-B) (2/2)**

&lt;R&gt;

Flash Memory Programmer (PG-FP5) Connection Pin			Name of FA Board Pin	CSIB0 + HS Used			CSIB3 Used		
Signal Name	I/O	Pin Function		Pin Name	Pin No.		Pin Name	Pin No.	
					SJ3-H	SK3-H		SJ3-H	SK3-H
					GJ	GM		GJ	GM
SI/RxD	Input	Receive signal	SI	P911/A11/SOB3	72	88	P911/A11/SOB3	72	88
SO/TxD	Output	Transmit signal	SO	P910/A10/SIB3	71	87	P910/A10/SIB3	71	87
SCK	Output	Transfer clock	SCK	P912/A12/ $\overline{\text{SCKB3}}$	73	89	P912/A12/ $\overline{\text{SCKB3}}$	73	89
CLK	Output	Clock to V850E/SJ3-H, V850E/SK3-H	X1	Not needed	–	–	Not needed	–	–
			X2	Not needed	–	–	Not needed	–	–
/RESET	Output	Reset signal	/RESET	$\overline{\text{RESET}}$	14	16	$\overline{\text{RESET}}$	14	16
FLMD0	Output	Write voltage	FLMD0	FLMD0	8	10	FLMD0	8	10
FLMD1	Output	Write voltage	FLMD1	PLD5/AD5/FLMD1	110	134	PLD5/AD5/FLMD1	110	134
HS	Input	Handshake signal for CSIO + HS communication	RESERVE/HS	PCM0/ $\overline{\text{WAIT}}$	85	105	Not needed	–	–
VDD	–	VDD voltage generation/voltage monitor	VDD	V <sub>DD</sub>	9	11	V <sub>DD</sub>	9	9
				BV <sub>DD</sub>	104	124, 153	BV <sub>DD</sub>	104	124, 153
				EV <sub>DD</sub>	34	39, 69	EV <sub>DD</sub>	34	39, 69
				AV <sub>REF0</sub>	1	1	AV <sub>REF0</sub>	1	1
				AV <sub>REF1</sub>	5	5	AV <sub>REF1</sub>	5	5
GND	–	Ground	GND	V <sub>SS</sub>	11	13	V <sub>SS</sub>	11	13
				AV <sub>SS</sub>	2	2	AV <sub>SS</sub>	2	2
				BV <sub>SS</sub>	103	123, 154	BV <sub>SS</sub>	103	123, 154
				EV <sub>SS</sub>	33	38, 70	EV <sub>SS</sub>	33	38, 70

- Cautions**
1. Be sure to connect the REGC pin to GND via 4.7  $\mu\text{F}$  capacitor.
  2. Clock cannot be supplied from the CLK pin of the flash memory programmer.  
Create an oscillator on the board and supply clock.

**Remark**

SJ3-H: V850E/SJ3-H  
SK3-H: V850E/SK3-H  
GJ (V850E/SJ3-H): 144-pin plastic LQFP (fine pitch) (20 × 20)  
GM (V850E/SK3-H): 176-pin plastic LQFP (fine pitch) (24 × 24)

Figure 32-6. Example of Wiring of V850E/SJ3-H Flash Writing Adapter (FA-144GJ-GAE-B)  
(in CSIB0 + HS Mode) (1/2)

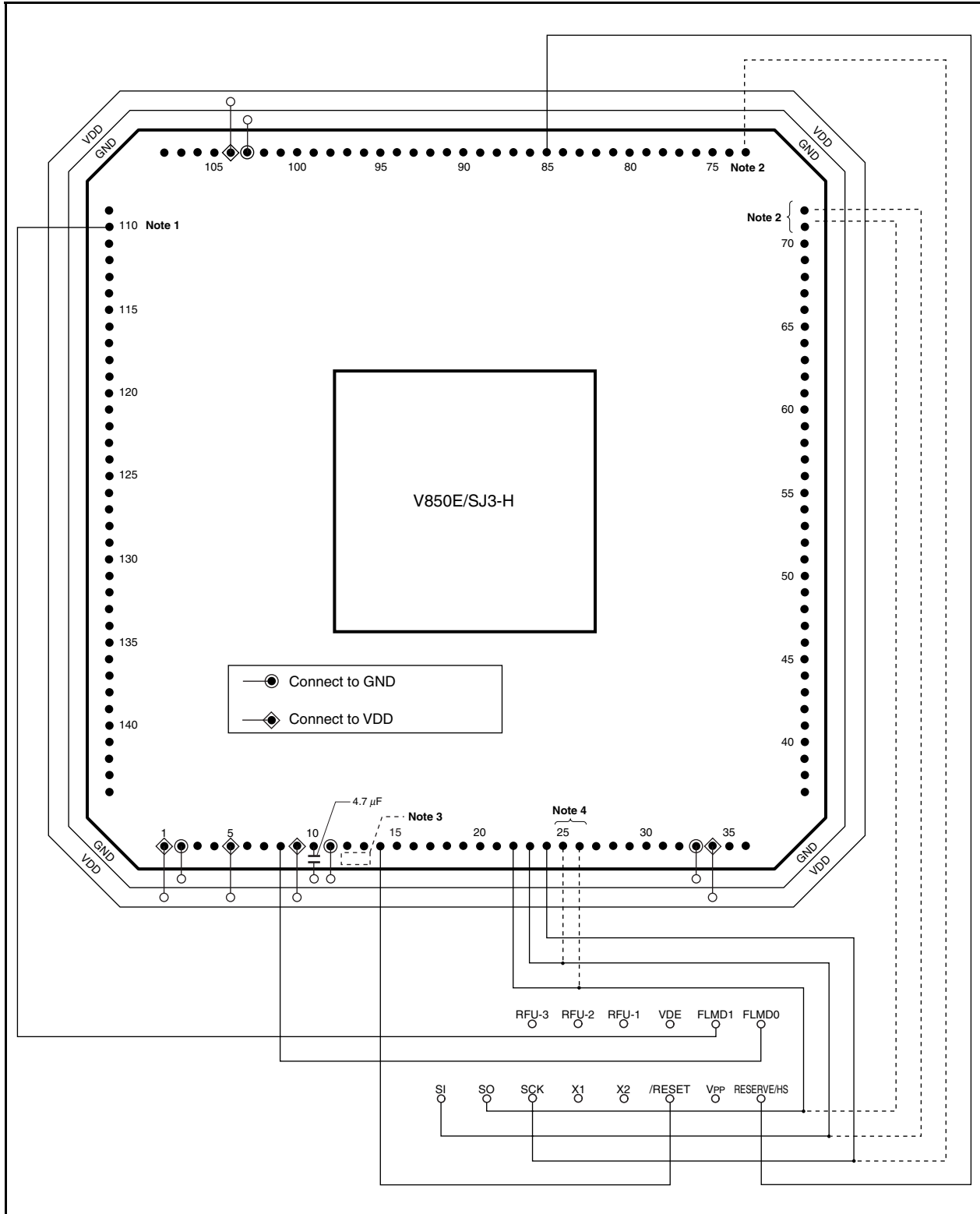

**Figure 32-6. Example of Wiring of V850E/SJ3-H Flash Writing Adapter (FA-144GJ-GAE-B)  
(in CSIB0 + HS Mode) (2/2)**

- Notes**
1. Wire the FLMD1 pin as shown below, or connect it to GND on board via a pull-down resistor.
  2. Pins used when CSIB3 is used
  3. Supply a clock by creating an oscillator on the flash writing adapter (enclosed by the broken lines). Here is an example of the oscillator.

**Example**

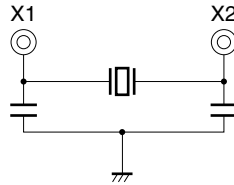

4. Pins used when UARTA0 is used.

**Caution** Do not input a high level to the  $\overline{\text{DRST}}$  pin.

- Remarks**
1. Process the pins not shown in accordance with processing of unused pins (see 2.4 Pin I/O Circuit Types, I/O Buffer Power Supplies and Handling of Unused Pins).
  2. This adapter is for the 144-pin plastic LQFP package.

Figure 32-7. Example of Wiring of V850E/SK3-H Flash Writing Adapter (FA-176GM-GAR-B)  
(in CSIB0 + HS Mode) (1/2)

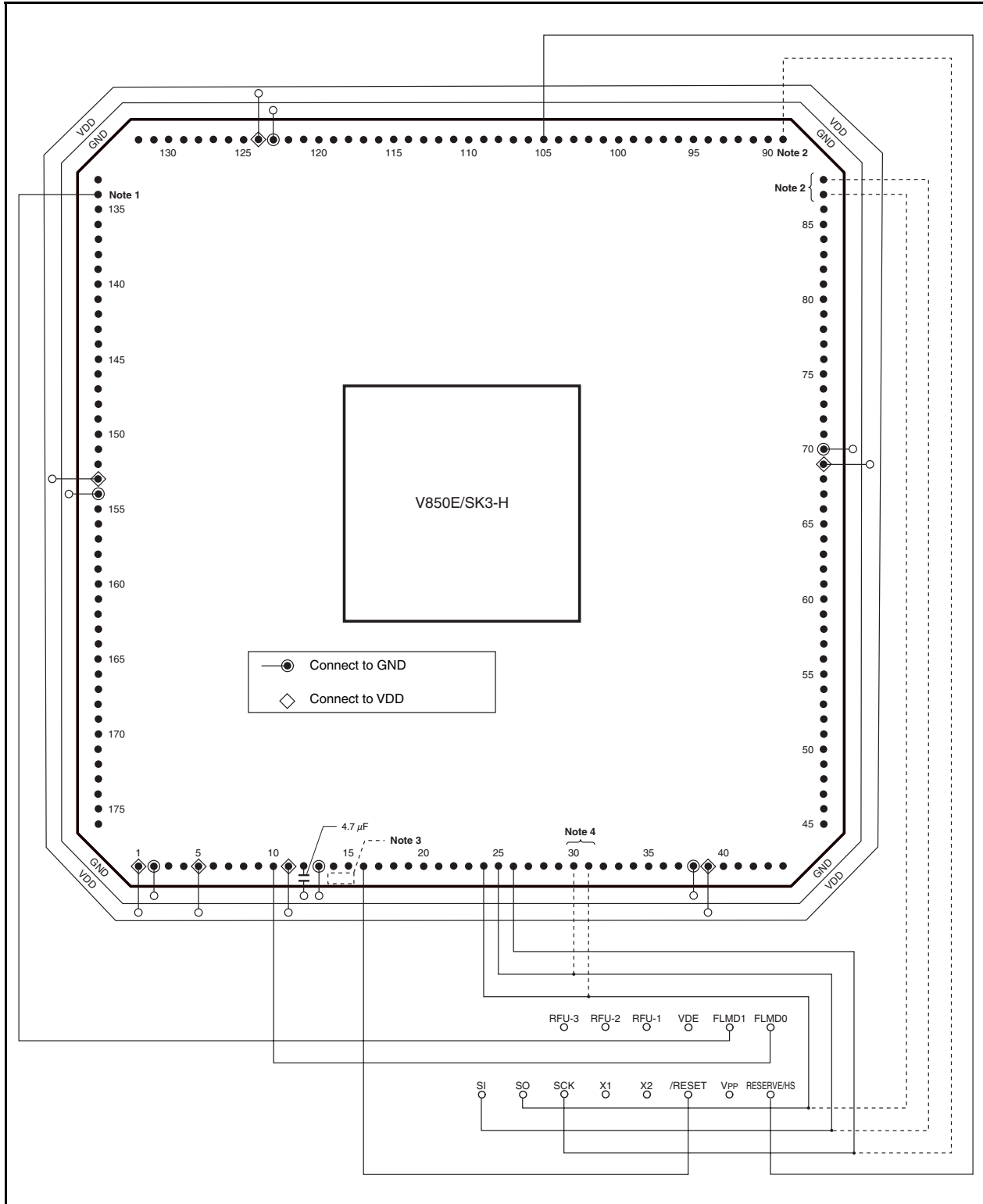

**Figure 32-7. Example of Wiring of V850E/SK3-H Flash Writing Adapter (FA-176GM-GAR-B)  
(in CSIB0 + HS Mode) (2/2)**

- Notes**
1. Wire the FLMD1 pin as shown below, or connect it to GND on board via a pull-down resistor.
  2. Pins used when CSIB3 is used
  3. Supply a clock by creating an oscillator on the flash writing adapter (enclosed by the broken lines). Here is an example of the oscillator.

**Example**

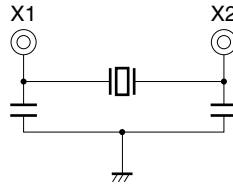

4. Pins used when UARTA0 is used.

**Caution** Do not input a high level to the  $\overline{\text{DRST}}$  pin.

- Remarks**
1. Process the pins not shown in accordance with processing of unused pins (see 2.4 Pin I/O Circuit Types, I/O Buffer Power Supplies and Handling of Unused Pins).
  2. This adapter is for the 176-pin plastic LQFP package.

### 32.4.3 Flash memory control

The following shows the procedure for manipulating the flash memory.

**Figure 32-8. Procedure for Manipulating Flash Memory**

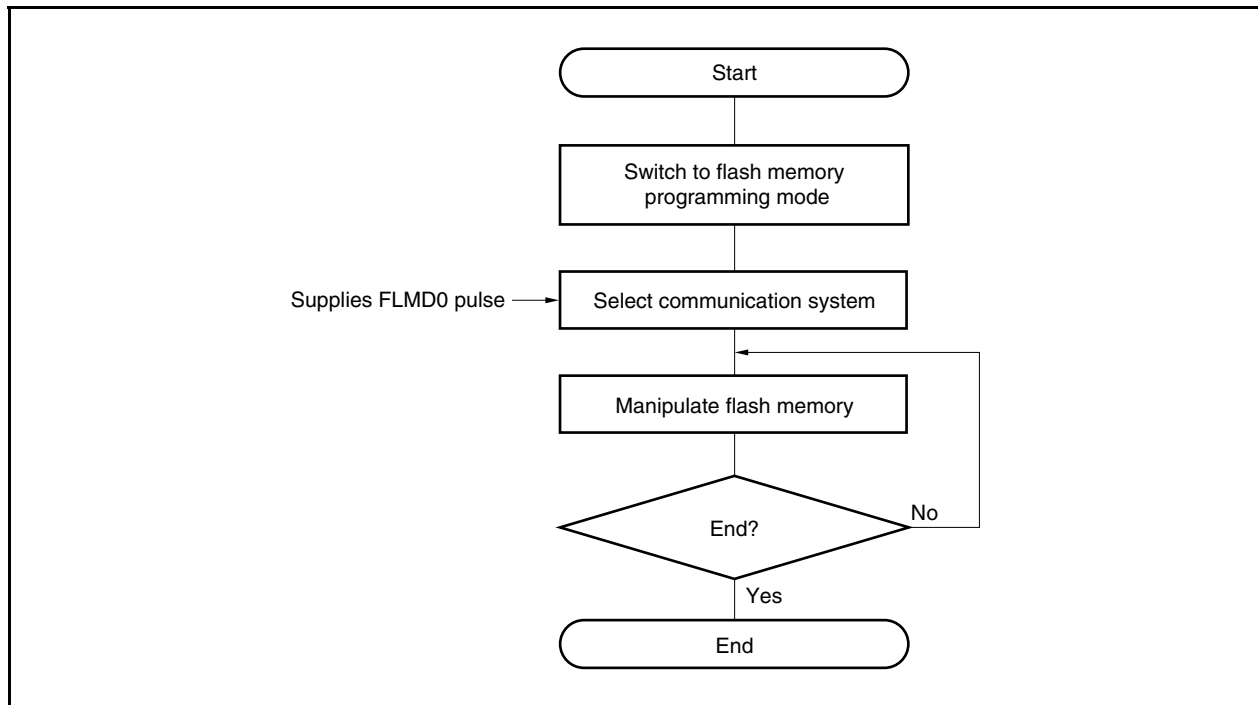



### 32.4.4 Selection of communication mode

In the V850E/SJ3-H and V850E/SK3-H, the communication mode is selected by inputting pulses (12 pulses max.) to the FLMD0 pin after switching to the flash memory programming mode. The FLMD0 pulse is generated by the dedicated flash memory programmer.

The following shows the relationship between the number of pulses and the communication mode.

Figure 32-9. Selection of Communication Mode

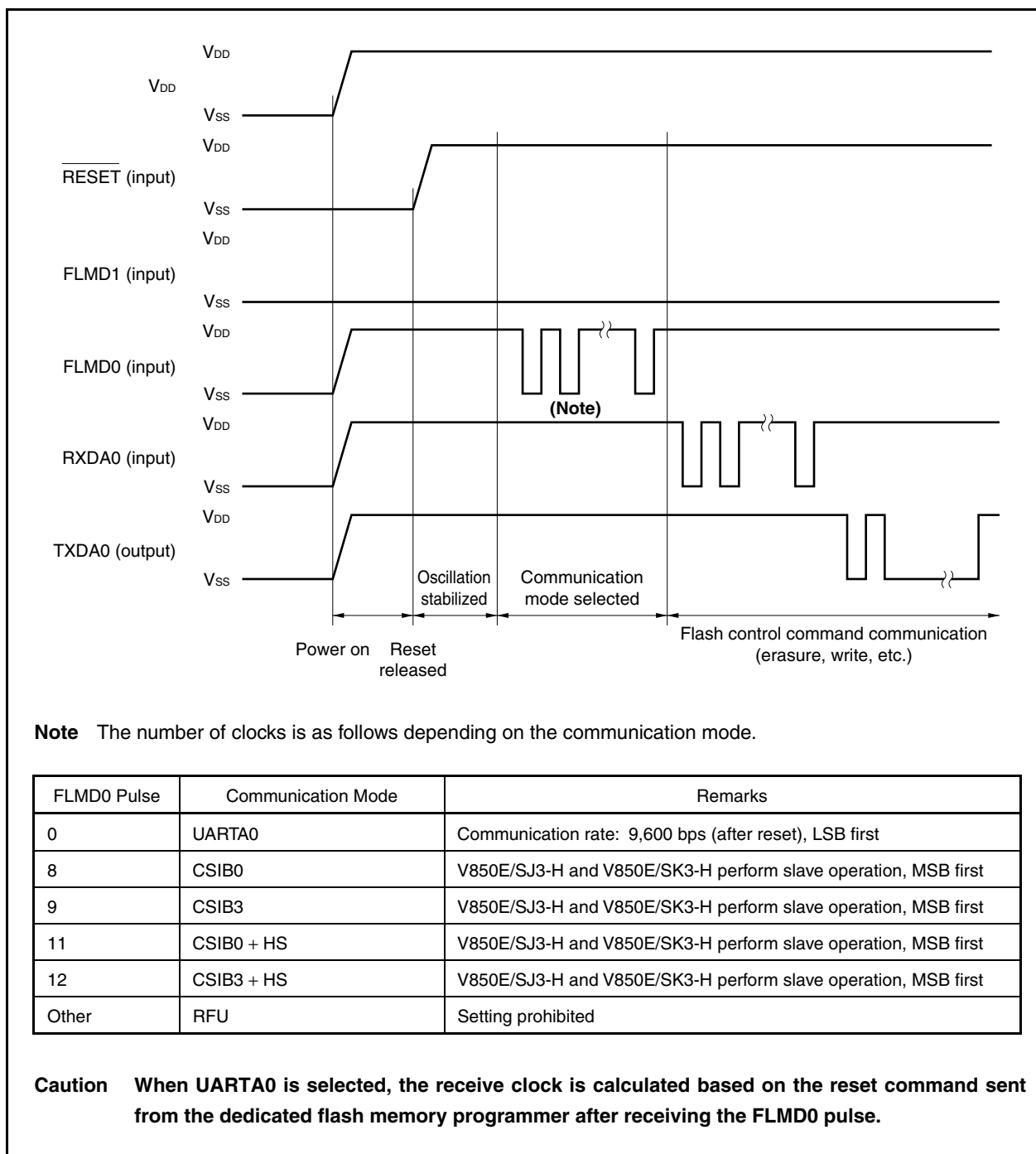

### 32.4.5 Communication commands

The V850E/SJ3-H and V850E/SK3-H communicate with the dedicated flash memory programmer by means of commands. The signals sent from the dedicated flash memory programmer to the V850E/SJ3-H and V850E/SK3-H are called “commands”. The response signals sent from the V850E/SJ3-H and V850E/SK3-H to the dedicated flash memory programmer are called “response commands”.

**Figure 32-10. Communication Commands**

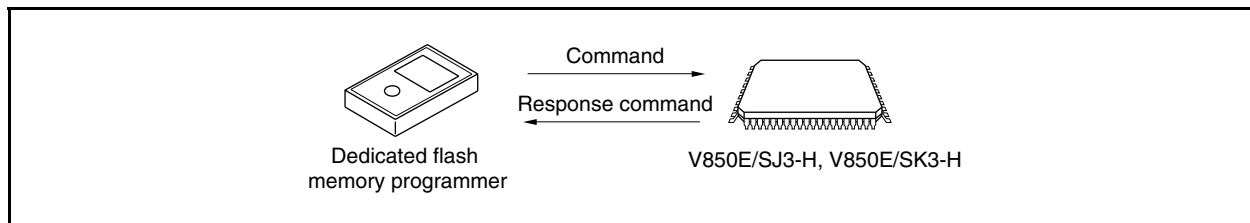

The following shows the commands for flash memory control in the V850E/SJ3-H and V850E/SK3-H. All of these commands are issued from the dedicated flash memory programmer, and the V850E/SJ3-H and V850E/SK3-H perform the processing corresponding to the commands.

**Table 32-7. Flash Memory Control Commands**

Classification	Command Name	Support			Function
		CSIB0, CSIB3	CSIB0 + HS, CSIB3 + HS	UARTA0	
Blank check	Block blank check command	√	√	√	Checks if the contents of the memory in the specified block have been correctly erased.
Erase	Chip erase command	√	√	√	Erases the contents of the entire memory.
	Block erase command	√	√	√	Erases the contents of the memory of the specified block.
Program	Program command	√	√	√	Writes the specified address range, and executes a contents verify check.
Verify	Verify command	√	√	√	Compares the contents of memory in the specified address range with data transferred from the flash memory programmer.
	Checksum command	√	√	√	Reads the checksum in the specified address range.
Read	Read command	√	√	√	Reads the data written to the flash memory.
System setting, control	Silicon signature command	√	√	√	Reads silicon signature information.
	Security setting command	√	√	√	Disables the chip erase command, block erase command, program command, read command, and boot block cluster rewrite.

### 32.4.6 Pin connection

When performing on-board writing, mount a connector on the target system to connect to the dedicated flash memory programmer. Also, incorporate a function on-board to switch from the normal operation mode to the flash memory programming mode.

In the flash memory programming mode, all the pins not used for flash memory programming become the same status as that immediately after reset. Therefore, pin handling is required when the external device does not acknowledge the status immediately after a reset.

#### (1) FLMD0 pin

In the normal operation mode, input a voltage of  $V_{SS}$  level to the FLMD0 pin. In the flash memory programming mode, supply a write voltage of  $V_{DD}$  level to the FLMD0 pin.

Because the FLMD0 pin serves as a write protection pin in the self programming mode, a voltage of  $V_{DD}$  level must be supplied to the FLMD0 pin via port control, etc., before writing to the flash memory. For details, see **32.5.5 (1) FLMD0 pin**.

**Figure 32-11. FLMD0 Pin Connection Example**

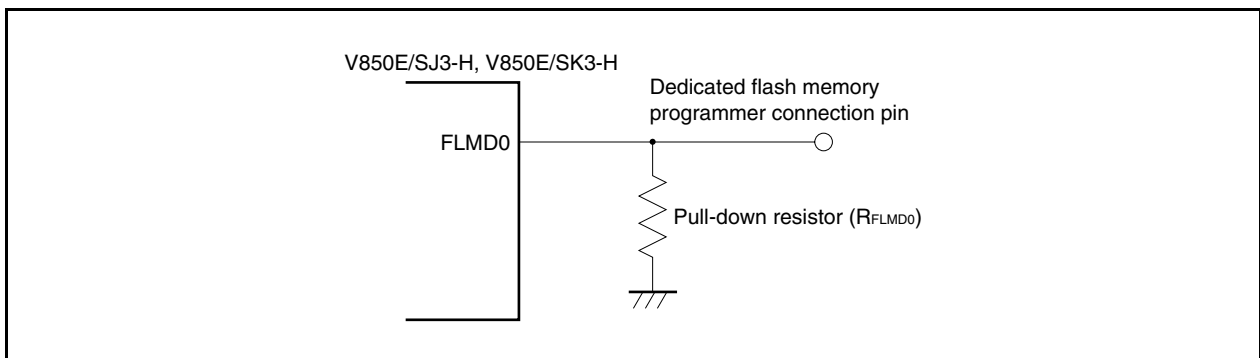

**(2) FLMD1 pin**

When 0 V is input to the FLMD0 pin, the FLMD1 pin does not function. When  $V_{DD}$  is supplied to the FLMD0 pin, the flash memory programming mode is entered, so 0 V must be input to the FLMD1 pin. The following shows an example of the connection of the FLMD1 pin.

**Figure 32-12. FLMD1 Pin Connection Example**

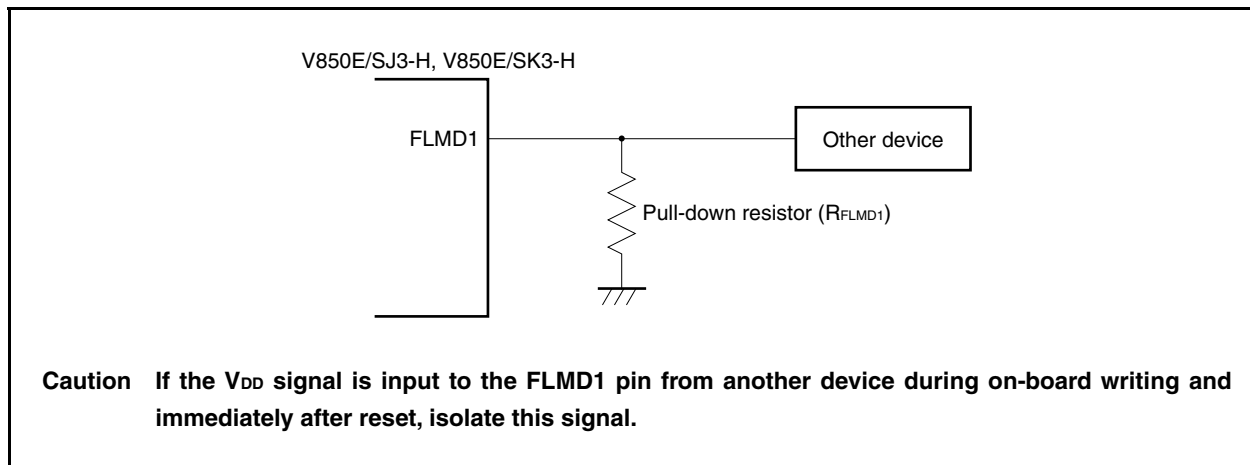

**Table 32-8. Relationship Between FLMD0 and FLMD1 Pins and Operation Mode When Reset Is Released**

FLMD0	FLMD1	Operation Mode
0	Don't care	Normal operation mode
$V_{DD}$	0	Flash memory programming mode
$V_{DD}$	$V_{DD}$	Setting prohibited

**(3) Serial interface pin**

The following shows the pins used by each serial interface.

**Table 32-9. Pins Used by Serial Interfaces**

Serial Interface	Pins Used
UARTA0	TXDA0, RXDA0
CSIB0	SOB0, SIB0, $\overline{\text{SCKB0}}$
CSIB3	SOB3, SIB3, $\overline{\text{SCKB3}}$
CSIB0 + HS	SOB0, SIB0, $\overline{\text{SCKB0}}$ , PCM0
CSIB3 + HS	SOB3, SIB3, $\overline{\text{SCKB3}}$ , PCM0

When connecting a dedicated flash memory programmer to a serial interface pin that is connected to another device on-board, care should be taken to avoid conflict of signals and malfunction of the other device.

**(a) Conflict of signals**

When the dedicated flash memory programmer (output) is connected to a serial interface pin (input) that is connected to another device (output), a conflict of signals occurs. To avoid the conflict of signals, isolate the connection to the other device or set the other device to the output high-impedance status.

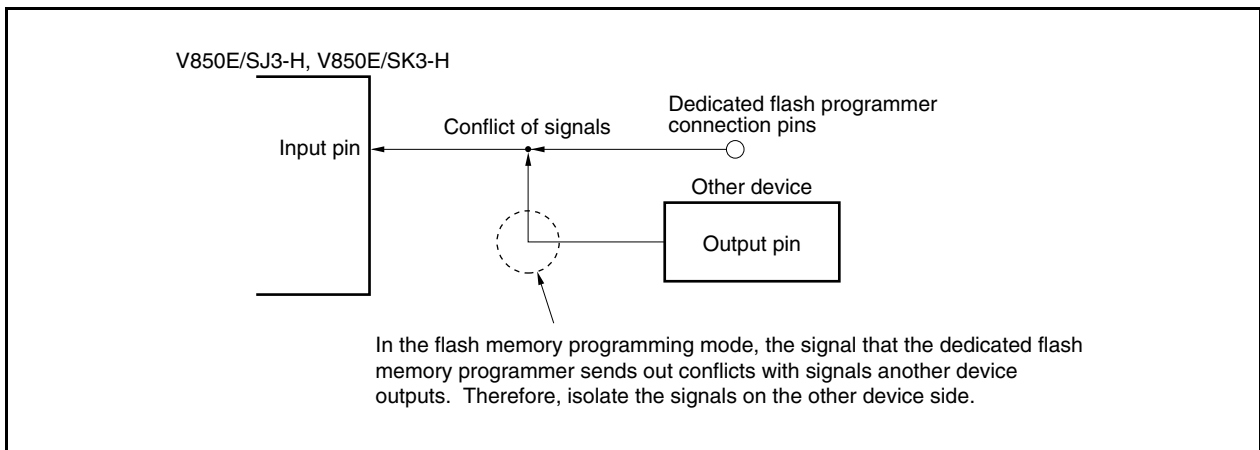
**Figure 32-13. Conflict of Signals (Serial Interface Input Pin)**

**(b) Malfunction of other device**

When the dedicated flash memory programmer (output or input) is connected to a serial interface pin (input or output) that is connected to another device (input), the signal is output to the other device, causing the device to malfunction. To avoid this, isolate the connection to the other device.

**Figure 32-14. Malfunction of Other Device**

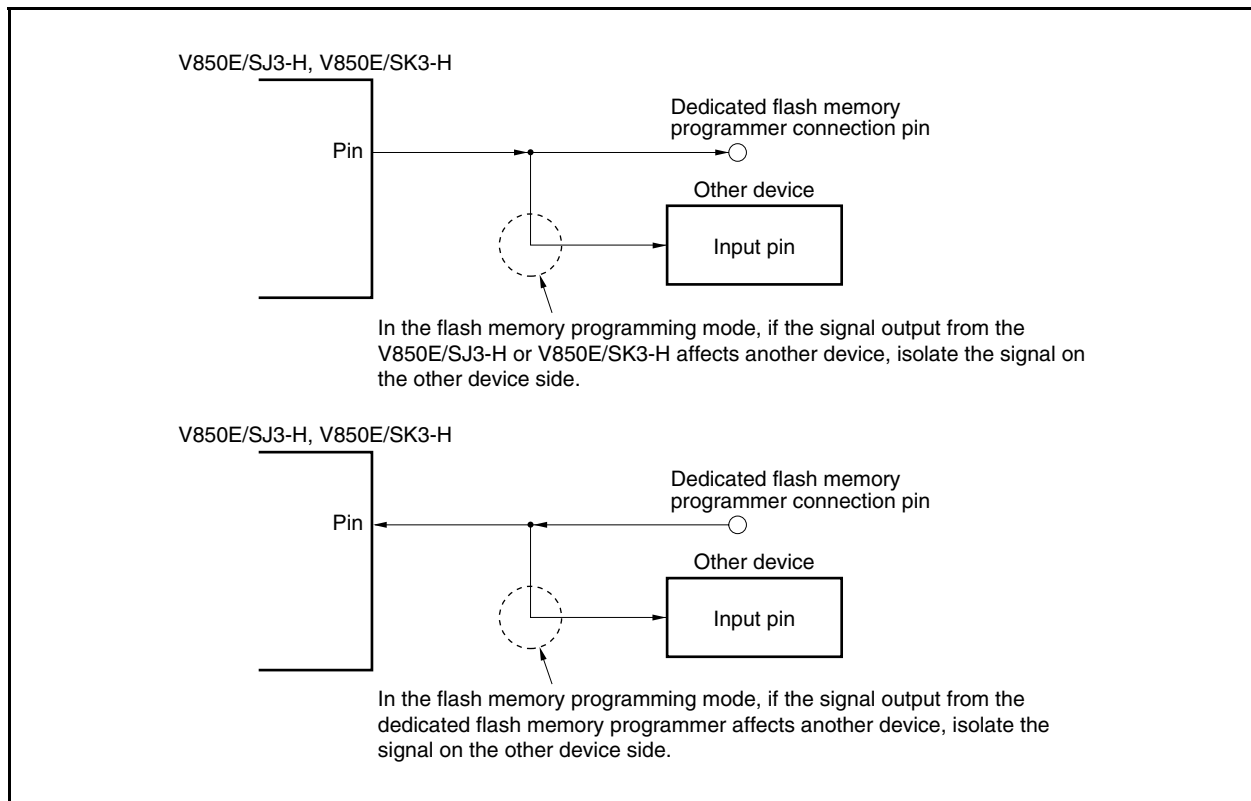

**(4) RESET pin**

When the reset signals of the dedicated flash memory programmer are connected to the  $\overline{\text{RESET}}$  pin that is connected to the reset signal generator on-board, a conflict of signals occurs. To avoid the conflict of signals, isolate the connection to the reset signal generator.

When a reset signal is input from the user system in the flash memory programming mode, the programming operation will not be performed correctly. Therefore, do not input signals other than the reset signals from the dedicated flash memory programmer.

**Figure 32-15. Conflict of Signals ( $\overline{\text{RESET}}$  Pin)**

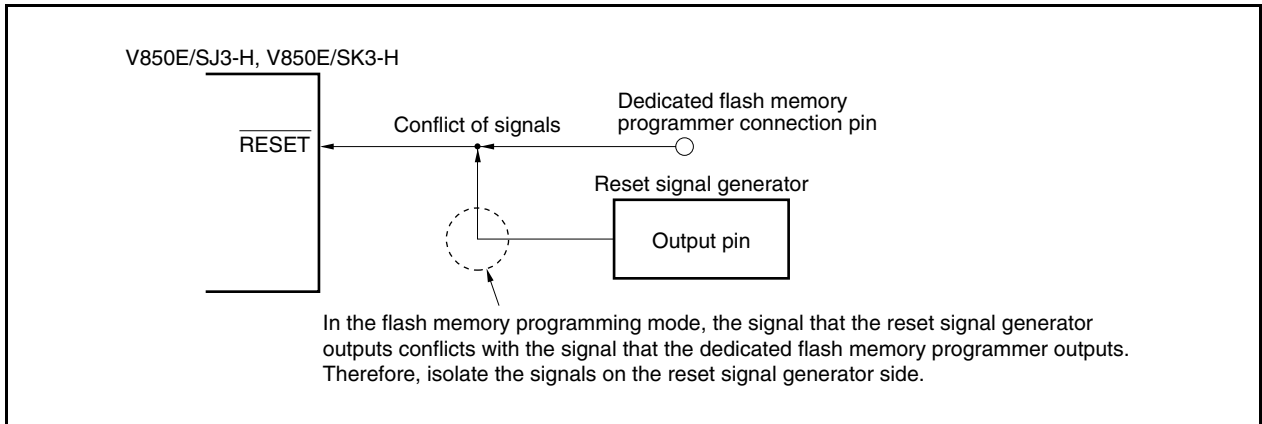
**(5) Port pins (including NMI)**

When the system shifts to the flash memory programming mode, all the pins that are not used for flash memory programming are in the same status as that immediately after reset. If the external device connected to each port does not recognize the status of the port immediately after reset, pins require appropriate processing, such as connecting to  $V_{DD}$  via a resistor or connecting to  $V_{SS}$  via a resistor.

**(6) Other signal pins**

Connect X1, X2, XT1, XT2, and REGC in the same status as that in the normal operation mode.

During flash memory programming, input a low level to the  $\overline{\text{DRST}}$  pin or leave it open. Do not input a high level.

**(7) Power supply**

Supply the same power ( $V_{DD}$ ,  $V_{SS}$ ,  $EV_{DD}$ ,  $EV_{SS}$ ,  $BV_{DD}$ ,  $BV_{SS}$ ,  $AV_{REF0}$ ,  $AV_{REF1}$ ,  $AV_{SS}$ ) as in normal operation mode.

## 32.5 Rewriting by Self Programming

### 32.5.1 Overview

The V850E/SJ3-H and V850E/SK3-H support a flash macro service that allows the user program to rewrite the internal flash memory by itself. By using this interface and a self programming library that is used to rewrite the flash memory with a user application program, the flash memory can be rewritten by a user application transferred in advance to the internal RAM, external memory or expanded internal RAM. Consequently, the user program can be upgraded and constant data<sup>Note</sup> can be rewritten in the field.

**Note** Make sure that constant data of rewriting target is situated in a different block than program code. See **32.2 Memory Configuration** for the block configuration.

**Figure 32-16. Concept of Self Programming**

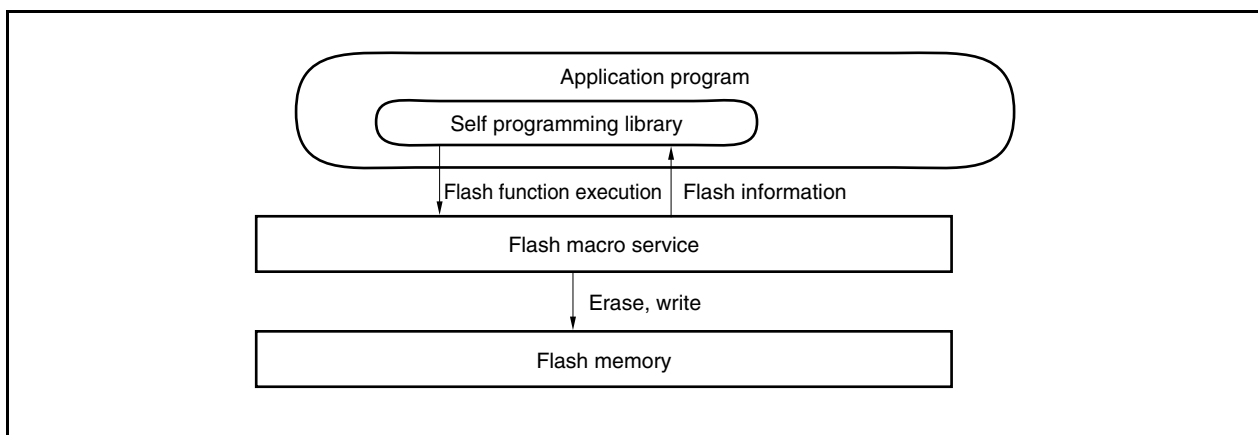



### 32.5.2 Features

#### (1) Function of self programming library

Flash memory self programming by the user program can be performed by using a self programming library. This library has a set for calling C functions that execute the following features.

- Blank check, erase, write, and verify of flash memory
- Setting boot block cluster and boot swap
- Security information setting
- Obtaining information on flash memory

#### (2) Secure self programming (boot swap function)

The V850E/SJ3-H and V850E/SK3-H support a function to swap the blocks (clusters) of a flash memory block that starts from address 00000000H with a different cluster of the same size which is located at the addresses higher than those of the cluster.

Boot swap cluster is a block that is swapped during boot swapping.

The boot swap cluster is a boot area of the application program and an area can be selected. Security setting to prohibit rewriting of the boot block cluster can be made.

The size of the boot block cluster can be selected from 16, 32, 64, and 128 KB, depending on the setting of the boot block cluster. The boot swap function can be executed in that area. For details, refer to **Table 32-10 Relationship Between Boot Block Cluster and Boot Swap Cluster**.

In addition, which of the two clusters is active (to be booted) can be controlled by using a boot flag. The boot flag is stored in an area for flash information.

The relationship between setting of an area of the boot block cluster and the boot swap cluster that is determined by it is shown below.

**Table 32-10. Relationship Between Boot Block Cluster and Boot Swap Cluster**

Boot Block Cluster Set Value <sup>Note</sup>	Boot Block Cluster	Boot Swap Cluster
00H	00000000H to 00000FFFH (4 KB)	00000000H to 00003FFFH (16 KB)
:	:	
03H	00000000H to 00003FFFH (16 KB)	
04H	00000000H to 00004FFFH (20 KB)	00000000H to 00007FFFH (32 KB)
:	:	
07H	00000000H to 00007FFFH (32 KB)	
08H	00000000H to 00008FFFH (36 KB)	00000000H to 0000FFFFH (64 KB)
:	:	
0FH	00000000H to 0000FFFFH (64 KB)	
10H	00000000H to 00010FFFH (68 KB)	00000000H to 0001FFFFH (128 KB)
:	:	
1FH	00000000H to 0001FFFFH (128 KB)	
20H	00000000H to 00020FFFH (132 KB)	
:	:	
7FH	00000000H to 0007FFFFH (512 KB)	
80H	Setting prohibited	
:		
FFH		

**Note** Settable by GUI of the flash programmer or by flash self programming

Figure 32-17 shows an example of the boot swap function of a cluster consisting of flash memory blocks (set value of boot block cluster = 04H (boot swap cluster: 32 KB, boot block cluster: 20 KB)). After boot\_flag is reversed, not (boot\_flag) is assumed, and blocks 8 to 15 become active boot clusters. Therefore, the user program is started by a new boot swap cluster after the next time reset is released.

**Figure 32-17. Example of Boot Swap Function (Set Value of Boot Block Cluster = 04H  
(Boot Swap Cluster: 32 KB, Boot Block Cluster: 20 KB))**

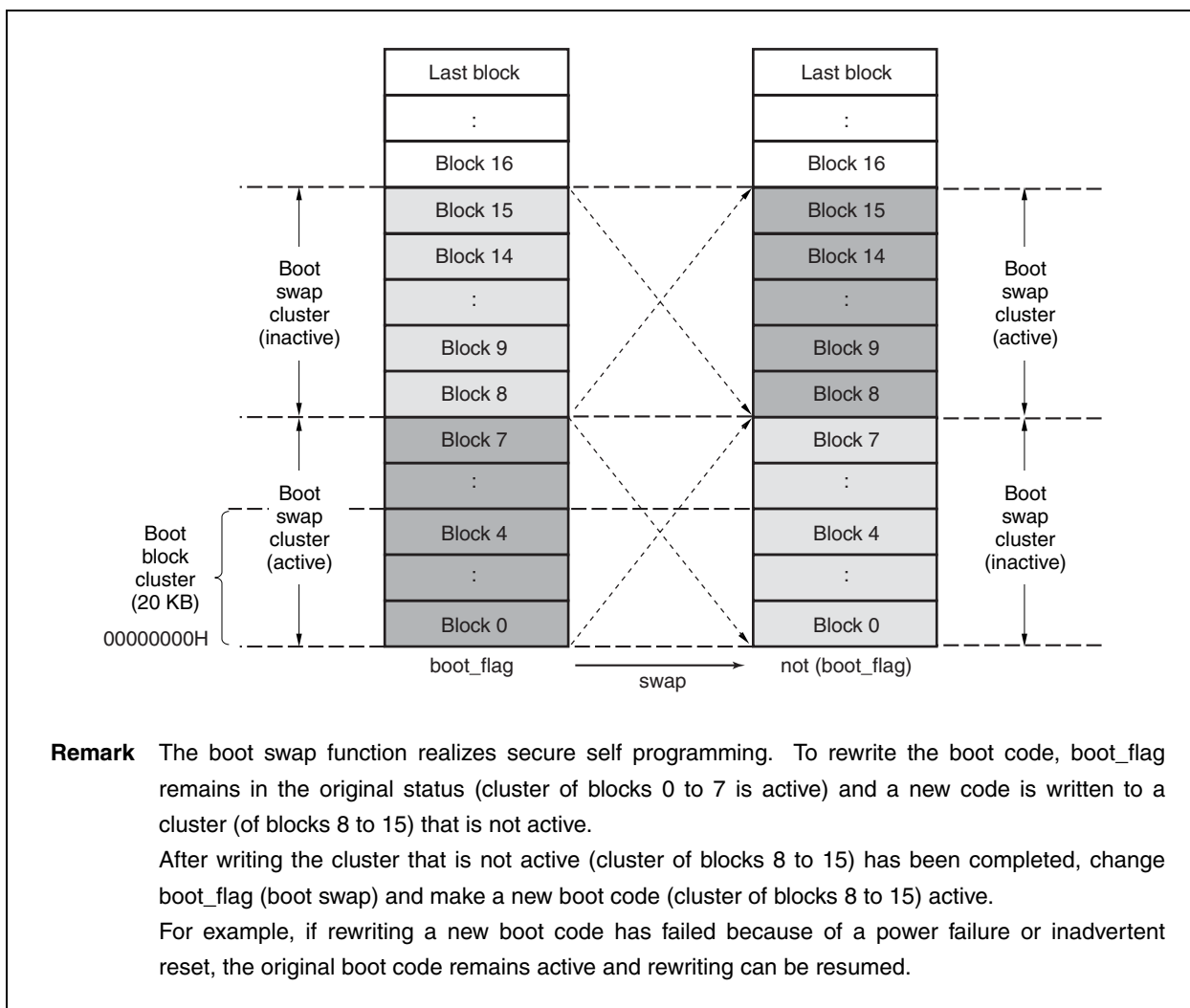

**Remark** The boot swap function realizes secure self programming. To rewrite the boot code, `boot_flag` remains in the original status (cluster of blocks 0 to 7 is active) and a new code is written to a cluster (of blocks 8 to 15) that is not active.

After writing the cluster that is not active (cluster of blocks 8 to 15) has been completed, change `boot_flag` (boot swap) and make a new boot code (cluster of blocks 8 to 15) active.

For example, if rewriting a new boot code has failed because of a power failure or inadvertent reset, the original boot code remains active and rewriting can be resumed.

### (3) Interrupt support

Instructions cannot be fetched from the flash memory during self programming. Conventionally, a user handler written to the flash memory could not be used even if an interrupt occurred.

Therefore, in the V850E/SJ3-H and V850E/SK3-H, to use an interrupt during self programming, processing transits to the specific address<sup>Note</sup> in the internal RAM. Allocate the jump instruction that transits processing to the user interrupt servicing at the specific address<sup>Note</sup> in the internal RAM.

**Note** NMI interrupt: Start address of internal RAM  
Maskable interrupt: Start address of internal RAM + 4 addresses

32.5.3 Standard self programming flow

The entire processing to rewrite the flash memory by flash self programming is illustrated below.

Figure 32-18. Standard Self Programming Flow

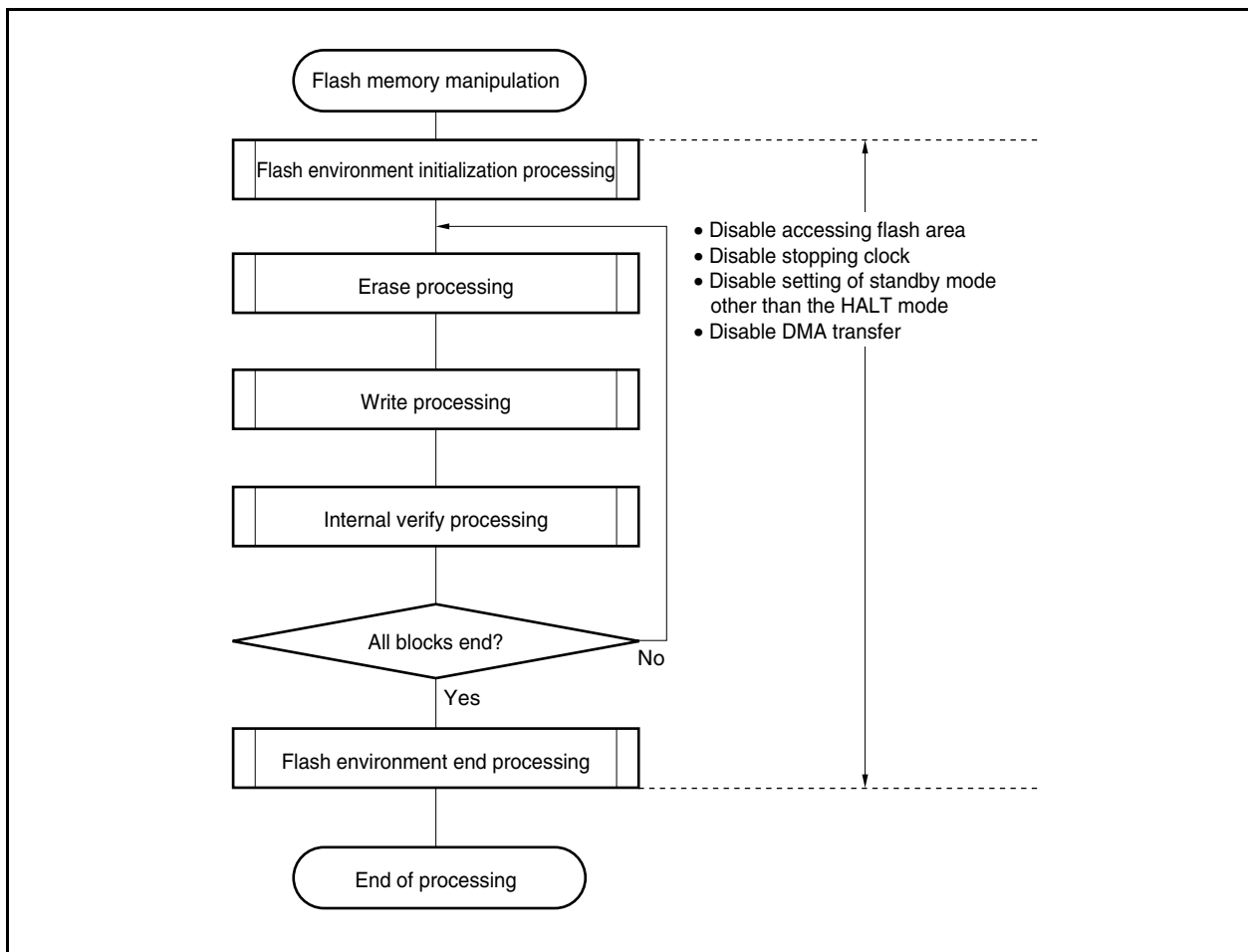

## 32.5.4 Flash functions

Table 32-11. Flash Function List

Function Name	Outline	Support
FlashInit	Self-programming library initialization	√
FlashEnv	Flash environment start/end	√
FlashFLMDCheck	FLMD pin check	√
FlashStatusCheck	Hardware processing execution status check	√
FlashBlockErase	Block erase	√
FlashWordWrite	Data write	√
FlashBlockVerify	Internal verification of block	√
FlashBlockBlankCheck	Blank check of block	√
FlashSetInfo	Flash information setting	√
FlashGetInfo	Flash information acquisition	√
FlashBootSwap	Boot swap execution	√

## 32.5.5 Pin processing

## (1) FLMD0 pin

The FLMD0 pin is used to set the operation mode when reset is released and to protect the flash memory from being written during self rewriting. It is therefore necessary to keep the voltage applied to the FLMD0 pin at 0 V when reset is released and a normal operation is executed. It is also necessary to apply a voltage of  $V_{DD}$  level to the FLMD0 pin during the self programming mode period via port control before the memory is rewritten.

When self programming has been completed, the voltage on the FLMD0 pin must be returned to 0 V.

Figure 32-19. Mode Change Timing

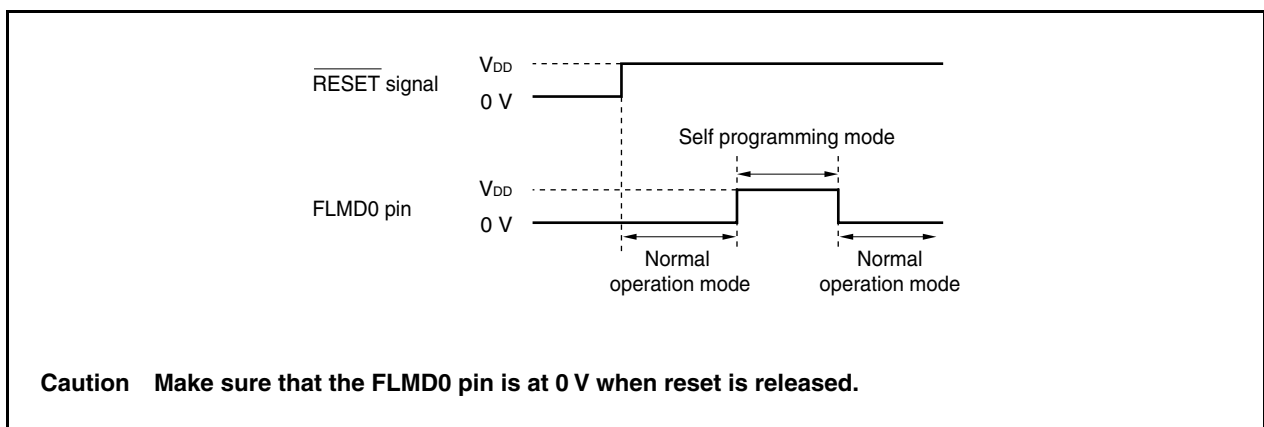

**32.5.6 Internal resources used**

The following table lists the internal resources used for self programming. These internal resources can also be used freely for purposes other than self programming.

**Table 32-12. Internal Resources Used**

Resource Name	Description
Stack area <sup>Note</sup>	An extension of the stack used by the user is used by the library (can be used in both the internal RAM and external RAM).
Library code <sup>Note</sup>	Program entity of library (can be used anywhere other than the flash memory block to be manipulated).
Application program	Executed as a user application. Calls flash functions.
Maskable interrupt	Can be used in user application execution status or self programming status. To use this interrupt in the self-programming status, since the processing transits to the address of the internal RAM start address + 4 addresses, allocate the jump instruction that transits the processing to the user interrupt servicing at the address of the internal RAM start address + 4 addresses in advance.
NMI interrupt	Can be used in user application execution status or self programming status. To use this interrupt in the self-programming status, since the processing transits to the address of the internal RAM start address, allocate the jump instruction that transits the processing to the user interrupt servicing at the internal RAM start address in advance.

**Note** About resources used, refer to the **Flash Memory Self-Programming Library User's Manual**.

## CHAPTER 33 OPTION BYTE FUNCTION

The flash memory of the V850E/SJ3-H and V850E/SK3-H includes an option byte area for setting the option byte function. When writing a program to the flash memory, be sure to set the option byte area corresponding to the following options.

The option byte functions determined by the option bytes are as follows.

- Selection of DMA transfer start factor table set by the DTFR register
- Selection of whether to enable or disable use of the INTIIC0 and INTIIC2 signals as DMA transfer start factors in DTFR register setting
- Specification of watchdog timer 2 input clock
- Specification of watchdog timer 2 operating mode
- Selection of whether the on-chip oscillator can be stopped by software or not
- Selection of clock mode
- Selection of PLL input clock ( $f_{PLL}$ ) division ratio

<R>

The option bytes are stored as 16-bit data in flash memory addresses 0000007AH and 0000007BH.

## 33.1 Option Byte (0000007AH)

Address: 0000007AH

7	6	5	4	3	2	1	0
0	0	DTFROB0	DTFROB1	0	0	WDTMD1	RMOPI0

DTFROB1	Selection of whether to enable or disable use of INTIIC0 and INTIIC2 as DMA transfer start factors in DTFR register setting
0	DMA transfer start factor when DTFR.IFCn5 to DTFR.IFCn0 bits = 28H: INTUA1R/INTIIC2 (shared) DMA transfer start factor when DTFR.IFCn5 to DTFR.IFCn0 bits = 2AH: INTUA2R/INTIIC0 (shared)
1	DMA transfer start factor when DTFR.IFCn5 to DTFR.IFCn0 bits = 28H: INTUA1R (INTIIC2 is not a DMA transfer start factor) DMA transfer start factor when DTFR.IFCn5 to DTFR.IFCn0 bits = 2AH: INTUA2R (INTIIC0 is not a DMA transfer start factor)

WDTMD1	Setting of watchdog timer 2 mode
0	Input clock and operating mode can be selected by WDTM2 register. Input clock: Selectable from peripheral clock ( $f_{XP}$ ), on-chip oscillation clock ( $f_R$ ), or subclock ( $f_{XT}$ ) Operating mode: Selectable from non-maskable interrupt request mode (INTWDT2 signal generated) or reset mode (WDT2RES signal generated)
1	Input clock and operating mode cannot be selected by WDTM2 register. Input clock: Fixed to internal oscillation clock ( $f_R$ ) Operating mode: Fixed to reset mode (WDT2RES signal generated)

RMOPI0	Internal oscillator can/cannot be stopped by software
0	Can be stopped
1	Cannot be stopped

**Cautions 1. See Table 22-1 DMA Transfer Start Factors for details of the DTFROB0 bit.**

**2. Be sure to set bits 2, 3, 6 and 7 to "0".**



## 33.2 Option Byte (000007BH)

Address: 000007BH

	7	6	5	4	3	2	1	0
<R>	0	0	0	0	SELCM2	SELCM1	SELCM0	PLLIO

SELCM2	SELCM1	SELCM0	Clock mode selection
0	0	0	Clock mode 1
1	1	1	Clock mode 2
1	0	0	Clock mode 3
1	1	0	Clock mode 4
Other than above			Setting prohibited

PLLIO	PLL input clock ( $f_{PLL}$ ) selection
0	$f_{PLL} = f_x$ (no division)
1	$f_{PLL} = f_x/2$ (division by 2)

- <R>
- Cautions**
1. Be sure to set the PLLIO bit to “0” (no division) in clock mode 4.
  2. Be sure to set bits 4 to 7 to “0”.

An example of the program when using the CA850 is shown below.

[Program example]

```
#-----  
# OPTION_BYTES  
#-----  
.section "OPTION_BYTES"  
.byte 0b00000001 -- 0x7a  
.byte 0b00000000 -- 0x7b  
.byte 0b00000000 -- 0x7c  
.byte 0b00000000 -- 0x7d  
.byte 0b00000000 -- 0x7e  
.byte 0b00000000 -- 0x7f
```

**Caution** Be sure to write 6 bytes of data to this section. If fewer than 6 bytes are written, an error will occur at linking.

**Error message:** F4112: illegal "OPTION\_BYTES" section size.

**Remark** Set addresses 007CH to 007FH to 0x00.

## CHAPTER 34 ON-CHIP DEBUG FUNCTION

The on-chip debug function of the V850E/SJ3-H and V850E/SK3-H can be implemented by the following two methods.

- Using the DCU (debug control unit)

On-chip debug function is implemented by the on-chip DCU in the V850E/SJ3-H and V850E/SK3-H, with using the  $\overline{\text{DRST}}$ , DCK, DMS, DDI, and DDO pins as the debug interface pins.

<R>

- Not using the DCU

On-chip debug function is implemented by MINICUBE2 or the like, using the user resources, instead of the DCU.

The following table shows the features of the two on-chip debug functions.

<R>

**Table 34-1. On-Chip Debug Function Features**

		Debugging Using DCU	Debugging Without Using DCU
Debug interface pins		$\overline{\text{DRST}}$ , DCK, DMS, DDI, DDO	<ul style="list-style-type: none"> <li>• When UAR<sub>TA0</sub> is used RXDA0, TXDA0</li> <li>• When CSIB<sub>0</sub> is used SIB<sub>0</sub>, SOB<sub>0</sub>, <math>\overline{\text{SCKB}}_0</math>, HS (PCM<sub>0</sub>)</li> <li>• When CSIB<sub>3</sub> is used SIB<sub>3</sub>, SOB<sub>3</sub>, <math>\overline{\text{SCKB}}_3</math>, HS (PCM<sub>0</sub>)</li> </ul>
Securement of user resources		Not required	Required
Hardware break function		2 points	2 points
Software break function	Internal ROM area	8 points	8 points
	Internal RAM area	2000 points	2000 points
Real-time RAM monitor function <sup>Note 1</sup>		Available	Available
Dynamic memory modification (DMM) function <sup>Note 2</sup>		Available	Available
Mask function		Reset, NMI, $\overline{\text{HLDRQ}}$ , $\overline{\text{WAIT}}$	$\overline{\text{RESET}}$ pin
ROM security function		10-byte ID code authentication	10-byte ID code authentication
Hardware used		IE-V850E1-CD-NW and NINICUBE <sup>®</sup> , etc.	NINICUBE2, etc.
Trace function		Not supported.	Not supported.
Event function		Not supported.	Not supported.
Debug interrupt interface function (DBINT)		Not supported.	Not supported.

**Notes** 1. This is a function which reads out memory contents during program execution.

2. This is a function which rewrites RAM contents during program execution.

### 34.1 Debugging with DCU

Programs can be debugged using the debug interface pins ( $\overline{\text{DRST}}$ , DCK, DMS, DDI, and DDO) to connect the on-chip debug emulator (IE-V850E1-CD-NW and MINICUBE<sup>®</sup>).

#### 34.1.1 Connection circuit example

Figure 34-1. Circuit Connection Example When Debug Interface Pins Are Used for Communication Interface

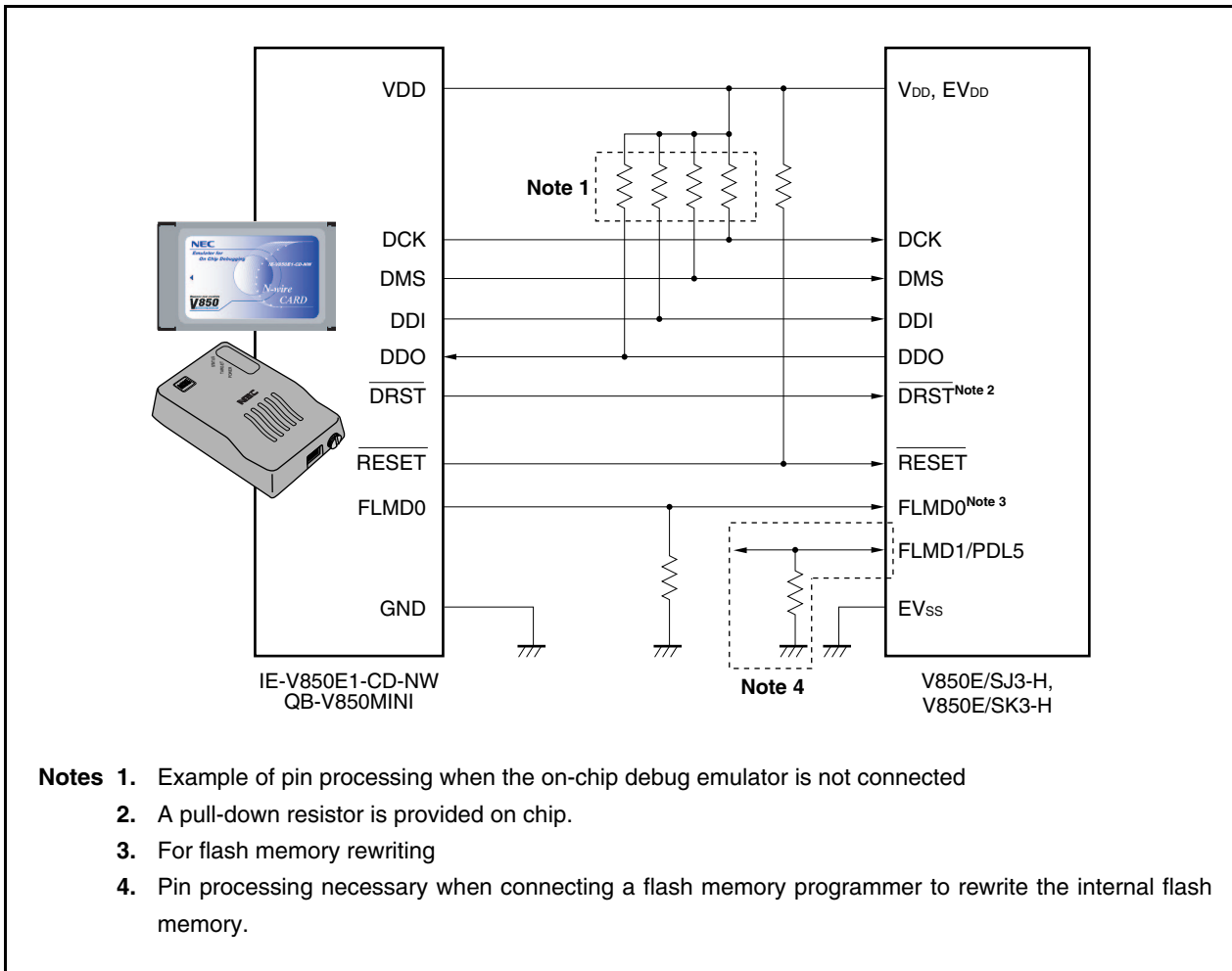

### 34.1.2 Interface signals

The interface signals are described below.

(1)  **$\overline{\text{DRST}}$**

This is a reset input signal for the on-chip debug unit. It is a negative-logic signal that asynchronously initializes the debug control unit.

The on-chip debug emulator raises the  $\overline{\text{DRST}}$  signal when it detects  $V_{\text{DD}}$  of the target system after the integrated debugger is started, and starts the on-chip debug unit of the device.

When the  $\overline{\text{DRST}}$  signal goes high, a reset signal is also generated in the CPU.

When starting debugging by starting the integrated debugger, a CPU reset is always generated.

(2) **DCK**

This is a clock input signal. It supplies a 20 MHz or 10 MHz clock from the on-chip debug emulator. In the on-chip debug unit, the DMS and DDI signals are sampled at the rising edge of the DCK signal, and the data DDO is output at its falling edge.

(3) **DMS**

This is a transfer mode select signal. The transfer status in the debug unit changes depending on the level of the DMS signal.

(4) **DDI**

This is a data input signal. It is sampled in the on-chip debug unit at the rising edge of DCK.

(5) **DDO**

This is a data output signal. It is output from the on-chip debug unit at the falling edge of the DCK signal.

(6)  **$V_{\text{DD}}$ ,  $E_{\text{VDD}}$**

This signal is used to detect  $V_{\text{DD}}$  of the target system. If  $V_{\text{DD}}$  from the target system is not detected, the signals output from the on-chip debug emulator ( $\overline{\text{DRST}}$ , DCK, DMS, DDI, FLMD0, and  $\overline{\text{RESET}}$ ) go into a high-impedance state.

**(7) FLMD0**

The flash self programming function is used for the function to download data to the flash memory via the integrated debugger. During flash self programming, the FLMD0 pin must be kept high. In addition, connect a pull-down resistor to the FLMD0 pin.

The FLMD0 pin can be controlled in either of the following two ways.

**<1> To control from on-chip debug emulator**

Connect the FLMD0 signal of the on-chip debug emulator to the FLMD0 pin.

In the normal mode, nothing is driven by the on-chip debug emulator (high impedance).

During a break, the on-chip debug emulator raises the FLMD0 pin to the high level when the download function of the integrated debugger is executed.

**<2> To control from port**

Connect any port of the device to the FLMD0 pin.

The same port as the one used by the user program to realize the flash self programming function may be used.

On the console of the integrated debugger, make a setting to raise the port pin to high level before executing the download function, or lower the port pin after executing the download function.

For details, refer to the **ID850QB (Integrated Debugger) Operation User's Manual**.

**(8)  $\overline{\text{RESET}}$** 

This is a system reset input pin. If the  $\overline{\text{DRST}}$  pin is made invalid by the value of the OCDM.OCDM0 bit set by the user program, on-chip debugging cannot be executed. Therefore, reset is effected by the on-chip debug emulator, using the  $\overline{\text{RESET}}$  pin, to make the  $\overline{\text{DRST}}$  pin valid (initialization).

&lt;R&gt;

**34.1.3 Maskable functions**

Reset, NMI,  $\overline{\text{WAIT}}$ , and  $\overline{\text{HLDRQ}}$  signals can be masked.

The maskable functions with the debugger (ID850QB) and the corresponding V850E/SJ3-H and V850E/SK3-H functions are listed below.

**Table 34-2. Maskable Functions**

Maskable Functions with ID850QB	Corresponding V850E/SJ3-H and V850E/SK3-H Functions
NMI0	NMI pin input
NMI2	—
STOP	—
HOLD	$\overline{\text{HLDRQ}}$ pin input
RESET	Reset signal (WDT2RES) generation by $\overline{\text{RESET}}$ pin input and watchdog timer overflow, reset signal (LVIRESET) generation by low-voltage detector (LVI), reset signal (CLMRES) generation by clock monitor (CLM)
WAIT	$\overline{\text{WAIT}}$ pin input

**34.1.4 Register****(1) On-chip debug mode register (OCDM)**

The OCDM register is used to select the normal operation mode or on-chip debug mode. This register is a special register and can be written only in a combination of specific sequences (see **3.4.8 Special registers**).

This register is also used to specify whether a pin provided with an on-chip debug function is used as an on-chip debug pin or as an ordinary port/peripheral function pin. It also is used to disconnect the internal pull-down resistor of the P05/INTP2/ $\overline{\text{DRST}}$  pin.

The OCDM register can be written only while a low level is input to the  $\overline{\text{DRST}}$  pin.

This register can be read or written in 8-bit or 1-bit units.

After reset: 01H<sup>Note</sup> R/W Address: FFFFF9FCH

	7	6	5	4	3	2	1	<0>
OCDM	0	0	0	0	0	0	0	OCDM0

OCDM0	Operation mode
0	Selects normal operation mode (in which a pin that functions alternately as on-chip debug function pin is used as a port/peripheral function pin) and disconnects the on-chip pull-down resistor of the P05/INTP2/ $\overline{DRST}$ pin.
1	When $\overline{DRST}$ pin is low: Normal operation mode (in which a pin that functions alternately as an on-chip debug function pin is used as a port/peripheral function pin) When $\overline{DRST}$ pin is high: On-chip debug mode (in which a pin that functions alternately as an on-chip debug function pin is used as an on-chip debug mode pin)

**Note** Reset by the  $\overline{RESET}$  pin sets this register to 01H. After reset by the overflow of watchdog timer (WDT2RES), reset (LVIRE) by the low-voltage detector (LVI), or reset (CLM) by the clock monitor (CLMRES), however, the value of the OCDM register is retained.

**Cautions** 1. When using the DDI, DDO, DCK, and DMS pins not as on-chip debug pins but as port pins after external reset, any of the following actions must be taken.

- Input a low level to the P05/INTP2/ $\overline{DRST}$  pin.
- Set the OCDM0 bit. In this case, take the following actions.
  - <1> Clear the OCDM0 bit to 0.
  - <2> Fix the P05/INTP2/ $\overline{DRST}$  pin to the low level until <1> is completed.

2. The  $\overline{DRST}$  pin has an on-chip pull-down resistor. This resistor is disconnected when the OCDM0 flag is cleared to 0.

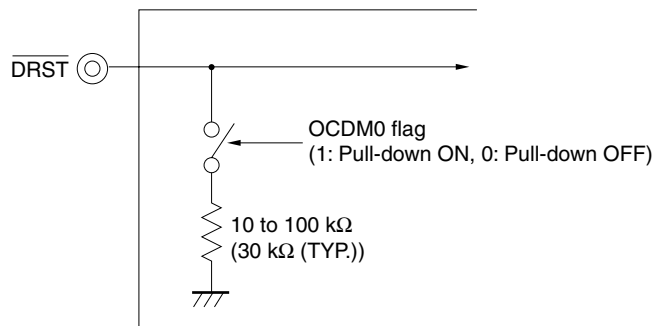



**34.1.5 Operation**

The on-chip debug function is made invalid under the conditions shown in the table below.

When this function is not used, keep the  $\overline{\text{DRST}}$  pin low until the OCDM.OCDM0 flag is cleared to 0.

OCDM0 Flag $\overline{\text{DRST}}$ Pin	0	1
L	Invalid	Invalid
H	Invalid	Valid

**Remark** L: Low-level input  
H: High-level input

**Figure 34-2. Timing When On-Chip Debug Function Is Not Used**

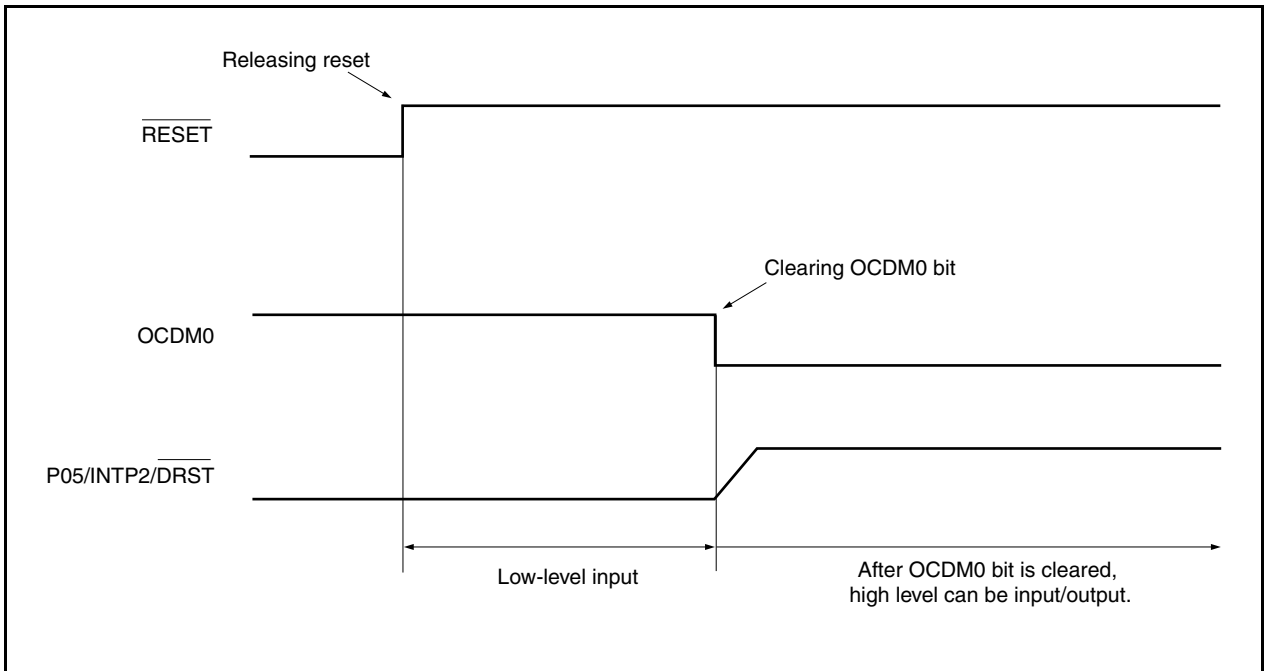

**34.1.6 Cautions**

- (1) If a reset signal is input (from the target system or a reset signal from an internal reset source) during RUN (program execution), the break function may malfunction.
- (2) Even if the reset signal is masked by the mask function, the I/O buffer (port pin) may be reset if a reset signal is input from a pin.
- (3) Pin reset during a break is masked and the CPU and peripheral I/O are not reset. If pin reset or internal reset is generated as soon as the flash memory is rewritten by DMM or read by the RAM monitor function while the user program is being executed, the CPU and peripheral I/O may not be correctly reset.
- (4) Emulation of ROM correction cannot be executed.
- (5) In the on-chip debug mode, the DDO pin is forcibly set to the high-level output.
- (6) Initialize the ASID register to 00H during on-chip debugging.

&lt;R&gt;

## 34.2 Debugging Without Using DCU

The following describes how to implement an on-chip debug function using MINICUBE2 with pins for UARTA0 (RXDA0 and TXDA0), pins for CSIB0 (SIB0, SOB0, SCKB0, and HS (PCM0)), or pins for CSIB3 (SIB3, SOB3, SCKB3, and HS (PCM0)) as debug interfaces, without using the DCU.

### 34.2.1 Circuit connection examples

Figure 34-3. Circuit Connection Example When UARTA0/CSIB0/CSIB3 Is Used for Communication Interface

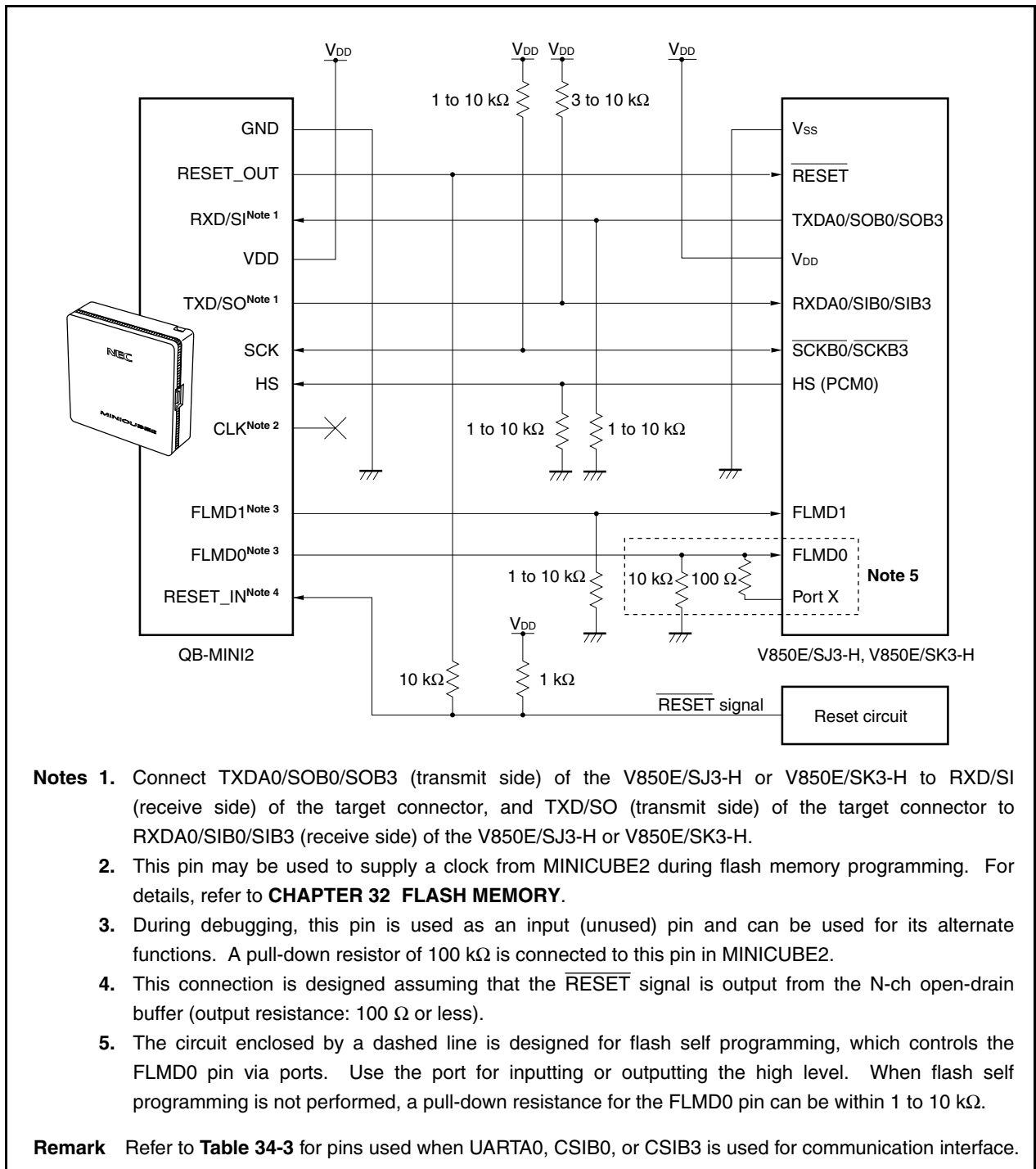

Table 34-3. Wiring Between V850E/SJ3-H, V850E/SK3-H, and MINICUBE2

Pin Configuration of MINICUBE2 (QB-MINI2)			With CSIB0-HS			With CSIB3-HS			With UARTA0		
Signal Name	I/O	Pin Function	Pin Name	Pin No.		Pin Name	Pin No.		Pin Name	Pin No.	
				SJ3-H	SK3-H		SJ3-H	SK3-H		SJ3-H	SK3-H
				GJ	GM		GJ	GM		GJ	GM
SI/RxD	Input	Pin to receive commands and data from V850E/SJ3-H and V850E/SK3-H	P41/SOB0	23	25	P911/SOB3	72	88	P30/TXDA0	25	30
SO/TxD	Output	Pin to transmit commands and data to V850E/SJ3-H and V850E/SK3-H	P40/SIB0	22	24	P910/SIB3	71	87	P31/RXDA0	26	31
SCK	Output	Clock output pin for 3-wire serial communication	P42/ $\overline{\text{SCKB0}}$	24	26	P912/ $\overline{\text{SCKB3}}$	73	89	Not needed	–	–
CLK <sup>Note</sup>	Output	Clock output pin to V850E/SJ3-H and V850E/SK3-H	Not needed <sup>Note</sup>	–	–	Not needed <sup>Note</sup>	–	–	Not needed <sup>Note</sup>	–	–
RESET_OUT	Output	Reset output pin to V850E/SJ3-H and V850E/SK3-H	$\overline{\text{RESET}}$	14	16	$\overline{\text{RESET}}$	14	16	$\overline{\text{RESET}}$	14	16
FLMD0	Output	Output pin to set V850E/SJ3-H and V850E/SK3-H to debug mode or programming mode	FLMD0	8	10	FLMD0	8	10	FLMD0	8	10
FLMD1	Output	Output pin to set programming mode	PLD5/FLMD1	110	134	PLD5/FLMD1	110	134	PLD5/FLMD1	110	134
HS	Input	Handshake signal for CS10 + HS communication	PCM0	85	105	PCM0	85	105	Not needed	–	–
GND	–	Ground	V <sub>SS</sub>	11	13	V <sub>SS</sub>	11	13	V <sub>SS</sub>	11	13
RESET_IN	Input	Reset input pin on the target system									

**Note** It is used as the clock output of the flash programmer for MINICUBE2. For details, refer to **CHAPTER 32 FLASH MEMORY**.

**Remark** SJ3-H: V850E/SJ3-H  
SK3-H: V850E/SK3-H  
GJ (V850E/SJ3-H): 144-pin plastic LQFP (fine pitch) (20 × 20)  
GM (V850E/SK3-H): 176-pin plastic LQFP (fine pitch) (24 × 24)

### 34.2.2 Maskable functions

Only reset signals can be masked.

The functions that can be masked with the debugger (ID850QB) and the corresponding functions of the V850E/SJ3-H and V850E/SK3-H are listed below.

**Table 34-4. Maskable Functions**

Maskable Functions with ID850QB	Corresponding V850E/SJ3-H and V850E/SK3-H Functions
NMI0	–
NMI1	–
NMI2	–
STOP	–
HOLD	–
RESET	Reset signal generation by $\overline{\text{RESET}}$ pin input
WAIT	–

### 34.2.3 Securement of user resources

The user must prepare the following to perform communication between MINICUBE2 and the target device and implement each debug function. These items need to be set in the user program or using the compiler options.

#### (1) Securement of memory space

The shaded portions in Figure 34-4 are the areas reserved for placing the debug monitor program, so user programs and data cannot be allocated in these spaces. These spaces must be secured so as not to be used by the user program.

#### (2) Security ID setting

The ID code must be embedded in the area between 0000070H and 0000079H in Figure 34-4, to prevent the memory from being read by an unauthorized person. For details, refer to **34.3 ROM Security Function**.

Figure 34-4. Memory Spaces Where Debug Monitor Programs Are Allocated

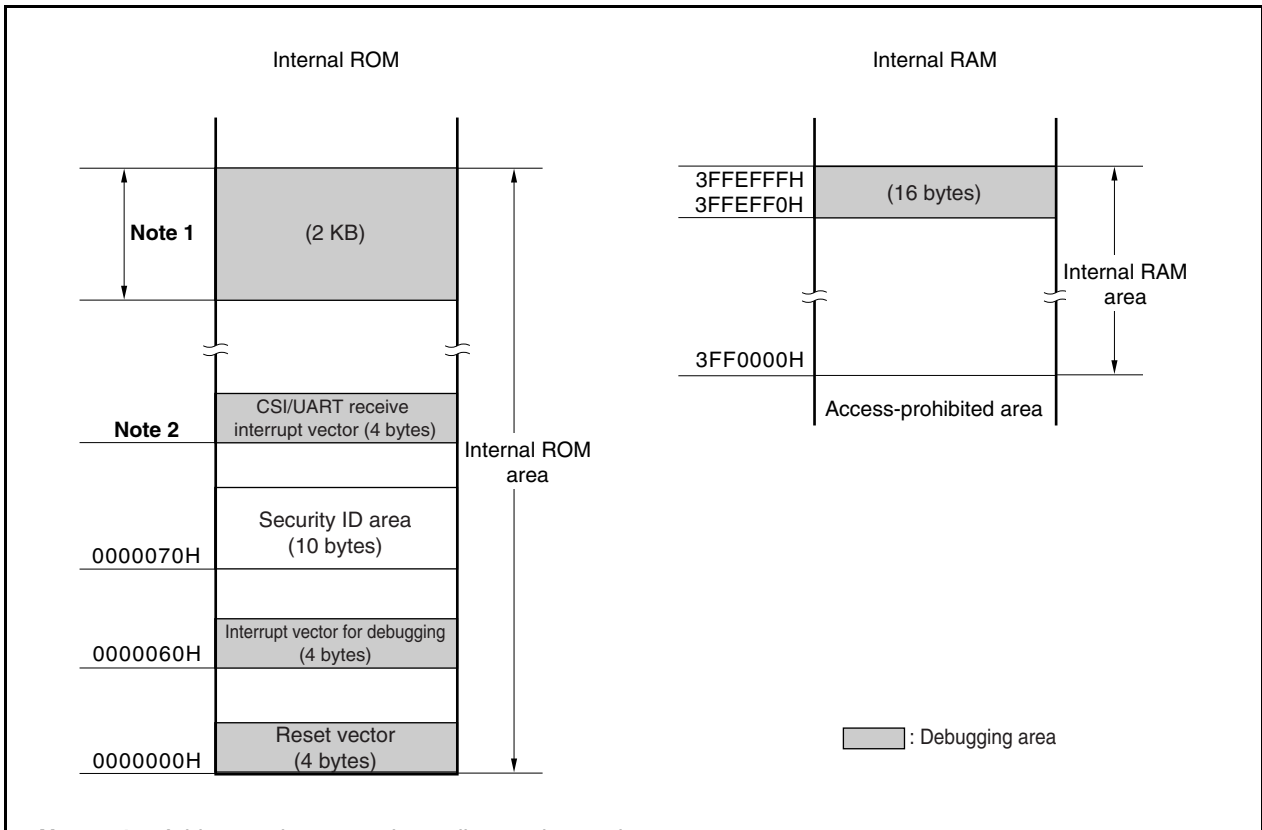

Notes 1. Address values vary depending on the product.

	Internal ROM Size	Address Value
$\mu$ PD70F3931 (V850E/SJ3-H), 70F3932 (V850E/SJ3-H), 70F3933 (V850E/SJ3-H)	512 KB	007F800H to 007FFFFH
$\mu$ PD70F3934 (V850E/SJ3-H), 70F3935 (V850E/SJ3-H), 70F3936 (V850E/SJ3-H)	768 KB	00BF800H to 00BFFFFH
$\mu$ PD70F3925 (V850E/SK3-H), 70F3926 (V850E/SK3-H), 70F3927 (V850E/SK3-H), 70F3937 (V850E/SJ3-H), 70F3938 (V850E/SJ3-H), 70F3939 (V850E/SJ3-H)	1024 KB	00FF800H to 00FFFFFFH
$\mu$ PD70F3474 (V850E/SJ3-H), 70F3475 (V850E/SJ3-H), 70F3476 (V850E/SJ3-H), 70F3486 (V850E/SK3-H), 70F3487 (V850E/SK3-H), 70F3488 (V850E/SK3-H)	1280 KB	013F800H to 013FFFFH
$\mu$ PD70F3477 (V850E/SJ3-H), 70F3478 (V850E/SJ3-H), 70F3479 (V850E/SJ3-H), 70F3480 (V850E/SK3-H), 70F3481 (V850E/SK3-H), 70F3482 (V850E/SK3-H)	1536 KB	017F800H to 017FFFFH

2. When UARTA0 is used, when CSIB0 is used, and when CSIB3 is used, the start address value is as follows:

Target Serial Interface	Internal RAM Size	Address Value
UARTA0	INTUA0R	0000310H
CSIB0	INTCB0R	0000290H
CSIB3	INTCB3R	00002F0H

**(3) Reset vector**

A reset vector includes the jump instruction for the debug monitor program.

[How to secure areas]

It is not necessary to secure this area intentionally. When downloading a program, however, the debugger rewrites the reset vector in accordance with the following cases. If the rewritten pattern does not match the following cases, the debugger generates an error (FOC34 when using the ID850QB).

**(a) When two nop instructions are placed in succession from address 0**

Before rewriting		After rewriting
0x0 nop	→	Jumps to debug monitor program at 0x0
0x2 nop		0x4 xxxx
0x4 xxxx		

**(b) When two 0xFFFF are successively placed from address 0 (already erased device)**

Before rewriting		After rewriting
0x0 0xFFFF	→	Jumps to debug monitor program at 0x0
0x2 0xFFFF		0x4 xxxx
0x4 xxxx		

**(c) The jr instruction is placed at address 0 (when using CA850)**

Before rewriting		After rewriting
0x0 jr disp22	→	Jumps to debug monitor program at 0x0
		0x4 jr disp22 - 4

**(d) mov32 and jmp are placed in succession from address 0 (when using IAR compiler ICCV850)**

Before rewriting		After rewriting
0x0 mov imm32,reg1	→	Jumps to debug monitor program at 0x0
0x6 jmp [reg1]		0x4 mov imm32,reg1
		0xa jmp [reg1]

**(e) The jump instruction for the debug monitor program is placed at address 0**

Before rewriting		After rewriting
Jumps to debug monitor program at 0x0	→	No change



**(4) Securement of area for debug monitor program**

The shaded portions in Figure 34-4 are the areas where the debug monitor program is allocated. The monitor program performs initialization processing for debug communication interface and RUN or break processing for the CPU. The internal ROM area must be filled with 0xFF. This area must not be rewritten by the user program.

[How to secure areas]

It is not necessarily required to secure this area if the user program does not use this area.

To avoid problems that may occur during the debugger startup, however, it is recommended to secure this area in advance, using the compiler.

The following shows examples for securing the area, using the NEC Electronics compiler CA850. Add the assemble source file and link directive code, as shown below.

- Assemble source (Add the following code as an assemble source file.)

```

-- Secures 2 KB space for monitor ROM section
.section "MonitorROM", const
.space 0x800, 0xff

-- Secures interrupt vector for debugging
.section "DBG0"
.space 4, 0xff

-- Secures interrupt vector for serial communication
-- Change the section name according to the serial communication mode used
.section "INTCB0R"
.space 4, 0xff

-- Secures 16-byte space for monitor RAM section
.section "MonitorRAM", bss
.lcomm monitorramsym, 16, 4 -- defines symbol monitorramsym

```

- Link directive (Add the following code to the link directive file.)

The following shows an example when the internal ROM has 512 KB (end address is 007FFFFH) and internal RAM has 60 KB (end address is 3FFEFFFH).

```

MROMSEG      : !LOAD ?R V0x07f800{
              MonitorROM = $PROGBITS ?A MonitorROM;
};

MRAMSEG      : !LOAD ?RW V0x03ffeff0{
              MonitorRAM = $NOBITS ?AW MonitorRAM;
};

```

**(5) Securement of communication serial interface**

UARTA0, CSIB0, or CSIB3 is used for communication between MINICUBE2 and the target system. The settings related to the serial interface modes are performed by the debug monitor program, but if the setting is changed by the user program, a communication error may occur.

To prevent such a problem from occurring, communication serial interface must be secured in the user program.

[How to secure communication serial interface]

- On-chip debug mode register (OCDM)
 

For the on-chip debug function using the UARTA0, CSIB0, or CSIB3, set the OCDM register functions to normal mode. Be sure to set as follows.

  - Input low level to the P05/INTP2/ $\overline{\text{DRST}}$  pin.
  - Set the OCDM0 bit as shown below.
    - <1> Clear the OCDM0 bit to 0.
    - <2> Fix the P05/INTP2/ $\overline{\text{DRST}}$  pin input to low level until the processing of <1> is complete.
- Serial interface registers
 

Do not set the registers related to CSIB0, CSIB3, or UARTA0 in the user program.
- Interrupt mask register
 

When CSIB0 is used, do not mask the reception completion interrupt (INTCB0R). When CSIB3 is used, do not mask the reception completion interrupt (INTCB3R). When UARTA0 is used, do not mask the reception completion interrupt (INTUA0R).

<b>(a) When CSIB0 is used</b>								
	7	6	5	4	3	2	1	0
CB0RIC	×	0	×	×	×	×	×	×
<b>(b) When CSIB3 is used</b>								
	7	6	5	4	3	2	1	0
CB3RIC	×	0	×	×	×	×	×	×
<b>(c) When UARTA0 is used</b>								
	7	6	5	4	3	2	1	0
UA0RIC	×	0	×	×	×	×	×	×
<b>Remark</b> ×: don't care								

- Port registers when UARTA0 is used

When UARTA0 is used, port registers are set to make the TXDA0 and RXDA0 pins valid by the debug monitor program. Do not change the following register settings with the user program during debugging. (The same value can be overwritten.)

	7	6	5	4	3	2	1	0
PFC3	×	×	×	×	×	×	0	0
	7	6	5	4	3	2	1	0
PFCE3	×	×	×	×	×	×	0	0
	7	6	5	4	3	2	1	0
PMC3	×	×	×	×	×	×	1	1

**Remark** ×: don't care

- Port registers when CSIB0 is used

When CSIB0 is used, port registers are set to make the SIB0, SOB0,  $\overline{\text{SCKB0}}$ , and HS (PCM0) pins valid by the debug monitor program. Do not change the following register settings with the user program during debugging. (The same value can be overwritten.)

**(a) SIB0, SOB0, and  $\overline{\text{SCKB0}}$  settings**

	7	6	5	4	3	2	1	0
PMC4	×	×	×	×	×	1	1	1
	7	6	5	4	3	2	1	0
PFC4	×	×	×	×	×	0	0	0

**(b) HS (PCM0 pin) settings**

	7	6	5	4	3	2	1	0
PMCCM	0	0	0	0	×	×	×	0
	7	6	5	4	3	2	1	0
PMCM	1	1	×	×	×	×	×	0
	7	6	5	4	3	2	1	0
PCM	0	0	×	×	×	×	×	<b>Note</b>

**Note** Writing to this bit is prohibited.  
The port values corresponding to the HS pin are changed by the monitor program according to the debugger status. To perform port register settings in 8-bit units, the user program can usually use read-modify-write. If an interrupt for debugging occurs before writing, however, an unexpected operation may be performed.

**Remark** ×: don't care

- Port registers when CSIB3 is used

When CSIB3 is used for communication, port registers are set to make the SIB3, SOB3,  $\overline{\text{SCKB3}}$ , and HS (PCM0) pins valid by the debug monitor program. Do not change the following register settings with the user program during debugging. (The same value can be overwritten.)

**(a) SIB3, SOB3, and  $\overline{\text{SCKB3}}$  settings**

	15	14	13	12	11	10	9	8
PMC9H	×	×	×	1	1	1	×	×

	15	14	13	12	11	10	9	8
PFC9H	×	×	×	1	1	1	×	×

	15	14	13	12	11	10	9	8
PFCE9H	×	×	0	0	0	0	0	0

**(b) HS (PCM0 pin) settings**

	7	6	5	4	3	2	1	0
PMCCM	0	0	0	0	×	×	×	0

	7	6	5	4	3	2	1	0
PMCM	1	1	×	×	×	×	×	0

	7	6	5	4	3	2	1	0
PCM	0	0	×	×	×	×	×	<b>Note</b>

**Note** Writing to this bit is prohibited.

The port values corresponding to the HS pin are changed by the monitor program according to the debugger status. To perform port register settings in 8-bit units, the user program can usually use read-modify-write. If an interrupt for debugging occurs before writing, however, an unexpected operation may be performed.

**Remark** ×: don't care

### 32.2.4 Cautions

**(1) Handling of device that was used for debugging**

Do not mount a device that was used for debugging on a mass-produced product, because the flash memory was rewritten during debugging and the number of rewrites of the flash memory cannot be guaranteed. Moreover, do not embed the debug monitor program into mass-produced products.

**(2) When breaks cannot be executed**

Forced breaks cannot be executed if one of the following conditions is satisfied.

- Interrupts are disabled (DI)
- Interrupts issued for the serial interface, which is used for communication between MINICUBE2 and the target device, are masked
- Standby mode is entered while standby release by a maskable interrupt is prohibited
- Mode for communication between MINICUBE2 and the target device is UARTA0, and the main clock has been stopped

**(3) When pseudo real-time RAM monitor (RRM) function and DMM function do not operate**

The pseudo RRM function and DMM function do not operate if one of the following conditions is satisfied.

- Interrupts are disabled (DI)
- Interrupts issued for the serial interface, which is used for communication between MINICUBE2 and the target device, are masked
- Standby mode is entered while standby release by a maskable interrupt is prohibited
- Mode for communication between MINICUBE2 and the target device is UARTA0, and the main clock has been stopped
- Mode for communication between MINICUBE2 and the target device is UARTA0, and a clock different from the one specified in the debugger is used for communication

**(4) Standby release with pseudo RRM and DMM functions enabled**

The standby mode is released by the pseudo RRM function and DMM function if one of the following conditions is satisfied.

- Mode for communication between MINICUBE2 and the target device is CSIB0 or CSIB3
- Mode for communication between MINICUBE2 and the target device is UARTA0, and the main clock has been supplied.

**(5) Rewriting to peripheral I/O registers that requires a specific sequence, using DMM function**

Peripheral I/O registers that requires a specific sequence cannot be rewritten with the DMM function.

**(6) Flash self programming**

If a space where the debug monitor program is allocated is rewritten by flash self programming, the debugger can no longer operate normally.

### 34.3 ROM Security Function

#### 34.3.1 Security ID

The flash memory versions of the V850E/SJ3-H and V850E/SK3-H perform authentication using a 10-byte ID code to prevent the contents of the flash memory from being read by an unauthorized person during on-chip debugging by the on-chip debug emulator.

Set the ID code in the 10-byte on-chip flash memory area from 0000070H to 0000079H to allow the debugger perform ID authentication.

If the IDs match, the security is released and reading flash memory and using the on-chip debug emulator are enabled.

- Set the 10-byte ID code to 0000070H to 0000079H.
- Bit 7 of 0000079H is the on-chip debug emulator enable flag (0: Disable, 1: Enable).
- When the on-chip debug emulator is started, the debugger requests ID input. When the ID code input on the debugger and the ID code set in 0000070H to 0000079H match, the debugger starts.
- Debugging cannot be performed if the on-chip debug emulator enable flag is 0, even if the ID codes match.

Figure 34-5. Security ID Area

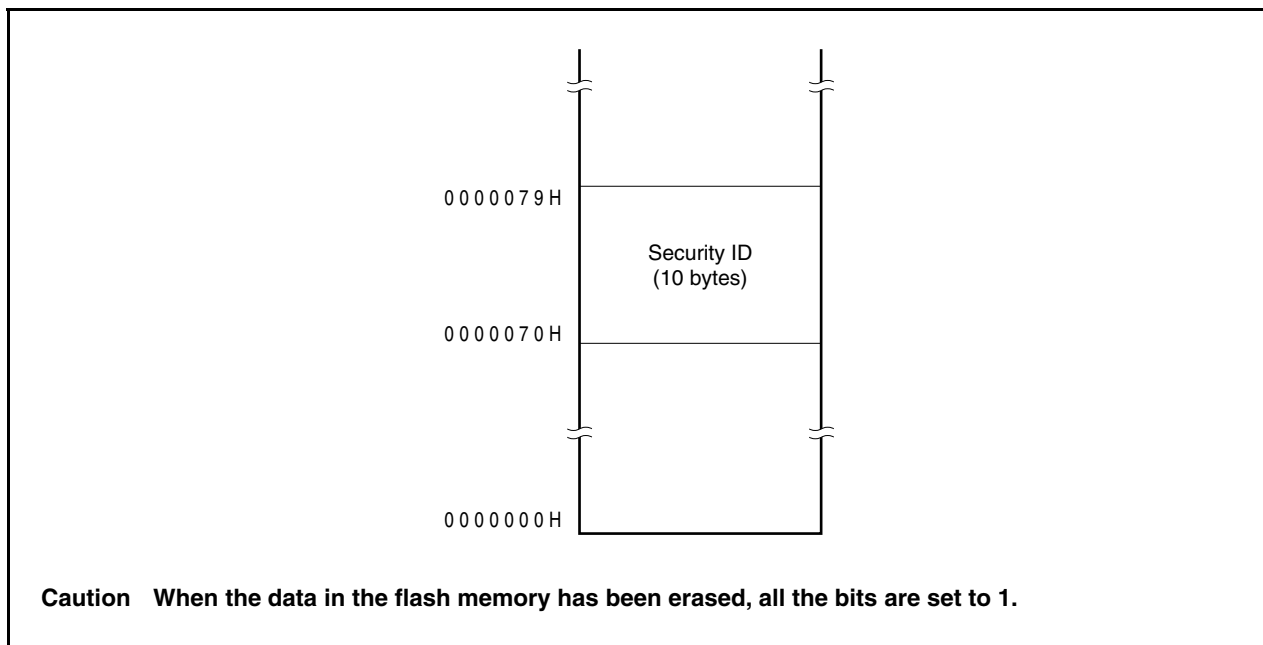

### 34.3.2 Setting

The following shows how to set the ID code as shown in Table 34-5.

When the ID code is set as shown in Table 34-5, the ID code input in the configuration dialog box of the ID850QB is "123456789ABCDEF123D4" (the ID code is case-insensitive).

**Table 34-5. ID Code**

Address	Value
0x70	0x12
0x71	0x34
0x72	0x56
0x73	0x78
0x74	0x9A
0x75	0xBC
0x76	0xDE
0x77	0XF1
0x78	0x23
0x79	0xD4

The ID code can be specified for the device file that supports CA850 Ver. 3.10 or later and the security ID using the PM+ compiler common option setting.

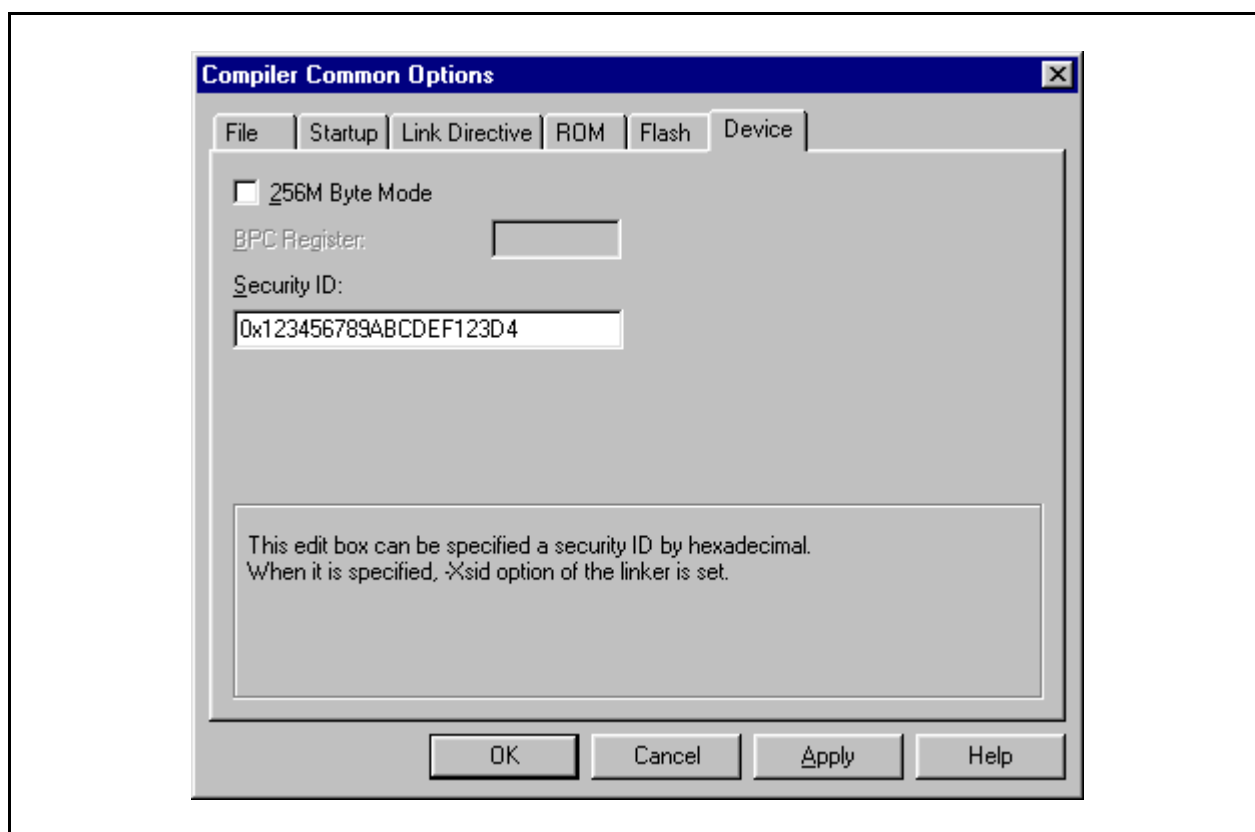

[Program example (when using CA850 Ver. 3.10 or later)]

```
#-----  
# SECURITYID  
#-----  
    .section "SECURITY_ID" --Interrupt handler address 0x70  
    .word    0x78563412    --0-3 byte code  
    .word    0xF1DEBC9A    --4-7 byte code  
    .hword   0xD423        --8-9 byte code
```

**Remark** Add the above program example to the startup files.



## CHAPTER 35 ELECTRICAL SPECIFICATIONS

### 35.1 Absolute Maximum Ratings

(T<sub>A</sub> = 25°C) (1/2)

Parameter	Symbol	Conditions	Ratings	Unit
Supply voltage	V <sub>DD</sub>	V <sub>DD</sub> = EV <sub>DD</sub> = AV <sub>REF0</sub> = AV <sub>REF1</sub>	-0.5 to +4.6	V
	BV <sub>DD</sub>		-0.5 to +4.6	V
	EV <sub>DD</sub>	V <sub>DD</sub> = EV <sub>DD</sub> = AV <sub>REF0</sub> = AV <sub>REF1</sub>	-0.5 to +4.6	V
	AV <sub>REF0</sub>	V <sub>DD</sub> = EV <sub>DD</sub> = AV <sub>REF0</sub> = AV <sub>REF1</sub>	-0.5 to +4.6	V
	AV <sub>REF1</sub>	V <sub>DD</sub> = EV <sub>DD</sub> = AV <sub>REF0</sub> = AV <sub>REF1</sub>	-0.5 to +4.6	V
	V <sub>SS</sub>	V <sub>SS</sub> = EV <sub>SS</sub> = BV <sub>SS</sub> = AV <sub>SS</sub>	-0.5 to +0.5	V
	AV <sub>SS</sub>	V <sub>SS</sub> = EV <sub>SS</sub> = BV <sub>SS</sub> = AV <sub>SS</sub>	-0.5 to +0.5	V
	BV <sub>SS</sub>	V <sub>SS</sub> = EV <sub>SS</sub> = BV <sub>SS</sub> = AV <sub>SS</sub>	-0.5 to +0.5	V
	EV <sub>SS</sub>	V <sub>SS</sub> = EV <sub>SS</sub> = BV <sub>SS</sub> = AV <sub>SS</sub>	-0.5 to +0.5	V
Input voltage	V <sub>I1</sub>	$\overline{\text{RESET}}$ , FLMD0	-0.5 to EV <sub>DD</sub> + 0.5 <sup>Note 1</sup>	V
	V <sub>I2</sub>	<b>Note 3</b>	-0.5 to BV <sub>DD</sub> + 0.5 <sup>Note 1</sup>	V
	V <sub>I3</sub>	P10, P11	-0.5 to AV <sub>REF1</sub> + 0.5 <sup>Note 1</sup>	V
	V <sub>I4</sub>	X1, X2	-0.5 to V <sub>RO</sub> <sup>Note 2</sup> + 0.5 <sup>Note 1</sup>	V
	V <sub>I5</sub>	<b>Note 4</b>	-0.5 to +6.0	V
	V <sub>I6</sub>	XT1, XT2	-0.5 to V <sub>DD</sub> + 0.5 <sup>Note 1</sup>	V
	Analog input voltage	V <sub>IAN</sub>	P70 to P715	-0.5 to AV <sub>REF0</sub> + 0.5 <sup>Note 1</sup>

- Notes**
- Be sure not to exceed the absolute maximum ratings (MAX. value) of each supply voltage.
  - On-chip regulator output voltage (2.5 V (TYP.))
  - V850E/SJ3-H: PCD0 to PCD3, PCM0 to PCM5, PCS0 to PCS7, PCT0 to PCT7, PDL0 to PDL15, PDH0 to PDH7  
 V850E/SK3-H: P130 to P133, P140 to P145, PCD0 to PCD3, PCM0 to PCM5, PCS0 to PCS7, PCT0 to PCT7, PDL0 to PDL15, PDH0 to PDH7
  - V850E/SJ3-H: P00 to P06, P30 to P39, P40 to P42, P50 to P55, P60 to P615, P80, P81, P90 to P915  
 V850E/SK3-H: P00 to P06, P20, P21, P30 to P312, P40 to P45, P50 to P57, P60 to P615, P80 to P85, P90 to P915, P150 to P153

(T<sub>A</sub> = 25°C) (2/2)

Parameter	Symbol	Conditions	Ratings	Unit	
Output current, low	I <sub>OL</sub>	<b>Note 1</b>	Per pin	4	mA
			Total of all pins	50	mA
		<b>Note 2</b>	Per pin	4	mA
			Total of all pins	50	mA
		P10, P11	Per pin	4	mA
			Total of all pins	8	mA
		P70 to P715	Per pin	4	mA
			Total of all pins	20	mA
Output current, high	I <sub>OH</sub>	<b>Note 1</b>	Per pin	-4	mA
			Total of all pins	-50	mA
		<b>Note 2</b>	Per pin	-4	mA
			Total of all pins	-50	mA
		P10, P11	Per pin	-4	mA
			Total of all pins	-8	mA
		P70 to P715	Per pin	-4	mA
			Total of all pins	-20	mA
Operating ambient temperature	T <sub>A</sub>		-40 to +85	°C	
Storage temperature	T <sub>stg</sub>		-40 to +125	°C	

- Notes**
- V850E/SJ3-H: P00 to P06, P30 to P39, P40 to P42, P50 to P55, P60 to P615, P80, P81, P90 to P915  
V850E/SK3-H: P00 to P06, P20, P21, P30 to P312, P40 to P45, P50 to P57, P60 to P615, P80 to P85, P90 to P915, P150 to P153
  - V850E/SJ3-H: PCD0 to PCD3, PCM0 to PCM5, PCS0 to PCS7, PCT0 to PCT7, PDL0 to PDL15, PDH0 to PDH7  
V850E/SK3-H: P130 to P133, P140 to P145, PCD0 to PCD3, PCM0 to PCM5, PCS0 to PCS7, PCT0 to PCT7, PDL0 to PDL15, PDH0 to PDH7

- Cautions**
- Do not directly connect the output (or I/O) pins of IC products to each other, or to V<sub>DD</sub>, V<sub>CC</sub>, and GND. Open-drain pins or open-collector pins, however, can be directly connected to each other. Direct connection of the output pins between an IC product and an external circuit is possible, if the output pins can be set to the high-impedance state and the output timing of the external circuit is designed to avoid output conflict.
  - Product quality may suffer if the absolute maximum rating is exceeded even momentarily for any parameter. That is, the absolute maximum ratings are rated values at which the product is on the verge of suffering physical damage, and therefore the product must be used under conditions that ensure that the absolute maximum ratings are not exceeded. The ratings and conditions indicated for DC characteristics and AC characteristics represent the quality assurance range during normal operation.

**Remark** Unless specified otherwise, the characteristics of alternate-function pins are the same as those of port pins.

### 35.2 Capacitance

( $T_A = 25^\circ\text{C}$ ,  $V_{DD} = EV_{DD} = BV_{DD} = AV_{REF0} = AV_{REF1} = V_{SS} = EV_{SS} = BV_{SS} = AV_{SS} = 0\text{ V}$ )

Parameter	Symbol	Conditions	MIN.	TYP.	MAX.	Unit
I/O capacitance	$C_{io}$	$f_x = 1\text{ MHz}$ Unmeasured pins returned to 0 V			10	pF

### 35.3 Operating Conditions

( $T_A = -40\text{ to }+85^\circ\text{C}$ ,  $BV_{DD} \leq V_{DD} = EV_{DD} = AV_{REF0} = AV_{REF1}$ ,  $V_{SS} = EV_{SS} = BV_{SS} = AV_{SS} = 0\text{ V}$ )

Internal System Clock Frequency	Conditions	Supply Voltage				Unit
		$V_{DD}$	$EV_{DD}$	$BV_{DD}$	$AV_{REF0}$ , $AV_{REF1}$	
$f_{xx} = 3.0\text{ to }48\text{ MHz}$	$C = 4.7\ \mu\text{F}$ , A/D converter stopped, D/A converter stopped	2.85 to 3.6	2.85 to 3.6	2.7 to 3.6	2.85 to 3.6	V
	$C = 4.7\ \mu\text{F}$ , A/D converter operating, D/A converter operating	3.0 to 3.6	3.0 to 3.6	2.7 to 3.6	3.0 to 3.6	V
$f_{xt} = 32.768\text{ kHz}$	$C = 4.7\ \mu\text{F}$ , A/D converter stopped, D/A converter stopped	2.85 to 3.6	2.85 to 3.6	2.7 to 3.6	2.85 to 3.6	V

## 35.4 Oscillator Characteristics

### 35.4.1 Main clock oscillator characteristics

( $T_A = -40$  to  $+85^\circ\text{C}$ ,  $BV_{DD} \leq V_{DD} = EV_{DD} = AV_{REF0} = AV_{REF1}$ ,  $V_{SS} = EV_{SS} = BV_{SS} = AV_{SS} = 0\text{ V}$ )

Resonator	Circuit Example	Parameter	Conditions	MIN.	TYP.	MAX.	Unit
Ceramic resonator/ Crystal resonator		Oscillation frequency ( $f_x$ ) <sup>Note 1</sup>		3.0		10	MHz
		Oscillation stabilization time <sup>Note 2</sup>	After reset is released		$2^{16}/f_x$		s
			After STOP mode is released	$1$ <sup>Note 4</sup>	<b>Note 3</b>		ms
After IDLE2 mode is released	$350$ <sup>Note 4</sup>	<b>Note 3</b>		$\mu\text{s}$			

**Notes** 1. The oscillation frequency shown above indicates only oscillator characteristics. Use the V850E/SJ3-H and V850E/SK3-H so that the internal operation conditions do not exceed the ratings shown in **AC Characteristics** and **DC Characteristics**.

2. Time required from start of oscillation until the resonator stabilizes.
3. The value varies depending on the setting of the OSTS register.
4. Time required to set up the flash memory. Secure the setup time using the OSTS register.

**Cautions** 1. When using the main clock oscillator, wire as follows in the area enclosed by the broken lines in the above figure to avoid an adverse effect from wiring capacitance.

- Keep the wiring length as short as possible.
  - Do not cross the wiring with the other signal lines.
  - Do not route the wiring near a signal line through which a high fluctuating current flows.
  - Always make the ground point of the oscillator capacitor the same potential as  $V_{SS}$ .
  - Do not ground the capacitor to a ground pattern through which a high current flows.
  - Do not fetch signals from the oscillator.
2. When the main clock is stopped and the device is operating on the subclock, wait until the oscillation stabilization time has been secured by the program before switching back to the main clock.
  3. For the resonator selection and oscillator constant, customers are requested to either evaluate the oscillation themselves or apply to the resonator manufacturer for evaluation.

(i) KYOCERA KINSEKI CORPORATION: Crystal resonator (T<sub>A</sub> = -40 to +85°C)

Manufacturer (Part Number)	Circuit Example	Oscillation Frequency f <sub>x</sub> (kHz)	Recommended Circuit Constant			Oscillation Voltage Range	
			C1 (pF)	C2 (pF)	Rd (kΩ)	MIN. (V)	MAX. (V)
KYOCERA KINSEKI CORPORATION - CX-5FD (capacitance : 8 pF) - CX-49G (capacitance : 8 pF) - HC-49/U-S (capacitance : 8 pF) About other resonator's type name, refer to the resonator manufacturer.		4,000	8	8	–	2.85	3.6
		5,000	8	8	–	2.85	3.6
		8,000	8	8	–	2.85	3.6
		10,000	8	8	–	2.85	3.6
		3,145.72	8	8	–	2.85	3.6
		4,718.592	8	8	–	2.85	3.6
		6,291.456	8	8	–	2.85	3.6

**Caution** This oscillator constant is a reference value based on evaluation under a specific environment by the resonator manufacturer.

If optimization of oscillator characteristics is necessary in the actual application, apply to the resonator manufacturer for evaluation on the implementation circuit.

The oscillation voltage and oscillation frequency indicate only oscillator characteristics. Use the V850E/SJ3-H and V850E/SK3-H so that the internal operating conditions are within the specifications of the DC and AC characteristics.

**Remark** Contact:

KYOCERA Electronic components & devices <http://global.kyocera.com/prdct/electro/index.html>

Resonator vs. IC matching search <http://www3.kyocera.co.jp/electro/app/en/searchTopShow.do>

(ii) Toyama Murata Mfg. Co. Ltd.: Ceramic resonator ( $T_A = -40$  to  $+125^\circ\text{C}$ )

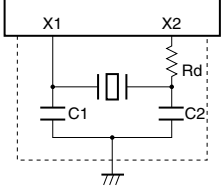
Manufacturer	Circuit Example	Oscillation Frequency $f_x$ (MHz)	Part Number	Recommended Circuit Constant			Oscillation Voltage Range	
				C1 (pF)	C2 (pF)	Rd (k $\Omega$ )	MIN. (V)	MAX. (V)
Toyama Murata Mfg. Co. Ltd.		3.000	CSTCC3M00G56A-R0	on-chip (47)	on-chip (47)	1	2.7	3.6
		4.000	CSTCR4M00G55B-R0	on-chip (39)	on-chip (39)	0.33	2.7	3.6
		5.000	CSTCR5M00G55B-R0	on-chip (39)	on-chip (39)	0	2.7	3.6
		6.000	CSTCR6M00G55B-R0	on-chip (39)	on-chip (39)	0	2.7	3.6
		8.000	CSTCE8M00G55A-R0	on-chip (33)	on-chip (33)	0	2.7	3.6
		10.000	CSTCE10M0G55A-R0	on-chip (33)	on-chip (33)	0	2.7	3.6

**Caution** This oscillator constant is a reference value based on evaluation under a specific environment by the resonator manufacturer.

If optimization of oscillator characteristics is necessary in the actual application, apply to the resonator manufacturer for evaluation on the implementation circuit.

The oscillation voltage and oscillation frequency indicate only oscillator characteristics. Use the V850E/SJ3-H and V850E/SK3-H so that the internal operating conditions are within the specifications of the DC and AC characteristics.

**Remark** Contact:

Engineering Section IV

Piezoelectric Components Department I

Toyama Murata Mfg. Co., Ltd.

TEL: +81-76-429-1995

E-mail: piezo@murata.co.jp

IC Part Number -> Ceramic Resonator Search: [http://search.murata.co.jp/Ceramy/CeMenu\\_en.do](http://search.murata.co.jp/Ceramy/CeMenu_en.do)

35.4.2 Subclock oscillator characteristics

( $T_A = -40$  to  $+85^\circ\text{C}$ ,  $BV_{DD} \leq V_{DD} = EV_{DD} = AV_{REF0} = AV_{REF1}$ ,  $V_{SS} = EV_{SS} = BV_{SS} = AV_{SS} = 0\text{ V}$ )

Resonator	Circuit Example	Parameter	Conditions	MIN.	TYP.	MAX.	Unit
Crystal resonator		Oscillation frequency ( $f_{XT}$ ) <sup>Note 1</sup>		32	32.768	35	kHz
		Oscillation stabilization time <sup>Note 2</sup>				10	s

**Notes 1.** The oscillation frequency shown above indicates only oscillator characteristics. Use the V850E/SJ3-H and V850E/SK3-H so that the internal operation conditions do not exceed the ratings shown in **AC Characteristics** and **DC Characteristics**.

**2.** Time required from when  $V_{DD}$  reaches the oscillation voltage range (2.85 V (MIN.)) to when the crystal oscillator stabilizes.

**Cautions 1.** When using the subclock oscillator, wire as follows in the area enclosed by the broken lines in the above figures to avoid an adverse effect from wiring capacitance.

- Keep the wiring length as short as possible.
  - Do not cross the wiring with the other signal lines.
  - Do not route the wiring near a signal line through which a high fluctuating current flows.
  - Always make the ground point of the oscillator capacitor the same potential as  $V_{SS}$ .
  - Do not ground the capacitor to a ground pattern through which a high current flows.
  - Do not fetch signals from the oscillator.
- 2.** The subclock oscillator is designed as a low-amplitude circuit for reducing power consumption, and is more prone to malfunction due to noise than the main clock oscillator. Particular care is therefore required with the wiring method when the subclock is used.
- 3.** For the resonator selection and oscillator constant, customers are requested to either evaluate the oscillation themselves or apply to the resonator manufacturer for evaluation.

## 35.4.3 PLL characteristics

(TA = -40 to +85°C, BV<sub>DD</sub> ≤ V<sub>DD</sub> = EV<sub>DD</sub> = AV<sub>REF0</sub> = AV<sub>REF1</sub>, V<sub>SS</sub> = EV<sub>SS</sub> = BV<sub>SS</sub> = AV<sub>SS</sub> = 0 V)

Parameter	Symbol	Conditions	MIN.	TYP.	MAX.	Unit	
<R> Input frequency	f <sub>x</sub>	Clock mode 1, CKC.CKDIV0 bit = 0	<b>Note 1</b>	3.0		5	MHz
<R>			<b>Note 2</b>	6.0		10	MHz
<R>		Clock mode 1, CKC.CKDIV0 bit = 1	<b>Note 1</b>	3.0		4	MHz
<R>			<b>Note 2</b>	6.0		8	MHz
<R> Output frequency	f <sub>xx</sub>	Clock mode 1, CKC.CKDIV0 bit = 0	<b>Note 1</b>	12		20	MHz
<R>			<b>Note 2</b>	12		20	MHz
<R>		Clock mode 1, CKC.CKDIV0 bit = 1	<b>Note 1</b>	24		32	MHz
<R>			<b>Note 2</b>	24		32	MHz
Lock time	t <sub>PLL</sub>	After V <sub>DD</sub> reaches 2.85 V (MIN.)			800	μs	

<R> **Notes** 1. PLLI0 bit of option byte 0000007BH = 0

&lt;R&gt; 2. PLLI0 bit of option byte 0000007BH = 1

**Remark** See CHAPTER 6 CLOCK GENERATION FUNCTION for details of clock mode 1.

## 35.4.4 SSCG characteristics

(TA = -40 to +85°C, BV<sub>DD</sub> ≤ V<sub>DD</sub> = EV<sub>DD</sub> = AV<sub>REF0</sub> = AV<sub>REF1</sub>, V<sub>SS</sub> = EV<sub>SS</sub> = BV<sub>SS</sub> = AV<sub>SS</sub> = 0 V)

Parameter	Symbol	Conditions	MIN.	TYP.	MAX.	Unit	
<R> Input frequency	f <sub>x</sub>	Clock mode 2, 3, CKC.CKDIV0 bit = 1	<b>Note 1</b>	3.66		4	MHz
<R>			<b>Note 2</b>	7.32		8	MHz
<R>		Clock mode 4, CKC.CKDIV0 bit = 1	<b>Note 1</b>	5.22		6	MHz
<R> Output frequency	f <sub>xx</sub>	Clock mode 2, CKC.CKDIV0 bit = 1	<b>Note 1</b>	43.92		48	MHz
<R>			<b>Note 2</b>	43.92		48	MHz
<R>		Clock mode , CKC.CKDIV0 bit = 1, SFC0 register = 2AH	<b>Note 1</b>	29.28		32	MHz
<R>			<b>Note 2</b>	29.28		32	MHz
<R>		Clock mode 3, CKC.CKDIV0 bit = 1, SFC0 register = 34H	<b>Note 1</b>	43.92		48	MHz
<R>			<b>Note 2</b>	43.92		48	MHz
<R>	Clock mode 4, CKC.CKDIV0 bit = 1	<b>Note 1</b>	41.76		48	MHz	
Lock time	t <sub>SSCG</sub>	After V <sub>DD</sub> reaches 2.85 V (MIN.)			1000	μs	

<R> **Notes** 1. PLLI0 bit of option byte 0000007BH = 0

&lt;R&gt; 2. PLLI0 bit of option byte 0000007BH = 1

**Remark** See CHAPTER 6 CLOCK GENERATION FUNCTION for details of clock modes 2 to 4.

## 35.4.5 Internal oscillator characteristics

(TA = -40 to +85°C, BV<sub>DD</sub> ≤ V<sub>DD</sub> = EV<sub>DD</sub> = AV<sub>REF0</sub> = AV<sub>REF1</sub>, V<sub>SS</sub> = EV<sub>SS</sub> = BV<sub>SS</sub> = AV<sub>SS</sub> = 0 V)

Parameter	Symbol	Conditions	MIN.	TYP.	MAX.	Unit
Output frequency	f <sub>R</sub>		100	220	400	kHz



### 35.5 Regulator Characteristics

( $T_A = -40$  to  $+85^\circ\text{C}$ ,  $BV_{DD} \leq V_{DD} = EV_{DD} = AV_{REF0} = AV_{REF1}$ ,  $V_{SS} = EV_{SS} = BV_{SS} = AV_{SS} = 0\text{ V}$ )

Parameter	Symbol	Conditions	MIN.	TYP.	MAX.	Unit
Input voltage	$V_{DD}$	$f_{XX} = 48\text{ MHz (MAX.)}$	2.85		3.6	V
Output voltage	$V_{RO}$		2.3	2.5	2.7	V
Regulator output stabilization time	$t_{REG}$	After $V_{DD}$ reaches 2.85 V (MIN.), Stabilization capacitance $C = 4.7\ \mu\text{F}$ connected to REGC pin			1	ms

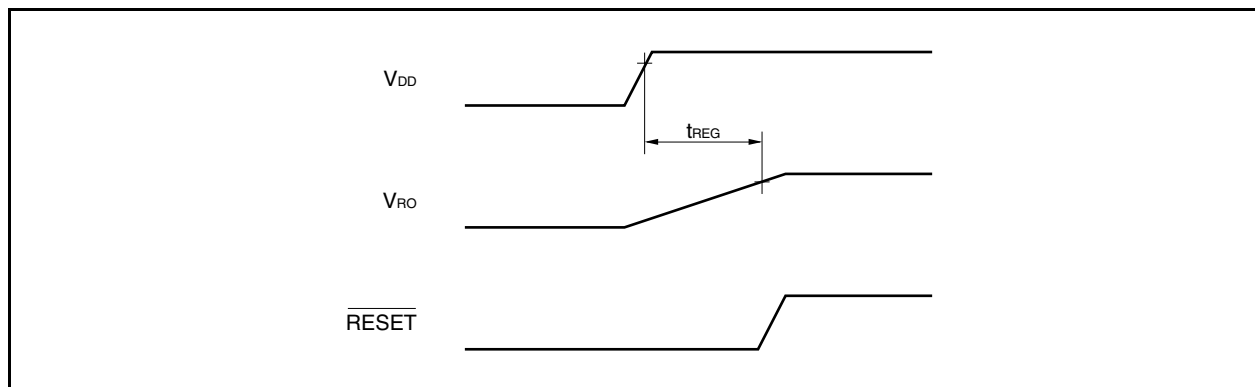

## 35.6 DC Characteristics

## 35.6.1 I/O level

( $T_A = -40$  to  $+85^\circ\text{C}$ ,  $BV_{DD} \leq V_{DD} = EV_{DD} = AV_{REF0} = AV_{REF1}$ ,  $V_{SS} = EV_{SS} = BV_{SS} = AV_{SS} = 0\text{ V}$ )

Parameter	Symbol	Conditions	MIN.	TYP.	MAX.	Unit
Input voltage, high	$V_{IH1}$	$\overline{\text{RESET}}$ , FLMD0	$0.8EV_{DD}$		$EV_{DD}$	V
	$V_{IH2}$	<b>Note 1</b>	$0.8EV_{DD}$		5.5	V
	$V_{IH3}$	<b>Note 2</b>	$0.7EV_{DD}$		5.5	V
	$V_{IH4}$	PCM0 to PCM5, PCS0 to PCS7, PCT0 to PCT7, PDH0 to PDH7, PDL0 to PDL15	$0.7BV_{DD}$		$BV_{DD}$	V
	$V_{IL5}$	<b>Note 3</b>	$0.8BV_{DD}$		$BV_{DD}$	V
	$V_{IH6}$	P70 to P715	$0.7AV_{REF0}$		$AV_{REF0}$	V
	$V_{IH7}$	P10, P11	$0.7AV_{REF1}$		$AV_{REF1}$	V
Input voltage, low	$V_{IL1}$	$\overline{\text{RESET}}$ , FLMD0	$EV_{SS}$		$0.2EV_{DD}$	V
	$V_{IL2}$	<b>Note 1</b>	$EV_{SS}$		$0.2EV_{DD}$	V
	$V_{IL3}$	<b>Note 2</b>	$EV_{SS}$		$0.3EV_{DD}$	V
	$V_{IL4}$	PCM0 to PCM5, PCS0 to PCS7, PCT0 to PCT7, PDH0 to PDH7, PDL0 to PDL15	$BV_{SS}$		$0.3BV_{DD}$	V
	$V_{IL5}$	<b>Note 3</b>	$BV_{SS}$		$0.2BV_{DD}$	V
	$V_{IL6}$	P70 to P715	$AV_{SS}$		$0.3AV_{REF0}$	V
	$V_{IL7}$	P10, P11	$AV_{SS}$		$0.3AV_{REF1}$	V
Input leakage current, high	$I_{LIH}$	P70 to P715	$V_I = V_{DD} = EV_{DD} = BV_{DD} = AV_{REF0} = AV_{REF1}$		2	$\mu\text{A}$
		Other		5	$\mu\text{A}$	
Input leakage current, low	$I_{LIL}$	P70 to P715	$V_I = 0\text{ V}$		-2	$\mu\text{A}$
		Other		-5	$\mu\text{A}$	
Output leakage current, high	$I_{LOH}$	P70 to P715	$V_O = V_{DD} = EV_{DD} = BV_{DD} = AV_{REF0} = AV_{REF1}$		2	$\mu\text{A}$
		Other		5	$\mu\text{A}$	
Output leakage current, low	$I_{LOL}$	P70 to P715	$V_O = 0\text{ V}$		-2	$\mu\text{A}$
		Other		-5	$\mu\text{A}$	

**Notes** 1. V850E/SJ3-H: P02 to P06, P30 to P37, P42, P50 to P55, P60 to P66, P69 to P613, P80, P81, P92 to P915

V850E/SK3-H: P02 to P06, P30 to P37, P310 to P312, P42 to P45, P50 to P57, P60 to P66, P69 to P613, P80, P81, P84, P85, P92 to P915, P150 to P153

2. V850E/SJ3-H: P00, P01, P38, P39, P40, P41, P67, P68, P614, P615, P90, P91

V850E/SK3-H: P00, P01, P20, P21, P38, P39, P40, P41, P67, P68, P614, P615, P82, P83, P90, P91

3. V850E/SJ3-H: PCD0 to PCD3

V850E/SK3-H: P130 to P133, P140 to P145, PCD0 to PCD3

**Remark** Unless specified otherwise, the characteristics of alternate-function pins are the same as those of port pins.

( $T_A = -40$  to  $+85^\circ\text{C}$ ,  $BV_{DD} \leq V_{DD} = EV_{DD} = AV_{REF0} = AV_{REF1}$ ,  $V_{SS} = EV_{SS} = BV_{SS} = AV_{SS} = 0\text{ V}$ )

Parameter	Symbol	Conditions		MIN.	TYP.	MAX.	Unit	
Output voltage, high	V <sub>OH1</sub>	<b>Note 1</b>	Per pin I <sub>OH</sub> = -1.0 mA	Total of all pins -20 mA	EV <sub>DD</sub> - 1.0		EV <sub>DD</sub>	V
			Per pin I <sub>OH</sub> = -100 $\mu\text{A}$	Total of all pins -6.0 mA	EV <sub>DD</sub> - 0.5		EV <sub>DD</sub>	V
	V <sub>OH2</sub>	<b>Note 2</b>	Per pin I <sub>OH</sub> = -1.0 mA	Total of all pins -20 mA	BV <sub>DD</sub> - 1.0		BV <sub>DD</sub>	V
			Per pin I <sub>OH</sub> = -100 $\mu\text{A}$	Total of all pins -5.0 mA	BV <sub>DD</sub> - 0.5		BV <sub>DD</sub>	V
	V <sub>OH3</sub>	P70 to P715	Per pin I <sub>OH</sub> = -0.4 mA	Total of all pins -6.4 mA	AV <sub>REF0</sub> - 1.0		AV <sub>REF0</sub>	V
			Per pin I <sub>OH</sub> = -100 $\mu\text{A}$	Total of all pins -1.6 mA	AV <sub>REF0</sub> - 0.5		AV <sub>REF0</sub>	V
	V <sub>OH4</sub>	P10, P11	Per pin I <sub>OH</sub> = -0.4 mA	Total of all pins -0.8 mA	AV <sub>REF1</sub> - 1.0		AV <sub>REF1</sub>	V
			Per pin I <sub>OH</sub> = -100 $\mu\text{A}$	Total of all pins -0.2 mA	AV <sub>REF1</sub> - 0.5		AV <sub>REF1</sub>	V
Output voltage, low	V <sub>OL1</sub>	<b>Note 3</b>	Per pin I <sub>OL</sub> = 1.0 mA	Total of all pins 20 mA	0		0.4	V
	V <sub>OL2</sub>	<b>Note 4</b>	Per pin I <sub>OL</sub> = 3.0 mA		0		0.4	V
	V <sub>OL3</sub>	<b>Note 5</b>	Per pin I <sub>OL</sub> = 1.0 mA	Total of all pins 20 mA	0		0.4	V
	V <sub>OL4</sub>	P10, P11, P70 to P715	Per pin I <sub>OL</sub> = 0.4 mA	Total of all pins 7.2 mA	0		0.4	V
Software pull-down resistor	R <sub>1</sub>	P05	V <sub>I</sub> = V <sub>DD</sub>		10	20	100	k $\Omega$

- Notes**
- V850E/SJ3-H: P00 to P06, P30 to P39, P40 to P42, P50 to P55, P60 to P615, P80, P81, P90 to P915  
V850E/SK3-H: P00 to P06, P20, P21, P30 to P312, P40 to P45, P50 to P57, P60 to P615, P80 to P85, P90 to P915, P150 to P153
  - V850E/SJ3-H: PCD0 to PCD3, PCM0 to PCM5, PCS0 to PCS7, PCT0 to PCT7, PDL0 to PDL15, PDH0 to PDH7  
V850E/SK3-H: P130 to P133, P140 to P145, PCD0 to PCD3, PCM0 to PCM5, PCS0 to PCS7, PCT0 to PCT7, PDL0 to PDL15, PDH0 to PDH7
  - V850E/SJ3-H: P00 to P06, P30 to P37, P42, P50 to P55, P60 to P615, P80, P81, P92 to P915  
V850E/SK3-H: P02 to P06, P30 to P37, P310 to P312, P42 to P45, P50 to P57, P60 to P66, P69 to P613, P80, P81, P84, P85, P92 to P915, P150 to P153
  - V850E/SJ3-H: P38, P39, P40, P41, P90, P91  
V850E/SK3-H: P00, P01, P20, P21, P38, P39, P40, P41, P67, P68, P614, P615, P82, P83, P90, P91
  - V850E/SJ3-H: PCD0 to PCD3, PCM0 to PCM5, PCS0 to PCS7, PCT0 to PCT7, PDL0 to PDL15, PDH0 to PDH7  
V850E/SK3-H: P130 to P133, P140 to P145, PCD0 to PCD3, PCM0 to PCM5, PCS0 to PCS7, PCT0 to PCT7, PDL0 to PDL15, PDH0 to PDH7

- Remarks**
- Unless specified otherwise, the characteristics of alternate-function pins are the same as those of port pins.
  - When the I<sub>OH</sub> and I<sub>OL</sub> conditions are not satisfied for a pin but the total value of all pins is satisfied, only that pin does not satisfy the DC characteristics.

## 35.6.2 Supply current

(T<sub>A</sub> = -40 to +85°C, BV<sub>DD</sub> ≤ V<sub>DD</sub> = EV<sub>DD</sub> = AV<sub>REF0</sub> = AV<sub>REF1</sub>, V<sub>SS</sub> = EV<sub>SS</sub> = BV<sub>SS</sub> = AV<sub>SS</sub> = 0 V)

Parameter	Symbol	Conditions		MIN.	TYP.	MAX.	Unit
<R> Supply current <sup>Note</sup>	I <sub>DD1</sub>	Normal operation	f <sub>xx</sub> = 48 MHz (clock mode 3, SFC0 register = 34H) peripheral function operating		62	80	mA
<R>	I <sub>DD2</sub>	HALT mode	f <sub>xx</sub> = 48 MHz (clock mode 3, SFC0 register = 34H) peripheral function operating		41	53	mA
<R>	I <sub>DD3</sub>	IDLE1 mode	f <sub>xx</sub> = 5 MHz (f <sub>x</sub> = 5 MHz), PLL off		1.45	2.4	mA
<R>	I <sub>DD4</sub>	IDLE2 mode	f <sub>xx</sub> = 5 MHz (f <sub>x</sub> = 5 MHz), PLL off		0.4	0.8	mA
<R>	I <sub>DD5</sub>	Subclock operating mode	f <sub>XT</sub> = 32.768 kHz, main clock, internal oscillator stopped		110	700	μA
<R>	I <sub>DD6</sub>	Sub-IDLE mode	f <sub>XT</sub> = 32.768 kHz, main clock, internal oscillator stopped		12	150	μA
<R>	I <sub>DD7</sub>	STOP mode	Subclock stopped, internal oscillator stopped		9	98	μA
<R>			Subclock operating, internal oscillator stopped		12	108	μA
<R>			Subclock stopped, internal oscillator operating		14	108	μA
<R>	I <sub>DD8</sub>	Flash memory programming mode	f <sub>xx</sub> = 48 MHz (f <sub>x</sub> = 6 MHz)		62	80	mA

**Notes** Total of V<sub>DD</sub>, EV<sub>DD</sub>, and BV<sub>DD</sub> currents. Current flowing through the output buffers, A/D converter, D/A converter, and on-chip pull-down resistor is not included.

### 35.7 Data Retention Characteristics

(1) In STOP mode

( $T_A = -40$  to  $+85^\circ\text{C}$ ,  $BV_{DD} \leq V_{DD} = EV_{DD} = AV_{REF0} = AV_{REF1}$ ,  $V_{SS} = EV_{SS} = BV_{SS} = AV_{SS} = 0\text{ V}$ )

Parameter	Symbol	Conditions	MIN.	TYP.	MAX.	Unit
Data retention voltage	$V_{DDDR}$	STOP mode (all functions stopped)	1.9		3.6	V
Data retention current	$I_{DDDR}$	STOP mode (all functions stopped), $V_{DDDR} = 2.0\text{ V}$		9	140	$\mu\text{A}$
Supply voltage rise time	$t_{RVD}$		200			$\mu\text{s}$
Supply voltage fall time	$t_{FVD}$		200			$\mu\text{s}$
Supply voltage retention time	$t_{HVD}$	After STOP mode setting	0			ms
STOP release signal input time	$t_{DREL}$	After $V_{DD}$ reaches 2.85 V (MIN.)	0			ms
Data retention input voltage, high	$V_{IHDR}$	$V_{DD} = EV_{DD} = BV_{DD} = V_{DDDR}$	$0.9V_{DDDR}$		$V_{DDDR}$	V
Data retention input voltage, low	$V_{ILDR}$	$V_{DD} = EV_{DD} = BV_{DD} = V_{DDDR}$	0		$0.1V_{DDDR}$	V

**Caution** Shifting to STOP mode and restoring from STOP mode must be performed within the rated operating range.

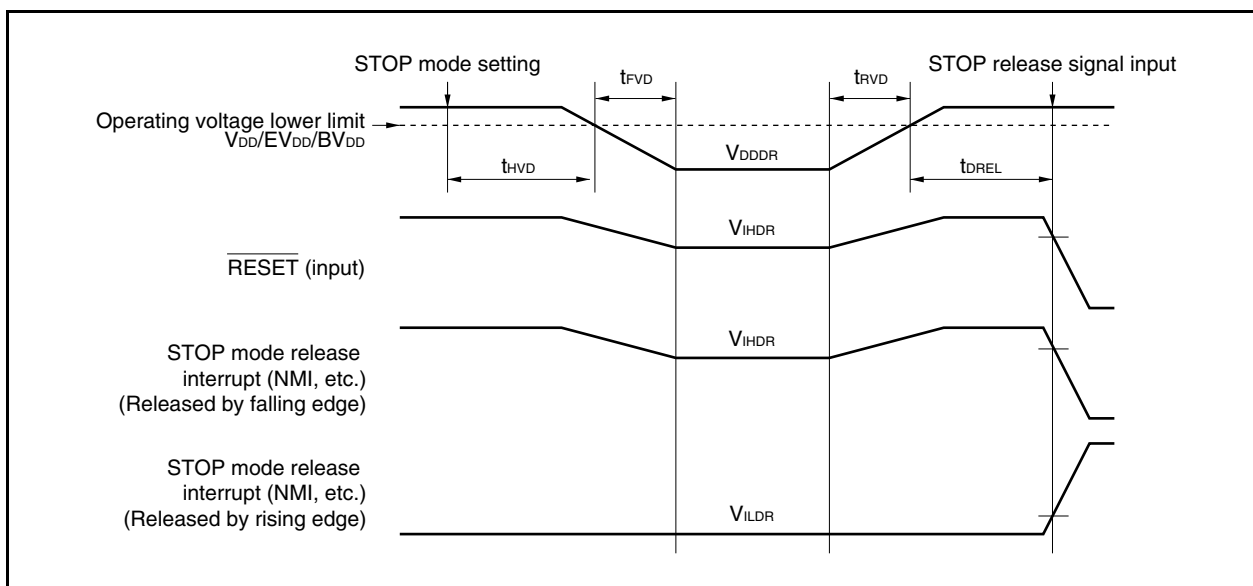

### 35.8 AC Characteristics

#### (1) AC Test Input Measurement Points ( $V_{DD}$ , $AV_{REF0}$ , $AV_{REF1}$ , $EV_{DD}$ , $BV_{DD}$ )

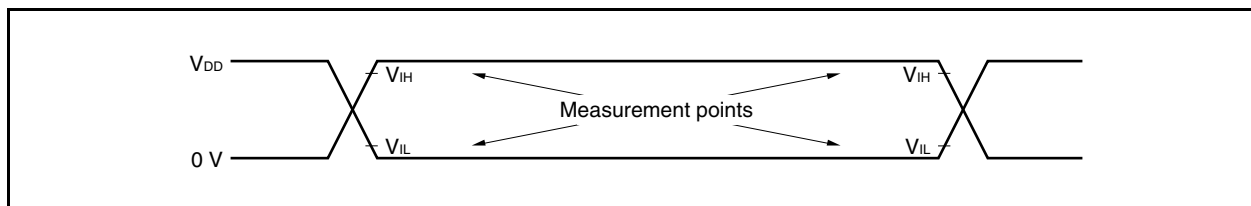

#### (2) AC Test Output Measurement Points

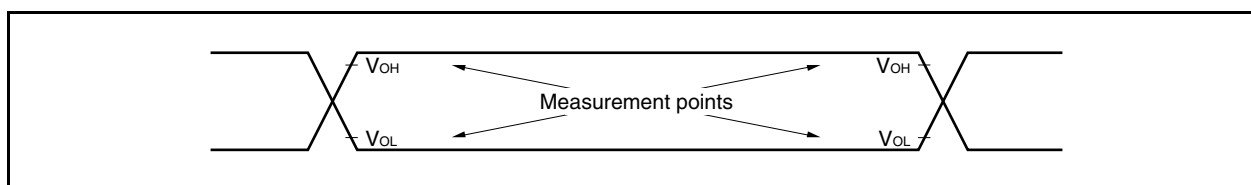

#### (3) Load Conditions

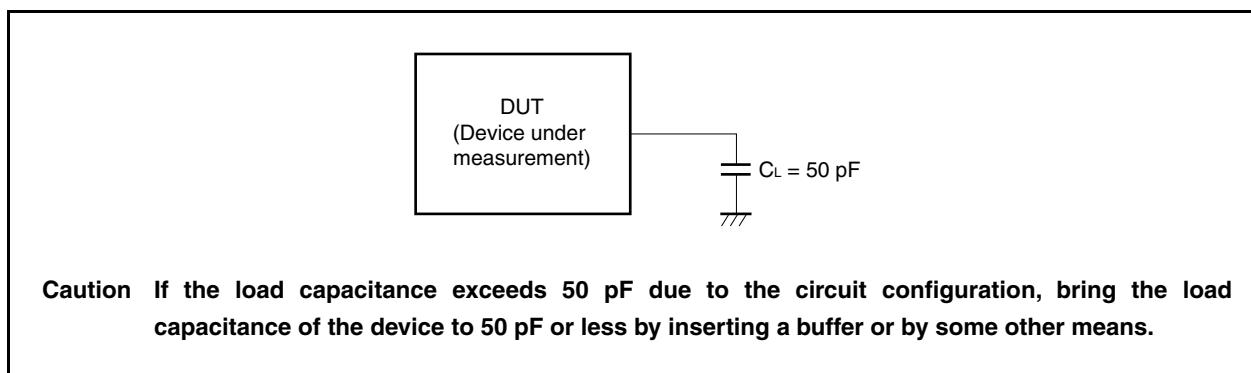

35.8.1 CLKOUT output timing

( $T_A = -40$  to  $+85^\circ\text{C}$ ,  $BV_{DD} \leq V_{DD} = EV_{DD} = AV_{REF0} = AV_{REF1}$ ,  $V_{SS} = EV_{SS} = BV_{SS} = AV_{SS} = 0\text{ V}$ )

Parameter	Symbol	Conditions	MIN.	MAX.	Unit
Output cycle	$t_{CYK}$	<1>	20.83 ns	31.25 $\mu\text{s}$	
High-level width	$t_{WKH}$	<2>	$t_{CYK}/2 - 6$		ns
Low-level width	$t_{WKL}$	<3>	$t_{CYK}/2 - 6$		ns
Rise time	$t_{KR}$	<4>		6	ns
Fall time	$t_{KF}$	<5>		6	ns

Clock Timing

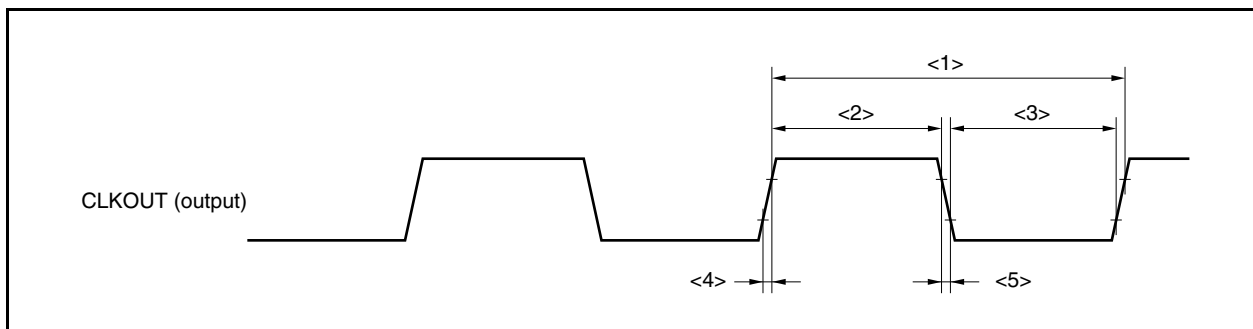

## 35.8.2 Bus timing

## (1) In multiplexed bus mode

- Cautions**
1. When operating at  $f_{CPU} > 20$  MHz, be sure to insert address hold waits and address setup waits.
  2. When operating at  $f_{CPU} > 32$  MHz, be sure to insert at least one data wait.

## (a) Read/write cycle (CLKOUT asynchronous)

( $T_A = -40$  to  $+85^\circ\text{C}$ ,  $BV_{DD} \leq V_{DD} = EV_{DD} = AV_{REF0} = AV_{REF1}$ ,  $V_{SS} = EV_{SS} = BV_{SS} = AV_{SS} = 0$  V,  $C_L = 50$  pF)

Parameter	Symbol	Conditions	MIN.	MAX.	Unit
Address setup time (to $ASTB\downarrow$ )	$t_{SAST}$	<6>	$(0.5 + t_{ASW})T - 20$		ns
Address hold time (from $ASTB\downarrow$ )	$t_{HSTA}$	<7>	$(0.5 + t_{AHW})T - 15$		ns
Delay time from $\overline{RD}\downarrow$ to address float	$t_{FRDA}$	<8>		16	ns
Data input setup time from address	$t_{SAID}$	<9>		$(2 + n + t_{ASW} + t_{AHW})T - 35$	ns
Data input setup time from $\overline{RD}\downarrow$	$t_{SRID}$	<10>		$(1 + n)T - 25$	ns
Delay time from $ASTB\downarrow$ to $\overline{RD}$ , $\overline{WRm}\downarrow$	$t_{DSTRDWR}$	<11>	$(0.5 + t_{AHW})T - 15$		ns
Data input hold time (from $\overline{RD}\uparrow$ )	$t_{HRDID}$	<12>	0		ns
Address output time from $\overline{RD}\uparrow$	$t_{DRDA}$	<13>	$(1 + i)T - 15$		ns
Delay time from $\overline{RD}$ , $\overline{WRm}\uparrow$ to $ASTB\uparrow$	$t_{DRDWRST}$	<14>	$0.5T - 15$		ns
Delay time from $\overline{RD}\uparrow$ to $ASTB\downarrow$	$t_{DRDST}$	<15>	$(1.5 + i + t_{ASW})T - 15$		ns
$\overline{RD}$ , $\overline{WRm}$ low-level width	$t_{WRDWRL}$	<16>	$(1 + n)T - 15$		ns
$ASTB$ high-level width	$t_{WSTH}$	<17>	$(1 + i + t_{ASW})T - 15$		ns
Data output time from $\overline{WRm}\downarrow$	$t_{DWROD}$	<18>		15	ns
Data output setup time (to $\overline{WRm}\uparrow$ )	$t_{SODWR}$	<19>	$(1 + n)T - 20$		ns
Data output hold time (from $\overline{WRm}\uparrow$ )	$t_{HWROD}$	<20>	$T - 15$		ns
$\overline{WAIT}$ setup time (to address)	$t_{SAWT1}$	<21> $n \geq 1$		$(1.5 + t_{ASW} + t_{AHW})T - 35$	ns
	$t_{SAWT2}$	<22>		$(1.5 + n + t_{ASW} + t_{AHW})T - 35$	ns
$\overline{WAIT}$ hold time (from address)	$t_{HAWT1}$	<23> $n \geq 1$	$(0.5 + n + t_{ASW} + t_{AHW})T$		ns
	$t_{HAWT2}$	<24>	$(1.5 + n + t_{ASW} + t_{AHW})T$		ns
$\overline{WAIT}$ setup time (to $ASTB\downarrow$ )	$t_{SSTWT1}$	<25> $n \geq 1$		$(1 + t_{AHW})T - 25$	ns
	$t_{SSTWT2}$	<26>		$(1 + n + t_{AHW})T - 25$	ns
$\overline{WAIT}$ hold time (from $ASTB\downarrow$ )	$t_{HSTWT1}$	<27> $n \geq 1$	$(n + t_{AHW})T$		ns
	$t_{HSTWT2}$	<28>	$(1 + n + t_{AHW})T$		ns

**Remarks** 1.  $t_{ASW}$ : Number of address setup wait clocks

$t_{AHW}$ : Number of address hold wait clocks

2.  $T = 1/f_{CPU}$  ( $f_{CPU}$ : CPU operating clock frequency)

3.  $n$ : Number of wait clocks inserted in the bus cycle

The sampling timing changes when a programmable wait is inserted.

4.  $m = 0, 1$

5.  $i$ : Number of idle states inserted after a read cycle (0 or 1)

6. The values in the above specifications are values for when clocks with a 1:1 duty ratio are input from X1.



Read Cycle (CLKOUT Asynchronous): In Multiplexed Bus Mode

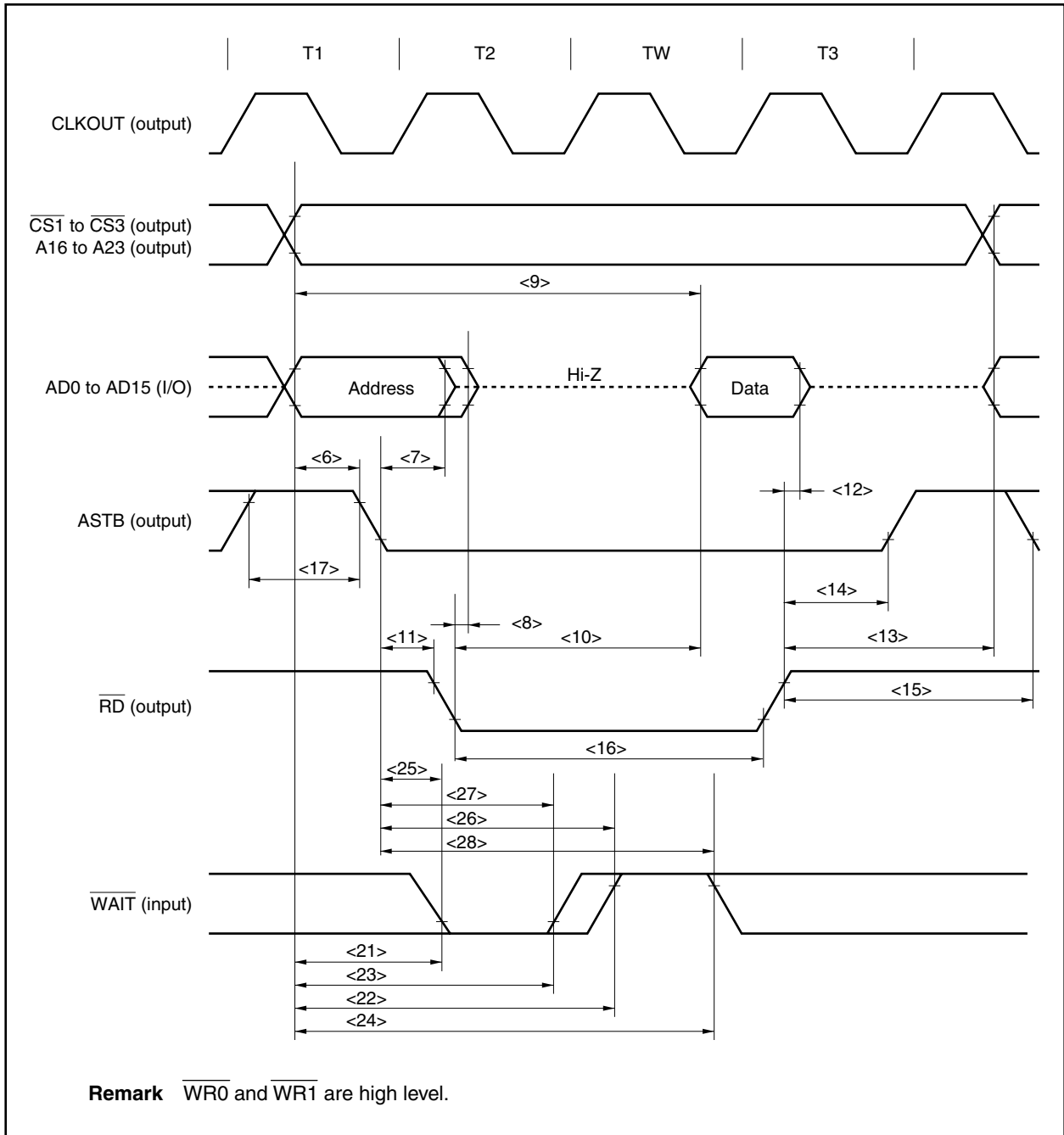

Write Cycle (CLKOUT Asynchronous): In Multiplexed Bus Mode

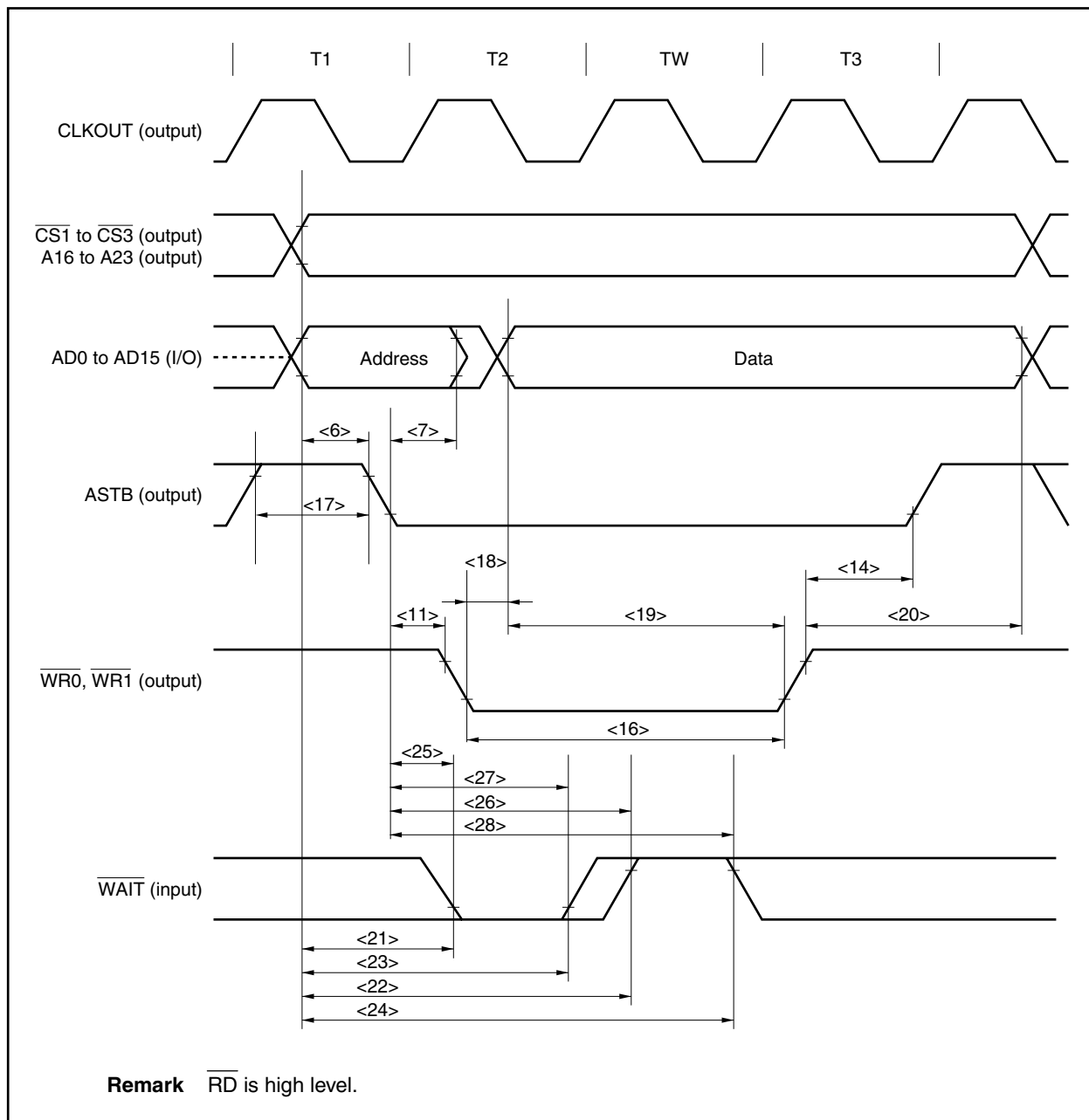

**(b) Read/write cycle (CLKOUT synchronous): In multiplexed bus mode**

( $T_A = -40$  to  $+85^\circ\text{C}$ ,  $BV_{DD} \leq V_{DD} = EV_{DD} = AV_{REF0} = AV_{REF1}$ ,  $V_{SS} = EV_{SS} = BV_{SS} = AV_{SS} = 0$  V,  $C_L = 50$  pF)

Parameter	Symbol	Conditions	MIN.	MAX.	Unit
Delay time from CLKOUT $\uparrow$ to address	$t_{DKA}$	<29>	0	25	ns
Delay time from CLKOUT $\uparrow$ to address float	$t_{FKA}$	<30>	0	19	ns
Delay time from CLKOUT $\downarrow$ to ASTB	$t_{DKST}$	<31>	-12	7	ns
Delay time from CLKOUT $\uparrow$ to $\overline{RD}$ , $\overline{WRm}$	$t_{DKRDWR}$	<32>	-5	14	ns
Data input setup time (to CLKOUT $\uparrow$ )	$t_{SIDK}$	<33>	15		ns
Data input hold time (from CLKOUT $\uparrow$ )	$t_{HKID}$	<34>	5		ns
Data output delay time from CLKOUT $\uparrow$	$t_{DKOD}$	<35>		19	ns
$\overline{WAIT}$ setup time (to CLKOUT $\downarrow$ )	$t_{SWTK}$	<36>	20		ns
$\overline{WAIT}$ hold time (from CLKOUT $\downarrow$ )	$t_{HKWT}$	<37>	5		ns

**Remarks 1.**  $m = 0, 1$

**2.** The values in the above specifications are values for when clocks with a 1:1 duty ratio are input from X1.

**Read Cycle (CLKOUT Synchronous): In Multiplexed Bus Mode**

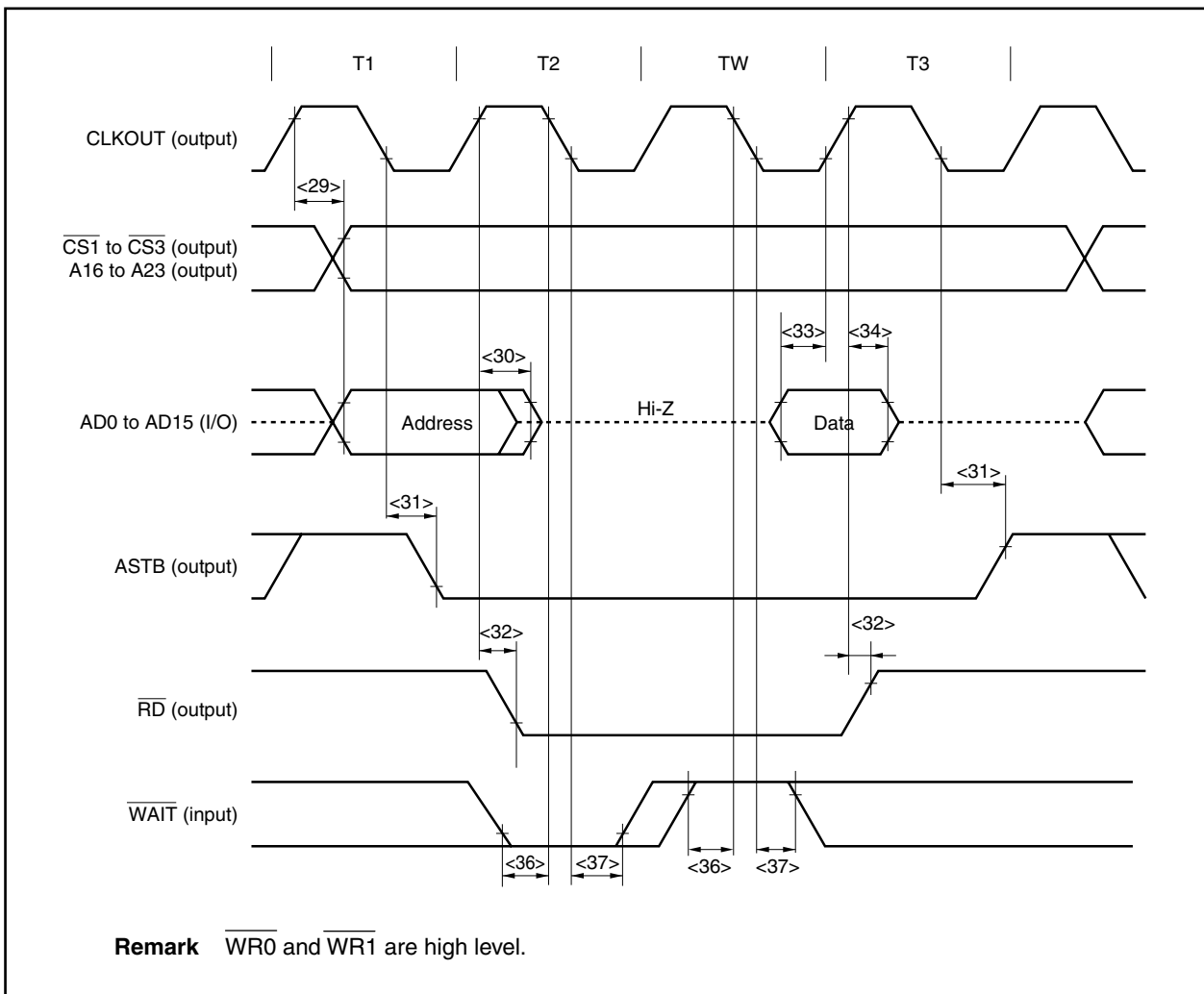

Write Cycle (CLKOUT Synchronous): In Multiplexed Bus Mode

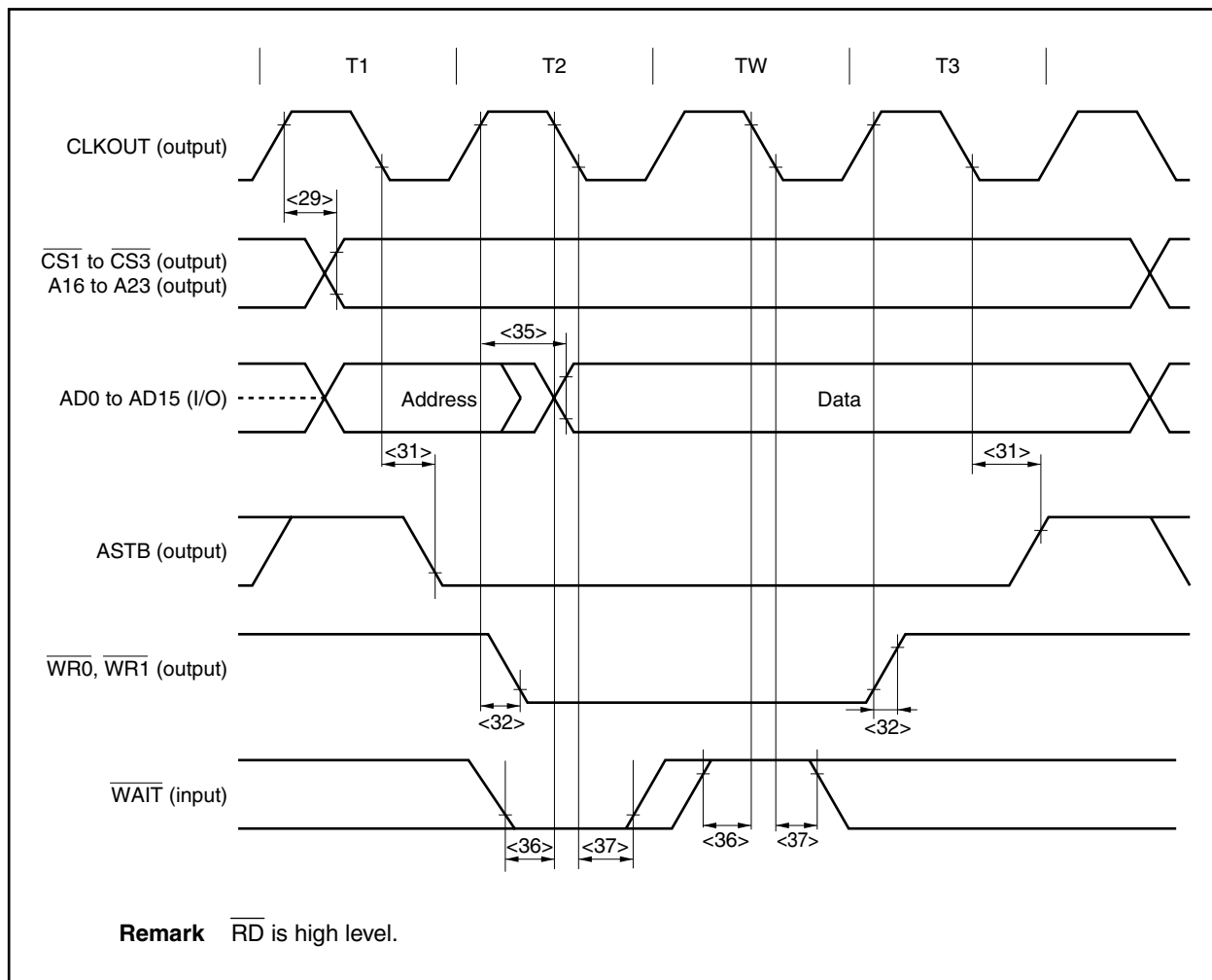

**(2) In separate bus mode**

- Cautions 1.** When operating at  $f_{CPU} > 20$  MHz, be sure to insert address hold waits and address setup waits.
- 2.** When operating at  $f_{CPU} > 20$  MHz, be sure to insert at least one data wait.

**(a) Read cycle (CLKOUT asynchronous): In separate bus mode**

( $T_A = -40$  to  $+85^\circ\text{C}$ ,  $BV_{DD} \leq V_{DD} = EV_{DD} = AV_{REF0} = AV_{REF1}$ ,  $V_{SS} = EV_{SS} = BV_{SS} = AV_{SS} = 0$  V,  $C_L = 50$  pF)

Parameter	Symbol	Conditions	MIN.	MAX.	Unit
Address setup time (to $\overline{RD}\downarrow$ )	$t_{SARD}$	<38>	$(0.5 + t_{ASW})T - 27$		ns
Address hold time (from $\overline{RD}\uparrow$ )	$t_{HARD}$	<39>	$iT - 3.5^{\text{Note}}$		ns
$\overline{RD}$ low-level width	$t_{WRDL}$	<40>	$(1.5 + n + t_{AHW})T - 10$		ns
Data setup time (to $\overline{RD}\uparrow$ )	$t_{SISD}$	<41>	23		ns
Data hold time (from $\overline{RD}\uparrow$ )	$t_{HISD}$	<42>	- 3.5		ns
Data setup time (to address)	$t_{SAID}$	<43>		$(2 + n + t_{ASW} + t_{AHW})T - 40$	ns
$\overline{WAIT}$ setup time (to $\overline{RD}\downarrow$ )	$t_{SRDWT1}$	<44>		$(0.5 + t_{AHW})T - 27$	ns
	$t_{SRDWT2}$	<45>		$(0.5 + n + t_{AHW})T - 27$	ns
$\overline{WAIT}$ hold time (from $\overline{RD}\downarrow$ )	$t_{HRDWT1}$	<46>	$(n - 0.5 + t_{AHW})T$		ns
	$t_{HRDWT2}$	<47>	$(n + 0.5 + t_{AHW})T$		ns
$\overline{WAIT}$ setup time (to address)	$t_{SAWT1}$	<48>		$(1 + t_{ASW} + t_{AHW})T - 45$	ns
	$t_{SAWT2}$	<49>		$(1 + n + t_{ASW} + t_{AHW})T - 45$	ns
$\overline{WAIT}$ hold time (from address)	$t_{HAWT1}$	<50>	$(n + t_{ASW} + t_{AHW})T$		ns
	$t_{HAWT2}$	<51>	$(1 + n + t_{ASW} + t_{AHW})T$		ns

**Note** The address may be changed during the low-level period of the  $\overline{RD}$  pin. To avoid the address change, insert an address wait.

**Remarks 1.**  $t_{ASW}$ : Number of address setup wait clocks

$t_{AHW}$ : Number of address hold wait clocks

**2.**  $T = 1/f_{CPU}$  ( $f_{CPU}$ : CPU operating clock frequency)

**3.**  $n$ : Number of wait clocks inserted in the bus cycle

The sampling timing changes when a programmable wait is inserted

**4.**  $i$ : Number of idle states inserted after a read cycle (0 or 1)

**5.** The values in the above specifications are values for when clocks with a 1:1 duty ratio are input from X1.

Read Cycle (CLKOUT Asynchronous): In Separate Bus Mode

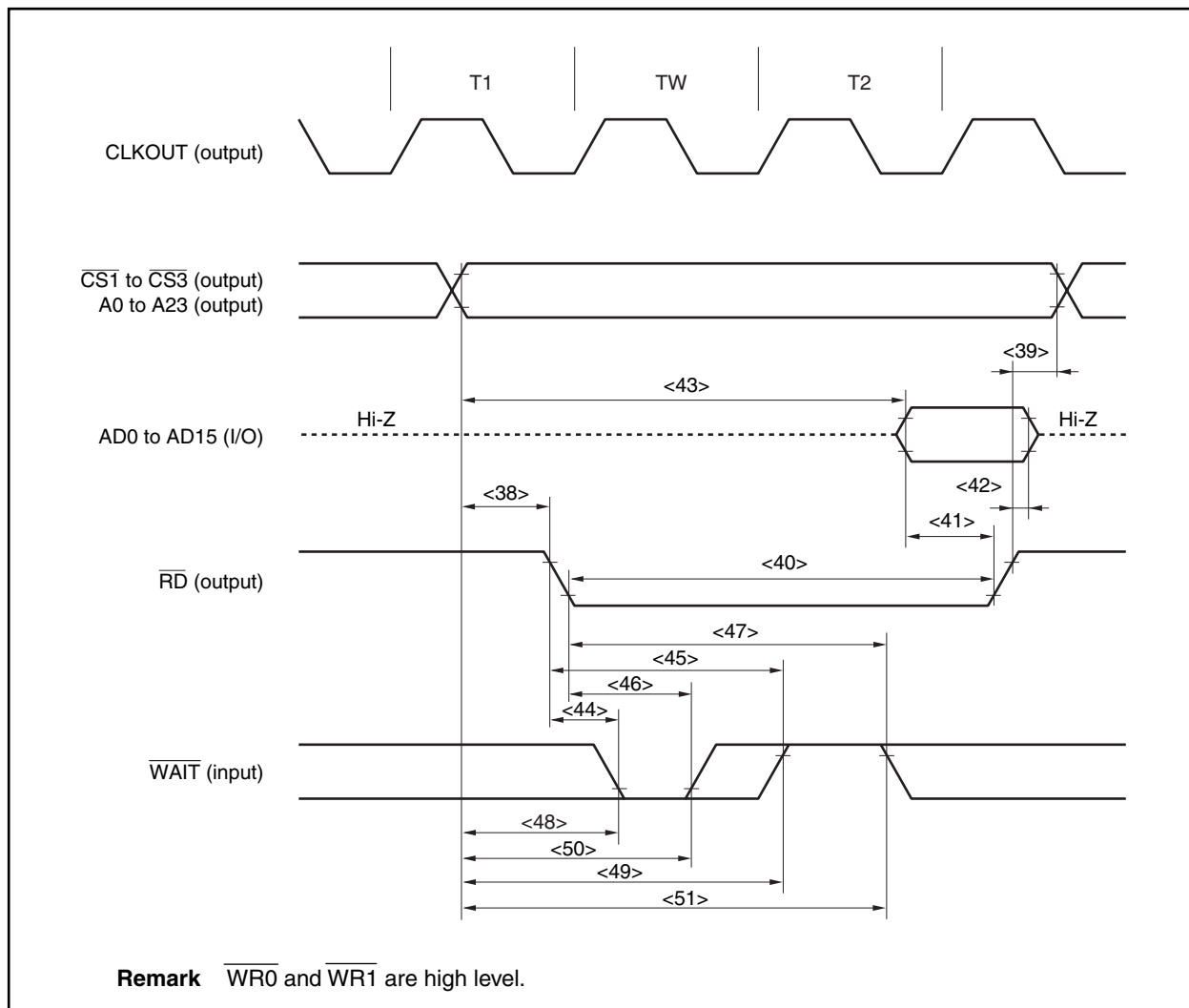

**(b) Write cycle (CLKOUT asynchronous): In separate bus mode**
**( $T_A = -40$  to  $+85^\circ\text{C}$ ,  $BV_{DD} \leq V_{DD} = EV_{DD} = AV_{REF0} = AV_{REF1}$ ,  $V_{SS} = EV_{SS} = BV_{SS} = AV_{SS} = 0\text{ V}$ ,  $C_L = 50\text{ pF}$ )**

Parameter	Symbol	Conditions	MIN.	MAX.	Unit
Address setup time (to $\overline{WRm}\downarrow$ )	$t_{SAWR}$	<52>	$(1 + t_{ASW} + t_{AHW})T - 27$		ns
Address hold time (from $\overline{WRm}\uparrow$ )	$t_{HAWR}$	<53>	$0.5T - 6$		ns
$\overline{WRm}$ low-level width	$t_{WWRL}$	<54>	$(0.5 + n)T - 10$		ns
Data output time from $\overline{WRm}\downarrow$	$t_{DOSDW}$	<55>	-5		ns
Data setup time (to $\overline{WRm}\uparrow$ )	$t_{SOSDW}$	<56>	$(0.5 + n)T - 20$		ns
Data hold time (from $\overline{WRm}\uparrow$ )	$t_{HOSDW}$	<57>	$0.5T - 7$		ns
Data setup time (to address)	$t_{SAOD}$	<58>	$(1 + t_{ASW} + t_{AHW})T - 25$		ns
$\overline{WAIT}$ setup time (to $\overline{WRm}\downarrow$ )	$t_{SWRWT1}$	<59>	25		ns
	$t_{SWRWT2}$	<60>		$nT - 25$	ns
$\overline{WAIT}$ hold time (from $\overline{WRm}\downarrow$ )	$t_{HWRWT1}$	<61>	0		ns
	$t_{HWRWT2}$	<62>	$nT$		ns
$\overline{WAIT}$ setup time (to address)	$t_{SAWT1}$	<63>		$(1 + t_{ASW} + t_{AHW})T - 45$	ns
	$t_{SAWT2}$	<64>		$(1 + n + t_{ASW} + t_{AHW})T - 45$	ns
$\overline{WAIT}$ hold time (from address)	$t_{HAWT1}$	<65>	$(n + t_{ASW} + t_{AHW})T$		ns
	$t_{HAWT2}$	<66>	$(1 + n + t_{ASW} + t_{AHW})T$		ns

**Remarks 1.**  $m = 0, 1$ 
**2.**  $t_{ASW}$ : Number of address setup wait clocks

 $t_{AHW}$ : Number of address hold wait clocks

**3.**  $T = 1/f_{CPU}$  ( $f_{CPU}$ : CPU operating clock frequency)

**4.**  $n$ : Number of wait clocks inserted in the bus cycle

The sampling timing changes when a programmable wait is inserted.

**5.** The values in the above specifications are values for when clocks with a 1:1 duty ratio are input from X1.

Write Cycle (CLKOUT Asynchronous): In Separate Bus Mode

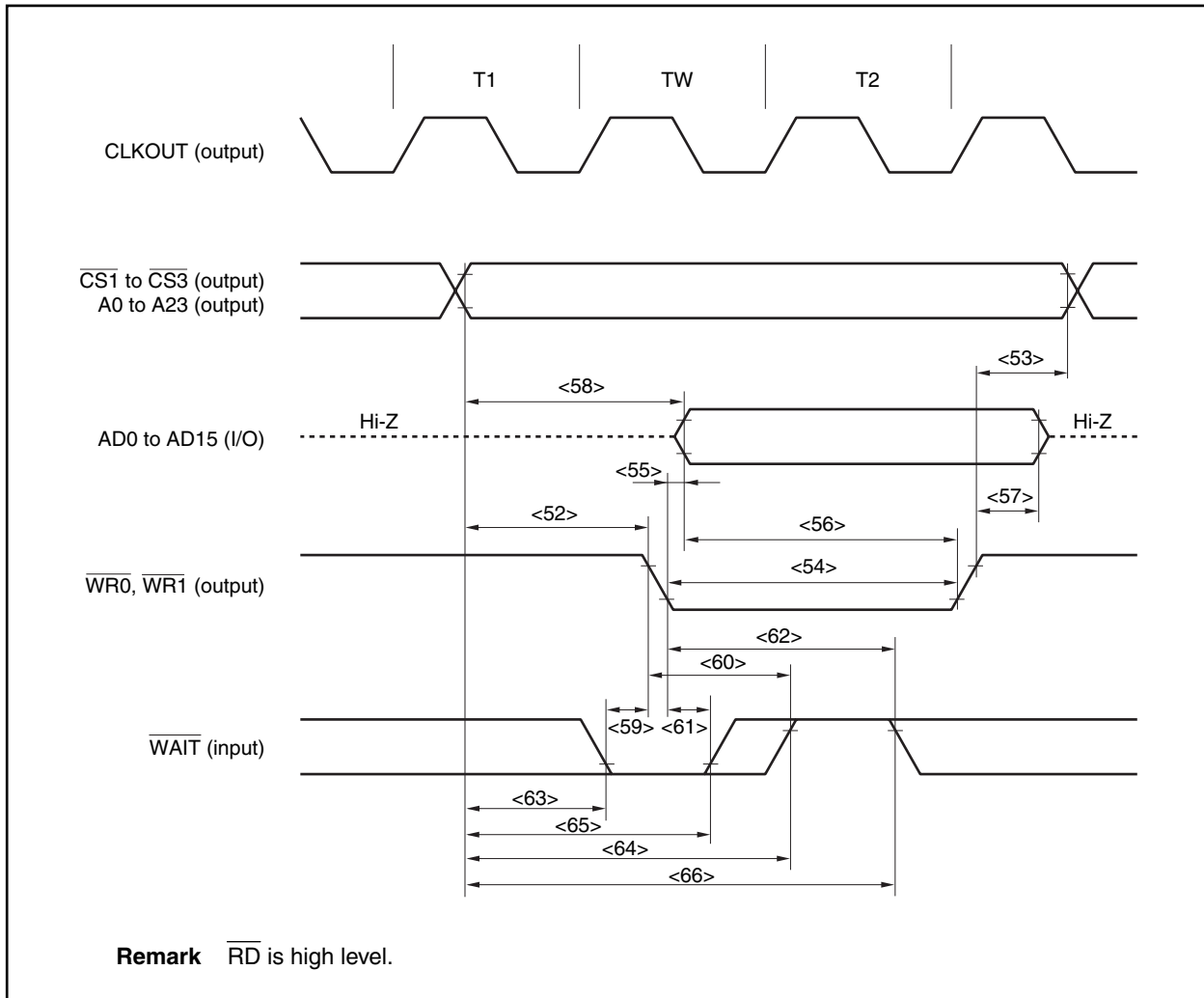



(c) Read cycle (CLKOUT synchronous): In separate bus mode

( $T_A = -40$  to  $+85^\circ\text{C}$ ,  $BV_{DD} \leq V_{DD} = EV_{DD} = AV_{REF0} = AV_{REF1}$ ,  $V_{SS} = EV_{SS} = BV_{SS} = AV_{SS} = 0$  V,  $C_L = 50$  pF)

Parameter	Symbol	Conditions	MIN.	MAX.	Unit
Delay time from CLKOUT $\uparrow$ to address, CS	$t_{DKSA}$	<67>	0	27	ns
Data input setup time (to CLKOUT $\uparrow$ )	$t_{SISDK}$	<68>	20		ns
Data input hold time (from CLKOUT $\uparrow$ )	$t_{HKISD}$	<69>	0		ns
Delay time from CLKOUT $\downarrow$ to $\overline{RD}$	$t_{DKSR}$	<70>	-2	12	ns
$\overline{WAIT}$ setup time (to CLKOUT $\uparrow$ )	$t_{SWTK}$	<71>	20		ns
$\overline{WAIT}$ hold time (from CLKOUT $\uparrow$ )	$t_{HKWT}$	<72>	0		ns

**Remark** The values in the above specifications are values for when clocks with a 1:1 duty ratio are input from X1.

Read Cycle (CLKOUT Synchronous, 1 Wait): In Separate Bus Mode

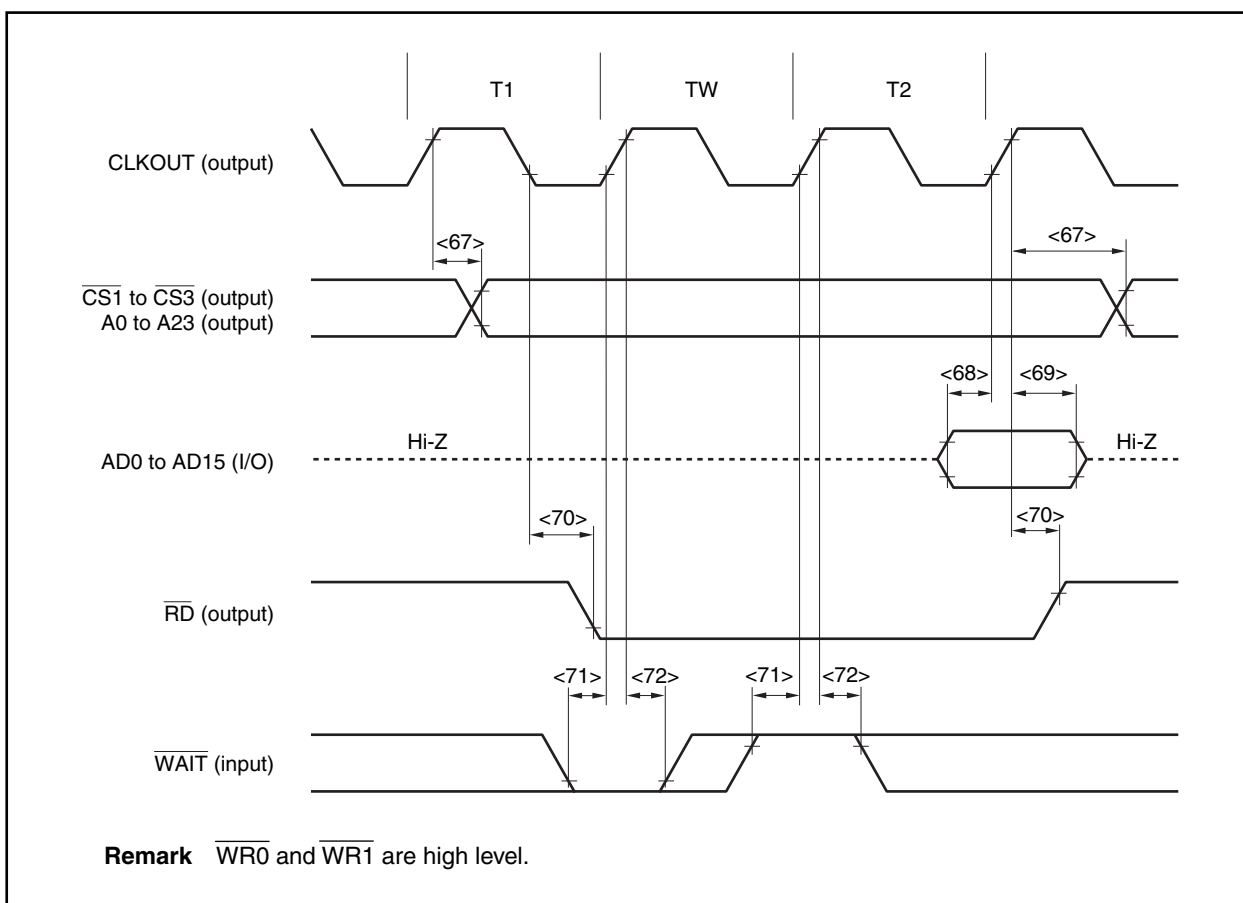

(d) Write cycle (CLKOUT synchronous): In separate bus mode

( $T_A = -40$  to  $+85^\circ\text{C}$ ,  $BV_{DD} \leq V_{DD} = EV_{DD} = AV_{REF0} = AV_{REF1}$ ,  $V_{SS} = EV_{SS} = BV_{SS} = AV_{SS} = 0$  V,  $C_L = 50$  pF)

Parameter	Symbol	Conditions	MIN.	MAX.	Unit
Delay time from CLKOUT $\uparrow$ to address, CS	$t_{DKSA}$	<73>	0	27	ns
Delay time from CLKOUT $\uparrow$ to data output	$t_{DKSD}$	<74>	0	18	ns
Delay time from CLKOUT $\uparrow\downarrow$ to $\overline{WR}_m$	$t_{DKSW}$	<75>	-2	12	ns
$\overline{WAIT}$ setup time (to CLKOUT $\uparrow$ )	$t_{SWTK}$	<76>	20		ns
$\overline{WAIT}$ hold time (from CLKOUT $\uparrow$ )	$t_{HKWT}$	<77>	0		ns

Remarks 1.  $m = 0, 1$

2. The values in the above specifications are values for when clocks with a 1:1 duty ratio are input from X1.

Write Cycle (CLKOUT Synchronous): In Separate Bus Mode

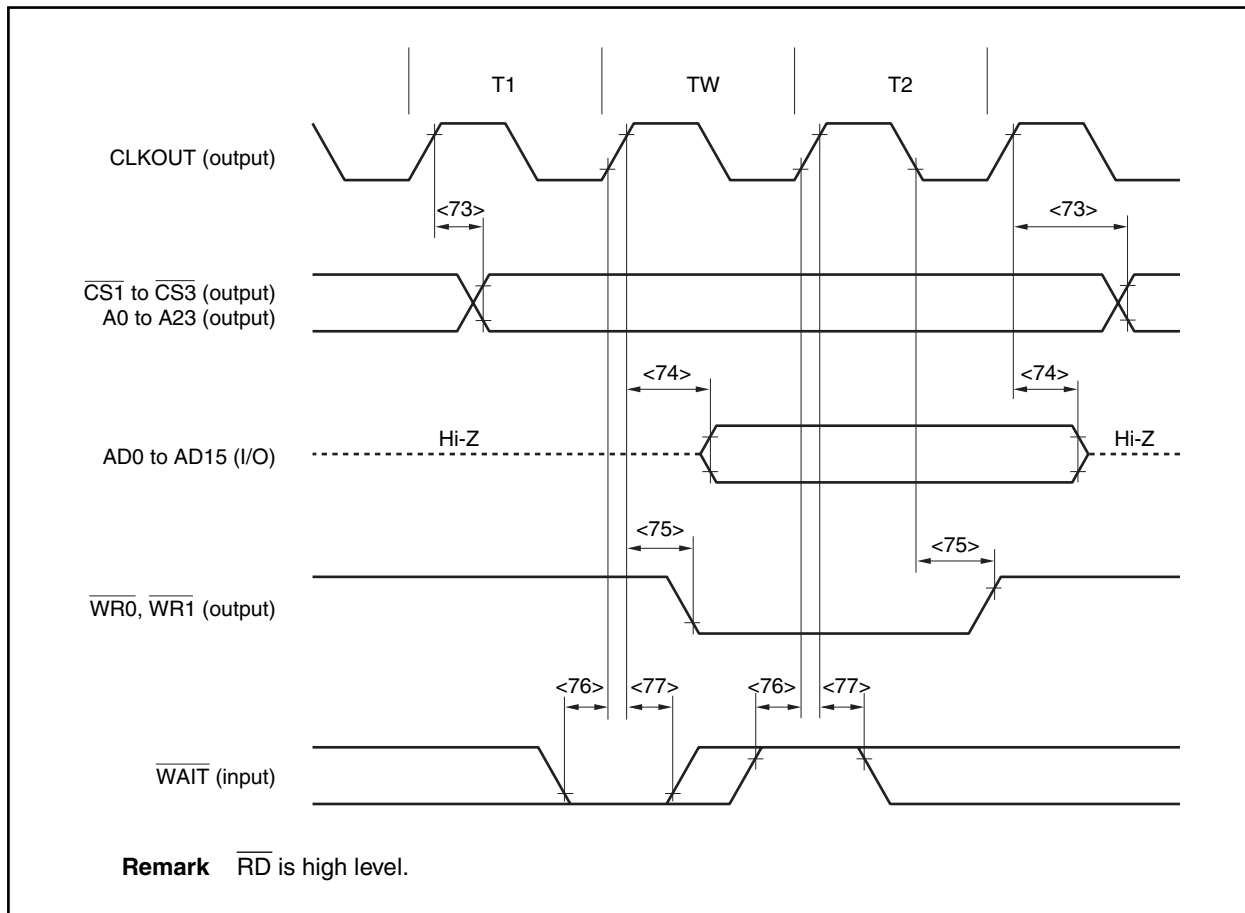

(3) Bus hold

(a) CLKOUT asynchronous

( $T_A = -40$  to  $+85^\circ\text{C}$ ,  $BV_{DD} \leq V_{DD} = EV_{DD} = AV_{REF0} = AV_{REF1}$ ,  $V_{SS} = EV_{SS} = BV_{SS} = AV_{SS} = 0\text{ V}$ ,  $C_L = 50\text{ pF}$ )

Parameter	Symbol	Conditions	MIN.	MAX.	Unit
$\overline{\text{HLDRQ}}$ high-level width	$t_{\text{WHQH}}$	<78>	$T + 10$		ns
$\overline{\text{HLDAK}}$ low-level width	$t_{\text{WHAL}}$	<79>	$T - 15$		ns
Delay time from $\overline{\text{HLDAK}}\uparrow$ to bus output	$t_{\text{DHAC}}$	<80>	-3		ns
Delay time from $\overline{\text{HLDRQ}}\downarrow$ to $\overline{\text{HLDAK}}\downarrow$	$t_{\text{DHQA1}}$	<81>		$(2n + 7.5)T + 26$	ns
Delay time from $\overline{\text{HLDRQ}}\uparrow$ to $\overline{\text{HLDAK}}\uparrow$	$t_{\text{DHQA2}}$	<82>	$0.5T$	$1.5T + 26$	ns

**Remarks 1.**  $T = 1/f_{\text{CPU}}$  ( $f_{\text{CPU}}$ : CPU operating clock frequency)

**2.** n: Number of wait clocks inserted in the bus cycle

The sampling timing changes when a programmable wait is inserted.

**3.** The values in the above specifications are values for when clocks with a 1:1 duty ratio are input from X1.

Bus Hold (CLKOUT Asynchronous)

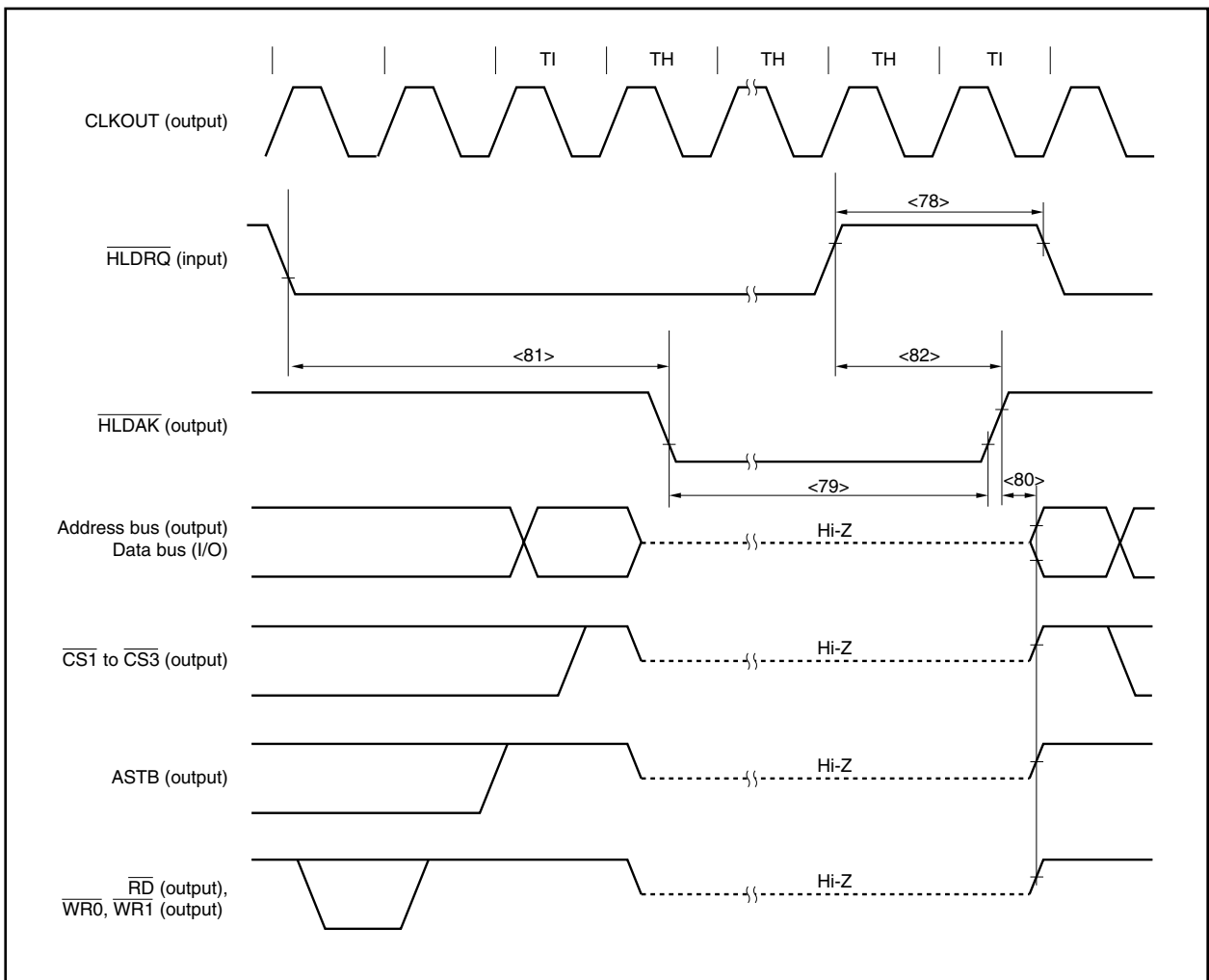

(b) CLKOUT synchronous

( $T_A = -40$  to  $+85^\circ\text{C}$ ,  $BV_{DD} \leq V_{DD} = EV_{DD} = AV_{REF0} = AV_{REF1}$ ,  $V_{SS} = EV_{SS} = BV_{SS} = AV_{SS} = 0$  V,  $C_L = 50$  pF)

Parameter	Symbol	Conditions	MIN.	MAX.	Unit
H $\overline{\text{LDRQ}}$ setup time (to CLKOUT $\downarrow$ )	$t_{\text{SHOQ}}$	<83>	20		ns
H $\overline{\text{LDRQ}}$ hold time (from CLKOUT $\downarrow$ )	$t_{\text{HKHQ}}$	<84>	5		ns
Delay time from CLKOUT $\uparrow$ to bus float	$t_{\text{DKF}}$	<85>		19	ns
Delay time from CLKOUT $\uparrow$ to H $\overline{\text{LDAK}}$	$t_{\text{DKHA}}$	<86>		19	ns

**Remark** The values in the above specifications are values for when clocks with a 1:1 duty ratio are input from X1.

Bus Hold (CLKOUT Synchronous)

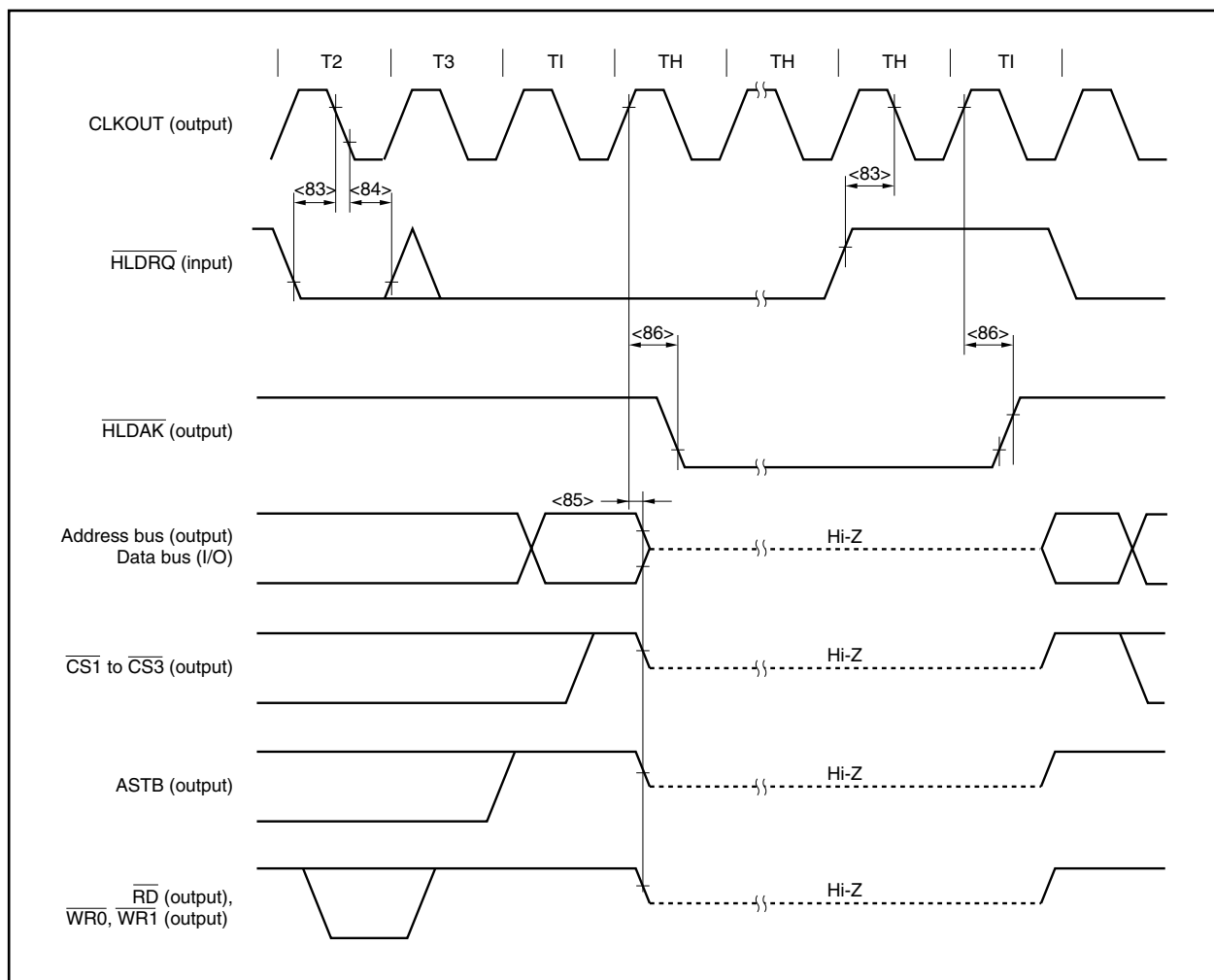

### 35.9 Basic Operation

#### (1) Power on/power off/reset timing

( $T_A = -40$  to  $+85^\circ\text{C}$ ,  $V_{SS} = AV_{SS} = BV_{SS} = EV_{SS} = 0\text{ V}$ ,  $C_L = 50\text{ pF}$ )

Parameter	Symbol	Conditions	MIN.	MAX.	Unit
$EV_{DD}\uparrow \rightarrow V_{DD}\uparrow$	$t_{REL}$ <87>		0		ns
$EV_{DD}\uparrow \rightarrow BV_{DD}\uparrow$	$t_{REB}$ <88>		0	$t_{REL}$	ns
$EV_{DD}\uparrow \rightarrow AV_{REF0}, AV_{REF1}\uparrow$	$t_{REA}$ <89>		0	$t_{REL}$	ns
$V_{DD}\uparrow \rightarrow \overline{RESET}\uparrow$	$t_{RER}$ <90>		500 + $t_{REG}^{Note}$		ns
$\overline{RESET}$ low-level width	$t_{WRSL}$ <91>	Analog noise elimination (during flash erase/ writing)	500		ns
		Analog noise elimination	500		ns
$\overline{RESET}\downarrow \rightarrow V_{DD}\downarrow$	$t_{FRE}$ <92>		500		ns
$V_{DD}\downarrow \rightarrow EV_{DD}\downarrow$	$t_{FEL}$ <93>		0		ns
$BV_{DD}\downarrow \rightarrow EV_{DD}\downarrow$	$t_{FEB}$ <94>		0	$t_{FEL}$	ns
$AV_{REF0}, AV_{REF1}\downarrow \rightarrow EV_{DD}\downarrow$	$t_{FEA}$ <95>		0	$t_{FEL}$	ns

**Note** Depends on the on-chip regulator characteristics.

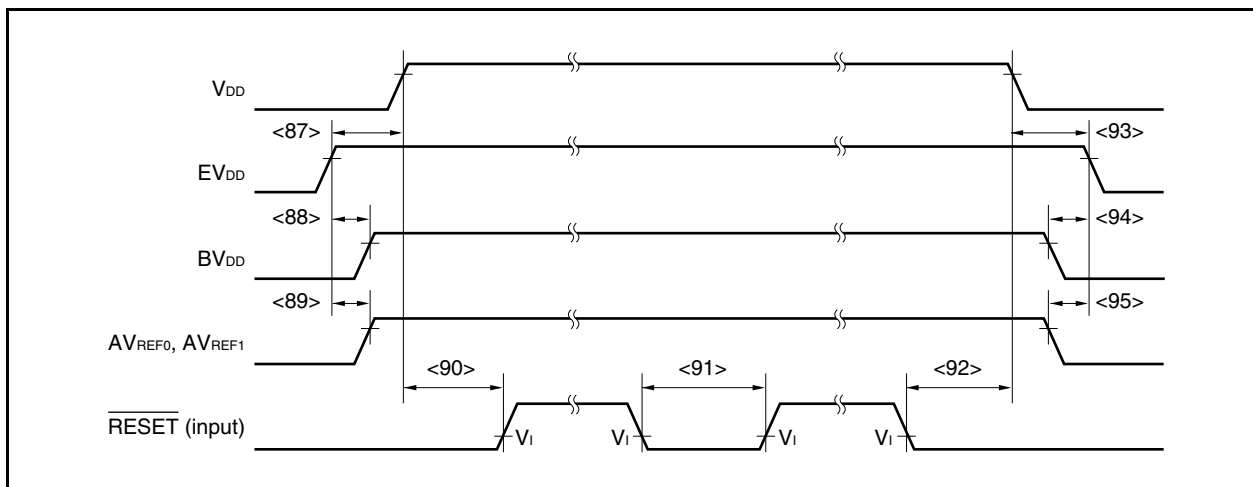

**(2) Interrupt, FLMD0 pin timing**
**( $T_A = -40$  to  $+85^\circ\text{C}$ ,  $BV_{DD} \leq V_{DD} = EV_{DD} = AV_{REF0} = AV_{REF1}$ ,  $V_{SS} = EV_{SS} = BV_{SS} = AV_{SS} = 0$  V,  $C_L = 50$  pF)**

Parameter	Symbol	Conditions	MIN.	MAX.	Unit
NMI high-level width	$t_{WNIH}$	Analog noise elimination	500		ns
NMI low-level width	$t_{WNIL}$	Analog noise elimination	500		ns
INTPn <sup>Note</sup> high-level width	$t_{WITH}$	$n = 0$ to 9 (Analog noise elimination)	500		ns
		$n = 3$ (Digital noise elimination)	$3T_{SMP} + 20$		ns
INTPn <sup>Note</sup> low-level width	$t_{WITL}$	$n = 0$ to 9 (Analog noise elimination)	500		ns
		$n = 3$ (Digital noise elimination)	$3T_{SMP} + 20$		ns
FLMD0 high-level width	$t_{WMDH}$		500		ns
FLMD0 low-level width	$t_{WMDL}$		500		ns

**Note** The  $\overline{DRST}$  pin has the same characteristics as the INTP2 pin.

**Remark**  $T_{SMP}$ : Noise elimination sampling clock cycle (specified by the NFC register)

**(3) Key return timing**
**( $T_A = -40$  to  $+85^\circ\text{C}$ ,  $BV_{DD} \leq V_{DD} = EV_{DD} = AV_{REF0} = AV_{REF1}$ ,  $V_{SS} = EV_{SS} = BV_{SS} = AV_{SS} = 0$  V,  $C_L = 50$  pF)**

Parameter	Symbol	Conditions	MIN.	MAX.	Unit
KRn high-level width	$t_{WKRH}$	Analog noise elimination	500		ns
KRn low-level width	$t_{WKRL}$	Analog noise elimination	500		ns

**Remark**  $n = 0$  to 7

**(4) Timer timing**
**( $T_A = -40$  to  $+85^\circ\text{C}$ ,  $BV_{DD} \leq V_{DD} = EV_{DD} = AV_{REF0} = AV_{REF1}$ ,  $V_{SS} = EV_{SS} = BV_{SS} = AV_{SS} = 0$  V,  $C_L = 50$  pF)**

Parameter	Symbol	Conditions	MIN.	MAX.	Unit
TIn high-level width	$t_{TIHn}$	$n = P00, P01, P10, P11, P20, P21, P30, P31, P40, P41, P50, P51, P60, P61, P70, P71, P80, P81, Q00$ to $Q03$	$2T + 20$		ns
TIn low-level width	$t_{TILn}$		$2T + 20$		ns
TEMCm0/TEMCm1 high-level width	$t_{TENChm}$	$M = 7$ and 8, sampling: 3 times	$3T_{SMP} + 20$		ns
		$M = 7$ and 8, sampling: 2 times	$2T_{SMP} + 20$		ns
TEMCm0/TEMCm1 low-level width	$t_{TENCLm}$	$M = 7$ and 8, sampling: 3 times	$3T_{SMP} + 20$		ns
		$M = 7$ and 8, sampling: 2 times	$2T_{SMP} + 20$		ns
TECRm high-level width	$t_{TECRHm}$	$M = 7$ and 8, sampling: 3 times	$3T_{SMP} + 20$		ns
		$M = 7$ and 8, sampling: 2 times	$2T_{SMP} + 20$		ns
TECRm low-level width	$t_{TECRLm}$	$M = 7$ and 8, sampling: 3 times	$3T_{SMP} + 20$		ns
		$M = 7$ and 8, sampling: 2 times	$2T_{SMP} + 20$		ns

**Remarks 1.**  $T = 1/f_{XP}$  ( $f_{XP}$ : Peripheral clock frequency (prescaler 1 input clock frequency))

**2.**  $T_{SMP}$ : Noise elimination sampling clock cycle (specified by the ENaNFC register)

**(5) UARTA timing****( $T_A = -40$  to  $+85^\circ\text{C}$ ,  $BV_{DD} \leq V_{DD} = EV_{DD} = AV_{REF0} = AV_{REF1}$ ,  $V_{SS} = EV_{SS} = BV_{SS} = AV_{SS} = 0\text{ V}$ ,  $C_L = 50\text{ pF}$ )**

Parameter	Symbol	Conditions	MIN.	MAX.	Unit
Transmit rate				625	kbps
ASCK0 cycle time				10	MHz

**(6) UARTB timing****( $T_A = -40$  to  $+85^\circ\text{C}$ ,  $BV_{DD} \leq V_{DD} = EV_{DD} = AV_{REF0} = AV_{REF1}$ ,  $V_{SS} = EV_{SS} = BV_{SS} = AV_{SS} = 0\text{ V}$ ,  $C_L = 50\text{ pF}$ )**

Parameter	Symbol	Conditions	MIN.	MAX.	Unit
Transmit rate				1.5	Mbps

&lt;R&gt;

(7) CSIB timing

(a) Master mode

( $T_A = -40$  to  $+85^\circ\text{C}$ ,  $BV_{DD} \leq V_{DD} = EV_{DD} = AV_{REF0} = AV_{REF1}$ ,  $V_{SS} = EV_{SS} = BV_{SS} = AV_{SS} = 0\text{ V}$ ,  $C_L = 50\text{ pF}$ )

Parameter	Symbol	Conditions	MIN.	MAX.	Unit
$\overline{\text{SCKBn}}$ cycle time	$t_{\text{KCY1}}$	<96>	125		ns
$\overline{\text{SCKBn}}$ high-/low-level width	$t_{\text{KH1}}$ , $t_{\text{KL1}}$	<97>	$t_{\text{KCY1}}/2 - 8$		ns
SIBn setup time (to $\overline{\text{SCKBn}}\uparrow$ )	$t_{\text{SIK1}}$	<98>	27		ns
SIBn hold time (from $\overline{\text{SCKBn}}\uparrow$ )	$t_{\text{KSI1}}$	<99>	27		ns
Delay time from $\overline{\text{SCKBn}}\downarrow$ to SOBn output	$t_{\text{KSO1}}$	<100>		27	ns

Remark n = 0 to 5

(b) Slave mode

( $T_A = -40$  to  $+85^\circ\text{C}$ ,  $BV_{DD} \leq V_{DD} = EV_{DD} = AV_{REF0} = AV_{REF1}$ ,  $V_{SS} = EV_{SS} = BV_{SS} = AV_{SS} = 0\text{ V}$ ,  $C_L = 50\text{ pF}$ )

Parameter	Symbol	Conditions	MIN.	MAX.	Unit
$\overline{\text{SCKBn}}$ cycle time	$t_{\text{KCY2}}$	<96>	125		ns
$\overline{\text{SCKBn}}$ high-/low-level width	$t_{\text{KH2}}$ , $t_{\text{KL2}}$	<97>	54.5		ns
SIBn setup time (to $\overline{\text{SCKBn}}\uparrow$ )	$t_{\text{SIK2}}$	<98>	27		ns
SIBn hold time (from $\overline{\text{SCKBn}}\uparrow$ )	$t_{\text{KSI2}}$	<99>	27		ns
Delay time from $\overline{\text{SCKBn}}\downarrow$ to SOBn output	$t_{\text{KSO2}}$	<100>		27	ns

Remark n = 0 to 5

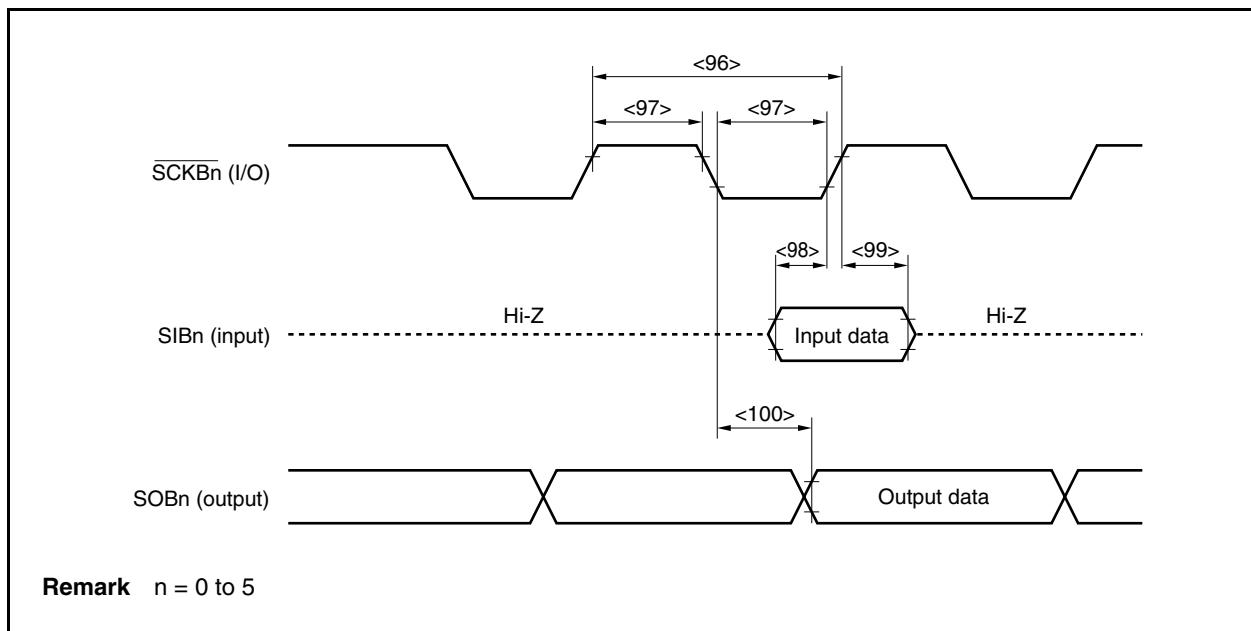



<R> (8) CSIE timing (other than  $\mu$ PD70F3931 (V850E/SJ3-H), 70F3932 (V850E/SJ3-H), and 70F3933 (V850E/SJ3-H))

(a) Master mode

( $T_A = -40$  to  $+85^\circ\text{C}$ ,  $BV_{DD} \leq V_{DD} = EV_{DD} = AV_{REF0} = AV_{REF1}$ ,  $V_{SS} = EV_{SS} = BV_{SS} = AV_{SS} = 0$  V,  $C_L = 50$  pF)

Parameter	Symbol	Conditions	MIN.	MAX.	Unit
SCKEn cycle time	$t_{KCY1}$	<101>	125		ns
SCKEn high-/low-level width	$t_{KH1}$ , $t_{KL1}$	<102>	$t_{KCY1}/2 - 8$		ns
SIEn setup time (to SCKEn $\uparrow$ )	$t_{SIK1}$	<103>	27		ns
SIEn hold time (from SCKEn $\uparrow$ )	$t_{KSI1}$	<104>	27		ns
Delay time from SCKEn $\downarrow$ to SOEn output	$t_{KSO1}$	<105>		27	ns

Remark n = 0, 1

(b) Slave mode

( $T_A = -40$  to  $+85^\circ\text{C}$ ,  $BV_{DD} \leq V_{DD} = EV_{DD} = AV_{REF0} = AV_{REF1}$ ,  $V_{SS} = EV_{SS} = BV_{SS} = AV_{SS} = 0$  V,  $C_L = 50$  pF)

Parameter	Symbol	Conditions	MIN.	MAX.	Unit
SCKEn cycle time	$t_{KCY2}$	<101>	125		ns
SCKEn high-/low-level width	$t_{KH2}$ , $t_{KL2}$	<102>	54.5		ns
SIEn setup time (to SCKEn $\uparrow$ )	$t_{SIK2}$	<103>	27		ns
SIEn hold time (from SCKEn $\uparrow$ )	$t_{KSI2}$	<104>	$(1/f_{XP}) \times 1.5$ + 10		ns
Delay time from SCKEn $\downarrow$ to SOEn output	$t_{KSO2}$	<105>		27	ns

<R>

Remarks 1. n = 0, 1

2.  $f_{XP}$ : Peripheral clock frequency (prescaler 1 input clock frequency)

<R>

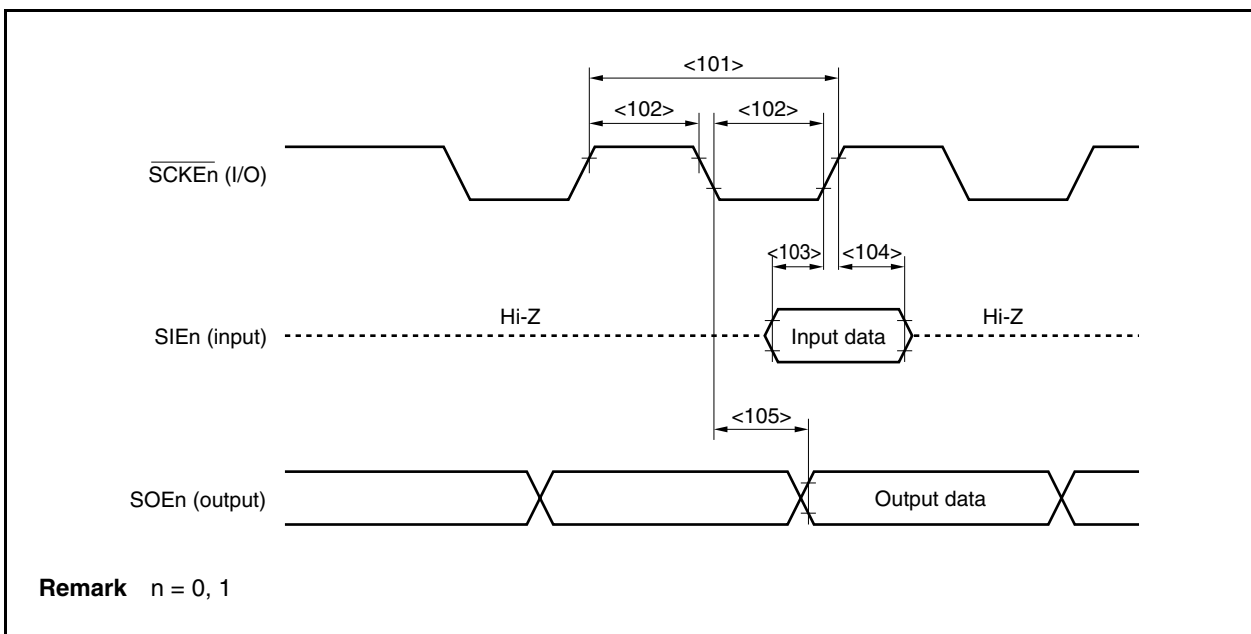

Remark n = 0, 1

(9) I<sup>2</sup>C bus mode(T<sub>A</sub> = -40 to +85°C, V<sub>DD</sub> ≤ V<sub>DD</sub> = E<sub>VDD</sub> = A<sub>VREF0</sub> = A<sub>VREF1</sub>, V<sub>SS</sub> = E<sub>VSS</sub> = B<sub>VSS</sub> = A<sub>VSS</sub> = 0 V, C<sub>L</sub> = 50 pF)

Parameter		Symbol		Normal Mode		High-Speed Mode		Unit
				MIN.	MAX.	MIN.	MAX.	
SCL0n clock frequency		f <sub>CLK</sub>		0	100	0	400	kHz
Bus free time (Between start and stop conditions)		t <sub>BUF</sub>	<106>	4.7	–	1.3	–	μs
Hold time <sup>Note 1</sup>		t <sub>HD: STA</sub>	<107>	4.0	–	0.6	–	μs
SCL0n clock low-level width		t <sub>LOW</sub>	<108>	4.7	–	1.3	–	μs
SCL0n clock high-level width		t <sub>HIGH</sub>	<109>	4.0	–	0.6	–	μs
Setup time for start/restart conditions		t <sub>SU: STA</sub>	<110>	4.7	–	0.6	–	μs
Data hold time	CBUS compatible master	t <sub>HD: DAT</sub>	<111>	5.0	–	–	–	μs
	I <sup>2</sup> C mode			0 <sup>Note 2</sup>	–	0 <sup>Note 2</sup>	0.9 <sup>Note 3</sup>	μs
Data setup time		t <sub>SU: DAT</sub>	<112>	250	–	100 <sup>Note 4</sup>	–	ns
SDA0n and SCL0n signal rise time		t <sub>R</sub>	<113>	–	1000	20 + 0.1Cb <sup>Note 5</sup>	300	ns
SDA0n and SCL0n signal fall time		t <sub>F</sub>	<114>	–	300	20 + 0.1Cb <sup>Note 5</sup>	300	ns
Stop condition setup time		t <sub>SU: STO</sub>	<115>	4.0	–	0.6	–	μs
Pulse width of spike suppressed by input filter		t <sub>SP</sub>	<116>	–	–	0	50	ns
Capacitance load of each bus line		Cb		–	400	–	400	pF

- Notes**
- At the start condition, the first clock pulse is generated after the hold time.
  - The system requires a minimum of 300 ns hold time internally for the SDA0n signal (at V<sub>IHmin.</sub> of SCL0n signal) in order to occupy the undefined area at the falling edge of SCL0n.
  - If the system does not extend the SCL0n signal low hold time (t<sub>LOW</sub>), only the maximum data hold time (t<sub>HD:DAT</sub>) needs to be satisfied.
  - The high-speed mode I<sup>2</sup>C bus can be used in the normal-mode I<sup>2</sup>C bus system. In this case, set the high-speed mode I<sup>2</sup>C bus so that it meets the following conditions.
    - If the system does not extend the SCL0n signal's low state hold time:  
t<sub>SU:DAT</sub> ≥ 250 ns
    - If the system extends the SCL0n signal's low state hold time:  
Transmit the following data bit to the SDA0n line prior to the SCL0n line release (t<sub>Rmax.</sub> + t<sub>SU:DAT</sub> = 1,000 + 250 = 1,250 ns: Normal mode I<sup>2</sup>C bus specification).
  - Cb: Total capacitance of one bus line (unit: pF)

<R> **Remark** Only μPD70F3931 (V850E/SJ3-H), 70F3932 (V850E/SJ3-H), and 70F3933 (V850E/SJ3-H): n = 0 to 3  
Other than μPD70F3931 (V850E/SJ3-H), 70F3932 (V850E/SJ3-H), and 70F3933 (V850E/SJ3-H): n = 0 to 5

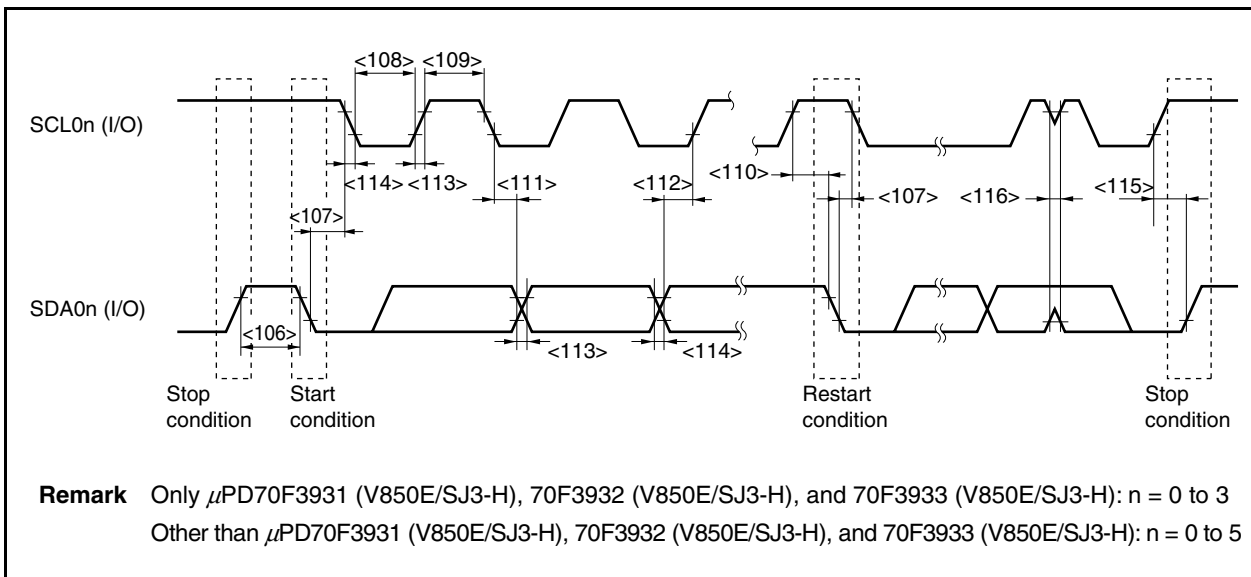

<R>

(10) IEBus Controller

( $T_A = -40$  to  $+85^\circ\text{C}$ ,  $BV_{DD} \leq V_{DD} = EV_{DD} = AV_{REF0} = AV_{REF1}$ ,  $V_{SS} = EV_{SS} = BV_{SS} = AV_{SS} = 0\text{ V}$ ,  $C_L = 50\text{ pF}$ )

Parameter	Symbol	Conditions	MIN.	TYP.	MAX.	Unit
IEBus system clock frequency	fs	Communication mode: Modes 1, 2	5.91	6.00 <sup>Note</sup>	6.09	MHz
			6.20	6.29 <sup>Note</sup>	6.38	MHz

**Note** IEBus system clock frequencies 6.0 MHz and 6.29 MHz cannot be used together.

(11) CAN timing (products with CAN controller only)

( $T_A = -40$  to  $+85^\circ\text{C}$ ,  $BV_{DD} \leq V_{DD} = EV_{DD} = AV_{REF0} = AV_{REF1}$ ,  $V_{SS} = EV_{SS} = BV_{SS} = AV_{SS} = 0\text{ V}$ ,  $C_L = 50\text{ pF}$ )

Parameter	Symbol	Conditions	MIN.	MAX.	Unit
Transmit rate				1	Mbps
Internal delay time	$t_{NODE}$			100	ns

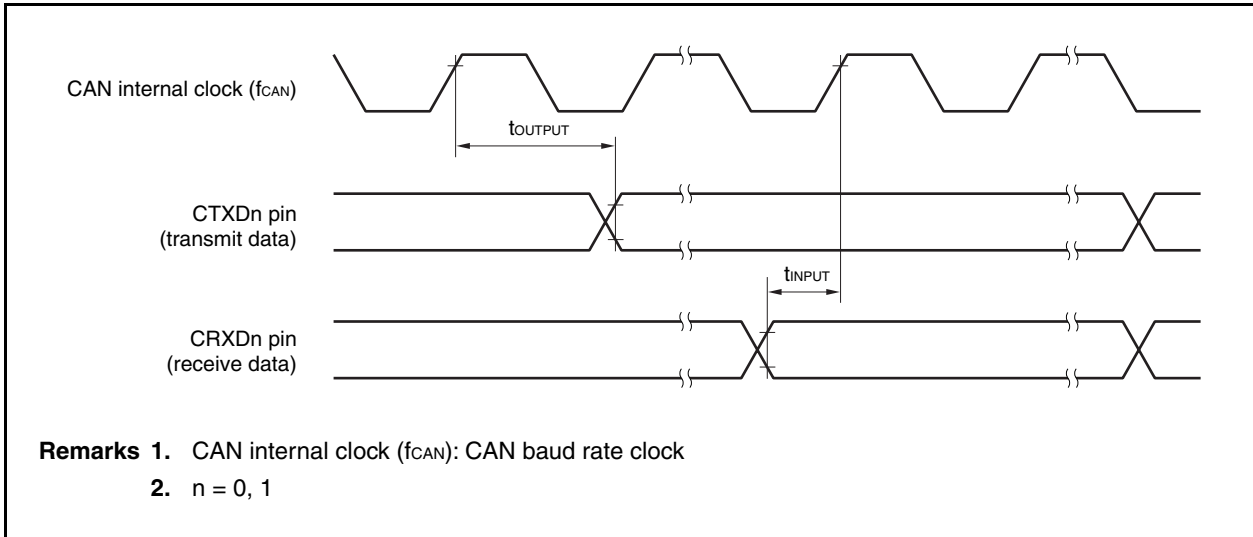

Internal delay time ( $t_{NODE}$ ) = Internal transmission delay time ( $t_{OUTPUT}$ ) + Internal reception delay time ( $t_{INPUT}$ )

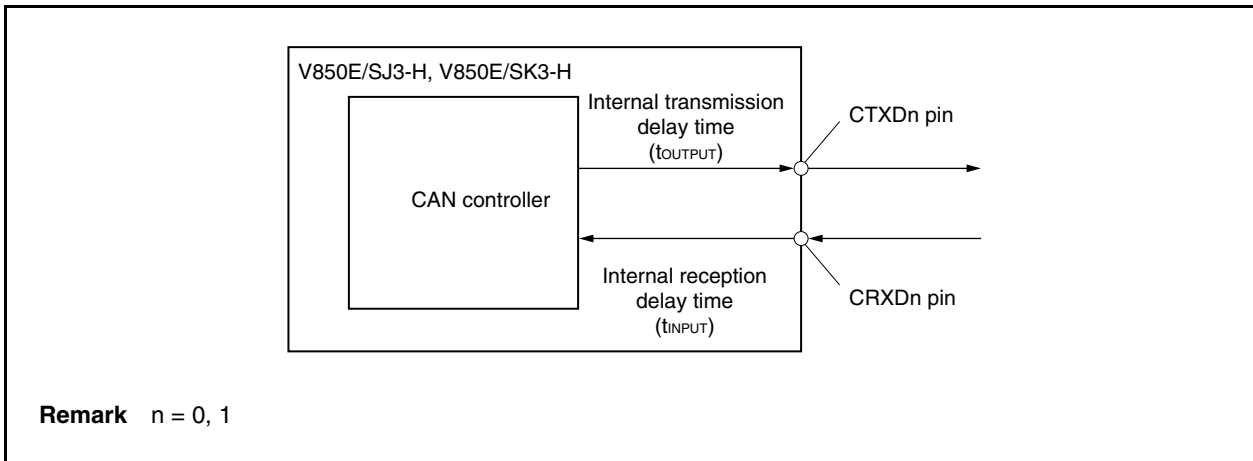

**(12) A/D converter**

( $T_A = -40$  to  $+85^\circ\text{C}$ ,  $BV_{DD} \leq V_{DD} = EV_{DD} = AV_{REF0} = AV_{REF1}$ ,  $3.0\text{ V} \leq AV_{REF0} \leq 3.6\text{ V}$ ,  $V_{SS} = EV_{SS} = BV_{SS} = AV_{SS} = 0\text{ V}$ ,  $C_L = 50\text{ pF}$ )

Parameter	Symbol	Conditions	MIN.	TYP.	MAX.	Unit
Resolution					10	bit
Overall error <sup>Note</sup>		$3.0 \leq AV_{REF0} \leq 3.6\text{ V}$			$\pm 0.6$	%FSR
Conversion time	$t_{CONV}$		2.6		24	$\mu\text{s}$
Zero scale error					$\pm 0.5$	%FSR
Full scale error					$\pm 0.5$	%FSR
Non-linearity error					$\pm 4.0$	LSB
Differential linearity error					$\pm 4.0$	LSB
Analog input voltage	$V_{IAN}$		$AV_{SS}$		$AV_{REF0}$	V
Reference voltage	$AV_{REF0}$		3.0		3.6	V
$AV_{REF0}$ current	$AI_{REF0}$	Normal conversion mode		3	6.5	mA
		High-speed conversion mode		4	10	mA
		When A/D converter unused			5	$\mu\text{A}$

**Note** Excluding quantization error ( $\pm 0.05\%$ FSR).

**Caution** Do not set (read/write) alternate-function ports during A/D conversion; otherwise the conversion resolution may be degraded.

**Remark** LSB: Least Significant Bit  
FSR: Full Scale Range

**(13) D/A Converter**

( $T_A = -40$  to  $+85^\circ\text{C}$ ,  $BV_{DD} \leq V_{DD} = EV_{DD} = AV_{REF0} = AV_{REF1}$ ,  $3.0\text{ V} \leq AV_{REF1} \leq 3.6\text{ V}$ ,  $V_{SS} = EV_{SS} = BV_{SS} = AV_{SS} = 0\text{ V}$ ,  $C_L = 50\text{ pF}$ )

Parameter	Symbol	Conditions	MIN.	TYP.	MAX.	Unit
Resolution					8	bit
Overall error <sup>Note 1</sup>		$R = 2\text{ M}\Omega$			$\pm 1.2$	%FSR
Settling time		$C = 20\text{ pF}$			3	$\mu\text{s}$
Output resistor	$R_O$	Output data 55H		6.42		$\text{k}\Omega$
Reference voltage	$AV_{REF1}$		3.0		3.6	V
$AV_{REF1}$ current <sup>Note 2</sup>	$AI_{REF1}$	D/A conversion operating		1	2.5	mA
		D/A conversion stopped			5	$\mu\text{A}$

**Notes** 1. Excluding quantization error ( $\pm 0.5$  LSB).  
2. Value of 1 channel of D/A converter

**Remark** R is the output pin load resistance and C is the output pin load capacitance.

(14) LVI circuit specification

( $T_A = -40$  to  $+85^\circ\text{C}$ ,  $BV_{DD} \leq V_{DD} = EV_{DD} = AV_{REF0} = AV_{REF1}$ ,  $V_{SS} = EV_{SS} = BV_{SS} = AV_{SS} = 0$  V,  $C_L = 50$  pF)

Parameter	Symbol	Conditions	MIN.	TYP.	MAX.	Unit
Detection voltage	$V_{LV10}$		2.85	2.95	3.05	V
Response time <sup>Note</sup>	$t_{LD}$	After $V_{DD}$ reaches $V_{LV10}$ (MAX.), or after $V_{DD}$ has dropped to $V_{LV10}$ (MAX.)		0.2	2.0	ms
Minimum pulse width	$t_{LW}$		0.2			ms
Reference voltage stabilization wait time	$t_{LWAIT}$	After $V_{DD}$ reaches 2.85 V (MIN.)		0.1	0.2	ms

**Note** Time required to detect the detection voltage and output an interrupt or reset signal.

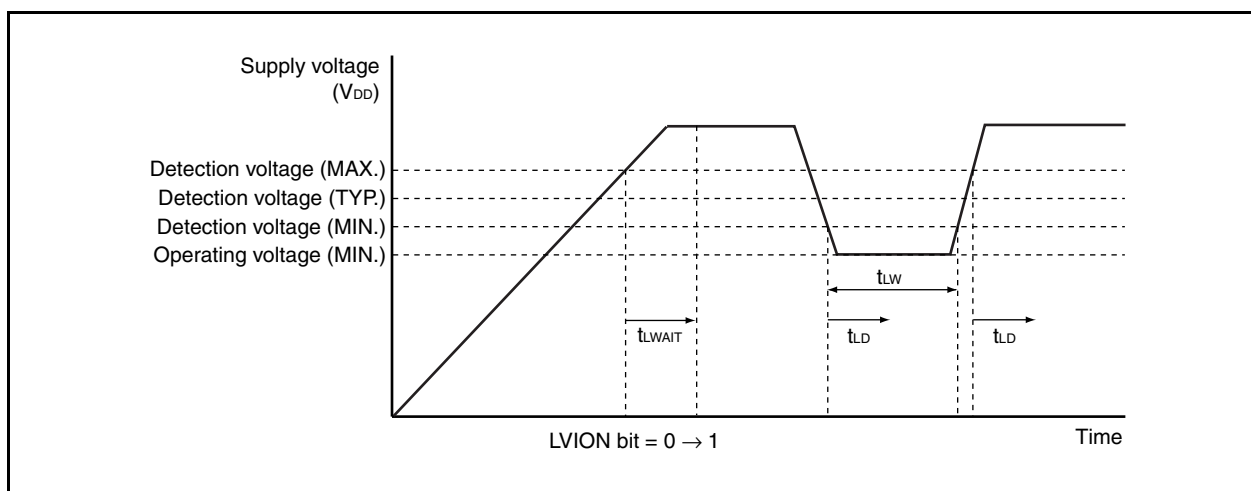

(15) RAM retention detection

( $T_A = -40$  to  $+85^\circ\text{C}$ ,  $BV_{DD} \leq V_{DD} = EV_{DD} = AV_{REF0} = AV_{REF1}$ ,  $V_{SS} = EV_{SS} = BV_{SS} = AV_{SS} = 0$  V,  $C_L = 50$  pF)

Parameter	Symbol	Conditions	MIN.	TYP.	MAX.	Unit
Detection voltage	$V_{RAMH}$		1.9	2.0	2.1	V
Supply voltage rise time	$t_{RAMHTH}$	$V_{DD} = 0$ to 2.85 V	0.002			ms
Response time <sup>Note</sup>	$t_{RAMHD}$	After $V_{DD}$ reaches 2.1 V		0.2	3.0	ms
Minimum pulse width	$t_{RAMHW}$		0.2			ms

**Note** Time required to detect the detection voltage and set the RAMS.RAMF bit.

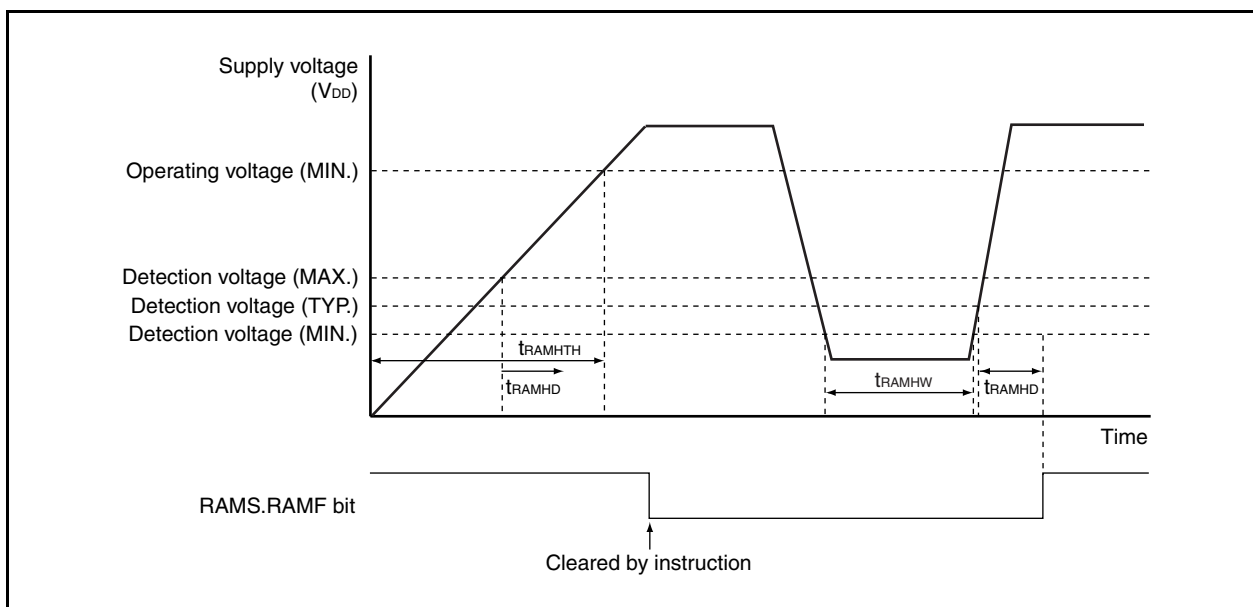

### 35.10 Flash Memory Programming Characteristics

( $T_A = -40$  to  $+85^\circ\text{C}$ ,  $BV_{DD} \leq V_{DD} = EV_{DD} = AV_{REF0} = AV_{REF1}$ ,  $V_{SS} = EV_{SS} = BV_{SS} = AV_{SS} = 0\text{ V}$ ,  $C_L = 50\text{ pF}$ )

#### (1) Basic characteristics

Parameter	Symbol	Conditions	MIN.	TYP.	MAX.	Unit
Operating frequency	$f_{CPU}$		3.0		48	MHz
Supply voltage	$V_{DD}$		2.85		3.6	V
Number of rewrites	$C_{WRT}$				1000	times
Programming temperature	$t_{PRG}$		-40		+85	$^\circ\text{C}$

#### (2) Serial write operation characteristics

Parameter	Symbol	Conditions	MIN.	TYP.	MAX.	Unit
FLMD0, FLMD1 setup time	$t_{MDSET}$		2		3000	ms
FLMD0 count start time from $\overline{\text{RESET}} \uparrow$	$t_{RFCF}$	$f_x = 3.0$ to $10\text{ MHz}$	800			$\mu\text{s}$
FLMD0 counter high-level width/ low-level width	$t_{CH}/t_{CL}$		10		100	$\mu\text{s}$
FLMD0 counter rise time/fall time	$t_R/t_F$				1	$\mu\text{s}$

#### Flash write mode setup timing

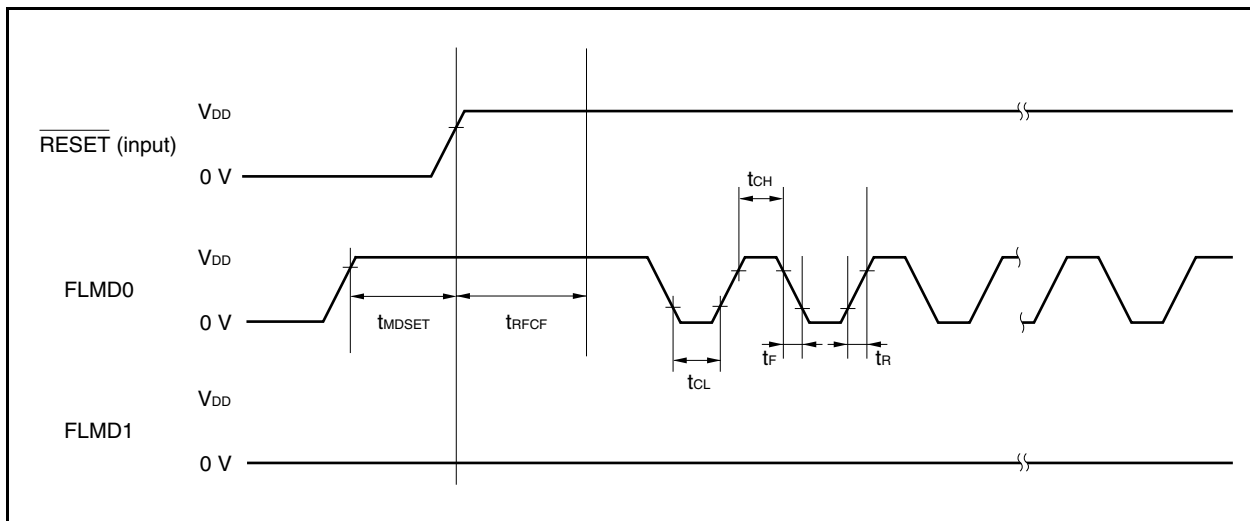



**(3) Programming characteristics**

&lt;R&gt;

&lt;R&gt;

Parameter	Symbol	Conditions	MIN.	TYP.	MAX.	Unit
Chip erase time		f <sub>xx</sub> = 48 MHz, Batch erasure		90.6		ms
Write time per 256 bytes		f <sub>xx</sub> = 48 MHz		1.7		ms
Block internal verify time		f <sub>xx</sub> = 48 MHz		10		ms
Block blank check time		f <sub>xx</sub> = 48 MHz		0.5		ms
Flash memory information setting time		f <sub>xx</sub> = 48 MHz		30		ms

**Caution** When writing initially to shipped products, it is counted as one rewrite for both “erase to write” and “write only”.

**Example (P: Write, E: Erase)**

Shipped product → P → E → P → E → P: 3 rewrites

Shipped product → E → P → E → P → E → P: 3 rewrites

**Remark** The block size is 4 KB.

CHAPTER 36 PACKAGE DRAWINGS

144-PIN PLASTIC LQFP (FINE PITCH) (20x20)

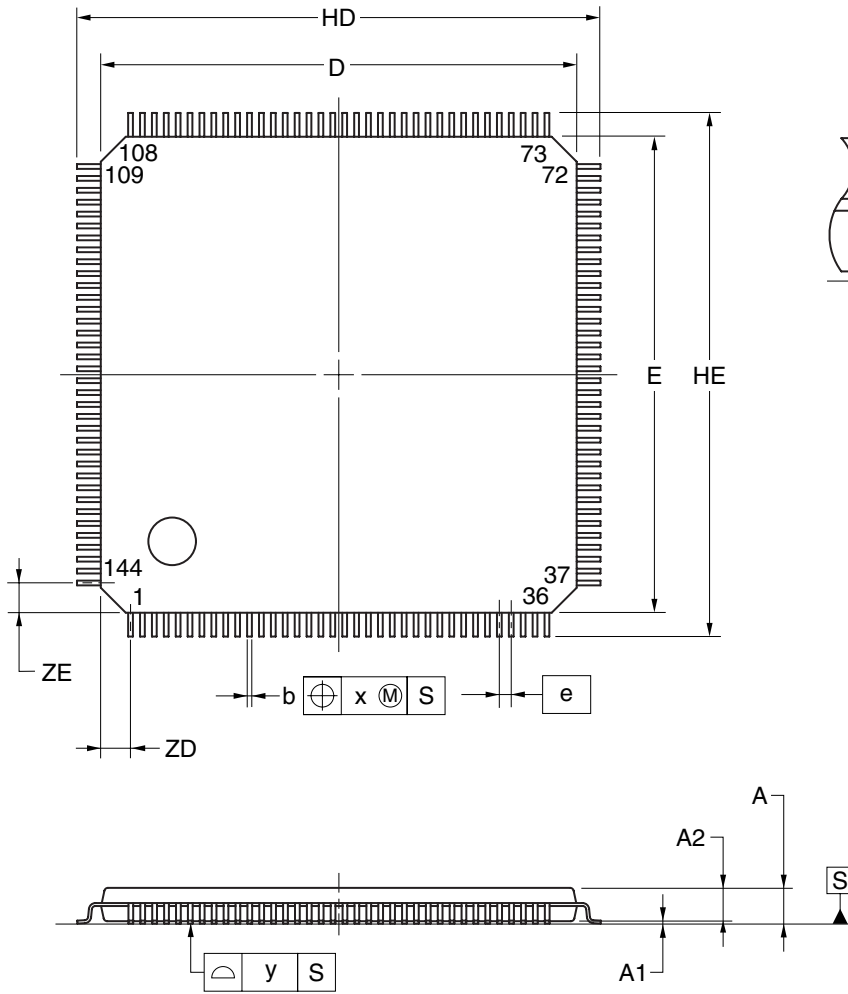

(UNIT:mm)

ITEM	DIMENSIONS
D	20.00±0.20
E	20.00±0.20
HD	22.00±0.20
HE	22.00±0.20
A	1.60 MAX.
A1	0.10±0.05
A2	1.40±0.05
A3	0.25
b	0.20 <sup>+0.07</sup> <sub>-0.03</sub>
c	0.125 <sup>+0.075</sup> <sub>-0.025</sub>
L	0.50
Lp	0.60±0.15
L1	1.00±0.20
θ	3° <sup>+4°</sup> <sub>-3°</sub>
e	0.50
x	0.08
y	0.08
ZD	1.25
ZE	1.25

P144GJ-50-GAE-2

© NEC Electronics Corporation 2008

### 176-PIN PLASTIC LQFP (FINE PITCH) (24x24)

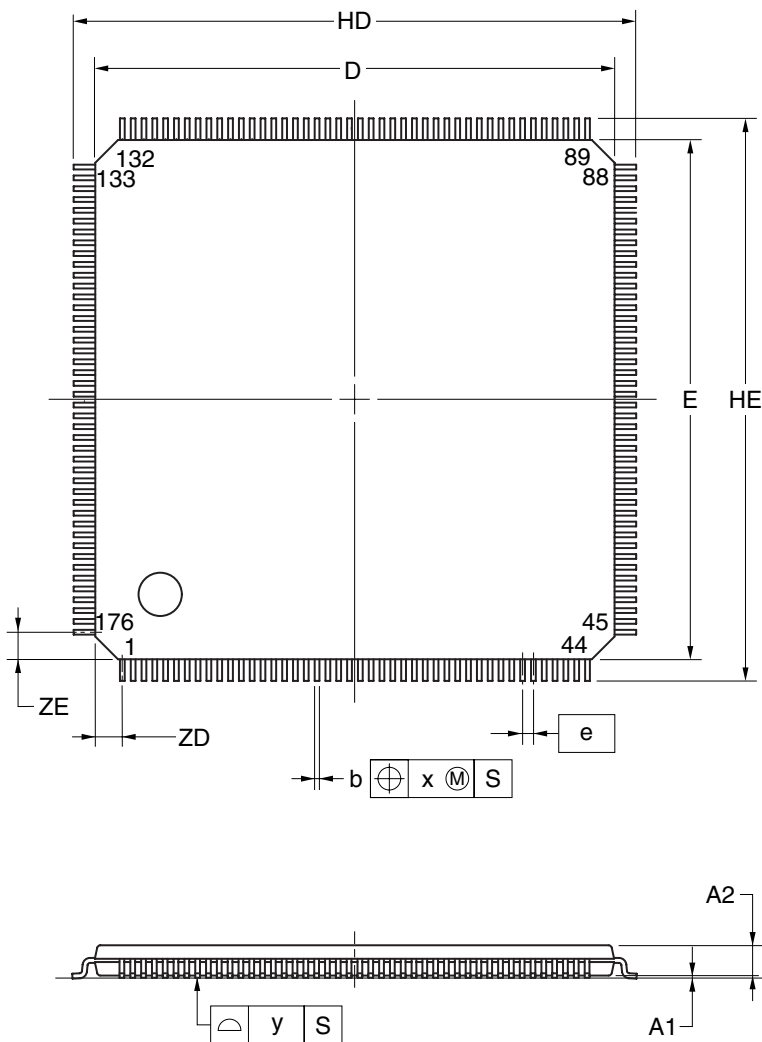

detail of lead end

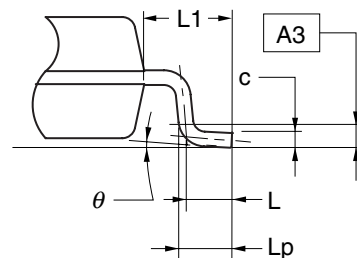

(UNIT:mm)

ITEM	DIMENSIONS
D	24.00±0.20
E	24.00±0.20
HD	26.00±0.20
HE	26.00±0.20
A	1.60 MAX.
A1	0.10±0.05
A2	1.40±0.05
A3	0.25
b	0.20 <sup>+0.07</sup> <sub>-0.03</sub>
c	0.125 <sup>+0.075</sup> <sub>-0.025</sub>
L	0.50
Lp	0.60±0.15
L1	1.00±0.20
$\theta$	3° <sup>+5°</sup> <sub>-3°</sub>
e	0.50
x	0.08
y	0.08
ZD	1.25
ZE	1.25

**NOTE**

Each lead centerline is located within 0.08 mm of its true position at maximum material condition.

P176GM-50-GAR

© NEC Electronics Corporation 2005

## CHAPTER 37 RECOMMENDED SOLDERING CONDITIONS

The V850E/SJ3-H and V850E/SK3-H should be soldered and mounted under the following recommended conditions.

For technical information, see the following website.

Semiconductor Device Mount Manual (<http://www.necel.com/pkg/en/mount/index.html>)

**Table 37-1. Surface Mounting Type Soldering Conditions (1/2)**

- μPD70F3474GJA-GAE-G: 144-pin plastic LQFP (fine pitch) (20 × 20)**
- μPD70F3475GJA-GAE-G: 144-pin plastic LQFP (fine pitch) (20 × 20)**
- μPD70F3476GJA-GAE-G: 144-pin plastic LQFP (fine pitch) (20 × 20)**
- μPD70F3477GJA-GAE-G: 144-pin plastic LQFP (fine pitch) (20 × 20)**
- μPD70F3478GJA-GAE-G: 144-pin plastic LQFP (fine pitch) (20 × 20)**
- μPD70F3479GJA-GAE-G: 144-pin plastic LQFP (fine pitch) (20 × 20)**
- <R> μPD70F3931GJA-GAE-G: 144-pin plastic LQFP (fine pitch) (20 × 20)**
- <R> μPD70F3932GJA-GAE-G: 144-pin plastic LQFP (fine pitch) (20 × 20)**
- <R> μPD70F3933GJA-GAE-G: 144-pin plastic LQFP (fine pitch) (20 × 20)**
- <R> μPD70F3934GJA-GAE-G: 144-pin plastic LQFP (fine pitch) (20 × 20)**
- <R> μPD70F3935GJA-GAE-G: 144-pin plastic LQFP (fine pitch) (20 × 20)**
- <R> μPD70F3936GJA-GAE-G: 144-pin plastic LQFP (fine pitch) (20 × 20)**
- <R> μPD70F3937GJA-GAE-G: 144-pin plastic LQFP (fine pitch) (20 × 20)**
- <R> μPD70F3938GJA-GAE-G: 144-pin plastic LQFP (fine pitch) (20 × 20)**
- <R> μPD70F3939GJA-GAE-G: 144-pin plastic LQFP (fine pitch) (20 × 20)**

Soldering Method	Soldering Conditions	Recommended Condition Symbol
Infrared reflow	Package peak temperature: 260°C, Time: 60 seconds max. (at 220°C or higher), Count: Three times or less, Exposure limit: 7 days <sup>Note</sup> (after that, prebake at 125°C for 20 to 72 hours)	IR60-207-3
Partial heating	Pin temperature: 350°C max., Time: 3 seconds max. (per pin row)	—

**Note** After opening the dry pack, store it at 25°C or less and 65% RH or less for the allowable storage period.

- Remarks**
1. Products with -G at the end of the part number are lead-free products.
  2. For soldering methods and conditions other than those recommended above, please contact an NEC Electronics sales representative.

Table 37-1. Surface Mounting Type Soldering Conditions (2/2)

$\mu$ PD70F3480GMA-GAR-G: 176-pin plastic LQFP (fine pitch) (24 × 24)

$\mu$ PD70F3481GMA-GAR-G: 176-pin plastic LQFP (fine pitch) (24 × 24)

$\mu$ PD70F3482GMA-GAR-G: 176-pin plastic LQFP (fine pitch) (24 × 24)

$\mu$ PD70F3486GMA-GAR-G: 176-pin plastic LQFP (fine pitch) (24 × 24)

$\mu$ PD70F3487GMA-GAR-G: 176-pin plastic LQFP (fine pitch) (24 × 24)

$\mu$ PD70F3488GMA-GAR-G: 176-pin plastic LQFP (fine pitch) (24 × 24)

$\mu$ PD70F3925GMA-GAR-G: 176-pin plastic LQFP (fine pitch) (24 × 24)

$\mu$ PD70F3926GMA-GAR-G: 176-pin plastic LQFP (fine pitch) (24 × 24)

$\mu$ PD70F3927GMA-GAR-G: 176-pin plastic LQFP (fine pitch) (24 × 24)

Soldering Method	Soldering Conditions	Recommended Condition Symbol
Infrared reflow	Package peak temperature: 260°C, Time: 60 seconds max. (at 220°C or higher), Count: Three times or less, Exposure limit: 7 days <sup>Note</sup> (after that, prebake at 125°C for 20 to 72 hours)	IR60-207-3
Partial heating	Pin temperature: 350°C max., Time: 3 seconds max. (per pin row)	—

**Note** After opening the dry pack, store it at 25°C or less and 65% RH or less for the allowable storage period.

**Remarks 1.** Products with -G at the end of the part number are lead-free products.

**2.** For soldering methods and conditions other than those recommended above, please contact an NEC Electronics sales representative.

## APPENDIX A DEVELOPMENT TOOLS

The following development tools are available for the development of systems that employ the V850E/SJ3-H and V850E/SK3-H.

Figure A-1 shows the development tool configuration.

- **Support for PC98-NX series**

Unless otherwise specified, products supported by IBM PC/AT™ compatibles are compatible with PC98-NX series computers. When using PC98-NX series computers, refer to the explanation for IBM PC/AT compatibles.

- **Windows®**

Unless otherwise specified, “Windows” means the following OSs.

- Windows 98
- Windows 2000
- Windows Me
- Windows XP
- Windows NT® Ver. 4.0

Figure A-1. Development Tool Configuration (1/4)

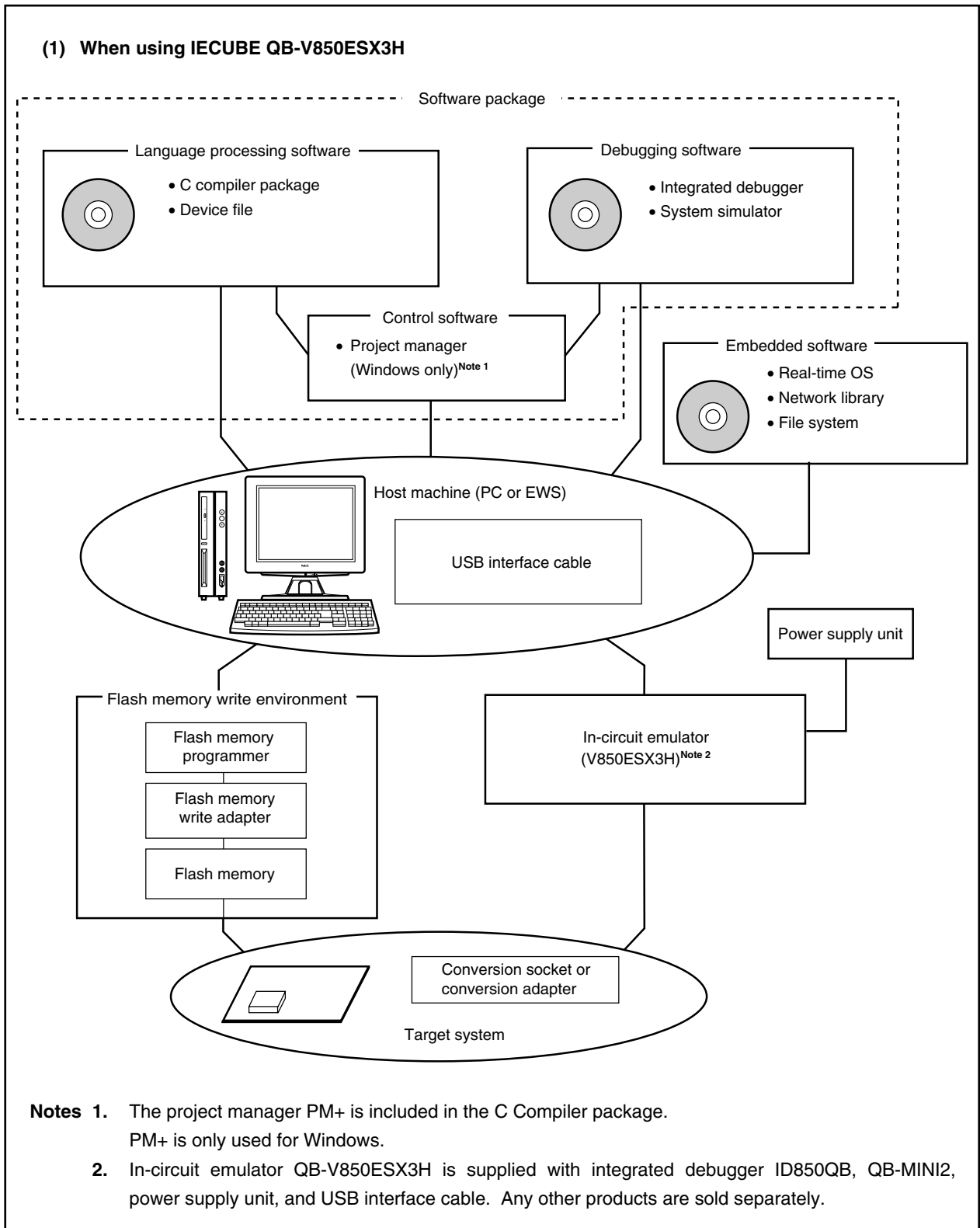

Figure A-1. Development Tool Configuration (2/4)

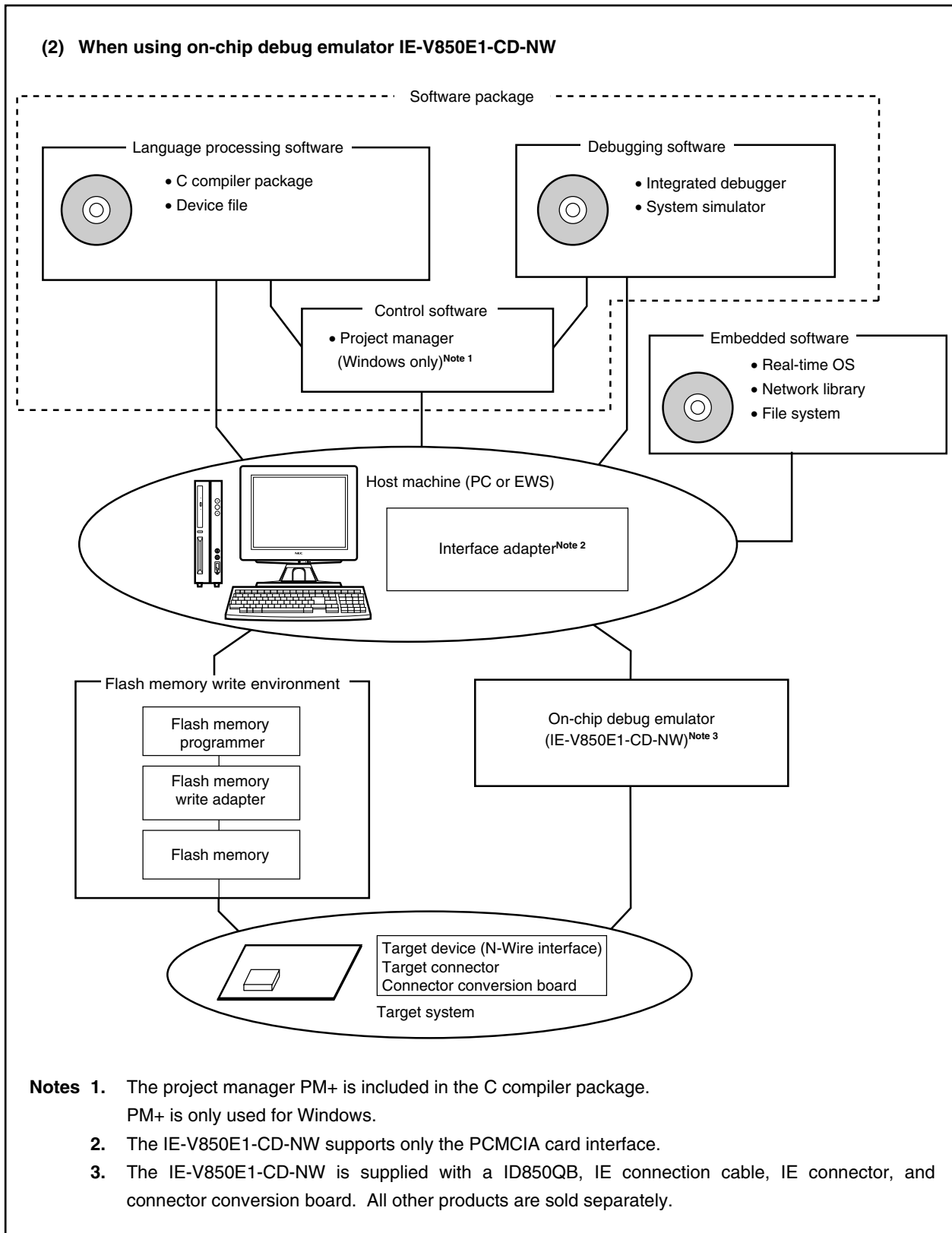



Figure A-1. Development Tool Configuration (3/4)

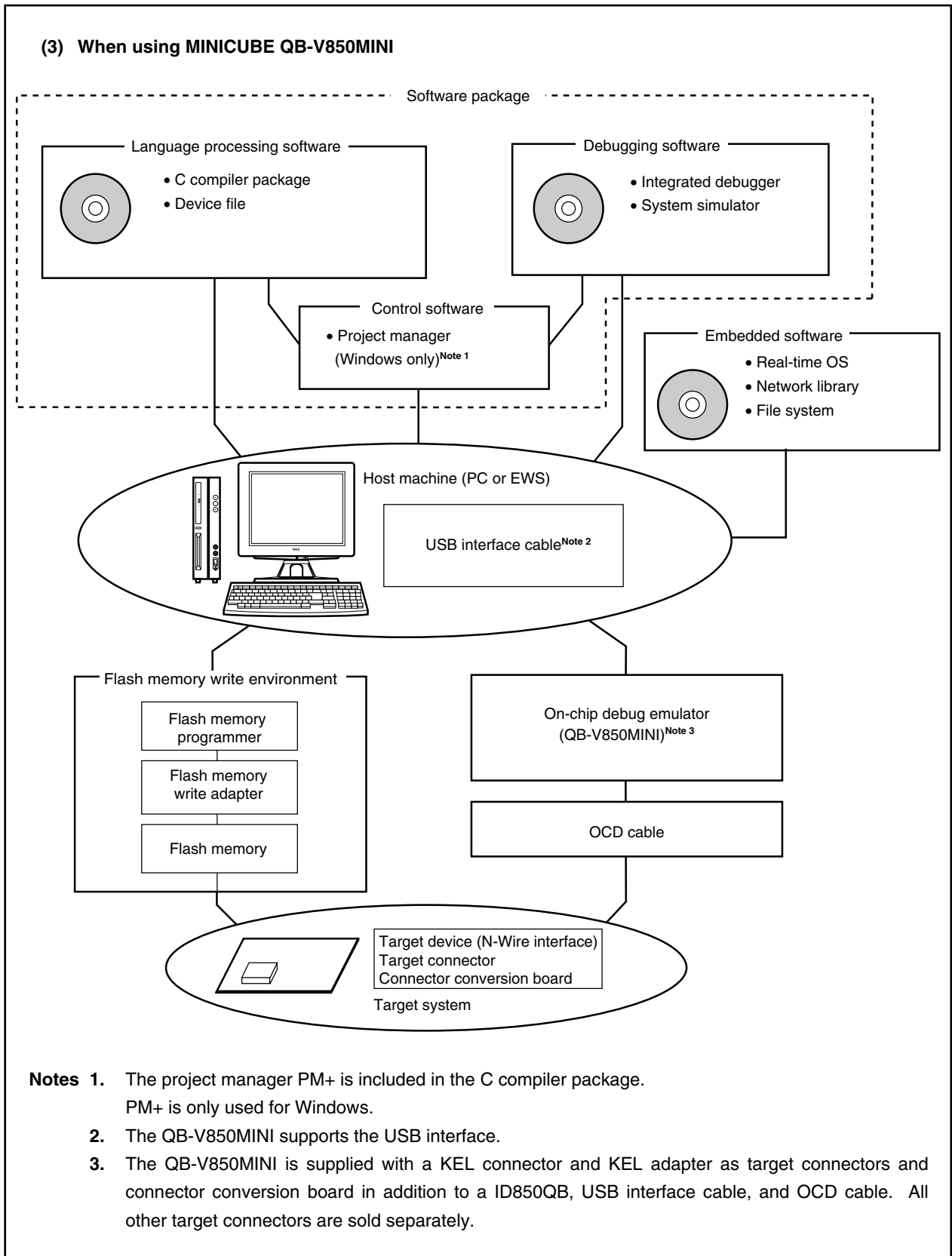
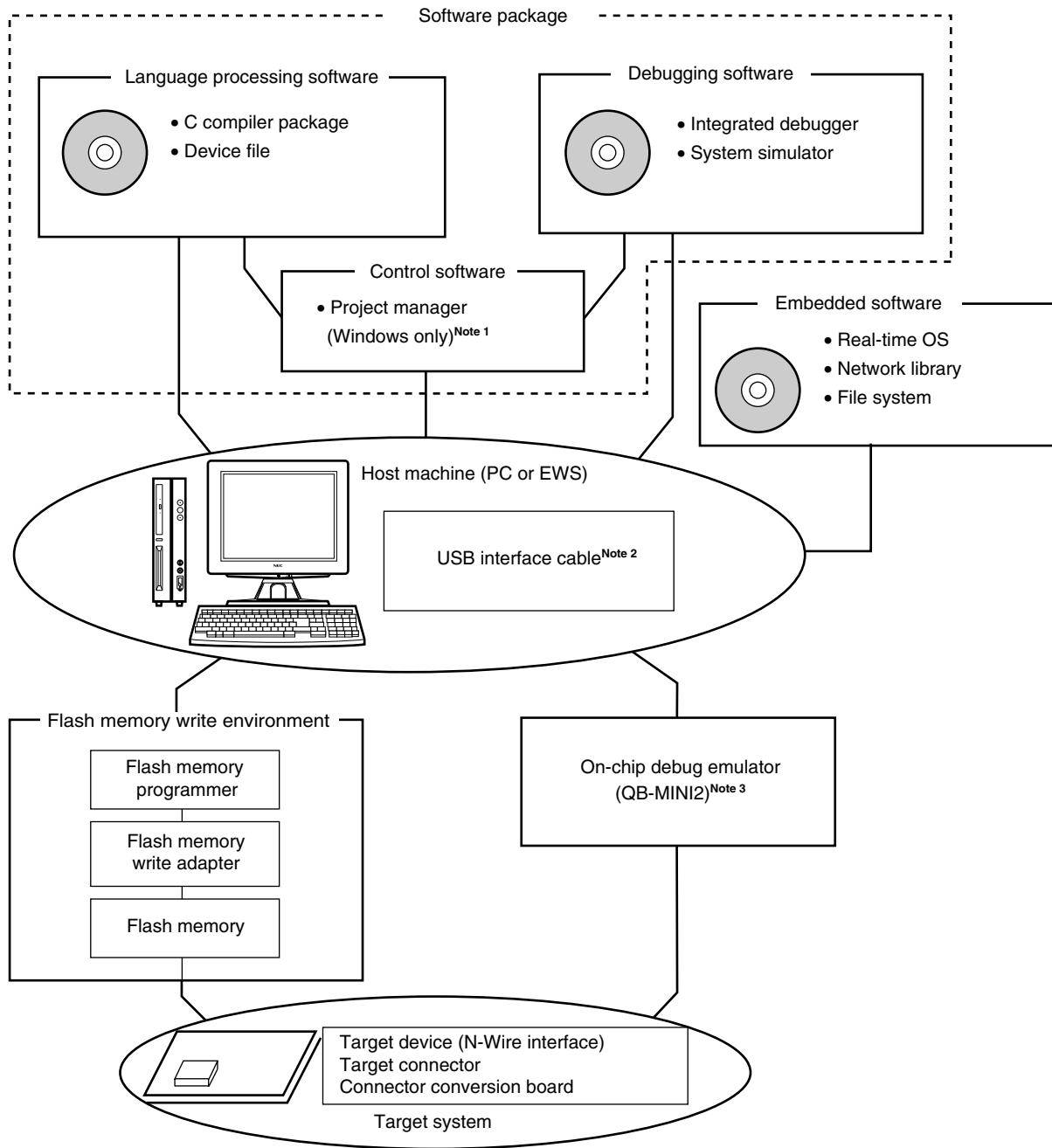

Figure A-1. Development Tool Configuration (4/4)

<R>

(4) When using MINICUBE2 QB-MINI2



- Notes**
1. The project manager PM+ is included in the C compiler package. PM+ is only used for Windows.
  2. The QB-MINI2 supports the USB interface.
  3. The QB-MINI2 is supplied with USB interface cable, 16-pin target cable, 10-pin target cable, and 78K0-OCD board (integrated debugger is not supplied.). All other products are optional.

### A.1 Software Package

SP850 V850 microcontroller software package	Development tools (software) common to the V850 microcontroller are combined in this package.
	Part number: $\mu$ SxxxxSP850

**Remark** xxxx in the part number differs depending on the host machine and OS used.

$\mu$ SxxxxSP850

xxxx	Host Machine	OS	Supply Medium
AB17	PC-9800 series,	Windows (Japanese version)	CD-ROM
BB17	IBM PC/AT compatibles	Windows (English version)	

### A.2 Language Processing Software

CA850 C compiler package	This compiler converts programs written in C language into object codes executable with a microcontroller. This compiler is started from project manager PM+. Part number: $\mu$ SxxxxCA703000
DF703482 Device file	This file contains information peculiar to the device. This device file should be used in combination with a tool (CA850 and ID850QB). The corresponding OS and host machine differ depending on the tool to be used.

**Remark** xxxx in the part number differs depending on the host machine and OS used.

$\mu$ SxxxxCA703000

xxxx	Host Machine	OS	Supply Medium
AB17	PC-9800 series,	Windows (Japanese version)	CD-ROM
BB17	IBM PC/AT compatibles	Windows (English version)	
3K17	SPARCstation™	SunOS™ (Rel. 4.1.4), Solaris™ (Rel. 2.5.1)	

### A.3 Control Software

PM+ Project manager	This is control software designed to enable efficient user program development in the Windows environment. All operations used in development of a user program, such as starting the editor, building, and starting the debugger, can be performed from PM+. <b>&lt;Caution&gt;</b> PM+ is included in the C compiler package CA850. It can only be used in Windows.
------------------------	--

**A.4 Debugging Tools (Hardware)**

**<R> A.4.1 When using IECUBE QB-V850ESX3H**

The system configuration when connecting the QB-V850ESX3H to the host machine (PC-9821 series, PC/AT compatible) is shown below. Even if optional products are not prepared, connection is possible.

**Figure A-2. System Configuration (When Using QB-V850ESX3H) (1/2)**

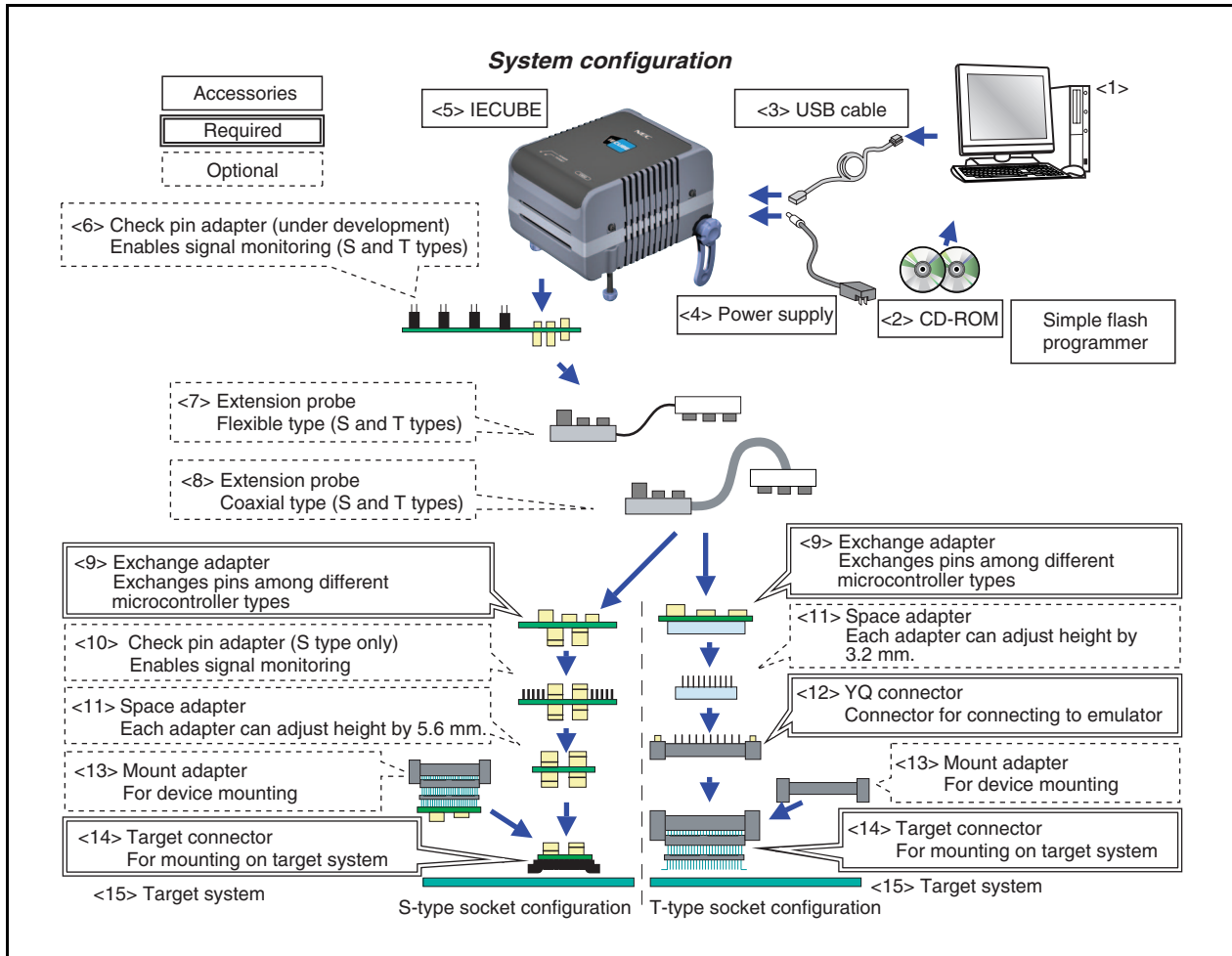

Figure A-2. System Configuration (When Using QB-V850ESX3H) (2/2)

- <1> Host machine (PC-9821 series, IBM-PC/AT compatibles)
- <2> Debugger, USB driver, manuals, etc. (ID850QB Disk, Accessory Disk<sup>Note 1</sup>)
- <3> USB interface cable
- <4> AC adapter
- <5> In-circuit emulator (QB-V850ESX3H)
- <6> Check pin adapter (S and T types) (QB-144-CA-01) (optional)
- <7> Extension probe (flexible type) (S and T types) (QB-144-EP-02S (GJ package), QB-208-EP-02S (GM package)) (optional)
- <8> Extension probe (coaxial type) (S and T types) (QB-144-EP-01S) (optional)
- <9> Exchange adapter<sup>Note 2</sup> (S type: QB-144GJ-EA-01S (GJ package), QB-176GM-EA-02S (GM package), T type: QB-144GJ-EA-01T (GJ package), QB-176GM-EA-02T (GM package))
- <10> Check pin adapter<sup>Note 3</sup> (S type only: QB-144-CA-01S (GJ package), QB-176-CA-01S (GM package)) (optional)
- <11> Space adapter<sup>Note 3</sup> (S type: QB-144-SA-01S (GJ package), QB-176-SA-01S (GM package), T type: QB-144GJ-YS-01T (GJ package), QB-176GM-YS-01T (GM package)) (optional)
- <12> YQ connector<sup>Note 2</sup> (T type only) (QB-144GJ-YQ-01T) (GJ package), QB-176GM-YQ-01T (GM package)
- <13> Mount adapter (S type: QB-144GJ-MA-01S (GJ package), QB-176GM-MA-01S (GM package), T type: QB-144GJ-HQ-01T (GJ package), QB-176GM-HQ-01T (GM package)) (optional)
- <14> Target connector<sup>Note 2</sup> (S type: QB-144GJ-TC-01S (GJ package), QB-176GM-TC-01S (GM package), T type: QB-144GJ-NQ-01T (GJ package), QB-176GM-NQ-01T (GM package))
- <15> Target system

- Notes**
1. Download the device file from the NEC Electronics website.  
<http://www.necel.com/micro/ods/eng/>
  2. Supplied with the device depending on the ordering number.
    - When QB-V850ESX3H-ZZZ is ordered  
The exchange adapter and the target connector are not supplied.
    - When QB-V850ESX3H-S144GJ is ordered  
The QB-144GJ-EA-01S and QB-144GJ-TC-01S are supplied.
    - When QB-V850ESX3H-S176GM is ordered  
The QB-176GM-EA-02S and QB-176GM-TC-01S are supplied.
    - When QB-V850ESX3H-T144GJ is ordered  
The QB-144GJ-EA-01T, QB-144GJ-YQ-01T, and QB-144GJ-NQ-01T are supplied.
    - When QB-V850ESX3H-T176GM is ordered  
The QB-176GM-EA-02T, QB-176GM-YQ-01T, and QB-176GM-NQ-01T are supplied.
  3. When using both <10> and <11>, the order between <10> and <11> is not cared.

<p>&lt;5&gt; QB-V850ESX3H<sup>Note</sup> In-circuit emulator</p>	<p>The in-circuit emulator serves to debug hardware and software when developing application systems using the V850E/SJ3-H or V850E/SK3-H. It supports the integrated debugger ID850QB. This emulator should be used in combination with a power supply unit and emulation probe. Use the USB interface cable to connect this emulator to the host machine.</p>
<p>&lt;3&gt; USB interface cable</p>	<p>Cable to connect the host machine and the QB-V850ESX3H.</p>
<p>&lt;4&gt; AC adapter</p>	<p>100 to 240 V can be supported by replacing the AC plug.</p>
<p>&lt;9&gt; QB-144GJ-EA-01S QB-176GM-EA-02S QB-144GJ-EA-01T QB-176GM-EA-02T Exchange adapter</p>	<p>Adapter to perform pin conversion.</p> <ul style="list-style-type: none"> <li>• QB-144GJ-EA-01S: 144-pin plastic LQFP (GJ-GAE type)</li> <li>• QB-176GM-EA-02S: 176-pin plastic LQFP (GM-GAR type)</li> <li>• QB-144GJ-EA-01T: 144-pin plastic LQFP (GJ-GAE type)</li> <li>• QB-176GM-EA-02T: 176-pin plastic LQFP (GM-GAR type)</li> </ul>
<p>&lt;10&gt; QB-144-CA-01S QB-176-CA-01S (S type only) Check pin adapter</p>	<p>Adapter used in waveform monitoring using the oscilloscope, etc.</p> <ul style="list-style-type: none"> <li>• QB-144-CA-01S: 144-pin plastic LQFP (GJ-GAE type)</li> <li>• QB-176-CA-01S: 176-pin plastic LQFP (GM-GAR type)</li> </ul>
<p>&lt;11&gt; QB-144-SA-01S QB-176-SA-01S QB-144GJ-YS-01T QB-176GM-YS-01T Space adapter</p>	<p>Adapter to adjust the height.</p> <ul style="list-style-type: none"> <li>• QB-144-SA-01S: 144-pin plastic LQFP (GJ-GAE type)</li> <li>• QB-176-SA-01S: 176-pin plastic LQFP (GM-GAR type)</li> <li>• QB-144GJ-YS-01T: 144-pin plastic LQFP (GJ-GAE type)</li> <li>• QB-176GM-YS-01T: 176-pin plastic LQFP (GM-GAR type)</li> </ul>
<p>&lt;12&gt; QB-144GJ-YQ-01T QB-176GM-YQ-01T (T type only) YQ connector</p>	<p>Conversion adapter to connect target connector and exchange adapter</p> <ul style="list-style-type: none"> <li>• QB-144GJ-YQ-01T: 144-pin plastic LQFP (GJ-GAE type)</li> <li>• QB-176GM-YQ-01T: 176-pin plastic LQFP (GM-GAR type)</li> </ul>
<p>&lt;13&gt; QB-144GJ-MA-01S QB-176GM-MA-01S QB-144GJ-HQ-01T QB-176GM-HQ-01T Mount adapter</p>	<p>Adapter to mount the V850E/SJ3-H or V850E/SK3-H on a socket.</p> <ul style="list-style-type: none"> <li>• QB-144GJ-MA-01S: 144-pin plastic LQFP (GJ-GAE type)</li> <li>• QB-176GM-MA-01S: 176-pin plastic LQFP (GM-GAR type)</li> <li>• QB-144GJ-HQ-01T: 144-pin plastic LQFP (GJ-GAE type)</li> <li>• QB-176GM-HQ-01T: 176-pin plastic LQFP (GM-GAR type)</li> </ul>
<p>&lt;14&gt; QB-144GJ-TC-01S QB-176GM-TC-01S QB-144GJ-NQ-01T QB-176GM-NQ-01T Target connector</p>	<p>Connector to solder on the target system.</p> <ul style="list-style-type: none"> <li>• QB-144GJ-TC-01S: 144-pin plastic LQFP (GJ-GAE type)</li> <li>• QB-176GM-TC-01S: 176-pin plastic LQFP (GM-GAR type)</li> <li>• QB-144GJ-NQ-01T: 144-pin plastic LQFP (GJ-GAE type)</li> <li>• QB-176GM-NQ-01T: 176-pin plastic LQFP (GM-GAR type)</li> </ul>

**Note** The QB-V850ESX3H is supplied with a power supply unit, USB interface cable, and flash memory programmer (MINICUBE2). It is also supplied with integrated debugger ID850QB as control software.

**Remark** The numbers in the angle brackets correspond to the numbers in Figure A-2.

**A.4.2 When using on-chip debug emulator IE-V850E1-CD-NW**

The system configuration when connecting the IE-V850E1-CD-NW to the host machine (PC-9821 series, PC/AT compatible) is shown below.

**Figure A-3. System Configuration (IE-V850E1-CD-NW Used)**

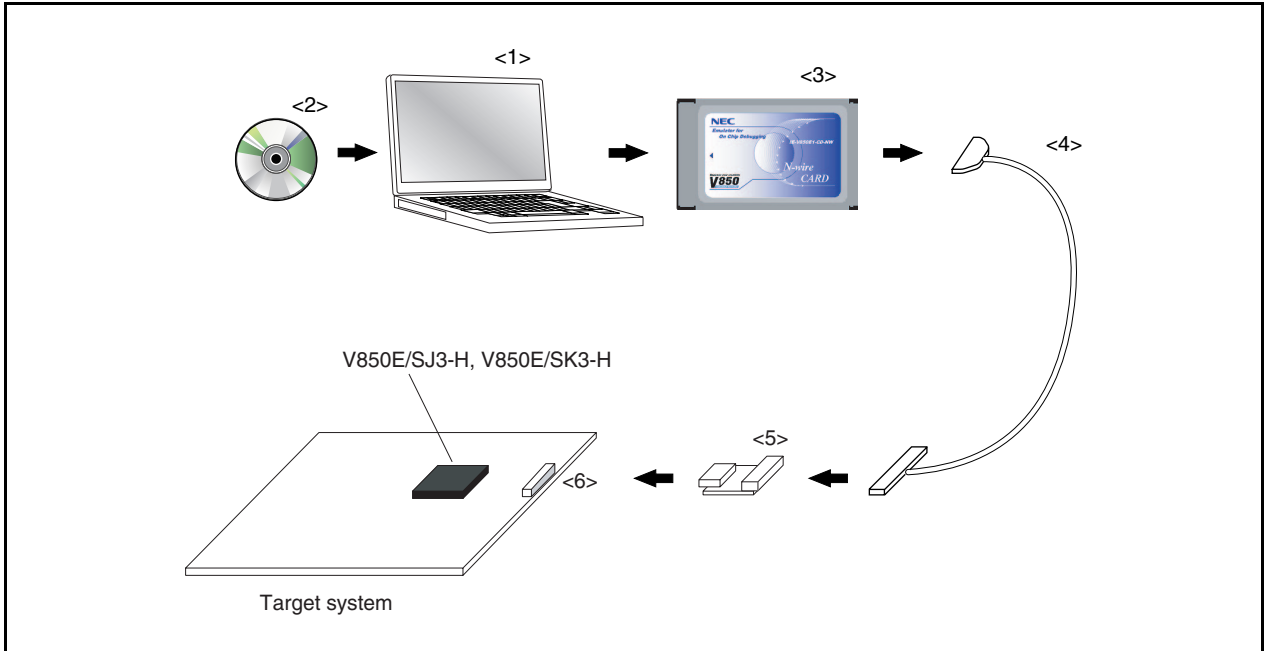

<1> Host machine	Personal computer including PCMCIA compliant with the PCMCIA2.1/JEIDA standard Ver. 4.2. When using a product which does not have a PCMCIA slot, use a PCI-PCMCIA conversion board or the like. For details on the conversion board, consult an NEC Electronics sales representative.
<2> CD-ROM <sup>Note 1</sup>	The integrated debugger ID850QB, N-Wire Checker, device driver, documents and so on in the CD-ROM format are included. This CD-ROM is supplied with the IE-V850E1-CD-NW.
<3> IE-V850E1-CD-NW On-chip debug emulator	This on-chip debug emulator is used to debug hardware and software when application systems using the V850E/SJ3-H or V850E/SK3-H are developed. It is supplied with the integrated debugger ID850QB.
<4> IE-V850E1-CD-NW connection cable	This connection cable is used to connect the IE-V850E1-CD-NW and the target system. It is supplied with the IE-V850E1-CD-NW. The cable length is approximately 50 cm.
<5> Connector conversion board KEL adapter	It is supplied with the IE-V850E1-CD-NW.
<6> IE-V850E1-CD-NW connector KEL connector <sup>Note 2</sup>	8830E-026-170S (It is supplied with the IE-V850E1-CD-NW.) 8830E-026-170L (sold separately)

**Notes 1.** Obtain the device file from the NEC Electronics website.

<http://www.necel.com/micro/en/ods/index.html>

**2.** Product of KEL Corporation

**Remark** The numbers in the square brackets correspond to the numbers in Figure A-3.

### A.4.3 When using MINICUBE QB-V850MINI

The system configuration when connecting the QB-V850MINI to the host machine (PC-9821 series, PC/AT compatible) is shown below.

Figure A-4. System Configuration (QB-V850MINI Used)

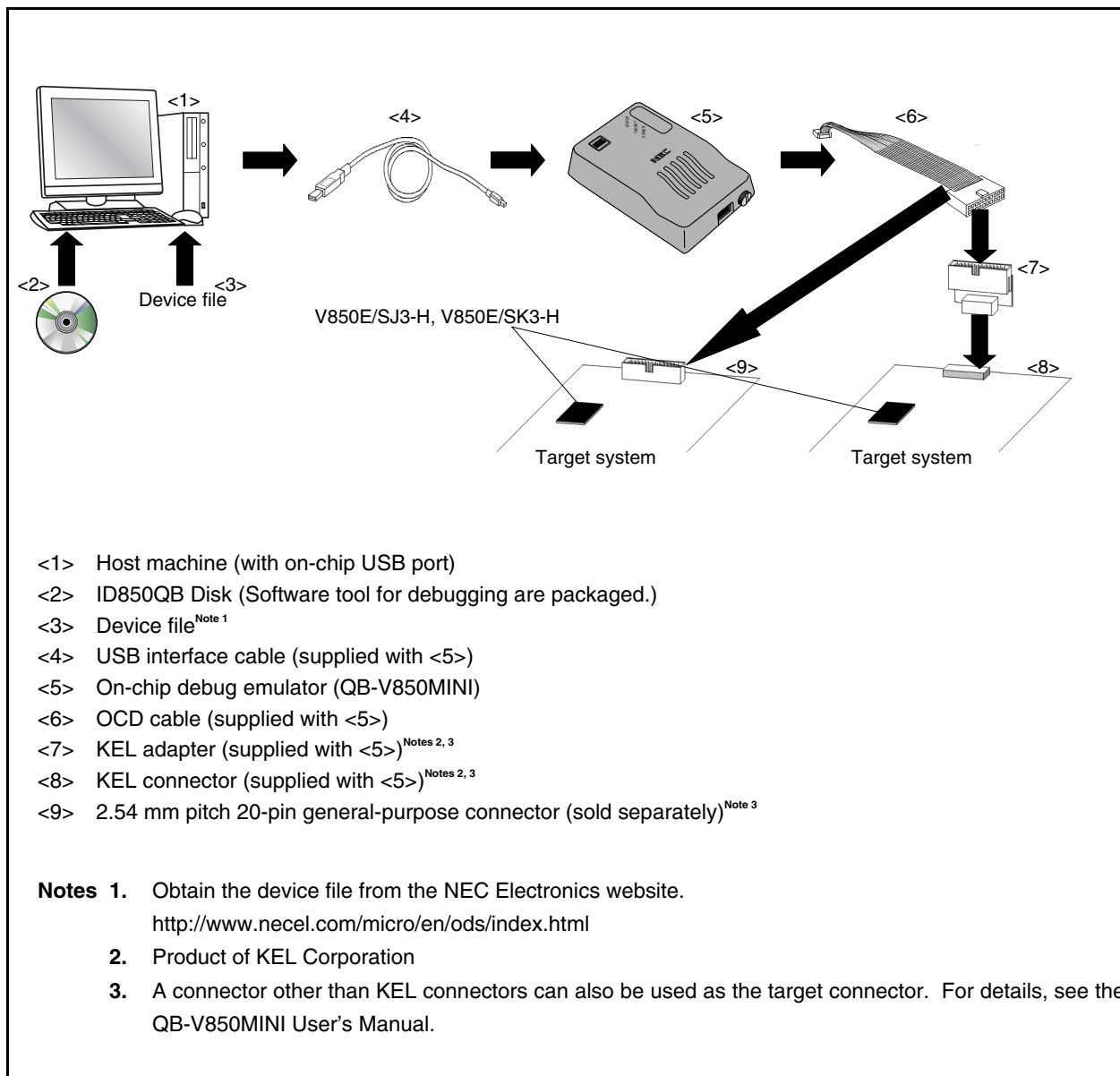



<R>

**A.4.4 When using MINICUBE2 QB-MINI2**

The system configuration when connecting MINICUBE2 to the host machine (PC-9821 series, PC/AT compatible) is shown below.

**Figure A-5. System Configuration of On-Chip Emulation System**

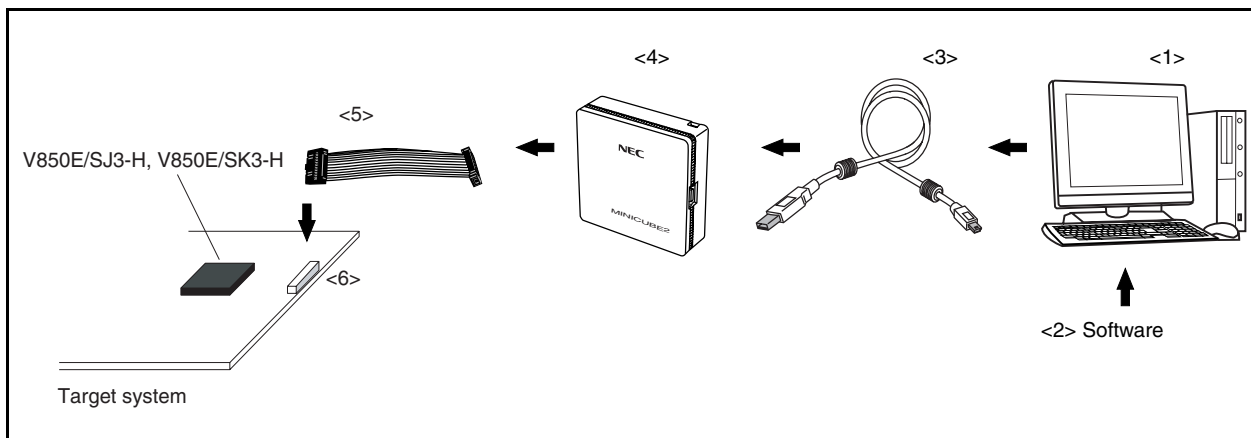

<1> Host machine	PC with USB ports
<2> Software	The integrated debugger ID850QB, device file, etc. Download the device file from the NEC Electronics website. <a href="http://www.necel.com/micro/en/ods/index.html">http://www.necel.com/micro/en/ods/index.html</a>
<3> USB interface cable	USB cable to connect the host machine and MINICUBE2. It is supplied with MINICUBE2. The cable length is approximately 2 m.
<4> MINICUBE2 On-chip debug emulator	This on-chip debug emulator serves to debug hardware and software when developing application systems using the V850E/SJ3-H or V850E/SK3-H. It supports integrated debugger ID850QB.
<5> 16-pin target cable	Cable to connect MINICUBE2 and the target system. It is supplied with MINICUBE2. The cable length is approximately 15 cm.
<6> Target connector (sold separately)	Use a 16-pin general-purpose connector with 2.54 mm pitch.

**Remark** The numbers in the angular brackets correspond to the numbers in Figure A-5.

### A.5 Debugging Tools (Software)

ID850QB Integrated debugger	This debugger supports the in-circuit emulators for the V850 microcontrollers. The ID850QB is a Windows-based software. It has improved C-compatible debugging functions and can display the results of tracing with the source program using an integrating window function that associates the source program, disassemble display, and memory display with the trace result. It should be used in combination with the device file (sold separately).
Part number: $\mu$ SxxxxID703000-QB (ID850QB)	

**Remark** xxxx in the part number differs depending on the OS used.

$\mu$ SxxxxID703000-QB

xxxx	Host Machine	OS	Supply Medium
AB17	PC-9800 series,	Windows (Japanese version)	CD-ROM
BB17	IBM PC/AT compatibles	Windows (English version)	

## A.6 Embedded Software

RX850, RX850 Pro Real-time OS	The RX850 and RX850 Pro are real-time OSs conforming to $\mu$ ITRON 3.0 specifications. A tool (configurator) for generating multiple information tables is supplied. RX850 Pro has more functions than RX850.
	Part number: $\mu$ SxxxxRX703000- $\Delta\Delta\Delta\Delta$ (RX850) $\mu$ SxxxxRX703100- $\Delta\Delta\Delta\Delta$ (RX850 Pro)
V850mini-NET (provisional name) (Network library)	This is a network library conforming to RFC. It is a lightweight TCP/IP of compact design, requiring only a small memory. In addition to the TCP/IP standard set, an HTTP server, SMTP client, and POP client are also supported.
RX-FS850 (File system)	This is a FAT file system function. It is a file system that supports the CD-ROM file system function. This file system is used with the real-time OS RX850 Pro.

**Caution** To purchase the RX850 or RX850 Pro, first fill in the purchase application form and sign the user agreement.

**Remark** xxxx and  $\Delta\Delta\Delta\Delta$  in the part number differ depending on the host machine and OS used.

$\mu$ SxxxxRX703000- $\Delta\Delta\Delta\Delta$

$\mu$ SxxxxRX703100- $\Delta\Delta\Delta\Delta$

$\Delta\Delta\Delta\Delta$	Product Outline	Maximum Number for Use in Mass Production
001	Evaluation object	Do not use for mass-produced product.
100K	Mass-production object	0.1 million units
001M		1 million units
010M		10 million units
S01	Source program	Object source program for mass production

xxxx	Host Machine	OS	Supply Medium
AB17	PC-9800 series, IBM PC/AT compatibles	Windows (Japanese version)	CD-ROM
BB17		Windows (English version)	
3K17	SPARCstation	Solaris (Rel. 2.5.1)	

## A.7 Flash Memory Writing Tools

<R>	Flashpro V (part number: PG-FP5) Flash memory programmer	Flash memory programmer dedicated to microcontrollers with on-chip flash memory.
<R>	FA-144GJ-GAE-B Flash memory writing adapter	Flash memory writing adapter used connected to Flashpro V. • FA-144GJ-GAE-B: For 144-pin plastic LQFP (GJ-GAE type)
<R>	FA-176GM-GAR-B Flash memory writing adapter	Flash memory writing adapter used connected to Flashpro V. • FA-176GM-GAR-B: For 176-pin plastic LQFP (GM-GAR type)

**Remark** FA-144GJ-GAE-B and FA-176GM-GAR-B are products of Naito Densai Machida Mfg. Co., Ltd.  
TEL: +81-42-750-4172 Naito Densai Machida Mfg. Co., Ltd.

## APPENDIX B REGISTER INDEX

(1/20)

Symbol	Name	Unit	Page
ADA0CR0	A/D conversion result register 0	ADC	686
ADA0CR0H	A/D conversion result register 0H	ADC	686
ADA0CR1	A/D conversion result register 1	ADC	686
ADA0CR1H	A/D conversion result register 1H	ADC	686
ADA0CR2	A/D conversion result register 2	ADC	686
ADA0CR2H	A/D conversion result register 2H	ADC	686
ADA0CR3	A/D conversion result register 3	ADC	686
ADA0CR3H	A/D conversion result register 3H	ADC	686
ADA0CR4	A/D conversion result register 4	ADC	686
ADA0CR4H	A/D conversion result register 4H	ADC	686
ADA0CR5	A/D conversion result register 5	ADC	686
ADA0CR5H	A/D conversion result register 5H	ADC	686
ADA0CR6	A/D conversion result register 6	ADC	686
ADA0CR6H	A/D conversion result register 6H	ADC	686
ADA0CR7	A/D conversion result register 7	ADC	686
ADA0CR7H	A/D conversion result register 7H	ADC	686
ADA0CR8	A/D conversion result register 8	ADC	686
ADA0CR8H	A/D conversion result register 8H	ADC	686
ADA0CR9	A/D conversion result register 9	ADC	686
ADA0CR9H	A/D conversion result register 9H	ADC	686
ADA0CR10	A/D conversion result register 10	ADC	686
ADA0CR10H	A/D conversion result register 10H	ADC	686
ADA0CR11	A/D conversion result register 11	ADC	686
ADA0CR11H	A/D conversion result register 11H	ADC	686
ADA0CR12	A/D conversion result register 12	ADC	686
ADA0CR12H	A/D conversion result register 12H	ADC	686
ADA0CR13	A/D conversion result register 13	ADC	686
ADA0CR13H	A/D conversion result register 13H	ADC	686
ADA0CR14	A/D conversion result register 14	ADC	686
ADA0CR14H	A/D conversion result register 14H	ADC	686
ADA0CR15	A/D conversion result register 15	ADC	686
ADA0CR15H	A/D conversion result register 15H	ADC	686
ADA0M0	A/D converter mode register 0	ADC	679
ADA0M1	A/D converter mode register 1	ADC	681
ADA0M2	A/D converter mode register 2	ADC	684
ADA0PFM	Power-fail compare mode register	ADC	688
ADA0PFT	Power-fail compare threshold value register	ADC	689
ADA0S	A/D converter channel specification register	ADC	685
ADIC	Interrupt control register	INTC	1296

Symbol	Name	Unit	Page
ASID	Program ID register	CPU	83
AWC	Address wait control register	BCU	316
BCC	Bus cycle control register	BCU	318
BCR	IEBus control register	IEBus	1032
BPC	Peripheral I/O area select control register	CPU	123
BSC	Bus size configuration register	BCU	303
C0BRP	CAN0 module bit rate prescaler register	CAN	1167
C0BTR	CAN0 module bit rate register	CAN	1168
C0CTRL	CAN0 module control register	CAN	1157
C0ERC	CAN0 module error counter register	CAN	1163
C0GMABT	CAN0 global automatic block transmission control register	CAN	1152
C0GMABTD	CAN0 global automatic block transmission delay register	CAN	1154
C0GMCS	CAN0 global clock selection register	CAN	1151
C0GMCTRL	CAN0 global control register	CAN	1149
C0IE	CAN0 module interrupt enable register	CAN	1164
C0INFO	CAN0 module information register	CAN	1162
C0INTS	CAN0 module interrupt status register	CAN	1166
C0LEC	CAN0 module last error information register	CAN	1161
C0LIPT	CAN0 module last in-pointer register	CAN	1170
C0LOPT	CAN0 module last out-pointer register	CAN	1172
C0MASK1H	CAN0 module mask 1 register H	CAN	1155
C0MASK1L	CAN0 module mask 1 register L	CAN	1155
C0MASK2H	CAN0 module mask 2 register H	CAN	1155
C0MASK2L	CAN0 module mask 2 register L	CAN	1155
C0MASK3H	CAN0 module mask 3 register H	CAN	1155
C0MASK3L	CAN0 module mask 3 register L	CAN	1155
C0MASK4H	CAN0 module mask 4 register H	CAN	1155
C0MASK4L	CAN0 module mask 4 register L	CAN	1155
C0MCONFm	CAN0 message configuration register m	CAN	1179
C0MCTRLm	CAN0 message control register m	CAN	1181
C0MDATA01m	CAN0 message data byte 01 register m	CAN	1176
C0MDATA0m	CAN0 message data byte 0 register m	CAN	1176
C0MDATA1m	CAN0 message data byte 1 register m	CAN	1176
C0MDATA23m	CAN0 message data byte 23 register m	CAN	1176
C0MDATA2m	CAN0 message data byte 2 register m	CAN	1176
C0MDATA3m	CAN0 message data byte 3 register m	CAN	1176
C0MDATA45m	CAN0 message data byte 45 register m	CAN	1176
C0MDATA4m	CAN0 message data byte 4 register m	CAN	1176
C0MDATA5m	CAN0 message data byte 5 register m	CAN	1176
C0MDATA67m	CAN0 message data byte 67 register m	CAN	1176
C0MDATA6m	CAN0 message data byte 6 register m	CAN	1176
C0MDATA7m	CAN0 message data byte 7 register m	CAN	1176
C0MDLc	CAN0 message data length register m	CAN	1178

**Remark** m = 00 to 31

Symbol	Name	Unit	Page
C0MIDHm	CAN0 message ID register mH	CAN	1180
C0MIDLm	CAN0 message ID register mL	CAN	1180
C0RGPT	CAN0 module receive history list register	CAN	1171
C0TGPT	CAN0 module transmit history list register	CAN	1173
C0TS	CAN0 module time stamp register	CAN	1174
C1BRP	CAN1 module bit rate prescaler register	CAN	1167
C1BTR	CAN1 module bit rate register	CAN	1168
C1CTRL	CAN1 module control register	CAN	1157
C1ERC	CAN1 module error counter register	CAN	1163
C1GMABT	CAN1 global automatic block transmission control register	CAN	1152
C1GMABTD	CAN1 global automatic block transmission delay register	CAN	1154
C1GMCS	CAN1 global clock selection register	CAN	1151
C1GMCTRL	CAN1 global control register	CAN	1149
C1IE	CAN1 module interrupt enable register	CAN	1164
C1INFO	CAN1 module information register	CAN	1162
C1INTS	CAN1 module interrupt status register	CAN	1166
C1LEC	CAN1 module last error information register	CAN	1161
C1LIPT	CAN1 module last in-pointer register	CAN	1170
C1LOPT	CAN1 module last out-pointer register	CAN	1172
C1MASK1H	CAN1 module mask 1 register H	CAN	1155
C1MASK1L	CAN1 module mask 1 register L	CAN	1155
C1MASK2H	CAN1 module mask 2 register H	CAN	1155
C1MASK2L	CAN1 module mask 2 register L	CAN	1155
C1MASK3H	CAN1 module mask 3 register H	CAN	1155
C1MASK3L	CAN1 module mask 3 register L	CAN	1155
C1MASK4H	CAN1 module mask 4 register H	CAN	1155
C1MASK4L	CAN1 module mask 4 register L	CAN	1155
C1MCONFm	CAN1 message configuration register m	CAN	1179
C1MCTRLm	CAN1 message control register m	CAN	1181
C1MDATA01m	CAN1 message data byte 01 register m	CAN	1176
C1MDATA0m	CAN1 message data byte 0 register m	CAN	1176
C1MDATA1m	CAN1 message data byte 1 register m	CAN	1176
C1MDATA23m	CAN1 message data byte 23 register m	CAN	1176
C1MDATA2m	CAN1 message data byte 2 register m	CAN	1176
C1MDATA3m	CAN1 message data byte 3 register m	CAN	1176
C1MDATA45m	CAN1 message data byte 45 register m	CAN	1176
C1MDATA4m	CAN1 message data byte 4 register m	CAN	1176
C1MDATA5m	CAN1 message data byte 5 register m	CAN	1176
C1MDATA67m	CAN1 message data byte 67 register m	CAN	1176
C1MDATA6m	CAN1 message data byte 6 register m	CAN	1176
C1MDATA7m	CAN1 message data byte 7 register m	CAN	1176
C1MDLCm	CAN1 message data length register m	CAN	1178
C1MIDHm	CAN1 message ID register mH	CAN	1180
C1MIDLm	CAN1 message ID register mL	CAN	1180

**Remark** m = 00 to 31

Symbol	Name	Unit	Page
C1RGPT	CAN1 module receive history list register	CAN	1171
C1TGPT	CAN1 module transmit history list register	CAN	1173
C1TS	CAN1 module time stamp register	CAN	1174
CB0CTL0	CSIB0 control register 0	CSI	828
CB0CTL1	CSIB0 control register 1	CSI	831
CB0CTL2	CSIB0 control register 2	CSI	833
CB0RIC	Interrupt control register	INTC	1296
CB0RX	CSIB0 receive data register	CSI	827
CB0RXL	CSIB0 receive data register L	CSI	827
CB0STR	CSIB0 status register	CSI	835
CB0TIC	Interrupt control register	INTC	1296
CB0TX	CSIB0 transmit data register	CSI	827
CB0TXL	CSIB0 transmit data register L	CSI	827
CB1CTL0	CSIB1 control register 0	CSI	828
CB1CTL1	CSIB1 control register 1	CSI	831
CB1CTL2	CSIB1 control register 2	CSI	833
CB1RIC	Interrupt control register	INTC	1296
CB1RX	CSIB1 receive data register	CSI	827
CB1RXL	CSIB1 receive data register L	CSI	827
CB1STR	CSIB1 status register	CSI	835
CB1TIC	Interrupt control register	INTC	1296
CB1TX	CSIB1 transmit data register	CSI	827
CB1TXL	CSIB1 transmit data register L	CSI	827
CB2CTL0	CSIB2 control register 0	CSI	828
CB2CTL1	CSIB2 control register 1	CSI	831
CB2CTL2	CSIB2 control register 2	CSI	833
CB2RIC	Interrupt control register	INTC	1296
CB2RX	CSIB2 receive data register	CSI	827
CB2RXL	CSIB2 receive data register L	CSI	827
CB2STR	CSIB2 status register	CSI	835
CB2TIC	Interrupt control register	INTC	1296
CB2TX	CSIB2 transmit data register	CSI	827
CB2TXL	CSIB2 transmit data register L	CSI	827
CB3CTL0	CSIB3 control register 0	CSI	828
CB3CTL1	CSIB3 control register 1	CSI	831
CB3CTL2	CSIB3 control register 2	CSI	833
CB3RIC	Interrupt control register	INTC	1296
CB3RX	CSIB3 receive data register	CSI	827
CB3RXL	CSIB3 receive data register L	CSI	827
CB3STR	CSIB3 status register	CSI	835
CB3TIC	Interrupt control register	INTC	1296
CB3TX	CSIB3 transmit data register	CSI	827
CB3TXL	CSIB3 transmit data register L	CSI	827
CB4CTL0	CSIB4 control register 0	CSI	828



Symbol	Name	Unit	Page
CB4CTL1	CSIB4 control register 1	CSI	831
CB4CTL2	CSIB4 control register 2	CSI	833
CB4RIC	Interrupt control register	INTC	1296
CB4RX	CSIB4 receive data register	CSI	827
CB4RXL	CSIB4 receive data register L	CSI	827
CB4STR	CSIB4 status register	CSI	835
CB4TIC	Interrupt control register	INTC	1296
CB4TX	CSIB4 transmit data register	CSI	827
CB4TXL	CSIB4 transmit data register L	CSI	827
CB5CTL0	CSIB5 control register 0	CSI	828
CB5CTL1	CSIB5 control register 1	CSI	831
CB5CTL2	CSIB5 control register 2	CSI	833
CB5RIC	Interrupt control register	INTC	1296
CB5RX	CSIB5 receive data register	CSI	827
CB5RXL	CSIB5 receive data register L	CSI	827
CB5STR	CSIB5 status register	CSI	835
CB5TIC	Interrupt control register	INTC	1296
CB5TX	CSIB5 transmit data register	CSI	827
CB5TXL	CSIB5 transmit data register L	CSI	827
CCLS	CPU operation clock status register	CG	347
CCR	IEBus communication count register	IEBus	1059
CDR	IEBus control data register	IEBus	1050
CE0CTL0	CSIE0 control register 0	CSIE	828
CE0CTL1	CSIE0 control register 1	CSIE	831
CE0CTL2	CSIE0 control register 2	CSIE	833
CE0CTL3	CSIE0 control register 3	CSIE	834
CE0RX0	CSIE0 receive data buffer register	CSIE	883
CE0RX0H	CSIE0 receive data buffer register H	CSIE	883
CE0RX0L	CSIE0 receive data buffer register L	CSIE	883
CE0STR	CSIE0 status register	CSIE	892
CE0TIC	Interrupt control register	INTC	1296
CE0TIOFIC	Interrupt control register	INTC	1296
CE0TX0	CSIE0 transmit data buffer register	CSIE	884
CE0TX0H	CSIE0 transmit data buffer register H	CSIE	884
CE0TX0L	CSIE0 transmit data buffer register L	CSIE	884
CE1CTL0	CSIE1 control register 0	CSIE	828
CE1CTL1	CSIE1 control register 1	CSIE	831
CE1CTL2	CSIE1 control register 2	CSIE	833
CE1CTL3	CSIE1 control register 3	CSIE	834
CE1RX0	CSIE1 receive data buffer register	CSIE	883
CE1RX0H	CSIE1 receive data buffer register H	CSIE	883
CE1RX0L	CSIE1 receive data buffer register L	CSIE	883
CE1STR	CSIE1 status register	CSIE	892
CE1TIC	Interrupt control register	INTC	1296

Symbol	Name	Unit	Page
CE1TIOFIC	Interrupt control register	INTC	1296
CE1TX0	CSIE1 transmit data buffer register	CSIE	884
CE1TX0H	CSIE1 transmit data buffer register H	CSIE	884
CE1TX0L	CSIE1 transmit data buffer register L	CSIE	884
CKC	Clock control register	CG	349
CLM	Clock monitor mode register	CLM	1371
CORAD0	Correction address register 0	ROMC	1385
CORAD0H	Correction address register 0H	ROMC	1385
CORAD0L	Correction address register 0L	ROMC	1385
CORAD1	Correction address register 1	ROMC	1385
CORAD1H	Correction address register 1H	ROMC	1385
CORAD1L	Correction address register 1L	ROMC	1385
CORAD2	Correction address register 2	ROMC	1385
CORAD2H	Correction address register 2H	ROMC	1385
CORAD2L	Correction address register 2L	ROMC	1385
CORAD3	Correction address register 3	ROMC	1385
CORAD3H	Correction address register 3H	ROMC	1385
CORAD3L	Correction address register 3L	ROMC	1385
CORAD4	Correction address register 4	ROMC	1385
CORAD4H	Correction address register 4H	ROMC	1385
CORAD4L	Correction address register 4L	ROMC	1385
CORAD5	Correction address register 5	ROMC	1385
CORAD5H	Correction address register 5H	ROMC	1385
CORAD5L	Correction address register 5L	ROMC	1385
CORAD6	Correction address register 6	ROMC	1385
CORAD6H	Correction address register 6H	ROMC	1385
CORAD6L	Correction address register 6L	ROMC	1385
CORAD7	Correction address register 7	ROMC	1385
CORAD7H	Correction address register 7H	ROMC	1385
CORAD7L	Correction address register 7L	ROMC	1385
CORCN	Correction control register	ROMC	1387
CRCD	CRC data register	CRC	1274
CRCIN	CRC input register	CRC	1274
CSC0	Chip area select control register 0	BCU	296
CSC1	Chip area select control register 1	BCU	296
CTBP	CALLT base pointer	CPU	82
CTPC	CALLT execution status saving register	CPU	81
CTPSW	CALLT execution status saving register	CPU	81
DA0CS0	D/A converter conversion value setting register 0	DAC	714
DA0CS1	D/A converter conversion value setting register 1	DAC	714
DA0M	D/A converter mode register	DAC	713
DADC0	DMA addressing control register 0	DMA	1255
DADC1	DMA addressing control register 1	DMA	1255
DADC2	DMA addressing control register 2	DMA	1255
DADC3	DMA addressing control register 3	DMA	1255

Symbol	Name	Unit	Page
DBC0	DMA transfer count register 0	DMA	1254
DBC1	DMA transfer count register 1	DMA	1254
DBC2	DMA transfer count register 2	DMA	1254
DBC3	DMA transfer count register 3	DMA	1254
DBPC	Exception/debug trap status saving register	CPU	82
DBPSW	Exception/debug trap status saving register	CPU	82
DCHC0	DMA channel control register 0	DMA	1256
DCHC1	DMA channel control register 1	DMA	1256
DCHC2	DMA channel control register 2	DMA	1256
DCHC3	DMA channel control register 3	DMA	1256
DDA0H	DMA destination address register 0H	DMA	1253
DDA0L	DMA destination address register 0L	DMA	1253
DDA1H	DMA destination address register 1H	DMA	1253
DDA1L	DMA destination address register 1L	DMA	1253
DDA2H	DMA destination address register 2H	DMA	1253
DDA2L	DMA destination address register 2L	DMA	1253
DDA3H	DMA destination address register 3H	DMA	1253
DDA3L	DMA destination address register 3L	DMA	1253
DLR	IEBus telegraph length register	IEBus	1055
DMAIC0	Interrupt control register	INTC	1296
DMAIC1	Interrupt control register	INTC	1296
DMAIC2	Interrupt control register	INTC	1296
DMAIC3	Interrupt control register	INTC	1296
DR	IEBus data register	IEBus	1056
DSA0H	DMA source address register 0H	DMA	1252
DSA0L	DMA source address register 0L	DMA	1252
DSA1H	DMA source address register 1H	DMA	1252
DSA1L	DMA source address register 1L	DMA	1252
DSA2H	DMA source address register 2H	DMA	1252
DSA2L	DMA source address register 2L	DMA	1252
DSA3H	DMA source address register 3H	DMA	1252
DSA3L	DMA source address register 3L	DMA	1252
DTFR0	DMA trigger factor register 0	DMA	1257
DTFR1	DMA trigger factor register 1	DMA	1257
DTFR2	DMA trigger factor register 2	DMA	1257
DTFR3	DMA trigger factor register 3	DMA	1257
DWC0	Data wait control register 0	BCU	311
DWC1	Data wait control register 1	BCU	312
ECR	Interrupt source register	CPU	79
EIPC	Interrupt status saving register	CPU	78
EIPSW	Interrupt status saving register	CPU	78
ENONFC	TMP7 noise elimination control register	Timer	392
EN1NFC	TMP8 noise elimination control register	Timer	392
ERRIC	Interrupt control register	INTC	1296

Symbol	Name	Unit	Page
ERRIC0	Interrupt control register	INTC	1296
ERRIC1	Interrupt control register	INTC	1296
ESR	IEBus error status register	IEBus	1044
EXIMC	External bus interface mode control register	BCU	301
FEPC	NMI status saving register	CPU	79
FEPSW	NMI status saving register	CPU	79
FSR	IEBus field status register	IEBus	1057
IEIC1	Interrupt control register	INTC	1296
IEIC2	Interrupt control register	INTC	1296
IIC0	IIC shift register 0	I <sup>2</sup> C	953
IIC1	IIC shift register 1	I <sup>2</sup> C	953
IIC2	IIC shift register 2	I <sup>2</sup> C	953
IIC3	IIC shift register 3	I <sup>2</sup> C	953
IIC4	IIC shift register 4	I <sup>2</sup> C	953
IIC5	IIC shift register 5	I <sup>2</sup> C	953
IICC0	IIC control register 0	I <sup>2</sup> C	936
IICC1	IIC control register 1	I <sup>2</sup> C	936
IICC2	IIC control register 2	I <sup>2</sup> C	936
IICC3	IIC control register 3	I <sup>2</sup> C	936
IICC4	IIC control register 4	I <sup>2</sup> C	936
IICC5	IIC control register 5	I <sup>2</sup> C	936
IICCL0	IIC clock select register 0	I <sup>2</sup> C	946
IICCL1	IIC clock select register 1	I <sup>2</sup> C	946
IICCL2	IIC clock select register 2	I <sup>2</sup> C	946
IICCL3	IIC clock select register 3	I <sup>2</sup> C	946
IICCL4	IIC clock select register 4	I <sup>2</sup> C	946
IICCL5	IIC clock select register 5	I <sup>2</sup> C	946
IICF0	IIC flag register 0	I <sup>2</sup> C	944
IICF1	IIC flag register 1	I <sup>2</sup> C	944
IICF2	IIC flag register 2	I <sup>2</sup> C	944
IICF3	IIC flag register 3	I <sup>2</sup> C	944
IICF4	IIC flag register 4	I <sup>2</sup> C	944
IICF5	IIC flag register 5	I <sup>2</sup> C	944
IICIC0	Interrupt control register	INTC	1296
IICIC1	Interrupt control register	INTC	1296
IICIC2	Interrupt control register	INTC	1296
IICIC3	Interrupt control register	INTC	1296
IICIC4	Interrupt control register	INTC	1296
IICIC5	Interrupt control register	INTC	1296
IICS0	IIC status register 0	I <sup>2</sup> C	941
IICS1	IIC status register 1	I <sup>2</sup> C	941
IICS2	IIC status register 2	I <sup>2</sup> C	941
IICS3	IIC status register 3	I <sup>2</sup> C	941
IICS4	IIC status register 4	I <sup>2</sup> C	941

Symbol	Name	Unit	Page
IICS5	IIC status register 5	I <sup>2</sup> C	941
IICX0	IIC function expansion register 0	I <sup>2</sup> C	947
IICX1	IIC function expansion register 1	I <sup>2</sup> C	947
IICX2	IIC function expansion register 2	I <sup>2</sup> C	947
IICX3	IIC function expansion register 3	I <sup>2</sup> C	947
IICX4	IIC function expansion register 4	I <sup>2</sup> C	947
IICX5	IIC function expansion register 5	I <sup>2</sup> C	947
IMR0	Interrupt mask register 0	INTC	1300
IMR0H	Interrupt mask register 0H	INTC	1300
IMR0L	Interrupt mask register 0L	INTC	1300
IMR1	Interrupt mask register 1	INTC	1300
IMR1H	Interrupt mask register 1H	INTC	1300
IMR1L	Interrupt mask register 1L	INTC	1300
IMR2	Interrupt mask register 2	INTC	1300
IMR2H	Interrupt mask register 2H	INTC	1300
IMR2L	Interrupt mask register 2L	INTC	1300
IMR3	Interrupt mask register 3	INTC	1300
IMR3H	Interrupt mask register 3H	INTC	1300
IMR3L	Interrupt mask register 3L	INTC	1300
IMR4	Interrupt mask register 4	INTC	1300
IMR4H	Interrupt mask register 4H	INTC	1300
IMR4L	Interrupt mask register 4L	INTC	1300
IMR5	Interrupt mask register 5	INTC	1300
IMR5H	Interrupt mask register 5H	INTC	1300
IMR5L	Interrupt mask register 5L	INTC	1300
IMR6	Interrupt mask register 6	INTC	1300
IMR6H	Interrupt mask register 6H	INTC	1300
IMR6L	Interrupt mask register 6L	INTC	1300
IMR7L	Interrupt mask register 7L	INTC	1300
INTF0	External falling edge specification register 0	INTC	1314
INTF3	External falling edge specification register 3	INTC	1315
INTF4	External falling edge specification register 4	INTC	1316
INTF5	External falling edge specification register 5	INTC	1317
INTF6	External falling edge specification register 6	INTC	1318
INTF8	External falling edge specification register 8	INTC	1319
INTF9	External falling edge specification register 9	INTC	1320
INTF9H	External falling edge specification register 9H	INTC	1320
INTF9L	External falling edge specification register 9L	INTC	1320
INTF15	External falling edge specification register 15	INTC	1321
INTR0	External rising edge specification register 0	INTC	1314
INTR3	External rising edge specification register 3	INTC	1315
INTR4	External rising edge specification register 4	INTC	1316
INTR5	External rising edge specification register 5	INTC	1317
INTR6	External rising edge specification register 6	INTC	1318

Symbol	Name	Unit	Page
INTR8	External rising edge specification register 8	INTC	1319
INTR9	External rising edge specification register 9	INTC	1320
INTR9H	External rising edge specification register 9H	INTC	1320
INTR9L	External rising edge specification register 9L	INTC	1320
INTR15	External rising edge specification register 15	INTC	1321
ISPR	In-service priority register	INTC	1303
ISR	IEBus interrupt status register	IEBus	1041
KRIC	Interrupt control register	INTC	1296
KRM	Key return mode register	KR	1327
LOCKR	Lock register	CG	350
LVIIC	Interrupt control register	INTC	1296
LVIM	Low voltage detection register	LVI	1376
LVIS	Low voltage detection level select register	LVI	1377
NFC	Noise elimination control register	INTC	1322
OCDM	On-chip debug mode register	DCU	1429
OCKS0	IIC division clock select register 0	I <sup>2</sup> C	952
OCKS1	IIC division clock select register 1	I <sup>2</sup> C	952
OCKS2	IEBus clock select register	IEBus	1060
OCKS3	IIC division clock select register 3	I <sup>2</sup> C	952
OSTS	Oscillation stabilization time select register	WDT	1332
P0	Port 0 register	Port	141
P1	Port 1 register	Port	145
P2	Port 2 register	Port	146
P3	Port 3 register	Port	149
P3H	Port 3 register H	Port	149
P3L	Port 3 register L	Port	149
P4	Port 4 register	Port	158
P5	Port 5 register	Port	162
P6	Port 6 register	Port	168
P6H	Port 6 register H	Port	168
P6L	Port 6 register L	Port	168
P7H	Port 7 register H	Port	176
P7L	Port 7 register L	Port	176
P8	Port 8 register	Port	177
P9	Port 9 register	Port	183
P9H	Port 9 register H	Port	183
P9L	Port 9 register L	Port	183
P13	Port 13 register	Port	190
P14	Port 14 register	Port	191
P15	Port 15 register	Port	192
PAR	IEBus partner address register	IEBus	1049
PC	Program counter	CPU	76
PCC	Processor clock control register	CG	345
PCD	Port CD register	Port	194

Symbol	Name	Unit	Page
PCM	Port CM register	Port	196
PCS	Port CS register	Port	198
PCT	Port CT register	Port	200
PDH	Port DH register	Port	202
PDL	Port DL register	Port	205
PDLH	Port DL register H	Port	205
PDLL	Port DL register L	Port	205
PEMU1	Peripheral emulation register 1	CPU	1381
PF0	Port 0 function register	Port	144
PF2	Port 2 function register	Port	147
PF3	Port 3 function register	Port	156
PF3H	Port 3 function register H	Port	156
PF3L	Port 3 function register L	Port	156
PF4	Port 4 function register	Port	160
PF5	Port 5 function register	Port	166
PF6	Port 6 function register	Port	174
PF6H	Port 6 function register H	Port	174
PF6L	Port 6 function register L	Port	174
PF8	Port 8 function register	Port	181
PF9	Port 9 function register	Port	189
PF9H	Port 9 function register H	Port	189
PF9L	Port 9 function register L	Port	189
PF15	Port 15 function register	Port	193
PFC0	Port 0 function control register	Port	143
PFC3	Port 3 function control register	Port	153
PFC3H	Port 3 function control register H	Port	153
PFC3L	Port 3 function control register L	Port	153
PFC4	Port 4 function control register	Port	160
PFC5	Port 5 function control register	Port	164
PFC6	Port 6 function control register	Port	171
PFC6H	Port 6 function control register H	Port	171
PFC6L	Port 6 function control register L	Port	171
PFC8	Port 8 function control register	Port	180
PFC9	Port 9 function control register	Port	186
PFC9H	Port 9 function control register H	Port	186
PFC9L	Port 9 function control register L	Port	186
PFCCD	Port CD function control register	Port	195
PFCE0	Port 0 function control expansion register	Port	143
PFCE3	Port 3 function control expansion register	Port	153
PFCE3H	Port 3 function control expansion register H	Port	153
PFCE3L	Port 3 function control expansion register L	Port	153
PFCE5	Port 5 function control expansion register	Port	164
PFCE6	Port 6 function control expansion register	Port	171
PFCE6H	Port 6 function control expansion register H	Port	171

Symbol	Name	Unit	Page
PFCE6L	Port 6 function control expansion register L	Port	171
PFCE8	Port 8 function control expansion register	Port	180
PFCE9	Port 9 function control expansion register	Port	186
PFCE9H	Port 9 function control expansion register H	Port	186
PFCE9L	Port 9 function control expansion register L	Port	186
PIC0	Interrupt control register	INTC	1296
PIC1	Interrupt control register	INTC	1296
PIC2	Interrupt control register	INTC	1296
PIC3	Interrupt control register	INTC	1296
PIC4	Interrupt control register	INTC	1296
PIC5	Interrupt control register	INTC	1296
PIC6	Interrupt control register	INTC	1296
PIC7	Interrupt control register	INTC	1296
PIC8	Interrupt control register	INTC	1296
PIC9	Interrupt control register	INTC	1296
PLLCTL	PLL control register	CG	348
PLLS	PLL lockup time specification register	CG	351
PM0	Port 0 mode register	Port	142
PM1	Port 1 mode register	Port	145
PM2	Port 2 mode register	Port	146
PM3	Port 3 mode register	Port	150
PM3H	Port 3 mode register H	Port	150
PM3L	Port 3 mode register L	Port	150
PM4	Port 4 mode register	Port	158
PM5	Port 5 mode register	Port	162
PM6	Port 6 mode register	Port	168
PM6H	Port 6 mode register H	Port	168
PM6L	Port 6 mode register L	Port	168
PM7H	Port 7 mode register H	Port	176
PM7L	Port 7 mode register L	Port	176
PM8	Port 8 mode register	Port	178
PM9	Port 9 mode register	Port	183
PM9H	Port 9 mode register H	Port	183
PM9L	Port 9 mode register L	Port	183
PM13	Port 13 mode register	Port	190
PM14	Port 14 mode register	Port	191
PM15	Port 15 mode register	Port	192
PMC0	Port 0 mode control register	Port	142
PMC2	Port 2 mode control register	Port	147
PMC3	Port 3 mode control register	Port	151
PMC3H	Port 3 mode control register H	Port	151
PMC3L	Port 3 mode control register L	Port	151
PMC4	Port 4 mode control register	Port	159
PMC5	Port 5 mode control register	Port	163



Symbol	Name	Unit	Page
PMC6	Port 6 mode control register	Port	169
PMC6H	Port 6 mode control register H	Port	169
PMC6L	Port 6 mode control register L	Port	169
PMC8	Port 8 mode control register	Port	179
PMC9	Port 9 mode control register	Port	184
PMC9H	Port 9 mode control register H	Port	184
PMC9L	Port 9 mode control register L	Port	184
PMC15	Port 15 mode control register	Port	193
PMCCD	Port CD mode control register	Port	195
PMCCM	Port CM mode control register	Port	197
PMCCS	Port CS mode control register	Port	199
PMCCT	Port CT mode control register	Port	201
PMCD	Port CD mode register	Port	194
PMCDH	Port DH mode control register	Port	203
PMCDL	Port DL mode control register	Port	206
PMCDLH	Port DL mode control register H	Port	206
PMCDLL	Port DL mode control register L	Port	206
PMCM	Port CM mode register	Port	196
PMCS	Port CS mode register	Port	198
PMCT	Port CT mode register	Port	200
PMDH	Port DH mode register	Port	202
PMDL	Port DL mode register	Port	205
PMDLH	Port DL mode register H	Port	205
PMDLL	Port DL mode register L	Port	205
PRCMD	Command register	CPU	126
PRDSELH	Product selection register H	CPU	99
PRDSELL	Product selection register L	CPU	99
PRSCM0	Prescaler compare register 0	WT	625
PRSCM1	BRG1 prescaler compare register	CSI	876
PRSCM2	BRG2 prescaler compare register	CSI	876
PRSCM3	BRG3 prescaler compare register	CSI	876
PRSM0	Prescaler mode register 0	WT	624
PRSM1	BRG1 prescaler mode register	CSI	875
PRSM2	BRG2 prescaler mode register	CSI	875
PRSM3	BRG3 prescaler mode register	CSI	875
PSC	Power save control register	CG	1330
PSMR	Power save mode register	CG	1331
PSR	IEBus power save register	IEBus	1036
PSW	Program status word	CPU	80
r0-r31	General-purpose register	CPU	76
RAMS	Internal RAM data status register	CG	1377
RC1ALH	Alarm hour setting register	RTC	647
RC1ALM	Alarm minute setting register	RTC	647
RC1ALW	Alarm week setting register	RTC	648

Symbol	Name	Unit	Page
RC1CC0	Real-time counter control register 0	RTC	636
RC1CC1	Real-time counter control register 1	RTC	636
RC1CC2	Real-time counter control register 2	RTC	638
RC1CC3	Real-time counter control register 3	RTC	639
RC1DAY	Day count register	RTC	643
RC1HOUR	Hour count register	RTC	641
RC1MIN	Minute count register	RTC	641
RC1MONTH	Month count register	RTC	645
RC1SEC	Second count register	RTC	640
RC1SUBC	Subcount register	RTC	640
RC1SUBU	Watch error correction register	RTC	646
RC1WEEK	Week count register	RTC	644
RC1YEAR	Year count register	RTC	645
RCM	Internal oscillation mode register	CG	347
RECIC0	Interrupt control register	INTC	1296
RECIC1	Interrupt control register	INTC	1296
RESF	Reset source flag register	LVI	1360
RSA	IEBus receive slave address register	IEBus	1050
RTBH0	Real-time output buffer register 0H	RTP	670
RTBH1	Real-time output buffer register 1H	RTP	670
RTBL0	Real-time output buffer register 0L	RTP	670
RTBL1	Real-time output buffer register 1L	RTP	670
RTC0IC	Interrupt control register	INTC	1296
RTC1IC	Interrupt control register	INTC	1296
RTC2IC	Interrupt control register	INTC	1296
RTPC0	Real-time output port control register 0	RTP	672
RTPC1	Real-time output port control register 1	RTP	672
RTPM0	Real-time output port mode register 0	RTP	671
RTPM1	Real-time output port mode register 1	RTP	671
SAR	IEBus slave address register	IEBus	1049
SCR	IEBus success count register	IEBus	1058
SELCNT0	Selector operation control register 0	Timer	500
SFC0	SSCG frequency control register 0	CG	353
SFC1	SSCG frequency control register 1	CG	354
SSCGCTL	SSCG control register	CG	352
SSR	IEBus slave status register	IEBus	1037
STAIC	Interrupt control register	INTC	1296
SVA0	Slave address register 0	I <sup>2</sup> C	953
SVA1	Slave address register 1	I <sup>2</sup> C	953
SVA2	Slave address register 2	I <sup>2</sup> C	953
SVA3	Slave address register 3	I <sup>2</sup> C	953
SVA4	Slave address register 4	I <sup>2</sup> C	953
SVA5	Slave address register 5	I <sup>2</sup> C	953
SYS	System status register	CPU	127

Symbol	Name	Unit	Page
TM0CMP0	TMM0 compare register 0	Timer	614
TM0CTL0	TMM0 control register 0	Timer	615
TM0EQIC0	Interrupt control register	INTC	1296
TM1CMP0	TMM1 compare register 0	Timer	614
TM1CTL0	TMM1 control register 0	Timer	615
TM1EQIC0	Interrupt control register	INTC	1296
TM2CMP0	TMM2 compare register 0	Timer	614
TM2CTL0	TMM2 control register 0	Timer	615
TM2EQIC0	Interrupt control register	INTC	1296
TP0CCIC0	Interrupt control register	INTC	1296
TP0CCIC1	Interrupt control register	INTC	1296
TP0CCR0	TMP0 capture/compare register 0	Timer	387
TP0CCR1	TMP0 capture/compare register 1	Timer	389
TP0CNT	TMP0 counter read buffer register	Timer	391
TP0CTL0	TMP0 control register 0	Timer	373
TP0CTL1	TMP0 control register 1	Timer	374
TP0IOC0	TMP0 I/O control register 0	Timer	378
TP0IOC1	TMP0 I/O control register 1	Timer	380
TP0IOC2	TMP0 I/O control register 2	Timer	381
TP0OPT0	TMP0 option register 0	Timer	384
TP0OVIC	Interrupt control register	INTC	1296
TP1CCIC0	Interrupt control register	INTC	1296
TP1CCIC1	Interrupt control register	INTC	1296
TP1CCR0	TMP1 capture/compare register 0	Timer	387
TP1CCR1	TMP1 capture/compare register 1	Timer	389
TP1CNT	TMP1 counter read buffer register	Timer	391
TP1CTL0	TMP1 control register 0	Timer	373
TP1CTL1	TMP1 control register 1	Timer	374
TP1IOC0	TMP1 I/O control register 0	Timer	378
TP1IOC1	TMP1 I/O control register 1	Timer	380
TP1IOC2	TMP1 I/O control register 2	Timer	381
TP1OPT0	TMP1 option register 0	Timer	384
TP1OVIC	Interrupt control register	INTC	1296
TP2CCIC0	Interrupt control register	INTC	1296
TP2CCIC1	Interrupt control register	INTC	1296
TP2CCR0	TMP2 capture/compare register 0	Timer	387
TP2CCR1	TMP2 capture/compare register 1	Timer	389
TP2CNT	TMP2 counter read buffer register	Timer	391
TP2CTL0	TMP2 control register 0	Timer	373
TP2CTL1	TMP2 control register 1	Timer	374
TP2IOC0	TMP2 I/O control register 0	Timer	378
TP2IOC1	TMP2 I/O control register 1	Timer	380
TP2IOC2	TMP2 I/O control register 2	Timer	381
TP2OPT0	TMP2 option register 0	Timer	384

Symbol	Name	Unit	Page
TP2OVIC	Interrupt control register	INTC	1296
TP3CCIC0	Interrupt control register	INTC	1296
TP3CCIC1	Interrupt control register	INTC	1296
TP3CCR0	TMP3 capture/compare register 0	Timer	387
TP3CCR1	TMP3 capture/compare register 1	Timer	389
TP3CNT	TMP3 counter read buffer register	Timer	391
TP3CTL0	TMP3 control register 0	Timer	373
TP3CTL1	TMP3 control register 1	Timer	374
TP3IOC0	TMP3 I/O control register 0	Timer	378
TP3IOC1	TMP3 I/O control register 1	Timer	380
TP3IOC2	TMP3 I/O control register 2	Timer	381
TP3OPT0	TMP3 option register 0	Timer	384
TP3OVIC	Interrupt control register	INTC	1296
TP4CCIC0	Interrupt control register	INTC	1296
TP4CCIC1	Interrupt control register	INTC	1296
TP4CCR0	TMP4 capture/compare register 0	Timer	387
TP4CCR1	TMP4 capture/compare register 1	Timer	389
TP4CNT	TMP4 counter read buffer register	Timer	391
TP4CTL0	TMP4 control register 0	Timer	373
TP4CTL1	TMP4 control register 1	Timer	374
TP4IOC0	TMP4 I/O control register 0	Timer	378
TP4IOC1	TMP4 I/O control register 1	Timer	380
TP4IOC2	TMP4 I/O control register 2	Timer	381
TP4OPT0	TMP4 option register 0	Timer	384
TP4OVIC	Interrupt control register	INTC	1296
TP5CCIC0	Interrupt control register	INTC	1296
TP5CCIC1	Interrupt control register	INTC	1296
TP5CCR0	TMP5 capture/compare register 0	Timer	387
TP5CCR1	TMP5 capture/compare register 1	Timer	389
TP5CNT	TMP5 counter read buffer register	Timer	391
TP5CTL0	TMP5 control register 0	Timer	373
TP5CTL1	TMP5 control register 1	Timer	374
TP5IOC0	TMP5 I/O control register 0	Timer	378
TP5IOC1	TMP5 I/O control register 1	Timer	380
TP5IOC2	TMP5 I/O control register 2	Timer	381
TP5OPT0	TMP5 option register 0	Timer	384
TP5OVIC	Interrupt control register	INTC	1296
TP6CCIC0	Interrupt control register	INTC	1296
TP6CCIC1	Interrupt control register	INTC	1296
TP6CCR0	TMP6 capture/compare register 0	Timer	387
TP6CCR1	TMP6 capture/compare register 1	Timer	389
TP6CNT	TMP6 counter read buffer register	Timer	391
TP6CTL0	TMP6 control register 0	Timer	373
TP6CTL1	TMP6 control register 1	Timer	374

Symbol	Name	Unit	Page
TP6IOC0	TMP6 I/O control register 0	Timer	378
TP6IOC1	TMP6 I/O control register 1	Timer	380
TP6IOC2	TMP6 I/O control register 2	Timer	381
TP6OPT0	TMP6 option register 0	Timer	384
TP6OVIC	Interrupt control register	INTC	1296
TP7CCIC0	Interrupt control register	INTC	1296
TP7CCIC1	Interrupt control register	INTC	1296
TP7CCR0	TMP7 capture/compare register 0	Timer	387
TP7CCR1	TMP7 capture/compare register 1	Timer	389
TP7CNT	TMP7 counter read buffer register	Timer	391
TP7CTL0	TMP7 control register 0	Timer	373
TP7CTL1	TMP7 control register 1	Timer	374
TP7CTL2	TMP7 control register 2	Timer	376
TP7IECIC	Interrupt control register	INTC	1296
TP7IOC0	TMP7 I/O control register 0	Timer	378
TP7IOC1	TMP7 I/O control register 1	Timer	380
TP7IOC2	TMP7 I/O control register 2	Timer	381
TP7IOC3	TMP7 I/O control register 3	Timer	382
TP7OPT0	TMP7 option register 0	Timer	384
TP7OPT1	TMP7 option register 1	Timer	385
TP7OVIC	Interrupt control register	INTC	1296
TP7TCW	TMP7 counter write register	Timer	391
TP8CCIC0	Interrupt control register	INTC	1296
TP8CCIC1	Interrupt control register	INTC	1296
TP8CCR0	TMP8 capture/compare register 0	Timer	387
TP8CCR1	TMP8 capture/compare register 1	Timer	389
TP8CNT	TMP8 counter read buffer register	Timer	391
TP8CTL0	TMP8 control register 0	Timer	373
TP8CTL1	TMP8 control register 1	Timer	374
TP8CTL2	TMP8 control register 2	Timer	376
TP8IECIC	Interrupt control register	INTC	1296
TP8IOC0	TMP8 I/O control register 0	Timer	378
TP8IOC1	TMP8 I/O control register 1	Timer	380
TP8IOC2	TMP8 I/O control register 2	Timer	381
TP8IOC3	TMP8 I/O control register 3	Timer	382
TP8OPT0	TMP8 option register 0	Timer	384
TP8OPT1	TMP8 option register 1	Timer	385
TP8OVIC	Interrupt control register	INTC	1296
TP8TCW	TMP8 counter write register	Timer	391
TQ0CCIC0	Interrupt control register	INTC	1296
TQ0CCIC1	Interrupt control register	INTC	1296
TQ0CCIC2	Interrupt control register	INTC	1296
TQ0CCIC3	Interrupt control register	INTC	1296
TQ0CCR0	TMQ0 capture/compare register 0	Timer	513

Symbol	Name	Unit	Page
TQ0CCR1	TMQ0 capture/compare register 1	Timer	515
TQ0CCR2	TMQ0 capture/compare register 2	Timer	517
TQ0CCR3	TMQ0 capture/compare register 3	Timer	519
TQ0CNT	TMQ0 counter read buffer register	Timer	521
TQ0CTL0	TMQ0 control register 0	Timer	507
TQ0CTL1	TMQ0 control register 1	Timer	508
TQ0IOC0	TMQ0 I/O control register 0	Timer	509
TQ0IOC1	TMQ0 I/O control register 1	Timer	510
TQ0IOC2	TMQ0 I/O control register 2	Timer	511
TQ0OPT0	TMQ0 option register 0	Timer	512
TQ0OVIC	Interrupt control register	INTC	1296
TRXIC0	Interrupt control register	INTC	1296
TRXIC1	Interrupt control register	INTC	1296
UA0CTL0	UARTA0 control register 0	UART	725
UA0CTL1	UARTA0 control register 1	UART	749
UA0CTL2	UARTA0 control register 2	UART	750
UA0OPT0	UARTA0 option control register 0	UART	727
UA0RIC	Interrupt control register	INTC	1296
UA0RX	UARTA0 receive data register	UART	731
UA0STR	UARTA0 status register	UART	729
UA0TIC	Interrupt control register	INTC	1296
UA0TX	UARTA0 transmit data register	UART	731
UA1CTL0	UARTA1 control register 0	UART	725
UA1CTL1	UARTA1 control register 1	UART	749
UA1CTL2	UARTA1 control register 2	UART	750
UA1OPT0	UARTA1 option control register 0	UART	727
UA1RIC	Interrupt control register	INTC	1296
UA1RX	UARTA1 receive data register	UART	731
UA1STR	UARTA1 status register	UART	729
UA1TIC	Interrupt control register	INTC	1296
UA1TX	UARTA1 transmit data register	UART	731
UA2CTL0	UARTA2 control register 0	UART	725
UA2CTL1	UARTA2 control register 1	UART	749
UA2CTL2	UARTA2 control register 2	UART	750
UA2OPT0	UARTA2 option control register 0	UART	727
UA2RIC	Interrupt control register	INTC	1296
UA2RX	UARTA2 receive data register	UART	731
UA2STR	UARTA2 status register	UART	729
UA2TIC	Interrupt control register	INTC	1296
UA2TX	UARTA2 transmit data register	UART	731
UA3CTL0	UARTA3 control register 0	UART	725
UA3CTL1	UARTA3 control register 1	UART	749
UA3CTL2	UARTA3 control register 2	UART	750
UA3OPT0	UARTA3 option control register 0	UART	727

Symbol	Name	Unit	Page
UA3RIC	Interrupt control register	INTC	1296
UA3RX	UARTA3 receive data register	UART	731
UA3STR	UARTA3 status register	UART	729
UA3TIC	Interrupt control register	INTC	1296
UA3TX	UARTA3 transmit data register	UART	731
UA4CTL0	UARTA4 control register 0	UARTA	725
UA4CTL1	UARTA4 control register 1	UARTA	749
UA4CTL2	UARTA4 control register 2	UARTA	750
UA4OPT0	UARTA4 option control register 0	UARTA	727
UA4RIC	Interrupt control register	INTC	1296
UA4RX	UARTA4 receive data register	UARTA	731
UA4STR	UARTA4 status register	UARTA	729
UA4TIC	Interrupt control register	INTC	1296
UA4TX	UARTA4 transmit data register	UARTA	731
UA5CTL0	UARTA5 control register 0	UARTA	725
UA5CTL1	UARTA5 control register 1	UARTA	749
UA5CTL2	UARTA5 control register 2	UARTA	750
UA5OPT0	UARTA5 option control register 0	UARTA	727
UA5RIC	Interrupt control register	INTC	1296
UA5RX	UARTA5 receive data register	UARTA	731
UA5STR	UARTA5 status register	UARTA	729
UA5TIC	Interrupt control register	INTC	1296
UA5TX	UARTA5 transmit data register	UARTA	731
UAR	IEBus unit address register	IEBus	1049
UB0CTL0	UARTB0 control register 0	UARTB	764
UB0CTL2	UARTB0 control register 2	UARTB	770
UB0FIC0	UARTB0 FIFO control register 0	UARTB	774
UB0FIC1	UARTB0 FIFO control register 1	UARTB	778
UB0FIC2	UARTB0 FIFO control register 2	UARTB	779
UB0FIC2H	UARTB0 FIFO control register 2H	UARTB	779
UB0FIC2L	UARTB0 FIFO control register 2L	UARTB	779
UB0FIS0	UARTB0 FIFO status register 0	UARTB	781
UB0FIS1	UARTB0 FIFO status register 1	UARTB	782
UB0RX	UARTB0 receive data register	UARTB	772
UB0RXAP	UARTB0 receive data register AP	UARTB	772
UB0STR	UARTB0 status register	UARTB	767
UB0TIFIC	Interrupt control register	INTC	1296
UB0TIREIC	Interrupt control register	INTC	1296
UB0TIRIC	Interrupt control register	INTC	1296
UB0TITIC	Interrupt control register	INTC	1296
UB0TITOIC	Interrupt control register	INTC	1296
UB0TX	UARTB0 transmit data register	UARTB	771
UB1CTL0	UARTB1 control register 0	UARTB	764
UB1CTL2	UARTB1 control register 2	UARTB	770

Symbol	Name	Unit	Page
UB1FIC0	UARTB1 FIFO control register 0	UARTB	774
UB1FIC1	UARTB1 FIFO control register 1	UARTB	778
UB1FIC2	UARTB1 FIFO control register 2	UARTB	779
UB1FIC2H	UARTB1 FIFO control register 2H	UARTB	779
UB1FIC2L	UARTB1 FIFO control register 2L	UARTB	779
UB1FIS0	UARTB1 FIFO status register 0	UARTB	781
UB1FIS1	UARTB1 FIFO status register 1	UARTB	782
UB1RX	UARTB1 receive data register	UARTB	772
UB1RXAP	UARTB1 receive data register AP	UARTB	772
UB1STR	UARTB1 status register	UARTB	767
UB1TIFIC	Interrupt control register	INTC	1296
UB1TIREIC	Interrupt control register	INTC	1296
UB1TIRIC	Interrupt control register	INTC	1296
UB1TITIC	Interrupt control register	INTC	1296
UB1TITOIC	Interrupt control register	INTC	1296
UB1TX	UARTB1 transmit data register	UARTB	771
USR	IEBus unit status register	IEBus	1038
VSWC	System wait control register	CPU	128
WDTE	Watchdog timer enable register	WDT	666
WDTM2	Watchdog timer mode register 2	WDT	663
WTIC	Interrupt control register	INTC	1296
WTIIC	Interrupt control register	INTC	1296
WTM	Watch timer operation mode register	WT	628
WUPIC0	Interrupt control register	INTC	1296
WUPIC1	Interrupt control register	INTC	1296



## APPENDIX C INSTRUCTION SET LIST

### C.1 Conventions

#### (1) Register symbols used to describe operands

Register Symbol	Explanation
reg1	General-purpose registers: Used as source registers.
reg2	General-purpose registers: Used mainly as destination registers. Also used as source register in some instructions.
reg3	General-purpose registers: Used mainly to store the remainders of division results and the higher order 32 bits of multiplication results.
bit#3	3-bit data for specifying the bit number
immX	X bit immediate data
dispX	X bit displacement data
regID	System register number
vector	5-bit data that specifies the trap vector (00H to 1FH)
cccc	4-bit data that shows the conditions code
sp	Stack pointer (SP)
ep	Element pointer (r30)
listX	X item register list

#### (2) Register symbols used to describe opcodes

Register Symbol	Explanation
R	1-bit data of a code that specifies reg1 or regID
r	1-bit data of the code that specifies reg2
w	1-bit data of the code that specifies reg3
d	1-bit displacement data
l	1-bit immediate data (indicates the higher bits of immediate data)
i	1-bit immediate data
cccc	4-bit data that shows the condition codes
CCCC	4-bit data that shows the condition codes of Bcond instruction
bbb	3-bit data for specifying the bit number
L	1-bit data that specifies a program register in the register list
S	1-bit data that specifies a system register in the register list

**(3) Register symbols used in operations**

Register Symbol	Explanation
←	Input for
GR [ ]	General-purpose register
SR [ ]	System register
zero-extend (n)	Expand n with zeros until word length.
sign-extend (n)	Expand n with signs until word length.
load-memory (a, b)	Read size b data from address a.
store-memory (a, b, c)	Write data b into address a in size c.
load-memory-bit (a, b)	Read bit b of address a.
store-memory-bit (a, b, c)	Write c to bit b of address a.
saturated (n)	Execute saturated processing of n (n is a 2's complement). If, as a result of calculations, n ≥ 7FFFFFFFH, let it be 7FFFFFFFH. n ≤ 80000000H, let it be 80000000H.
result	Reflects the results in a flag.
Byte	Byte (8 bits)
Halfword	Half word (16 bits)
Word	Word (32 bits)
+	Addition
–	Subtraction
	Bit concatenation
×	Multiplication
÷	Division
%	Remainder from division results
AND	Logical product
OR	Logical sum
XOR	Exclusive OR
NOT	Logical negation
logically shift left by	Logical shift left
logically shift right by	Logical shift right
arithmetically shift right by	Arithmetic shift right

**(4) Register symbols used in execution clock**

Register Symbol	Explanation
i	If executing another instruction immediately after executing the first instruction (issue).
r	If repeating execution of the same instruction immediately after executing the first instruction (repeat).
l	If using the results of instruction execution in the instruction immediately after the execution (latency).

**(5) Register symbols used in flag operations**

Identifier	Explanation
(Blank)	No change
0	Clear to 0
X	Set or cleared in accordance with the results.
R	Previously saved values are restored.

**(6) Condition codes**

Condition Name (cond)	Condition Code (cccc)	Condition Formula	Explanation
V	0 0 0 0	$OV = 1$	Overflow
NV	1 0 0 0	$OV = 0$	No overflow
C/L	0 0 0 1	$CY = 1$	Carry Lower (Less than)
NC/NL	1 0 0 1	$CY = 0$	No carry Not lower (Greater than or equal)
Z/E	0 0 1 0	$Z = 1$	Zero Equal
NZ/NE	1 0 1 0	$Z = 0$	Not zero Not equal
NH	0 0 1 1	$(CY \text{ or } Z) = 1$	Not higher (Less than or equal)
H	1 0 1 1	$(CY \text{ or } Z) = 0$	Higher (Greater than)
N	0 1 0 0	$S = 1$	Negative
P	1 1 0 0	$S = 0$	Positive
T	0 1 0 1	–	Always (Unconditional)
SA	1 1 0 1	$SAT = 1$	Saturated
LT	0 1 1 0	$(S \text{ xor } OV) = 1$	Less than signed
GE	1 1 1 0	$(S \text{ xor } OV) = 0$	Greater than or equal signed
LE	0 1 1 1	$((S \text{ xor } OV) \text{ or } Z) = 1$	Less than or equal signed
GT	1 1 1 1	$((S \text{ xor } OV) \text{ or } Z) = 0$	Greater than signed

C.2 Instruction Set (in Alphabetical Order)

(1/6)

Mnemonic	Operand	Opcode	Operation	Execution Clock			Flags					
				i	r	l	CY	OV	S	Z	SAT	
ADD	reg1,reg2	rrrrr001110RRRRR	GR[reg2]←GR[reg2]+GR[reg1]	1	1	1	x	x	x	x		
	imm5,reg2	rrrrr010010iiii	GR[reg2]←GR[reg2]+sign-extend(imm5)	1	1	1	x	x	x	x		
ADDI	imm16,reg1,reg2	rrrrr110000RRRRR iiiiiiiiiiiiiiii	GR[reg2]←GR[reg1]+sign-extend(imm16)	1	1	1	x	x	x	x		
AND	reg1,reg2	rrrrr001010RRRRR	GR[reg2]←GR[reg2]AND GR[reg1]	1	1	1		0	x	x		
ANDI	imm16,reg1,reg2	rrrrr110110RRRRR iiiiiiiiiiiiiiii	GR[reg2]←GR[reg1]AND zero-extend(imm16)	1	1	1		0	0	x		
Bcond	disp9	dddd1011ddcccc <b>Note 1</b>	if conditions are satisfied then PC←PC+sign-extend(disp9)	When conditions are satisfied	3	3	3					
				When conditions are not satisfied	1	1	1					
BSH	reg2,reg3	rrrrr11111100000 wwwww01101000010	GR[reg3]←GR[reg2] (23:16)    GR[reg2] (31:24)    GR[reg2] (7:0)    GR[reg2] (15:8)	1	1	1	x	0	x	x		
BSW	reg2,reg3	rrrrr11111100000 wwwww01101000000	GR[reg3]←GR[reg2] (7:0)    GR[reg2] (15:8)    GR [reg2] (23:16)    GR[reg2] (31:24)	1	1	1	x	0	x	x		
CALLT	imm6	0000001000iiii	CTPC←PC+2(return PC) CTPSW←PSW adr←CTBP+zero-extend(imm6 logically shift left by 1) PC←CTBP+zero-extend(Load-memory(adr,Halfword))	5	5	5						
CLR1	bit#3, disp16[reg1]	10bbb111110RRRRR dddddddddddd	adr←GR[reg1]+sign-extend(disp16) Z flag←Not(Load-memory-bit(adr,bit#3)) Store-memory-bit(adr,bit#3,0)	3	3	3					x	
	reg2,[reg1]	rrrrr111111RRRRR 0000000011100100	adr←GR[reg1] Z flag←Not(Load-memory-bit(adr,reg2)) Store-memory-bit(adr,reg2,0)	3	3	3					x	
CMOV	cccc,imm5,reg2,reg3	rrrrr111111iiii wwwww011000cccc0	if conditions are satisfied then GR[reg3]←sign-extended(imm5) else GR[reg3]←GR[reg2]	1	1	1						
	cccc,reg1,reg2,reg3	rrrrr111111RRRR wwwww011001cccc0	if conditions are satisfied then GR[reg3]←GR[reg1] else GR[reg3]←GR[reg2]	1	1	1						
CMP	reg1,reg2	rrrrr001111RRRRR	result←GR[reg2]-GR[reg1]	1	1	1	x	x	x	x		
	imm5,reg2	rrrrr010011iiii	result←GR[reg2]-sign-extend(imm5)	1	1	1	x	x	x	x		
CTRET		000001111100000 0000000101000100	PC←CTPC PSW←CTPSW	4	4	4	R	R	R	R	R	
DBRET		000001111100000 0000000101000110	PC←DBPC PSW←DBPSW	4	4	4	R	R	R	R	R	

APPENDIX C INSTRUCTION SET LIST

(2/6)

Mnemonic	Operand	Opcode	Operation	Execution Clock			Flags					
				i	r	l	CY	OV	S	Z	SAT	
DBTRAP		1111100001000000	DBPC←PC+2(return PC) DBPSW←PSW PSW.NP←1 PSW.EP←1 PSW.ID←1 PC←0000060H	4	4	4						
DI		0000011111100000 0000000101100000	PSW.ID←1	1	1	1						
DISPOSE	imm5,list12	0000011001iiiiL LLLLLLLLLLLL00000	sp←sp+zero-extend(imm5 logically shift left by 2) GR[reg in list12]←Load-memory(sp,Word) sp←sp+4 repeat 2 steps above until all regs in list12 is loaded	n+1 Note 4	n+1 Note 4	n+1 Note 4						
	imm5,list12,[reg1]	0000011001iiiiL LLLLLLLLLLLLRRRRR Note 5	sp←sp+zero-extend(imm5 logically shift left by 2) GR[reg in list12]←Load-memory(sp,Word) sp←sp+4 repeat 2 steps above until all regs in list12 is loaded PC←GR[reg1]	n+3 Note 4	n+3 Note 4	n+3 Note 4						
DIV	reg1,reg2,reg3	rrrrr11111RRRRR wwwww01011000000	GR[reg2]←GR[reg2]÷GR[reg1] GR[reg3]←GR[reg2]%GR[reg1]	35	35	35		×	×	×		
DIVH	reg1,reg2	rrrrr000010RRRRR	GR[reg2]←GR[reg2]÷GR[reg1] <sup>Note 6</sup>	35	35	35		×	×	×		
	reg1,reg2,reg3	rrrrr11111RRRRR wwwww01010000000	GR[reg2]←GR[reg2]÷GR[reg1] <sup>Note 6</sup> GR[reg3]←GR[reg2]%GR[reg1]	35	35	35		×	×	×		
DIVHU	reg1,reg2,reg3	rrrrr11111RRRRR wwwww01010000010	GR[reg2]←GR[reg2]÷GR[reg1] <sup>Note 6</sup> GR[reg3]←GR[reg2]%GR[reg1]	34	34	34		×	×	×		
DIVU	reg1,reg2,reg3	rrrrr11111RRRRR wwwww01011000010	GR[reg2]←GR[reg2]÷GR[reg1] GR[reg3]←GR[reg2]%GR[reg1]	34	34	34		×	×	×		
EI		1000011111100000 0000000101100000	PSW.ID←0	1	1	1						
HALT		0000011111100000 0000000100100000	Stop	1	1	1						
HSW	reg2,reg3	rrrrr11111100000 wwwww01101000100	GR[reg3]←GR[reg2](15:0)    GR[reg2] (31:16)	1	1	1	×	0	×	×		
JARL	disp22,reg2	rrrrr11110dddddd ddddddddddddddd0 Note 7	GR[reg2]←PC+4 PC←PC+sign-extend(disp22)	3	3	3						
JMP	[reg1]	0000000011RRRRR	PC←GR[reg1]	4	4	4						
JR	disp22	0000011110dddddd ddddddddddddddd0 Note 7	PC←PC+sign-extend(disp22)	3	3	3						
LD.B	disp16[reg1],reg2	rrrrr111000RRRRR ddddddddddddddd	adr←GR[reg1]+sign-extend(disp16) GR[reg2]←sign-extend(Load-memory(adr,Byte))	1	1	Note 11						
LD.BU	disp16[reg1],reg2	rrrrr11110bRRRRR ddddddddddddddd1 Notes 8, 10	adr←GR[reg1]+sign-extend(disp16) GR[reg2]←zero-extend(Load-memory(adr,Byte))	1	1	Note 11						

APPENDIX C INSTRUCTION SET LIST

(3/6)

Mnemonic	Operand	Opcode	Operation	Execution Clock			Flags					
				i	r	l	CY	OV	S	Z	SAT	
LD.H	disp16[reg1],reg2	rrrrr111001RRRRR dddddddddddddd0 <b>Note 8</b>	adr←GR[reg1]+sign-extend(disp16) GR[reg2]←sign-extend(Load-memory(adr,Halfword))	1	1	Note 11						
LDSR	reg2,regID	rrrrr111111RRRRR 000000000100000 <b>Note 12</b>	SR[regID]←GR[reg2]      Other than regID = PSW	1	1	1						
			regID = PSW	1	1	1	×	×	×	×	×	
LD.HU	disp16[reg1],reg2	rrrrr111111RRRRR dddddddddddddd1 <b>Note 8</b>	adr←GR[reg1]+sign-extend(disp16) GR[reg2]←zero-extend(Load-memory(adr,Halfword))	1	1	Note 11						
LD.W	disp16[reg1],reg2	rrrrr111001RRRRR dddddddddddddd1 <b>Note 8</b>	adr←GR[reg1]+sign-extend(disp16) GR[reg2]←Load-memory(adr,Word)	1	1	Note 11						
MOV	reg1,reg2	rrrrr000000RRRRR	GR[reg2]←GR[reg1]	1	1	1						
	imm5,reg2	rrrrr010000iiii	GR[reg2]←sign-extend(imm5)	1	1	1						
	imm32,reg1	00000110001RRRRR iiiiiiiiiiiiiiii iiiiiiiiiiiiiiii	GR[reg1]←imm32	2	2	2						
MOVEA	imm16,reg1,reg2	rrrrr110001RRRRR iiiiiiiiiiiiiiii	GR[reg2]←GR[reg1]+sign-extend(imm16)	1	1	1						
MOVHI	imm16,reg1,reg2	rrrrr110010RRRRR iiiiiiiiiiiiiiii	GR[reg2]←GR[reg1]+(imm16 II 0 <sup>16</sup> )	1	1	1						
MUL <sup>Note 22</sup>	reg1,reg2,reg3	rrrrr111111RRRRR wwwww01000100000	GR[reg3] II GR[reg2]←GR[reg2]xGR[reg1]	1	2	2						
	imm9,reg2,reg3	rrrrr111111iiii wwwww01001111100 <b>Note 13</b>	GR[reg3] II GR[reg2]←GR[reg2]xsign-extend(imm9)	1	2	2						
MULH	reg1,reg2	rrrrr000111RRRRR	GR[reg2]←GR[reg2] <sup>Note 6</sup> xGR[reg1] <sup>Note 6</sup>	1	1	2						
	imm5,reg2	rrrrr010111iiii	GR[reg2]←GR[reg2] <sup>Note 6</sup> xsign-extend(imm5)	1	1	2						
MULHI	imm16,reg1,reg2	rrrrr110111RRRRR iiiiiiiiiiiiiiii	GR[reg2]←GR[reg1] <sup>Note 6</sup> ximm16	1	1	2						
MULU <sup>Note 22</sup>	reg1,reg2,reg3	rrrrr111111RRRRR wwwww01000100010	GR[reg3] II GR[reg2]←GR[reg2]xGR[reg1]	1	2	2						
	imm9,reg2,reg3	rrrrr111111iiii wwwww0100111110 <b>Note 13</b>	GR[reg3] II GR[reg2]←GR[reg2]xzero-extend(imm9)	1	2	2						
NOP		000000000000000	Pass at least one clock cycle doing nothing.	1	1	1						
NOT	reg1,reg2	rrrrr000001RRRRR	GR[reg2]←NOT(GR[reg1])	1	1	1		0	×	×		
NOT1	bit#3,disp16[reg1]	01bbb111110RRRRR dddddddddddddd	adr←GR[reg1]+sign-extend(disp16) Z flag←Not(Load-memory-bit(adr,bit#3)) Store-memory-bit(adr,bit#3,Z flag)	3	3	3					×	
	reg2,[reg1]	rrrrr111111RRRRR 0000000011100010	adr←GR[reg1] Z flag←Not(Load-memory-bit(adr,reg2)) Store-memory-bit(adr,reg2,Z flag)	3	3	3					×	

Mnemonic	Operand	Opcode	Operation	Execution Clock			Flags				
				i	r	l	CY	OV	S	Z	SAT
OR	reg1,reg2	rrrrr001000RRRRR	GR[reg2]←GR[reg2]OR GR[reg1]	1	1	1		0	×	×	
ORI	imm16,reg1,reg2	rrrrr110100RRRRR iiiiiiiiiiiiiiii	GR[reg2]←GR[reg1]OR zero-extend(imm16)	1	1	1		0	×	×	
PREPARE	list12,imm5	0000011110iiiiL LLLLLLLLLLLL00001	Store-memory(sp−4,GR[reg in list12],Word) sp←sp−4 repeat 1 step above until all regs in list12 is stored sp←sp-zero-extend(imm5)	n+1 Note 4	n+1 Note 4	n+1 Note 4					
	list12,imm5, sp/imm <sup>Note 15</sup>	0000011110iiiiL LLLLLLLLLLLLff011 imm16/imm32 <b>Note 16</b>	Store-memory(sp−4,GR[reg in list12],Word) GR[reg in list 12]←Load-memory(sp,Word) sp←sp+4 repeat 2 step above until all regs in list12 is loaded PC←GR[reg1]	n+2 Note 4 Note 17	n+2 Note 4 Note 17	n+2 Note 4 Note 17					
RETI		000001111100000 0000000101000000	if PSW.EP=1 then PC ←EIPC PSW ←EIPSW else if PSW.NP=1 then PC ←FEPC PSW ←FEPSW else PC ←EIPC PSW ←EIPSW	4	4	4	R	R	R	R	R
SAR	reg1,reg2	rrrrr11111RRRRR 000000010100000	GR[reg2]←GR[reg2]arithmetically shift right by GR[reg1]	1	1	1	×	0	×	×	
	imm5,reg2	rrrrr010101iiii	GR[reg2]←GR[reg2]arithmetically shift right by zero-extend(imm5)	1	1	1	×	0	×	×	
SASF	cccc,reg2	rrrrr111110cccc 0000001000000000	if conditions are satisfied then GR[reg2]←(GR[reg2]Logically shift left by 1) OR 00000001H else GR[reg2]←(GR[reg2]Logically shift left by 1) OR 00000000H	1	1	1					
SATADD	reg1,reg2	rrrrr000110RRRRR	GR[reg2]←saturated(GR[reg2]+GR[reg1])	1	1	1	×	×	×	×	×
	imm5,reg2	rrrrr010001iiii	GR[reg2]←saturated(GR[reg2]+sign-extend(imm5))	1	1	1	×	×	×	×	×
SATSUB	reg1,reg2	rrrrr000101RRRRR	GR[reg2]←saturated(GR[reg2]−GR[reg1])	1	1	1	×	×	×	×	×
SATSUBI	imm16,reg1,reg2	rrrrr110011RRRRR iiiiiiiiiiiiiiii	GR[reg2]←saturated(GR[reg1]−sign-extend(imm16))	1	1	1	×	×	×	×	×
SATSUBR	reg1,reg2	rrrrr000100RRRRR	GR[reg2]←saturated(GR[reg1]−GR[reg2])	1	1	1	×	×	×	×	×
SETF	cccc,reg2	rrrrr111110cccc 0000000000000000	If conditions are satisfied then GR[reg2]←00000001H else GR[reg2]←00000000H	1	1	1					

APPENDIX C INSTRUCTION SET LIST

(5/6)

Mnemonic	Operand	Opcode	Operation	Execution Clock			Flags					
				i	r	l	CY	OV	S	Z	SAT	
SET1	bit#3,disp16[reg1]	00bbb111110RRRRR ddddddddddddddd	adr←GR[reg1]+sign-extend(disp16) Z flag←Not(Load-memory-bit(adr,bit#3)) Store-memory-bit(adr,bit#3,1)	3 Note 3	3 Note 3	3 Note 3					x	
	reg2,[reg1]	rrrrr111111RRRRR 0000000011100000	adr←GR[reg1] Z flag←Not(Load-memory-bit(adr,reg2)) Store-memory-bit(adr,reg2,1)	3 Note 3	3 Note 3	3 Note 3					x	
SHL	reg1,reg2	rrrrr111111RRRRR 0000000011000000	GR[reg2]←GR[reg2] logically shift left by GR[reg1]	1	1	1	x	0	x	x		
	imm5,reg2	rrrrr010110iiii	GR[reg2]←GR[reg2] logically shift left by zero-extend(imm5)	1	1	1	x	0	x	x		
SHR	reg1,reg2	rrrrr111111RRRRR 0000000010000000	GR[reg2]←GR[reg2] logically shift right by GR[reg1]	1	1	1	x	0	x	x		
	imm5,reg2	rrrrr010100iiii	GR[reg2]←GR[reg2] logically shift right by zero-extend(imm5)	1	1	1	x	0	x	x		
SLD.B	disp7[ep],reg2	rrrrr0110dddddd	adr←ep+zero-extend(disp7) GR[reg2]←sign-extend(Load-memory(adr,Byte))	1	1	Note 9						
SLD.BU	disp4[ep],reg2	rrrrr0000110ddd Note 18	adr←ep+zero-extend(disp4) GR[reg2]←zero-extend(Load-memory(adr,Byte))	1	1	Note 9						
SLD.H	disp8[ep],reg2	rrrrr1000dddddd Note 19	adr←ep+zero-extend(disp8) GR[reg2]←sign-extend(Load-memory(adr,Halfword))	1	1	Note 9						
SLD.HU	disp5[ep],reg2	rrrrr0000111ddd Notes 18, 20	adr←ep+zero-extend(disp5) GR[reg2]←zero-extend(Load-memory(adr,Halfword))	1	1	Note 9						
SLD.W	disp8[ep],reg2	rrrrr1010dddddd0 Note 21	adr←ep+zero-extend(disp8) GR[reg2]←Load-memory(adr,Word)	1	1	Note 9						
SST.B	reg2,disp7[ep]	rrrrr0111dddddd	adr←ep+zero-extend(disp7) Store-memory(adr,GR[reg2],Byte)	1	1	1						
SST.H	reg2,disp8[ep]	rrrrr1001dddddd Note 19	adr←ep+zero-extend(disp8) Store-memory(adr,GR[reg2],Halfword)	1	1	1						
SST.W	reg2,disp8[ep]	rrrrr1010dddddd1 Note 21	adr←ep+zero-extend(disp8) Store-memory(adr,GR[reg2],Word)	1	1	1						
ST.B	reg2,disp16[reg1]	rrrrr111010RRRRR ddddddddddddddd	adr←GR[reg1]+sign-extend(disp16) Store-memory(adr,GR[reg2],Byte)	1	1	1						
ST.H	reg2,disp16[reg1]	rrrrr111011RRRRR ddddddddddddddd0 Note 8	adr←GR[reg1]+sign-extend(disp16) Store-memory(adr,GR[reg2],Halfword)	1	1	1						
ST.W	reg2,disp16[reg1]	rrrrr111011RRRRR ddddddddddddddd1 Note 8	adr←GR[reg1]+sign-extend(disp16) Store-memory(adr,GR[reg2],Word)	1	1	1						
STSR	regID,reg2	rrrrr111111RRRRR 0000000010000000	GR[reg2]←SR[regID]	1	1	1						



Mnemonic	Operand	Opcode	Operation	Execution Clock			Flags				
				i	r	l	CY	OV	S	Z	SAT
SUB	reg1,reg2	rrrrr001101RRRRR	GR[reg2]←GR[reg2]−GR[reg1]	1	1	1	×	×	×	×	
SUBR	reg1,reg2	rrrrr001100RRRRR	GR[reg2]←GR[reg1]−GR[reg2]	1	1	1	×	×	×	×	
SWITCH	reg1	0000000010RRRRR	adr←(PC+2) + (GR[reg1] logically shift left by 1) PC←(PC+2) + (sign-extend (Load-memory(adr,Halfword)) logically shift left by 1	5	5	5					
SXB	reg1	00000000101RRRRR	GR[reg1]←sign-extend (GR[reg1] (7:0))	1	1	1					
SXH	reg1	00000000111RRRRR	GR[reg1]←sign-extend (GR[reg1] (15:0))	1	1	1					
TRAP	vector	000001111111iiii 0000000100000000	EIPC ←PC+4(return PC) EIPSW ←PSW ECR.EICC ←Exception code (40H to 4FH, 50H to 5FH) PSW.EP ←1 PSW.ID ←1 PC ←00000040H (when vector is 00H to 0FH (exception code: 40H to 4FH)) 00000050H (when vector is 10H to 1FH (exception code: 50H to 5FH))	4	4	4					
TST	reg1,reg2	rrrrr001011RRRRR	result←GR[reg2] AND GR[reg1]	1	1	1		0	×	×	
TST1	bit#3,disp16[reg1]	11bbb111110RRRRR ddddddddddddddd	adr←GR[reg1]+sign-extend(disp16) Z flag←Not(Load-memory-bit(adr,bit#3))	3	3	3	Note 3	Note 3	Note 3		×
	reg2, [reg1]	rrrrr111111RRRRR 0000000011100110	adr←GR[reg1] Z flag←Not(Load-memory-bit(adr,reg2))	3	3	3	Note 3	Note 3	Note 3		×
XOR	reg1,reg2	rrrrr001001RRRRR	GR[reg2]←GR[reg2] XOR GR[reg1]	1	1	1		0	×	×	
XORI	imm16,reg1,reg2	rrrrr110101RRRRR iiiiiiiiiiiiiiii	GR[reg2]←GR[reg1] XOR zero-extend(imm16)	1	1	1		0	×	×	
ZXB	reg1	00000000100RRRRR	GR[reg1]←zero-extend(GR[reg1] (7:0))	1	1	1					
ZXH	reg1	00000000110RRRRR	GR[reg1]←zero-extend(GR[reg1] (15:0))	1	1	1					

- Notes**
1. ddddddd: Higher 8 bits of disp9.
  2. 4 if there is an instruction that rewrites the contents of the PSW immediately before.
  3. If there is no wait state (3 + the number of read access wait states).
  4. n is the total number of list12 load registers. (According to the number of wait states. Also, if there are no wait states, n is the total number of list12 registers. If n = 0, same operation as when n = 1)
  5. RRRRR: other than 00000.
  6. The lower halfword data only are valid.
  7. ddddddddddddddddd: The higher 21 bits of disp22.
  8. ddddddddddddd: The higher 15 bits of disp16.
  9. According to the number of wait states (1 if there are no wait states).
  10. b: bit 0 of disp16.
  11. According to the number of wait states (2 if there are no wait states).

**Notes 12.** In this instruction, for convenience of mnemonic description, the source register is made reg2, but the reg1 field is used in the opcode. Therefore, the meaning of register specification in the mnemonic description and in the opcode differs from other instructions.

rrrrr = regID specification

RRRRR = reg2 specification

**13.** iiii: Lower 5 bits of imm9.

IIII: Higher 4 bits of imm9.

**14.** In the case of reg2 = reg3 (the lower 32 bits of the results are not written in the register) or reg3 = r0 (the higher 32 bits of the results are not written in the register), shortened by 1 clock.

**15.** sp/imm: specified by bits 19 and 20 of the sub-opcode.

**16.** ff = 00: Load sp in ep.

01: Load sign expanded 16-bit immediate data (bits 47 to 32) in ep.

10: Load 16-bit logically left shifted 16-bit immediate data (bits 47 to 32) in ep.

11: Load 32-bit immediate data (bits 63 to 32) in ep.

**17.** If imm = imm32, n + 3 clocks.

**18.** rrrrr: Other than 00000.

**19.** ddddddd: Higher 7 bits of disp8.

**20.** dddd: Higher 4 bits of disp5.

**21.** ddddd: Higher 6 bits of disp8.

**22.** Do not make a combination that satisfies all the following conditions when using the “MUL reg1, reg2, reg3” instruction and “MULU reg1, reg2, reg3” instruction. Operation is not guaranteed when an instruction that satisfies the following conditions is executed.

- Reg1 = reg3
- Reg1 ≠ reg2
- Reg1 ≠ r0
- Reg3 ≠ r0

## APPENDIX D LIST OF CAUTIONS

This appendix lists cautions described in this document.

“Classification (hard/soft)” in table is as follows.

Hard: Cautions for microcontroller internal/external hardware

Soft: Cautions for software such as register settings or programs

Chapter	Classification	Function	Details of Function	Cautions	Page
Chapter 1	Hard	Introduction	FLMD0	Set this pin to low level in the normal operation mode.	pp. 30, <input type="checkbox"/> 33
			REGC	Connect the REGC pin to Vss via a 4.7 $\mu$ F capacitor.	pp. 30, <input type="checkbox"/> 33
			DRST	Fix this pin to the low level from when the reset status has been released until the OCDM.OCDM0 bit is cleared (0) when the on-chip debug function is not used. For details, see 4.6.3 Cautions on on-chip debug pins.  In addition, this pin incorporates a pull-down resistor and it can be disconnected by clearing the CDM.OCDM0 bit.	pp. 30, <input type="checkbox"/> 33
			A0-A15	Port 9 cannot be used as port pins or other alternate-function pins when the A0 to A15 pins are used in the separate bus mode.	pp. 30, <input type="checkbox"/> 33
			ANI0-ANI15	To use port 7 (P70/ANI0 to P715/ANI15) as A/D converter function pins and port I/O pins in mix, be sure to observe usage cautions (refer to 13.6 (4) Alternate I/O).	pp. 30, <input type="checkbox"/> 33
Chapter 2	Hard	Pin functions	When using an alternate function that is assigned to two ports	When using an alternate function that is assigned to two ports, always use the alternate function at only one of the ports.	p. 60 <input type="checkbox"/>
			Cautions on power application	When the power is turned on, the following pins may momentarily output an undefined level. • P53/SIB2/KR3/TIQ00/TOQ00/RTP03/DDO pin	p. 73 <input type="checkbox"/>
Chapter 3	Soft	CPU function	EIPC register EIPSW register FEPC register FEPSW register	Because only one set of these registers is available, the contents of these registers must be saved by program if multiple interrupts are enabled.	p. 77 <input type="checkbox"/>
			EIPC, FEPC, CTPC register	Even if EIPC or FEPC, or bit 0 of CTPC is set to 1 by the LDSR instruction, bit 0 is ignored when execution is returned to the main routine by the RETI instruction after interrupt servicing (this is because bit 0 of the PC is fixed to 0). Set an even value to EIPC, FEPC, and CTPC (bit 0 = 0).	p. 77 <input type="checkbox"/>
			ASID register	Initialize the ASID register to 00H in its initialization routine.	p. 83 <input type="checkbox"/>
			Program space	Because the 4 KB area of addresses 03FFF000H to 03FFFFFFH is an on-chip peripheral I/O area, instructions cannot be fetched from this area. Therefore, do not execute an operation in which the result of a branch address calculation affects this area.	p. 86 <input type="checkbox"/>
			On-chip peripheral I/O area	If a register that can be accessed in byte units is accessed in halfword units, the higher 8 bits are undefined when the register is read, and data is written to the lower 8 bits.	p. 95 <input type="checkbox"/>
				Addresses not defined as registers are reserved for future expansion. The operation is undefined and not guaranteed when these addresses are accessed.	p. 95 <input type="checkbox"/>
			Programmable peripheral I/O area	The internal ROM/RAM area and on-chip peripheral I/O area are assigned to successive addresses. When accessing the internal ROM/RAM area by incrementing or decrementing addresses using pointer operations and such, therefore, be careful not to access the on-chip peripheral I/O area by mistakenly extending over the internal ROM/RAM area boundary.	p. 95 <input type="checkbox"/>
Programmable peripheral I/O area	The programmable peripheral I/O area exists only in the CAN controller versions. This area cannot be used with products that are not equipped with the CAN controller.	p. 95 <input type="checkbox"/>			

Chapter	Classification	Function	Details of Function	Cautions	Page
Chapter 3	Soft	CPU function	Expanded internal RAM	When using the external memory and expanded internal RAM simultaneously, set the external bus interface and expanded internal RAM at the same time.	p. 96 <input type="checkbox"/>
				When accessing the expanded internal RAM, all the external bus interface control signals except the $\overline{CSn}$ signal become active (n = 1 to 3). Therefore, when using the expanded internal RAM and external memory at the same time, be sure to control access to the external memory by using the $\overline{CSn}$ signal output from the chip.	p. 96 <input type="checkbox"/>
				If an external wait is inserted via the $\overline{WAIT}$ pin, an external wait will also be inserted into expanded internal RAM access.	p. 96 <input type="checkbox"/>
				Be sure to specify the initial settings for the expanded internal RAM before using it.	p. 96 <input type="checkbox"/>
			PRDSELH, PRDSELL registers	This register cannot be read by the in-circuit emulator (QB-V850ESX3H) (an undefined value is read).	p. 99 <input type="checkbox"/>
			BPC register	When setting the PA15 bit to 1, be sure to set the BPC register to 8FFBH. When clearing the PA15 bit to 0, be sure to set the BPC register to 0000H.	p. 123 <input type="checkbox"/>
			Setting data to special registers	Five NOP instructions or more must be inserted immediately after setting the IDLE1 mode, IDLE2 mode, or STOP mode (by setting the PSC.STP bit to 1).	p. 125 <input type="checkbox"/>
				When a store instruction is executed to store data in the command register, interrupts are not acknowledged. For details, see 3.4.8 (1) Caution 1.	p. 125 <input type="checkbox"/>
				Although dummy data is written to the PRCMD register, use the same general-purpose register used to set the special register (<4> in Example) to write data to the PRCMD register (<3> in Example). The same applies when a general-purpose register is used for addressing.	p. 125 <input type="checkbox"/>
			Registers to be set first	Be sure to set the following registers first. <ul style="list-style-type: none"> <li>• System wait control register (VSWC)</li> <li>• On-chip debug mode register (OCDM)</li> <li>• Watchdog timer mode register 2 (WDTM2)</li> <li>• Registers related to expanded internal RAM <ul style="list-style-type: none"> <li>• Bus size configuration register (BSC)</li> <li>• Data wait control register 1 (DWC1)</li> <li>• Address wait control register (AWC)</li> <li>• Bus cycle control register (BCC)</li> </ul> </li> <li>• Program ID register (ASID)</li> <li>• Initialization setting registers when using clock modes 2, 3, and 4 <ul style="list-style-type: none"> <li>• Clock control register (CKC)</li> <li>• SSCG frequency control register 0 (SFC0)</li> <li>• SSCG frequency control register 1 (SFC1)</li> </ul> </li> </ul>	p. 128 <input type="checkbox"/>
			VSWC register	Three clocks are required to access an on-chip peripheral I/O register (without a wait cycle). The V850E/SJ3-H and V850E/SK3-H require wait cycles according to the operating frequency. Set the following value to the VSWC register in accordance with the frequency used.	p. 128 <input type="checkbox"/>
			WDTM2 register	The watchdog timer 2 automatically starts in the reset mode after reset is released. Write the WDTM2 register to activate this operation.	p. 128 <input type="checkbox"/>
			Related to the expanded internal RAM registers	The expanded internal RAM is accessed via the external bus interface. Before accessing the expanded internal RAM, be sure to set the registers related to the external bus interface (initial settings for the expanded internal RAM).	p. 129 <input type="checkbox"/>

Chapter	Classification	Function	Details of Function	Cautions	Page	
Chapter 3	Soft	CPU function	Accessing specific on-chip peripheral I/O registers	When specific on-chip peripheral I/O registers are accessed, more wait states may be required in addition to the wait states set by the VSWC register.	p. 129 <input type="checkbox"/>	
				Accessing the above registers is prohibited in the following statuses. If a wait cycle is generated, it can only be cleared by a reset. <ul style="list-style-type: none"> <li>• When the CPU operates with the subclock and the main clock oscillation is stopped</li> <li>• When the CPU operates with the internal oscillation clock</li> </ul>	p. 131 <input type="checkbox"/>	
Chapter 4	Hard, soft	Port functions	Port 0	The $\overline{DRST}$ pin is for on-chip debugging. If on-chip debugging is not used, fix the P05/INTP2/ $\overline{DRST}$ pin to low level between when the reset signal of the RESET pin is released and when the OCDM.OCDM0 bit is cleared (0). For details, see 4.6.3 Cautions on on-chip debug pins.	p. 141 <input type="checkbox"/>	
				PMC0 register	The P05/INTP2/ $\overline{DRST}$ pin becomes the $\overline{DRST}$ pin regardless of the value of the PMC05 bit when the OCDM.OCDM0 bit = 1.	p. 142 <input type="checkbox"/>
				PF0 register	To pull up an output pin at $EV_{DD}$ or higher, be sure to set the appropriate PF0n bit to 1.	p. 144 <input type="checkbox"/>
				P1 register	Do not read/write the P1 register during D/A conversion (see 15.4.3 Cautions).	p. 145 <input type="checkbox"/>
				PM1 register	When using P1n as alternate functions (ANOn pin output), set the PM1n bit to 1.	p. 145 <input type="checkbox"/>
					When using one of the PM10 and PM11 pins as an I/O port and the other as a D/A output pin, do so in an application where the port I/O level does not change during D/A output.	p. 145 <input type="checkbox"/>
				PF2 register	To pull up an output pin at $EV_{DD}$ or higher, be sure to set the appropriate PF2n bit to 1.	p. 147 <input type="checkbox"/>
				P3 register	P312 to P310 bits are valid for the V850E/SK3-H only. Be sure to clear this bit to 0 in the V850E/SJ3-H. However, the read value becomes undefined.	p. 149 <input type="checkbox"/>
					Be sure to clear bits 13 to 15 to "0".	p. 149 <input type="checkbox"/>
				PM3 register	PM312 to PM310 bits are valid for the V850E/SK3-H only. Be sure to set this bit to 1 in the V850E/SJ3-H.	p. 150 <input type="checkbox"/>
					Be sure to set bits 13 to 15 to "1".	p. 150 <input type="checkbox"/>
				PMC3 register	PMC312 to PMC310 bits are valid for the V850E/SK3-H only. Be sure to clear this bit to 0 in the V850E/SJ3-H.	p. 151 <input type="checkbox"/>
					Be sure to clear bits 13 to 15 to "0".	p. 151 <input type="checkbox"/>
				PFC3 register	PFC310 bit is valid for the V850E/SK3-H only. Be sure to clear this bit to 0 in the V850E/SJ3-H.	p. 153 <input type="checkbox"/>
					Be sure to clear bits 11 to 15 to "0".	p. 153 <input type="checkbox"/>
PFCE3 register	PFCE310 bit is valid for the V850E/SK3-H only. Be sure to clear this bit to 0 in the V850E/SJ3-H.	p. 153 <input type="checkbox"/>				
	Be sure to clear bits 0, 1, 5 to 7, and 11 to 15 to "0".	p. 153 <input type="checkbox"/>				
Port 3 alternate function specifications	The INTP7 pin and RXDA0 pin are alternate-function pins. When using the pin as the RXDA0 pin, disable edge detection for the INTP7 alternate-function pin. (Clear the INTF3.INTF31 bit and the INTR3.INTR31 bit to 0.) When using the pin as the INTP7 pin, stop UARTA0 reception. (Clear the UA0CTL0.UA0RXE bit to 0.)	p. 155 <input type="checkbox"/>				
PF3 register	PF312 to PF310 bits are valid for the V850E/SK3-H only. Be sure to clear this bit to 0 in the V850E/SJ3-H.	p. 156 <input type="checkbox"/>				
	To pull up an output pin at $EV_{DD}$ or higher, be sure to set the appropriate PF3n bit to 1.	p. 156 <input type="checkbox"/>				
	Be sure to clear bits 13 to 15 to "0".	p. 156 <input type="checkbox"/>				

Chapter	Classification	Function	Details of Function	Cautions	Page	
Chapter 4	Soft	Port functions	P4 register	P45 to P43 bits are valid for the V850E/SK3-H only. Be sure to clear this bit to 0 in the V850E/SJ3-H. However, the read value becomes undefined.	p. 158 <input type="checkbox"/>	
				Be sure to clear bits 6 and 7 to "0".	p. 158 <input type="checkbox"/>	
			PM4 register	PM45 to PM43 bits are valid for the V850E/SK3-H only. Be sure to set this bit to 1 in the V850E/SJ3-H.	p. 158 <input type="checkbox"/>	
				Be sure to set bits 6 and 7 to "1".	p. 158 <input type="checkbox"/>	
			PMC4 register	PMC45 to PMC44 bits are valid for the V850E/SK3-H only. Be sure to clear this bit to 0 in the V850E/SJ3-H.	p. 159 <input type="checkbox"/>	
				Be sure to clear bits 3, 6 and 7 to "0".	p. 159 <input type="checkbox"/>	
			PFC4 register	Be sure to clear bits 3 to 7 to "0".	p. 160 <input type="checkbox"/>	
			PF4 register	PF45 to PF43 bits are valid for the V850E/SK3-H only. Be sure to clear this bit to 0 in the V850E/SJ3-H.	p. 160 <input type="checkbox"/>	
				To pull up an output pin at EV <sub>DD</sub> or higher, be sure to set the appropriate PF4n bit to 1.	p. 160 <input type="checkbox"/>	
				Be sure to clear bits 6 and 7 to "0".	p. 160 <input type="checkbox"/>	
			Hard, soft	Port 5	The DDI, DDO, DCK, and DMS pins are for on-chip debugging. If on-chip debugging is not used, fix the P05/INTP2/ $\overline{DRST}$ pin to low level between when the reset signal of the $\overline{RESET}$ pin is released and when the OCDM.OCDM0 bit is cleared (0). For details, see 4.6.3 Cautions on on-chip debug pins.	p. 161 <input type="checkbox"/>
					When the power is turned on, the P53 pin may momentarily output an undefined level.	p. 161 <input type="checkbox"/>
	Soft		P5 register	P57 and P56 bits are valid for the V850E/SK3-H only. Be sure to clear this bit to 0 in the V850E/SJ3-H. However, the read value becomes undefined.	p. 162 <input type="checkbox"/>	
			PM5 register	PM57 and PM56 bits are valid for the V850E/SK3-H only. Be sure to set this bit to 1 in the V850E/SJ3-H.	p. 162 <input type="checkbox"/>	
			PMC5 register	PMC57 and PMC56 bits are valid for the V850E/SK3-H only. Be sure to clear this bit to 0 in the V850E/SJ3-H.	p. 163 <input type="checkbox"/>	
			Port 5 alternate function specifications	The KRn pin and TIQ0m pin are alternate-function pins. When using the pin as the TIQ0m pin, disable KRn pin key return detection, which is the alternate function. (Clear the KRM.KRMn bit to 0.) Also, when using the pin as the KRn pin, disable TIQ0m pin edge detection, which is the alternate function (n = 0 to 3, m = 0 to 3).	p. 165 <input type="checkbox"/>	
			PF5 register	PF57 and PF56 bits are valid for the V850E/SK3-H only. Be sure to clear this bit to 0 in the V850E/SJ3-H.	p. 166 <input type="checkbox"/>	
				To pull up an output pin at EV <sub>DD</sub> or higher, be sure to set the appropriate PF5n bit to 1.	p. 166 <input type="checkbox"/>	
			PFC6 register	The PFC62 bit is not available in the $\mu$ PD70F3931 (V850E/SJ3-H), 70F3932 (V850E/SJ3-H), and 70F3933 (V850E/SJ3-H). Be sure to clear this bit to 0 in the $\mu$ PD70F3931 (V850E/SJ3-H), 70F3932 (V850E/SJ3-H), and 70F3933 (V850E/SJ3-H).	p. 171 <input type="checkbox"/>	
				Be sure to clear bit 15 to "0".	p. 171 <input type="checkbox"/>	
			PFCE6 register	The PFCE68, PECE67, and PFCE62 to PFCE60 bits are not available in the $\mu$ PD70F3931 (V850E/SJ3-H), 70F3932 (V850E/SJ3-H), and 70F3933 (V850E/SJ3-H) only. Be sure to clear this bit to 0 in the $\mu$ PD70F3931 (V850E/SJ3-H), 70F3932 (V850E/SJ3-H), and 70F3933 (V850E/SJ3-H).	p. 171 <input type="checkbox"/>	
				Be sure to clear bit 15 to "0".	p. 171 <input type="checkbox"/>	

Chapter	Classification	Function	Details of Function	Cautions	Page	
Chapter 4	Soft	Port functions	Port 6 alternate function specifications	The KRn pin and TIQ0m pin are alternate-function pins. When using the pin as the TIQ0m pin, disable KRn pin key return detection, which is the alternate function. (Clear the KRM.KRMn bit to 0.) Also, when using the pin as the KRn pin, disable TIQ0m pin edge detection, which is the alternate function (n = 2, 3, m = 0, 3).	p. 174	<input type="checkbox"/>
			PF6 register	To pull up an output pin at EV <sub>DD</sub> or higher, be sure to set the appropriate PF6n bit to 1.	p. 174	<input type="checkbox"/>
			P7H register, P7L register	Do not read/write the P7H and P7L registers during A/D conversion (see 13.6 (4) Alternate I/O).	p. 176	<input type="checkbox"/>
			PM7H register, PM7L register	When using the P7n pin as its alternate function (ANIn pin), set the PM7n bit to 1.	p. 176	<input type="checkbox"/>
			P8 register	P85 to P82 bits are valid for the V850E/SK3-H only. Be sure to clear this bit to 0 in the V850E/SJ3-H. However, the read value becomes undefined.	p. 177	<input type="checkbox"/>
				Be sure to clear bits 6 and 7 to "0".	p. 177	<input type="checkbox"/>
			PM8 register	PM85 to PM82 bits are valid for the V850E/SK3-H only. Be sure to set this bit to 1 in the V850E/SJ3-H.	p. 178	<input type="checkbox"/>
				Be sure to set this bit to 1 in the V850E/SJ3-H.	p. 178	<input type="checkbox"/>
			PMC8 register	PMC85 to PMC82 bits are valid for the V850E/SK3-H only. Be sure to clear this bit to 0 in the V850E/SJ3-H.	p. 179	<input type="checkbox"/>
				The INTP8 and RXDA3 pins are alternate-function pins. When using the RXDA3 pin, disable detection of the edge of the INTP8 pin (INTF8.INTF80 bit = 0 and INTR8.INTR80 bit = 0). When using the INTP8 pin, stop the reception operation of UARTA3 (UA3CTL0.UA3RXE bit = 0).	p. 179	<input type="checkbox"/>
				Be sure to clear bits 6 and 7 to "0".	p. 179	<input type="checkbox"/>
			PF8 register	PF85 to PF82 bits are valid for the V850E/SK3-H only. Be sure to clear this bit to 0 in the V850E/SJ3-H.	p. 181	<input type="checkbox"/>
				To pull up an output pin at EV <sub>DD</sub> or higher, be sure to set the appropriate PF8n bit to 1.	p. 181	<input type="checkbox"/>
				Be sure to clear bits 6 and 7 to "0".	p. 181	<input type="checkbox"/>
			PMC9 register	Port 9 pins cannot be used as port pins or other alternate-function pins if even one of the A0 to A15 pins is used in the separate bus mode. After setting the PFC9 and PFCE9 registers to 0000H, therefore, set all 16 bits of the PMC9 register to FFFFH at once. If none of the A0 to A15 pins is used in the separate bus mode, port 9 pins can be used as port pins or other alternate-function pins.	p. 185	<input type="checkbox"/>
			PFC9 register	Port 9 pins cannot be used as port pins or other alternate-function pins if even one of the A0 to A15 pins is used in the separate bus mode. After setting the PFC9 and PFCE9 registers to 0000H, therefore, set all 16 bits of the PMC9 register to FFFFH at once. If none of the A0 to A15 pins is used in the separate bus mode, port 9 pins can be used as port pins or other alternate-function pins.	p. 186	<input type="checkbox"/>
			Port 9 alternate function specifications	The RXDA1 and KR7 pins must not be used at the same time. When using the RXDA1 pin, do not use the KR7 pin (clear the KRM.KRM7 bit to 0). When using the KR7 pin, do not use the RXDA1 pin (it is recommended to set the PFC91 bit to 1 and clear the PFCE91 bit to 0). When the PFC91 bit is cleared to 0 and the PFCE91 bit is set to 1, clear the UA1CTL0.UA1RXE bit to 0.	p. 188	<input type="checkbox"/>
PF9 register	To pull up an output pin at EV <sub>DD</sub> or higher, be sure to set the appropriate PF9n bit to 1.	p. 189	<input type="checkbox"/>			
P13 register	Be sure to clear bits 4 to 7 to "0".	p. 190	<input type="checkbox"/>			
PM13 register	Be sure to set bits 4 to 7 to "1".	p. 190	<input type="checkbox"/>			
P14 register	Be sure to clear bits 6 and 7 to "0".	p. 191	<input type="checkbox"/>			
PM14 register	Be sure to set bits 6 and 7 to "1".	p. 191	<input type="checkbox"/>			



Chapter	Classification	Function	Details of Function	Cautions	Page
Chapter 4	Soft	Port functions	P15 register	Be sure to clear bits 4 to 7 to "0".	p. 192 <input type="checkbox"/>
			PM15 register	Be sure to set bits 4 to 7 to "1".	p. 192 <input type="checkbox"/>
			PMC15 register	Be sure to clear bits 4 to 7 to "0".	p. 193 <input type="checkbox"/>
				The RXDA1 and KR7 pins must not be used at the same time. When using the RXDA1 pin, do not use the KR7 pin (clear the KRM.KRM7 bit to 0). When using the KR7 pin, do not use the RXDA1 pin (clear the UA1CTL0.UA1RXE bit to 0).	p. 193 <input type="checkbox"/>
			PF15 register	To pull up an output pin at EV <sub>DD</sub> or higher, be sure to set the appropriate PF15n bit to 1.	p. 193 <input type="checkbox"/>
				Be sure to clear bits 4 to 7 to "0".	p. 193 <input type="checkbox"/>
			PCD register	Be sure to clear bits 4 to 7 to "0".	p. 194 <input type="checkbox"/>
			PMCD register	Be sure to set bits 4 to 7 to "1".	p. 194 <input type="checkbox"/>
			PMCCD register	Be sure to clear bits 4 to 7 to "0".	p. 195 <input type="checkbox"/>
			PFCCD register	Be sure to clear bits 4 to 7 to "0".	p. 195 <input type="checkbox"/>
			PMCCS register	Be sure to clear bits 0 and 4 to 7 to "0".	p. 199 <input type="checkbox"/>
	PMCDL register	When the EXIMC.SMSEL bit = 1 (separate mode) and the BSC.BS30 to BSC.BS00 bits = 0 (8-bit bus width), do not specify the AD8 to AD15 pins.	p. 206 <input type="checkbox"/>		
	Hard	Port register settings when alternate function is used	Between the P10 and P11 pins, when one pin is used as the I/O port, and the other pin is used as the D/A output pin (ANO0, ANO1), make sure that the port I/O level does not change during D/A output.	p. 271 <input type="checkbox"/>	
	Soft	Cautions on switching from port mode to alternate-function mode	To switch from the port mode to alternate-function mode in the following order. <1> Set the PFn register <sup>Note</sup> : N-ch open-drain setting <2> Set the PFCn and PFCEn registers: Alternate-function selection <3> Set the corresponding bit of the PMCn register to 1: Switch to alternate-function mode If the PMCn register is set first, note with caution that, at that moment or depending on the change of the pin states in accordance with the setting of the PFn, PFCn, and PFCEn registers, unexpected operations may occur.	p. 284 <input type="checkbox"/>	
Regardless of the port mode/alternate-function mode, the Pn register is read and written as follows. • Pn register read: Read the port output latch value (when PMn.PMnm bit = 0), or read the pin states (PMn.PMnm bit = 1). • Pn register write: Write to the port output latch			p. 284 <input type="checkbox"/>		
Cautions on alternate-function mode (input)		Switch between the port mode and alternate-function mode in the following sequence. • To switch from port mode to alternate-function mode (input) Set the pins to the alternate-function mode using the PMCn register and then enable the alternate-function operation. • To switch from alternate-function mode (input) to port mode Stop the alternate-function operation and then switch the pins to the port mode.	p. 285 <input type="checkbox"/>		
In port mode, PFn.PFnm bit		In port mode, the PFn.PFnm bit is valid only in the output mode (PMn.PMnm bit = 0). In the input mode (PMnm bit = 1), the value of the PFnm bit is not reflected in the buffer.	p. 286 <input type="checkbox"/>		
Cautions on bit manipulation instruction for port n register (Pn)		When a 1-bit manipulation instruction is executed on a port that provides both input and output functions, the value of the output latch of an input port that is not subject to manipulation may be written in addition to the targeted bit. Therefore, it is recommended to rewrite the output latch when switching a port from input mode to output mode.	p. 287 <input type="checkbox"/>		

Chapter	Chapter Classification	Function	Details of Function	Cautions	Page		
Chapter 4	Hard, soft	Port functions	Cautions on on-chip debug pins	The following action must be taken if on-chip debugging is not used. <ul style="list-style-type: none"> <li>Clear the OCDM0 bit of the OCDM register (special register) (0)</li> </ul> At this time, fix the P05/INTP2/ $\overline{\text{DRST}}$ pin to low level from when reset by the $\overline{\text{RESET}}$ pin is released until the above action is taken. If a high level is input to the $\overline{\text{DRST}}$ pin before the above action is taken, it may cause a malfunction (CPU deadlock). Handle the P05 pin with the utmost care.	p. 288 <input type="checkbox"/>		
				The P05/INTP2/ $\overline{\text{DRST}}$ pin is not initialized to function as an on-chip debug pin ( $\overline{\text{DRST}}$ ) when a reset signal (WDT2RES) is generated due to a watchdog timer overflow, a reset signal (LVRES) is generated by the low-voltage detector (LVI), or a reset signal (CLMRES) is generated by the clock monitor (CLM). The OCDM register holds the current value.	p. 288 <input type="checkbox"/>		
				Cautions on P05/INTP2/ $\overline{\text{DRST}}$ pin	The P05/INTP2/ $\overline{\text{DRST}}$ pin has an internal pull-down resistor (30 k $\Omega$ TYP.). After a reset by the $\overline{\text{RESET}}$ pin, a pull-down resistor is connected. The pull-down resistor is disconnected when the OCDM0 bit is cleared (0).	p. 288 <input type="checkbox"/>	
				Cautions on P53 pin when power is turned on	When the power is turned on, the following pins may momentarily output an undefined level. <ul style="list-style-type: none"> <li>P53/SIB2/KR3/TIQ00/TOQ00/RTP03/DDO pin</li> </ul>	p. 288 <input type="checkbox"/>	
				Hysteresis characteristics	In port mode, the following port pins do not have hysteresis characteristics. P00 to P06 P20 <sup>Note</sup> , P21 <sup>Note</sup> P31 to P35, P37 to P39, P312 <sup>Note</sup> P40 to P42, P45 <sup>Note</sup> P50 to P55, P56 <sup>Note</sup> P60, P62 to P615 P80, P82 to P84 <sup>Note</sup> P90 to P97, P99, P910, P912 to P915 P150 <sup>Note</sup> , P152 <sup>Note</sup> , P153 <sup>Note</sup> PCD0, PCD2 <b>Note</b> V850E/SK3-H only	p. 288 <input type="checkbox"/>	
	Soft				Cautions on separate bus mode	Port 9 pins cannot be used as port pins or other alternate-function pins if even one of the A0 to A15 pins is used in the separate bus mode. After setting the PFC9 and PFCE9 registers to 0000H, therefore, set all 16 bits of the PMC9 register to FFFFH at once. If none of the A0 to A15 pins is used in the separate bus mode, port 9 pins can be used as port pins or other alternate-function pins.	p. 289 <input type="checkbox"/>
					Cautions on reading port n registers (Pn: n = 3 to 5, 8) (V850E/SJ3-H only)	In the V850E/SJ3-H, the bit values of the following port n registers become undefined when read. Port 3 register: P310 to P312 Port 4 register: P43 to P45 Port 5 register: P56, P57 Port 8 register: P82 to P85	p. 289 <input type="checkbox"/>
					Cautions on setting port n mode control registers (PMcn: n = 3 to 5, 8)	In the V850E/SJ3-H, be sure to set the bits of the following port n mode control registers to 0. Port 3 mode control register: PMC310 to PMC312 Port 4 mode control register: PMC44, PMC45 Port 5 mode control register: PMC56, PMC57 Port 8 mode control register: PMC82 to PMC85	p. 289 <input type="checkbox"/>

Chapter	Classification	Function	Details of Function	Cautions	Page
Chapter 5	Soft	Bus control function	Pin status when internal ROM	When the internal ROM is written, as well as when the external memory area is accessed, the address bus, address/data bus, and control signals are activated, but write access is prohibited.	p. 292 <input type="checkbox"/>
			Pin status when the expanded internal RAM is accessed	When the expanded internal RAM is accessed, control signals ( $\overline{RD}$ , $\overline{WR0}$ , $\overline{WR1}$ , $\overline{ASTB}$ ) are activated. Therefore, accesses to the external memory or external I/O must be controlled by the $\overline{CSn}$ signal (n = 1 to 3).	p. 292 <input type="checkbox"/>
			CSC0 and CSC1 registers	Write to the CSC0 and CSC1 registers after reset, and then do not change the set values. Also, do not access an external memory area until the initial settings of the CSC0 and CSC1 registers are complete.	p. 296 <input type="checkbox"/>
				In the $\mu$ PD70F3931 (V850E/SJ3-H), 70F3932 (V850E/SJ3-H), and 70F3933 (V850E/SJ3-H), expanded internal RAM is not provided. Therefore, the setting shown in "5.3.1 (1) (a) When using expanded internal RAM" cannot be used. Be sure to use the setting shown in "5.3.1 (1) (b) When not using expanded internal RAM".	p. 296 <input type="checkbox"/>
			EXIMC register	Write to the EXIMC register after reset, and then do not change the set values. Also, do not access an external memory area until the initial settings of the EXIMC register are complete.	p. 301 <input type="checkbox"/>
				Set the EXIMC register from the internal ROM or internal RAM area before making an external access.	p. 301 <input type="checkbox"/>
				After setting the EXIMC register, be sure to insert a NOP instruction.	
			BSC register	Write to the BSC register after reset, and then do not change the set values. Also, do not access an external memory area until the initial settings of the BSC register are complete.	p. 303 <input type="checkbox"/>
				Be sure to clear bits 7, 5, and 3 to "0".	p. 303 <input type="checkbox"/>
			DWC0, DWC1 registers	Write to the DWC0 and DWC1 registers after reset, and then do not change the set values. Also, do not access an external memory area until the initial settings of the DWC0 and DWC1 registers are complete.	pp. 311, 313 <input type="checkbox"/>
				When the V850E/SJ3-H and V850E/SK3-H are used in separate bus mode and operated at $f_{CPU} > 20$ MHz, be sure to insert one or more wait.	pp. 311, 313 <input type="checkbox"/>
				When the V850E/SJ3-H and V850E/SK3-H are used in multiplexed bus mode and operated at $f_{CPU} > 32$ MHz, be sure to insert one or more wait.	pp. 311, 313 <input type="checkbox"/>
			DWC0 register	Be sure to clear bits 15, 11, 7, and 3 to "0".	p. 312 <input type="checkbox"/>
			DWC1 register	In the $\mu$ PD70F3931 (V850E/SJ3-H), 70F3932 (V850E/SJ3-H), and 70F3933 (V850E/SJ3-H), expanded internal RAM is not provided. Therefore, the setting shown in "5.6.1 (2) (a) When using expanded internal RAM" cannot be used. Be sure to use setting shown in "5.6.1 (2) (b) Not using expansion internal RAM".	p. 312 <input type="checkbox"/>
				Be sure to clear bits 15, 11, 7, and 3 to "0", and set bits 14 to 12, 10 to 8, 2 to 0 to "1".	p. 313 <input type="checkbox"/>
AWC register	Write to the AWC register after reset, and then do not change the set values. Also, do not access an external memory area until the initial settings of the AWC register are complete.	p. 316 <input type="checkbox"/>			
	When the V850E/SJ3-H and V850E/SK3-H are operated at $f_{CPU} > 20$ MHz, be sure to insert the address hold wait and the address setup wait.	p. 316 <input type="checkbox"/>			
BCC register	Write to the BCC register after reset, and then do not change the set values. Also, do not access an external memory area until the initial settings of the BCC register are complete.	p. 318 <input type="checkbox"/>			
	Be sure to clear bits 6, 4, 2, and 0 to "0".	p. 318 <input type="checkbox"/>			

Chapter	Classification	Function	Details of Function	Cautions	Page
Chapter 6	Soft	Clock generation function	Clock mode	The clock mode is set using the option byte, and therefore cannot be switched during operation. Consequently, it is important to determine which clock mode is to be used, before starting operation.	p. 329 <input type="checkbox"/>
			Clock mode 1	In clock mode 1, the main clock ( $f_{xx}$ ) is supplied as the source of the peripheral clock ( $f_{XP}$ , $f_{IE}$ , $f_{CAN}$ ). In this mode, the SSCG output clock cannot be used as the main clock.	p. 330 <input type="checkbox"/>
				Enable operation of the on-chip peripheral functions that operate on the main clock (= peripheral clock) after ensuring that main clock oscillation is stable. If operation of these functions is enabled before the main clock's oscillation stabilization time has elapsed, a malfunction may occur.	p. 359 <input type="checkbox"/>
			Clock mode 2 to 4	In clock modes 3 and 4, the SSCG output clock is used as the main clock and the PLL output is used as the peripheral clock. In these modes, the PLL output clock cannot be used as the main clock. Also, when clock-through mode is selected for the main clock, the source of the peripheral clock will be the PLL output clock.	p. 331 <input type="checkbox"/>
				The PLL starts operating and enters the locked state after reset release (PLLCTL.PLLON bit = 1, LOCKR.LOCK bit = 0). Do not subsequently stop the PLL by software (i.e., do not set the PLLCTL.PLLON bit to 0). Under any of the following conditions, however, the PLL will stop automatically. <ul style="list-style-type: none"> <li>• When a system reset is applied</li> <li>• When the system enters IDLE2 or STOP mode</li> <li>• When the CPU is operating on the subclock and the main clock is stopped (PCC.CK3 bit = 1, PCC.MCK bit = 1)</li> </ul> The PLL starts operation again when the condition is released. Be sure to set the oscillation stabilization time and setup time to be inserted after conditions are released to over the lockup time of PLL.	pp. 335, 338, 341 <input type="checkbox"/>
				In clock modes 2, 3, and 4, the PLL output clock ( $f_{PLLO}$ ) cannot be selected as the main clock ( $f_{xx}$ ). However, when the SSCG is stopped by setting the SSCGCTL.SSCGON bit to 0, the SSCGCTL.SELSSCG bit automatically becomes 0, causing $f_{PLLO}$ to be selected as the main clock. Consequently, when switching from SSCG mode to clock-through mode, be sure to first set the PLLCTL.SELPLL bit to 0, and then stop the SSCG by setting the SSCGON bit to 0 after switching modes. Similarly, when switching from clock-through mode to SSCG mode, first set the SSCGON bit to 1 to start up the SSCG, wait for the lockup time to elapse, then set the SELSSCG bit to 1 to select $f_{SSCGO}$ before finally setting the SELPLL bit to 1.	pp. 335, 338, 341 <input type="checkbox"/>
				In clock mode 2 to 4, be sure to set the CKC.CKDIV0 bit to 1 (no division).	pp. 336, 339, 342 <input type="checkbox"/>
				In clock modes 2, 3, and 4, always set the CKC, SFC0 and SFC1 registers in the status immediately after reset release; that is, in clock-through mode (PLLCTL.SELPLL bit = 0) and with SSCG operation stopped.	p. 361 <input type="checkbox"/>
				Set the CKC, SFC0, and SFC1 registers only once after reset is released. These settings cannot be changed during operation.	p. 361 <input type="checkbox"/>
				Be sure to insert a 1 $\mu$ s wait time after setting the CKC, SFC0, and SFC1 registers.	p. 361 <input type="checkbox"/>
When the SSCGCTL.SSCGON bit is set to 0, the SSCGCTL.SELSSCG bit is also cleared to 0, automatically.	p. 362 <input type="checkbox"/>				
When switching the system to subclock operation, first switch to clock-through mode and stop operation of the SSCG.	p. 362 <input type="checkbox"/>				

Chapter	Classification	Function	Details of Function	Cautions	Page	
Chapter 6	Soft	Clock generation function	Clock mode 2 to 4	Do not stop operation of the PLL by software. When the main clock oscillator is stopped, the PLL automatically stops with the PLLCTL.PLLON bit still set to 1 (PLL operable). Do not clear (0) the PLLCTL.PLLON bit after stopping the PLL.	p. 362 <input type="checkbox"/>	
				Enable operation of the on-chip peripheral functions that operate on the peripheral clock ( $f_{XP}$ , $f_{IE}$ , and $f_{CAN}$ ) after ensuring that main clock oscillation is stable. If operation of these functions is enabled before the main clock's oscillation stabilization time has elapsed, a malfunction may occur.	p. 363 <input type="checkbox"/>	
				Enable operation of the SSCG after switching to main clock operation.	p. 363 <input type="checkbox"/>	
				Clock mode 4	In clock mode 4, be sure to set the PLLI0 bit of the option byte 0000007BH to 0 (no division).	p. 342 <input type="checkbox"/>
				PCC register	Do not change the CPU clock (by using the CK3 to CK0 bits) while CLKOUT is being output.	p. 346 <input type="checkbox"/>
			When manipulating the CK3 bit, do not change the set values of the CK2 to CK0 bits.		p. 346 <input type="checkbox"/>	
			When the main clock oscillator is stopped, be sure to stop operation of the on-chip peripheral functions that are operating on the peripheral clock ( $f_{XP}$ , $f_{IE}$ , $f_{CAN}$ ).		p. 346 <input type="checkbox"/>	
			If the following condition is not satisfied, make sure to satisfy it by changing the CK2 to CK0 bit settings before shifting to subclock operation mode. Internal system clock ( $f_{CLK}$ ) > Subclock ( $f_{XT}$ : 32.768 kHz) × 4		p. 346 <input type="checkbox"/>	
				RCM register	The internal oscillator cannot be stopped while the CPU is operating on the internal oscillation clock (CCLS.CCLSF bit = 1). Do not set the RSTOP bit to 1.	p. 347 <input type="checkbox"/>
			The internal oscillator oscillates if the CCLS.CCLSF bit is set to 1 (when WDT overflow occurs during oscillation stabilization) even when the RSTOP bit is set to 1. At this time, the RSTOP bit remains being set to 1.		p. 347 <input type="checkbox"/>	
			The setting of the RSTOP bit is only valid when stopping the on-chip oscillator has been enabled by setting the RMOPIN bit of the option byte 0000007AH (see CHAPTER 33 OPTION BYTE FUNCTION for details) to 0. If stopping the on-chip oscillator has been disabled by setting the RMOPIN bit of the option byte 0000007AH to 1, the RSTOP bit setting is invalid.		p. 347 <input type="checkbox"/>	
			Be sure to set bits 1 to 7 to "0".		p. 347 <input type="checkbox"/>	
				PLLCTL register	In clock modes 2, 3, and 4, do not stop the PLL by software (i.e., do not set the PLLCTL.PLLON bit to 0).	p. 348 <input type="checkbox"/>
			When stopping PLL operation in clock mode 1, first set the clock through mode (SELPLL bit = 0), wait for at least 8 clocks, and then stop the PLL (PLLON bit = 0). When the PLLON bit is cleared to 0, the SELPLL bit is automatically cleared to 0 (clock-through mode), but be sure to stop the PLL in the above procedure.		p. 348 <input type="checkbox"/>	
			When stopping SSCG operation in clock modes 2, 3, and 4, first set the clockthrough mode (SELPLL bit = 0), then stop the SSCG (by setting the SSCGCTL.SSCGON bit to 0) after waiting for at least 8 clocks to elapse.		p. 348 <input type="checkbox"/>	
			Set the SELPLL bit to 1 after the PLL clock frequency or SSCG clock frequency has stabilized (locked state). If the PLL frequency is not stable (LOCKR.LOCK bit = 1 (unlocked state)), even if 1 is written to the SELPLL bit, 0 will end up being written. Also, be sure to properly secure the SSCG lockup time by software.		p. 348 <input type="checkbox"/>	
				CKC register	The CKC.CKDIV0 bit can be switched in clock mode 1. However, when setting the CKDIV0 bit, be sure to set the clock-through mode and stop the PLL.	p. 349 <input type="checkbox"/>

Chapter	Classification	Function	Details of Function	Cautions	Page
Chapter 6	Soft	Clock generation function	CKC register	In clock modes 2, 3, and 4, be sure to set the CKDIV0 bit to 1 (no division) immediately after reset is released, while the clock modes are still in clock-through mode (PLLCTL.SELPLL bit = 0). Set the CKC register only once after reset is released. These settings cannot be changed during operation. For details of the initial settings, see 6.4.4 (1) Initial settings for using clock modes 2, 3, and 4.	p. 349 <input type="checkbox"/>
				Be sure to set bits 1 and 3 to "1" and set bits 2 and 4 to 7 to "0".	p. 349 <input type="checkbox"/>
			LOCKR register	The LOCK register does not reflect the lock status of the PLL in real time.	p. 350 <input type="checkbox"/>
			PLLS register	Set so that the lockup time is 800 $\mu$ s or longer.	p. 351 <input type="checkbox"/>
				Do not change the PLLS register setting during the lockup period.	p. 351 <input type="checkbox"/>
				Be sure to set bits 2 to 7 to "0".	p. 351 <input type="checkbox"/>
			SSCGCTL register	The SSCG cannot be used in clock mode 1. Do not change the initial settings of the SSCGCTL register in this mode.	p. 352 <input type="checkbox"/>
				In clock modes 2, 3, and 4, the PLL output clock ( $f_{PLLO}$ ) cannot be selected for the multiplication clock ( $f_{PLL}$ ). However, when the SSCG is stopped by setting the SSCGCTL.SSCGON bit to 0, the SSCGCTL.SELSSCG bit automatically becomes 0, causing $f_{PLLO}$ to be selected as the multiplication clock. Consequently, when switching from SSCG mode to clock-through mode, be sure to first set the PLLCTL.SELPLL bit to 0, and then stop the SSCG by setting the SSCGON bit to 0 after switching modes. Similarly, when switching from clock-through mode to SSCG mode, first set the SSCGON bit to 1 to start up the SSCG, wait for the lockup time to elapse, then set the SELSSCG bit to 1 to select $f_{SSCG0}$ before finally setting the SELPLL bit to 1.	p. 352 <input type="checkbox"/>
				When the PLL is stopped (PLLCTL.PLLON bit = 0), the SSCG will not operate even if the SSCGCTL.SSCGON bit is set to 1. Note, however, that the PLL cannot be stopped in clock modes 2, 3, and 4.	p. 352 <input type="checkbox"/>
				Be sure to set bits 2 to 7 to "0".	p. 352 <input type="checkbox"/>
			SFC0 register	The SSCG cannot be used in clock mode 1. Do not change the initial settings of the SFC0 register in this mode.	p. 353 <input type="checkbox"/>
				In clock modes 2, 3, and 4, be sure to make the SFC0 register settings immediately after reset is released, while the clock modes are still in clock-through mode (PLLCTL.SELPLL bit = 0) and the SSCG is stopped (SSCGCTL.SSCGON bit = 0). In addition, be sure to set the SFC0 register only once after reset is released. These settings cannot be changed during operation. For details, see 6.4.4 (1) Initial settings for using clock modes 2, 3, and 4.	p. 353 <input type="checkbox"/>
			SFC1 register	The SSCG cannot be used in clock mode 1. Do not change the initial settings of the SFC1 register in this mode.	p. 354 <input type="checkbox"/>
				In clock modes 2, 3, and 4, be sure to make the SFC1 register settings immediately after reset is released, while the clock modes are still in clock-through mode (PLLCTL.SELPLL bit = 0) and the SSCG is stopped (SSCGCTL.SSCGON bit = 0). In addition, be sure to set the SFC1 register only once after reset is released. These settings cannot be changed during operation. For details, see 6.4.4 (1) Initial settings for using clock modes 2, 3, and 4.	p. 354 <input type="checkbox"/>
Be sure to set bits 2, 3, and 6 to "0".	p. 354 <input type="checkbox"/>				
Procedure for setting clock generation function for using clock mode 1	Set the clock generation function in accordance with 6.4.3 Procedure for setting clock generation function for using clock mode 1	p. 357 <input type="checkbox"/>			

Chapter	Classification	Function	Details of Function	Cautions	Page
Chapter 6	Soft	Clock generation function	Procedure for setting clock generation function for using clock modes 2, 3, and 4	Set the clock generation function in accordance with 6.4.4 Procedure for setting clock generation function for using clock modes 2, 3, and 4	p. 360 <input type="checkbox"/>
Chapter 7	Soft	16-bit timer/event counter P (TMP)	TP0CTL0 to TP8CTL0 registers	Set the TPnCKS2 to TPnCKS0 bits when the TPnCE bit = 0.	p. 373 <input type="checkbox"/>
				When the value of the TPnCE bit is changed from 0 to 1, the TPnCKS2 to TPnCKS0 bits can be set simultaneously. Be sure to clear bits 3 to 6 to "0".	p. 373 <input type="checkbox"/>
			TP0CTL1 to TP8CTL1 registers	Set the TPnEEE and TPnMD3 to TPnMD0 bits when the TPnCTL0.TPnCE bit = 0. (The same value can be written when the TPnCE bit = 1.) The operation is not guaranteed when rewriting is performed with the TPnCE bit = 1. If rewriting was mistakenly performed, clear the TPnCE bit to 0 and then set the bits again.	p. 375 <input type="checkbox"/>
				Be sure to clear bits 3, 4, and 7 to "0" for TMP0 to TMP6 and bits 4 and 7 to "0" for TMP7 and TMP8.	p. 375 <input type="checkbox"/>
			TP7CTL2 to TP8CTL2 registers	The TPmLDE bit is valid only when the TPmECM1 and TPmECM0 bits = 00, 01. Writing "1" to this bit is ignored when the TPmECM1 and TPmECM0 bits = 10, 11.	p. 377 <input type="checkbox"/>
				The edge detection of the TENCm0 and TENCm1 inputs specified by the TPmIOC3.TPmEIS1 and TPmIOC3.TPmEIS0 bits is invalid and fixed to both the rising and falling edges when the TPmUDS1 and TPmUDS0 bits = 10, 11.	p. 377 <input type="checkbox"/>
				Set the TPmLDE, TPmECM1, TPmECM0, TPmUDS1, and TPmUDS0 bits when the TPmCTL0.TPnCE bit = 0 (the same value can be written to these bits when the TPnCE bit = 1). If the value of these bits is changed when the TPnCE bit = 1, the operation cannot be guaranteed. If it is changed by mistake, clear the TPnCE bit and then set the correct value. Be sure to clear bits 5 and 6 to "0".	p. 377 <input type="checkbox"/>
			TP0IOC0 to TP8IOC0 registers	The pin output changes if the setting of the TPnIOC0 register is rewritten when the port is set to TOPn0 and TOPn1 outputs. Therefore, note changes in the pin status by setting the port to the input mode and making the output status of the pins a high-impedance state.	p. 379 <input type="checkbox"/>
				Rewrite the TPnOL1, TPnOE1, TPnOL0, and TPnOE0 bits when the TPnCTL0.TPnCE bit = 0. (The same value can be written when the TPnCE bit = 1.) If rewriting was mistakenly performed, clear the TPnCE bit to 0 and then set the bits again.	p. 379 <input type="checkbox"/>
				Even if the TPnOLa bit is manipulated when the TPnCE and TPnOEa bits are 0, the TOPna pin output level varies (a = 0, 1).	p. 379 <input type="checkbox"/>
			TP0IOC1 to TP8IOC1 registers	Rewrite the TPnIS3 to TPnIS0 bits when the TPnCTL0.TPnCE bit = 0. (The same value can be written when the TPnCE bit = 1.) If rewriting was mistakenly performed, clear the TPnCE bit to 0 and then set the bits again.	p. 380 <input type="checkbox"/>
				Be sure to clear bits 4 to 7 to "0".	p. 380 <input type="checkbox"/>
TP0IOC2 to TP8IOC2 registers	Rewrite the TPnEES1, TPnEES0, TPnETS1, and TPnETS0 bits when the TPnCTL0.TPnCE bit = 0. (The same value can be written when the TPnCE bit = 1.) If rewriting was mistakenly performed, clear the TPnCE bit to 0 and then set the bits again.	p. 381 <input type="checkbox"/>			
	Be sure to clear bits 4 to 7 to "0".	p. 381 <input type="checkbox"/>			

Chapter	Classification	Function	Details of Function	Cautions	Page
Chapter 7	Soft	16-bit timer/event counter P (TMP)	TP7IOC3 to TP8IOC3 registers	Rewrite the TPmSCE, TPmZCL, TPmBCL, TPmACL, TPmECS1, TPmECS0, TPmEIS1, and TPmEIS0 bits when the TPmCTL0.TPmCE bit = 0. (The same value can be written to these bits when the TPmCE bit = 1.) If rewriting was mistakenly performed, clear the TPmCE bit to 0 and then set these bits again.	p. 383 <input type="checkbox"/>
			TP0OPT0 to TP8OPT0 registers	Rewrite the TPnCCS1 and TPnCCS0 bits when the TPnCE bit = 0. (The same value can be written when the TPnCE bit = 1.) If rewriting was mistakenly performed, clear the TPnCE bit to 0 and then set the bits again.	p. 384 <input type="checkbox"/>
				Be sure to clear bits 1 to 3, 6, and 7 to "0".	p. 384 <input type="checkbox"/>
			TP7OPT1 to TP8OPT1 registers	Be sure to clear bits 3 to 7 to "0".	p. 386 <input type="checkbox"/>
			TP0CCR0 to TP8CCR0 TP0CCR1 to TP8CCR1 TP0CNT to TP8CNT registers	Accessing the TPnCCR0, TPnCCR1 and TPnCNT register are prohibited in the following statuses. For details, refer to 3.4.9 (2) Accessing specific on-chip peripheral I/O registers. <ul style="list-style-type: none"> <li>When the CPU operates with the subclock and the main clock oscillation is stopped</li> <li>When the CPU operates with the internal oscillation clock</li> </ul>	pp. 387, 389, 391 <input type="checkbox"/>
			EN0NFC to EN1NFC registers	When using the TMPm encoder count function, enable TMPm after 2 or 3 sampling clocks have elapsed.	p. 392 <input type="checkbox"/>
			Operation (TMP0 to TMP6 registers)	To use the external event count mode, specify that the valid edge of the TIPk0 pin capture trigger input is not detected (by clearing the TPkIOC1.TPkIS1 and TPkIOC1.TPkIS0 bits to "00").	p. 395 <input type="checkbox"/>
				When using the external trigger pulse output mode, one-shot pulse output mode, and pulse width measurement mode, select the internal clock as the count clock (by clearing the TPkCTL1.TPkEEE bit to 0).	p. 395 <input type="checkbox"/>
			Operation (TMP7 to TMP8 registers)	To use the external event count mode, specify that the valid edge of the TIPm0 pin capture trigger input is not detected ((by clearing the TPmIOC1.TPmIS1 and TPmIOC1.TPmIS0 bits to "00").	p. 395 <input type="checkbox"/>
				When using the external trigger pulse output mode, one-shot pulse output mode, and pulse width measurement mode, select the internal clock as the count clock (by clearing the TPmCTL1.TPmEEE bit to 0).	p. 395 <input type="checkbox"/>
			Overflow operation (TMP0 to TMP6 registers)	After the overflow interrupt request signal (INTTPkOV) has been generated, be sure to check that the overflow flag (TPkOVF bit) is set to 1.	p. 396 <input type="checkbox"/>
			Overflow operation (TMP7 to TMP8 registers)	After the overflow interrupt request signal (INTTPmOV) has been generated, be sure to check that the overflow flag (TPmOVF, TPmEOF bits) is set to 1.	p. 397 <input type="checkbox"/>
Batch write	Writing to the TPnCCR1 register includes enabling of batch write. Thus, rewrite the TPnCCR1 register after rewriting the TPnCCR0 register.	p. 402 <input type="checkbox"/>			
Notes on rewriting TPnCCR0 register	When the value of the TPnCCR0 register is rewritten to a smaller value during counting, the 16-bit counter may overflow. If there is a possibility of overflow, stop counting and then change the set value.	pp. 411, 422, 442 <input type="checkbox"/>			



Chapter	Classification	Function	Details of Function	Cautions	Page
Chapter 7	Soft	16-bit timer/event counter P (TMP)	External event count mode	In the external event count mode, the TPnCCR0 and TPnCCR1 registers must not be cleared to 0000H.	p. 416 <input type="checkbox"/>
			Register setting for operation in external event count mode	Set the TPnIOC0 register to 00H.	p. 419 <input type="checkbox"/>
				When an external clock is used as the count clock, the external clock can be input only from the TIPn0 pin. At this time, set the TPnIOC1.TPnIS1 and TPnIOC1.TPnIS0 bits to 00 (capture trigger input (TIPn0 pin): no edge detection).	p. 419 <input type="checkbox"/>
			Operation timing in external event count mode	In the external event count mode, setting the TPnCCR0 and TPnCCR1 registers to 0000H is disabled.	p. 421 <input type="checkbox"/>
				In the external event count mode, use of the timer output (TOPn0, TOPn1) is disabled.	p. 421 <input type="checkbox"/>
			External trigger pulse output mode	In external trigger pulse output mode, select the internal clock (set TPnCTL1.TPnEEE bit = 0) as the count clock.	p. 425 <input type="checkbox"/>
			Notes on changing pulse width during operation	To change the PWM waveform while the counter is operating, write the TPnCCR1 register last. Rewrite the TPnCCRm register after writing the TPnCCR1 register after the INTTPnCC0 signal is detected.	p. 431 <input type="checkbox"/>
			One-shot pulse output mode	In one-shot pulse output mode, select the internal clock (set TPnCTL1.TPnEEE bit = 0) as the count clock.	p. 437 <input type="checkbox"/>
			Setting of registers in one-shot pulse output mode	One-shot pulses are not output even in the one-shot pulse output mode, if the value set in the TPnCCR1 register is greater than that set in the TPnCCR0 register.	p. 440 <input type="checkbox"/>
			Hard	Processing of overflow if capture trigger interval is long	If the pulse width is greater than one cycle of the 16-bit counter, care must be exercised because an overflow may occur more than once from the first capture trigger to the next.
	Soft	Note on capture operation		When the capture operation is used and a slow clock is selected as the count clock, FFFFH, not 0000H, may be captured in the TPnCCRa register, or the capture operation may not be performed (capture interrupt does not occur) if the capture trigger is input immediately after the TPnCTL0.TPnCE bit is set to 1. The same operation results during the period in which no external event counts are input while the capture operation is used and an external event count input is used as a count clock.	p. 470 <input type="checkbox"/>
		Pulse width measurement mode	When in pulse width measurement mode, select the internal clock (set TPnCTL1.TPnEEE bit = 0) as the count clock.	p. 471 <input type="checkbox"/>	
			If a slow clock is selected as the count clock, FFFFH, not 0000H, may be captured to the TPnCCRa register, or the capture operation may not be performed (capture interrupt does not occur) if the capture trigger is input immediately after the TPnCTL0.TPnCE bit has been set to 1.	p. 476 <input type="checkbox"/>	
		Encoder count function (only for TMP7 and TMP8)	When TPmUDS1 and TPmUDS0 bits = 10, specification of the valid edge of the TENCm0 and TENCm1 pins is invalid.	p. 481 <input type="checkbox"/>	
			When TPmUDS1 and TPmUDS0 bits = 11, specification of the valid edge of the TENCm0 and TENCm1 pins is invalid.	p. 482 <input type="checkbox"/>	
	The 16-bit counter is cleared to 0000H when the clear level condition of the TPmZCL, TPmBCL, and TPmACL bits match the input level of the TECRm, TENCm1, or TENCm0 pin.		p. 487 <input type="checkbox"/>		

Chapter	Chapter Classification	Function	Details of Function	Cautions	Page
Chapter 7	Soft	16-bit timer/event counter P (TMP)	Selector Function	When using the selector function, set the capture trigger input of TMP or TMQ before connecting the timer.	p. 499 <input type="checkbox"/>
				When setting the selector function, first disable the peripheral I/O to be connected (TMP/UARTA or TMQ/CAN controller).	p. 499 <input type="checkbox"/>
			SELCNT0 register	To set the ISEL0, ISEL1, ISEL3, ISEL4, and ISEL6 bits to 1, set the corresponding pin in the capture trigger input mode.	p. 500 <input type="checkbox"/>
			Switching of DMA transfer start factors	In the V850E/SJ3-H and V850E/SK3-H, the DMA transfer start factors INTTP0OV signal and INTUB0TIT signal, INTTP1OV signal and INTUB1TIR signal, and INTTP2OV signal and INTUB1TIT signal are used alternately and cannot be used simultaneously. To use the INTTP0OV, INTTP1OV, or INTTP2OV signal as DMA transfer start factors, set the DTFROB0 bit in the option byte area 0000007AH to 0 (see CHAPTER 33 OPTION BYTE FUNCTION). In this case, the INTUB0TIT, INTUB1TIR, and INTUB1TIT signals cannot be used as a DMA transfer start factor. For details, see Table 22-1 DMA Transfer Start Factors.	p. 501 <input type="checkbox"/>
Chapter 8	Soft	16-bit timer/event counter Q (TMQ)	TQ0CTL0 register	Set the TQ0CKS2 to TQ0CKS0 bits when the TQ0CE bit = 0.	p. 507 <input type="checkbox"/>
				When the value of the TQ0CE bit is changed from 0 to 1, the TQ0CKS2 to TQ0CKS0 bits can be set simultaneously.	
				Be sure to clear bits 3 to 6 to "0".	p. 507 <input type="checkbox"/>
			TQ0CTL1 register	Set the TQ0EEE and TQ0MD2 to TQ0MD0 bits when the TQ0CTL0.TQ0CE bit = 0. (The same value can be written when the TQ0CE bit = 1.) The operation is not guaranteed when rewriting is performed with the TQ0CE bit = 1. If rewriting was mistakenly performed, clear the TQ0CE bit to 0 and then set the bits again.	p. 508 <input type="checkbox"/>
				Be sure to clear bits 3, 4, and 7 to "0".	p. 508 <input type="checkbox"/>
			TQ0IOC0 register	The pin output changes if the setting of the TQ0IOC0 register is rewritten when the port is set to output TOQ0m. Therefore, note changes in the pin status by setting the port in the input mode and making the output status of the pins a highimpedance state.	p. 509 <input type="checkbox"/>
				Rewrite the TQ0OLm and TQ0OEm bits when the TQ0CTL0.TQ0CE bit = 0. (The same value can be written when the TQ0CE bit = 1.) If rewriting was mistakenly performed, clear the TQ0CE bit to 0 and then set the bits again.	p. 509 <input type="checkbox"/>
				Even if the TQ0OLm bit is manipulated when the TQ0CE and TQ0OEm bits are 0, the TOQ0m pin output level varies.	p. 509 <input type="checkbox"/>
			TQ0IOC1 register	Rewrite the TQ0IS7 to TQ0IS0 bits when the TQ0CTL0.TQ0CE bit = 0. (The same value can be written when the TQ0CE bit = 1.) If rewriting was mistakenly performed, clear the TQ0CE bit to 0 and then set the bits again.	p. 510 <input type="checkbox"/>
			TQ0IOC2 register	Rewrite the TQ0EES1, TQ0EES0, TQ0ETS1, and TQ0ETS0 bits when the TQ0CTL0.TQ0CE bit = 0. (The same value can be written when the TQ0CE bit = 1.) If rewriting was mistakenly performed, clear the TQ0CE bit to 0 and then set the bits again.	p. 511 <input type="checkbox"/>
TQ0OPT0 register	Rewrite the TQ0CCS3 to TQ0CCS0 bits when the TQ0CTL0.TQ0CE bit = 0. (The same value can be written when the TQ0CE bit = 1.) If rewriting was mistakenly performed, clear the TQ0CE bit to 0 and then set the bits again.	p. 512 <input type="checkbox"/>			
	Be sure to clear bits 1 to 3 to "0".	p. 512 <input type="checkbox"/>			

Chapter	Classification	Function	Details of Function	Cautions	Page	
Chapter 8	Soft	16-bit timer/event counter Q (TMQ)	TQ0CCR0 to TQ0CCR3, TQ0CNT registers	Accessing the TQ0CCR0 to TQ0CCR3, and TQ0CNT registers is prohibited in the following statuses. For details, refer to 3.4.9 (2) Accessing specific on-chip peripheral I/O registers. <ul style="list-style-type: none"> <li>• When the CPU operates with the subclock and the main clock oscillation is stopped</li> <li>• When the CPU operates with the internal oscillation clock</li> </ul>	pp. 513, 515, 517, 519, 521	<input type="checkbox"/>
			Operation	To use the external event count mode, specify that the valid edge of the TIQ00 pin capture trigger input is not detected (by clearing the TQ0IOC1.TQ0IS1 and TQ0IOC1.TQ0IS0 bits to "00").	p. 522	<input type="checkbox"/>
				When using the external trigger pulse output mode, one-shot pulse output mode, and pulse width measurement mode, select the internal clock as the count clock (by clearing the TQ0CTL1.TQ0EEE bit to 0).	p. 522	<input type="checkbox"/>
			Overflow operation	After the overflow interrupt request signal (INTTQ0OV) has been generated, be sure to check that the overflow flag (TQ0OVF bit) is set to 1.	p. 523	<input type="checkbox"/>
			Batch write	Writing to the TQ0CCR1 register includes enabling of batch write. Thus, rewrite the TQ0CCR1 register after rewriting the TQ0CCR0, TQ0CCR2, and TQ0CCR3 registers.	p. 528	<input type="checkbox"/>
			Notes on rewriting TQ0CCR0 register	If the value of the TQ0CCR0 register is rewritten to a smaller value during counting, the 16-bit counter may overflow. If there is a possibility of overflow, stop counting and then change the set value.	pp. 536, 547, 571	<input type="checkbox"/>
			External event count mode	In the external event count mode, the TQ0CCR0 to TQ0CCR3 registers must not be cleared to 0000H.	p. 541	<input type="checkbox"/>
				Set the TQ0IOC0 register to 00H.	p. 544	<input type="checkbox"/>
				When an external clock is used as the count clock, the external clock can be input only from the TIQ00 pin. At this time, set the TQ0IOC1.TQ0IS1 and TQ0IOC1.TQ0IS0 bits to 00 (capture trigger input (TIQ00 pin): no edge detection).	p. 544	<input type="checkbox"/>
			Operation timing in external event count mode	In the external event count mode, setting the TQ0CCR0 to TQ0CCR3 registers to 0000H is disabled.	p. 546	<input type="checkbox"/>
				In the external event count mode, use of the timer output (TOQ00 to TOQ03) is disabled.	p. 546	<input type="checkbox"/>
			External trigger pulse output mode	In external trigger pulse output mode, select the internal clock (set the TQ0CTL1.TQ0EEE bit = 0) as the count clock	p. 551	<input type="checkbox"/>
			Note on changing pulse width during operation	To change the PWM waveform while the counter is operating, write the TQ0CCR1 register last. Rewrite the TQ0CCRk register after writing the TQ0CCR1 register after the INTTQ0CC0 signal is detected.	p. 558	<input type="checkbox"/>
			One-shot pulse output mode	In one-shot pulse output mode, select the internal clock (set the TQ0CTL1.TQ0EEE bit = 0) as the count clock.	p. 564	<input type="checkbox"/>
	One-shot pulses are not output even in the one-shot pulse output mode, if the value set in the TQ0CCR0 register is greater than that set in the TQ0CCRk register.	p. 568		<input type="checkbox"/>		
Hard	Processing of overflow if capture trigger interval is long	If the pulse width is greater than one cycle of the 16-bit counter, care must be exercised because an overflow may occur more than once from the first capture trigger to the next.	p. 602	<input type="checkbox"/>		

Chapter	Classification	Function	Details of Function	Cautions	Page
Chapter 8	Soft	16-bit timer/event counter Q (TMQ)	Capture operation	If the capture operation is used and if a slow clock is selected as the count clock, FFFFH, not 0000H, may be captured to the TQ0CCRm register, or the capture operation may not be performed (capture interrupt does not occur) if the capture trigger is input immediately after the TQ0CTL0.TQ0CE bit is set to 1 (m = 0 to 3) The same operation results during the period in which no external event counts are input while the capture operation is used and an external event count input is used as a count clock.	p. 604 <input type="checkbox"/>
			Pulse width measurement mode	In the pulse width measurement mode, select the internal clock (set the TQ0CTL1.TQ0EEE bit = 0) as the count clock.	p. 605 <input type="checkbox"/>
				If a slow clock is selected as the count clock, FFFFH, not 0000H, may be captured to the TQ0CCRm register, or the capture operation may not be performed (capture interrupt does not occur) if the capture trigger is input immediately after the TQ0CTL0.TQ0CE bit is set to 1 (m = 0 to 3).	p. 610 <input type="checkbox"/>
			Switching of DMA transfer start factor	In the V850E/SJ3-H and V850E/SK3-H, the INTTQ0OV and INTUB0TIR signals, which are the DMA transfer start factors, share the same pin, and they cannot be used at the same time. To use the INTTQ0OV signal as the DMA transfer start factor, set the DTFROB0 bit of the option byte 0000007AH to 0 (refer to CHAPTER 33 OPTION BYTE FUNCTION). In this case, the INTUB0TIR signal cannot be used as the DMA transfer start factor. For details, see Table 22-1 DMA Transfer Start Factors.	p. 611 <input type="checkbox"/>
	Hard	Using TIQ0m pin and KRn pin at the same time	The TIQ0m pin and the KRn pin cannot be used at the same time (m = 0 to 3, n = 0 to 3). Although the TIQ00/KR3 pin and the TIQ03/KR2 pin are assigned to two different ports each, the pins cannot be used at the same time at different ports.	p. 611 <input type="checkbox"/>	
Chapter 9	Soft	16-bit interval timer M (TMM)	TM0CTL0 to TM2CTL0 register	Set the TMnCKS2 to TMnCKS0 bits when TMnCE bit = 0. When changing the value of TMnCE from 0 to 1, it is not possible to set the value of the TMnCKS2 to TMnCKS0 bits simultaneously. Be sure to clear bits 3 to 6 to "0".	p. 615 <input type="checkbox"/>
				p. 615 <input type="checkbox"/>	
			Interval timer mode operation timing	Do not set the TMnCMP0 register to FFFFH.	pp. 616, 619, 620 <input type="checkbox"/>
			Count operation	It might take some time to start counting after the TMnCTL0.TMnCE bit is set to 1. Refer to 9.4.2 (1) Maximum time before counting start.	p. 620 <input type="checkbox"/>
			TM0CMP0, TM0CTL0 registers	Rewriting the TMnCMP0 and TMnCTL0 registers is prohibited while TMMn is operating. If these registers are rewritten while the TMnCE bit is 1, the operation cannot be guaranteed. If they are rewritten by mistake, clear the TMnCTL0.TMnCE bit to 0, and re-set the registers	p. 620 <input type="checkbox"/>
			Switching DMA transfer start factor	In the V850E/SJ3-H and V850E/SK3-H, the INTTM1EQ0 and INTKR signals and the INTTM2EQ0 and INTP8 signals, which are the DMA transfer start factors, respectively share the same pin, and they cannot be used at the same time. To use INTTM1EQ0 or INTTM2EQ0 signal as the DAM transfer start factor, set the DTFROB0 bit of the option byte 0000007AH to 1. (Refer to CHAPTER 33 OPTION BYTE FUNCTION.) In this case, the INTKR and INTP8 signals cannot be used as the DMA transfer start factor. Remark For details, see Table 22-1 DMA Transfer Start Factors.	p. 620 <input type="checkbox"/>

Chapter	Classification	Function	Details of Function	Cautions	Page
Chapter 10	Soft	Watch timer function	PRSM0 register	Do not change the values of the BGCS00 and BGCS01 bits during watch timer operation.	p. 624 <input type="checkbox"/>
				Set the PRSM0 register before setting the BGCE0 bit to 1.	p. 624 <input type="checkbox"/>
				To realize the watch function by the watch timer or the real-time counter (RTC), set the PRSM0 and PRSCM0 registers according to the main oscillation clock frequency (fx) to be used so as to obtain an f <sub>BRG</sub> frequency of 32.768 kHz.	p. 624 <input type="checkbox"/>
				Be sure to set bits 2, 3, and 5 to 7 to "0".	p. 624 <input type="checkbox"/>
			PRSCM0 register	Do not rewrite the PRSCM0 register during watch timer operation.	p. 625 <input type="checkbox"/>
				Set the PRSCM0 register before setting the PRSM0.BGCE0 bit to 1.	p. 625 <input type="checkbox"/>
				To realize the watch function by the watch timer or the real-time counter (RTC), set the PRSM0 and PRSCM0 registers according to the main oscillation clock frequency (fx) to be used so as to obtain an f <sub>BRG</sub> frequency of 32.768 kHz.	p. 625 <input type="checkbox"/>
			WTM register	Rewrite the WTM2 to WTM7 bits while both the WTM0 and WTM1 bits are 0.	p. 629 <input type="checkbox"/>
			INTWT signal	Some time is required before the first watch timer interrupt request signal (INTWT) is generated after operation is enabled (WTM.WTM1 and WTM.WTM0 bits = 1).	p. 631 <input type="checkbox"/>
			Hard	Soft	RC1CC0 register
	The RC1CKS bit can be rewritten only when the operation of the realtime counter is stopped (RC1PWR bit = 0). Rewriting the RC1CKS bit as soon as setting the RC1PWR bit from "0" to "1" is prohibited.	p. 636 <input type="checkbox"/>			
	Be sure to set bits 0 to 5 to "0".	p. 636 <input type="checkbox"/>			
	RC1CC1 register	Writing "0" to the RTCE bit is prohibited while the RTCE bit = 1. Clear (0) the RTCE bit by clearing (0) the RC1PWR bit as described in 10.5.4 (8) Initializing real-time counter.			p. 637 <input type="checkbox"/>
		The RC1CK1HZ output pin operates as follows when the setting of the CLOE1 bit is changed. • If CLOE1 bit is changed from 0 to 1: RC1CK1HZ outputs a pulse of 1 Hz after up to 2 clocks. • If CLOE1 bit is changed from 1 to 0: RC1CK1HZ output is stopped after up to 2 clocks (fixed to low level).			p. 637 <input type="checkbox"/>
		For how to set or change the AMPM bit, refer to 10.5.4 (1) Initialization and 10.5.4 (2) Rewriting each counter during clock operation. When the AMPM bit has been rewritten, re-set the RC1HOUR register.			p. 637 <input type="checkbox"/>
		To rewrite the CT2 to CT0 bits while the real-time counter is operating (RC1PWR bit = 1), refer to 10.5.4 (4) Changing setting of INTRTC0 interrupt during clock operation. Be sure to set bit 6 to "0".			p. 637 <input type="checkbox"/>
	RC1CC2 register	To rewrite the WALE bit while the real-time counter is operating (RC1CC0.RC1PWR bit = 1), refer to 10.5.4 (5) Changing setting of INTRTC1 interrupt during clock operation.			p. 638 <input type="checkbox"/>
		To read or write the value of each counter, confirm that the RWST bit is 1.			p. 638 <input type="checkbox"/>
		Even if the RWAIT bit is set to "0", the RWST bit is not set to 0 while each counter is being rewritten. It is set to 0 after writing of each counter has been completed.			p. 638 <input type="checkbox"/>
		Be sure to set bits 2 to 6 to "0".	p. 638 <input type="checkbox"/>		
RC1CC3 register	To rewrite the RINTE bit while the real-time counter is operating (RCC1CC0.RC1PWR bit = 1), refer to 10.5.4 (7) Changing setting of INTRTC2 interrupt during clock operation.	p. 639 <input type="checkbox"/>			

Chapter	Classification	Function	Details of Function	Cautions	Page	
Chapter 10	Soft	Watch timer function	RC1CC3 register	The RC1CKDIV output pin operates as follows when the setting of the CLOE2 bit is changed.	p. 639	<input type="checkbox"/>
				<ul style="list-style-type: none"> <li>• When CLOE2 bit is changed from 0 to 1: The pulse set by the CKDIV bit is output after up to 2 clocks.</li> <li>• When CLOE2 bit is changed from 1 to 0: Output by the RC1CKDIV pin is stopped after up to 2 clocks (fixed to low level).</li> </ul>		
				To rewrite the ICT2 to ICT0 bits while the real-time counter is operating (RC1PWR bit = 1), refer to 10.5.4 (7) Changing setting of INTRTC2 interrupt during clock operation.	p. 639	<input type="checkbox"/>
				Be sure to set bits 3 and 4 to "0".	p. 639	<input type="checkbox"/>
			RC1SUBU register	The value of this register may reach or exceed 8000H if the time is corrected by using the RC1SUBU register.	p. 640	<input type="checkbox"/>
				The RC1SUBC register is also cleared by writing the second count register.	p. 640	<input type="checkbox"/>
				The value of the RC1SUBC register is not guaranteed if it is read during operation because a value that is changing is read.	p. 640	<input type="checkbox"/>
			RC1SEC register	Setting values other than 00 to 59 to the RC1SEC register is prohibited.	p. 640	<input type="checkbox"/>
			RC1MIN register	Setting a value other than 00 to 59 to the RC1MIN register is prohibited.	p. 641	<input type="checkbox"/>
			RC1HOUR register	Setting a value other than 01 to 12, 21 to 32 (AMPM bit = 0) or 00 to 23 (AMPM bit = 1) to the RC1HOUR register is prohibited.	p. 641	<input type="checkbox"/>
			RC1DAY register	Setting a value other than 01 to 31 to the RC1DAY register is prohibited. In addition, setting outside the above count range, such as "February 30", is prohibited.	p. 643	<input type="checkbox"/>
			RC1WEEK register	Setting a value other than 00 to 06 to the RC1WEEK register is prohibited.	p. 644	<input type="checkbox"/>
				A value corresponding to the month count register and day count register is not always stored automatically in the week count register.	p. 644	<input type="checkbox"/>
			RC1MONTH register	Setting a value other than 01 to 12 to the RC1MONTH register is prohibited.	p. 645	<input type="checkbox"/>
			RC1YEAR register	Setting a value other than 00 to 99 to the RC1YEAR register is prohibited.	p. 645	<input type="checkbox"/>
			RC1ALM register	Set a BCD code of 00 to 59 (decimal number) to this register. If a value other than this range is set, the alarm is not detected.	p. 647	<input type="checkbox"/>
				To rewrite the RC1ALM register while the real-time counter is operating (RC1CC0.RC1PWR bit = 1), refer to 10.5.4 (5) Changing setting of INTRTC1 interrupt during clock operation.	p. 647	<input type="checkbox"/>
			RC1ALH register	Set a BCD code of 00 to 23, 01 to 12, or 21 to 32 (decimal number) to this register. If a value other than this range is set, the alarm is not detected.	p. 647	<input type="checkbox"/>
				To rewrite the RC1ALH register while the real-time counter is operating (RC1CC0.RC1PWR bit = 1), refer to 10.5.4 (5) Changing setting of INTRTC1 interrupt during clock operation.	p. 647	<input type="checkbox"/>
			RCTALW register	To rewrite the RC1ALW register while the real-time counter is operating (RC1CC0.RC1PWR bit = 1), refer to 10.5.4 (5) Changing setting of INTRTC1 interrupt during clock operation.	p. 648	<input type="checkbox"/>
Operation	Be sure to confirm that the RWST bit = 0 before entering the STOP mode.	pp. 650, 651	<input type="checkbox"/>			
	Clear the RWAIT bit to 0 within 1 second. If the RWAIT bit = 1, the RC1SEC to RC1YEAR registers stop operation. If the first carry occurs from the RC1SUBC register while the RWAIT bit = 1, it is internally retained. If the second carry or those that follow occur, however, the number of times the carry has occurred cannot be retained.	pp. 650, 651	<input type="checkbox"/>			

Chapter	Classification	Function	Details of Function	Cautions	Page
Chapter 10	Soft	Watch timer function	Operation	Set RC1CC3.ICT2 to ICT0 bits and RC1CC3.RINTE bit at the same time or set ICT2 to ICT0 bits first in initialization setting of INTRTC2 interrupt. If RINTE bit is set first, an unintended waveform of the interrupt may be output.	p. 654 <input type="checkbox"/>
Chapter 11	Soft	Functions of watchdog timer 2	Default start watchdog timer	When watchdog timer 2 is not used or when changing the operation mode, be sure to always set the WDTMD1 bit of the option byte 0000007AH to 0. Changing modes with the WDTM2 register when the WDTMD1 bit is set to 1 is invalid.	p. 661 <input type="checkbox"/>
				Watchdog timer 2 automatically starts in the reset mode following reset release. When watchdog timer 2 is not used, either stop its operation before reset is executed via this function, or clear watchdog timer 2 once and stop it within the next interval time.	p. 661 <input type="checkbox"/>
				Also, write to the WDTM2 register for verification purposes only once, even if the default settings (reset mode, interval time: $f_R/2^{19}$ ) do not need to be changed.	
				For the non-maskable interrupt servicing due to a non-maskable interrupt request signal (INTWDT2), see 24.2.2 (2) INTWDT2 signal.	p. 661 <input type="checkbox"/>
			WDTM2 register	Accessing the WDTM2 register is prohibited in the following statuses. For details, refer to 3.4.9 (2) Accessing specific on-chip peripheral I/O registers.	p. 663 <input type="checkbox"/>
				<ul style="list-style-type: none"> <li>When the CPU operates with the subclock and the main clock oscillation is stopped</li> <li>When the CPU operates with the internal oscillation clock</li> </ul>	
				When watchdog timer 2 is not used or when changing the operation mode, be sure to always set the WDTMD1 bit of the option byte 0000007AH to 0. Changing modes with the WDTM2 register when the WDTMD1 bit is set to 1 is invalid.	p. 664 <input type="checkbox"/>
				Although watchdog timer 2 can be stopped just by stopping the operation of the internal oscillator, clear the WDTM2 register to 00H to securely stop the timer (to avoid selection of the main clock or subclock due to an erroneous write operation).	p. 664 <input type="checkbox"/>
				If the WDTM2 register is rewritten twice after reset, an overflow signal is forcibly generated and the counter is reset.	p. 664 <input type="checkbox"/>
				To intentionally generate an overflow signal, write to the WDTM2 register only twice or write a value other than "ACH" to the WDTE register once.	p. 664 <input type="checkbox"/>
				However, when watchdog timer 2 is set to stop operation, an overflow signal is not generated even if data is written to the WDTM2 register only twice, or a value other than "ACH" is written to the WDTE register only once.	
				To stop the operation of watchdog timer 2, set the RCM.RSTOP bit to 1 (to stop the internal oscillator) and write 00H in the WDTM2 register. If the RCM.RSTOP bit cannot be set to 1, set the WDCS23 bit to 1 ( $2^7/f_{XP}$ is selected and the clock can be stopped in the IDLE1, IDLW2, sub-IDLE, and subclock operation modes).	p. 664 <input type="checkbox"/>
				However, when the WDTMD1 bit of the option byte 0000007AH (see CHAPTER 33 OPTION BYTE FUNCTION) is set to 1, the clock cannot be stopped other than be reset.	
Be sure to clear bit 7 to "0".	p. 664 <input type="checkbox"/>				
When the WDTMD1 bit of the option byte 0000007AH (see CHAPTER 33 OPTION BYTE FUNCTION) is set to 1, the clock is fixed to the internal oscillation clock ( $f_R$ ) ( $2^{12}/f_R$ to $2^{19}/f_R$ selectable).	p. 665 <input type="checkbox"/>				
WDTE register	When a value other than "ACH" is written to the WDTE register, an overflow signal is forcibly output.	p. 666 <input type="checkbox"/>			
	When a 1-bit memory manipulation instruction is executed for the WDTE register, an overflow signal is forcibly output.	p. 666 <input type="checkbox"/>			

Chapter	Classification	Function	Details of Function	Cautions	Page
Chapter 11	Soft	Functions of watchdog timer 2	WDTE register	To intentionally generate an overflow signal, write to the WDTM2 register only twice or write a value other than "ACH" to the WDTE register once. However, when the watchdog timer 2 is set to stop operation, an overflow signal is not generated even if data is written to the WDTM2 register only twice, or a value other than "ACH" is written to the WDTE register only once.	p. 666 <input type="checkbox"/>
				The read value of the WDTE register is "9AH" (which differs from written value "ACH").	p. 666 <input type="checkbox"/>
Chapter 12	Soft	Real-time output function (RTO)	RTBLn, RTBHn registers	When writing to bits 6 and 7 of the RTBHn register, always write 0.	p. 670 <input type="checkbox"/>
				Accessing the RTBLn and RTBHn registers is prohibited in the following statuses. For details, refer to 3.4.9 (2) Accessing specific on-chip peripheral I/O registers. <ul style="list-style-type: none"> <li>When the CPU operates with the subclock and the main clock oscillation is stopped</li> <li>When the CPU operates with the internal oscillation clock</li> </ul>	p. 670 <input type="checkbox"/>
			RTPMn register	If real-time output is disabled (RTPOEn bit = 0), the real-time output pins (RTPn0 to RTPn5) all output 0, regardless of the RTPMn register setting.	p. 671 <input type="checkbox"/>
				Be sure to set bits 6 and 7 to "0".	p. 671 <input type="checkbox"/>
			RTPCn register	Set the RTPEGn, BYTEn, and EXTRn bits only when RTPOEn bit = 0.	p. 672 <input type="checkbox"/>
			Preventing conflicts	Prevent the following conflicts by software. <ul style="list-style-type: none"> <li>Conflict between real-time output disable/enable switching (RTPOEn bit) and selected real-time output trigger.</li> <li>Conflict between writing to the RTBHn and RTBLn registers in the real-time output enabled status and the selected real-time output trigger.</li> </ul>	p. 674 <input type="checkbox"/>
			Initialization	Before performing initialization, disable real-time output (RTPOEn bit = 0).	p. 674 <input type="checkbox"/>
			If real-time output has been disabled	Once real-time output has been disabled (RTPOEn bit = 0), be sure to initialize the RTBHn and RTBLn registers before enabling real-time output again (RTPOEn bit = 0 → 1).	p. 674 <input type="checkbox"/>
Chapter 13	Hard	A/D converter	ANI0 to ANI15 pin	Make sure that the voltages input to the ANI0 to ANI15 pins do not exceed the rated values. In particular if a voltage of AVREF0 or higher is input to a channel, the conversion value of that channel becomes undefined, and the conversion values of the other channels may also be affected.	p. 678 <input type="checkbox"/>
			Soft	ADA0M0, ADA0CRn, ADA0CRnH register	Accessing the ADA0M0, ADA0CRn, or ADA0CRnH register is prohibited in the following statuses. For details, refer to 3.4.9 (2) Accessing specific on-chip peripheral I/O registers. <ul style="list-style-type: none"> <li>When the CPU operates with the subclock and the main clock oscillation is stopped</li> <li>When the CPU operates with the internal oscillation clock</li> </ul>
	ADA0M0 register	Changing the ADA0M1 register is prohibited while A/D conversion is enabled (ADA0CE bit = 1).		p. 680 <input type="checkbox"/>	
		In the following modes, write data to the ADA0M0, ADA0M2, ADA0S, ADA0PFM, and ADA0PFT registers while A/D conversion is stopped (ADA0CE bit = 0), and then enable the A/D conversion operation (ADA0CE bit = 1). <ul style="list-style-type: none"> <li>Normal conversion mode</li> <li>One-shot select mode/one-shot scan mode of high-speed conversion mode</li> </ul>		p. 680 <input type="checkbox"/>	
	ADA0M1 register	To select the external trigger mode/timer trigger mode (ADA0TMD bit = 1), set the high-speed conversion mode (ADA0M1.ADA0HS1 bit = 1). Do not input a trigger during stabilization time that is inserted once after the A/D conversion operation is enabled (ADA0CE bit = 1).	p. 680 <input type="checkbox"/>		
ADA0M1 register	Changing the ADA0M1 register is prohibited while A/D conversion is enabled (ADA0M0.ADA0CE bit = 1).	p. 681 <input type="checkbox"/>			



Chapter	Classification	Function	Details of Function	Cautions	Page	
Chapter 13	Soft	A/D converter	ADA0M1 register	To select the external trigger mode/timer trigger mode (ADA0M0.ADA0TMD bit = 1), set the high-speed conversion mode (ADA0M1.ADA0HS1 bit = 1). Do not input a trigger during stabilization time that is inserted only once after the A/D conversion operation is enabled (ADA0CE bit = 1).	p. 681 <input type="checkbox"/>	
				Be sure to clear bits 6 to 4 to "0".	p. 681 <input type="checkbox"/>	
				Set as $2.6 \mu\text{s} \leq \text{conversion time} \leq 10.4 \mu\text{s}$ .	pp. 682, 683 <input type="checkbox"/>	
			ADA0M2 register	In the following modes, write data to the ADA0M2 register while A/D conversion is stopped (ADA0M0.ADA0CE bit = 0), and then enable the A/D conversion operation (ADA0CE bit = 1).	<ul style="list-style-type: none"> <li>• Normal conversion mode</li> <li>• One-shot select mode/one-shot scan mode of the high-speed conversion mode</li> </ul>	p. 684 <input type="checkbox"/>
				Be sure to clear bits 7 to 2 to "0".	p. 684 <input type="checkbox"/>	
			ADA0S register	In the following modes, write data to the ADA0S register while A/D conversion is stopped (ADA0M0.ADA0CE bit = 0), and then enable the A/D conversion operation (ADA0CE bit = 1).	<ul style="list-style-type: none"> <li>• Normal conversion mode</li> <li>• One-shot select mode/one-shot scan mode of the high-speed conversion mode</li> </ul>	p. 685 <input type="checkbox"/>
				Be sure to clear bits 7 to 4 to "0".	p. 685 <input type="checkbox"/>	
			ADA0CRn, ADA0CRnH registers	A write operation to the ADA0M0 and ADA0S registers may cause the contents of the ADA0CRn register to become undefined. After the conversion, read the conversion result before writing to the ADA0M0 and ADA0S registers. Correct conversion results may not be read if a sequence other than the above is used.	p. 686 <input type="checkbox"/>	
			ADA0PFM register	In the following modes, write data to the ADA0PFM register while A/D conversion is stopped (ADA0M0.ADA0CE bit = 0), and then enable the A/D conversion operation (ADA0CE bit = 1).	<ul style="list-style-type: none"> <li>• Normal conversion mode</li> <li>• One-shot select mode/one-shot scan mode of the high-speed conversion mode</li> </ul>	p. 688 <input type="checkbox"/>
				Be sure to set bits 0 to 5 to "0".	p. 688 <input type="checkbox"/>	
			ADA0PFT register	In the following modes, write data to the ADA0PFT register while A/D conversion is stopped (ADA0M0.ADA0CE bit = 0), and then enable the A/D conversion operation (ADA0CE bit = 1).	<ul style="list-style-type: none"> <li>• Normal conversion mode</li> <li>• One-shot select mode/one-shot scan mode of the high-speed conversion mode</li> </ul>	p. 689 <input type="checkbox"/>
			External trigger mode	To select the external trigger mode, set the high-speed conversion mode. Do not input a trigger during stabilization time that is inserted once after the A/D conversion operation is enabled (ADA0M0.ADA0CE bit = 1).	p. 692 <input type="checkbox"/>	
Timer trigger mode	To select the timer trigger mode, set the high-speed conversion mode. Do not input a trigger during stabilization time that is inserted once after the A/D conversion operation is enabled (ADA0M0.ADA0CE bit = 1).	p. 693 <input type="checkbox"/>				
Input range of ANI0 to ANI15 pins	Input the voltage within the specified range to the ANI0 to ANI15 pins. If a voltage equal to or higher than $AV_{\text{REF0}}$ or equal to or lower than $AV_{\text{SS}}$ (even within the range of the absolute maximum ratings) is input to any of these pins, the conversion value of that channel is undefined, and the conversion value of the other channels may also be affected.	p. 703 <input type="checkbox"/>				

Chapter	Classification	Function	Details of Function	Cautions	Page
Chapter 13	Hard	A/D converter	Countermeasures against noise	To maintain the 10-bit resolution, the ANI0 to ANI15 pins must be effectively protected from noise. The influence of noise increases as the output impedance of the analog input source becomes higher. To lower the noise, connecting an external capacitor is recommended.	p. 703 <input type="checkbox"/>
			Alternate I/O	The analog input (ANI0 to ANI15) pins are multiplexed with port pins. The AVREF0 power pin is multiplexed with the reference power supply to the A/D converter and the I/O buffer power supply of port 7. If any of the processings described in 13.6 (4) (a) to (c) is performed during A/D conversion, therefore, the expected A/D conversion value may not be obtained.	p. 704 <input type="checkbox"/>
		Soft	Interrupt request flag (ADIF)	The interrupt request flag (ADIF) is not cleared even if the contents of the ADA0S register are changed. If the analog input pin is changed during A/D conversion, therefore, the result of converting the previously selected analog input signal may be stored and the conversion end interrupt request flag may be set immediately before the ADA0S register is rewritten. If the ADIF flag is read immediately after the ADA0S register is rewritten, the ADIF flag may be set even though the A/D conversion of the newly selected analog input pin has not been completed. When A/D conversion is stopped, clear the ADIF flag before resuming conversion.	p. 705 <input type="checkbox"/>
	Hard	AVREF0 pin		The AVREF0 pin is used as the power supply pin of the A/D converter and also supplies power to the alternate-function ports. In an application where a backup power supply is used, be sure to supply the same voltage as VDD to the AVREF0 pin.	p. 706 <input type="checkbox"/>
				The AVREF0 pin is also used as the reference voltage pin of the A/D converter. If the source supplying power to the AVREF0 pin has a high impedance or if the power supply has a low current supply capability, the reference voltage may fluctuate due to the current that flows during conversion (especially, immediately after the conversion operation enable bit ADA0CE has been set to 1). As a result, the conversion accuracy may drop. To avoid this, it is recommended to connect a capacitor across the AVREF0 and AVSS pins to suppress the reference voltage fluctuation as shown in Figure 13-15.	p. 706 <input type="checkbox"/>
				If the source supplying power to the AVREF0 pin has a high DC resistance (for example, because of insertion of a diode), the voltage when conversion is enabled may be lower than the voltage when conversion is stopped, because of a voltage drop caused by the A/D conversion current.	p. 706 <input type="checkbox"/>
	Soft	Reading ADA0CRn register	When the ADA0M0 to ADA0M2, ADA0S, ADA0PFM, or ADA0PFT register is written, the contents of the ADA0CRn register may be undefined. Read the conversion result after completion of conversion and before writing to the ADA0M0 to ADA0M2, ADA0S, ADA0PFM, or ADA0PFT register. Also, when an external/timer trigger is acknowledged, the contents of the ADA0CRn register may be undefined. Read the conversion result after completion of conversion and before the next external/timer trigger is acknowledged. The correct conversion result may not be read at a timing different from the above.	p. 706 <input type="checkbox"/>	

Chapter	Classification	Function	Details of Function	Caution	Page
Chapter 13	Soft	A/D converter	Standby mode	Because the A/D converter stops operating in the STOP mode, conversion results are invalid, so power consumption can be reduced. Operations are resumed after the STOP mode is released, but the A/D conversion results after the STOP mode is released are invalid. When using the A/D converter after the STOP mode is released, before setting the STOP mode or releasing the STOP mode, clear the ADA0M0.ADA0CE bit to 0 then set the ADA0CE bit to 1 after releasing the STOP mode. In the IDLE1, IDLE2, or subclock operation mode, operation continues. To lower the power consumption, therefore, clear the ADA0M0.ADA0CE bit to 0. In the IDLE1 and IDLE2 modes, since the analog input voltage value cannot be retained, the A/D conversion results after the IDLE1 and IDLE2 modes are released are invalid. The results of conversions before the IDLE1 and IDLE2 modes were set are valid.	p. 706 <input type="checkbox"/>
			Restriction for each mode	To select the external trigger mode/timer trigger mode, set the high-speed conversion mode. Do not input a trigger during stabilization time that is inserted once after the A/D conversion operation is enabled (ADA0M0.ADA0CE bit = 1).	p. 707 <input type="checkbox"/>
			Variation of A/D conversion results	The results of the A/D conversion may vary depending on the fluctuation of the supply voltage, or may be affected by noise. To reduce the variation, take counteractive measures with the program such as averaging the A/D conversion results.	p. 707 <input type="checkbox"/>
	Hard	A/D conversion result hysteresis characteristics	The successive comparison type A/D converter holds the analog input voltage in the internal sample & hold capacitor and then performs A/D conversion. After the A/D conversion has finished, the analog input voltage remains in the internal sample & hold capacitor. As a result, the following phenomena may occur. <ul style="list-style-type: none"> <li>• When the same channel is used for A/D conversions, if the voltage is higher or lower than the previous A/D conversion, then hysteresis characteristics may appear where the conversion result is affected by the previous value. Thus, even if the conversion is performed at the same potential, the result may vary.</li> <li>• When switching the analog input channel, hysteresis characteristics may appear where the conversion result is affected by the previous channel value. This is because one A/D converter is used for the A/D conversions. Thus, even if the conversion is performed at the same potential, the result may vary.</li> </ul>	p. 707 <input type="checkbox"/>	
Chapter 14	Soft	D/A converter	DA0M register	Be sure to set bits 2, 3, 6, and 7 to "0".	p. 713 <input type="checkbox"/>
			DA0CS0, DA0CS1 registers	In the real-time output mode (DA0M.DA0MDn bit = 1), set the DA0CSn register before the INTTP2CC0/INTTP3CC0 signals are generated. D/A conversion starts when the INTTP2CC0/INTTP3CC0 signals are generated.	p. 714 <input type="checkbox"/>
			Cautions	Do not change the set value of the DA0CSn register while the trigger signal is being issued in the real-time output mode.	p. 716 <input type="checkbox"/>
				Before changing the operation mode, be sure to clear the DA0M.DA0CEn bit to 0.	p. 716 <input type="checkbox"/>
	Hard	D/A converter	Cautions	When using one of the P10/AN00 and P11/AN01 pins as an I/O port and the other as a D/A output pin, do so in an application where the port I/O level does not change during D/A output.	p. 716 <input type="checkbox"/>
				Make sure that $AV_{REF0} = V_{DD} = AV_{REF1} = 3.0$ to $3.6$ V.	p. 716 <input type="checkbox"/>
				Apply and cut power to $AV_{REF1}$ at the same timing as $AV_{REF0}$ .	p. 716 <input type="checkbox"/>
				No current can be output from the ANOn pin (n = 0, 1) because the output impedance of the D/A converter is high. When connecting a resistor of 2 MΩ or less, insert a JFET input operational amplifier between the resistor and the ANOn pin.	p. 716 <input type="checkbox"/>
Soft	D/A converter	Cautions	Because the D/A converter stops operation in the STOP mode, the ANO0 and ANO1 pins go into a high-impedance state, and the power consumption can be reduced. In the IDLE1, IDLE2, or subclock operation mode, however, the operation continues. To lower the power consumption, therefore, clear the DA0M.DA0CEn bit to 0.	p. 716 <input type="checkbox"/>	

Chapter	Classification	Function	Details of Function	Cautions	Page	
Chapter 15	Soft	Asynchronous serial interface A (UARTA)	Port settings during operation	Do not switch port settings during operation. Also, be sure to disable operation of unused units for which port settings are not made.	pp. 718, 720	<input type="checkbox"/>
			UA0OPT0 to UA0OPT5 registers	Do not set the UAnSRT and UAnSTT bits (to 1) during SBF reception (UAnSRF bit = 1).	p. 727	<input type="checkbox"/>
			UA0STR to UA5STR register	Be sure to read the error flags of the UAnPE, UAnFE, and UAnOVE bits to check the flag status, and then clear the flags by writing "0" to them. Be sure to set bits 3 to 6 to "0".	p. 729 p. 730	<input type="checkbox"/>
			SBF reception	The LIN function does not assume that SBF is transmitted while data is being received. Consequently, if SBF is transmitted while data is being received, a framing error occurs (UAnSTR.UAnFE bit = 1).	p. 738	<input type="checkbox"/>
			Continuous transmission procedure	When initializing transmissions during the execution of continuous transmissions, make sure that the UAnSTR.UAnTSF bit is 0, then perform the initialization. Transmit data that is initialized when the UAnTSF bit is 1 cannot be guaranteed.	p. 740	<input type="checkbox"/>
			UART reception	Be sure to read the UAnRX register even when a reception error occurs. If the UAnRX register is not read, an overrun error occurs during reception of the next data, and reception errors continue occurring indefinitely.	p. 742	<input type="checkbox"/>
				When reception is completed, read the UAnRX register after the reception completion interrupt request signal (INTUAnR) has been generated, and clear the UAnPWR or UAnRXE bit to 0. If the UAnPWR or UAnRXE bit is cleared to 0 before the INTUAnR signal is generated, the read value of the UAnRX register cannot be guaranteed.	p. 742	<input type="checkbox"/>
				If receive completion processing (INTUAnR signal generation) of UARTAn and the UAnPWR bit = 0 or UAnRXE bit = 0 conflict, the INTUAnR signal may be generated in spite of these being no data stored in the UAnRX register. To complete reception without waiting INTUAnR signal generation, be sure to clear (0) the interrupt request flag (UAnRIF) of the UAnRIC register, after setting (1) the interrupt mask flag (UAnRMK) of the interrupt control register (UAnRIC) and then set (1) the UAnPWR bit = 0 or UAnRXE bit = 0.	p. 742	<input type="checkbox"/>
			Reception errors	When an INTUAnR signal is generated, the UAnSTR register must be read to check for errors.	p. 743	<input type="checkbox"/>
				If a receive error interrupt occurs during continuous reception, read the contents of the UAnSTR register must be read before the next reception is completed, then perform error processing.	p. 744	<input type="checkbox"/>
			LIN function	When using the LIN function, fix the UAnPS1 and UAnPS0 bits of the UAnCTL0 register to 00.	p. 745	<input type="checkbox"/>
			Baud rate generator configuration	UARTAn cannot be used if the CPU clock (f <sub>CPU</sub> ) is slower than f <sub>CLK</sub> .	p. 747	<input type="checkbox"/>
			UA0CTL1 to UA5CTL1 register	Clear the UAnCTL0.UAnPWR bit to 0 before rewriting the UAnCTL1 register.	p. 749	<input type="checkbox"/>
			UA0CTL2 to UA5CTL2 register	Clear the UAnCTL0.UAnPWR bit to 0 or clear the UAnTXE and UAnRXE bits to 00 before rewriting the UAnCTL2 register.	p. 750	<input type="checkbox"/>
Baud rate error	The baud rate error during transmission must be within the error tolerance on the receiving side.	p. 752	<input type="checkbox"/>			

Chapter	Classification	Function	Details of Function	Cautions	Page
Chapter 15	Soft	Asynchronous serial interface A (UARTA)	Baud rate error	The baud rate error during reception must satisfy the range indicated in (5) Allowable baud rate range during reception.	p. 752 <input type="checkbox"/>
			When the clock supply to UARTAn is stopped	When the clock supply to UARTAn is stopped (for example, in IDLE1, IDLE2, or STOP mode), the operation stops with each register retaining the value it had immediately before the clock supply was stopped. The TXDAn pin output also holds and outputs the value it had immediately before the clock supply was stopped. However, the operation is not guaranteed after the clock supply is resumed. Therefore, after the clock supply is resumed, the circuits should be initialized by setting the UAnCTL0.UAnPWR, UAnCTL0.UAnRXEn, and UAnCTL0.UAnTXEn bits to 000.	p. 757 <input type="checkbox"/>
			RXDA1 pin KR7 pin	The RXDA1 and KR7 pins must not be used at the same time. In the V850E/SK3-H, the RXDA1 and KR7 pins are assigned to two ports each, and cannot be used at the same time at different ports. To use the RXDA1 pin, set the KRM.KRM7 bit of the KR7 pin to 0. To use the KR7 pin, set the UA1CTL0.UA1RXE bit to 0 (it is recommended to set the PFC91 bit to 1 and PFCE91 bit to 0 when using the KR7 pin at P91).	p. 757 <input type="checkbox"/>
			Error during DMA transfer	In UARTAn, the interrupt caused by a communication error does not occur. When performing the transfer of transmit data and receive data using DMA transfer, error processing cannot be performed even if errors (parity, overrun, framing) occur during transfer. Either read the UAnSTR register after DMA transfer has been completed to make sure that there are no errors, or read the UAnSTR register during communication to check for errors.	p. 757 <input type="checkbox"/>
			UARTAn startup sequence	Start up the UARTAn in the following sequence. <1> Set the UAnCTL0.UAnPWR bit to 1. <2> Set the ports. <3> Set the UAnCTL0.UAnTXE bit to 1, UAnCTL0.UAnRXE bit to 1.	p. 757 <input type="checkbox"/>
			UARTAn stop sequence	Stop the UARTAn in the following sequence. <1> Set the UAnCTL0.UAnTXE bit to 0, UAnCTL0.UAnRXE bit to 0. <2> Set the ports and set the UAnCTL0.UAnPWR bit to 0 (it is not a problem if port setting is not changed).	p. 757 <input type="checkbox"/>
			Writing the same value to the UAnTX register in transmit mode	In transmit mode (UAnCTL0.UAnPWR bit = 1 and UAnCTL0.UAnTXE bit = 1), do not overwrite the same value to the UAnTX register by software because transmission starts by writing to this register. To transmit the same value continuously, overwrite the same value.	p. 757 <input type="checkbox"/>
			Continuous transmission	In continuous transmission, the communication rate from the stop bit to the next start bit is extended 2 base clocks more than usual. However, the reception side initializes the timing by detecting the start bit, so the reception result is not affected.	p. 757 <input type="checkbox"/>
			Switching DMA transfer start factor	(a) Switching DMA transfer start factor between INTUA1R and INTIIC2 signals Setting the DMA transfer start factor to other than the combinations described in 15.8 (8) (a) <1> to <3> is prohibited. For details, see Table 22-1 DMA Transfer Start Factors.	p. 758 <input type="checkbox"/>
				(b) Switching DMA transfer start factor between INTUA2R and INTIIC0 signals Setting the DMA transfer start factor to other than the combinations described in 15.8 (8) (b) <1> to <3> is prohibited. For details, see Table 22-1 DMA Transfer Start Factors.	p. 758 <input type="checkbox"/>
Chapter 16	Soft	Asynchronous serial interface B (UARTB)	UB0CTL0 and UB1CTL0 registers	When using UARTBn, set the external pins related to the UARTBn function in the alternate-function mode, set UARTBn control register 2 (UBnCTL2). Then set the UBnPWR bit to 1 before setting the other bits.	p. 764 <input type="checkbox"/>

Chapter	Classification	Function	Details of Function	Cautions	Page
Chapter 16	Soft	Asynchronous serial interface B (UARTB)	UB0CTL0 and UB1CTL0 registers	Be sure to input a high level to the RXDBn pin when setting the external pins related to the UARTBn function in the alternate-function mode. If a low level is input, it is judged that a falling edge is input after the UBnRXE bit has been set to 1, and reception may be started.	p. 764 <input type="checkbox"/>
			UB0STR and UB1STR registers	Be sure to set bits 4 to 6 to "0".	p. 768 <input type="checkbox"/>
			UB0CTL2 and UB1CTL2 registers	When rewriting the UBnBRS15 to UBnBRS0 bits of this register, set the UBnCTL0.UBnTXE and UBnCTL0.UBnRXE bits to 0 or clear the UBnCTL0.UBnPWR bit to 0.	p. 770 <input type="checkbox"/>
			UB0TX and UB1TX, UB0RXAP and UB1RXAP, UB0RX and UB1RX, UB0FIS0, and UB1FIS0, UB0FIS1, and UB1FIS1 registers	Accessing the UBnTX, UBnRXAP, UBnRX, UBnFIS0, or UBnFIS1 register is prohibited in the following statuses. For details, refer to 3.4.9 (2) Accessing specific on-chip peripheral I/O registers. <ul style="list-style-type: none"> <li>• When the CPU operates with the subclock and the main clock oscillation is stopped</li> <li>• When the CPU operates with the internal oscillation clock</li> </ul>	pp. 771, 772, 781, 782 <input type="checkbox"/>
			UB0RXAP, UB1RXAP, UB0RX, UB1RX registers	When no reception error has occurred in the FIFO mode, the receive data of the UBnRXAP register can be read successively by reading the lower 8 bits of the UBnRXAP register in 8-bit (byte) units. An 8-bit access to the higher 8 bits is prohibited. If they are accessed, the operation is not guaranteed.	p. 772 <input type="checkbox"/>
			UB0FIC0, UB1FIC0 registers	After transmit FIFO is cleared (UBnTFC bit = 1), accessing the registers related to UARTBn is prohibited for the duration of four cycles of f <sub>XP</sub> or until clearing the UBnTFC bit (automatic recovery) is confirmed by reading the UBnFIC0 register. If these registers are accessed, the operation is not guaranteed.	p. 775 <input type="checkbox"/>
			UB0FIC0, UB1FIC0 registers	Be sure to select the single mode when writing a transmit data or reading a received data by using the DMA control. In FIFO mode, the use of the DMA control is prohibited.	p. 775 <input type="checkbox"/>
				Be sure to set bits 4 to 6 to "0".	p. 775 <input type="checkbox"/>
				After receive FIFO (UBnRXAP) is cleared (UBnRFC bit = 1), accessing the registers related to UARTBn is prohibited for the duration of four cycles of f <sub>XP</sub> or until clearing the UBnRFC bit (automatic recovery) is confirmed by reading the UBnFIC0 register. If these registers are accessed, the operation is not guaranteed.	p. 776 <input type="checkbox"/>
			UB0FIC1 and UB1FIC1 registers	Be sure to set bits 5 and 6 to "0".	p. 778 <input type="checkbox"/>
			UB0FIC2 and UB1FIC2 registers	Be sure to set the UBnCTL0.UBnTXE bit (to disable transmission) and UBnCTL0.UBnRXE bit (to disable reception) to 0 before writing data to the UBnFIC2 register. If data is written to the UBnFIC2 register with the UBnTXE or UBnRXE bit set to 1, the operation is not guaranteed.	p. 779 <input type="checkbox"/>
				Be sure to set bits 4 to 7 and 12 to 15 to "0".	p. 779 <input type="checkbox"/>
			UB0FIS1 and UB1FIS1 registers	The values of the UBnTB4 to UBnTB0 bits are reflected after transmit data has been written to the UBnTX register and then time of two cycles of f <sub>XP</sub> has passed. Therefore, care must be exercised when referencing the UBnFIS1 register after transmit data has been written to the UBnTX register.	p. 782 <input type="checkbox"/>

Chapter	Classification	Function	Details of Function	Cautions	Page
Chapter 16	Soft	Asynchronous serial interface B (UARTB)	FIFO transmission completion interrupt request signal (INTUBnTIF)	If the FIFO transmission completion interrupt request signal is generated (all transmit data are not transmitted) because writing the next transmit data to transmit FIFO is delayed, do not clear the FIFO.	p. 785 <input type="checkbox"/>
			Single mode/ FIFO mode	Be sure to select the single mode when writing a transmit data or reading a received data by using the DMA control. In FIFO mode, the use of the DMA control is prohibited.	p. 787 <input type="checkbox"/>
			Transmit operation	Setting the UBnCTL0.UBnTXE bit to 1 before writing transmit data to transmit FIFO in the FIFO mode is prohibited. The operation is not guaranteed if this setting is made.	p. 792 <input type="checkbox"/>
			Continuous transmission operation	Be sure to check whether the transmission has been completed before performing initialization during the transmission processing (UBnSTR.UBnTSF bit = 0, but it can be checked by the generation of the FIFO transmission completion interrupt request signal (INTUBnTIF) in the FIFO mode.)	p. 795 <input type="checkbox"/>
				Be sure to select the single mode when writing a transmit data or reading a received data by using the DMA control. In FIFO mode, the use of the DMA control is prohibited.	pp. 795, 818 <input type="checkbox"/>
			Receive operation	If the pointer mode is specified in the FIFO mode and if as many data as the number of bytes stored in receive FIFO are read by referencing the UBnFIS0 register, no data may be stored in receive FIFO (UBnFIS0.UBnRB4 to UBnFIS0.UBnRB0 bits = 00000) even though the reception completion interrupt request signal (INTUBnTIR) has occurred. In this case, do not read data from receive FIFO. Be sure to read data from receive FIFO after confirming that the number of bytes stored in receive FIFO = 1 byte or more (UBnRB4 to UBnRB0 bits = other than 00000).	pp. 796, 819 <input type="checkbox"/>
				Be sure to select the single mode when reading a received data by using the DMA control. In FIFO mode, use of the DMA control is prohibited.	pp. 796, 818 <input type="checkbox"/>
			Reception Completion Interrupt Request Signal (INTUBnTIR)	Be sure to read all the data (the number of data indicated by the UBnFIS0.UBnRB4 to UBnFIS0.UBnRB0 bits) stored in the receive data register n (UBnRX register in the single mode or receive FIFO in the FIFO mode (UBnRXAP register)) even when a reception error occurs. Unless the receive data register is read, an overrun error occurs when the next data is received, causing the reception error status to persist. If the pending mode is specified in the FIFO mode, however, be sure to clear the FIFO (UBnFIC0.UBnRFC bit = 1) after reading the data stored in receive FIFO. In the FIFO mode, the FIFO can be cleared even without reading the data stored in receive FIFO. If a parity error or framing error occurs in the FIFO mode, the UBnRXAP register can be read in 16-bit (halfword) units.	p. 798 <input type="checkbox"/>
			Baud rate error	Make sure that the baud rate error during transmission does not exceed the allowable error of the reception destination.	p. 804 <input type="checkbox"/>
				Make sure that the baud rate error during reception is within the allowable baud rate range during reception, which is described in paragraph (4).	pp. 804, 806 <input type="checkbox"/>
Example of reception error processing flow in FIFO mode	Reception can be continued by completing this control flow before reception of the next data is completed. Extract the receive data and check if a reception error has occurred before receive FIFO becomes empty. Note that this control flow is valid only when a parity error or a framing error occurs. If an overflow error occurs, receive FIFO must be cleared (UBnFIC0.UBnRFC bit = 1). If the next data is received before this control flow is completed, a reception error interrupt request signal (INTUBnTIRE) may occur even if the data has been received correctly.	p. 817 <input type="checkbox"/>			

Chapter	Classification	Function	Details of Function	Cautions	Page
Chapter 16	Soft	Asynchronous serial interface B (UARTB)	When supply clock to UARTBn is stopped	When the supply of clocks to UARTBn is stopped (for example, IDLE and STOP modes), operation stops with each register retaining the value it had immediately before the supply of clocks was stopped. The TXDBn pin output also holds and outputs the value it had immediately before the supply of clocks was stopped. However, operation is not guaranteed after the supply of clocks is restarted. Therefore, after the supply of clocks is restarted, the circuits should be initialized by setting the UBnPWR bit = 0, UBnRXE bit = 0, and UBnTXE bit = 0.	p. 818 <input type="checkbox"/>
			Initialization during continuous transmission in single mode and during continuous transmission (pending mode/pointer mode) in FIFO mode	Confirm that the UBnSTR.UBnTSF bit is 0 before executing initialization during transmission processing. (Initialization during continuous transmission (pending mode/pointer mode) in FIFO mode this can also be done by checking the FIFO transmission completion interrupt request signal (INTUBnTIF)). If initialization is executed while the UBnTSF bit is 1, the transmit data is not guaranteed.	pp. 818, 819 <input type="checkbox"/>
			Switching DMA transfer start factor	In the V850E/SJ3-H and V850E/SK3-H, the INTUB0TIR and INTTQ0OV signals, INTUB0TIT and INTTP0OV signals, INTUB1TIR and INTTP1OV signals, and INTUB1TIT and INTTP2OV signals, which are the DMA transfer start factors, share the same pin, respectively, and they cannot be used at the same time. To use the INTUB0TIR, INTUB0TIT, INTUB1TIR, or INTUB1TIT signal as the DMA transfer start factor, set the option byte (000007AH) (see CHAPTER 33 OPTION BYTE FUNCTION) DTFROB0 bit = 1. In this case, the INTTQ0OV, INTTP0OV, INTTP1OV, and INTTP2OV signals cannot be used as the DMA transfer start factor. For details, see Table 22-1 DMA Transfer Start Factors.	p. 819 <input type="checkbox"/>
Chapter 17	Soft	3-wire variable-length serial I/O B (CSIB)	Port settings during operation	Do not switch port settings during operation. Also, be sure to disable operation of unused units for which port settings are not made.	pp. 821, 823 <input type="checkbox"/>
			CB0CTL0 to CB5CTL0 registers	To forcibly suspend transmission/reception, clear the CBnPWR bit instead of the CBnTXE and CBnRXE bits to 0. At this time, the clock output is stopped.	p. 828 <input type="checkbox"/>
				Be sure to set bits 3 and 2 to "0".	p. 828 <input type="checkbox"/>
			CB0CTL1 to CB5CTL1 registers	The CBnCTL1 register can be rewritten only when the CBnCTL0.CBnPWR bit = 0.	p. 831 <input type="checkbox"/>
			CB0CTL1 to CB5CTL1 registers	The CBnCTL2 register can be rewritten only when the CBnCTL0.CBnPWR bit = 0 or when both the CBnTXE and CBnRXE bits = 0.	p. 833 <input type="checkbox"/>
			CB0STR to CB5STR registers	In single transfer mode, writing to the CBnTX register with the CBnTSF bit set to 1 is ignored. This has no influence on the operation during transfer.	p. 835 <input type="checkbox"/>
			Continuous transfer mode (master mode, transmission mode)	In continuous transmission mode, the reception completion interrupt request signal (INTCBnR) is not generated.	p. 853 <input type="checkbox"/>
			Continuous transfer mode (slave mode, transmission mode)	In continuous transmission mode, the reception completion interrupt request signal (INTCBnR) is not generated.	p. 862 <input type="checkbox"/>



Chapter	Classification	Function	Details of Function	Cautions	Page
Chapter 17	Soft	3-wire variable-length serial I/O B (CSIB)	Clock timing	In single transfer mode, writing to the CBnTX register with the CBnTSF bit set to 1 is ignored. This has no influence on the operation during transfer.	pp. 871, 872 <input type="checkbox"/>
			PRSM1 to PRSM3 registers	Do not rewrite the PRSMm register during operation.	p. 875 <input type="checkbox"/>
				Set the PRSMm register before setting the BGCEm bit to 1. Be sure to set bits 2, 3, and 5 to 7 to "0".	p. 875 <input type="checkbox"/>
			PRSCM1 to PRSCM3 registers	Do not rewrite the PRSCMm register during operation.	p. 876 <input type="checkbox"/>
				Set the PRSCMm register before setting the PRSMm.BGCEm bit to 1.	p. 876 <input type="checkbox"/>
			Baud rate generation	Set f <sub>BRGM</sub> to 8 MHz or lower.	p. 876 <input type="checkbox"/>
			When transferring transmit data and receive data using DMA transfer	When transferring transmit data and receive data using DMA transfer, error processing cannot be performed even if an overrun error occurs during serial transfer. Check that the no overrun error has occurred by reading the CBnSTR.CBnOVE bit after DMA transfer has been completed.	p. 877 <input type="checkbox"/>
			CBnCTL0 to CBnCTL2 registers	In regards to registers that are forbidden from being rewritten during operations (CBnCTL0.CBnPWR bit is 1), if rewriting has been carried out by mistake during operations, set the CBnCTL0.CBnPWR bit to 0 once, then initialize CSIBn. Registers to which rewriting during operation are prohibited are shown below. • CBnCTL0 register: CBnTXE, CBnRXE, CBnDIR, CBnTMS bits • CBnCTL1 register: CBnCKP, CBnDAP, CBnCKS2 to CBnCKS0 bits • CBnCTL2 register: CBnCL3 to CBnCL0 bits	p. 877 <input type="checkbox"/>
Communication type 2 or 4	When using the single transfer mode with communication type 2 or 4 (CBnDAP bit = 1), pay particular attention to the following. • To start the next transmission, confirm that CBnTSF bit = 0 and then write the transmit data to the CBnTX register. • To perform the next reception continuously when reception-only communication (CBnTXE bit = 0, CBnRXE bit = 1) is set, confirm that CBnTSF bit = 0 and then read the CBnRX register. Or, use the continuous transfer mode instead of the single transfer mode. Use of the continuous transfer mode is recommended especially when using DMA.	p. 877 <input type="checkbox"/>			
Chapter 18	Soft	3-wire variable-length serial I/O E (CSIE)	Port settings during operation	Do not switch port settings during operation. Be sure to disable operation of the unit which does not perform the port setting and is not being used.	p. 879 <input type="checkbox"/>
			CE0RX0, CE1RX0 registers	Because the values of the CEnFLF, CEnEMF, CEnTSF, CEnSFP3 to CEnSFP0 bits may change at any time during transfer, their values during transfer may differ from the actual values. Especially, use the CEnTSF bit independently (do not use this bit in relation with the other bits). To detect the end of transfer by the CEnSTR register, check to see if the CEnEMF bit is 1 after the data to be transferred has been written to the CSIBUFn register.	p. 883 <input type="checkbox"/>
			CE0TX0, CE1TX0, CE0CTL0, CE1CTL0, CE0STR, CE1STR registers	Accessing the CEnTX0, CEnCTL0, or CEnSTR register is prohibited in the following statuses. For details, refer to 3.4.9 (2) Accessing specific on-chip peripheral I/O registers. • When the CPU operates with the subclock and the main clock oscillation is stopped • When the CPU operates with the internal oscillation clock	pp. 884, 886, 892 <input type="checkbox"/>
			CE0CTL0, CE1CTL0 registers	Be sure to clear bits 0 and 1 to "0".	p. 886 <input type="checkbox"/>

Chapter	Classification	Function	Details of Function	Cautions	Page
Chapter 18	Soft	3-wire variable-length serial I/O E (CSIE)	CE0CTL2, CE1CTL2 registers	Be sure to clear bits 7 to 4 to "0".	p. 890 <input type="checkbox"/>
			CE0CTL3, CE1CTL3 registers	Be sure to clear bits 7 to 4 to "0".	p. 891 <input type="checkbox"/>
			CE0STR, CE1STR registers	Because the values of the CEnFLF, CEnEMF, CEnTSF, CEnSFP3 to CEnSFP0 bits may change at any time during transfer, their values during transfer may differ from the actual values. Especially, use the CEnTSF bit independently (do not use this bit in relation with the other bits). To detect the end of transfer by the CEnSTR register, check to see if the CEnEMF bit is 1 after the data to be transferred has been written to the CSIBUFn register.	p. 892 <input type="checkbox"/>
			Baud rate	If the CEnCTL1.CEnCKS2 to CEnCTL1.CEnCKS0 bits are cleared to 000, setting the CEnCTL1.CEnMDL2 to CEnCTL1.CEnMDL0 bits to 001 is prohibited.	p. 896 <input type="checkbox"/>
			Single mode	Be sure to confirm that the CEnSTR.CEnFLF register is 0 when writing data to the CEnTX0 register. Even if data is written to this register when CEnFLF bit is 1, the CSIBUFn overflow interrupt (INTCEnTIOF) is output, and the written data is ignored.	pp. 908, 925 <input type="checkbox"/>
			Continuous mode	The CEnSTR register is in the same status when transfer data is written (before start of transfer) after the CSIBUFn pointer is cleared (CEnSTR.CEnPCT bit = 1) and when 16 data have been transferred (CEnSTR.CEnFLF bit = 0, CEnSTR.CEnEMF bit = 1, CEnSTR.CEnSFP3 to CEnSTR.CEnSFP0 bits = 0000).	pp. 911, 925 <input type="checkbox"/>
			Delay control of transmission/reception completion interrupt (INTCEnT)	If the CEnCTL0.CEnSIT bit is set to 1 in the continuous mode (CEnCTL0.CEnTMS bit = 1), the INTCEnT interrupt is not output at the end of data other than the last data set by the CEnCTL3.CEnSFN3 to CEnCTL3.CEnSFN0 bits, but a delay of half a clock (1/2 serial clock) can be inserted between each data transfer.	p. 915 <input type="checkbox"/>
			$\overline{\text{SCKEn}}$ pin output	If the CEnCKP bit is set to 1 in the master mode (CEnCKS2 to CEnCKS0 bits are other than 111), the $\overline{\text{SCKEn}}$ pin outputs a low level when it is inactive. If the CEnCTL0.CEnTXE bit is cleared to 0 (disabling transmission) and CEnRXE bit is cleared to 0 (disabling reception), the $\overline{\text{SCKEn}}$ pin outputs a high level. Therefore, take the measures described in <1> to <7> in the caution of Table 18-9 to fix the $\overline{\text{SCKEn}}$ pin to low level when CSIEn is not used. Because the register set values <1> and <2> are retained, control can be performed only by <3> to <7> once they have been set.	p. 916 <input type="checkbox"/>
			Stopping CSIEn	The CSIEn unit is reset and CSIEn is stopped when the CEnCTL0.CEnPWR bit is cleared to 0. To operate CSIEn, first set the CEnPWR bit to 1. Usually, before clearing the CEnPWR bit to 0, clear both the CEnTXE and CEnRXE bits to 0 (after the end of transfer).	p. 925 <input type="checkbox"/>
Enabling transfer	Be sure to write 1 to the CEnSTR.CEnPCT bit to clear all the CSIBUFn pointers to 0 before enabling transfer by setting the CEnCTL0.CEnPWR bits to 1. If the CEnTXE or CEnRXE bit is set to 1 without clearing the pointers, and if the previously transferred data remains in the CSIBUFn register, transferring that data is immediately started. If transfer data is set to the CSIBUFn register before transfer is enabled, transfer is started as soon as the CEnTXE or CEnRXE bit is set to 1.	p. 925 <input type="checkbox"/>			

Chapter	Classification	Function	Details of Function	Cautions	Page
Chapter 18	Soft	3-wire variable-length serial I/O E (CSIE)	Caution on CENCTL0 register setting	Be sure to set the port pins related to the CSIE function to the alternate-function mode before using CSIE. Then set the CENPWR bit to 1 before setting the other bits.	p. 925 <input type="checkbox"/>
			Switching DMA transfer start factor	In the V850E/SJ3-H and V850E/SK3-H, DMA transfer start factor signals INTCE0T and INTERR are shared and cannot be used at the same time. This is also the case for DMA transfer start factor signals INTCE1T and INTSTA. When using the INTCE0T or INTCE1T signal as the DMA transfer start factor, set the DTFROB0 bit to 1 using the option byte 0000007AH (refer to CHAPTER 33 OPTION BYTE FUNCTION for details). In this case, the INTERR and INTSTA signals cannot be used as DMA transfer start factors. For details, see Table 22-1 DMA Transfer Start Factors.	p. 925 <input type="checkbox"/>
Chapter 19	Soft	I <sup>2</sup> C bus	I <sup>2</sup> C bus	Set pins to N-ch open-drain output.	p. 926 <input type="checkbox"/>
			Port settings during operation	Do not switch port settings during operation. Also, be sure to disable operation of unused units for which port settings are not made.	pp. 928, 930 <input type="checkbox"/>
			IICC0 to IICC5 registers	After enabling the I <sup>2</sup> Cn operation (IICEn bit = 1), immediately set the LRELn bit to 1 with a bit manipulation instruction.	p. 937 <input type="checkbox"/>
			IICS0 to IICS5 registers	Accessing the IICSn register is prohibited in the following statuses. For details, refer to 3.4.9 (2) Accessing specific on-chip peripheral I/O registers. <ul style="list-style-type: none"> <li>• When the CPU operates with the subclock and the main clock oscillation is stopped</li> <li>• When the CPU operates with the internal oscillation clock</li> </ul>	p. 941 <input type="checkbox"/>
			IICF0 to IICF5 registers	Write the STCENn bit only when operation is stopped (IICEn bit = 0).	p. 945 <input type="checkbox"/>
				When the STCENn bit = 1, the bus released status (IICBSYn bit = 0) is recognized regardless of the actual bus status immediately after the I <sup>2</sup> Cn bus operation is enabled. Therefore, to issue the first start condition (STTn bit = 1), it is necessary to confirm that the bus has been released, so as to not disturb other communications.	p. 945 <input type="checkbox"/>
			IICCL0 to IICCL5 registers	Be sure to set bits 7 and 6 of IICCLn to 0.	p. 946 <input type="checkbox"/>
			Status during arbitration and interrupt request signal generation timing	When there is a possibility that arbitration will occur, set the SPIEn bit to 1 for master device operation.	p. 990 <input type="checkbox"/>
			When IICFn.STCENn bit = 0	Immediately after the I <sup>2</sup> C0n operation is enabled, the bus communication status (IICFn.IICBSYn bit = 1) is recognized regardless of the actual bus status. To execute master communication in the status where a stop condition has not been detected, generate a stop condition and then release the bus before starting the master communication. Use the following sequence for generating a stop condition. <1> Set the IICCLn register. <2> Set the IICFn.IICEn bit. <3> Set the IICFn.SPTn bit.	p. 996 <input type="checkbox"/>
When IICFn.STCENn bit = 1	Immediately after I <sup>2</sup> C0n operation is enabled, the bus released status (IICBSYn bit = 0) is recognized regardless of the actual bus status. To generate the first start condition (IICFn.STTn bit = 1), it is necessary to confirm that the bus has been released, so as to not disturb other communications.	p. 996 <input type="checkbox"/>			

Chapter	Classification	Function	Details of Function	Cautions	Page
Chapter 19	Soft	I <sup>2</sup> C bus	While communications with other devices are in progress	When the IICn.IICEn bit of the V850E/SJ3-H, V850E/SK3-H is set to 1 while communications with other devices are in progress, the start condition may be detected depending on the status of the communication line. Be sure to set the IICn.IICEn bit to 1 when the SCL0n and SDA0n lines are high level.	p. 996 <input type="checkbox"/>
			Setting operation clock frequency	Determine the operation clock frequency by the IICCLn, IICXn, and OCKSm registers before enabling the operation (IICn.IICEn bit = 1). To change the operation clock frequency, clear the IICn.IICEn bit to 0 once.	p. 996 <input type="checkbox"/>
			IICn.STTn, SPTn bit	After the IICn.STTn and IICn.SPTn bits have been set to 1, they must not be reset without being cleared to 0 first.	p. 996 <input type="checkbox"/>
			Transmission reservation	If transmission has been reserved, set the IICn.SPIEn bit to 1 so that an interrupt request is generated by the detection of a stop condition. After an interrupt request has been generated, the wait state will be released by writing communication data to I <sup>2</sup> Cn, then transferring will begin. If an interrupt is not generated by the detection of a stop condition, transmission will halt in the wait state because an interrupt request was not generated. However, it is not necessary to set the SPIEn bit to 1 for the software to detect the IICn.MSTSn bit.	p. 996 <input type="checkbox"/>
			Switching DMA transfer start factor between INTUA1R and INTIIC2 signals	Setting the DMA transfer start factor to other than the specified combinations is prohibited. For details, refer to 19.15 (7) (a) <1> to <3>. For details, see Table 22-1 DMA Transfer Start Factors.	p. 997 <input type="checkbox"/>
			Switching DMA transfer start factor between INTUA2R and INTIIC0 signals	Setting the DMA transfer start factor to other than the specified combinations is prohibited. For details, refer to 19.15 (7) (b) <1> to <3>. For details, see Table 22-1 DMA Transfer Start Factors.	p. 997 <input type="checkbox"/>
			Master operation in single master system	Release the I <sup>2</sup> C0n bus (SCL0n, SDA0n pins = high level) in conformity with the specifications of the product in communication. For example, when the EEPROM outputs a low level to the SDA0n pin, set the SCL0n pin to the output port and output clock pulses from that output port until when the SDA0n pin is constantly high level.	p. 999 <input type="checkbox"/>
Chapter 20	Soft	IEBus controller	Effective transfer rate	Different modes (mode 1, mode 2) must not be mixed on one IEBus.	p. 1014 <input type="checkbox"/>
			Data field	Do not operate master reception in broadcast communication, because the slave unit cannot be defined and data transfer cannot be performed correctly.	p. 1024 <input type="checkbox"/>
			BCR register	While IEBus is operating as the master, writing to the BCR register (including bit manipulation instructions) is disabled until either the end of that communication or frame, or until communication is stopped by the occurrence of an arbitration-loss communication error. Master requests cannot therefore be multiplexed. However, the case when communication has been forcibly stopped (ENIEBUS flag = 0) is not problem.	p. 1032 <input type="checkbox"/>

Chapter	Classification	Function	Details of Function	Cautions	Page
Chapter 20	Soft	IEBus controller	BCR register	If a bit manipulation instruction for the BCR register conflicts with a hardware reset of the MSTRQ bit, the BCR register may not operate normally. The following countermeasures are recommended in this case. <ul style="list-style-type: none"> <li>• Because the hardware reset is instigated in the acknowledgment period of the slave address field, be sure to observe Caution 1 of (b) Master request flag (MSTRQ) below.</li> <li>• Be sure to observe the caution above regarding writing to the BCR register.</li> </ul>	p. 1032 <input type="checkbox"/>
				Be sure to set bits 0 to 2 to "0".	p. 1032 <input type="checkbox"/>
			Communication enable flag (ENIEBUS)	Before setting the ENIEBUS bit (1), the following registers must be set depending on the mode of communication to be started.	p. 1033 <input type="checkbox"/>
			Master request flag (MSTRQ)	If the IEBus controller has lost in arbitration, issue the master request again by software. In doing so, set (1) the MSTRQ bit at a timing other than that illustrated below.	p. 1034 <input type="checkbox"/>
				When a master request has been sent and bus mastership acquired, do not set the MSTRQ, ENSLVTX, or ENSLVRX bit until the end of communication (i.e. the communication end flag (ISR.ENDTRNS bit) or frame end flag (ISR.ENDFRAM bit) is set (1)) as setting these flags disables interrupt request signal generation. However, these flags can be set if communication has been aborted.	p. 1034 <input type="checkbox"/>
			Broadcast request flag of BCR register	When requesting broadcast communication, always set (1) the ALLRQ bit, then the MSTRQ bit.	p. 1034 <input type="checkbox"/>
			Slave transmission enable flag of BCR register	The ENSLVTX bit must be set before the parity bit in the control field is received.	p. 1035 <input type="checkbox"/>
				Clear the ENSLVTX bit (0) before setting the MSTRQ bit (1) when making a master request. This is to avoid transmission of the data of the DR register that tries master transmission if the controller loses in arbitration after master operation and if slave transmission is requested by the master.	p. 1035 <input type="checkbox"/>
			Slave reception enable flag of BCR register	The ENSLVRX bit must be set before the parity bit in the control field is received.	p. 1035 <input type="checkbox"/>
			PSR register	Do not set the PSR register while communication is enabled (BCR.ENIEBUS bit = 1).	p. 1036 <input type="checkbox"/>
				Be sure to clear bits 5 to 0 to "0".	p. 1036 <input type="checkbox"/>
			USR register	Be sure to set bits 0, 1, and 7 to "0".	p. 1038 <input type="checkbox"/>
			Arbitration result flag of USR register	The flag is cleared (0) at the detection timing of the start bit if the other unit outputs the start bit earlier and the unit does not output the start bit after the master request.	p. 1039 <input type="checkbox"/>
			Lock status flag of USR register	Lock specification/release is not possible in broadcast communication. In the lock status, individual communication from a unit other than the one that requests locking is not acknowledged. However, even communication from a unit other than the one that requests locking is acknowledged as long as the communication is a slave status request.	p. 1040 <input type="checkbox"/>
			ISR register	Be sure to set bits 0, 1, and 7 to "0".	p. 1041 <input type="checkbox"/>
ESR register	Each bit can only be cleared (0). It cannot be set (1) even if 1 is written to it.	p. 1044 <input type="checkbox"/>			
	The value of the ESR register is updated when an error occurs. If the ESR register is read at this time, however, an undefined value is read. It is recommended to read the ESR register in error interrupt servicing.	p. 1044 <input type="checkbox"/>			

Chapter	Classification	Function	Details of Function	Cautions	Page
Chapter 20	Soft	IEBus controller	ESR register	If a communication error occurs, the IEBus controller returns to the default status and makes preparation for communication. If communication is started without the error corrected, the error flag accumulates the error. Correct the error before the next communication is started.	p. 1044 <input type="checkbox"/>
				Be sure to set bit 1 to "0".	p. 1044 <input type="checkbox"/>
			Overrun error occurrence flag of ESR register	The overrun status is cleared only when the DR register is read and when the system is reset. Therefore, be sure to read the DR register in the communication error interrupt servicing program.	p. 1047 <input type="checkbox"/>
				The next data cannot be transmitted in the overrun status if it is 2 bytes or more. Because the data request interrupt request signal (INTIE1) does not occur, the transmit data cannot be set and an underrun error occurs. Therefore, be sure to execute transmission after clearing the overrun status.	p. 1047 <input type="checkbox"/>
			Timing of write error occurrence	Even when the WERR bit is set (1), the INTIE1 interrupt request signal may be generated.	p. 1048 <input type="checkbox"/>
			UAR register	Do not set the UAR register while communication is enabled (BCR.ENIEBUS bit = 1).	p. 1049 <input type="checkbox"/>
			SAR register	Be sure to set the SAR register only at the following timing. <ul style="list-style-type: none"> <li>• When the BCR.ENIEBUS bit is 0</li> <li>• Between when the ENIEBUS bit becomes 1 and the first master request is sent (the BCR.MSTRQ bit is set to 1)</li> <li>• When the ENIEBUS bit is 1, and the MSTRQ bit is 0 and between either the end of that communication, frame, or error and the next master request (the MSTRQ bit is set to 1)</li> </ul>	p. 1049 <input type="checkbox"/>
			PAR register	The PAR register stores an address value if the parity is correct and the unit is not locked when the parity period of the master address field expires. If the PAR register is read at this time, an undefined value is read.	p. 1050 <input type="checkbox"/>
			RSA register	The RSA register stores an address value if the parity is correct and the unit is not locked when the parity period of the slave address field expires. If the RSA register is read at this time, an undefined value is read.	p. 1050 <input type="checkbox"/>
			CDR register	Because the slave unit must judge whether the received data is a "command" or "data", read the value of the CDR register after completing communication.	p. 1051 <input type="checkbox"/>
			CDR register	If the master unit sets an undefined value, the slave unit returns the NACK signal and communication is aborted. During broadcast communication, the master unit ignores the acknowledge bit and continues communication. Therefore, do not set an undefined value.	p. 1051 <input type="checkbox"/>
				Be sure to set bits 4 to 7 to "0".	p. 1051 <input type="checkbox"/>
			DLR register	When the master issues a request (0H, 4H, 5H, or 6H) for transmission of a slave status or a lock address (higher 4 bits and lower 8 bits), 01H is transmitted as the telegraph length regardless of the contents of the DLR register. It is therefore not necessary to set the DLR register by software.	p. 1055 <input type="checkbox"/>
When the IEBus controller serves as a receiver unit, the DLR register stores a telegraph length if the value of the parity bit of the telegraph length field is correct. If the DLR register is read at this time, an undefined value is read.	p. 1055 <input type="checkbox"/>				
DR register	When the IEBus controller serves as a receiver unit, the DR register stores receive data if the value of the parity bit of the data field is correct. If the DR register is read at this time, an undefined value is read.	p. 1056 <input type="checkbox"/>			
FSR register	The FSR register updates the status information when an interrupt request signal is generated. If the FSR register is read at this time, however, an undefined value is read.	p. 1057 <input type="checkbox"/>			

Chapter	Classification	Function	Details of Function	Cautions	Page
Chapter 20	Soft	IEBus controller	FSR register	If another interrupt request signal is generated before the FSR register is read, the status information when the preceding interrupt occurred is updated by the status information when the new interrupt occurs. Use the FSR register only for problem analysis; do not use it with the actual software.	p. 1057 <input type="checkbox"/>
			SCR register	The SCR register is updated when the parity period of the telegraph field expires and when the ACK signal of the data field is received. If the SCR register is read at this time, however, an undefined value is read.	p. 1058 <input type="checkbox"/>
			CCR register	The maximum number of transmit bytes is preset to the CCR register when the start bit is transmitted or received, and the register is decremented when the parity period of the data field expires. If the CCR register is read at this time, however, an undefined value is read.	p. 1059 <input type="checkbox"/>
			OCKS2 register	Be sure to set bits 2 and 5 to 7 to "0".	p. 1060 <input type="checkbox"/>
			Switching DMA transfer start factor	In the V850E/SJ3-H and V850E/SK3-H, the INTERR and INTCE0T signals <sup>Note</sup> , and INTSTA and INTCE1T signals <sup>Note</sup> , which are the DMA transfer start factors, respectively share the same pin, and they cannot be used at the same time. To use INTERR or INTSTA signal as the DMA transfer start factor, set the DTFROB0 bit of the option byte 0000007AH to 0 (see CHAPTER 33 OPTION BYTE FUNCTION). In this case, the INTCE0T <sup>Note</sup> and INTCE1T <sup>Note</sup> signals cannot be used as the DMA transfer start factor. Note Not available in the μPD70F3931 (V850E/SJ3-H), 70F3932 (V850E/SJ3-H), and 70F3933 (V850E/SJ3-H) Remark For details, see Table 22-1 DMA Transfer Start Factors.	p. 1081 <input type="checkbox"/>
Chapter 21	Soft	CAN controller	CAN controller	The CAN controller is allocated in the programmable peripheral I/O area. Before using the CAN controller, enable use of the programmable peripheral I/O area by using the BPC register. For details, refer to 3.4.7 Programmable peripheral I/O registers.	p. 1082 <input type="checkbox"/>
			Arbitration field (in standard format mode)	An identifier is transmitted MSB first.	p. 1088 <input type="checkbox"/>
			Arbitration Field (in Extended Format Mode)	An identifier is transmitted MSB first.	p. 1088 <input type="checkbox"/>
			Data Length Setting	In the remote frame, there is no data field even if the data length code is not 0000B.	p. 1089 <input type="checkbox"/>
			Forced recovery operation that skips bus-off recovery sequence	This function is not defined by the CAN protocol ISO 11898. When using this function, thoroughly evaluate its effect on the network system.	p. 1102 <input type="checkbox"/>
			Initializing CAN module error counter register in initialization mode	This function is enabled only in the initialization mode. Even if the CCERC bit is set to 1 in a CAN operation mode, the CnERC and CnINFO registers are not initialized.	p. 1103 <input type="checkbox"/>
			Register	Accessing the CAN controller registers is prohibited in the following statuses. For details, refer to 3.4.9 (2) Accessing specific on-chip peripheral I/O registers. <ul style="list-style-type: none"> <li>• When the CPU operates with the subclock and the main clock oscillation is stopped</li> <li>• When the CPU operates with the internal oscillation clock</li> </ul>	p. 1148 <input type="checkbox"/>

Chapter	Classification	Function	Details of Function	Cautions	Page
Chapter 21	Soft	CAN controller	C0GMCTRL, C1GMCTRL registers	While the MBON bit is cleared (to 0), software access to the message buffers (CnMDATA0m, CnMDATA1m, CnMDATA01m, CnMDATA2m, CnMDATA3m, CnMDATA23m, CnMDATA4m, CnMDATA5m, CnMDATA45m, CnMDATA6m, CnMDATA7m, CnMDATA67m, CnMDLcM, CnMCONFm, CnMIDLm, CnMIDHm, and CnMCTRLm), or registers related to transmit history or receive history (CnLOPT, CnTGPT, CnLIPT, and CnRGPT) is disabled.	p. 1149 <input type="checkbox"/>
				To request forced shut down, clear the GOM bit to 0 immediately after the EFSD bit has been set to 1. If access to another register (including reading the CnGMCTRL register) is executed by software (interrupts including NMI) or DMA without clearing the GOM bit immediately after the EFSD bit has been set to 1, the EFSD bit is forcibly cleared to 0, and the forced shut down request is invalid.	p. 1150 <input type="checkbox"/>
				The GOM bit is cleared to 0 only in the initialization mode or immediately after the EFSD bit is set to 1.	p. 1150 <input type="checkbox"/>
				Be sure to set the GOM bit and EFSD bit separately.	p. 1150 <input type="checkbox"/>
			C0GMABT, C1GMABT registers	Before changing the normal operation mode with ABT to the initialization mode, be sure to set the CnGMABT register to the default value (0000H). After setting, confirm that the CnGMABT register is initialized to 0000H.	p. 1152 <input type="checkbox"/>
				Do not set the ABTTRG bit to 1 in the initialization mode. If the ABTTRG bit is set to 1 in the initialization mode, the operation is not guaranteed after the CAN module has entered the normal operation mode with ABT.	p. 1152 <input type="checkbox"/>
				Do not set the ABTTRG bit to 1 while the CnCTRL.TSTAT bit is set to 1. Directly confirm that the TSTAT bit = 0 before setting the ABTTRG bit to 1.	p. 1152 <input type="checkbox"/>
			C0GMABTD, C1GMABTD registers	Do not change the contents of the CnGMABTD register while the ABTTRG bit is set to 1.	p. 1154 <input type="checkbox"/>
				Be sure to set bits 4 to 7 to "0".	p. 1154 <input type="checkbox"/>
			C0MASK3L, C1MASK3L, C0MASK3H, C1MASK3H registers	Be sure to set bits 13 to 15 of the CnMASKaH register to 0.	p. 1156 <input type="checkbox"/>
			C0CTRL, C1CTRL registers	Transition to and from the CAN stop mode must be made via CAN sleep mode. A request for direct transition to and from the CAN stop mode is ignored.	p. 1159 <input type="checkbox"/>
				After releasing the power save mode, the CnGMCTRL.MBON flag must be checked before accessing the message buffer again.	p. 1159 <input type="checkbox"/>
				It may take time to change the mode to the initialization mode or power save mode. Therefore, be sure to check if the mode has been successfully changed, by reading the register value before executing the processing.	p. 1159 <input type="checkbox"/>
			C0LEC, C1LEC registers	Be sure to set bits 3 to 7 to "0".	p. 1161 <input type="checkbox"/>
			C0INFO, C1INFO registers	Be sure to set bits 5 to 7 to "0".	p. 1162 <input type="checkbox"/>
			C0INTS, C1INTS registers	The status bit of this register is not automatically cleared. Clear it (0) by software if each status must be checked in the interrupt servicing.	p. 1166 <input type="checkbox"/>
			C0BRP, C1BRP registers	The CnBRP register can be write-accessed only in the initialization mode.	p. 1167 <input type="checkbox"/>
C0MDLcM, C1MDLcM registers	Be sure to set bits 4 to 7 to "0".	p. 1178 <input type="checkbox"/>			



Chapter	Classification	Function	Details of Function	Cautions	Page
Chapter 21	Soft	CAN controller	C0MCONFm, C1MCONFm registers	Be sure to set bits 2 and 1 to "0".	p. 1180 □
			C0MIDLm, C0MIDHm, C1MIDLm, C1MIDHm registers	Be sure to write 0 to bits 14 and 13 of the CnMIDHm register.	p. 1180 □
				Be sure to arrange the ID values to be registered in accordance with the bit positions of this register. For the standard ID, shift the bit positions of ID28 to ID18 of the ID value.	p. 1180 □
			C0MCTRLm, C1MCTRLm registers	Do not set the TRQ bit and RDY bit to 1 at the same time. Be sure to set the RDY bit to 1 before setting the TRQ bit to 1.	p. 1182 □
				Do not clear the RDY bit (0) during message transmission. Follow transmission abort procedures in order to clear the RDY bit for redefinition.	p. 1182 □
				If the RDY bit is not cleared (0) even when the processing to clear it is executed, execute the clearing processing again.	p. 1182 □
				Confirm, by reading the RDY bit again, that the RDY bit has been cleared (0) before writing data to the message buffer. However, it is unnecessary to confirm that the TRQ or RDY bit has been set (1) or that the DN or MOW bit has been cleared (0).	p. 1182 □
				Be sure to set the IE and RDY bits separately.	p. 1182 □
				Do not set the DN bit to 1 by software. Be sure to write 0 to bit 10.	p. 1182 □
			C0MCTRLm, C1MCTRLm registers	If the DN bit is cleared to 0 before the arbitration field that is being received ends, the message buffer in which the data frame is being stored becomes a target destination for storing another received data frame.	p. 1182 □
				Be sure to set the TRQ and RDY bits separately.	p. 1183 □
			To redefine message buffer during transmission	When a message is received, reception filtering is performed in accordance with the ID and mask set to each receive message buffer. If the procedure in Figure 21-39 is not observed, the contents of the message buffer after it has been redefined may contradict the result of reception (result of reception filtering). If this happens, check that the ID and IDE received first and stored in the message buffer following redefinition are those stored after the message buffer has been redefined. If no ID and IDE are stored after redefinition, redefine the message buffer again.	p. 1187 □
				When a message is transmitted, the transmission priority is checked in accordance with the ID, IDE, and RTR bits set to each transmit message buffer to which a transmission request was set. The transmit message buffer having the highest priority is selected for transmission. If the procedure in Figure 21-27 is not observed, a message with an ID not having the highest priority may be transmitted after redefinition.	p. 1187 □
			Receive history list function	Even if the receive history list overflows (CnRGPT.ROVF bit = 1), the receive history can be read until no more history is left unread and the CnRGPT.RHPM bit is set (1). However, the ROVF bit is kept set (1) (= overflow occurs) until cleared (0) by software. In this status, the RHPM bit is not cleared (0), unless the ROVF bit is cleared (0), even if a new receive history is stored and written to the list. If ROVF bit = 1 and RHPM bit = 1 and the receive history list overflows, therefore, the RHPM bit indicates that no more history is left unread even if new history is received and stored.	p. 1191 □
Multi buffer receive block function	MBRB does not have a ring buffer structure. Therefore, after a message is stored in the message buffer having the highest number in the MBRB configuration, a newly received message will no longer be stored in the message buffer in the order from the lowest message buffer number.	p. 1195 □			

Chapter	Classification	Function	Details of Function	Cautions	Page
Chapter 21	Soft	CAN controller	Transmit history list function	If the TOVF bit = 1 and the THPM bit = 1 and the receive history list overflows, therefore, the THPM bit indicates that no more history is left unread even if new history is received and stored.	p. 1199 <input type="checkbox"/>
			Automatic block transmission	To resume the normal operation mode with ABT from the message buffer 0, set the ABTCLR bit to 1 while the ABTTRG bit is cleared to 0. If the ABTCLR bit is set to 1 while the ABTTRG bit is set to 1, the subsequent operation is not guaranteed.	p. 1202 <input type="checkbox"/>
				Do not set the ABTTRG bit in the initialization mode. If the ABTTRG bit is set in the initialization mode, the proper operation is not guaranteed after the mode is changed from the initialization mode to the ABT mode.	p. 1202 <input type="checkbox"/>
				Do not set the TRQ bit of the ABT message buffers to 1 by software in the normal operation mode with ABT. Otherwise, the operation is not guaranteed.	p. 1202 <input type="checkbox"/>
				Do not clear the RDY bit to 0 when the ABTTRG bit = 1.	p. 1202 <input type="checkbox"/>
				If a message is received from another node in the normal operation mode with ABT, the message may be transmitted after the time of one frame has elapsed even when CnGMABTD register = 00H.	p. 1202 <input type="checkbox"/>
			Transmission abort in normal operation mode with automatic block transmission	Be sure to abort ABT by clearing the ABTTRG bit to 0. The operation is not guaranteed if aborting transmission is requested by clearing RDY.	p. 1203 <input type="checkbox"/>
			Releasing CAN sleep mode	Even if the falling edge belongs to the SOF of a receive message, this message will not be received and stored. If the CPU has turned off the clock to the CAN while the CAN was in sleep mode, later on the CAN sleep mode will not be released and PSMODE[1:0] bits will continue to be 01B unless the clock for the CAN is provided again. In addition to this, the receive message will not be received afterwards.	p. 1206 <input type="checkbox"/>
				If a falling edge is detected at the CAN reception pin (CRXDn) while the CAN clock is supplied, the PSMODE0 bit must be cleared by software. (For details, refer to the processing in Figure 21-53.)	p. 1206 <input type="checkbox"/>
				When the CAN sleep mode is released by an event of the CAN bus, a wakeup interrupt occurs even if the event of the CAN bus occurs immediately after the mode has been changed to the sleep mode. Note that the interrupt can occur at any time.	p. 1206 <input type="checkbox"/>
			Entering CAN stop mode	To set the CAN module to the CAN stop mode, the module must be in the CAN sleep mode. To confirm that the module is in the sleep mode, check that the PSMODE1 and PSMODE0 bits = 01B, and then request the CAN stop mode. If a bus change occurs at the CAN reception pin (CRXDn) while this process is being performed, the CAN sleep mode is automatically released. In this case, the CAN stop mode transition request cannot be acknowledged (while the CAN clock is supplied, however, the PSMODE0 must be cleared by software after the bus level of the CAN reception pin (CRXDn) is changed).	p. 1207 <input type="checkbox"/>
			Receive-only mode	If only two CAN nodes are connected to the CAN bus and one of them is operating in the receive-only mode, there is no ACK on the CAN bus. Due to the missing ACK, the transmitting node will transmit an active error flag, and repeat transmitting a message frame. The transmitting node becomes error passive after transmitting the message frame 16 times (assuming that the error counter was 0 in the beginning and no other errors have occurred). When the message frame is transmitted for the 17th time, the transmitting node generates a passive error flag. The receiving node in the receive-only mode detects the first valid message frame at this point, and the VALID bit is set to 1 for the first time.	p. 1211 <input type="checkbox"/>

Chapter	Classification	Function	Details of Function	Cautions	Page
Chapter 21	Soft	CAN controller	Time stamp function	For these reasons, a data frame cannot be received in message buffer 0 when the CAN module is in the normal operation mode with ABT, because message buffer 0 must be set as a transmit message buffer. In this operation mode, therefore, the function to stop toggle of the TSOUT signal by the TSLOCK bit cannot be used.	p. 1215 <input type="checkbox"/>
			Settable bit rate combinations	The values in Table 21-22 do not guarantee the operation of the network system. Thoroughly check the effect on the network system, taking into consideration oscillation errors and delays of the CAN bus and CAN transceiver.	p. 1219 <input type="checkbox"/>
				The values in Table 21-23 do not guarantee the operation of the network system. Thoroughly check the effect on the network system, taking into consideration oscillation errors and delays of the CAN bus and CAN transceiver.	pp. 1220, 1221 <input type="checkbox"/>
				The values in Table 21-24 do not guarantee the operation of the network system. Thoroughly check the effect on the network system, taking into consideration oscillation errors and delays of the CAN bus and CAN transceiver.	pp. 1222, 1223 <input type="checkbox"/>
			Re-initialization	After setting the CAN module to the initialization mode, avoid setting the module to another operation mode immediately after. If it is necessary to immediately set the module to another operation mode, be sure to access registers other than the CnCTRL and CnGMCTRL registers (e.g., set a message buffer).	p. 1225 <input type="checkbox"/>
			Message buffer initialization	Before a message buffer is initialized, the RDY bit must be cleared.	p. 1226 <input type="checkbox"/>
				Make the following settings for message buffers not used by the application. <ul style="list-style-type: none"> <li>• Clear the CnMCTRLm.RDY, CnMCTRLm.TRQ, and CnMCTRLm.DN bits to 0.</li> <li>• Clear the CnMCONFm.MA0 bit to 0.</li> </ul>	p. 1226 <input type="checkbox"/>
			Message transmit processing	The TRQ bit should be set after the RDY bit is set.	p. 1229 <input type="checkbox"/>
				The RDY bit and TRQ bit should not be set at the same time.	p. 1229 <input type="checkbox"/>
			ABT message transmit processing	The ABTTRG bit should be set to 1 after the TSTAT bit is cleared to 0. The checking of the TSTAT bit and the setting for the ABTTRG bit to 1 must be continuous.	p. 1230 <input type="checkbox"/>
			Transmission via interrupt (using CnLOPT register)	The TRQ bit should be set after the RDY bit is set.	p. 1231 <input type="checkbox"/>
				The RDY bit and TRQ bit should not be set at the same time.	p. 1231 <input type="checkbox"/>
				Check the MBON bit at the start and end of the interrupt routine to see if the message buffer and transmit history register can be accessed, because a CAN sleep mode transition request which has been held pending may be under execution. If the MBON bit is cleared (0), stop the processing under execution. Re-execute the processing after the MBON bit is set (1) again. It is therefore recommended to cancel the CAN sleep mode transition request before executing transmission interrupt servicing.	p. 1231 <input type="checkbox"/>
			Transmission via interrupt (using CnTGPT register)	The TRQ bit should be set after the RDY bit is set.	p. 1232 <input type="checkbox"/>
				The RDY bit and TRQ bit should not be set at the same time.	p. 1232 <input type="checkbox"/>
				Check the MBON bit at the start and end of the interrupt routine to see if the message buffer and transmit history register can be accessed, because a CAN sleep mode transition request which has been held pending may be under execution. If the MBON bit is cleared (0), stop the processing under execution. Re-execute the processing after the MBON bit is set (1) again. It is therefore recommended to cancel the CAN sleep mode transition request before executing transmission interrupt servicing.	p. 1232 <input type="checkbox"/>
				If the TOVF bit is set (1) again, the transmit history list contradicts. Therefore, scan all the transmit message buffers that have completed transmission.	p. 1232 <input type="checkbox"/>
			Transmission via software polling	The TRQ bit should be set after the RDY bit is set.	p. 1233 <input type="checkbox"/>
The RDY bit and TRQ bit should not be set at the same time.	p. 1233 <input type="checkbox"/>				

Chapter	Classification	Function	Details of Function	Cautions	Page
Chapter 21	Soft	CAN controller	Transmission via software polling	Check the MBON bit at the start and end of the polling routine to see if the message buffer and transmit history register can be accessed, because a CAN sleep mode transition request which has been held pending may be under execution. If the MBON bit is cleared (0), stop the processing under execution. Re-execute the processing after the MBON bit is set (1) again.	p. 1233 <input type="checkbox"/>
				If the TOVF bit is set (1) again, the transmit history list contradicts. Therefore, scan all the transmit message buffers that have completed transmission.	p. 1233 <input type="checkbox"/>
			Transmission abort processing (other than in normal operation mode with ABT)	Execute transmission abort processing by clearing the TRQ bit, not the RDY bit.	p. 1234 <input type="checkbox"/>
				Before making a sleep mode transition request, confirm that there is no transmission request left using this processing.	p. 1234 <input type="checkbox"/>
				The TSTAT bit can be periodically checked by a user application or can be checked after the transmit completion interrupt.	p. 1234 <input type="checkbox"/>
			Transmission abort processing (other than in normal operation mode with ABT)	Do not execute a new transmission request that includes other message buffers while transmission abort processing is in progress.	p. 1234 <input type="checkbox"/>
				If data of the same message buffer are successively transmitted or if only one message buffer is used, judgments whether transmission has been successfully executed or failed may contradict. In such a case, make a judgment by using the history information of the CnTGPT register.	p. 1234 <input type="checkbox"/>
			Transmission abort processing except for ABT transmission (normal operation mode with ABT)	Execute transmission abort processing by clearing the TRQ bit, not the RDY bit.	p. 1235 <input type="checkbox"/>
				Before making a sleep mode transition request, confirm that there is no transmission request left using this processing.	p. 1235 <input type="checkbox"/>
				Do not execute a new transmission request including in the other message buffers while transmission abort processing is in progress.	p. 1235 <input type="checkbox"/>
				If data of the same message buffer are successively transmitted or if only one message buffer is used, judgments whether transmission has been successfully executed or failed may contradict. In such a case, make a judgment by using the history information of the CnTGPT register.	p. 1235 <input type="checkbox"/>
			ABT transmission abort processing (normal operation mode with ABT)	Do not set any transmission requests while ABT transmission abort processing is in progress.	pp. 1236, 1237 <input type="checkbox"/>
				Make a CAN sleep mode/CAN stop mode transition request after the ABTRG bit is cleared (after ABT mode is stopped) following the procedure shown in Figure 21-48 (a) or (b). When clearing a transmission request in an area other than the ABT area, follow the procedure shown in Figure 21-47.	pp. 1236, 1237 <input type="checkbox"/>
			Reception via interrupt (using CnLIPT register)	Check the MBON bit at the start and end of the interrupt routine to see if the message buffer and receive history register can be accessed, because a CAN sleep mode transition request which has been held pending may be under execution. If the MBON bit is cleared (0), stop the processing under execution. Re-execute the processing after the MBON bit is set (1) again. It is therefore recommended to cancel the CAN sleep mode transition request before executing reception interrupt servicing.	p. 1238 <input type="checkbox"/>
			Reception via interrupt (using CnRGPT register)	Check the MBON bit at the start and end of the interrupt routine to see if the message buffer and receive history register can be accessed, because a CAN sleep mode transition request which has been held pending may be under execution. If the MBON bit is cleared (0), stop the processing under execution. Re-execute the processing after the MBON bit is set (1) again. It is therefore recommended to cancel the CAN sleep mode transition request before executing reception interrupt servicing.	p. 1239 <input type="checkbox"/>
If the ROVF bit has been once set (1), the receive history list contradicts. Therefore, scan all the receive message buffers that have completed reception.	p. 1239 <input type="checkbox"/>				

Chapter	Classification	Function	Details of Function	Cautions	Page
Chapter 21	Soft	CAN controller	Reception via software polling	Check the MBON bit at the start and end of the polling routine to see if the message buffer and receive history register can be accessed, because a CAN sleep mode transition request which has been held pending may be under execution. If the MBON bit is cleared (0), stop the processing under execution. Re-execute the processing after the MBON bit is set (1) again.	p. 1240 <input type="checkbox"/>
				If the ROVF bit has been once set (1), the receive history list contradicts. Therefore, scan all the receive message buffers that have completed reception.	p. 1240 <input type="checkbox"/>
		Setting CAN sleep mode/stop mode	To abort transmission before making a request for the CAN sleep mode, perform processing according to Figures 21-46 to 21-48.	p. 1241 <input type="checkbox"/>	
		Bus-off recovery	If a request to change the mode from the initialization mode to any operation mode is made to execute the bus-off recovery sequence again during a bus-off recovery sequence, the receive error counter (CnERC.REC0 to REC6 bits) is cleared. It is therefore necessary to detect 11 contiguous recessive bits 128 times on the bus again.	pp. 1243, 1244 <input type="checkbox"/>	
		Forced shutdown process	If access to another register is executed by software (interrupts including NMI) or DMA immediately after the EFSD bit has been set to 1 and before the GOM bit is cleared to 0, setting the EFSD bit is invalid and the GOM bit is not cleared.	p. 1246 <input type="checkbox"/>	
		Setting CPU standby (from CAN sleep mode)	Check if the CPU is in the CAN sleep mode before setting it to the standby mode. The CAN sleep mode may be released by wakeup after it is checked if the CPU is in the CAN sleep mode and before the CPU is set in the standby mode.	p. 1248 <input type="checkbox"/>	
		Setting CPU standby (from CAN stop mode)	The CAN stop mode can only be released by writing 01 to the CnCTRL.PSMODE1 and CnCTRL.PSMODE0 bits. The CAN stop mode cannot be released by changing the CAN bus.	p. 1249 <input type="checkbox"/>	
Chapter 22	Soft	DMA function (DMA controller)	DSA0 to DSA3 registers	When the value of the DSAn register is read, two 16-bit registers, DSAnH and DSAnL, are read. If reading and updating conflict, the value being updated may be read (see 22.13 Cautions).	p. 1252 <input type="checkbox"/>
				Following reset, set the DSAnH, DSAnL, DDAnH, DDAnL, and DBCn registers before starting DMA transfer. If these registers are not set, the operation when DMA transfer is started is not guaranteed.	p. 1252 <input type="checkbox"/>
		DDA0 to DDA3 registers	When the value of the DDAn register is read, two 16-bit registers, DDAnH and DDAnL, are read. If reading and updating conflict, a value being updated may be read (see 22.13 Cautions).	p. 1253 <input type="checkbox"/>	
			Following reset, set the DSAnH, DSAnL, DDAnH, DDAnL, and DBCn registers before starting DMA transfer. If these registers are not set, the operation when DMA transfer is started is not guaranteed.	p. 1253 <input type="checkbox"/>	
		DBC0 to DBC3 registers	Following reset, set the DSAnH, DSAnL, DDAnH, DDAnL, and DBCn registers before starting DMA transfer. If these registers are not set, the operation when DMA transfer is started is not guaranteed.	p. 1254 <input type="checkbox"/>	
		DADC0 to DADC3 registers	The DS0 bit specifies the size of the transfer data, and does not control bus sizing. If 8-bit data (DS0 bit = 0) is set, therefore, the lower data bus is not always used.	p. 1255 <input type="checkbox"/>	
If the transfer data size is set to 16 bits (DS0 bit = 1), transfer cannot be started from an odd address. Transfer is always started from an address with the first bit of the lower address aligned to 0.	p. 1255 <input type="checkbox"/>				

Chapter	Classification	Function	Details of Function	Cautions	Page
Chapter 22	Soft	DMA function (DMA controller)	DADC0 to DADC3 registers	If DMA transfer is executed on an on-chip peripheral I/O register (as the transfer source or destination), be sure to specify the same transfer size as the register size. For example, to execute DMA transfer on an 8-bit register, be sure to specify 8-bit transfer.	p. 1255 <input type="checkbox"/>
				When DMA transfer is completed (when a terminal count is generated), the Enn bit is cleared to 0 and then the TCn bit is set to 1. If the DCHCn register is read while its bits are being updated, a value indicating "transfer not completed and transfer is disabled" (TCn bit = 0 and Enn bit = 0) may be read.	p. 1256 <input type="checkbox"/>
			DTFR0 to DTFR3 registers	Be sure to follow the steps 22.3 (6) Cautions 2 when changing the DTFRn register settings.	p. 1258 <input type="checkbox"/>
				An interrupt request that is generated in the standby mode (IDEL1, IDLE2, STOP, or sub-IDLE mode) does not start the DMA transfer cycle (nor is the DFn bit set to 1).	p. 1258 <input type="checkbox"/>
				If a DMA start factor is selected by the IFCn5 to IFCn0 bits, the DFn bit is set to 1 when an interrupt occurs from the selected on-chip peripheral I/O, regardless of whether the DMA transfer is enabled or disabled. If DMA is enabled in this status, DMA transfer is immediately started.	p. 1258 <input type="checkbox"/>
				In the V850E/SK3-H, when using UARTA1 and I <sup>2</sup> C02 at the same time, and using the INTUA1R signal as the DMA transfer start factor, set the DTFROB1 bit of option byte 0000007AH (refer to CHAPTER 33 OPTION BYTE FUNCTION) to 1. In this case, the INTIC2 signal cannot be used as the DMA transfer start factor.	p. 1258 <input type="checkbox"/>
				In the V850E/SK3-H, when using UARTA2 and I <sup>2</sup> C00 at the same time, and using the INTUA2R signal as the DMA transfer start factor, set the DTFROB1 bit of option byte 0000007AH (refer to CHAPTER 33 OPTION BYTE FUNCTION) to 1. In this case, the INTIC0 signal cannot be used as the DMA transfer start factor.	p. 1258 <input type="checkbox"/>
			Transfer targets	The operation is not guaranteed for combinations of transfer destination and source marked with "x" in Table 22-2.	p. 1261 <input type="checkbox"/>
			DMA channel priorities	If two or more DMA channels are started with the same factor, a DMA channel with a lower priority may be acknowledged earlier than a DMA channel with a higher priority.	p. 1263 <input type="checkbox"/>
			DMA transfer start factors	Two start factors (software trigger and hardware trigger) cannot be used for one DMA channel. If two start factors are simultaneously generated for one DMA channel, only one of them is valid. The start factor that is valid cannot be identified.	p. 1264 <input type="checkbox"/>
				A new transfer request that is generated after the preceding DMA transfer request was generated or in the preceding DMA transfer cycle is ignored (cleared).	p. 1264 <input type="checkbox"/>
				Therefore, the transfer request intervals for the same DMA channel must be sufficiently separated by the system. When the software trigger is used, completion of the DMA transfer cycle that was generated before can be checked by updating the DBCn register.	p. 1264 <input type="checkbox"/>
			Caution for VSWC register	When using the DMAC, be sure to set an appropriate value, in accordance with the operating frequency, to the VSWC register. When the default value (77H) of the VSWC register is used, or if an inappropriate value is set to the VSWC register, the operation is not correctly performed (for details of the VSWC register, see 3.4.9 (1) (a) System wait control register (VSWC)).	p. 1270 <input type="checkbox"/>

Chapter	Classification	Function	Details of Function	Cautions	Page
Chapter 22	Soft	DMA function (DMA controller)	Caution for DMA transfer executed on internal RAM	When executing the following instructions located in the internal RAM, do not execute a DMA transfer that transfers data to/from the internal RAM (transfer source/destination), because the CPU may not operate correctly afterward. <ul style="list-style-type: none"> <li>• Bit manipulation instruction located in internal RAM (SET1, CLR1, or NOT1)</li> <li>• Data access instruction to misaligned address located in internal RAM</li> </ul> Conversely, when executing a DMA transfer to transfer data to/from the internal RAM (transfer source/destination), do not execute the above two instructions.	p. 1270 <input type="checkbox"/>
			Caution for reading DCHCn.TCn bit (n = 0 to 3)	When performing a DMA transfer from the internal RAM, if the TCn bit is read by the interrupt servicing routine, either of the following conditions must be satisfied. <ul style="list-style-type: none"> <li>• When the TCn bit is read at the start of the interrupt servicing routine, perform the read operation twice consecutively.</li> <li>• Execute at least one instruction at the start of the interrupt servicing routine to access (read/write) the internal RAM, on-chip peripheral I/O register area, programmable peripheral I/O register area, or external memory area before reading the TCn bit.</li> </ul>	p. 1270 <input type="checkbox"/>
			Procedure of stopping DMA transfer (clearing Enn bit)	Forcibly clearing the Enn bit to 0 during DMA transfer can stop the DMA transfer under execution. To stop the DMA transfer, however, be sure to execute either of the (a) or (b) described in 22.13 (4) two procedures. If the Enn bit is cleared to 0 by using a different procedure, the operation is not guaranteed.	p. 1271 <input type="checkbox"/>
			Memory boundary	The operation is not guaranteed if the address of the transfer source or destination exceeds the area of the DMA target (external memory, internal RAM, on-chip peripheral I/O, or expanded internal RAM) during DMA transfer.	p. 1271 <input type="checkbox"/>
			Transferring misaligned data	DMA transfer of misaligned data with a 16-bit bus width is not supported. If an odd address is specified as the transfer source or destination, the least significant bit of the address is forcibly assumed to be 0.	p. 1271 <input type="checkbox"/>
			Registers/bits that must not be rewritten during DMA operation	Set the following registers at the following timing when a DMA operation is not under execution. [Registers] <ul style="list-style-type: none"> <li>• DSAnH, DSAnL, DDAnH, DDAnL, DBCn, and DADCn registers</li> <li>• DTFRn.IFCn5 to DTFRn.IFCn0 bits</li> </ul> [Timing of setting] <ul style="list-style-type: none"> <li>• Period from after reset to start of the first DMA transfer</li> <li>• Time after channel initialization to start of DMA transfer</li> <li>• Period from after completion of DMA transfer (TCn bit = 1) to start of the next DMA transfer</li> </ul>	p. 1272 <input type="checkbox"/>
			Be sure to set the following register bits to 0.	Be sure to set the following register bits to 0. <ul style="list-style-type: none"> <li>• Bits 14 to 10 of DSAnH register</li> <li>• Bits 14 to 10 of DDAnH register</li> <li>• Bits 15, 13 to 8, and 3 to 0 of DADCn register</li> <li>• Bits 6 to 3 of DCHCn register</li> </ul>	p. 1272 <input type="checkbox"/>
			DMA start factor	Care must be exercised when setting the same start trigger for multiple DMA channels. If DMA transfers via such DMA channels are activated, the DMA channel with a lower priority may be acknowledged prior to the DMA channel with a higher priority.	p. 1272 <input type="checkbox"/>
			Read values of DSAn and DDAn registers	Values in the middle of updating may be read from the DSAn and DDAn registers during DMA transfer (n = 0 to 3).	p. 1272 <input type="checkbox"/>

Chapter	Classification	Function	Details of Function	Cautions	Page
Chapter 23	Soft	CRC function	CRCD register	Accessing the CRCD register is prohibited in the following statuses. For details, refer to 3.4.9 (2) Accessing specific on-chip peripheral I/O registers. <ul style="list-style-type: none"> <li>• When the CPU operates with the subclock and the main clock oscillation is stopped</li> <li>• When the CPU operates with the internal oscillation clock</li> </ul>	p. 1274 <input type="checkbox"/>
Chapter 24	Soft	Interrupt/exception processing function	Non-maskable interrupts	For the non-maskable interrupt servicing executed by the non-maskable interrupt request signal (INTWDT2), see 24.2.2 (2) INTWDT2 signal.	p. 1284 <input type="checkbox"/>
				When the EP and NP bits are changed by the LDSR instruction during non-maskable interrupt servicing, in order to restore the PC and PSW correctly during recovery by the RETI instruction, it is necessary to set the EP bit back to 0 and the NP bit back to 1 using the LDSR instruction immediately before the RETI instruction.	p. 1287 <input type="checkbox"/>
			Maskable interrupts	When the EP and NP bits are changed by the LDSR instruction during maskable interrupt servicing, in order to restore the PC and PSW correctly during recovery by the RETI instruction, it is necessary to set the EP bit back to 0 and the NP bit back to 0 using the LDSR instruction immediately before the RETI instruction.	p. 1291 <input type="checkbox"/>
			Maskable interrupts	To perform multiple interrupt servicing, the values of the EIPC and EIPSW registers must be saved before executing the EI instruction. When returning from multiple interrupt servicing, restore the values of EIPC and EIPSW after executing the DI instruction.	pp. 1293 to 1295 <input type="checkbox"/>
			xxICn register	Disable interrupts (DI) or mask the interrupt to read the xxICn.xxIFn bit. If the xxIFn bit is read while interrupts are enabled (EI) or while the interrupt is unmasked, the correct value may not be read when acknowledging an interrupt and reading the bit conflict.	p. 1296 <input type="checkbox"/>
				When manipulating the xxICn.xxMKn bit with the state where an interrupt request can be generated (including an interrupt disable (DI) state), be sure to manipulate with a bit manipulation instruction or by using the IMRm.xxMKn and IMR7L.xxMKn bits (m = 0 to 6).	pp. 1296, 1325 <input type="checkbox"/>
				Be sure to set bits 3 to 5 to "0".	p. 1296 <input type="checkbox"/>
			IMR0 to IMR6, IMR7L registers	Set bits 13 to 15 of the IMR4 register and bits 3 and 4 of the IMR7L register to 1, and set bits 5 to 7 of the IMR7L register to 0. If the setting of these bits is changed, the operation is not guaranteed.	p. 1302 <input type="checkbox"/>
			ISPR register	If an interrupt is acknowledged while the ISPR register is being read in the interrupt enabled (EI) status, the value of the ISPR register after the bits of the register have been set by acknowledging the interrupt may be read. To accurately read the value of the ISPR register before an interrupt is acknowledged, read the register while interrupts are disabled (DI).	pp. 1303, 1325 <input type="checkbox"/>
			Software exception	When the EP and NP bits are changed by the LDSR instruction during the software exception processing, in order to restore the PC and PSW correctly during recovery by the RETI instruction, it is necessary to set the EP bit back to 1 and the NP bit back to 0 using the LDSR instruction immediately before the RETI instruction.	p. 1306 <input type="checkbox"/>
Exception trap	Since it is possible to assign this instruction to an illegal opcode in the future, it is recommended that it not be used.	p. 1308 <input type="checkbox"/>			
	DBPC and DBPSW can be accessed after the illegal opcode is executed and before the DBRET instruction is executed.	p. 1309 <input type="checkbox"/>			
Debug trap	DBPC and DBPSW can be accessed after the DBTRAP instruction is executed and before the DBRET instruction is executed.	p. 1311 <input type="checkbox"/>			



Chapter	Classification	Function	Details of Function	Cautions	Page
Chapter 24	Soft	Interrupt/exception processing function	External interrupt request input pins (NMI and INTP0 to INTP9)	The same external interrupt request input pins are assigned to two ports. Therefore, the setting of each valid edge is set independently in the register corresponding to each port. Be sure to use the external interrupt request input pin in either of the two ports. Set the valid edge detection of the external interrupt request input pin of the port not being used to "No edge detected".	p. 1312 <input type="checkbox"/>
			INTF0, INTR0 registers	When the function is changed from the external interrupt function (alternate function) to the port function, an edge may be detected. Therefore, clear the INTF0n and INTR0n bits to 00, and then set the port mode. Be sure to clear the INTF0n and INTR0n bits to 00 when these registers are not used as the NMI or INTP0 to INTP3 pins.	p. 1314 <input type="checkbox"/> p. 1314 <input type="checkbox"/>
			INTF3, INTR3 registers	When the function is changed from the external interrupt function (alternate function) to the port function, an edge may be detected. Therefore, clear the INTF31 and INTR31 bits to 00, and then set the port mode.	p. 1315 <input type="checkbox"/>
			INTF3, INTR3 registers	The INTP7 pin and RXDA0 pin are alternate-function pins. When using the pin as the RXDA0 pin, disable edge detection for the INTP7 alternate-function pin (clear the INTF3.INTF31 bit and the INTR3.INTR31 bit to 0). When using the pin as the INTP7 pin, stop UAR0 reception (clear the UA0CTL0.UA0RXE bit to 0). Be sure to clear the INTF31 and INTR31 bits to 00 when these registers are not used as INTP7 pin.	p. 1315 <input type="checkbox"/> p. 1315 <input type="checkbox"/>
			INTF4, INTR4 registers	When the function is changed from the external interrupt function (alternate function) to the port function, an edge may be detected. Therefore, clear the INTF42 and INTR42 bits to 00, and then set the port mode. Be sure to clear the INTF42 and INTR42 bits to 00 when these registers are not used as INTP2 pin.	p. 1316 <input type="checkbox"/> p. 1316 <input type="checkbox"/>
			INTF5, INTR5 registers	When the function is changed from the external interrupt function (alternate function) to the port function, an edge may be detected. Therefore, clear the INTF51 and INTR51 bits to 00, and then set the port mode. Be sure to clear the INTF51 and INTR51 bits to 00 when these registers are not used as INTP7 pin.	p. 1317 <input type="checkbox"/> p. 1317 <input type="checkbox"/>
			INTF6, INTR6 registers	When the function is changed from the external interrupt function (alternate function) to the port function, an edge may be detected. Therefore, clear the INTF66 and INTR66 bits to 00, and then set the port mode. Be sure to clear the INTF66 and INTR66 bits to 00 when these registers are not used as INTP9 pin.	p. 1318 <input type="checkbox"/> p. 1318 <input type="checkbox"/>
			INTF8, INTR8 registers	When the function is changed from the external interrupt function (alternate function) to the port function, an edge may be detected. Therefore, clear the INTF80 and INTR80 bits to 00, and then set the port mode. The INTP8 pin and RXDA3 pin are alternate-function pins. When using the pin as the RXDA3 pin, disable edge detection for the INTP8 alternate-function pin (clear the INTF8.INTF80 bit and the INTR8.INTR80 bit to 0). When using the pin as the INTP8 pin, stop UAR03 reception (clear the UA3CTL0.UA3RXE bit to 0). Be sure to set bits 1 to 7 of the INTF8 and INTR8 registers to 0. Be sure to clear the INTF80 and INTR80 bits to 00 when these registers are not used as INTP8 pin.	p. 1319 <input type="checkbox"/> p. 1319 <input type="checkbox"/> p. 1319 <input type="checkbox"/> p. 1319 <input type="checkbox"/>
			INTF9, INTR9 registers	When the function is changed from the external interrupt function (alternate function) to the port function, an edge may be detected. Therefore, clear the INTF9n and INTR9n bits to 0, and then set the port mode.	p. 1320 <input type="checkbox"/>

Chapter	Classification	Function	Details of Function	Cautions	Page
Chapter 24	Soft	Interrupt/exception processing function	INTF9, INTR9 registers	Be sure to clear the INTF9n and INTR9n bits to 00 when these registers are not used as any of pins INTP4 to INTP6, and INTP8.	p. 1320 <input type="checkbox"/>
			INTF15, INTR15 registers	When the function is changed from the external interrupt function (alternate function) to the port function, an edge may be detected. Therefore, clear the INTF15n and INTR15n bits to 00, and then set the port mode.	p. 1321 <input type="checkbox"/>
		Be sure to set bits 0, 1, and 4 to 7 of the INTF15 and INTR15 registers to 0.		p. 1321 <input type="checkbox"/>	
		Be sure to clear the INTF15n and INTR15n bits to 00 when these registers are not used as INTP6 or INTP9 pin.		p. 1321 <input type="checkbox"/>	
		NFC register	Be careful about the following points when using the interrupt and DMA functions.	p. 1322 <input type="checkbox"/>	
			<ul style="list-style-type: none"> <li>When using the interrupt function, after the 3 sampling clocks have elapsed, enable interrupts after the interrupt request flag (PIC3.PIF3 bit) has been cleared.</li> <li>When using the DMA function (started by INTP3), enable DMA after 3 sampling clocks have elapsed.</li> </ul> Be sure to set bits 3 to 6 to "0".	p. 1322 <input type="checkbox"/>	
		NMI pin	The NMI pin alternately functions as the P02 pin. It functions as the P02 pin after reset. To enable the NMI pin, validate the NMI pin with the PMC0 register. The initial setting of the NMI pin is "No edge detected". Select the NMI pin valid edge using the INTF0 and INTR0 registers.	p. 1325 <input type="checkbox"/>	
Switching DMA transfer start factors	Because the INTP8 signal and the INTTM2EQ0 signal of the DMA transfer start factors are used alternately, they cannot be used at the same time. When the INTP8 signal is used as a DMA transfer start factor, set the DTFROB0 bit in option byte 0000007AH to 0 (refer to CHAPTER 33 OPTION BYTE FUNCTION). In this case, the INTTM2EQ0 signal cannot be used as the DMA transfer start factors. For details, see Table 22-1 DMA Transfer Start Factors.	p. 1325 <input type="checkbox"/>			
Chapter 25	Soft	Key interrupt function	KRM register	Rewrite the KRM register after once clearing the KRM register to 00H.	p. 1327 <input type="checkbox"/>
			KR0 to KR7 pin	If a low level is input to any of the KR0 to KR7 pins, the INTKR signal is not generated even if the falling edge of another pin is input.	p. 1327 <input type="checkbox"/>
	KR7 pin RXDA1 pin			The KR7 and RXDA1 pins must not be used at the same time. In the V850E/SK3-H, the KR7 and RXDA1 pins are assigned to two ports each, and cannot be used at the same time at different ports. To use the KR7 pin, set the UA1CTL0.UA1RXE bit to 0 (it is recommended to set the PFC91 bit to 1 and PFCE91 bit to 0 when using the KR7 pin at P91). To use the RXDA1 pin, set the KRM.KRM7 bit of the KR7 pin to 0.	p. 1327 <input type="checkbox"/>
	KRn pin TIQ0m pin			The KRn and TIQ0m pins must not be used at the same time (n = 0 to 3, m = 0 to 3). The KR2 and TIQ03 pins and the KR3 and TIQ00 pins are assigned to two ports each, and cannot be used at the same time at different ports. Settings for using the KRn or TIQ0m pin are shown in 25.3 (3).	p. 1328 <input type="checkbox"/>
	Soft		KRM register	If the KRM register is changed, an interrupt request signal (INTKR) may be generated. To prevent this, change the KRM register after disabling interrupts (DI) or masking, then clear the interrupt request flag (KRIC.KRIF bit) to 0, and enable interrupts (EI) or clear the mask.	p. 1328 <input type="checkbox"/>
			Switching between port mode and alternate-function mode	To use the key interrupt function, be sure to set the port pin to the key return pin and then enable the operation with the KRM register. To switch from the key return pin to the port pin, disable the operation with the KRM register and then set the port pin.	p. 1328 <input type="checkbox"/>

Chapter	Classification	Function	Details of Function	Cautions	Page
Chapter 25	Soft	Key interrupt function	Switching DMA transfer start factor	The INTKR signal and the INTTM1EQ0 signal, both being the DMA transfer start factors, are alternate functions of the same pin, and they cannot be used at the same time. To use the INTKR signal as the DMA transfer start factor, set the DTFROB0 bit in the option byte area 0000007AH to 0 (refer to CHAPTER 33 OPTION BYTE FUNCTION). In this case, the INTTM1EQ0 signal cannot be used as the DMA transfer start factor. For details, see Table 22-1 DMA Transfer Start Factors.	p. 1328 □
Chapter 26	Soft	Standby function	PSC register	Before setting the IDLE1, IDLE2, STOP, or sub-IDLE mode, set the PSMR.PSM1 and PSMR.PSM0 bits and then set the STP bit.	p. 1330 □
				If there is an unmasked interrupt request signal being held pending when the IDLE1/IDLE2/STOP mode is set, set the bit corresponding to the interrupt request signal (NMI1M, NMI0M, or INTM) to 1, and then set the STP bit to 1.	p. 1330 □
				Be sure to set bits 0, 2, 3, and 7 to "0".	p. 1330 □
			PSMR register	Be sure to clear bits 2 to 7 to "0".	p. 1331 □
				The PSM0 and PSM1 bits are valid only when the PSC.STP bit is 1.	p. 1331 □
			OSTS register	Be sure to clear bits 3 to 7 to "0".	p. 1332 □
				The oscillation stabilization time following reset release is $2^{16}/f_x$ (because the initial value of the OSTS register = 06H).	p. 1332 □
				In clock mode 1, if the system shifts to IDLE2 mode while the PLL is operating, be sure to set a setup time of at least 800 $\mu s$ to be inserted after IDLE2 mode is released. If the PLL is stopped, set a setup time of at least 350 $\mu s$ to be inserted after IDLE2 mode is released.	p. 1333 □
				In clock mode 1, if the system shifts to STOP mode while the PLL is operating, be sure to set an oscillation stabilization time of at least 1 ms to be inserted after STOP mode is released.	p. 1333 □
				In clock modes 2, 3, and 4, if the system shifts to IDLE2 mode while the SSCG is operating, be sure to set a setup time of at least 1 ms to be inserted after IDLE2 mode is released. If the SSCG is stopped, set a setup time of at least 800 $\mu s$ to be inserted after IDLE2 mode is released.	p. 1333 □
				In clock modes 2, 3, and 4, if the system shifts to STOP mode while the SSCG is operating, be sure to set an oscillation stabilization time of at least 2 ms to be inserted after STOP mode is released.	p. 1333 □
			HALT mode	Insert five or more NOP instructions after the HALT instruction.	p. 1334 □
				If the HALT instruction is executed while an unmasked interrupt request signal is being held pending, the status shifts to HALT mode, but the HALT mode is then released immediately by the pending interrupt request.	p. 1334 □
			IDLE1 mode	Insert five or more NOP instructions after the instruction that stores data in the PSC register to set the IDLE1 mode.	p. 1336 □
				If the IDLE1 mode is set while an unmasked interrupt request signal is being held pending, the IDLE1 mode is released immediately by the pending interrupt request.	p. 1336 □
			IDLE2 mode	Insert five or more NOP instructions after the instruction that stores data in the PSC register to set the IDLE2 mode.	p. 1339 □
If the IDLE2 mode is set while an unmasked interrupt request signal is being held pending, the IDLE2 mode is released immediately by the pending interrupt request.	p. 1339 □				
Securing setup time when releasing IDLE2 mode	In clock mode 1, if the system shifts to IDLE2 mode while the PLL is operating, be sure to set a setup time of at least 800 $\mu s$ to be inserted after IDLE2 mode is released. If the PLL is stopped, set a setup time of at least 350 $\mu s$ to be inserted after IDLE2 mode is released.	p. 1342 □			

Chapter	Classification	Function	Details of Function	Caution	Page
Chapter 26	Soft	Standby function	Securing setup time when releasing IDLE2 mode	In clock modes 2, 3, and 4, if the system shifts to IDLE2 mode while the SSCG is operating, be sure to set a setup time of at least 1 ms to be inserted after IDLE2 mode is released. If the SSCG is stopped, set a setup time of at least 800 $\mu$ s to be inserted after IDLE2 mode is released.	p. 1342 <input type="checkbox"/>
			STOP mode	Insert five or more NOP instructions after the instruction that stores data in the PSC register to set the STOP mode.	p. 1343 <input type="checkbox"/>
				If the STOP mode is set while an unmasked interrupt request signal is being held pending, the STOP mode is released immediately by the pending interrupt request.	p. 1343 <input type="checkbox"/>
			Securing oscillation stabilization time when releasing STOP mode	In clock mode 1, if the system shifts to STOP mode while the PLL is operating, be sure to set an oscillation stabilization time of at least 1 ms to be inserted after STOP mode is released.	p. 1346 <input type="checkbox"/>
				In clock modes 2, 3, and 4, if the system shifts to STOP mode while the SSCG is operating, be sure to set an oscillation stabilization time of at least 2 ms to be inserted after STOP mode is released.	p. 1346 <input type="checkbox"/>
			Subclock operation mode	Secure the oscillation stabilization time of the subclock oscillator before shifting to subclock operation mode. The subclock oscillator starts oscillation after power is applied.	p. 1347 <input type="checkbox"/>
				Before setting subclock operation mode, be sure to stop operation of the SSCG (SSCGCTL.SSCGON bit = 0). Note that the SSCG cannot be used in clock mode 1.	p. 1347 <input type="checkbox"/>
				When manipulating the CK3 bit, do not change the set values of the PCC.CK2 to PCC.CK0 bits (using a bit manipulation instruction to manipulate the bit is recommended). For details of the PCC register, see 6.3 (1) Processor clock control register (PCC).	p. 1347 <input type="checkbox"/>
				If the following conditions are not satisfied, change the CK2 to CK0 bits so that the conditions are satisfied and set the subclock operation mode. Internal system clock ( $f_{CLK}$ ) > Subclock ( $f_{XT} = 32.768 \text{ kHz}$ ) $\times$ 4	p. 1347 <input type="checkbox"/>
				When stopping operation of the main clock oscillator, be sure to also stop operation of the on-chip peripheral functions operating on the main oscillation clock ( $f_x$ ) and peripheral clock ( $f_{XP}$ ).	p. 1347 <input type="checkbox"/>
				In clock modes 2, 3 and 4, do not clear (0) the PLLCTL.PLLON bit by software (i.e., do not stop the PLL). When the main clock oscillator stops operating (PCC.MCK bit = 1), the PLL automatically stops operating at the same time, with the PLLCTL.PLLON bit still set to 1 (PLL operation enabled). Similarly, when the main clock oscillator is set to operation enabled again (PCC.MCK bit = 0), the PLL also starts operating, and enters a locked state until the oscillation stabilization time secured by software elapses (at least 1 ms).	p. 1347 <input type="checkbox"/>
				When manipulating the CK3 bit, do not change the set values of the CK2 to CK0 bits (using a bit manipulation instruction to manipulate the bit is recommended). For details of the PCC register, see 6.3 (1) Processor clock control register (PCC).	p. 1347 <input type="checkbox"/>
				When the CPU is operating on the subclock and main clock oscillation is stopped, accessing a register in which a wait occurs is disabled. If a wait is generated, it can be released only by reset (see 3.4.9 (2)).	p. 1349 <input type="checkbox"/>
			Sub-IDLE mode	Following the store instruction to the PSC register for setting the sub-IDLE mode, insert the five or more NOP instructions.	p. 1350 <input type="checkbox"/>
				If the sub-IDLE mode is set while an unmasked interrupt request signal is being held pending, the sub-IDLE mode is then released immediately by the pending interrupt request.	p. 1350 <input type="checkbox"/>

Chapter	Classification	Function	Details of Function	Cautions	Page	
Chapter 26	Soft	Standby function	Sub-IDLE mode	When stopping operation of the main clock oscillator, be sure to also stop operation of the on-chip peripheral functions operating on the main oscillation clock (fx) and peripheral clock (fxP).	p. 1350 <input type="checkbox"/>	
				In clock modes 2, 3, and 4, do not clear (0) the PLLCTL.PLLON bit by software (i.e., do not stop the PLL). When the main clock oscillator stops operating (PCC.MCK bit = 1), the PLL automatically stops operating at the same time, with the PLLCTL.PLLON bit still set to 1 (PLL operation enabled). Similarly, when the main clock oscillator is set to operation enabled again (PCC.MCK bit = 0), the PLL also starts operating, and enters a locked state until the oscillation stabilization time secured by software elapses (at least 1 ms).	p. 1350 <input type="checkbox"/>	
				When the sub-IDLE mode is released, 12 cycles of the subclock (about 366 μs) elapse from when the interrupt request signal that releases the sub-IDLE mode is generated to when the mode is released.	p. 1351 <input type="checkbox"/>	
			Status Transition Diagram	In clock modes 2, 3, and 4, do not clear (0) the PLLCTL.PLLON bit by software (i.e., do not stop the PLL).	p. 1357 <input type="checkbox"/>	
Chapter 27	Soft	Reset function	Emergency operation mode	In emergency operation mode, do not access on-chip peripheral I/O registers other than registers used for interrupts, ports, WDT2, or TMM0, each of which can operate on the internal oscillation clock. In addition, CSIB0 to CSIB5, CSIE0 <sup>Note</sup> , CSIE1 <sup>Note</sup> , and UARTA0 cannot operate on an externally input clock in this mode. Note Other than μPD70F3931 (V850E/SJ3-H), 70F3932 (V850E/SJ3-H), and 70F3933 (V850E/SJ3-H)	p. 1358 <input type="checkbox"/>	
				LVI circuit internal reset	An LVI circuit internal reset does not reset the LVI circuit.	p. 1359 <input type="checkbox"/>
				RESF register	Be sure to set bits 2, 3, and 5 to 7 to "0".	p. 1360 <input type="checkbox"/>
			Reset operation via RESET pin	The OCDM register is initialized by the RESET pin input. Therefore, note with caution that, if a high level is input to the P05/DRST pin after a reset release before the OCDM.OCDM0 bit is cleared, the V850E/SJ3-H or V850E/SK3-H may enter on-chip debug mode. For details, refer to CHAPTER 4 PORT FUNCTIONS.	p. 1361 <input type="checkbox"/>	
Chapter 28	Soft	Clock monitor	CLM register LVIM register	Once the CLME bit has been set to 1, it cannot be cleared to 0 by any means other than reset.	p. 1371 <input type="checkbox"/>	
				Be sure to set bits 1 to 7 to "0".	p. 1371 <input type="checkbox"/>	
Chapter 29	Soft	Low-voltage detector	LVIM register	When the LVION and LVIMD bits to 1, the low-voltage detector cannot be stopped until the reset request due to other than the low-voltage detection is generated.	p. 1376 <input type="checkbox"/>	
				When the LVION bit is set to 1, the comparator in the LVI circuit starts operating. Wait 0.2 ms or longer by software before checking the voltage at the LVIF bit after the LVION bit is set.	p. 1376 <input type="checkbox"/>	
				Be sure to clear bits 6 to 2 to "0".	p. 1376 <input type="checkbox"/>	
			LVIS register	This register cannot be written until a reset request due to something other than low-voltage detection is generated after the LVIM.LVION and LVIM.LVIMD bits are set to 1.	p. 1377 <input type="checkbox"/>	
				Be sure to clear bits 7 to 1 to "0".	p. 1377 <input type="checkbox"/>	
			To use for internal reset signal (LVIREs)	If LVIMD bit is set to 1, the contents of the LVIM and LVIS registers cannot be changed until a reset request other than LVI is generated.	p. 1378 <input type="checkbox"/>	
			To use for interrupt (INTLVI)	When the INTLVI signal is generated, confirm, using the LVIM/LVIF bit, whether the INTLVI signal is generated due to a supply voltage drop or rise across the detected voltage.	p. 1379 <input type="checkbox"/>	
PEMU1 register	This bit (EVARAMIN) is not automatically cleared.	p. 1381 <input type="checkbox"/>				

Chapter	Classification	Function	Details of Function	Caution	Page
Chapter 30	Hard	Regulator	Regulator	Use the regulator with a setting of $V_{DD} = EV_{DD} = AV_{REF0} = AV_{REF1} \geq BV_{DD}$ .	p. 1382 □
Chapter 31	Soft	ROM correction function	CORADn register	When setting an address to be corrected in the CORADn register, clear the higher bits to 0 in accordance with the capacity of the internal ROM.	p. 1390 □
			ROM correction function	The ROM correction function cannot be used to correct data in the internal ROM. It can only be used to correct instruction codes. If ROM correction is used to correct data, that data is replaced with a DBTRAP instruction code.	p. 1390 □
			ROM code	ROM correction is not performed in regards to the ROM code before writing in the CORCNn register ends.	p. 1390 □
			DBTRAP instruction	After executing a DBTRAP instruction, the PSW.NP, EP, and DI bits are set to 111, and interrupt/exception cannot be acknowledged. After executing a DBTRAP instruction, change the PSW register value as required.	p. 1390 □
			DBPC, DBPSW registers	The DBPC and DBPSW registers can be accessed while DBTRAP instructions are being executed.	p. 1390 □
			Correction addresses	If the addresses of the instructions executed immediately after the CORCNn register setting (enabled) are set as the correction addresses, normal operation may not be obtained (DBTRAP is not generated).	p. 1390 □
Chapter 32	Hard	Flash memory	CSIB0 + HS, CSIB3 + HS	Be sure to connect the REGC pin to GND via 4.7 $\mu$ F capacitor.	pp. 1400, □ 1401
				Clock cannot be supplied from the CLK pin of the flash memory programmer. Create an oscillator on the board and supply clock.	pp. 1400, □ 1401
				Do not input a high level to the $\overline{DRST}$ pin.	pp. 1403, □ 1405
			FLMD1 pin	If the $V_{DD}$ signal is input to the FLMD1 pin from another device during on-board writing and immediately after reset, isolate this signal.	p. 1410 □
			Serial interface pin	When connecting a dedicated flash memory programmer to a serial interface pin that is connected to another device on-board, care should be taken to avoid conflict of signals and malfunction of the other device.	p. 1411 □
	Soft	Rewriting by self programming	Make sure that constant data of rewriting target is situated in a different block than program code. See 32.2 Memory Configuration for the block configuration.	p. 1414 □	
	Hard	Flash memory	FLMD0 pin when self programming	Make sure that the FLMD0 pin is at 0 V when reset is released.	p. 1419 □
Chapter 33	Soft	Option Byte function	Option Byte (0000007AH)	Be sure to set bits 2, 3, 6 and 7 to "0".	p. 1422 □
			Option Byte (0000007BH)	Be sure to set the PLLI0 bit to 0 (no division) in clock mode 4.	p. 1423 □
				Be sure to set bits 4 to 7 to "0".	p. 1423 □
			An example of the program when using the CA850	Be sure to write 6 bytes of data to the section of the option byte. If fewer than 6 bytes are written, an error will occur at linking. Set addresses 007CH to 007FH to 0x00.	p. 1424 □ p. 1424 □

Chapter	Classification	Function	Details of Function	Cautions	Page	
Chapter 34	Hard, soft	On-chip debug function	On-chip debug mode register (OCDM)	When using the DDI, DDO, DCK, and DMS pins not as on-chip debug pins but as port pins after external reset, any of the following actions must be taken. <ul style="list-style-type: none"> <li>• Input a low level to the P05/INTP2/DRST pin.</li> <li>• Set the OCDM0 bit. In this case, take the following actions.                             <ul style="list-style-type: none"> <li>&lt;1&gt; Clear the OCDM0 bit to 0.</li> <li>&lt;2&gt; Fix the P05/INTP2/DRST pin to the low level until &lt;1&gt; is completed.</li> </ul> </li> </ul>	p. 1430 <input type="checkbox"/>	
				The DRST pin has an on-chip pull-down resistor. This resistor is disconnected when the OCDM0 flag is cleared to 0.	p. 1430 <input type="checkbox"/>	
	Soft			Cautions (Debugging with DCU)	If a reset signal is input (from the target system or a reset signal from an internal reset source) during RUN (program execution), the break function may malfunction.	p. 1432 <input type="checkbox"/>
					Even if the reset signal is masked by the mask function, the I/O buffer (port pin) may be reset if a reset signal is input from a pin.	p. 1432 <input type="checkbox"/>
					Pin reset during a break is masked and the CPU and peripheral I/O are not reset. If pin reset or internal reset is generated as soon as the flash memory is rewritten by DMM or read by the RAM monitor function while the user program is being executed, the CPU and peripheral I/O may not be correctly reset.	p. 1432 <input type="checkbox"/>
					Emulation of ROM correction cannot be executed.	p. 1432 <input type="checkbox"/>
					In the on-chip debug mode, the DDO pin is forcibly set to the high-level output	p. 1432 <input type="checkbox"/>
	Hard			Cautions (Debugging without using DCU)	Initialize the ASID register to 00H during on-chip debugging.	p. 1432 <input type="checkbox"/>
					Do not mount a device that was used for debugging on a mass-produced product, because the flash memory was rewritten during debugging and the number of rewrites of the flash memory cannot be guaranteed. Moreover, do not embed the debug monitor program into mass-produced products.	p. 1443 <input type="checkbox"/>
	Soft				Forced breaks cannot be executed if one of the following conditions is satisfied. <ul style="list-style-type: none"> <li>• Interrupts are disabled (DI)</li> <li>• Interrupts issued for the serial interface, which is used for communication between MINICUBE2 and the target device, are masked</li> <li>• Standby mode is entered while standby release by a maskable interrupt is prohibited</li> <li>• Mode for communication between MINICUBE2 and the target device is UARTA0, and the main clock has been stopped</li> </ul>	p. 1443 <input type="checkbox"/>
					The pseudo RRM function and DMM function do not operate if one of the following conditions is satisfied. <ul style="list-style-type: none"> <li>• Interrupts are disabled (DI)</li> <li>• Interrupts issued for the serial interface, which is used for communication between MINICUBE2 and the target device, are masked</li> <li>• Standby mode is entered while standby release by a maskable interrupt is prohibited</li> <li>• Mode for communication between MINICUBE2 and the target device is UARTA0, and the main clock has been stopped</li> <li>• Mode for communication between MINICUBE2 and the target device is UARTA0, and a clock different from the one specified in the debugger is used for communication</li> </ul>	p. 1443 <input type="checkbox"/>

Chapter	Classification	Function	Details of Function	Cautions	Page	
Chapter 34	Soft	On-chip debug function	Cautions (Debugging without using DCU)	The standby mode is released by the pseudo RRM function and DMM function if one of the following conditions is satisfied. <ul style="list-style-type: none"> <li>• Mode for communication between MINICUBE2 and the target device is CSIB0 or CSIB3</li> <li>• Mode for communication between MINICUBE2 and the target device is UARTA0, and the main clock has been supplied.</li> </ul>	p. 1443 <input type="checkbox"/>	
				Peripheral I/O registers that requires a specific sequence cannot be rewritten with the DMM function.	p. 1443 <input type="checkbox"/>	
				If a space where the debug monitor program is allocated is rewritten by flash self programming, the debugger can no longer operate normally.	p. 1443 <input type="checkbox"/>	
Chapter 35	Hard	Electrical specification	Absolute maximum ratings	Do not directly connect the output (or I/O) pins of IC products to each other, or to V <sub>DD</sub> , V <sub>CC</sub> , and GND. Open-drain pins or open-collector pins, however, can be directly connected to each other. Direct connection of the output pins between an IC product and an external circuit is possible, if the output pins can be set to the high-impedance state and the output timing of the external circuit is designed to avoid output conflict.	p. 1448 <input type="checkbox"/>	
				Product quality may suffer if the absolute maximum rating is exceeded even momentarily for any parameter. That is, the absolute maximum ratings are rated values at which the product is on the verge of suffering physical damage, and therefore the product must be used under conditions that ensure that the absolute maximum ratings are not exceeded. The ratings and conditions indicated for DC characteristics and AC characteristics represent the quality assurance range during normal operation.	p. 1448 <input type="checkbox"/>	
				Main clock oscillator characteristics	When using the main clock oscillator, wire as follows in the area enclosed by the broken lines in the above figure to avoid an adverse effect from wiring capacitance. <ul style="list-style-type: none"> <li>• Keep the wiring length as short as possible.</li> <li>• Do not cross the wiring with the other signal lines.</li> <li>• Do not route the wiring near a signal line through which a high fluctuating current flows.</li> <li>• Always make the ground point of the oscillator capacitor the same potential as V<sub>SS</sub>.</li> <li>• Do not ground the capacitor to a ground pattern through which a high current flows.</li> <li>• Do not fetch signals from the oscillator.</li> </ul>	p. 1450 <input type="checkbox"/>
				When the main clock is stopped and the device is operating on the subclock, wait until the oscillation stabilization time has been secured by the program before switching back to the main clock.	p. 1450 <input type="checkbox"/>	
				For the resonator selection and oscillator constant, customers are requested to either evaluate the oscillation themselves or apply to the resonator manufacturer for evaluation.	p. 1450 <input type="checkbox"/>	
				This oscillator constant is a reference value based on evaluation under a specific environment by the resonator manufacturer. If optimization of oscillator characteristics is necessary in the actual application, apply to the resonator manufacturer for evaluation on the implementation circuit.  The oscillation voltage and oscillation frequency indicate only oscillator characteristics. Use the V850E/SJ3-H and V850E/SK3-H so that the internal operating conditions are within the specifications of the DC and AC characteristics.	pp. 1451, 1452 <input type="checkbox"/>	



Chapter	Classification	Function	Details of Function	Cautions	Page		
Chapter 35	Hard	Electrical specification	Subclock oscillator characteristics	When using the subclock oscillator, wire as follows in the area enclosed by the broken lines in the above figures to avoid an adverse effect from wiring capacitance.	p. 1453 <input type="checkbox"/>		
				<ul style="list-style-type: none"> <li>• Keep the wiring length as short as possible.</li> <li>• Do not cross the wiring with the other signal lines.</li> <li>• Do not route the wiring near a signal line through which a high fluctuating current flows.</li> <li>• Always make the ground point of the oscillator capacitor the same potential as V<sub>SS</sub>.</li> <li>• Do not ground the capacitor to a ground pattern through which a high current flows.</li> <li>• Do not fetch signals from the oscillator.</li> </ul>			
				The subclock oscillator is designed as a low-amplitude circuit for reducing power consumption, and is more prone to malfunction due to noise than the main clock oscillator. Particular care is therefore required with the wiring method when the subclock is used.		p. 1453 <input type="checkbox"/>	
				For the resonator selection and oscillator constant, customers are requested to either evaluate the oscillation themselves or apply to the resonator manufacturer for evaluation.		p. 1453 <input type="checkbox"/>	
				Data retention characteristics		Shifting to STOP mode and restoring from STOP mode must be performed within the rated operating range.	p. 1459 <input type="checkbox"/>
				AC characteristics		If the load capacitance exceeds 50 pF due to the circuit configuration, bring the load capacitance of the device to 50 pF or less by inserting a buffer or by some other means.	p. 1460 <input type="checkbox"/>
				In multiplexed bus mode		When operating at f <sub>CPU</sub> > 20 MHz, be sure to insert address hold waits and address setup waits.	p. 1462 <input type="checkbox"/>
						When operating at f <sub>CPU</sub> > 32 MHz, be sure to insert at least one data wait.	p. 1462 <input type="checkbox"/>
				In separate bus mode		When operating at f <sub>CPU</sub> > 20 MHz, be sure to insert address hold waits and address setup waits.	p. 1467 <input type="checkbox"/>
						When operating at f <sub>CPU</sub> > 20 MHz, be sure to insert at least one data wait.	p. 1467 <input type="checkbox"/>
A/D converter	Do not set (read/write) alternate-function ports during A/D conversion; otherwise the conversion resolution may be degraded.	p. 1483 <input type="checkbox"/>					
Appendix A	Soft	Development tool	Embedded Software	To purchase the RX850 or RX850 Pro, first fill in the purchase application form and sign the user agreement.	p. 1505 <input type="checkbox"/>		

## APPENDIX E REVISION HISTORY

### E.1 Major Revisions in This Edition

(1/4)

Page	Description
Throughout	<ul style="list-style-type: none"> <li>• Addition of the following products  <math>\mu</math>PD70F3931GJA-GAE-G, 70F3932GJA-GAE-G, 70F3933GJA-GAE-G, 70F3934GJA-GAE-G,  70F3935GJA-GAE-G, 70F3936GJA-GAE-G, 70F3937GJA-GAE-G, 70F3938GJA-GAE-G, 70F3939GJA-GAE-G</li> <li>• Change of the <b>Remark</b> about n and m values in <b>CHAPTER 19 I<sup>2</sup>C BUS</b>  n = 0 to 5, m = 0, 1, 3  ↓  Only <math>\mu</math>PD70F3931 (V850E/SJ3-H), 70F3932 (V850E/SJ3-H), 70F3933 (V850E/SJ3-H): n = 0 to 3, m = 0, 1  Other than <math>\mu</math>PD70F3931 (V850E/SJ3-H), 70F3932 (V850E/SJ3-H), 70F3933 (V850E/SJ3-H): n = 0 to 5, m = 0, 1, 3</li> </ul>
pp.23, 24	Addition of description to <b>Table 1-1 V850E/SJ3-H and V850E/SK3-H Products</b>
pp.25 to 27	Modification of description in <b>1.2 Features</b>
p.28	Addition of description to <b>1.4.1 V850E/SJ3-H</b>
pp.29, 30	Addition of description to <b>1.5.1 V850E/SJ3-H</b>
p.35	Addition of description to <b>1.6.1 (1) V850E/SJ3-H</b>
p.39	Addition of description to <b>1.6.2 (3) ROM</b>
p.39	Modification of description in <b>1.6.2 (7) Clock generator (CG)</b>
p.40	Addition of description to <b>1.6.2 (13) Serial interface</b>
p.42	Addition of description to <b>1.6.2 (24) Ports</b>
pp.44, 45	Addition of description to <b>2.1 (1) Port pins</b>
pp.53 to 59	Addition of description to <b>2.1 (2) Non-port pins</b>
pp.66, 67	Addition of description to <b>2.4 Pin I/O Circuit Types, I/O Buffer Power Supplies and Connection of Unused Pins</b>
p.85	Addition of description to <b>Figure 3-1 Image on Address Space</b>
p.88	Addition of <b>Figure 3-2 (b) When not using expanded internal RAM</b>
p.90	Addition of <b>Figure 3-3 (b) When not using expanded internal RAM</b>
p.91	Addition of <b>3.4.4 (1) (a) Internal ROM (512 KB)</b>
p.92	Addition of <b>3.4.4 (1) (b) Internal ROM (768 KB)</b>
p.92	Addition of description to <b>3.4.4 (1) (c) Internal ROM (1024 KB)</b>
p.96	Addition of description to <b>3.4.4 (5) External memory area</b>
p.96	Addition of description to <b>3.4.4 (6) Expanded internal RAM area</b>
p.96	Addition of description to <b>3.4.4 (6) (a) Expanded internal RAM (16 KB)</b>
p.99	Addition of description to <b>3.4.4 (7) Product selection register (PRDSEL)</b>
p. 100	Addition of description to <b>Table 3-3 Product Name Setting Examples</b>
p.103	Addition of <b>Figure 3-14 (b) Not using expanded internal RAM</b>
pp.104, 107, 108, 110, 115 to 117, 122	Addition of description to <b>3.4.6 Peripheral I/O registers</b>
p.130	Addition of description to <b>3.4.9 (2) Accessing specific on-chip peripheral I/O registers</b>
p.136	Addition of description to <b>Table 4-3 Port Configuration (V850E/SJ3-H)</b>

Page	Description
p.141	Addition of description to <b>Table 4-6 Port 0 Alternate-Function Pins</b>
p.142	Addition of description to <b>4.3.1 (3) Port 0 mode control register (PMC0)</b>
p.143	Addition of description to <b>4.3.1 (5) Port 0 function control expansion register (PFCE0) (Not included in the <math>\mu</math>PD70F3931 (V850E/SJ3-H), 70F3932 (V850E/SJ3-H), and 70F3933 (V850E/SJ3-H).)</b>
p.143	Addition of description to <b>4.3.1 (6) Port 0 alternate function specifications</b>
p.167	Addition of description to <b>Table 4-12 Port 6 Alternate-Function Pins</b>
pp.169 to 174	Addition of description to <b>4.3.7 (3) to (6)</b>
p.225	Addition of <b>Figure 4-23 Block Diagram of Type G-7</b>
p.257	Modification of description in <b>Figure 4-55 Block Diagram of Type U-27</b>
p.265	Modification of description in <b>Figure 4-63 Block Diagram of Type U-35</b>
p.266	Addition of <b>Figure 4-64 Block Diagram of Type U-36</b>
p.267	Addition of <b>Figure 4-65 Block Diagram of Type U-37</b>
p.268	Addition of <b>Figure 4-66 Block Diagram of Type U-38</b>
pp.271, 275, 276	Addition of description to <b>Table 4-25 Using Port Pin as Alternate-Function Pin</b>
p.290	Modification of description in <b>5.1 Features</b>
p.293	Addition of description to <b>5.3 Memory Block Function</b>
p.294	Addition of description to <b>Figure 5-1 (a) When using expanded internal RAM</b>
p.295	Addition of <b>Figure 5-1 (b) When not using expanded internal RAM</b>
pp.296, 299, 300	Addition of description to <b>5.3.1 (1) Chip area select control registers 0, 1 (CSC0 and CSC1)</b>
p.303	Modification of description in <b>5.5.2 (1) Bus size configuration register (BSC)</b>
p.312	Addition of description to <b>5.6.1 (2) (a) When using the expansion internal RAM (Other than <math>\mu</math>PD70F3931 (V850E/SJ3-H), 70F3932 (V850E/SJ3-H), 70F3933 (V850E/SJ3-H))</b>
p.313	Addition of <b>5.6.1 (2) (b) When not using the expanded internal RAM</b>
p.317	Modification of description in <b>5.6.4 (1) Address wait control register (AWC)</b>
p.318	Modification of description in <b>5.7 (1) Bus cycle control register (BCC)</b>
p.328	Addition of description to <b>6.1 Overview</b>
pp.330, 331	Addition of description to <b>Table 6-1 Frequency Range of Operating Clocks in Each Clock Mode and Corresponding Source Cocks</b>
p.332	Modification of description in <b>Figure 6-1 Clock Generation Circuit for Clock Mode 1</b>
p.333	Addition of <b>6.2.1 (1) (b) PLLI0 bit = 1 (divided by 2)</b>
p.333	Modification of description in <b>6.2.1 (5) PLL</b>
p.334	Addition of description to <b>6.2.1 (7) Prescaler 1</b>
pp.335, 336	Modification of description in <b>Figure 6-2 Clock Generation Circuit for Clock Mode 2</b>
p.336	Addition of <b>6.2.2 (1) (b) PLLI0 bit = 1 (divided by 2)</b>
p.337	Modification of description in <b>6.2.2 (5) and (6)</b>
p.337	Addition of description to <b>6.2.2 (7) Prescaler 1</b>
pp.338, 339	Modification of description in <b>Figure 6-3 Clock Generation Circuit for Clock Mode 3</b>
p.339	Addition of <b>6.2.3 (1) (b) PLLI0 bit = 1 (divided by 2)</b>
p.340	Modification of description in <b>6.2.3 (5) and (6)</b>
p.340	Addition of description to <b>6.2.3 (7) Prescaler 1</b>

Page	Description
pp.341, 342	Modification of description in <b>Figure 6-4 Clock Generation Circuit for Clock Mode 4</b>
p.343	Modification of description in <b>6.2.4 (5) and (6)</b>
p.343	Addition of description to <b>6.2.4 (7) Prescaler 1</b>
p.353	Addition of description to <b>6.3 (9) SSCG frequency control register 0 (SFC0)</b>
p.717	Addition of description to <b>Table 15-1 Pin Configuration</b>
p.718	Addition of description to <b>15.1.1 (5) UARTA4</b>
p.718	Addition of description to <b>15.1.1 (6) UARTA5</b>
p.746	Modification of description in <b>15.6.10 Receive data noise filter</b>
p.746	Modification of description in <b>Figure 15-12 Timing of RXDAn Signal Judged as Noise</b>
p.759	Modification of description in <b>16.1 Features</b>
p.805	Modification of description in <b>Table 16-5 Baud Rate Generator Setting Data</b>
p.820	Addition of description to <b>Table 17-1 Pin Configuration</b>
p.821	Addition of description to <b>17.1.1 (6) CSIB5</b>
p.878	Addition of <b>Table 18-1 Number of Channels Available for 3-Wire Variable-Length Serial I/O E (CSIE)</b>
pp.878, 879	Addition of description to <b>18.1.1 V850E/SJ3-H (other than <math>\mu</math>PD70F3931, 70F3932, 70F3933)</b>
pp.883, 884	Addition of description to <b>18.3 (2) and (3)</b>
pp.886, 888, 890, 891, 893	Addition of description to <b>18.4 (1) to (5)</b>
p.926	Addition of description to <b>CHAPTER 19 I<sup>2</sup>C BUS</b>
p.927	Addition of description to <b>Table 19-2 Pin Configuration</b>
p.928	Addition of description to <b>19.1.1 (5) I<sup>2</sup>C04 (Other than <math>\mu</math>PD70F3931, 70F3932, and 70F3933)</b>
p.928	Addition of description to <b>19.1.1 (6) I<sup>2</sup>C05 (Other than <math>\mu</math>PD70F3931, 70F3932, and 70F3933)</b>
pp.931, 932, 934 to 948, 952 to 990, 992 to 996, 998 to 1002, 1005 to 1013	Modification of description of <b>Remark</b> in <b>CHAPTER 19 I<sup>2</sup>C BUS</b>
pp.937, 941, 944, 946, 947, 952, 953	Addition of description to <b>19.4 (1) to (5), (7) to (9)</b>
p.1081	Addition of description to <b>20.6 (1) Switching DMA transfer start factor</b>
p.1082	Addition of description to <b>21.1 Overview</b>
p.1260	Addition of description to <b>Table 22-1 DMA Transfer Start Factors</b>
p.1278	Addition of description to <b>CHAPTER 24 INTERRUPT/EXCEPTION PROCESSING FUNCTION</b>
p.1278	Addition of description to <b>24.1 Features</b>
p.1282	Addition of description to <b>Table 24-1 Interrupt Source List</b>
p.1289	Addition of description to <b>24.3 Maskable Interrupts</b>
p.1299	Addition of description to <b>Table 24-2 Interrupt Control Register (xxICn)</b>
pp.1301, 1302	Addition of description to <b>24.3.5 Interrupt mask registers 0 to 6, 7L (IMR0 to IMR6, IMR7L)</b>
p.1335	Addition of description to <b>Table 26-3 Operating Status in HALT Mode</b>
p.1338	Addition of description to <b>Table 26-5 Operating Status in IDLE1 Mode</b>
p.1341	Addition of description to <b>Table 26-7 Operating Status in IDLE2 Mode</b>
p.1345	Addition of description to <b>Table 26-9 Operating Status in STOP Mode</b>

Page	Description
pp.1348, 1349	Addition of description to <b>Table 26-10 Operating Status in Subclock Operation Mode</b>
pp.1352, 1353	Addition of description to <b>Table 26-12 Operating Status in Sub-IDLE Mode</b>
p.1358	Addition of description to <b>27.1 (2) Emergency operation mode</b>
pp.1385, 1386	Addition of description to <b>31.2 (1) Correction address registers 0 to 7 (CORAD0 to CORAD7)</b>
p.1391	Addition of description to <b>(1) V850E/SJ3-H in CHAPTER 32 FLASH MEMORY</b>
p.1391	Addition of description to <b>32.1 Features</b>
p.1392	Addition of <b>Figure 32-1 (a) 512 KB/768 KB/1024 KB</b>
pp.1398 to 1401	Deletion of description to <b>32.4.2 Communication mode</b>
p.1421	Addition of description to <b>CHAPTER 33 OPTION BYTE FUNCTION</b>
p.1423	Modification of description in <b>33.2 Option Byte (0000007BH)</b>
p.1425	Addition of description to <b>CHAPTER 34 ON-CHIP DEBUG FUNCTION</b>
p.1429	Addition of <b>34.1.3 Maskable functions</b>
p.1433	Addition of <b>34.2 Debugging Without Using DCU</b>
p.1454	Addition of description to <b>35.4.3 PLL characteristics</b>
p.1454	Addition of description to <b>35.4.4 SSCG characteristics</b>
p.1458	Modification of description in <b>35.6.2 Supply current</b>
p.1477	Modification of description in <b>35.9 (6) UARTB timing</b>
p.1479	Modification of description in <b>35.9 (8) CSIE timing (other than <math>\mu</math>PD70F3931 (V850E/SJ3-H), 70F3932 (V850E/SJ3-H), and 70F3933 (V850E/SJ3-H))</b>
pp.1480, 1481	Modification of description in <b>35.9 (9) I<sup>2</sup>C bus mode</b>
p.1487	Modification of description in <b>35.10 (3) Programming characteristics</b>
p.1490	Addition of description to <b>Table 37-1 Surface Mounting Type Soldering Condition</b>
p.1496	Addition of <b>Figure A-1 (4) When using MINICUBE2 QB-MINI2</b>
pp.1498 to 1500	Addition of description to <b>A.4.1 When using IECUBE QB-V850ESX3H</b>
p.1503	Addition of <b>A.4.4 When using MINICUBE2 QB-MINI2</b>
p.1506	Modification of description in <b>A.7 Flash Memory Writing Tools</b>
p.1596	Addition of <b>E.2 Revision History of Previous Editions</b>

<R> E.2 Revision History of Previous Editions

A history of the revisions up to this edition is shown below. “Applied to:” indicates the chapters to which the revision was applied.

(1/2)

Edition	Description	Applied to:
2nd	<ul style="list-style-type: none"> <li>• Change of under development state of the following products → Development completed  <math>\mu</math>PD70F3474GJA-GAE-G, 70F3475GJA-GAE-G, 70F3476GJA-GAE-G, 70F3477GJA-GAE-G, 70F3478GJA-GAE-G, 70F3479GJA-GAE-G, 70F3480GMA-GAR-G, 70F3481GMA-GAR-G, 70F3482GMA-GAR-G</li> <li>• Addition of the following products  <math>\mu</math>PD70F3486GMA-GAR-G, 70F3487GMA-GAR-G, 70F3488GMA-GAR-G, 70F3925GMA-GAR-G, 70F3926GMA-GAR-G, 70F3927GMA-GAR-G</li> <li>• Change of the following product names            FA-144GJ-GAE-AX → FA-144GJ-GAE-B            FA-176GM-GAR-AX → FA-176GM-GAR-B</li> </ul>	Throughout
	Addition of description to <b>Table 1-1 V850E/SJ3-H and V850E/SK3-H Products</b>	CHAPTER 1 INTRODUCTION
	Addition of description of <b>Memory space</b> to <b>1.2 Features</b>	
	Addition of description to <b>1.4.2 V850E/SK3-H</b>	
	Addition of description to <b>1.5.1 V850E/SJ3-H</b>	
	Addition of description to <b>1.5.2 V850E/SK3-H</b>	
	Addition of description to <b>1.6.1 (1) V850E/SJ3-H</b>	
	Addition of description to <b>1.6.1 (2) V850E/SK3-H</b>	
	Addition of description to <b>1.6.2 (3) ROM</b>	
	Addition of description to <b>1.6.2 (5) Expanded internal RAM</b>	
	Addition of <b>3.4.4 (1) (a) Internal ROM (1024 KB)</b>	CHAPTER 3 CPU FUNCTION
	Addition of description to <b>3.4.4 (1) (b) Internal ROM (1280 KB)</b>	
	Addition of <b>3.4.4 (6) (a) Expanded internal RAM (16 KB)</b>	
	Addition of description to <b>3.4.4 (6) (b) Expanded internal RAM (32 KB)</b>	
	Addition of description to <b>Table 3-3 Product Name Setting Examples</b>	
	Addition of description to <b>3.4.6 Peripheral I/O registers</b>	
	Addition of description to <b>Figure 5-1 Data Memory Map: Physical Address</b>	CHAPTER 5 BUS CONTROL FUNCTION
	Addition of description to <b>5.3.1 (1) Chip area select control register 0 (CSC0)</b>	
	Addition of description to <b>6.2 Clock Mode</b>	
	Addition of description to <b>Table 6-1 Frequency Range of Operating Clocks in Each Clock Mode and Corresponding Source Coeks</b>	CHAPTER 6 CLOCK GENERATION FUNCTION
	Modification of <b>Figure 6-3 Clock Generation Circuit for Clock Mode 3</b>	
	Addition of description to <b>6.3 (9) SSCG frequency control register 0 (SFC0)</b>	
	Modification of description in <b>9.4.2 (1) Maximum time before counting start</b>	
	Modification of description in <b>9.4.2 (1) Maximum time before counting start</b>	CHAPTER 9 16-BIT INTERVAL TIMER M (TMM)
	Addition of description to <b>15.4 (4) UARTAn option control register 0 (UAnOPT0)</b>	
	Addition of description to <b>15.4 (4) UARTAn option control register 0 (UAnOPT0)</b>	CHAPTER 15 ASYNCHRONOUS SERIAL INTERFACE A (UARTA)

Edition	Description	
2nd	Modification of description in <b>Table 19-6 Extension Code Bit Definitions</b>	CHAPTER 19 I <sup>2</sup> C BUS
	Modification of description in <b>20.3 (8) IEBus slave address register (SAR)</b>	CHAPTER 20 IEBus CONTROLLER
	Addition of description to <b>21.1 Overview</b>	CHAPTER 21 CAN CONTROLLER
	Addition of description to <b>21.6 (1) CANn global control register (CnGMCTRL)</b>	
	Addition of description to <b>21.6 (23) CANn message control register m (CnMCTRLm)</b>	
	Modification of description in <b>Figure 21-57 Forced Shutdown Process</b>	
	Addition of description to <b>22.13 (7) Bus arbitration for CPU</b>	CHAPTER 22 DMA FUNCTION (DMA CONTROLLER)
	Modification of description in <b>27.1 (2) Emergency operation mode</b>	CHAPTER 27 RESET FUNCTIONS
	Modification of description in <b>Table 27-1 Hardware Status on RESET Pin Input</b>	
	Modification of description in <b>Table 27-2 Hardware Status During Watchdog Timer 2 Reset Operation</b>	
	Modification of description in <b>Table 27-3 Hardware Status During Reset Operation by Low-Voltage Detector</b>	
	Addition of description to <b>31.2 (1) Correction address registers 0 to 7 (CORAD0 to CORAD7)</b>	CHAPTER 31 ROM CORRECTION FUNCTION
	Addition of description to <b>CHAPTER 32 FLASH MEMORY (2) V850E/SK3-H</b>	CHAPTER 32 FLASH MEMORY
	Addition of description to <b>32.1 Features</b>	
	Addition of <b>Figure 32-1 Flash Memory Mapping</b>	
	Modification of description in <b>Table 32-6 Wiring of V850E/SJ3-H, V850E/SK3-H Flash Writing Adapters (FA-144GJ-GAE-B, FA-176GM-GAR-B)</b>	
	Modification of description in <b>Figure 32-6 Example of Wiring of V850E/SJ3-H Flash Writing Adapter (FA-144GJ-GAE-B) (in CSIB0 + HS Mode)</b>	
	Modification of description in <b>Figure 32-7 Example of Wiring of V850E/SK3-H Flash Writing Adapter (FA-176GM-GAR-B) (in CSIB0 + HS Mode)</b>	
	Addition of <b>CHAPTER 35 ELECTRICAL SPECIFICATIONS</b>	CHAPTER 35 ELECTRICAL SPECIFICATIONS
	Addition of <b>CHAPTER 37 RECOMMENDED SOLDERING CONDITIONS</b>	CHAPTER 37 RECOMMENDED SOLDERING CONDITIONS
Modification of description in <b>A.7 Flash Memory Writing Tools</b>	APPENDIX A DEVELOPMENT TOOLS	
Addition of <b>APPENDIX D LIST OF CAUTIONS</b>	APPENDIX D LIST OF CAUTIONS	
Addition of <b>APPENDIX E REVISION HISTORY</b>	APPENDIX E REVISION HISTORY	

Published by: NEC Electronics Corporation (<http://www.necel.com/>)

Contact: <http://www.necel.com/support/>